



US005112304A

United States Patent [19]

[11] Patent Number: **5,112,304**

Barlow et al.

[45] Date of Patent: **May 12, 1992**

[54] **BALLOON CATHETER**

4,782,834 11/1988 Maguire et al. 604/280

[75] Inventors: **Edward A. Barlow**, Bloomington;
Gregory G. Brucker, Minneapolis,
both of Minn.

Primary Examiner—C. Fred Rosenbaum
Assistant Examiner—William Lewis
Attorney, Agent, or Firm—Hugh D. Jaeger

[73] Assignee: **Angeion Corporation**, Plymouth,
Minn.

[57] **ABSTRACT**

[21] Appl. No.: **324,913**

A balloon consisting of braided fibers encapsulated between two plastic elastomeric materials affixes to a distal end of a catheter. The braided fibers provide reinforcement to contain pressure and determine the maximum diameter of the balloon on expansion. The elastomeric material provides for fluid containment and collapsing of the balloon after pressurization. An embedded spring in an elastomeric material internal to the catheter provides memory to assist in collapsing the balloon after pressurization. The embedded spring extends from the distal end of the catheter towards the proximal end of the catheter along a substantial length of the catheter. The catheter with the balloon are in a multilumen configuration or in a coaxial configuration. A guidewire passage extends through the elastomeric material with the embedded spring.

[22] Filed: **Mar. 17, 1989**

[51] Int. Cl.⁵ **A61M 25/10**

[52] U.S. Cl. **604/96; 606/194**

[58] Field of Search 128/344, 348.1, 656-658;
604/96-103, 280, 282; 606/191, 192, 194

[56] **References Cited**

U.S. PATENT DOCUMENTS

4,289,128	9/1981	Rüsch	128/204.25
4,597,755	7/1986	Samson et al.	604/280
4,637,396	1/1987	Cook	128/344
4,650,466	3/1987	Luther	604/266
4,650,467	3/1987	Bonello et al.	128/348.1
4,702,252	10/1987	Brooks et al.	128/344
4,706,670	11/1987	Anderson et al.	128/344

17 Claims, 10 Drawing Sheets

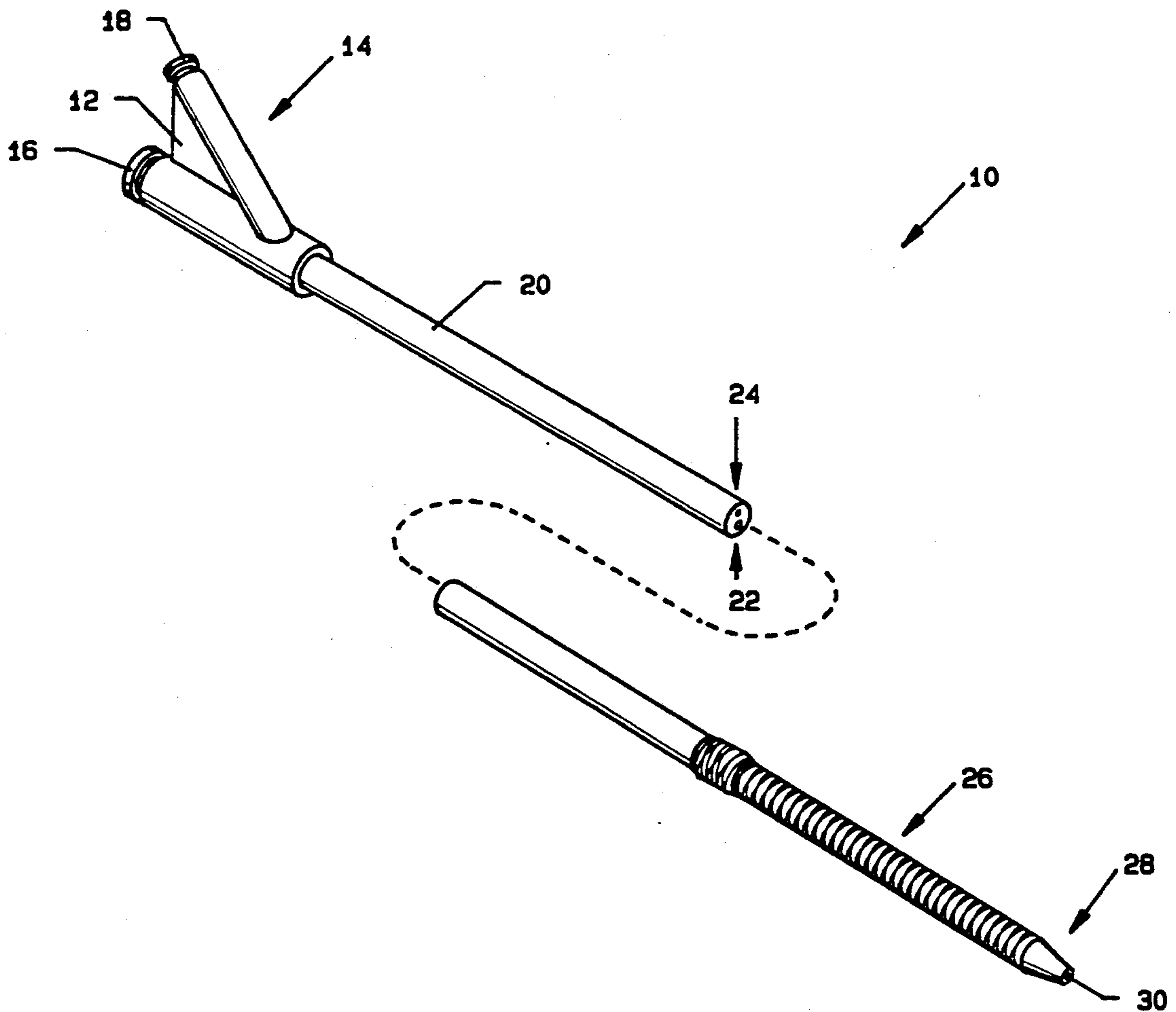

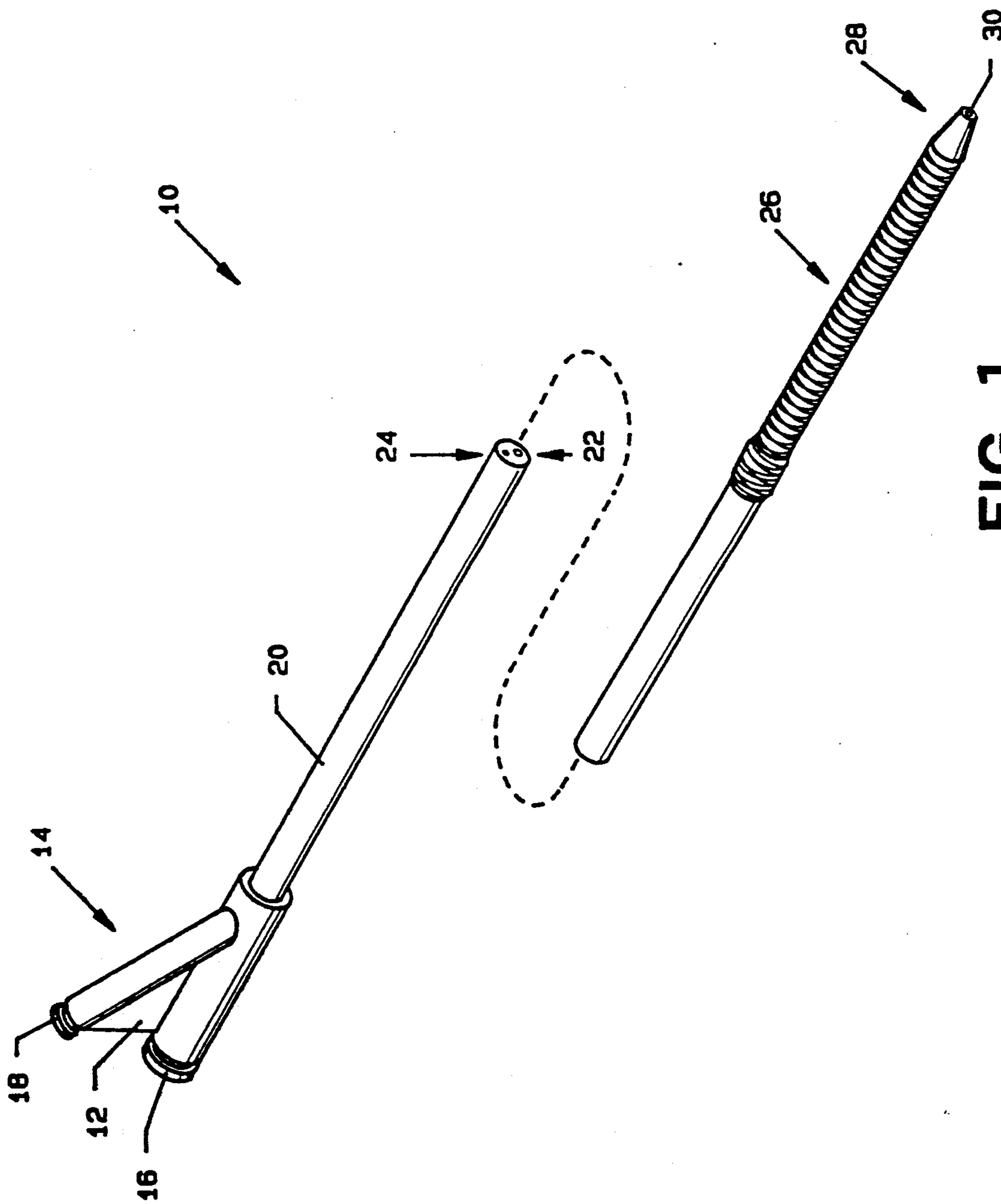

FIG. 1

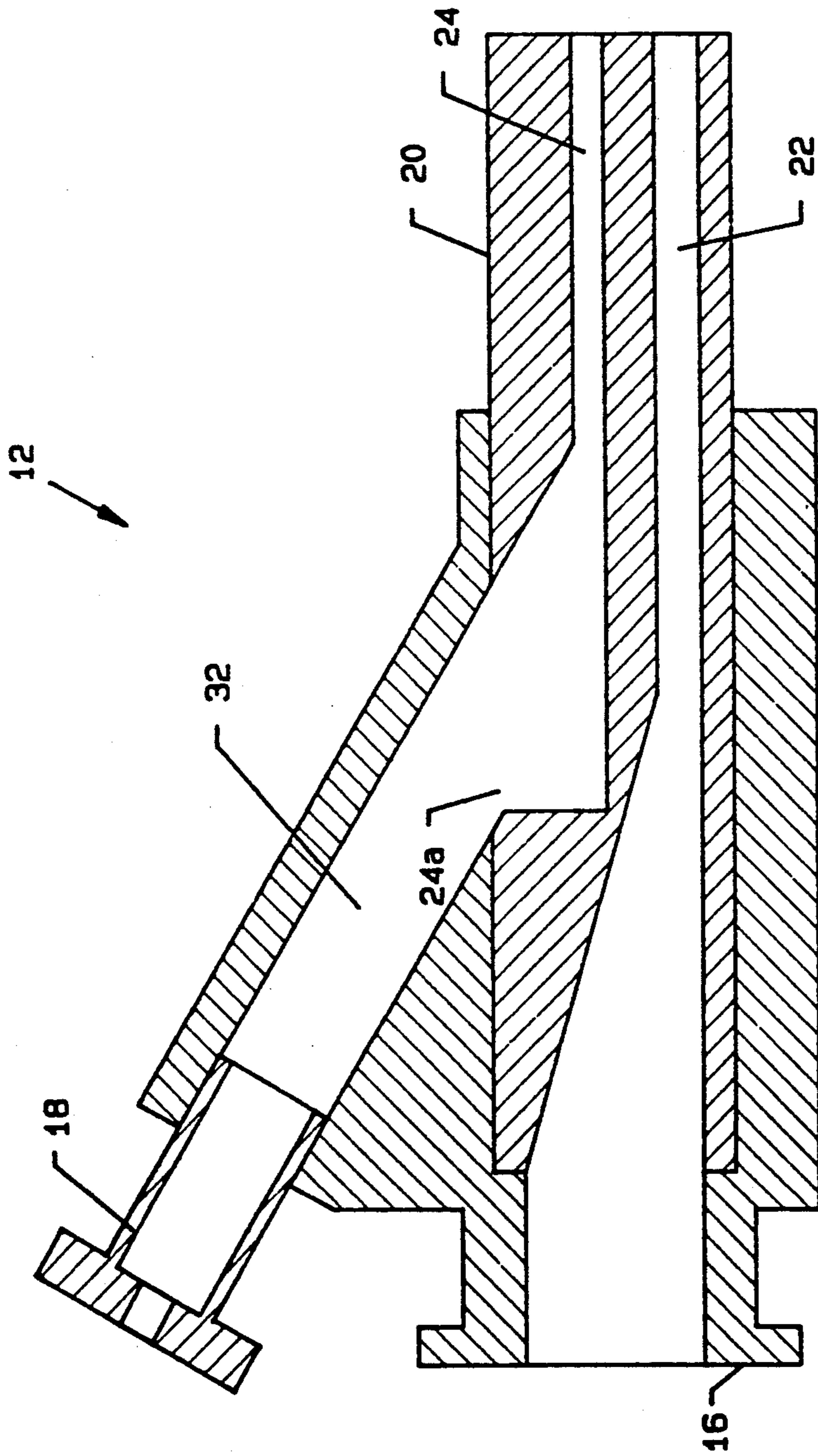

FIG. 2

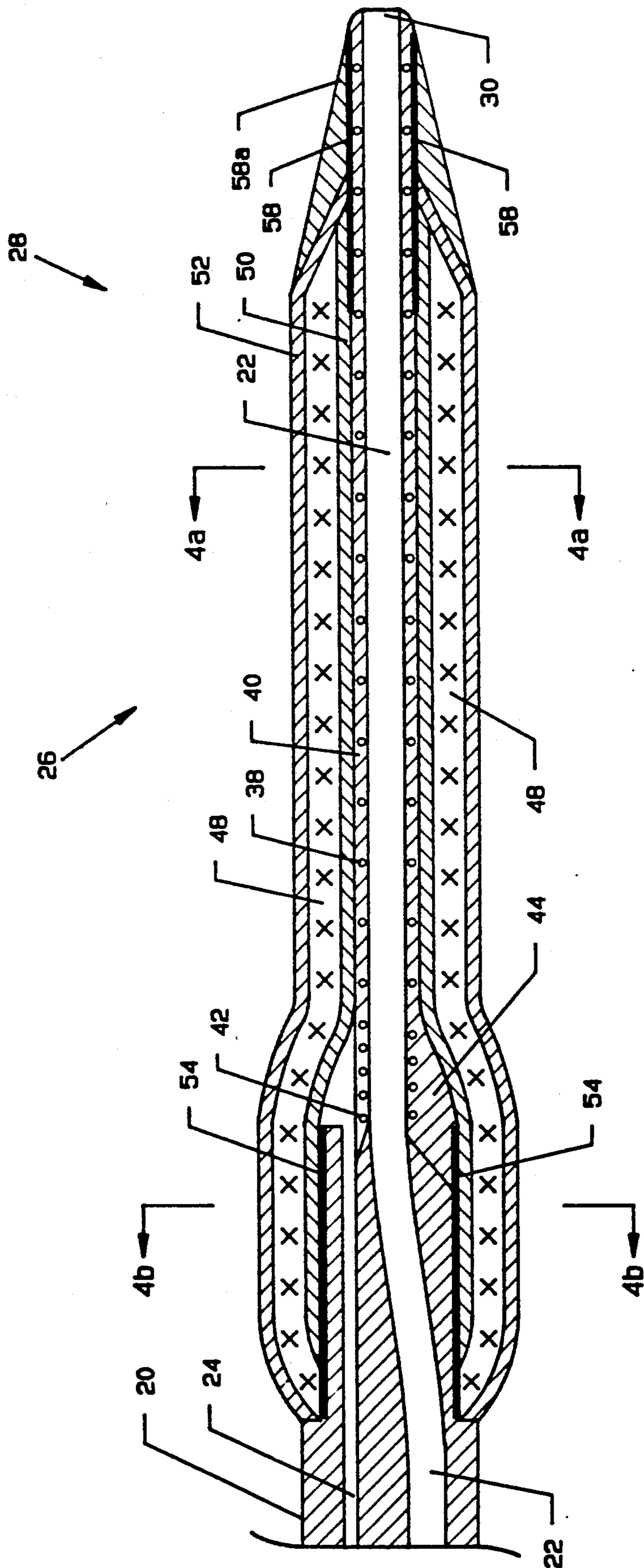

FIG. 3

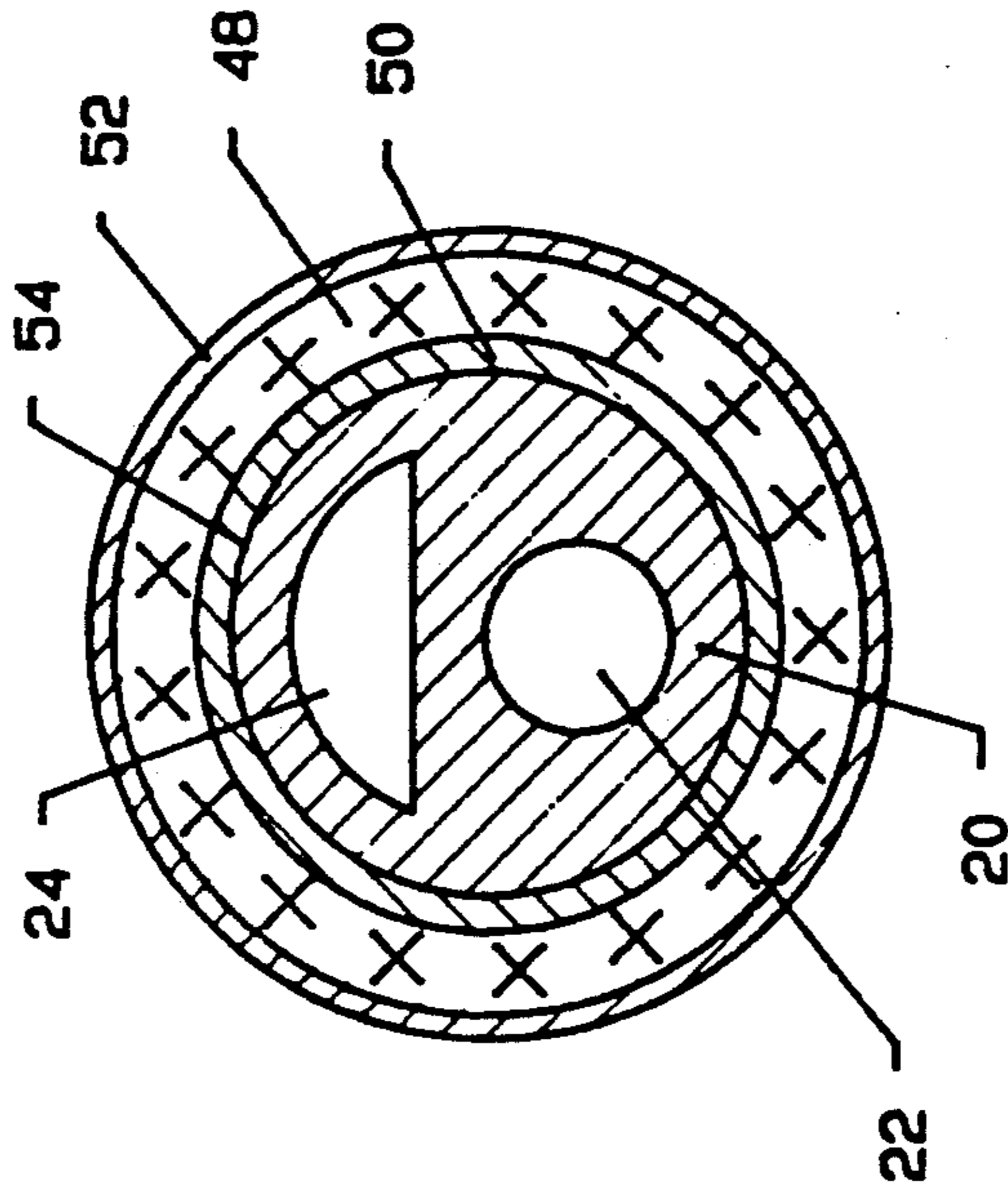

FIG. 4a

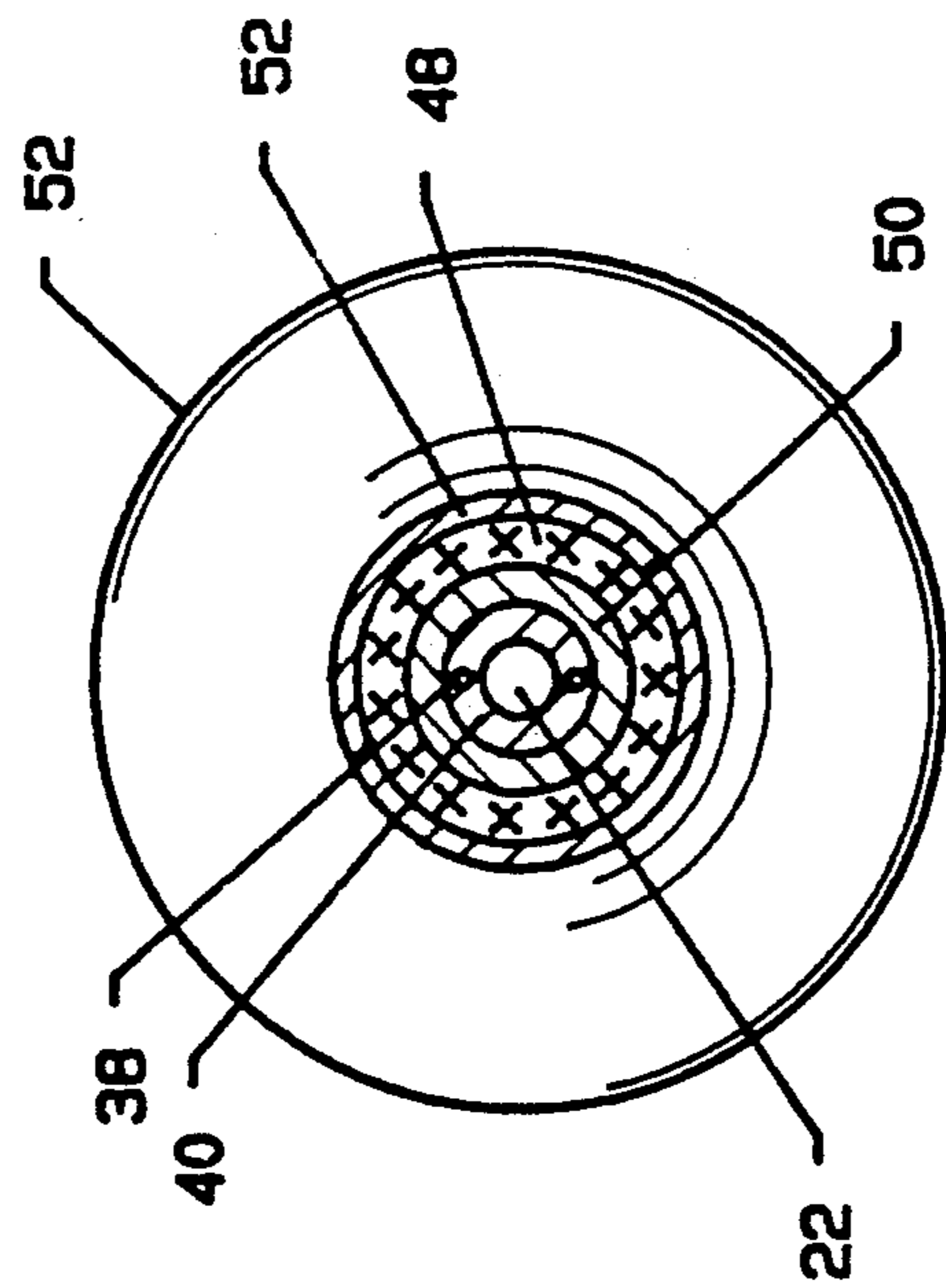

FIG. 4b

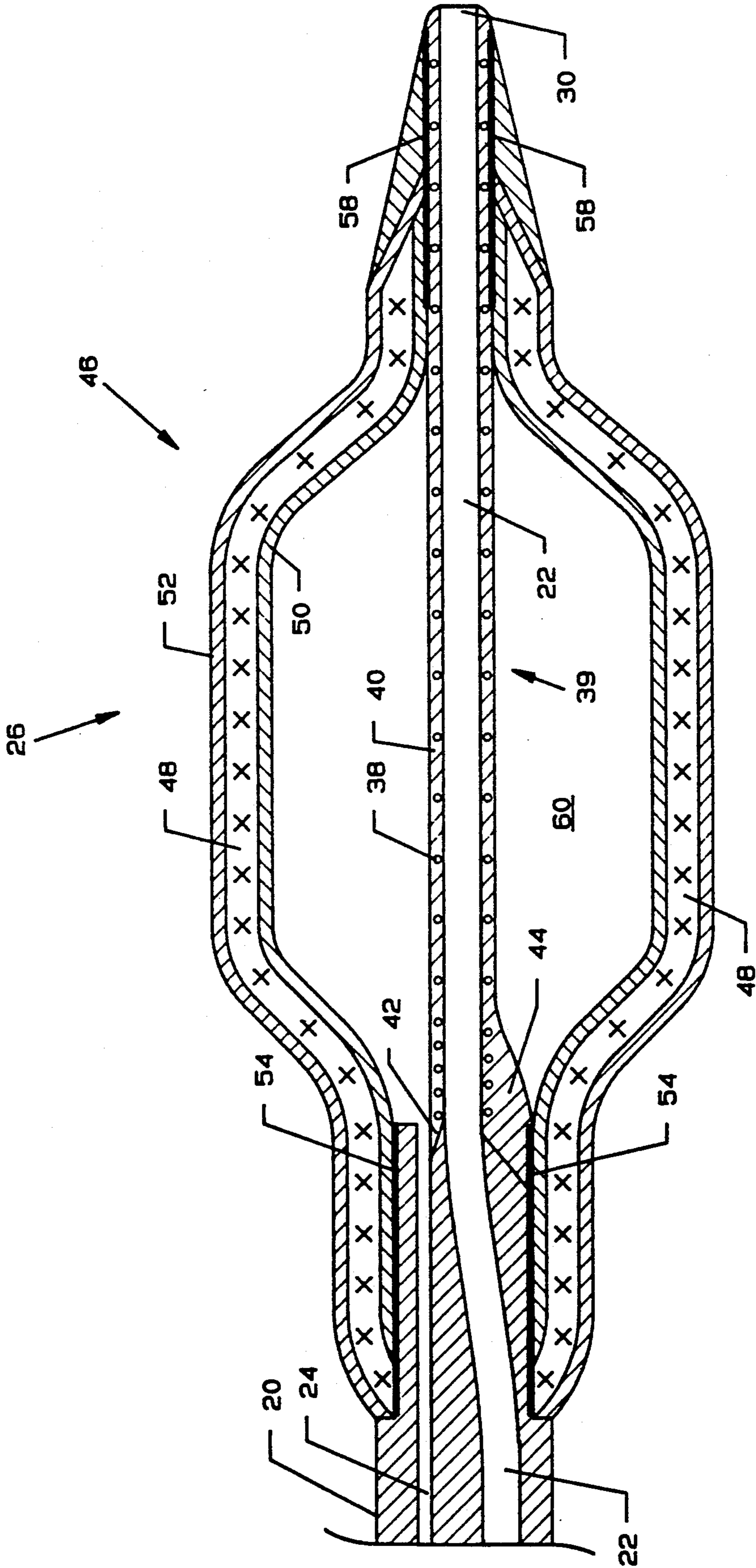

FIG. 5

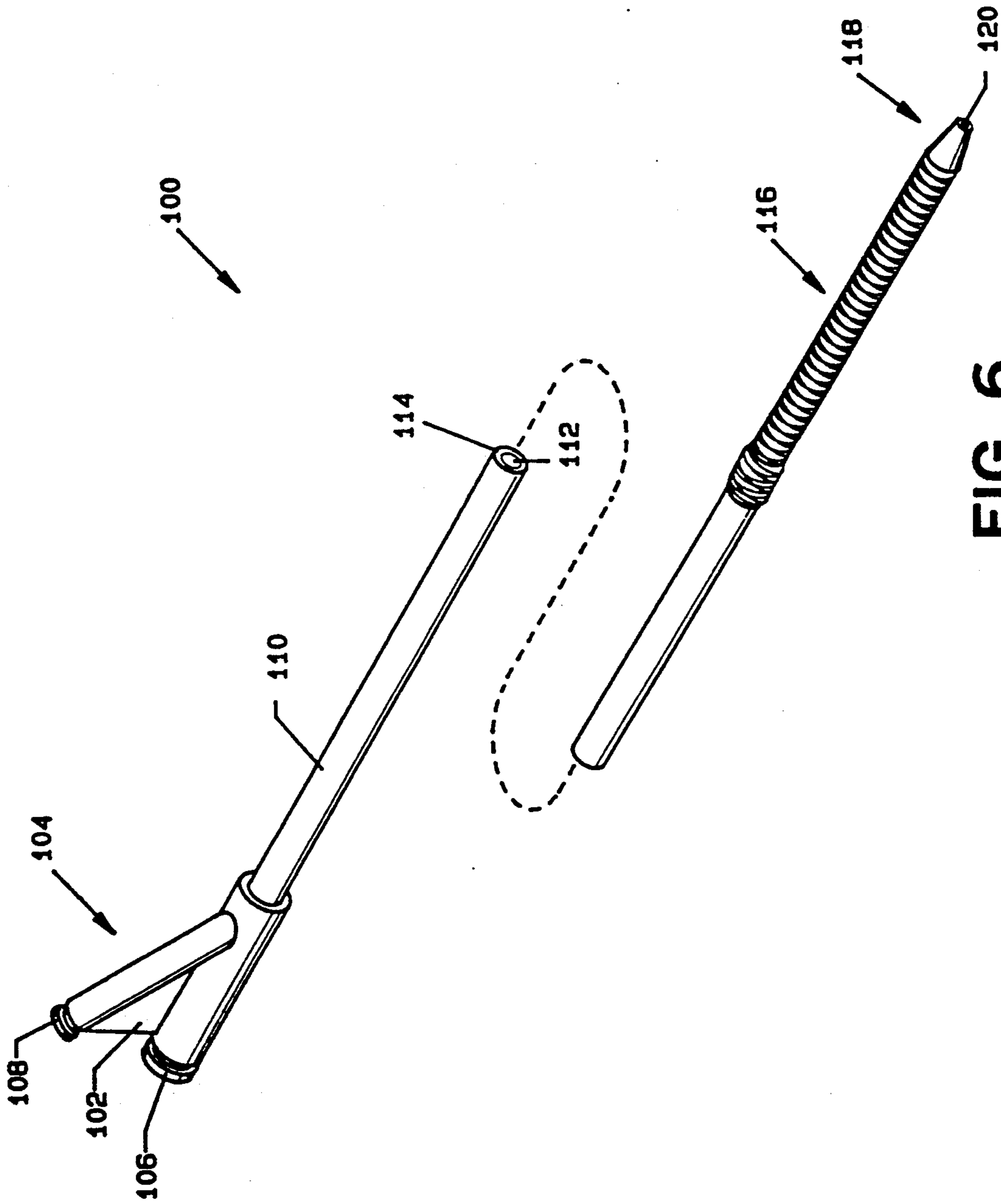

FIG. 6

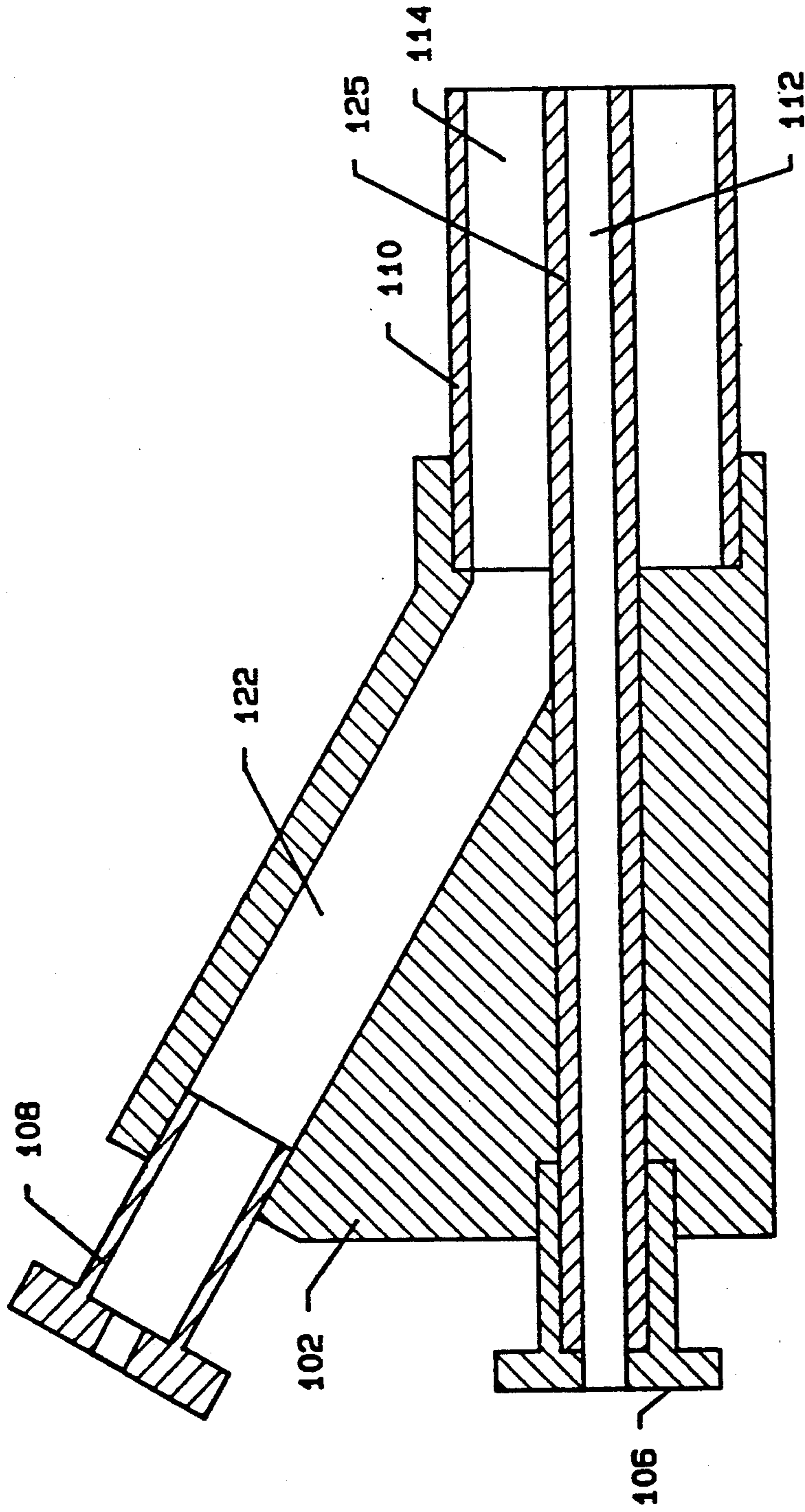

FIG. 7

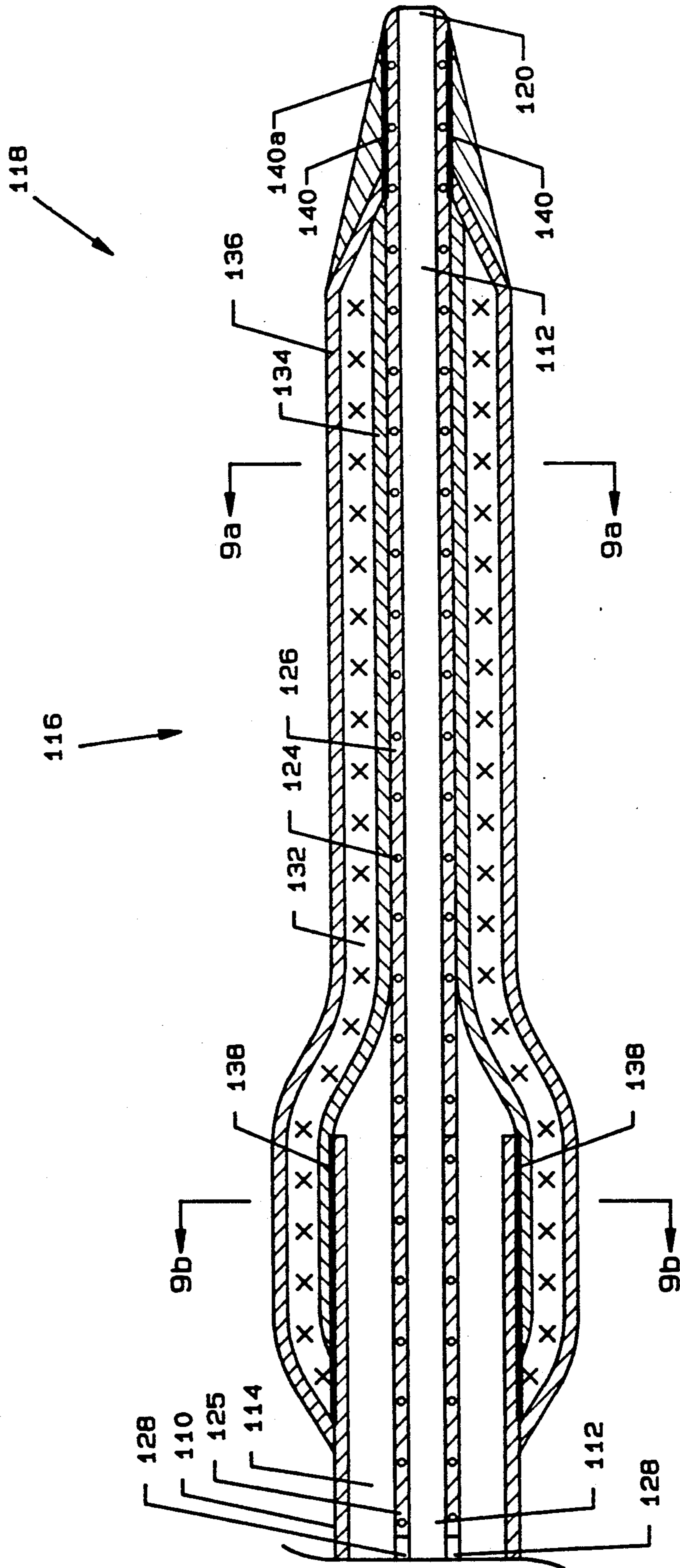

FIG. 8

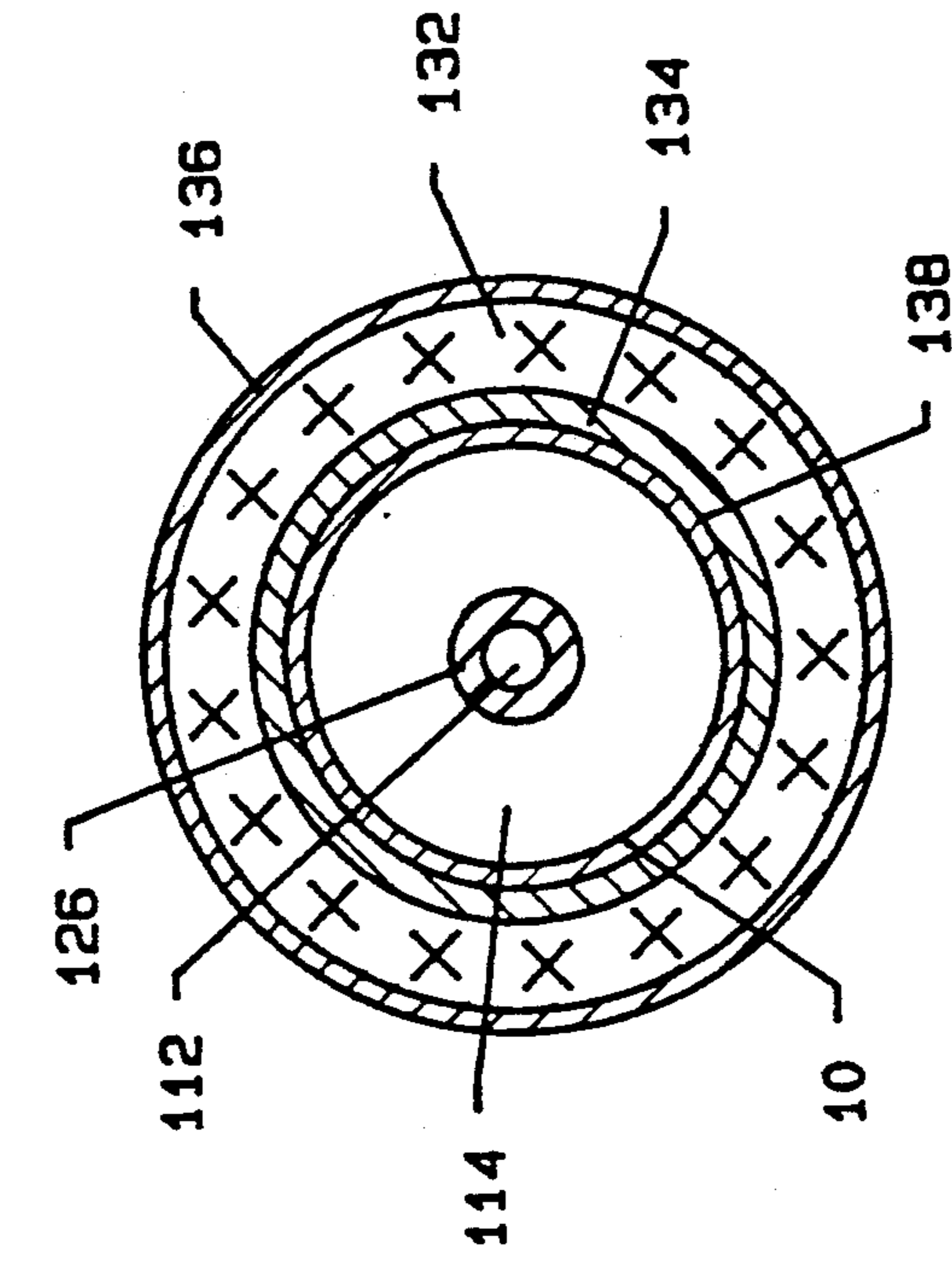

FIG. 9a

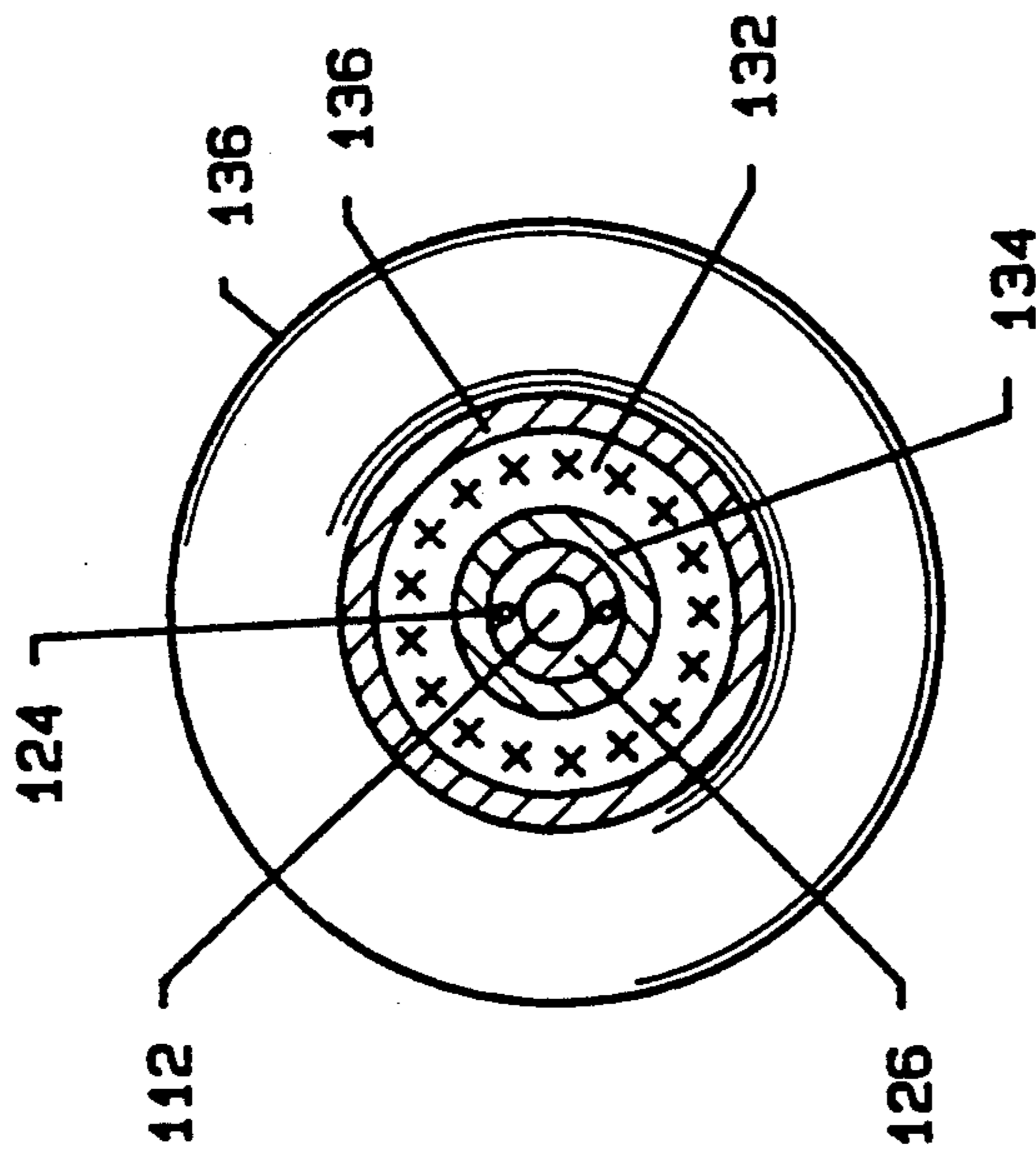

FIG. 9b

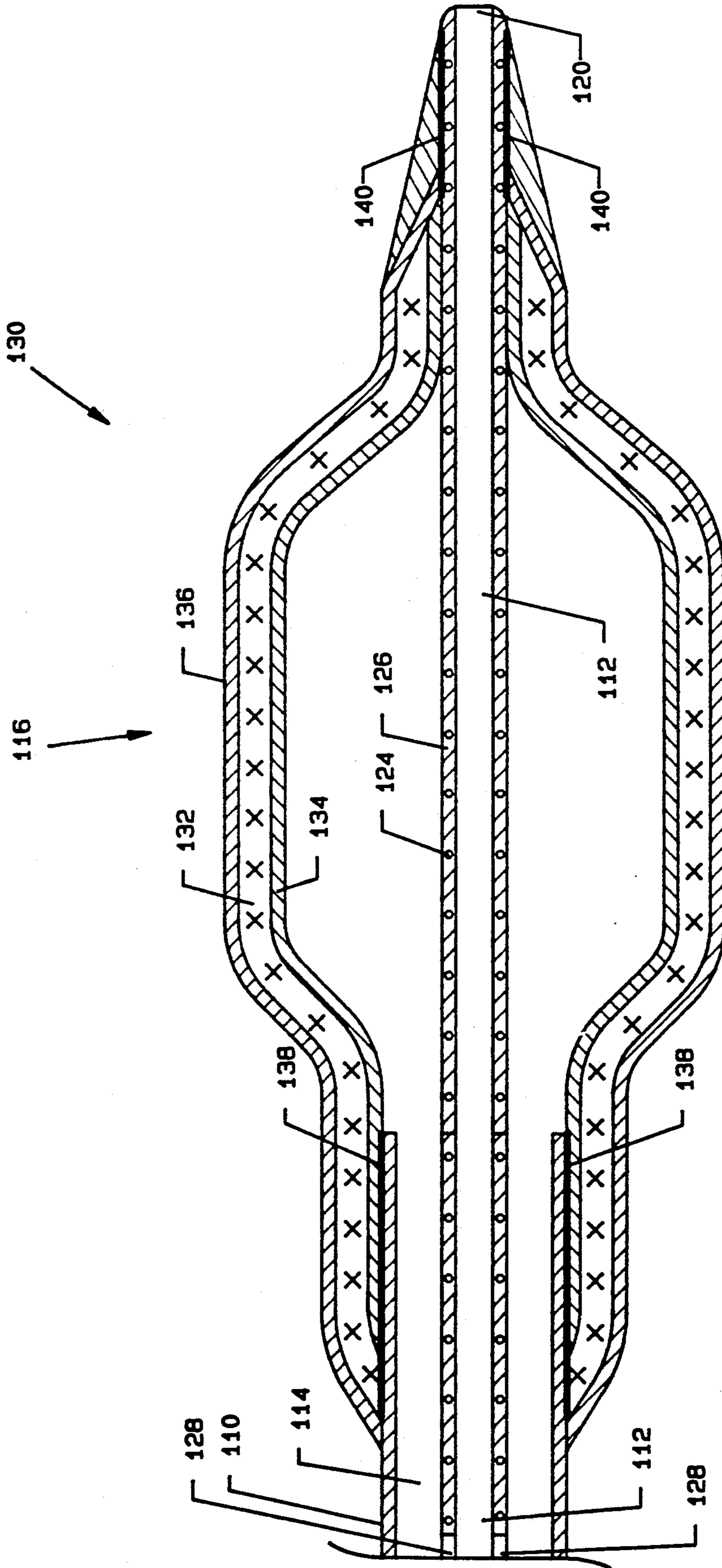

FIG. 10

BALLOON CATHETER**BACKGROUND OF THE INVENTION****1. Field of the Invention**

The present invention pertains to a surgical catheter, and more particularly, a balloon catheter for enlargement of restrictions in blood vessels, arteries or other human tissue.

2. Description of the Prior Art

Prior art balloon catheters have utilized numerous types of structures to expand outwardly to enlarge a restriction such as in a blood vessel, an artery or human tissue, such as the prostate. One problem in the past with these structures which enlarged on inflation was that the structure did not always return to its original diameter or initial circular configuration.

U.S. Pat. No. 4,456,000 to Seheldahl uses a thin rigid material affixed to the distal end of a catheter to form Particularly in the use of non-distensible balloons, the initial profiles achieved by wrapping the balloon are much larger than the outer diameter of the catheter shaft and after inflation in the body, the resulting collapsed profile may appear in cross section as a plate extending outward from the center of the catheter. This necessitates use of a larger device to introduce the balloon catheter and presents complication on removal of the device from the body and may potentially damage tissue.

U.S. Pat. No. 4,637,396 to Cook uses a knitted balloon in which the knitting changes shape to accommodate balloon expansion. This allows for higher pressures to be achieved in larger diameter balloons, but does not necessarily deal with initial or collapsed profiles.

U.S. Pat. No. 4,702,252 to Brooks uses a braided balloon which changes in length as it expands and is accomplished by a spring at the proximal hub end of the catheter. This design requires relative motion between various members of the catheter which may be difficult in long length and tortuous passageways.

U.S. Pat. No. 4,762,130 to Fogarty uses an embedded spring to lower the profiles of the balloon. This design also requires relative motion along its length and does not enhance the pressure changing capability of the elastomeric materials.

The present invention overcomes the disadvantages of the prior art by providing a balloon catheter with braided fibers encapsulated between elastomeric materials and an embedded spring to provide a low balloon profile after pressurization and depressurization.

SUMMARY OF THE INVENTION

The general purpose of the present invention is to provide a balloon catheter which has a low profile in a deflated state after pressurization to a maximum diameter, and has no components which move relative to one another.

According to one embodiment of the present invention, there is provided a balloon catheter with a hub at a proximal end including a guidewire entry port, an inflation/deflation port and a tube connected to the hub. A guidewire passage and an inflation/deflation passage extend along the length of the tube. An embedded spring in an elastomeric material or like material connects to the distal end of the tube. A balloon, including braided fibers encapsulated between an outer elastomeric material and inner elastomeric material, connects between the end of the tube and the distal end of the

embedded spring member. The catheter can assume either a multilumen configuration or a coaxial configuration.

Significant aspects and features of the present invention include a low profile balloon before and after pressurization to its maximum diameter. The differential between the balloon structure and the inner member of the catheter is minimal, even after pressurization and subsequent depressurization because of the combined action of the internal spring and the elastomeric material of the balloon. The pliability of the elastomeric material and the spring also provide enhanced steering of the catheter during placement due to its extreme flexibility and soft tip.

Other significant aspects and features of the present invention is the ability to achieve higher balloon pressures, especially in larger sized balloons used in larger vessels, arteries or tissues.

Further significant aspects and features of the present invention include a braided fiber member which expands to a fixed diameter on inflation with enhanced pressure conveying capability. The braided fibers assist the balloon to collapse to approximately the same profile after pressurization. Additionally, there is enhanced cyclic durability because of the elastomeric materials.

In addition, the use of fibers and elastomeric materials in the balloon construction provides for a softer distal tip to the catheter, enhancing steerability and reducing trauma. In addition, the elastomeric material provides a construction which enhances its ability to withstand repeated cycles of pressurization and depressurization.

In addition, the braid can be made of a radiopaque material affecting the need for specific bands for locating the balloon in the body under fluoroscopy.

Lastly, the embedded spring also provides structural integrity against collapse of the inner member of the catheter during pressurization of the balloon. This enhanced ability allows for movement of the guidewire while the balloon is pressurized.

Having thus described embodiments of the present invention, it is a principal object hereof to provide a balloon catheter with a balloon using braided fibers or like materials disposed between an inner and an outer elastomeric layer.

One object of the present invention is to provide a multilumen balloon configuration or a coaxial balloon configuration.

Another object of the present invention is to provide a balloon catheter which includes internal structure which functions to deflate and collapse the balloon after pressurization to its maximum diameter. The balloon with braided fibers between the elastomeric material returns to its normal position, and a spring embedded in an elastomeric material of the distal end of the catheter further functions to collapse and return the balloon to a normal, deflated position after pressurization. A material with a like function can also be utilized in place of the spring.

BRIEF DESCRIPTION OF THE DRAWINGS

Other objects of the present invention and many of the attendant advantages of the present invention will be readily appreciated as the same becomes better understood by reference to the following detailed description when considered in connection with the accompanying drawings, in which like reference numerals design-

nate like parts throughout the figures thereof and wherein:

FIG. 1 illustrates a perspective view of a multilumen balloon catheter, the present invention;

FIG. 2 illustrates a cross-sectional view of the hub of the multilumen configuration;

FIG. 3 illustrates a cross-sectional view of the distal end of the multilumen configuration;

FIG. 4A illustrates a cross-sectional view taken along line 4a—4a of FIG. 3 of the multilumen configuration;

FIG. 4B illustrates a cross-sectional view taken along line 4b—4b of FIG. 3 of the multilumen configuration;

FIG. 5 illustrates the expanded balloon of the multilumen configuration;

FIG. 6 illustrates a perspective view of a coaxial balloon catheter, an alternative embodiment of the present invention of the coaxial configuration;

FIG. 7 illustrates a cross-sectional view of the hub of the coaxial configuration;

FIG. 8 illustrates a cross-sectional view of the distal end of the coaxial configuration;

FIG. 9A illustrates a cross-sectional view taken along line 9a—9a of FIG. 8 of the coaxial configuration;

FIG. 9B illustrates a cross-sectional view taken along line 9b—9b of FIG. 8 of the coaxial configuration; and,

FIG. 10 illustrates the expanded balloon of the coaxial configuration.

DESCRIPTION OF THE PREFERRED EMBODIMENTS

FIG. 1 illustrates a perspective view of a multilumen balloon catheter 10, the present invention, including a hub 12 at a proximal end 14 with guidewire entry port 16 and an inflation/deflation port 18. This particular multilumen configuration is bilumen. A catheter tube 20 connects to the hub 12, and includes a guidewire passage 22 and an inflation/deflation passage 24. A balloon structure 26, as later described in detail, secures about the distal end 28. A guidewire exit 30 is at the distal end 28 of the balloon structure 26.

FIG. 2 illustrates a cross-sectional view of the hub 12 where all numerals correspond to those elements previously described. The figure illustrates the hub 12 being a molded thermoplastic member engaged about the catheter tube 20, and fused or adhesively secured thereto. The hub 12 includes a hub chamber 32, an inflation/deflation port 18, and a guidewire entry port 16. The proximal end of the catheter tube 20 secures into one end of the guidewire entry port 16. The hub 12, the catheter tube 20, the guidewire entry port 16 and the inflation/deflation port 18 are assembled by known processes. The guidewire passage 22, internal to the catheter tube 20, connects between the guidewire entry port 16 and the balloon structure 26 of FIG. 3. The inflation/deflation passage 24 connects the balloon structure 26 to the inflation/deflation port 18 through an angled passageway 24a and the hub chamber 32.

FIG. 3 illustrates a cross-sectional view of the distal end 28 of the balloon catheter 10. An embedded spring 38 is embedded or fused into elastomeric material 40 which connects to the catheter tube 20 at point 44, such as by heat fusion or adhesively. The spring can be tensioned to a predetermined degree prior to being embedded in the elastomeric material providing a memory for the embedded spring 38 in the elastomeric material. A balloon structure 26, which is coaxial, includes a braided fiber 48 between an inner elastomeric material 50 and outer elastomeric material 52, which is secured

about point 54 of the catheter tube 20 and about point 58 of the embedded spring 38 and elastomeric material 40 containing the guidewire passage 22, such as by heat fusion or adhesively. The molded tip 58a provides flexibility and softness of the catheter.

FIG. 4A illustrates a cross-sectional view taken along line 4a—4a of FIG. 3 where all numerals correspond to those elements previously described.

FIG. 4B illustrates a cross-sectional view taken along line 4b—4b of FIG. 3 where all numerals correspond to those elements previously described.

FIG. 5 illustrates the balloon catheter 10, and particularly, the balloon structure 26 in an inflated balloon position 46. All numerals correspond to those elements previously described. The embedded spring 38 is compressed longitudinally and the braided fiber 48 has been expanded outwardly so as to enlarge along a substantial portion of its length centered at approximately the midpoint of the longitudinal length of the braided fibers. The outward expansion of the braided fibers 48 effectively shortens the length of the balloon 26 in a direction towards the proximal end 14 causing the embedded spring 38 to compress in a like direction. The braided fibers 48 provide for expansion to a predetermined diameter for the balloon, and form a cavity 60 about the inner surfaces of the balloon structure 26 and the member with the embedded spring 38. After deflation of the inflated balloon position 46 and placing a vacuum on the inflated balloon position 46 through the inflation/deflation port 18, the elastomeric materials 50 and 52 about the braided fibers 48 in combination, provide for collapsing of the balloon, as well as the embedded spring 38 returning to a normal resting position. Likewise, the memory of the elastomeric material materials 50 and 52 and the embedded spring 38 secondarily assist the balloon structure in returning to a predetermined collapsed condition. Materials of known elasticity can be selected such that the braided fibers or the spring may not be required. The elastomeric materials can also be selected to have different degrees of elasticity for expansion and subsequent contraction.

MODE OF OPERATION

Referring to FIGS. 1-5, during a typical procedure, a guidewire is placed through a body tube or tissue to be dilated, typically an artery. The balloon catheter 10 is then introduced over the guidewire by placing the distal end 28 of the catheter over the proximal end of a guidewire. The balloon catheter 10 is then moved into a position of restriction by moving the catheter over the guidewire. Once in position, a syringe filled with a radiopaque fluid is attached to the inflation/deflation port 18 and the syringe plunger moved inward to inflate and pressurize the inflated balloon position 46 by passing radiopaque fluid through the inflation/deflation passage 24 and into the cavity 60 to expand the balloon structure 26 outwardly to a desired intermediate expansion point or to a maximum expansion point allowed by the weave structure of the braided fibers 48. After inflation, a vacuum is introduced into the balloon by moving the plunger outward. The balloon then returns to its resting position. The catheter is then removed from the body. The balloon is caused to return to its normal deflated position by the braided fibers seeking to return to a resting position, the elasticity of the materials and the embedded spring 38.

DESCRIPTION OF THE ALTERNATIVE EMBODIMENTS

FIG. 6 illustrates a perspective view of a coaxial balloon catheter 100, an alternative embodiment of the present invention, including a hub 102 at a proximal end 104 with guidewire entry port 106 and an inflation/deflation port 108. A coaxial catheter tube 110 connects to the hub 102, and includes a guidewire passage 112 and an inflation/deflation passage 114. A balloon structure 116, as later described in detail, secures about the distal end 118. A guidewire exit 120 is at the distal end 118 of the tube 110. The principles of the alternative embodiment are like those as described in FIGS. 1-5.

FIG. 7 illustrates a cross-sectional view of the hub 102 where all numerals correspond to those elements previously described. The figure illustrates the hub 102 being a molded member engaged about the tube 110 and fused or adhesively secured thereto. The hub 102 includes a hub chamber 122, an inflation/deflation port 108, and a guidewire entry port 106 secured into the hub 102. The proximal end of the tube 110 secures into one end of the guidewire entry port 106. The hub 102, the tube 110, the guidewire entry port 106 and the inflation/deflation entry port 108 are assembled by known processes. An inner coaxially aligned tube 125 forms the guidewire passage 112 and connects between the guidewire entry port 106 and the balloon structure 116 of FIG. 8. The inflation/deflation passage 114 is formed between the walls of the tube 110 and the elastomeric material 125 in a coaxial fashion. The inflation/deflation passage 114 connects the balloon structure 116 to the inflation/deflation port 108 through the hub chamber 122 as illustrated in FIG. 8.

FIG. 8 illustrates a cross-sectional view of the distal end 118 of the balloon catheter 100. An embedded spring 124 is embedded in elastomeric material 126 which connects to the tube 110 at point 128, such as by heat fusion or adhesive. The embedded spring 124 can be tensioned to a predetermined degree prior to being embedded in the elastomeric material providing a memory for the embedded spring in the elastomeric material. A balloon structure 116 which is coaxial includes an inner braided fiber 132 between an inner elastomeric material 134 and an outer elastomeric material 136, secures about point 138 of the tube 110 and about point 140 of the embedded spring 124 and inner elastomeric material 126 containing the guidewire passage 112 such as by heat fusion or adhesively. The molded tip 140a provides flexibility and softness of the catheter.

FIG. 9A illustrates a cross-sectional view taken along line 9a-9a of FIG. 8 where all numerals correspond to those elements previously described.

FIG. 9B illustrates a cross-sectional view taken along line 9b-9b of FIG. 8 where all numerals correspond to those elements previously described.

FIG. 10 illustrates a balloon catheter 100, and particularly the balloon 130 in an inflated mode position. All numerals correspond to those elements previously described. The operation is similar to that as described for FIGS. 1-5.

Various modifications can be made to the present invention without departing from the apparent scope hereof.

I claim:

1. Balloon catheter comprising:

a. catheter tube including a guidewire passage and an inflation/deflation passage;

b. a hub including a guidewire entry port and an inflation/deflation port on a proximal end of said catheter tube;

c. a tube of elastomeric material of a short length affixed to the distal end of said catheter tube; and,

d. a balloon fixedly secured to the outer surface of said distal end of said catheter tube at one end of said balloon and fixedly secured to the outer surface of a distal end of said tube at the other end of said balloon, wherein said balloon includes a braided fiber layer located between an inner elastomeric material layer with memory and an outer elastomeric material layer with memory and wherein said braided fiber layer is fixedly secured adjacent said distal end of said catheter tube and fixedly secured adjacent said distal end of said tube.

2. Balloon catheter of claim 1 wherein said catheter tube is bilumen.

3. Balloon catheter of claim 1 wherein said catheter tube is multilumen.

4. Balloon catheter of claim 1 wherein said guidewire passage and said inflation/deflation passage are coaxial.

5. Balloon catheter of claim 1 wherein a spring is embedded in said tube substantially along and at least the length of the distal end of said balloon to the proximal end of said balloon.

6. Balloon catheter of claim 1 including means providing a soft tip.

7. Balloon catheter of claim 1 wherein said braided fiber layer reaches a fixed diameter on inflation.

8. Balloon catheter of claim 1 wherein said braided fiber layer provides pressure carrying capability.

9. Balloon catheter of claim 1 wherein said braided fiber layer provides for said balloon to collapse to the same profile after pressurization.

10. Balloon catheter of claim 1 wherein said braided fiber layer and said elastomeric materials provide cyclic durability.

11. Balloon catheter of claim 1 wherein said braided fiber layer assists in steerability.

12. Balloon catheter of claim 1 wherein said braided fiber layer provides for radiopaque viewing.

13. Balloon catheter comprising:

a. a multilumen catheter tube including a guidewire passage and an inflation/deflation passage;

b. a hub including a guidewire entry port and an inflation/deflation port on a proximal end of said catheter tube;

c. tube of elastomeric material including an embedded spring therein extending affixed to the distal end of said catheter tube; and,

d. a balloon fixedly secured to the outer surface of said distal end of said catheter tube at one end of said balloon and fixedly secured to the outer surface of a distal end of said tube at the other end of said balloon, wherein said balloon includes a braided fiber layer located between an inner elastomeric material layer with memory and an outer elastomeric material layer with memory and wherein said braided fiber layer is fixedly secured adjacent said distal end of said catheter tube and fixedly secured adjacent said distal end of said tube.

14. Balloon catheter comprising:

a. a coaxial catheter tube including a guidewire passage and an inflation/deflation passage;

b. a hub including a guidewire entry port and an inflation/deflation port on a proximal end of said catheter tube;

- c. a tube of elastomeric material of short length including an embedded spring extending affixed to the distal end of said catheter tube; and,
 - d. a balloon fixedly secured to the outer surface of said distal end of said catheter tube at one end of said balloon and fixedly secured to the outer surface of a distal end of said tube at the other end of said balloon, wherein said balloon includes a braided fiber layer located between an inner elastomeric material layer with memory and an outer elastomeric material layer with memory and wherein said braided fiber layer is fixedly secured adjacent said distal end of said catheter tube and fixedly secured adjacent said distal end of said tube.
15. Balloon catheter comprising:
- a. a catheter tube including a guidewire passage and an inflation/deflation passage;
 - b. a hub including a guidewire entry port and an inflation/deflation port on a proximal end of said catheter tube;
 - c. a tube of elastomeric material of a short length affixed to the distal end of said catheter tube and including a spring embedded in said tube substantially along and at least the length of the distal end of said balloon to the proximal end of said balloon; and,
 - d. a balloon fixedly secured to the outer surface of said distal end of said catheter tube at one end of said balloon and fixedly secured to the outer surface of a distal end of said tube at the other end of said balloon, wherein said balloon includes a braided fiber layer located between an inner elastomeric material layer with memory and an outer elastomeric material layer with memory and wherein said braided fiber layer is fixedly secured adjacent said distal end of said catheter tube and fixedly secured adjacent said distal end of said tube.
16. Balloon catheter comprising:
- a. a multilumen catheter tube including a guidewire passage and an inflation/deflation passage;

5
10
15
20
25
30
35
40
45
50
55
60
65

- b. a hub including a guidewire entry port and an inflation/deflation port on a proximal end of said catheter tube;
 - c. tube of elastomeric material including an embedded spring therein extending affixed to the distal end of said catheter tube and including a spring embedded in said tube substantially along and at least the length of the distal end of said balloon to the proximal end of said balloon; and,
 - d. a balloon fixedly secured to the outer surface of said distal end of said catheter tube at one end of said balloon and fixedly secured to the outer surface of a distal end of said tube at the other end of said balloon, wherein said balloon includes a braided fiber layer located between an inner elastomeric material layer with memory and an outer elastomeric material layer with memory and wherein said braided fiber layer is fixedly secured adjacent said distal end of said catheter tube and fixedly secured adjacent said distal end of said tube.
17. Balloon catheter comprising:
- a. a coaxial catheter tube including a guidewire passage and an inflation/deflation passage;
 - b. a hub including a guidewire entry port and an inflation/deflation port on a proximal end of said catheter tube;
 - c. a tube of elastomeric material of short length including an embedded spring extending affixed to the distal end of said catheter tube and including a spring embedded in said tube substantially along and at least the length of the distal end of said balloon to the proximal end of said balloon; and,
 - d. a balloon fixedly secured to the outer surface of said distal end of said catheter tube at one end of said balloon and fixedly secured to the outer surface of a distal end of said tube at the other end of said balloon, wherein said balloon includes a braided fiber layer located between an inner elastomeric material layer with memory and an outer elastomeric material layer with memory and wherein said braided fiber layer is fixedly secured adjacent said distal end of said catheter tube and fixedly secured adjacent said distal end of said tube.

* * * * *