

[54] **LOW TEMPERATURE SINTERED CERAMIC CAPACITOR WITH A TEMPERATURE COMPENSATING CAPABILITY, AND METHOD OF MANUFACTURE**

[75] Inventors: **Hirokazu Chazono**, Takasaki; **Hiroshi Kishi**, Fujioka; **Shunji Murai**, Harunamachi; **Masami Fukui**, Gunma; **Takeshi Wada**, Harunamachi, all of Japan

[73] Assignee: **Taiyo Yuden Co., Ltd.**, Tokyo, Japan

[21] Appl. No.: **945,334**

[22] Filed: **Dec. 22, 1986**

[30] **Foreign Application Priority Data**

Dec. 30, 1985 [JP] Japan 60-298003

[51] Int. Cl.⁴ **C04B 35/46; H01G 4/12**

[52] U.S. Cl. **361/321; 264/65**

[58] Field of Search 361/320, 321; 29/25, 29/42; 501/135; 264/61, 65

[56] **References Cited**

U.S. PATENT DOCUMENTS

4,223,369	9/1980	Burn	361/321
4,482,934	11/1984	Hirota et al.	361/321
4,616,289	10/1986	Itakura et al.	361/321
4,626,393	12/1986	Wada et al.	264/65
4,626,396	12/1986	Wada et al.	264/65

FOREIGN PATENT DOCUMENTS

59-227769 12/1984 Japan .

Primary Examiner—Donald A. Griffin

Attorney, Agent, or Firm—Woodcock Washburn Kurtz Mackiewicz & Norris

[57] **ABSTRACT**

A temperature compensating capacitor of monolithic or multilayered configuration comprising a dielectric ceramic body and at least two electrodes buried therein. The ceramic body is composed of a major ingredient expressed by the formula, $\{(Sr_{1-x-y}Ca_xM_y)O\}_k \cdot (Ti_{1-z}Zr_z)O_2$, where M is at least either of magnesium and zinc, and where x, y, k and z are numerals in the ranges of zero to 0.995 inclusive, 0.005 to 0.100 inclusive, 1.00 to 1.04 inclusive, and 0.005 to 0.100 inclusive, respectively. To this major ingredient is added a minor proportion of a mixture of lithium oxide, silicon dioxide, and one or more metal oxides selected from among barium oxide, magnesium oxide, zinc oxide, strontium oxide and calcium oxide. For the fabrication of capacitors the mixture of the above major ingredient and additives in finely divided form are formed into moldings of desired shape and size, each with at least two electrodes buried therein. The moldings and electrodes are cosintered in a reductive or neutral atmosphere and then are reheated at a lower temperature in an oxidative atmosphere. The cosintering temperature can be so low that nickel or like base metal can be employed as the electrode material.

9 Claims, 2 Drawing Figures

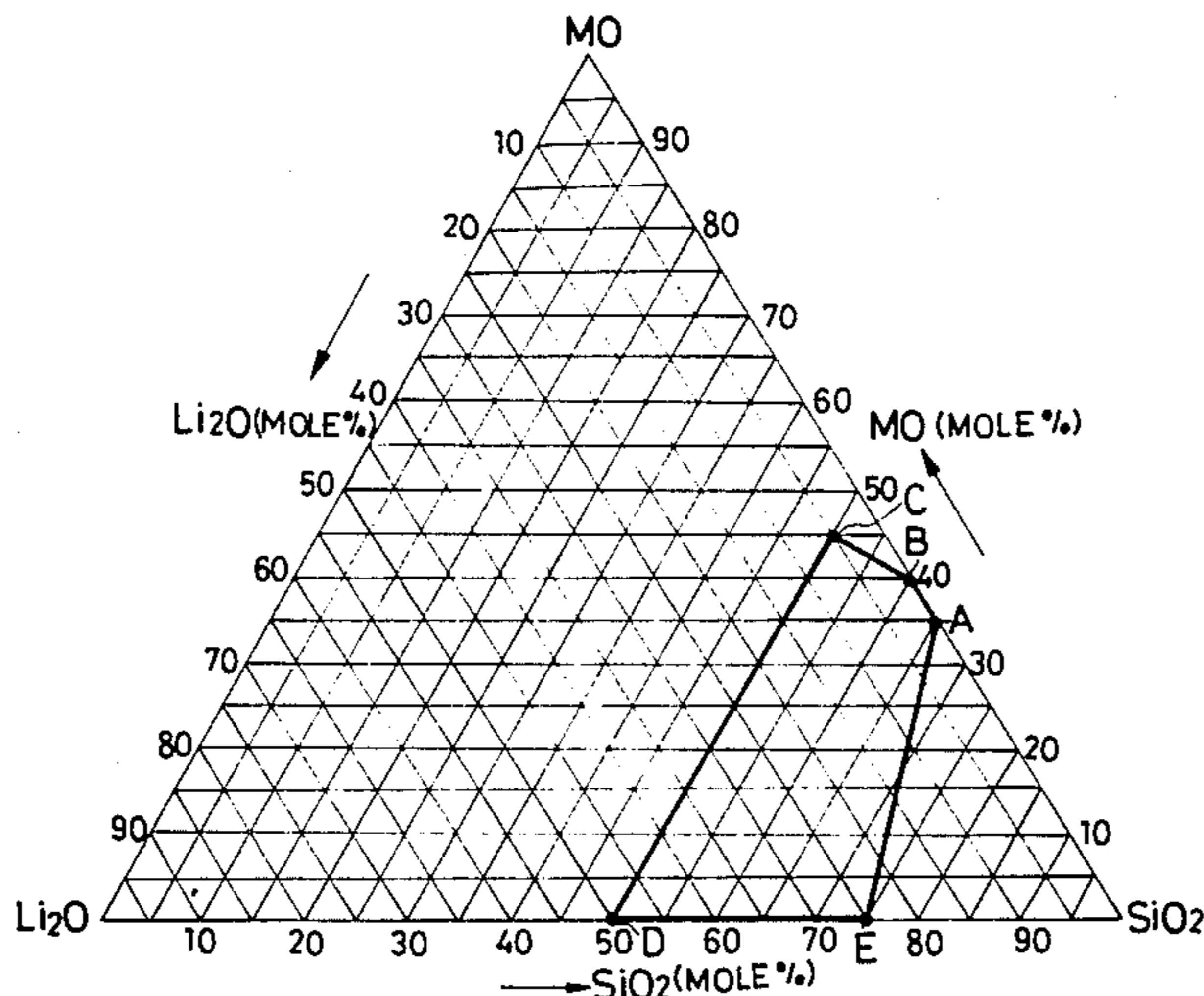

FIG. 1

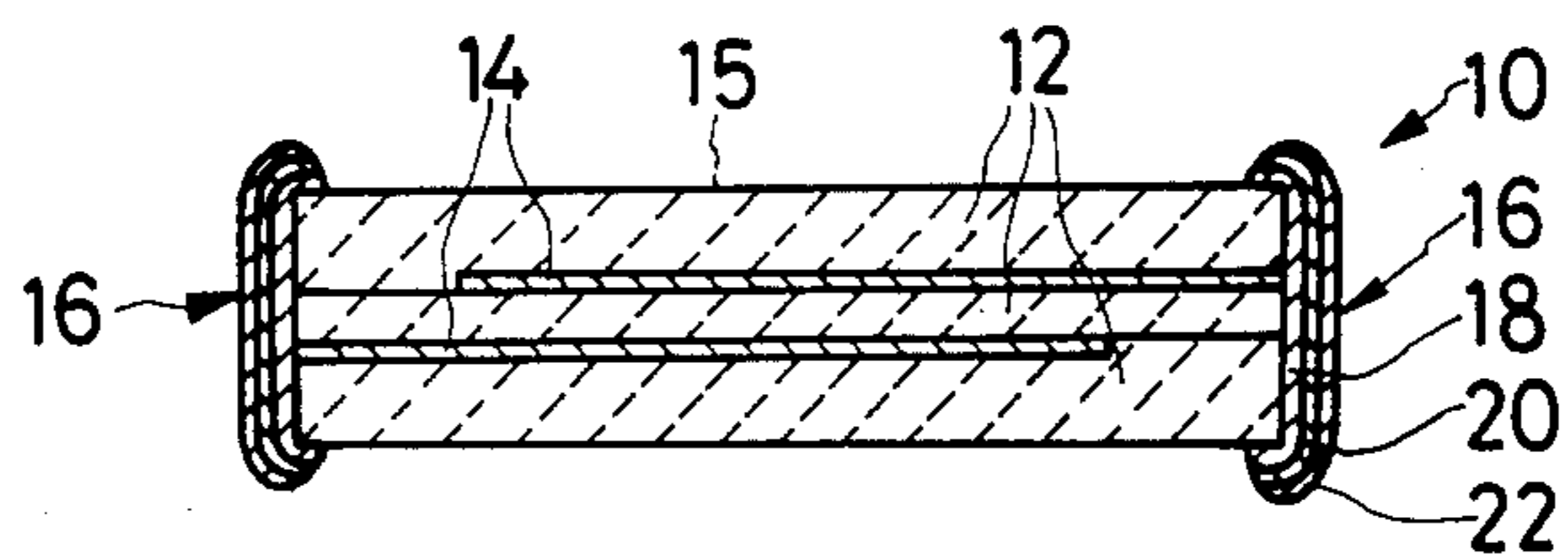
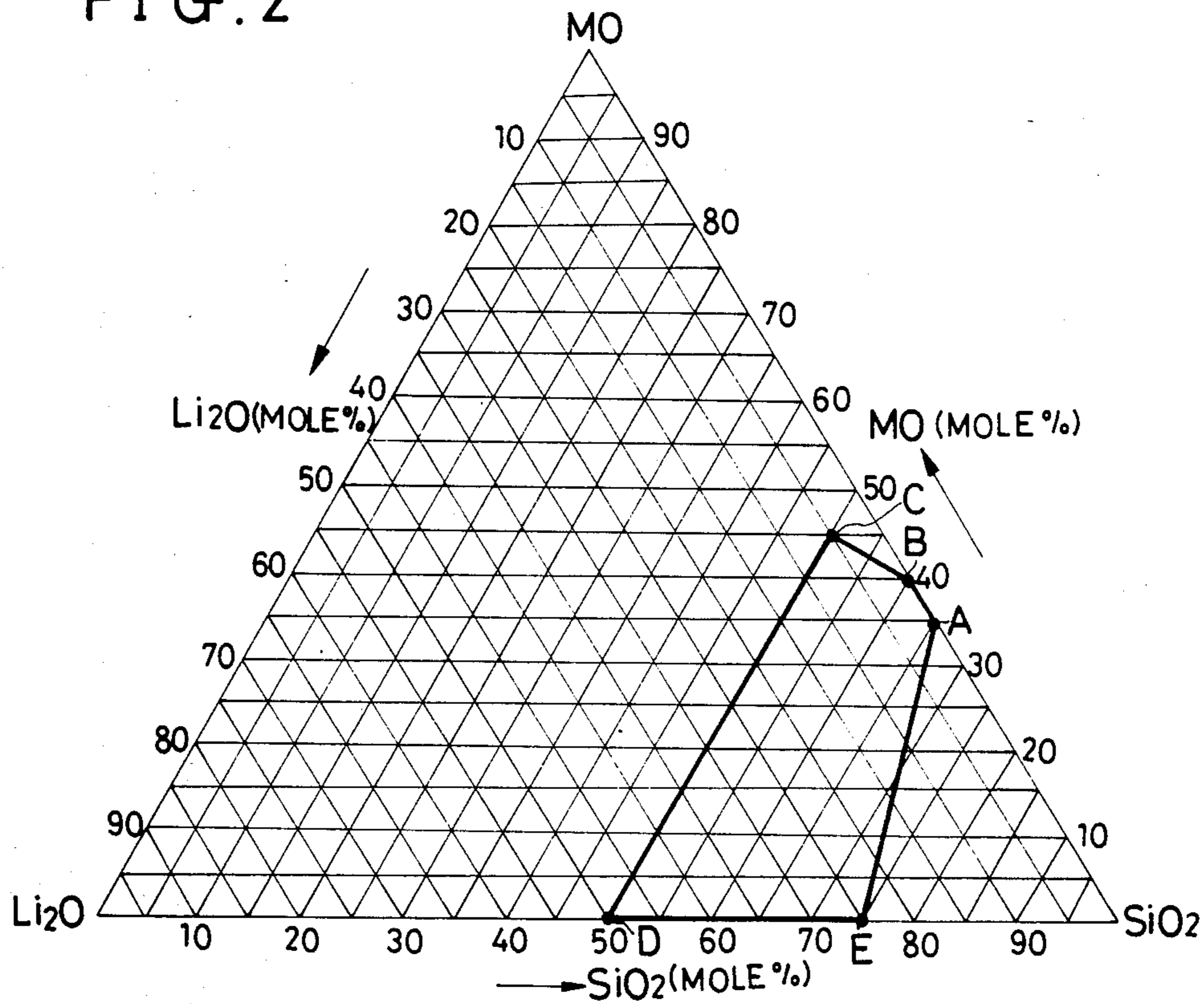

FIG. 2



**LOW TEMPERATURE SINTERED CERAMIC
CAPACITOR WITH A TEMPERATURE
COMPENSATING CAPABILITY, AND METHOD
OF MANUFACTURE**

BACKGROUND OF THE INVENTION

Our invention relates to solid dielectric capacitors, and more specifically to ceramic capacitors such as those of the monolithic, multilayered configuration that are capable of manufacture by cosintering at sufficiently low temperatures to permit the use of base metal electrodes, and to a process for the fabrication of such low temperature sintered capacitors. The ceramic capacitors of our invention are particularly notable for their temperature compensating capability, having a practically constant temperature coefficient of capacitance in the normal range of temperatures in which they are intended for use.

We know several conventional ceramic compositions calculated to permit the use of base metal electrodes in the manufacture of monolithic, multilayered ceramic capacitors by cosintering of the base metal electrodes and the dielectric ceramic bodies. Among such known ceramic compositions, and perhaps most pertinent to our present invention, are those described and claimed in Japanese Laid Open Patent Application No. 59-227769, which compositions comprise a major proportion of a primary ingredient expressed by the formula, $\{(Sr_{1-x}Ca_x)O\}_kTiO_2$, and minor proportions of lithium oxide (Li_2O), silicon dioxide (SiO_2), and one or more of barium oxide (BaO), calcium oxide (CaO), and strontium oxide (SrO). In the manufacture of ceramic capacitors the dielectric bodies of these known compositions are sinterable in a reductive atmosphere, so that electrodes of nickel or like base metal can be employed and buried in the dielectric bodies for cosintering to maturity without the danger of oxidation. The resulting capacitors have a remarkable temperature compensating capability.

However, the temperature compensating capacitors of the above known ceramic composition are unsatisfactory in that their Q factors are less than 4400 when their temperature coefficients of capacitance are in the range of -1000 to $+350$ parts per million (ppm) per degree centigrade (C.). We have been keenly aware of great demands on temperature compensating ceramic capacitors of higher performance characteristics and smaller size.

SUMMARY OF THE INVENTION

We have hereby discovered how to improve the performance characteristics, particularly Q factor and resistivity, of the temperature compensating ceramic capacitors of the class under consideration.

Stated briefly in one aspect thereof, our invention provides a low temperature sintered solid dielectric capacitor comprising a dielectric ceramic body and at least two electrodes in contact therewith. The dielectric ceramic body consists essentially of: (a) 100 parts by weight of $\{(Sr_{1-x-y}Ca_xM_y)O\}_k(Ti_{1-z}Zr_z)O_2$, where M is either or both of magnesium (Mg) and zinc (Zn), x is a numeral in the range of zero to 0.995 inclusive, y a numeral in the range of 0.005 to 0.100 inclusive, k a numeral in the range of 1.00 to 1.04 inclusive, and z a numeral in the range of 0.005 to 0.100 inclusive; and (b) 0.2 to 10.0 parts by weight of an additive mixture of Li_2O , SiO_2 , and at least one metal oxide selected from

the group consisting of BaO , magnesium oxide (MgO), zinc oxide (ZnO), SrO and CaO . The relative proportions of Li_2O , SiO_2 and at least one selected metal oxide, altogether constituting the additive mixture, will be specifically determined in connection with a ternary diagram attached hereto.

The ceramic capacitor of our invention, having its dielectric body formulated as set forth in the foregoing, has proved to be very well suited for temperature compensating applications in oscillator and other circuits. The test capacitors manufactured in accordance with our invention had Q factors of 4500 or more and resistivities of 1.0×10^7 megohm-centimeters or more while at the same time their temperature coefficients of capacitances were both in and outside the range of -1000 to $+350$ ppm per degree C. It is therefore possible to reduce the size of the prior art ceramic capacitors of the noted compositions without sacrifice in their performance characteristics.

Another aspect of our invention concerns a method of fabricating the above defined ceramic capacitor. The method dictates, first of all, the preparation of a mixture of the above indicated proportions of the major ingredient and additives in finely divided form. This mixture is then molded into a body of desired shape and size, which is provided with at least two electrode portions of an electroconductive material in any convenient manner. Then the molding with the electrode portions is sintered in a nonoxidative (i.e. reductive or neutral) atmosphere and is subsequently reheated in an oxidative atmosphere.

We recommend a temperature range of 1000° to 1200° C. for sintering the dielectric molding. This temperature range is sufficiently low to permit the cosintering, in a reductive or neutral atmosphere, of nickel or like base metal electrodes on the dielectric molding without the likelihood of the flocculation or diffusion of the base metal.

The above and other features and advantages of our invention and the manner of realizing them will become more apparent, and the invention itself will best be understood, from a study of the following description and appended claims taken together with the attached drawings.

BRIEF DESCRIPTION OF THE DRAWINGS

FIG. 1 is a sectional representation of a monolithic, multilayered ceramic capacitor in accordance with our invention, the illustrated capacitor being representative of numerous test capacitors fabricated in the Examples of our invention to be presented subsequently; and

FIG. 2 is a ternary diagram depicting the relative proportions of the additives of the ceramic compositions in accordance with our invention.

DETAILED DESCRIPTION

We have illustrated in FIG. 1 one of many monolithic ceramic capacitors of identical construction fabricated in the subsequent Examples of our invention by way of a preferable embodiment thereof. Generally designated 10, the representative capacitor is shown to have an interlamination of three dielectric ceramic layers 12 and two film electrodes 14. The three ceramic layers 12 constitute in combination a solid dielectric body 15 having the low temperature sintered ceramic compositions in accordance with our invention. The two film electrodes 14, which can be of a low cost base metal

TABLE 1-continued

Test No.	Ceramic Compositions						Additives							
	Major Ingredient (100 wt. parts)						Amount (wt. part)	Composition (mole %)			MO (mole %)			
	k	x	y		Total	z		Li ₂ O	SiO ₂	MO	BaO	MgO	ZnO	SrO
49	"	"	0.02	0.01	0.03	"	"	"	"	"	"	"	"	"
50	"	"	0.03	0.02	0.05	"	"	"	"	"	"	"	"	"
51	"	"	0.05	0.05	0.10	"	"	"	"	"	"	"	"	"
52	"	"	0.06	0.06	0.12	"	"	"	"	"	"	"	"	"
53	1.02	0	0.01	0	0.01	0.03	"	"	55	5	"	"	"	"
54	"	"	0.03	"	0.03	"	"	"	"	"	"	"	"	"
55	"	"	0.05	"	0.05	"	"	"	"	"	"	"	"	"
56	"	"	0.10	"	0.10	"	"	"	"	"	"	"	"	"
57	"	"	0.12	"	0.12	"	"	"	"	"	"	"	"	"
58	"	0.995	0	0.005	0.005	"	"	30	60	10	"	"	"	"
59	"	0.97	"	0.03	0.03	"	"	"	"	"	"	"	"	"
60	"	0.95	"	0.05	0.05	"	"	"	"	"	"	"	"	"
61	"	0.90	"	0.10	0.10	"	"	"	"	"	"	"	"	"
62	"	0.88	"	0.12	0.12	"	"	"	"	"	"	"	"	"
63	1.01	0.38	0.01	0.01	0.02	"	0	25	70	5	"	"	"	"
64	"	"	"	"	"	"	0.2	"	"	"	"	"	"	"
65	"	"	"	"	"	"	1	"	"	"	"	"	"	"
66	"	"	"	"	"	"	3	"	"	"	"	"	"	"
67	"	"	"	"	"	"	5	"	"	"	"	"	"	"
68	"	"	"	"	"	"	10	"	"	"	"	"	"	"
69	"	"	"	"	"	"	12	"	"	"	"	"	"	"
70	1.0	0	"	"	"	0	2	20	65	15	"	"	"	"
71	"	"	"	"	"	0.002	"	"	"	"	"	"	"	"
72	"	"	"	"	"	0.005	"	"	"	"	"	"	"	"
73	"	"	"	"	"	0.01	"	"	"	"	"	"	"	"
74	"	"	"	"	"	0.03	"	"	"	"	"	"	"	"
75	"	"	"	"	"	0.05	"	"	"	"	"	"	"	"
76	"	"	"	"	"	0.10	"	"	"	"	"	"	"	"
77	"	"	"	"	"	0.12	"	"	"	"	"	"	"	"
78	"	0.38	"	"	"	0	"	15	60	25	"	"	"	"
79	"	"	"	"	"	0.005	"	"	"	"	"	"	"	"
80	"	"	"	"	"	0.03	"	"	"	"	"	"	"	"
81	"	"	"	"	"	0.05	"	"	"	"	"	"	"	"
82	"	"	"	"	"	0.10	"	"	"	"	"	"	"	"
83	"	"	"	"	"	0.12	"	"	"	"	"	"	"	"
84	"	0.99	"	"	"	0.01	"	"	65	20	"	"	"	"
85	"	0.97	"	"	"	0.03	"	"	"	"	"	"	"	"
86	"	0.95	"	"	"	0.05	"	"	"	"	"	"	"	"
87	"	0.90	"	"	"	0.10	"	"	"	"	"	"	"	"
88	"	0.98	"	"	"	0.12	"	15	65	20	"	"	"	"
89	0.99	0.38	"	0.02	0.03	0.05	"	30	50	20	"	"	"	"
90	1.00	"	"	"	"	"	"	"	"	"	"	"	"	"
91	1.005	"	"	"	"	"	"	"	"	"	"	"	"	"
92	1.01	"	"	"	"	"	"	"	"	"	"	"	"	"
93	1.03	"	"	"	"	"	"	"	"	"	"	"	"	"
94	1.04	"	"	"	"	"	"	"	"	"	"	"	"	"
95	1.05	"	"	"	"	"	"	"	"	"	"	"	"	"

According to Table 1, the major ingredient of the dielectric bodies of the capacitors of Test No. 1 was $\{(Sr_{0.61}Ca_{0.37}Mg_{0.01}Zn_{0.01})O\}_{1.0}(Ti_{0.95}Zr_{0.05})O_2$. One hundred parts of this major ingredient was admixed with 2.0 parts by weight of a mixture of 65 mole percent SiO₂ and 35 mole percent MO. MO was a mixture of 20 percent BaO, 20 mole percent MgO, 20 mole percent ZnO, 20 mole percent SrO and 20 mole percent CaO. Li₂O was not used in this particular Test.

For the fabrication of the capacitors of Test No. 1 we started with the preparation of the major ingredient of their dielectric bodies. We prepared the following start materials:

Strontium carbonate (SrCO₃)
512.68 grams (0.61 mole part)
Calcium carbonate (CaCO₃)
210.66 grams (0.37 mole part)
Magnesium carbonate (MgCO₃)
4.80 grams (0.01 mole part)
Zinc oxide (ZnO)
4.63 grams (0.01 mole part)
Titanium oxide (TiO₂)

432.16 grams (0.95 mole part)
Zirconium oxide (ZrO₂)
35.08 grams (0.05 mole part)

These start materials had all purities of not less than 99.0 percent. The above specified weights of the start materials do not include those of the impurities contained. We charged the start materials into a pot mill together with alumina balls and 2.5 liters of water and mixed them together for 15 hours. Then the mixture was introduced into a stainless steel vat and therein dried by air heated to 150° C. for four hours. Then the dried mixture was crushed into relatively coarse particles, which were subsequently fired in air within a tunnel furnace at 1200° C. for two hours. There was thus obtained the major ingredient of the above specified composition in finely divided form.

For the provision of the additives of Test No. 1 we prepared:

SiO₂ 49.61 grams (65 mole percent)
BaCO₃ 17.55 grams (seven mole percent)

-continued

MgO	3.58 grams (seven mole percent)
ZnO	7.24 grams (seven mole percent)
SrCO ₃	13.13 grams (seven mole percent)
CaCO ₃	8.89 grams (seven mole percent)

To these substances we added 300 cubic centimeters of alcohol, and the resulting slurry was stirred for 10 hours in a polyethylene pot with alumina balls. Then the mixture was air fired at 1000° C. for two hours. Then, charged into an alumina pot together with 300 cubic centimeters of water, the fired mixture was pulverized with alumina balls over a period of 15 hours. Then the pulverized mixture was dried at 150° C. for four hours. There was thus obtained in finely divided form the desired additive mixture of 65 mole percent SiO₂ and 35 mole percent MO, with the MO consisting of seven mole percent BaO, seven mole percent MgO, seven mole percent ZnO, seven mole percent SrO, and seven mole percent CaO.

Twenty grams (two weight percent) of this additive mixture was added to 1000 grams of the above prepared major ingredient. Further, to this mixture, we added 15 percent by weight of an organic binder and 50 percent by weight of water with respect to the total weight of the major ingredient and additives. The organic binder was an aqueous solution of acrylic ester polymer, glycerine, and condensed phosphate. The mixture of all these was ball milled into a slurry. Then this slurry was defoamed in vacuum.

Then the defoamed slurry was charged into a reverse roll coater thereby to be shaped into a thin, continuous strip on an elongate supporting strip of polyester film. Then the strip was dried by heating to 100° C. on the supporting film. The green ceramic strip thus obtained, approximately 25 microns thick, was subsequently punched into "squares" sized 10 by 10 centimeters. These green ceramic squares are to become the ceramic layers 12, FIG. 1, in the completed test capacitors 10.

For the fabrication of the base metal film electrodes 14 on the ceramic layers 12, we prepared 10 grams of nickel in finely divided form, with an average particle size of 1.5 microns, and a solution of 0.9 gram of ethyl cellulose in 9.1 grams of butyl "Carbitol" (trademark for diethylene glycol monobutyl ether). Both were intimately intermingled by being agitated for 10 hours, thereby providing an electroconductive paste. Then this paste was "printed" on one surface of each green ceramic square, which had been prepared as above described, through a screen having 50 perforations of rectangular shape, each sized seven by 14 millimeters.

After drying the printed paste, two green squares were stacked, with their printings directed upwardly, and with the printings on the two squares offset from each other to an extent approximately half the pitch of their patterns in the longitudinal direction. The thus stacked two printed squares were placed between two separate stacks of four unprinted squares each with a thickness of 60 microns. The resulting stack of printed and unprinted squares were pressed in their thickness direction under a pressure of approximately 40 tons at 50° C., thereby firmly bonding the stacked squares to one another. Then the bonded squares were cut in a latticed pattern into 50 laminate chips of identical construction.

We employed a furnace capable of atmosphere control for cofiring the above prepared green dielectric bodies and, buried therein, the conductive layers which

were to become the film electrodes 14 in the completed capacitors 10. The chips were first air heated in this furnace to 600° C., at a rate of 100° C. per hour, thereby driving off the organic binder that had been used for providing the slurry of the powdered major ingredient and additives. Then the furnace atmosphere was changed from air to a reductive (nonoxidative) atmosphere consisting of two percent by volume of molecular hydrogen and 98 percent by volume of molecular nitrogen. In this reductive atmosphere the furnace temperature was raised from 600° C. to 1110° C. at a rate of 100° C. per hour. The maximum temperature of 1110° C., at which the ceramic bodies formulated in accordance with our invention were to be sintered to maturity, was maintained for three hours. Then the furnace temperature was lowered to 600° C. at a rate of 100° C. per hour. Then, with the furnace atmosphere again changed to air (oxidative atmosphere), the temperature of 600° C. was maintained for 30 minutes for the oxidizing heat treatment of the sintered chips. Then the furnace temperature was allowed to drop to room temperature.

There were thus obtained the dielectric ceramic bodies 15, FIG. 1, cosintered with the film electrodes 14 buried therein.

We proceeded to the production of the pair of conductive terminations 16 on both sides of each ceramic body 15 through which are exposed the film electrodes 14. First, for the production of the inmost zinc layers 18, a conductive paste composed of zinc, glass frit and vehicle was coated on both sides of each ceramic body 15. The coatings on drying were air heated to 550° C. and maintained at that temperature for 15 minutes, thereby completing the zinc layers 18 each in direct contact with one of the two film electrodes 14. Then the intermediate copper layers 20 were formed over the zinc layers 18 by electroless plating. Then the outermost solder layers 22 were formed by electroplating a lead tin alloy over the copper layers 20.

We have thus completed the fabrication of monolithic, multilayered ceramic test capacitors, each constructed as in FIG. 1, in accordance with the ceramic composition of Test No. 1 of Table 1. The composition of the ceramic bodies 15 of the thus completed capacitors proved substantially akin to that before sintering. It is therefore reasoned that the sintered ceramic bodies 15 are of perovskite structures, with the additives (65 mole percent SiO₂, seven mole percent BaO, seven mole percent MgO, seven mole percent ZnO, seven mole percent SrO, and seven mole percent CaO) uniformly dispersed among the crystal grains of the major ingredient.

As for the other ceramic compositions of Table 1, designated Tests Nos. 2 through 95, we made similar test capacitors through exactly the same procedure as that set forth in the foregoing in connection the Test No. 1 composition, except for the temperature of sintering in the reductive atmosphere, which will be referred to presently.

All the capacitors of Test Nos. 1 through 95 were then tested as to their specific dielectric constants, temperature coefficients, Q factors, and resistivities. The following are the methods we employed for the measurement of these properties:

Specific Dielectric Constant

The capacitance of each test capacitor was first measured at a temperature of 20° C., a frequency of one megahertz, and an effective alternating current voltage of 0.5 volt. Then the specific dielectric constant was computed from the measured value of capacitance, the area (25 square millimeters) of each of the overlapping parts of the two film electrodes 14, and the thickness (0.05 millimeter) of that ceramic layer 12 which intervenes between the film electrodes.

Temperature Coefficient of Capacitance

The capacitance C₈₅ at 85° C. and capacitance C₂₀ at 20° C. of each test capacitor were first measured. Then the temperature coefficient TC of capacitance was computed by the equation

$$TC = \frac{C_{85} - C_{20}}{C_{20}} \times \frac{1}{65} \times 10^6 \text{ (ppm/°C.)}$$

Q Factor

The Q factor was measured by a Q meter at a frequency of one megahertz, a temperature of 20° C., and an effective alternating current voltage of 0.5 volt.

Resistivity

Resistance between the pair of conductive terminations 16 of each test capacitor was measured after the application of a direct current voltage of 50 volts for one minute at a temperature of 20° C. Then the resistivity was computed from the measured resistance value and the size of the test capacitors.

Table 2 gives the results of the measurements by the above described methods, as well as the maximum temperatures at which the test capacitors were sintered in the reductive atmosphere during their manufacture. It will be noted from this table that the specific dielectric constants of the Test No. 1 capacitors, for instance, averaged 267, their temperature coefficients of capacitances -1060 ppm per degree C., their Q factors 10,000, and their resistivities 2.3 × 10⁷ megohm-centimeters. The temperature coefficients of the capacitances of the test capacitors were practically constant in the normal range of their operating temperatures, making the capacitors well suited for use as temperature compensating capacitors.

TABLE 2

Firing Temperature & Capacitor Characteristics					
Electrical Properties					
Test No.	Firing Temp. (°C.)	Specific Dielectric Constant	Temperature Coefficient of Capacitance (ppm/°C.)	Q Factor	Resistivity (megohm-cm)
1	1110	267	-1060	10000	2.3 × 10 ⁷
2	"	"	-1070	"	2.4 × 10 ⁷
3	"	265	-1050	10500	2.5 × 10 ⁷
4	"	"	-1040	"	"
5	"	260	-1050	9800	2.2 × 10 ⁷
6	"	"	"	9900	2.3 × 10 ⁷
7	"	265	-1040	10500	2.5 × 10 ⁷
8	1270	Not coherently bonded on firing.			
9	"	"			
10	"	"			
11	"	"			
12	"	"			
13	"	"			
14	"	"			
15	1110	270	-1070	11000	2.7 × 10 ⁷

TABLE 2-continued

Firing Temperature & Capacitor Characteristics					
Electrical Properties					
Test No.	Firing Temp. (°C.)	Specific Dielectric Constant	Temperature Coefficient of Capacitance (ppm/°C.)	Q Factor	Resistivity (megohm-cm)
16	"	266	"	10900	3.0 × 10 ⁷
17	"	258	-1040	10000	2.1 × 10 ⁷
18	"	262	-1050	11000	2.6 × 10 ⁷
19	"	260	-1060	"	2.7 × 10 ⁷
20	"	265	-1050	10800	2.5 × 10 ⁷
21	"	260	-1040	10500	2.2 × 10 ⁷
22	"	261	-1050	"	"
23	"	265	-1060	10700	2.4 × 10 ⁷
24	1100	263	-1050	10600	2.3 × 10 ⁷
25	"	"	"	10500	"
26	1110	261	-1030	10600	2.1 × 10 ⁷
27	1120	260	-1070	10800	2.2 × 10 ⁷
28	1090	330	-3450	12000	8.0 × 10 ⁷
29	1100	300	-2200	11000	5.0 × 10 ⁷
30	1110	260	-1070	10600	2.5 × 10 ⁷
31	1110	210	-1400	9800	4.3 × 10 ⁷
32	1100	180	-2000	8300	1.3 × 10 ⁸
33	1150	230	-900	8200	9.5 × 10 ⁶
34	1140	235	-910	8300	9.7 × 10 ⁶
35	1130	241	-960	8900	1.3 × 10 ⁷
36	1120	250	-1000	9100	1.6 × 10 ⁷
37	1100	320	-1100	10800	5.0 × 10 ⁷
38	1120	260	-1050	10400	1.6 × 10 ⁷
39	1290	Not coherently bonded on firing.			
40	1150	250	-900	9800	9.7 × 10 ⁶
41	1130	252	-900	10000	1.7 × 10 ⁷
42	1120	255	-950	10300	1.9 × 10 ⁷
43	1110	265	-850	11300	2.8 × 10 ⁷
44	1100	325	-750	10700	3.2 × 10 ⁷
45	1120	300	-700	9000	1.7 × 10 ⁷
46	1270	Not coherently bonded on firing.			
47	1120	260	-1000	10000	2.0 × 10 ⁷
48	1110	262	-1100	10500	2.4 × 10 ⁷
49	"	269	-1140	10700	3.4 × 10 ⁷
50	"	327	-1200	10900	4.0 × 10 ⁷
51	1120	286	-1170	9500	2.0 × 10 ⁷
52	1260	Not coherently bonded on firing.			
53	1100	310	-3300	10400	5.0 × 10 ⁷
54	"	"	-3350	11400	7.0 × 10 ⁷
55	1090	360	-3450	11600	6.0 × 10 ⁷
56	1130	320	-3700	11400	3.0 × 10 ⁷
57	1260	Not coherently bonded on firing.			
58	1110	145	-1850	10800	7.0 × 10 ⁷
59	"	165	-1750	11800	1.0 × 10 ⁸
60	"	200	-1650	11200	9.0 × 10 ⁷
61	1140	"	-1450	9000	6.0 × 10 ⁷
62	1250	Not coherently bonded on firing.			
63	1300	"			
64	1170	248	-1015	10400	2.1 × 10 ⁷
65	1140	247	-1000	10500	2.0 × 10 ⁷
66	1120	245	-980	10000	2.2 × 10 ⁷
67	1090	240	-970	7500	2.0 × 10 ⁷
68	1070	228	-950	4700	1.7 × 10 ⁷
69	1050	220	-940	1070	1.3 × 10 ⁷
70	1160	278	-3200	9200	9.8 × 10 ⁶
71	1150	280	-3210	9300	9.9 × 10 ⁶
72	1130	290	-3230	10600	2.0 × 10 ⁷
73	1120	298	-3200	10900	2.5 × 10 ⁷
74	1110	310	-3250	11200	5.5 × 10 ⁷
75	1100	330	-3450	12000	8.0 × 10 ⁷
76	1130	325	-3650	11600	8.5 × 10 ⁷
77	1260	Not coherently bonded on firing.			
78	1150	230	-930	8700	9.5 × 10 ⁶
79	1130	239	-960	9100	1.2 × 10 ⁷
80	1120	245	-10000	10000	2.2 × 10 ⁷
81	"	265	-1200	10500	2.5 × 10 ⁷
82	1110	257	-1400	10300	5.0 × 10 ⁷
83	1290	Not coherently bonded on firing.			
84	1130	141	-1860	6300	8.1 × 10 ⁷
85	1120	150	-1900	6700	1.0 × 10 ⁸
86	1100	180	-2000	8300	1.3 × 10 ⁸
87	1130	168	-2150	6100	1.4 × 10 ⁸
88	1280	Not coherently bonded on firing.			
89	1130	281	-570	2100	4.1 × 10 ³
90	1120	267	-1170	11000	1.1 × 10 ⁷

TABLE 2-continued

Firing Temperature & Capacitor Characteristics					
Electrical Properties					
Test No.	Firing Temp. (°C.)	Specific Dielectric Constant	Temperature Coefficient of Capacitance (ppm/°C.)	Q Factor	Resistivity (megohm-cm)
91	"	270	-1165	10800	2.0×10^7
92	1110	272	-1175	10900	3.4×10^7
93	"	275	-1180	10700	3.6×10^7
94	1120	276	-1190	10000	3.5×10^7
95	1260	Not coherently bonded on firing.			

It will be observed from Table 2 that the dielectric bodies of Tests Nos. 8-14, 39, 46, 52, 57, 62, 63, 77, 83, 88 and 95 were not coherently bonded on firing at temperatures as high as 1250° to 1300° C. in the reductive atmosphere. The corresponding ceramic compositions of Table 1 fall outside the scope of our invention. The dielectric bodies of all the other Tests could be sintered to maturity at temperatures less than 1200° C.

Before proceeding further with the examination of the results of Table 2 we will determine the acceptable criteria of the four electrical properties in question for the temperature compensating ceramic capacitors provided by our invention. These criteria are:

Specific dielectric constant:

From 141 to 360.

Temperature coefficient of capacitance:

From -3700 to -700 ppm per degree C.

Q factor:

Not less than 4700.

Resistivity:

Not less than 1.0×10^7 megohm-centimeters.

A reconsideration of Table 1 in light of the above established criteria of favorable electrical characteristics will reveal that the capacitors of Tests Nos. 33, 33, 40, 69-71, 78 and 89 do not meet these criteria. Accordingly, the corresponding ceramic compositions of Table 1 also fall outside the scope of our invention. All the test capacitors but those of Tests Nos. 8-14, 33, 34, 39, 40, 46, 52, 57, 62, 63, 69-71, 77, 78, 83, 88, 89 and 95 satisfy the criteria, so that their ceramic compositions are in accord with our invention.

Now, let us study the ceramic compositions of Table 1 and the corresponding capacitor characteristics, as well as the sintering temperatures, of Table 2 in more detail. The ceramic compositions of Test No. 63 contained no additive specified by our invention. The dielectric bodies formulated accordingly were not coherently bonded on firing at a temperature as high as 1300° C. Consider the ceramic compositions of Test No. 64 for comparison. They contained 0.2 part by weight of the additives with respect to 100 parts by weight of the major ingredient. Even though the firing temperature was as low as 1170° C., the resulting test capacitors possess the desired electrical characteristics. We set, therefore, the lower limit of the possible proportions of the additive mixture at 0.2 part by weight with respect to 100 parts by weight of the major ingredient.

The Test No. 69 ceramic composition contained as much as 12 parts by weight of the additives with respect to 100 parts by weight of the major ingredient. The resulting capacitors have an average Q factor of 1070, far less than the above established criterion of 4700. When the proportion of the additive mixture was reduced to 10 parts by weight, as in Test No. 68, the resulting capacitors have all the desired characteristics. Therefore, the upper limit of the possible proportions of

the additive mixture is set at 10 parts by weight with respect to 100 parts by weight of the major ingredient.

As for the major ingredient, the value of x was variously determined from zero to 0.995 in Tests Nos. 28-32, and 58. The characteristics of the resulting capacitors all came up to the above criteria. The value of x can thus be anywhere between these limits.

The value of y was set at 0.002 in Tests Nos. 34 and 40. The characteristics of the resulting capacitors were unsatisfactory, reflecting no effect of the use of Mg or Zn in the major ingredient. When the value of y was increased to 0.005 as in Tests Nos. 35 and 41, the resulting capacitors had all the desired characteristics. We set, therefore, the lowermost value of y at 0.005. The value of y was made as high as 0.12 in Tests Nos. 39, 46, 52, 57 and 62. The resulting dielectric bodies were not coherently bonded on firing at temperatures far above 1250° C. The capacitors of the desired characteristics could be obtained when the value of y was decreased to 0.10 as in Tests Nos. 38, 45, 51, 56 and 61. The upper limit of the possible values of y is therefore 0.10.

The value of k in the formula of the major ingredient was set at 0.99 in Test No. 89. The resistivities of the resulting capacitors averaged 4.1×10^3 much lower than the desired lower limit of 1.0×10^7 . The above criteria were all satisfied when the value k was increased to 1.00 as in Test No. 90. The lowermost possible value of k is therefore 1.00. On the other hand, when the value of k was made as much as 1.05 as in Test No. 95, the resulting dielectric bodies were not coherently bonded on firing at as high a temperature as 1260° C. The desired electrical characteristics were obtained when the value of k was reduced to 1.04 as in Test No. 94. Accordingly, the greatest possible value of k is 1.04.

The value of z in the formula of the major ingredient was set at 0.002 in Test No. 71. The characteristics of the resulting capacitors reflect no advantage accruing from the use of ZrO₂ in the major ingredient. When the value of z was increased to 0.005 as in Tests Nos. 72 and 79, all the desired characteristics could be obtained. The lowermost possible value of z is therefore 0.005. On the other hand, when the value of z was made as much as 0.12 as in Tests Nos. 77, 83 and 88, the resulting dielectric bodies were not coherently bonded on firing at temperatures as high as 1260 and more. The desired characteristics were all realized when the value of z was reduced to 0.100 as in Tests Nos. 76, 82 and 87. The greatest possible value of z is therefore 0.100.

We have ascertained from the results of Table 2 that the acceptable range of the relative proportions of Li₂O, SiO₂ and MO, the additives of the ceramic compositions in accordance with our invention, can be definitely stated in reference to the ternary diagram of FIG. 2.

The point A in the ternary diagram indicates the Test No. 1 additive composition of zero mole percent Li₂O, 65 mole percent SiO₂ and 35 mole percent MO. The point B indicates the Test No. 2 additive composition of zero mole percent Li₂O, 60 mole percent SiO₂ and 40 mole percent MO. The point C indicates the Test No. 3 additive composition of five mole percent Li₂O, 45 mole percent SiO₂ and 50 mole percent MO. The point D indicates the Test No. 5 additive composition of 50 mole percent Li₂O, 50 mole percent SiO₂ and zero mole percent MO. The point E indicates the Test No. 6 additive composition of 25 mole percent Li₂O, 75 mole percent SiO₂ and zero mole percent MO.

The relative proportions of the additives Li_2O , SiO_2 and MO of the ceramic compositions in accordance with our invention are within the region bounded by the lines sequentially connecting the above stated points A, B, C, D and E in the ternary diagram of FIG. 2.

Tables 1 and 2 prove that the additive compositions within the above defined region makes possible the provision of capacitors of the desired electrical characteristics. The additive compositions of Tests Nos. 8-14 all fall outside that region, and the corresponding dielectric bodies were not coherently bonded on firing at a temperature of 1270°C . The above specified acceptable range of the relative proportions of the additives holds true regardless of whether only one of BaO , MgO , ZnO , SrO and CaO is employed as MO , as in Tests Nos. 15-19, or two or more or all of them are employed in suitable relative proportions as in other Tests.

Although we have disclosed our invention in terms of specific Examples thereof, we understand that our invention is not to be limited by the exact details of such disclosure but admits of a variety of modifications or alterations within the usual knowledge of the ceramists, chemists or electricians without departing from the scope of the invention. The following, then, is a brief list of such possible modifications or alterations:

1. The low temperature sinterable ceramic compositions of our invention may include various additives not disclosed herein. An example is a mineralizer such as manganese dioxide. Used in a proportion (preferably from 0.05 to 0.10 percent by weight) not adversely affecting the desired characteristics of the resulting capacitors, such a mineralizer will lead to the improvement of sinterability.

2. The start materials of the ceramic compositions in accordance with our invention may be substances such as oxides or hydroxides other than those employed in the foregoing Examples.

3. The temperature of the oxidizing heat treatment need not necessarily be 600°C . but can be variously determined in a range (from 500° to 1000°C . for the best results) not exceeding the temperature of the preceding sintering in a nonoxidative atmosphere, the oxidizing temperature being dependent upon factors such as the particular base metal electrode material in use and the degree of oxidation required for the ceramic material.

4. The temperature of cosintering in a nonoxidative atmosphere may also be changed in consideration of the particular electrode material in use. We recommend a range of 1050° to 1200°C . if the electrode material is nickel, as we have ascertained from experiment that little or no flocculation of the nickel particles takes place in that temperature range.

5. The dielectric bodies and electrodes may be cosintered in a neutral, instead of reductive, atmosphere.

6. The ceramic compositions disclosed herein may be employed for capacitors other than those of the multi-layered configuration.

We claim:

1. A low temperature sintered solid dielectric capacitor comprising a dielectric ceramic body and at least two electrodes in contact therewith, the dielectric ceramic body consisting essentially of:

(a) 100 parts by weight of a major ingredient expressed by the formula,

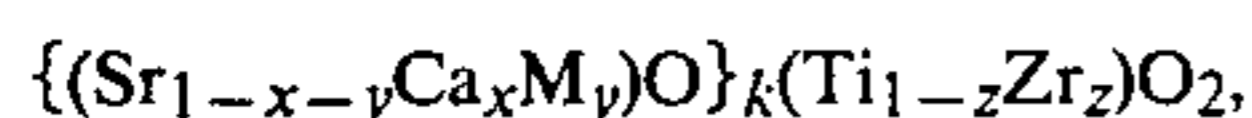

where

M is at least either of magnesium and zinc;
x is a numeral in the range of zero to 0.995 inclusive;

y is a numeral in the range of 0.005 to 0.100;

k is a numeral in the range of 1.00 to 1.04 inclusive; and

z is a numeral in the range of 0.005 to 0.100 inclusive; and

(b) from 0.2 to 10.0 parts by weight of an additive mixture of lithium oxide, silicon dioxide and at least one metal oxide selected from the group consisting of barium oxide, magnesium oxide, zinc oxide, strontium oxide and calcium oxide, the relative proportions of lithium oxide, silicon dioxide and at least one selected metal oxide constituting the additive mixture being in that region of the ternary diagram of FIG. 2 attached hereto which is bounded by the lines sequentially connecting:

the point A where the additive mixture consists of zero mole percent lithium oxide, 65 mole percent silicon dioxide, and 35 mole percent metal oxide;

the point B where the additive mixture consists of zero mole percent lithium oxide, 60 mole percent silicon dioxide, and 40 mole percent metal oxide;

the point C where the additive mixture consists of five mole percent lithium oxide, 50 mole percent silicon dioxide, and 45 mole percent metal oxide;

the point D where the additive mixture consists of 50 mole percent lithium oxide, 50 mole percent silicon dioxide, and zero mole percent metal oxide; and

the point E where the additive mixture consists of 25 mole percent lithium oxide, 75 mole percent silicon dioxide, and zero mole percent metal oxide.

2. A low temperature sintered solid dielectric capacitor as set forth in claim 1, wherein the electrodes are buried in the dielectric ceramic body.

3. A low temperature sintered solid dielectric capacitor as set forth in claim 1, wherein the electrodes are of a base metal.

4. A low temperature sintered solid dielectric capacitor as set forth in claim 3, wherein the base metal is nickel.

5. A process for the manufacture of a low temperature sintered solid dielectric capacitor, which process comprises:

(a) providing a mixture of:

100 parts by weight of a major ingredient, in finely divided form, that is expressed by the formula,

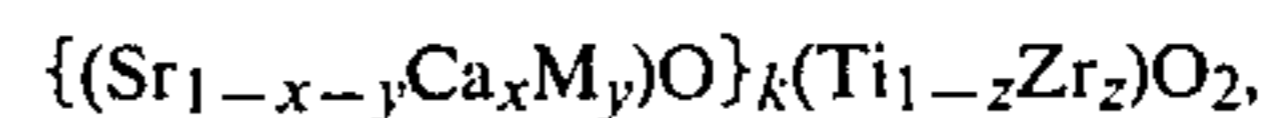

where

M is at least either of magnesium and zinc;
x is a numeral in the range of zero to 0.995 inclusive;

y is a numeral in the range of 0.005 to 0.100 inclusive;

k is a numeral in the range of 1.00 to 1.04 inclusive; and

z is a numeral in the range of 0.005 to 0.100 inclusive;

from 0.2 to 10.0 parts by weight of an additive mixture, in finely divided form, of lithium oxide, silicon dioxide and at least one metal oxide selected from the group consisting of barium ox-

15

ide, magnesium oxide, zinc oxide, strontium oxide and calcium oxide, the relative proportions of boric oxide, silicon dioxide and at least one selected metal oxide constituting the additive mixture being in that region of the ternary diagram of FIG. 2 attached hereto which is bounded by the lines sequentially connecting:

the point A where the additive mixture consists of zero mole percent lithium oxide, 65 mole percent silicon dioxide, and 35 mole percent metal oxide;

the point B where the additive mixture consists of zero mole percent lithium oxide, 60 mole percent silicon dioxide, and 40 mole percent metal oxide;

the point C where the additive mixture consists of five mole percent lithium oxide, 50 mole percent silicon dioxide, and 45 mole percent metal oxide;

the point D where the additive mixture consists of 50 mole percent lithium oxide, 50 mole percent silicon dioxide, and zero mole percent metal oxide; and

the point E where the additive mixture consists of 25 mole percent lithium oxide, 75 mole

16

percent silicon dioxide, and zero mole percent metal oxide;

(b) molding the mixture into desired shape and size, the molding having at least two electrode portions of an electroconductive material;

(c) cosintering the molding and the electrode portions to maturity in a nonoxidative atmosphere; and

(d) reheating the cosintered molding and electrode portions in an oxidative atmosphere.

6. A process for the manufacture of a low temperature sintered solid dielectric capacitor as set forth in claim 5, wherein the electrode portions are formed on the molding by coating the same with an electroconductive paste composed principally of a base metal.

7. A process for the manufacture of a low temperature sintered solid dielectric capacitor as set forth in claim 6, wherein the base metal is nickel.

8. A process for the manufacture of a low temperature sintered solid dielectric capacitor as set forth in claim 5, wherein the molding and the electrode portions are cosintered to maturity in a temperature range of 1000° to 1200° C.

9. A process for the manufacture of a low temperature sintered solid dielectric capacitor as set forth in claim 5, wherein the cosintered molding and electrode portions are reheated in a temperature range of 500° to 1000° C.

* * * * *

30

35

40

45

50

55

60

65

UNITED STATES PATENT AND TRADEMARK OFFICE
CERTIFICATE OF CORRECTION

PATENT NO. : 4,700,267

DATED : Oct. 13, 1987

INVENTOR(S) : Chazono et al.

It is certified that error appears in the above-identified patent and that said Letters Patent is hereby corrected as shown below:

Col 10, Test No. 29, last number of line, change "19" to -- 10⁷ --.

Col 10, Test No. 80, third column of numbers, change "-10000" to -- -1000 --.

Signed and Sealed this
Twentieth Day of December, 1988

Attest:

DONALD J. QUIGG

Attesting Officer

Commissioner of Patents and Trademarks