

United States Patent [19]

Giguere

[11] Patent Number: **4,625,479**

[45] Date of Patent: **Dec. 2, 1986**

- [54] CASING WINDOW
- [75] Inventor: **Jean-Paul Giguere**, Lotbiniere, Canada
- [73] Assignee: **Donat Flamand Inc.**, Lotbiniere, Canada
- [21] Appl. No.: **631,101**
- [22] Filed: **Jul. 16, 1984**
- [51] Int. Cl.⁴ **E06B 7/12; E06B 3/58**
- [52] U.S. Cl. **52/202; 52/203; 52/775; 52/766**
- [58] Field of Search **52/202, 203, 208, 772, 52/766, 775**

3,947,997	4/1976	Mursula .	
3,964,225	6/1976	Yoshida	52/766
3,971,178	7/1976	Mazzoni et al.	52/203 X
4,121,394	10/1978	Brooks .	
4,351,137	9/1982	Enyart et al. .	

FOREIGN PATENT DOCUMENTS

1092181	11/1960	Fed. Rep. of Germany	52/775
1509557	5/1969	Fed. Rep. of Germany	52/775
2334802	1/1974	Fed. Rep. of Germany	52/775
2354169	5/1974	Fed. Rep. of Germany	52/775
2401496	7/1975	Fed. Rep. of Germany	52/775

Primary Examiner—John E. Murtagh
 Assistant Examiner—Richard E. Chilcot, Jr.
 Attorney, Agent, or Firm—Cushman, Darby & Cushman

[56] **References Cited**
U.S. PATENT DOCUMENTS

1,282,490	10/1918	Sullwold .	
2,003,982	6/1935	Swanson .	
2,025,198	12/1935	Conrow .	
2,042,077	5/1936	Stoneback .	
2,164,815	7/1939	Hadjisky .	
2,288,465	6/1942	Knudsen .	
2,642,632	6/1953	Savage	52/775 X
2,923,982	2/1960	Burkland .	
2,925,862	2/1960	Sundby .	
2,960,734	11/1960	Collins .	
3,698,148	10/1972	Marantier	52/775 X
3,858,377	1/1975	Browne et al.	52/775

[57] **ABSTRACT**

A system for mounting a relatively thick multiple glazed sealed unit to a wooden sash assembly of a standard thickness. The system comprises a peripheral base member inserted between the glazed unit and the sash of the window and a retaining moulding engaged to the peripheral base member and pressing the glazed unit in the sash to hold it in place. A suitable weather strip is applied between the glazed unit and the retaining moulding to prevent air infiltration.

6 Claims, 2 Drawing Figures

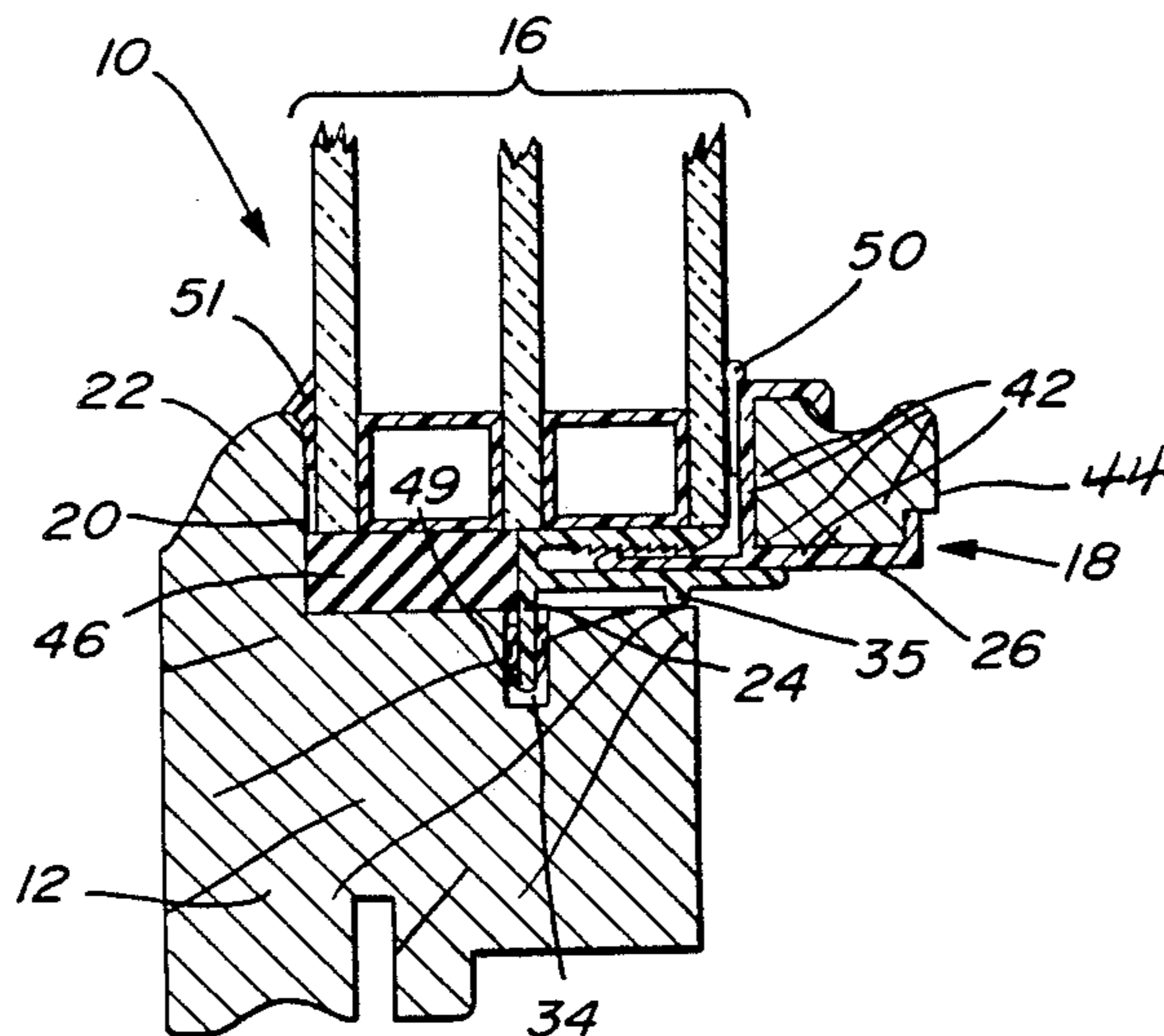

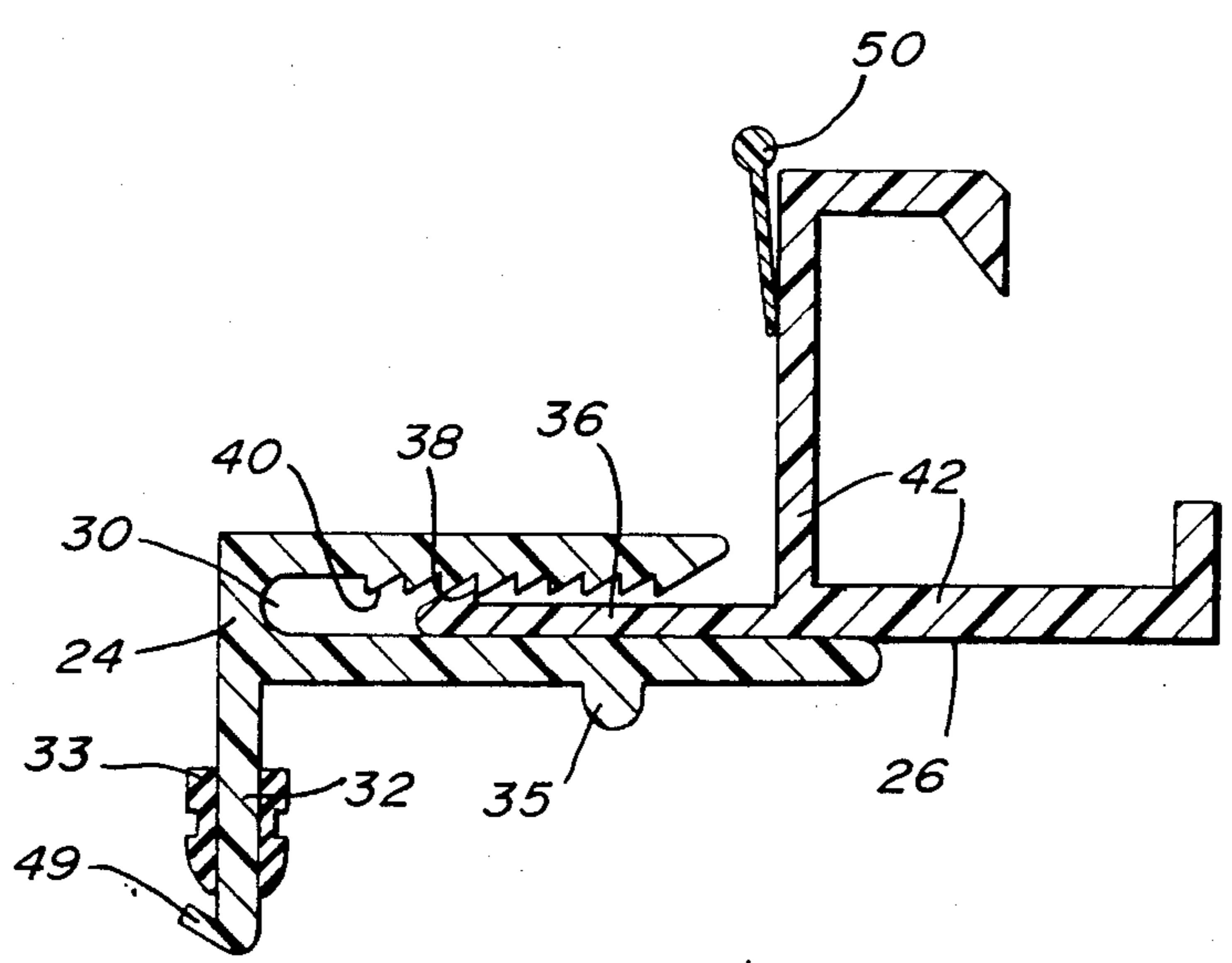
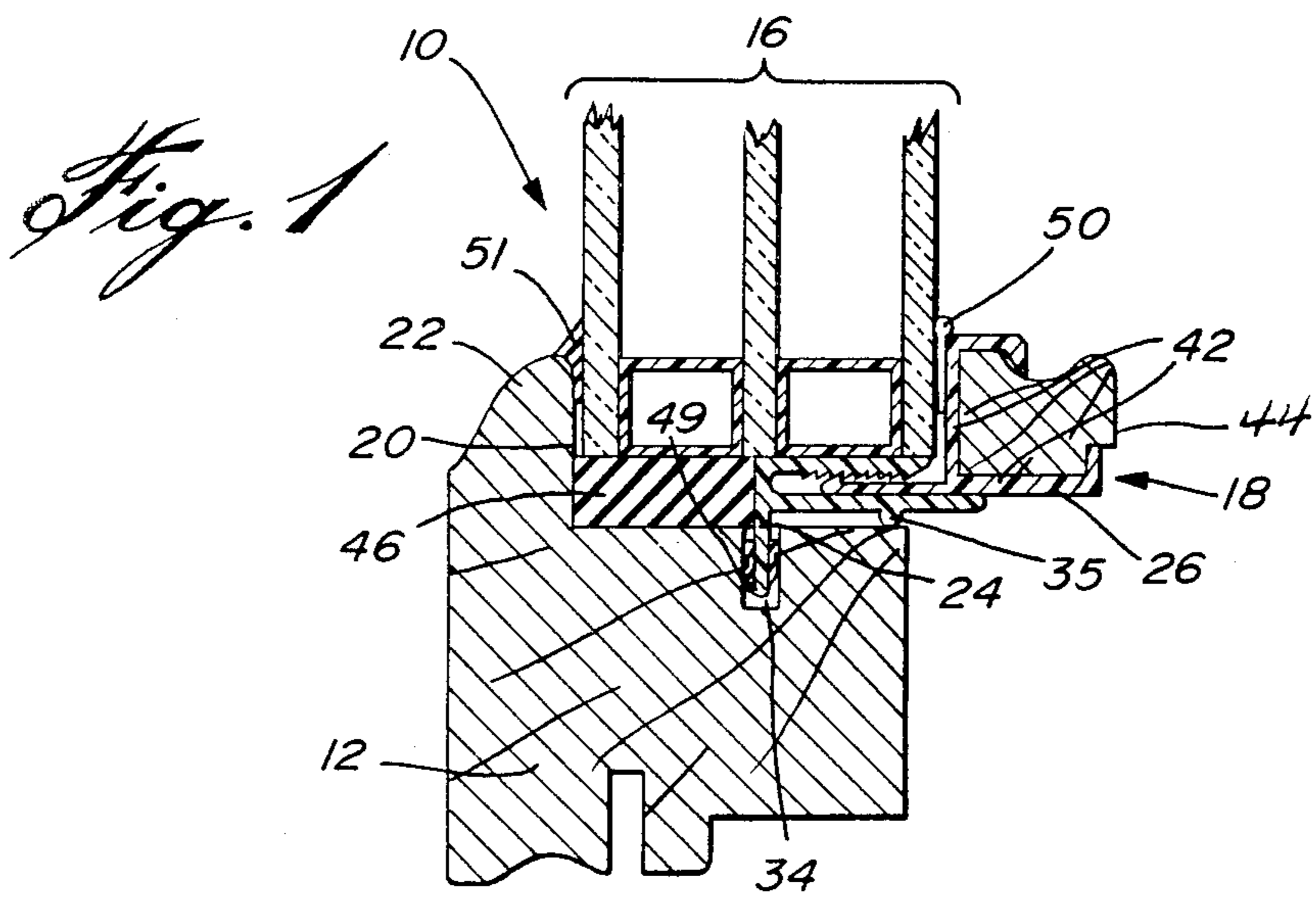

Fig. 2

CASING WINDOW

FIELD OF THE INVENTION

The present invention relates to a device for mounting a relatively thick multiple glazed sealed unit in a wooden sash having a normal thickness.

BACKGROUND OF THE INVENTION

Ordinary double glazed sealed units normally have a thickness of approximately 20 mm. When better thermal protection is required, thick triple glazed sealed units may be used, which feature air spaces of about 12 mm each. These triple glazed units present excessive thickness for use in normal sashes having a 20 mm rabbet.

As used herein, the term "thick multiple glazed units" designates a sealed glazing assembly of at least two glass panes spaced relative to each other and forming an insulating units having a thickness in the 30 to 40 mm range, and adapted to be mounted in a sash. This expression includes triple glazed units comprising two air spaces of 13 mm each. This particular triple glazed unit turns out to be very efficient and it is increasingly popular. It has a thickness of approximately 38 mm.

With the increasing heating costs, thermal insulation of dwellings has become a major preoccupation. Air infiltration through windows must be reduced, and glass units of improved thermal efficiency are required. Double glazed units have become quite popular but triple glazed units are now generating more than a passing interest due to the increase of heating costs. In recent years, the use of triple glazed units has been in substantial demand in areas of harsh climates.

Thick multiple glazed units, including triple glazed units featuring 13 mm air spaces, provide the required degree of thermal insulation but their excess thickness creates a very serious problem due to insufficient space in the sashes and in the window frames of ordinary construction. For instance, thick triple glazed units do not fit in double glazed sashes on account of insufficient rabbet depth, and this is also true for the jamb. This problem becomes particularly acute in the case of casing windows when room is required to accommodate the swinging of the sash around its hinges. Increasing the sash thickness will result in complete inoperativeness of the window since the sash could not pivot in the jamb.

Thus, one may use thin triple glazed units having two air spaces of reduced thickness as this allows them to be mounted in a sash having a normal thickness, in the usual manner. However, from the standpoint of thermal efficiency, such a solution defeats the main purpose of the change because it greatly reduces the insulation expected of triple glazed units. Such "thin" triple glazing is not really very superior to the usual double glazed units.

OBJECTS AND STATEMENT OF THE INVENTION

A main object of the present invention is to provide a window, having a thick glazed unit mounted in a normal sash.

Another object of this invention is to provide a retaining device for mounting a thick sealed glazed unit in a window sash or a door frame, which device can be easily manufactured and used.

In accordance with this invention, these objects are achieved by using a jaw inserted between the glazed

unit and the sash of the window pane and also a retaining moulding progressively engageable in a one-way direction in the jaw, to immobilize the glazed unit in the sash.

Thus, the system herein describes a multiple sealed glazed unit mounted to a wooden sash that includes an L-shaped seat of a standard depth. This seat is edged laterally by a peripheral shoulder against which bears the glazed unit and the thickness of the latter is greater or substantially equal as compared to the depth of the seat. A retaining device comprising a peripheral base member adapted to be engaged to the sash and inserted between the glazed unit and the sash and a removable peripheral retaining moulding adapted to be engaged in the base member and pressing the glazed unit against the shoulder to hold the glazed unit in the sash. This retaining moulding is adapted to be engaged in the base member by means of a ratchet-stop allowing a progressive notch engagement of the retaining moulding but preventing any backward motion or unwanted withdrawal.

Other possible applications of the present invention will be obvious from the detailed description of a preferred embodiment of the invention which will be given hereinafter by referring to the accompanying drawings in which:

BRIEF DESCRIPTION OF THE DRAWINGS

FIG. 1 is a horizontal sectional view of a portion of a leaf of a window displaying one of the stiles of the sash and a portion of the triple glazed unit; and

FIG. 2 is a sectional view of the retaining device according to the present invention.

DESCRIPTION OF A PREFERRED EMBODIMENT

The portion of the window illustrated in FIG. 1, generally indicated by the reference 10, is a horizontal sectional view illustrating a stile of a sash of a sealed triple glazed window. The window comprises a wooded sash 12, a multiple glazed sealed unit 16 and a retaining device 18 holding the glazed unit 16 to the sash 12. The latter comprises an L-shaped seat 20 receiving the glazed unit 16 therein and including a shoulder portion or peripheral stop 22 against which the glazed unit 16 rests. This shoulder portion 22 is integral with the sash 12. The sash 12 has a standard thickness, for example, approximately 45 mm; the depth of the seat 20 is about equal or smaller as compared to the thickness of the glazed unit 16 (approximately 38 mm). Sashes of this kind are commonly used on the North American market.

The retaining device 18 is constituted by a peripheral base member 24, the preferably an extrusion of plastic material, following the perimeter of the glazed unit 16, and by a peripheral retaining moulding 26, also an extrusion of plastic material. The retaining device 18 is engaged to the base member 24 and serves to press the glazed unit against the shoulder 22 to hold it in the sash 12.

Referring to FIG. 2, which illustrates a preferred embodiment of the retaining device according to the invention, the base member 24 comprises a jaw 30, having on the inner side of one of its opposite branches, a set of tiny teeth 40. The base member 24 is supported to the sash 12 by means of a longitudinal flange 32 penetrating a groove 34 (see FIG. 1) made on the rabbet of

the sash 12. The flange 32 is secured in the groove 34 by means of resilient fins 33 pressing against the wall of the groove 34. Further, a hook 49 mounted on the extremity of the flange 32 stabilizes the base member 24. The latter also comprises a rib 35 pressing on the edge of the sash 12, which swings the jaw 30 and the retaining moulding 26 against the glazed unit 16 increasing pressure on the latter.

The retaining moulding 26 comprises a tongue 36 carrying at its extremity a pawl 38 engaging the back of teeth 40 of the jaw 30. At the other extremity are mounted two diverging wings 42 holding an ornamental moulding 44. When the tongue 36 penetrates the jaw 30, the pawl 38 engages the back of teeth 40 of the jaw 30 to form a progressive notch ratchet-stop. Thus, when the retaining moulding 26 is engaged in the jaw 30, the glazed unit 16 is clamped in the sash 12 between the shoulder portion 22 and the retaining moulding 26. The presence of a plurality of teeth 40, very fine and slightly spaced, allows an engagement at different positions of the retaining moulding 26 in the jaw 30. This system can receive and accommodate glazed units having different thicknesses. It further allows to hold the glazed unit with more or less pressure, by tightening the weather stripping 50 against the internal glass pane.

For the installation of the glazed unit 16, a peripheral rubber band 46 may be installed in seat 20 to provide additional engagement to the glazed unit 16.

The imperviousness between the glazed unit 16 and the sash 12 is achieved by using a plastic sealer 51 and a rubber stripping 50.

In a preferred embodiment of the invention, the sash has a thickness of 35 mm and the glazed unit has a thickness of 38 mm. In another embodiment, the sash has a thickness of 45 mm.

The invention will now be defined in the following claims and it is well understood that the preferred embodiment described above may be modified in its secondary aspects without altering the gist of the invention.

What is claimed is:

1. A device for holding a multiple glazed sealed unit in a wooded sash having a rabbet, said glazed unit having a given uniform thickness, said sash defining an L-shaped seat receiving said glazed unit therein, said seat having a given uniform depth and being edged laterally by a shoulder portion which determines the depth of said seat and against which bears said glazed unit, the thickness of said glazed unit being greater or no less than the depth of said seat, said device comprising:

- a peripheral base member adapted to be inserted between said glazed unit and said sash, said peripheral base member being retained on said sash;
- a removable peripheral retaining moulding, adapted to be engaged in the peripheral base member and pressing the glazed unit against the shoulder of the seat to hold said glazed unit in said sash, said peripheral retaining moulding being adapted to be engaged in said peripheral base member by means of a ratchet-stop allowing a progressive notch engagement of said peripheral retaining moulding in said peripheral base member but prevent unwanted withdrawal of said peripheral retaining moulding relatively to said peripheral base member;
- said peripheral base member being constituted by a jaw having two branches, one of which comprises on its inner side a set of teeth, said peripheral retaining moulding comprising a tongue substantially

perpendicular to the plane of said sash, said tongue penetrating said base member and comprising, at one end, a pawl engaging the backside of said teeth in order to form said ratchet-stop;

said peripheral base member being retained on said sash by means of a longitudinal flange extending substantially at right angles relative to said base member, said flange penetrating and being held in a peripheral groove formed in said rabbet of said sash, said peripheral groove being spaced from said shoulder portion of said sash a predetermined distance.

2. Device as defined in claim 1, wherein the peripheral base and the retaining moulding are made from a suitable plastic material and have each a constant cross-section.

3. Device as defined in claim 2, comprising a rubber fin on each side of the longitudinal flange of said peripheral base member.

4. The combination of a retaining device, a multiple sealed glazed unit and a wooded sash on which said retaining device holds the glazed unit, said glazed unit being a given thickness, said sash defining an L-shaped seat receiving said glazed unit therein, said seat having a given uniform depth and being laterally edged by a peripheral shoulder portion against which bears said glazed unit, and the thickness of said glazed unit being greater than or substantially equal to the depth of said seat, said retaining device comprising:

a peripheral base inserted between the glazed unit and the sash, and retained to the latter;

a removable peripheral retaining moulding, engaged in said peripheral base member and pressing the glazed unit in the sash, said peripheral retaining moulding being engaged in said peripheral base member by means of a ratchet stop allowing a progressive notch engagement of said peripheral retaining moulding in the peripheral base member but preventing unwanted withdrawal of said peripheral retaining moulding relatively to the peripheral base member;

said peripheral base member constituted by a jaw having two branches, one of which comprises on its inner side a set of teeth, said peripheral retaining moulding comprising a tongue substantially perpendicular to the plane of said sash, said tongue penetrating said base member and comprising, at one end, a pawl engaging the backside of said teeth in order to form said ratchet stop,

said peripheral base member being retained on said sash by means of a longitudinal flange extending substantially at right angles relative to the base member, said sash including a rabbet, said flange penetrating and being held in a peripheral groove formed in said rabbet of said sash, said peripheral groove being spaced from said shoulder portion a predetermined distance;

a first weather-strip installed between said shoulder portion and said glazed unit; and

a second weather-strip installed between said peripheral retaining moulding and said glazed unit.

5. The combination as defined in claim 4, wherein said first weather-strip is a plastic sealer and said second weather-strip is a strip of elastic material, said peripheral base member and said peripheral retaining moulding being made from a suitable plastic material and having each a constant cross-section.

6. A casing window comprising:

a wooded jamb lining;
 at least one panel pivoting in said jamb lining and including:
 (a) a wooded sash including a rabbet carrying a triple glazed sealed unit held in said sash by means of a retaining device, said glazed unit having a given thickness, and said sash defining an L-shaped seat receiving said glazed unit, which seat has a uniform depth and is edged laterally by a peripheral shoulder portion against which bears said glazed unit, the thickness of said glazed unit being greater than or substantially equal to the depth of said seat, said device comprising:
 (i) a peripheral base member adapted to be inserted between said glazed unit and said sash, said peripheral base member being retained on said sash;
 (ii) a removable peripheral retaining moulding, adapted to be engaged in the peripheral base member and pressing the glazed unit against the shoulder portion of the seat to hold said glazed unit in said sash, said peripheral retaining moulding being adapted to be engaged in said peripheral base member by means of a ratchet-stop allowing a progressive notch engagement of said peripheral retaining

25

30

35

40

45

50

55

60

65

moulding in said peripheral base member but preventing unwanted withdrawal of said peripheral retaining moulding relatively to said peripheral base member;
 said peripheral base member constituted by a jaw having two branches, one of which comprises on its inner side a set of teeth, said peripheral retaining moulding comprising a tongue substantially perpendicular to the plane of said sash, said tongue penetrating said base member and comprising, at one end, a pawl engaging the backside of said teeth in order to form said ratchet stop,
 said peripheral base member being retained on said sash by means of a longitudinal flange extending substantially at right angles relative to the base member, said flange penetrating and being held in a peripheral groove formed in said rabbet of said sash, said peripheral groove being spaced from said shoulder portion a predetermined distance;
 (b) imperviousness means mounted between said glazed unit and said sash preventing air infiltration through said panel.

* * * * *