

[54] IONTOPHORETIC ELECTRODE STRUCTURE

[75] Inventors: Stephen C. Jacobsen, Salt Lake City; Richard D. Luntz, Murray; Barry K. Hanover, Salt Lake City, all of Utah

[73] Assignee: Motion Control, Inc., Salt Lake City, Utah

[21] Appl. No.: 319,074

[22] Filed: Nov. 6, 1981

[51] Int. Cl.³ A61N 1/30

[52] U.S. Cl. 604/20; 128/803

[58] Field of Search 128/639-641, 128/644, 207.21, 798, 802, 803, 325, 260, 274; 604/20

[56] References Cited

U.S. PATENT DOCUMENTS

3,187,745	6/1965	Baum et al.	128/639
3,730,186	5/1973	Edmunds, Jr. et al.	128/325
3,750,094	7/1973	Zenkich	128/641
3,805,769	4/1974	Sessions	128/641
4,063,555	12/1977	Ulinder	128/274 X
4,137,909	2/1979	Hix	128/641
4,166,457	9/1979	Jacobsen et al.	128/207.21
4,250,878	2/1981	Jacobsen et al.	604/20
4,304,453	12/1981	Grunweld	128/639 X

FOREIGN PATENT DOCUMENTS

648203 2/1979 U.S.S.R. 128/639

Primary Examiner—Lee S. Cohen

Attorney, Agent, or Firm—Thorpe, North & Western

[57] ABSTRACT

An iontophoretic bioelectrode includes an enclosure having a bottom wall formed of a membrane through which ions may migrate when subjected to an electric field, and an upper wall joined to the bottom wall to define an interior compartment for holding an ion-containing solution. An electrode in the form of the male portion of a conventional clothing snap is mounted to the enclosure to communicate electrically with solution contained in the interior compartment. A needle receiving element is mounted in the upper wall of the enclosure. This element is in the form of a section of conduit having a receiving end, which is directed upwardly, and a blocking end which includes a platform for preventing a needle inserted into the receiving end from passing all the way through the conduit. A resilient plug is disposed in the receiving end of the conduit to prevent solution from escaping from the interior compartment. The plug is formed of a material through which a needle may be inserted but which, when the needle is retracted, closes about the opening made by the needle to prevent the escape of solution.

12 Claims, 4 Drawing Figures

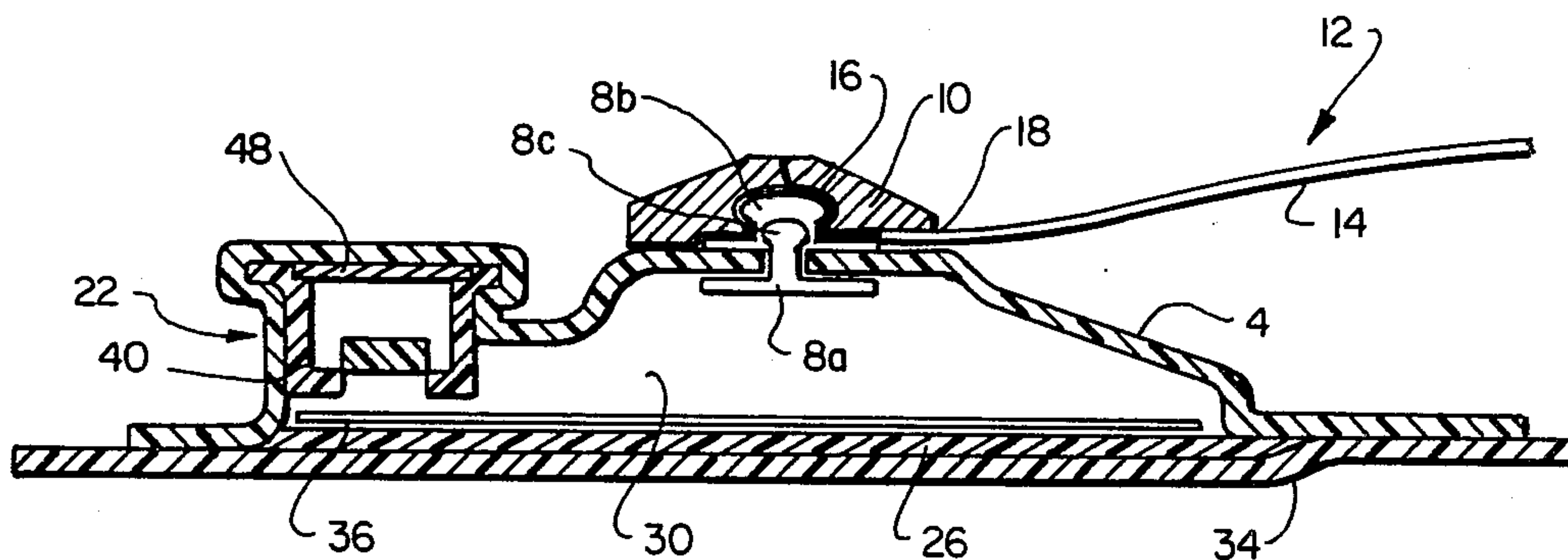

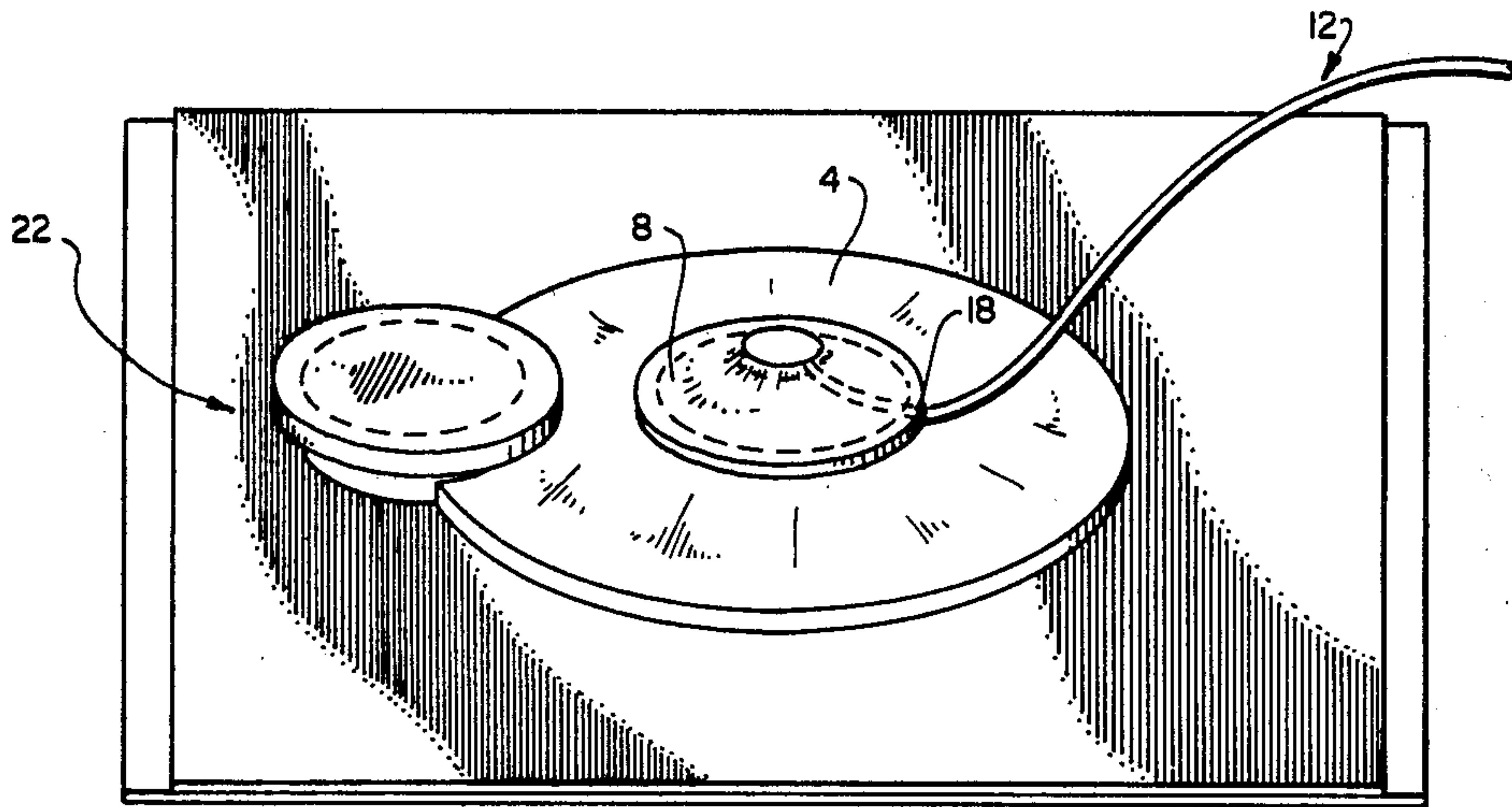

Fig. 1

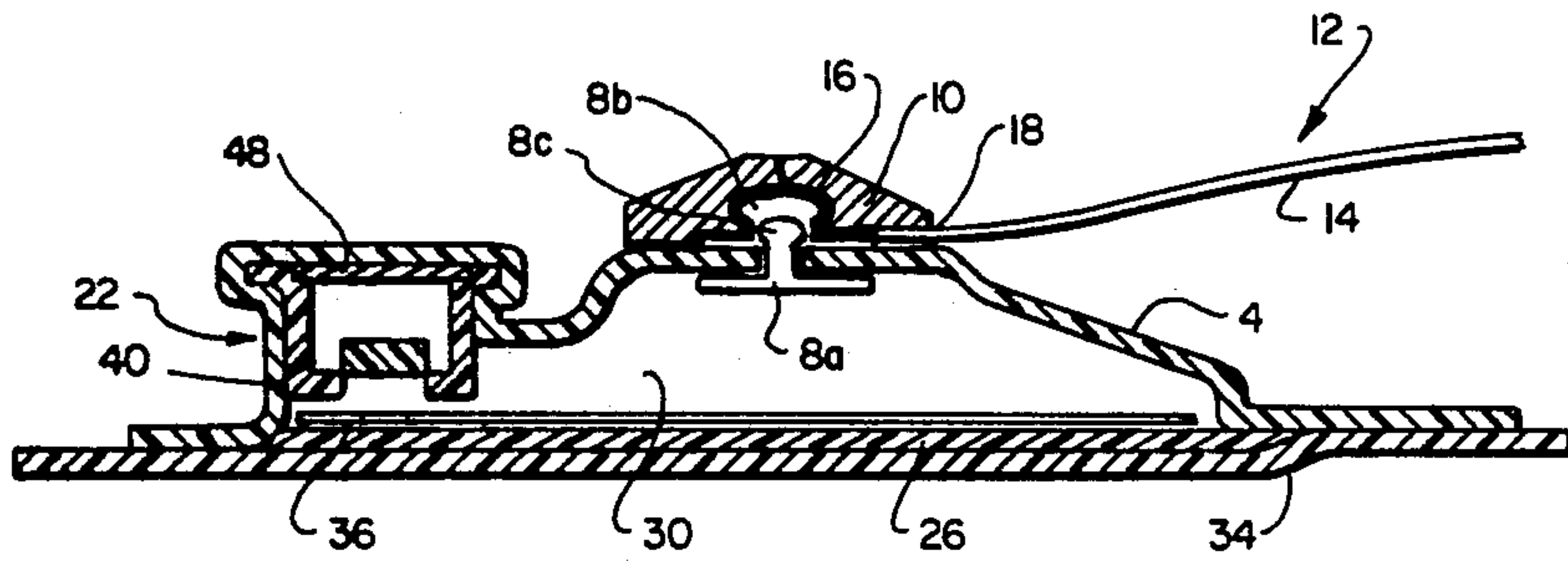

Fig. 2

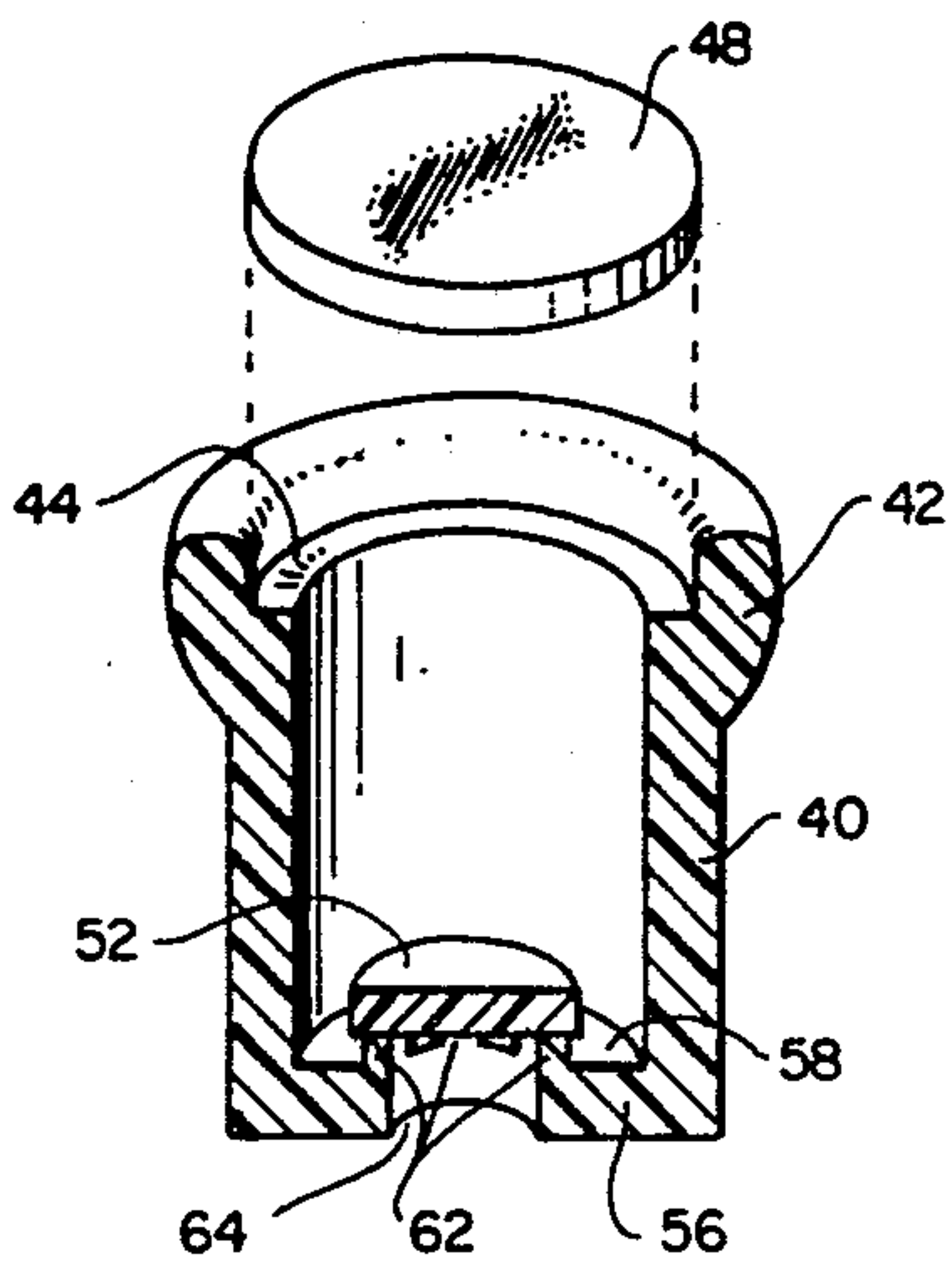

Fig. 3

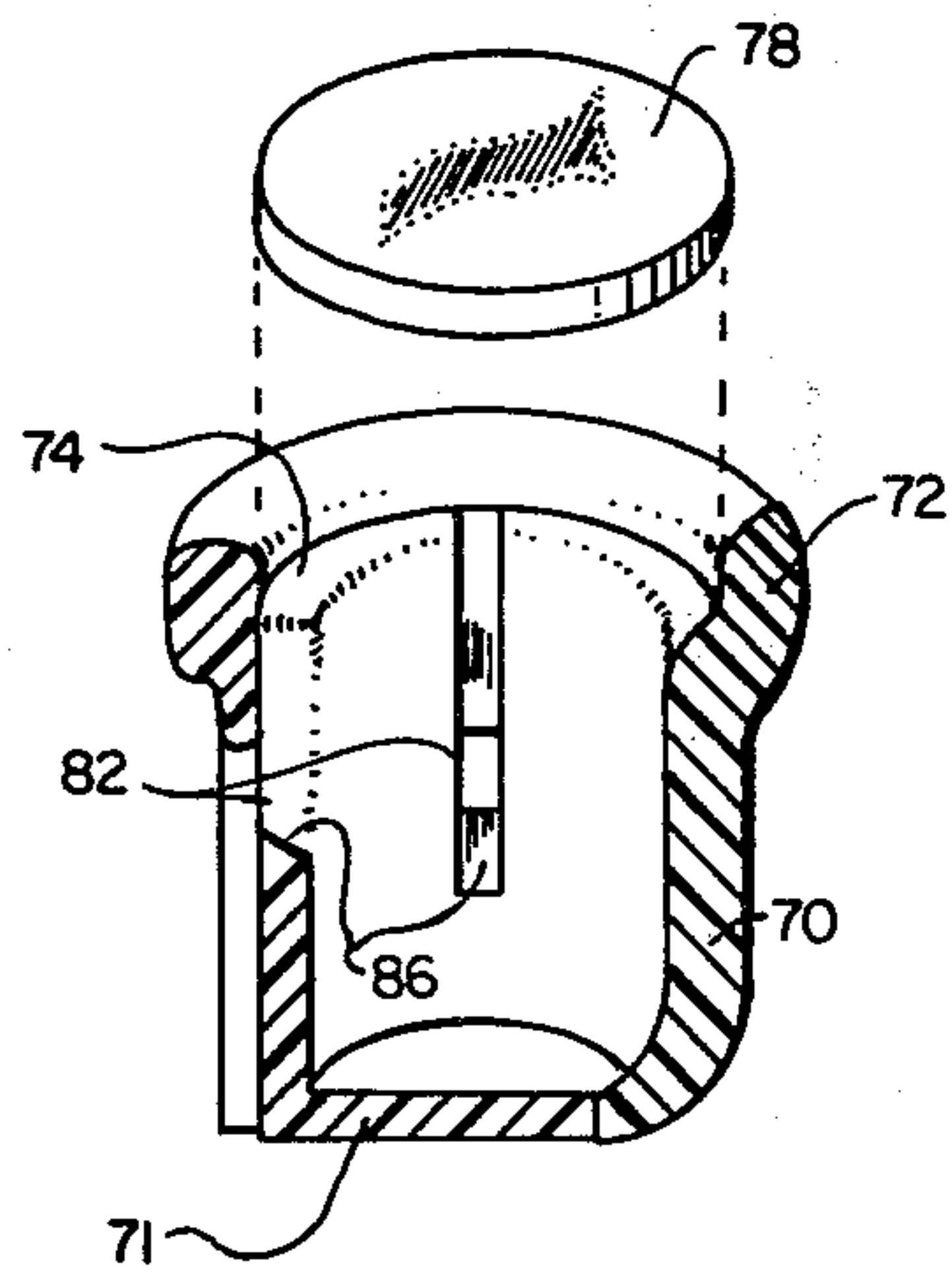

Fig. 4

IONTOPHORETIC ELECTRODE STRUCTURE

BACKGROUND OF THE INVENTION

This invention relates to a new and improved iontophoretic bioelectrode structure which is simple in design, and to a method of manufacturing the structure.

Iontophoresis is a technique of delivering ions into a person's skin or tissue by placing a solution or other medium containing the ions in contact with the skin, and applying electric current to the medium. The solution or medium containing the ions is typically carried by a first bioelectrode pouch or receptacle. Ions are caused to migrate from the ion carrying medium through the skin or tissue by the application of the electric current to the medium, and by placement against the skin and of a second bioelectrode within proximity of the first bioelectrode and the application of current of opposite polarity to the second bioelectrode. This technique has been discussed in a number of prior art patents including U.S. Pat. No. 4,141,359 and 4,166,457. Examples of bioelectrodes which are generally useful for making electrical contact with the skin are described in U.S. Pat. Nos. 3,862,633, 3,945,384 and 3,973,557.

There have been several bioelectrode proposals for carrying the ion solution or medium and placing it in proximity with the skin including provision of a receptacle with a wettable barrier on one side thereof. The wettable barrier or wall is covered until time of use and then uncovered for placement against the skin. Then, upon application of the electrical current, the ions migrate through the wall into the skin.

Another proposed arrangement involves the use of a receptacle having a microporous membrane on one side thereof which may be placed in contact with a person's skin. The membrane is selected so that it will not leak prior to use, but will allow migration of ions there-through to the skin upon application of an electric current to the ion-carrying solution. With this arrangement, less care need be given to storage, transport, or use of the receptacle since the ion containing fluid will not leak as it is used.

Still another suggested arrangement involves a bioelectrode structure which includes a holder for holding ions to be delivered, wherein the holder is adapted to inhibit movement of ions in a direction generally parallel to the surface of the skin or tissue while allowing movement toward the skin or tissue. One exemplary configuration of this bioelectrode is to provide the receptacle with a gel material preloaded with ions.

Generally, bioelectrodes heretofore proposed either provide for including the ion-containing solution in the bioelectrode as it is manufactured, or simply providing a structure into which ion-containing solution can later be introduced by the user. In the latter case, typically a special structure is provided on the bioelectrode for receiving a solution applicator, and a special applicator structure is provided for supplying the solution to the bioelectrode. Such special structure is employed, among other things, to enable introduction of solution into the bioelectrode without puncturing it.

SUMMARY OF THE INVENTION

It is an object of the invention to provide a new and improved bioelectrode which is simple in design and easy and inexpensive to manufacture.

It is another object of the invention to provide such a bioelectrode wherein ion-containing solution may be introduced into the electrode using a conventional hypodermic needle.

It is a further object of the invention to provide such a bioelectrode having a structure which minimizes the likelihood of puncture by a solution-introducing needle.

The above and other objects of the invention are realized in a bioelectrode structure. The bioelectrode includes an enclosure having a bottom wall formed of a membrane through which ions may migrate when subjected to an electric field, and an upper wall joined to the bottom wall to define an interior compartment for holding an ion-containing solution. An electrode is mounted to the enclosure to communicate electrically with the interior thereof through the upper wall. A receptacle element is disposed in the enclosure for receiving a needle or similar solution-introducing device and for thereafter transferring the solution to the interior of the enclosure.

One embodiment of the receptacle element is in the form of a conduit open at both ends and having a first end which is directed away from the bottom wall of the enclosure. A blocking element is disposed at the second end of the conduit to prevent the needle inserted into the conduit through the first end from passing through the second end, while also allowing fluid to flow through the conduit and out the second end. A plug is positioned in the first end of the conduit to prevent solution from escaping from the interior compartment of the enclosure but for allowing penetration by a needle.

Another embodiment of the receptacle element is also in the form of a conduit open at one end only, with narrow openings on the sides of the conduit for allowing the flow therethrough of fluid.

BRIEF DESCRIPTION OF THE DRAWINGS

The above and other objects, features and advantages of the invention will become apparent from a consideration of the following detailed description presented in connection with the accompanying drawings in which:

FIG. 1 is a perspective view of a bioelectrode made in accordance with the principles of the present invention;

FIG. 2 is a side, cross sectional view of the bioelectrode of FIG. 1;

FIG. 3 is a perspective, cross-sectional view of one embodiment of the receptacle of the bioelectrode of FIG. 1; and

FIG. 4 is a perspective, cross-sectional view of another embodiment of the receptacle.

DETAILED DESCRIPTION

Referring to FIGS. 1 and 2, there is shown a bioelectrode composed of a generally dome-shaped upper wall 4 which may be made of plastic, polyvinyl chloride, polyurethane, or other material suitable for holding a solution. Attached to the wall 4 to be exposed to the area under the wall is a male element 8 of a conventional metallic snap used on clothing and the like. The element 8 includes a base portion 8a and an upper or nipple portion 8b projecting upwardly from the base portion when the two are snapped together. The base portion 8a includes an upstanding stud 8c which is fitted through an opening in the wall 4 and is received into a receptacle formed in the underneath side of the nipple portion 8b. When snapped together as shown in FIG. 2, the two portions 8a and 8b are held in place in the wall 4 so that

the base portion **8b** is exposed to a compartment **30**, to be discussed momentarily. A dome-shaped cover **10** is provided to fit over the nipple **8b**, and disposed to extend between the cover and the nipple is a wire conductor **12**, one end of which has insulation material **14** removed to expose bare wire **16**. The conductor **12** exists from under the cover **10** through a slot **18** in the cover **10**. The exposed wire **16** of the conductor **12** is disposed between the nipple **8b** and the cover **10** to make electrical contact with the nipple. The cover **10** may be made of plastic or other resilient material.

The other end of the conductor **12** would be connected to an electrical potential source (not shown).

Also attached to the underneath side of the upper wall **4** is a receptacle structure **22** through which ion-containing solution is introduced into the bioelectrode of FIGS. 1 and 2. This structure will be described momentarily.

The bioelectrode of FIGS. 1 and 2 also includes a bottom wall **26** whose perimeter is joined to the upper wall **4** to define an interior compartment **30** for holding an ion containing solution. The bottom wall **26** comprises a membrane which will allow the migration of ions therethrough when an ion-containing solution in the compartment **30** is subjected to an electric field (such as when an electrical potential is applied to the conductor **12**). An exemplary material for use as the bottom wall **26** is a polycarbonate semipermeable membrane. The material selected for the bottom wall **26** may differ for different ion-containing solutions to be used in the bioelectrode. For example, polycarbonate materials of differing pore sizes, other hydrophilic or hydrophobic materials such as foams made from acrylic copolymers, polyvinyl chloride copolymers or cellulose might also be used depending upon the type of solution to be used.

A protective cover **34** is secured by a releasable adhesive to the bottom wall **26** and to the bottom surface of a portion of the upper wall **4** to prevent damage or contamination to the bottom wall. This material could be simple plastic, treated paper, or other suitable covering material. A piece of filter paper **36** is placed in the compartment **30** above the bottom wall **26** to protect the wall **26** during production and shipping.

As indicated earlier, the receptacle **22** is positioned in the bioelectrode to allow introduction of ion-containing solution into the interior compartment **30**. One embodiment of the receptacle **22** (shown in FIGS. 2 and 3) includes a generally annular conduit **40**, an upper end of which is formed with an outwardly and upwardly flaring lip **42**. The lip **42** is formed to define a seat **44** on which is placed a plug **48**. The plug **48** is made of a resilient material through which a hypodermic needle may be inserted but which will close about the opening made by the needle when the needle is removed. The function of the plug **48** is to prevent the leaking of solution through the conduit **40** from the interior compartment **30**. An exemplary material for the plug **48** is natural rubber, silicone rubber, butyl rubber, etc.

The bottom end of the conduit **40**, like the upper end thereof, is also open to allow transmission therethrough of an ion-containing solution. Formed in the bottom end is a blocking structure for preventing a hypodermic needle inserted into the conduit through the upper end from passing all the way through the conduit and out of the bottom end. The blocking structure includes a platform **52** disposed within the conduit, with the perimeter thereof being spaced from the interior wall of the con-

duit to allow solution to flow thereby. A circumferential lip **56** projects inwardly from the bottom of the conduit **40** to define a ledge **58** positioned below the periphery of the platform **52**. Legs **62** project upwardly from the lip **56** to contact and support the bottom of the platform **52**. The legs **62** are spaced about an opening **64** defined by the inward termination of the lip **56**.

As can best be seen from FIG. 3, solution is introduced through the conduit **40** by inserting a hypodermic needle into the plug **48** and then discharging the solution through the hypodermic needle so that it flows past the perimeter of the platform **52**, through the spaces between the legs **62**, and out the opening **64** to the interior compartment **30** of the bioelectrode (FIG. 2). The hypodermic needle is prevented from being inserted all the way through the conduit **40** by the platform **52** and the ledge **58**. If the hypodermic needle slips past the platform, then it will contact and be stopped by the ledge **58**.

An alternative embodiment of the receptacle **22** of FIG. 1 is shown in FIG. 4. This embodiment includes an annular conduit or vessel **70**, the bottom end of which is closed with a bottom wall **71**, and the upper end of which is open and is formed with an outwardly and upwardly flaring lip **72**. The lip **72** defines a seat **74** on which is placed a plug **78**, similar to the embodiment of FIG. 3. This plug is made of a resilient material through which a hypodermic needle may be inserted, and which will close about the needle-created opening when the needle is removed. Formed in the side walls of the vessel **70** are a plurality of openings **82** which are moderately narrower than the diameter of a hypodermic needle. The openings **82** are formed so that each opening or window sill **86** slopes downwardly and inwardly to deflect to the interior vessel any needle which may contact the sill. This structure, as with that of FIG. 3, prevents a needle inserted therein from passing all the way through the structure since the needle will contact and be stopped by the bottom wall **71**.

It should be understood that there may be a variety of blocking structure configurations to prevent a hypodermic needle from being inserted all the way through the receptacle **22**. It is desirable, of course, to provide such a blocking feature so that the hypodermic needle does not puncture other parts of the bioelectrode.

Referring again to FIG. 2, the receptacle **22** is disposed in the upper wall **4** of the bioelectrode so that the bottom of the receptacle is out of contact with the bottom wall **26**. By being spaced above the bottom wall **26**, the solution introduced into the bioelectrode may more readily flow from the receptacle **22** to fill the interior compartment **30**. If the receptacle **22** were positioned just above or in contact with the bottom wall **26**, then the likelihood of a concentration of the solution at that site would be increased and this, in turn, might increase the chance of burning of the skin or tissue of the person when the bioelectrode were placed in use. This is because the solution would be concentrated at the location of the receptacle **22**.

The structure described in connection with FIGS. 1-4 is simple in construction and thus may be readily manufactured. An exemplary method of manufacturing the bioelectrode includes the steps of placing a plug **48** and conduit **40** onto a mold whose upper surface is formed into a dome shape similar to the shape of the upper wall **4**, and then placing a section of plastic polyvinyl chloride, polyurethane, etc., material over the mold, plug and conduit. The material is then vacuum

formed over the mold, plug and conduit to the shape of the mold. When removed from the mold, the plug and conduit remain attached to the underneath side of what will be the upper wall of the bioelectrode. The base portion 8a and nipple portion 8b of the snap 8 are then attached to the upper wall 4. The exposed part 16 of the conductor 12 is then positioned over the nipple 8b and the cover 10 is placed over the nipple and held in place with a suitable adhesive. The filter paper 36 is placed in the compartment 30 and the bottom wall 26 is attached at or near its periphery to the upper wall 4. The protective cover 34 is then put in place in contact with the bottom wall 26 and a portion of the upper wall 4.

It is to be understood that the above-described arrangements are only illustrative of the application of the principles of the present invention. Numerous modifications and alternative arrangements may be devised by those skilled in the art without departing from the spirit and scope of the present invention and the appended claims are intended to cover such modifications and arrangements.

What is claimed is:

1. A bioelectrode for use in the iontophoretic delivery of ions into the skin or tissue of a person comprising an enclosure having a bottom wall formed of a membrane through which ions may migrate when subjected to an electric field and an upper wall joined to the bottom wall to define an interior compartment for holding an ion-containing solution, an electrode mounted to the enclosure to communicate electrically with the interior compartment of the enclosure through the upper wall, and receptacle means disposed in the enclosure for receiving solution into the enclosure, said receptacle means having a top and a bottom and being attached to said upper wall so that the bottom of the receptacle means is elevated above and out of contact with the bottom wall, said receptacle means including
 - a conduit open at a first end, defining said top, which is directed away from the bottom wall,
 - one or more openings located in the conduit to allow solution which is introduced into the conduit to flow therefrom,
 - a blocking element disposed at a second end defining said bottom of the conduit to prevent a needle inserted into the conduit through the first end from passing through the second end, and
 - a plug means disposed in the first end to prevent solution from escaping from the interior of the enclosure, said plug means being made of a resilient material through which a needle may be inserted

and which, when the needle is retracted, closes about the opening made by the needle.

2. A bioelectrode as in claim 1 wherein said receptacle means is attached to the interior surface of the upper wall.

3. A bioelectrode as in claim 1 wherein the upper wall is constructed generally in a dome shape.

4. A bioelectrode as in claim 3 wherein the upper wall is made of polyvinyl chloride or polyurethane.

5. A bioelectrode as in claim 1 wherein said blocking element comprises

a platform disposed within the conduit with at least a portion of the perimeter of the platform being spaced from the interior wall of the conduit, and legs extending between the conduit wall and the platform to support the platform, said one or more openings being located between adjacent legs.

6. A bioelectrode as in claim 5 wherein said blocking element further comprises a lip circumferentially positioned on the interior wall of the conduit and projecting inwardly from the wall toward a locus generally below the platform to thereby define a space between the lip and the platform.

7. A bioelectrode as in claim 1 wherein said one or more openings are located in the sides of the conduit, and wherein said blocking element comprises a bottom wall disposed at and closing the second end of the conduit.

8. A bioelectrode as in claim 7 wherein said one or more openings are moderately narrower in width than a conventional hypodermic needle.

9. A bioelectrode as in claim 7 wherein said receptacle means further includes one or more sills located below said one or more openings, each of said sills defining a surface which slopes downwardly and inwardly from the respective opening.

10. A bioelectrode as in claim 1 wherein said plug means is made of a resilient rubber.

11. A bioelectrode as in claim 1 wherein said electrode comprises

a metallic snap element having a base portion which is exposed to the compartment and an upwardly projecting nipple which projects above the upper wall of the enclosure, said base portion and nipple being in electrical communication, and an electrical conductor, one end of which is electrically coupled to the nipple.

12. A bioelectrode as in claim 11 further comprising a cover which fits over the nipple to maintain the end of the conductor in contact with the nipple.

* * * * *

55

60

65