

[54] **ELECTROPHOTOSENSITIVE MATERIALS FOR MIGRATION IMAGING PROCESSES**

[75] Inventors: **Frank G. Webster**, Rochester; **Michael T. Regan**, Fairport; **Louis J. Rossi**, Rochester, all of N.Y.

[73] Assignee: **Eastman Kodak Company**, Rochester, N.Y.

[21] Appl. No.: **202,406**

[22] Filed: **Oct. 31, 1980**

Related U.S. Application Data

[60] Division of Ser. No. 12,172, Dec. 14, 1979, Pat. No. 4,272,595, which is a continuation-in-part of Ser. No. 899,186, Apr. 24, 1978, abandoned, which is a continuation-in-part of Ser. No. 818,697, Jul. 25, 1977, abandoned.

[51] Int. Cl.³ **G03G 5/06; G03G 17/04**

[52] U.S. Cl. **430/17; 430/72; 430/74; 106/23**

[58] Field of Search **430/17, 32, 37, 72, 430/74; 106/23**

References Cited

U.S. PATENT DOCUMENTS

2,538,009	1/1951	keges et al.	430/522
2,860,981	11/1958	Jones	430/572
2,860,982	11/1958	Jones	430/572
3,158,475	11/1964	Cassiers et al.	430/97
3,246,983	4/1966	Sus et al.	430/97
3,331,687	7/1967	Kosche	430/72
3,384,488	1/1968	Tulagin et al.	430/32
3,546,085	12/1970	Weinburger	430/37
3,647,433	3/1972	Contois	430/82
3,677,752	7/1972	Looker et al.	430/74
4,046,563	9/1977	Pearson	430/72

Primary Examiner—Roland E. Martin, Jr.

Attorney, Agent, or Firm—Torger N. Dahl

[57] **ABSTRACT**

Electrophotosensitive materials having the structure

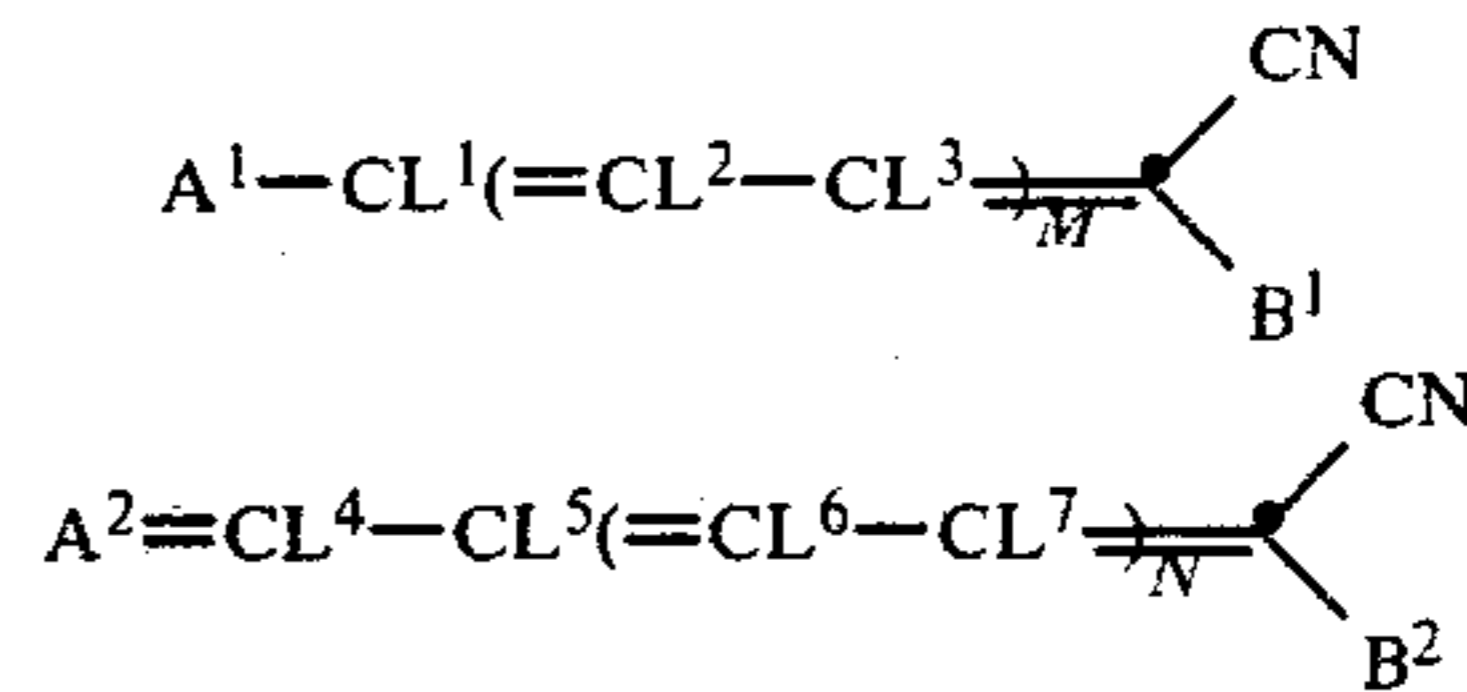

wherein:

M and N may be zero, one or two;

L¹, L², L³, L⁴, L⁵, L⁶, and L⁷ may be cyano, hydrogen, substituted or unsubstituted alkyl, alkoxy, aralkyl, aryl or heterocycyl and in addition any two of L¹, L² and L³ and any two of L⁴, L⁵, L⁶ and L⁷ may together represent the elements needed to complete a carbocyclic or heterocyclic ring having from 5-12 carbon atoms;

A¹ may be the same as A² and in addition may represent a substituted or unsubstituted aryl group;

A² represents a basic substituted or unsubstituted heterocyclic nucleus; and

B¹ and B² represent cyano, cyanoaryl, carboxy, alkoxycarbonyl, aryloxycarbonyl, alkylsulfonyl, acyl, arylcarbonyl, heteroyl groups such as benzofuroyl, nitro, nitro substituted aryl, sulfonyl, fluorosulfonyl, trifluoromethylsulfonyl, carbamoyl, arylcarbamoyl, and alkylcarbamoyl or

B² may be combined with =CL⁴-CL⁵= or =CL⁶-CL⁷= to provide sufficient atoms to form a substituted pyridine nucleus.

5 Claims, 1 Drawing Figure

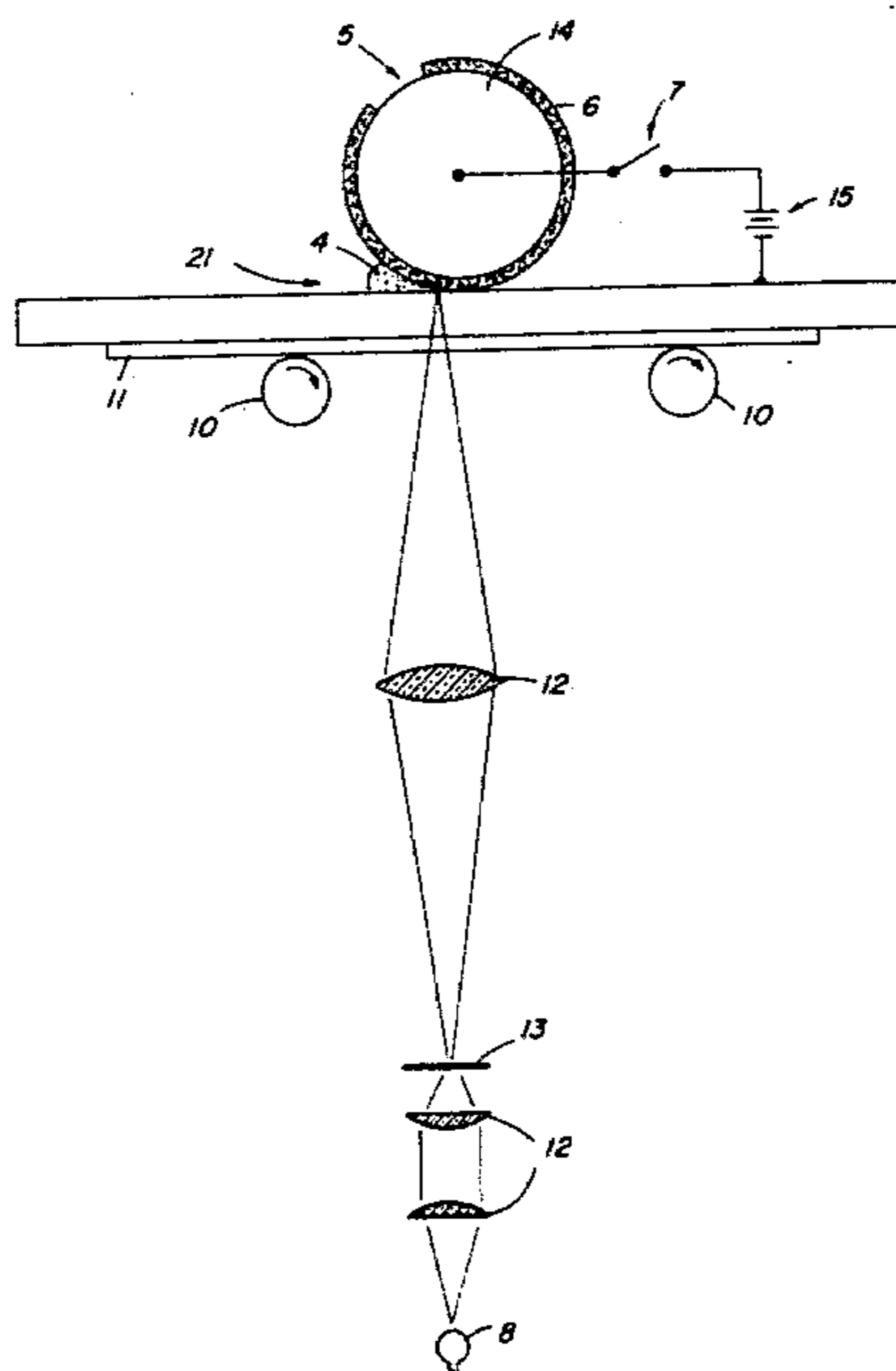
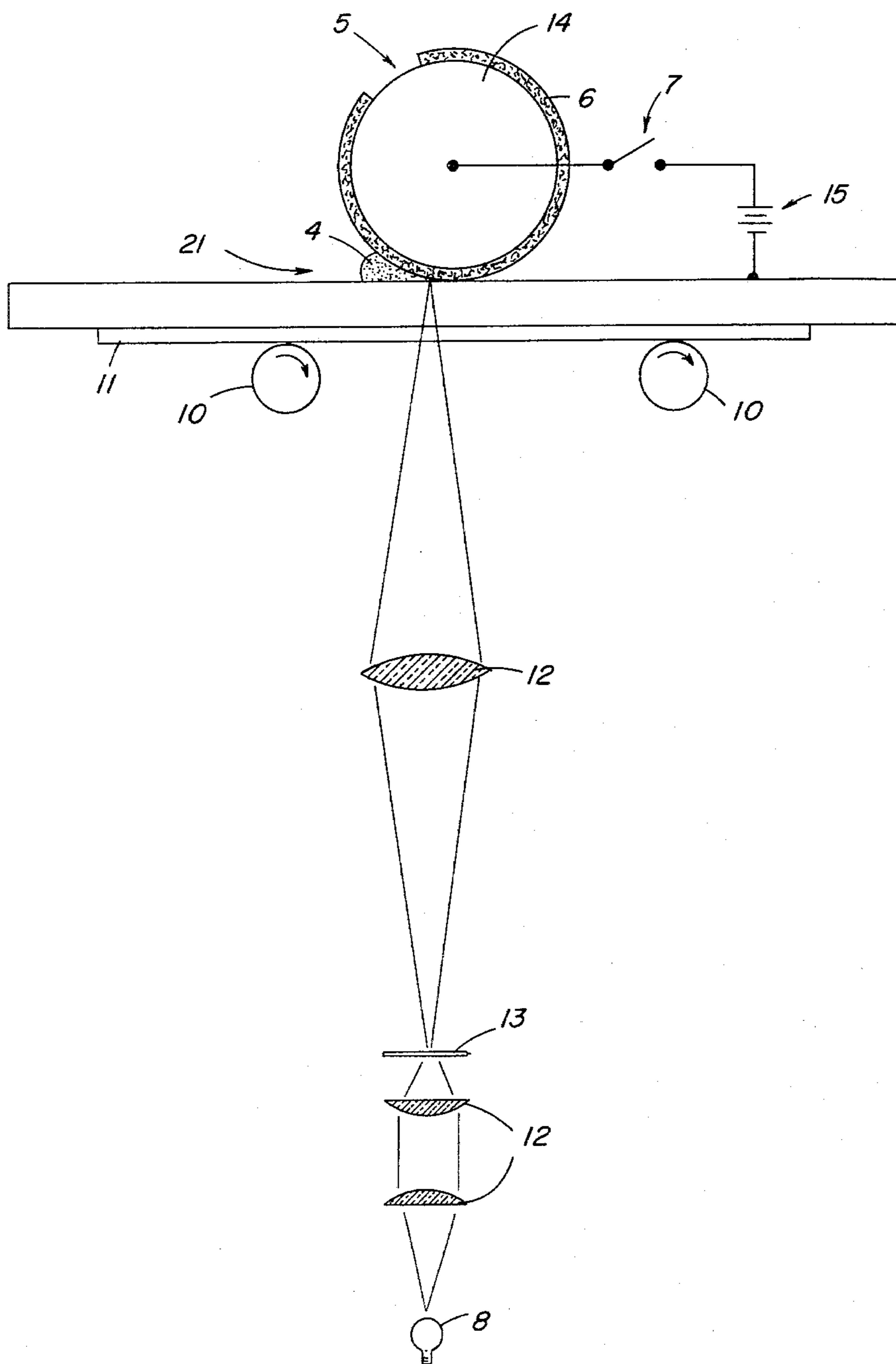

FIG. 1



ELECTROPHOTOSENSITIVE MATERIALS FOR MIGRATION IMAGING PROCESSES

This a Rule 60 Divisional application of Ser. No. 012,172 filed Feb. 14, 1979 in the U.S. Pat. No. 4,272,595; which is a Continuation-In-Part of U.S. Ser. No. 899,186 filed Apr. 24, 1978, now abandoned; which is a Continuation-In-Part of U.S. Ser. No. 818,697 filed July 25, 1977, now abandoned.

FIELD OF THE INVENTION

This invention relates to electrophoretic migration imaging processes and, in particular, to the use of certain novel photosensitive pigment materials in such processes.

BACKGROUND OF THE INVENTION

In the past, there has been extensive description in the patent and other technical literature of electrophoretic migration imaging processes. For example, a description of such processes may be found in U.S. Pat. No. 2,758,939 by Sugarman issued Aug. 14, 1956; No. 2,940,847, No. 3,100,426, No. 3,140,175 and No. 3,143,508, all by Kaprelian; No. 3,384,565, No. 3,384,488 and No. 3,615,558, all by Tulagin et al., No. 3,384,566 by Clark; and No. 3,383,993 by Yeh. In addition to the foregoing patent literature directed to conventional photoelectrophoretic migration imaging processes, another type of electrophoretic migration imaging process which advantageously provides for image reversal is described in Groner, U.S. Pat. No. 3,976,485 issued Aug. 24, 1976. This latter process has been termed photoimmobilized electrophoretic recording or PIER.

In general, each of the foregoing electrophoretic migration imaging processes typically employs a layer of electrostatic charge-bearing photoconductive particles, i.e., electrically photosensitive particles, positioned between two spaced electrodes, one of which may be transparent. To achieve image formation in these processes, the charge-bearing photosensitive particles positioned between the two spaced electrodes, as described above, are subjected to the influence of an electric field and exposed to activating radiation. As a result, the charge-bearing electrically photosensitive particles are caused to migrate electrophoretically to the surface of one or the other of the spaced electrodes, and one obtains an image pattern on the surface of these electrodes. Typically, a negative image is formed on one electrode, and a positive image is formed on the opposite electrode. Image discrimination occurs in the various electrophoretic migration imaging processes as a result of a net change in charge polarity of either the exposed electrically photosensitive particles (in the case of conventional electrophoretic migration imaging) or the unexposed electrically photosensitive particles (in the case of the electrophoretic migration imaging process described in the above-noted Groner patent application) so that the image formed on one electrode surface is composed ideally of electrically photosensitive particles of one charge polarity, either negative or positive polarity, and the image formed on the opposite polarity electrode surface is composed ideally of electrically photosensitive particles having the opposite charge polarity, either positive or negative respectively.

In any case, regardless of the particular electrophoretic migration imaging process employed, it is apparent

that an essential component of any such process is the electrically photosensitive particles. And, of course, to obtain an easy-to-read, visible image it is important that these electrically photosensitive particles be colored, as well as electrically photosensitive. Accordingly, as is apparent from the technical literature regarding electrophoretic migration imaging processes, work has been carried on in the past and is continuing to find particles which possess both useful levels of electrical photosensitivity and which exhibit good colorant properties. Thus, for example, various types of electrically photosensitive materials are disclosed for use in electrophoretic migration imaging processes, for example, in U.S. Pat. No. 2,758,939 by Sugarman, No. 2,940,847 by Kaprelian, and No. 3,384,488 and No. 3,615,558 by Tulagin et al., noted hereinabove.

In large part, the art, to date, has generally selected useful electrically photosensitive or photoconductive pigment materials for electrophoretic migration imaging from known classes of photoconductive materials which may be employed in conventional photoconductive elements, e.g., photoconductive plates, drums, or webs used in electrophotographic office-copier devices. For example, both Sugarman and Kaprelian in the above-referenced patents state that electrically photosensitive materials useful in electrophoretic migration imaging processes may be selected from known classes of photoconductive materials. Also, the phthalocyanine pigments described as a useful electrically photosensitive material for electrophoretic imaging processes in U.S. Patent 3,615,558 by Tulagin et al., have long been known to exhibit useful photoconductive properties.

SUMMARY OF THE INVENTION

The present invention provides a group of materials which are useful in electrophoretic migration imaging dispersions, images and processes. To the best of our knowledge, none of these materials have been previously identified as photoconductors. The materials are relatively insoluble in imaging dispersions but are unexpectedly soluble in certain polymer coated image receiving elements. This solubility in the polymer coatings of image receiving elements results in images having excellent color saturation, density and resolution.

Useful materials have one of the following structures:

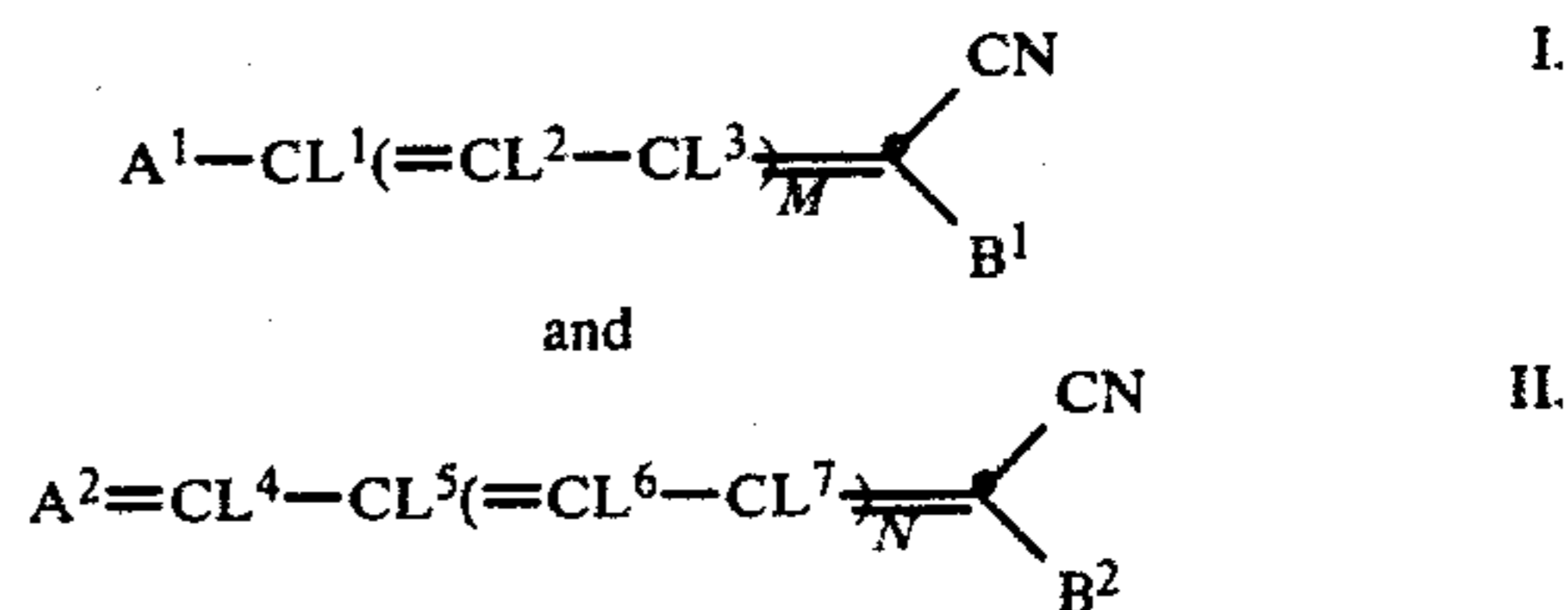

wherein:

M and N may be zero, one or two;

L¹, L², L³, L⁴, L⁵, L⁶, and L⁷ may be cyano hydrogen, substituted or unsubstituted alkyl, alkoxy, aralkyl, aryl or heterocycyl and in addition any two of L¹, L² and L³ and any two of L⁴, L⁵, L⁶ and L⁷ may together represent the elements needed to complete a carbocyclic or heterocyclic ring having from 5-12 carbon atoms;

A¹ may be the same as A² defined below and in addition may represent an aryl or diarylamino substituted, or unsubstituted aryl, (e.g., phenyl, naphthyl, anthryl)

or a substituted or unsubstituted heterocyclic nucleus such as thiophene, benzo[b]thiophene, naphtho[2,3-b]thiophene, furan, isobenzofuran, chromene, pyran, xanthene, pyrrole, 2H-pyrrole, pyrazole, indolizine, indoline, indole, indazole, carbazole, pyrimidine, isothiazole, isoxazole, furazan, chroman, isochroman, 1,2,3,4-tetrahydroquinoline; 4H-pyrrolo[3,2,1-ij]quinoline; 1,2-dihydro-4H-pyrrolo[3,2,1-ij]quinoline; 1,2,5,6-tetrahydro-4H-pyrrolo[3,2,1-ij]quinoline; 1H,5H-benzo[ij]quinolizine; 2,3-dihydro-1H,5H-benzo[ij]quinolizine; 2,3-dihydro-1H,5H-benzo[ij]quinolizine and 2,3,6,7-tetrahydro-1H,5H-benzo[ij]quinolizine, 10,11-dihydro-9H-benzo[a]xanthen-8-yl; 6,7-dihydro-5H-benzo[b]pyran-7-yl and pyrrolo[2,1-b]benzothiazole;

A² represents a basic substituted or unsubstituted heterocyclic nucleus. Representative such nuclei include:

- (a) an imidazole nucleus, such as imidazole and 4-phenylimidazole;
- (b) a 3H-indole nucleus such as 3H-indole, 3,3-dimethyl-3H-indole, 3,3,5-trimethyl-3H-indole;
- (c) a thiazole nucleus such as thiazole, 4-methylthiazole, 4-phenylthiazole, 5-methylthiazole, 5-phenylthiazole, 4,5-dimethylthiazole, 4,5-diphenylthiazole, 4-(2-thienyl)thiazole;
- (d) a benzothiazole nucleus such as benzothiazole, 4-chlorobenzothiazole, 5-chlorobenzothiazole, 6-chlorobenzothiazole, 7-chlorobenzothiazole, 4-methylbenzothiazole, 5-methylbenzothiazole, 6-methylbenzothiazole, 5-bromobenzothiazole, 6-bromobenzothiazole, 4-phenylbenzothiazole, 5-phenylbenzothiazole, 4-methoxybenzothiazole, 5-methoxybenzothiazole, 6-methoxybenzothiazole, 5-iodobenzothiazole, 6-iodobenzothiazole, 4-ethoxybenzothiazole, 5-ethoxybenzothiazole, tetrahydrobenzothiazole, 5,6-dimethoxybenzothiazole, 5,6-dioxymethylenebenzothiazole, 5-hydroxybenzothiazole and 6-hydroxybenzothiazole;
- (e) a naphthothiazole nucleus such as naphtho[1,2-d]thiazole, naphtho[2,1-d]thiazole, naphtho[2,3-d]thiazole, 5-methoxynaphtho[2,1-d]thiazole, 5-ethoxynaphtho[2,1-d]thiazole, 8-methoxynaphtho[1,2-d]thiazole and 7-methoxynaphtho[1,2-d]thiazole;
- (f) a thianaphtheno-7',6',4,5-thiazole nucleus such as 4'-methoxythianaphtheno-7',6',4,5-thiazole;
- (g) an oxazole nucleus such as 4-methyloxazole, 5-methyloxazole, 4-phenyloxazole, 4,5-diphenyloxazole, 4-ethyloxazole, 4,5-dimethyloxazole and 5-phenyloxazole;
- (h) a benzoxazole nucleus such as benzoxazole, 5-chlorobenzoxazole, 5-methylbenzoxazole, 5-phenylbenzoxazole, 6-methylbenzoxazole, 5,6-dimethylbenzoxazole, 4,6-dimethylbenzoxazole, 5-methoxybenzoxazole, 5-ethoxybenzoxazole, 5-chlorobenzoxazole, 6-methoxybenzoxazole, 5-hydroxybenzoxazole and 6-hydroxybenzoxazole;
- (i) a naphthoxazole nucleus such as naphtho[1,2-d]oxazole and naphtho[2,1-d]oxazole;
- (j) a selenazole nucleus such as 4-methylselenazole and 4-phenylselenazole;
- (k) a benzoselenazole nucleus such as benzoselenazole, 5-chlorobenzoselenazole, 5-methoxybenzoselenazole, 5-hydroxybenzoselenazole and tetrahydrobenzoselenazole;
- (l) a naphthoselenazole nucleus such as naphtho[1,2-d]selenazole, naphtho[2,1-d]selenazole;

- (m) a thiazoline nucleus such as thiazoline and 4-methylthiazoline;
- (n) a quinoline nucleus such as quinoline, 3-methylquinoline, 5-methylquinoline, 7-methylquinoline, 8-methylquinoline, 6-chloroquinoline, 8-chloroquinoline, 6-methoxyquinoline, 6-ethoxyquinoline, 6-hydroxyquinoline and 8-hydroxyquinoline;
- (o) an isoquinoline nucleus such as isoquinoline and 3,4-dihydroisoquinoline;
- (p) a benzimidazole nucleus such as 1-ethylbenzimidazole and 1-phenylbenzimidazole;
- (q) a pyridine nucleus such as pyridine and 5-methylpyridine;
- (r) a pyrrolo[1,2-a]pyridine nucleus;
- (s) an acenaphthothiazole nucleus; and
- (t) tetrazole nucleus such as 1H-tetrazole.

B¹ and B² represent any of a wide variety of electro-negative groups such as cyano, cyanophenyl, carboxy, alkoxy-carbonyl, aryloxy-carbonyl, alkylsulfonyl, acyl, arylcarbonyl, heteroyl groups such as benzoyl, benzofuroyl, nitro, nitro substituted aryl, sulfonyl, fluorosulfonyl, trifluoromethylsulfonyl, carbamoyl, arylcarbamoyl, alkylcarbamoyl, etc., or

- 25 B² may be combined with $\{CL^6-CL^7\}$ or $\{CL^4-CL^5\}$ to provide sufficient atoms to form a substituted pyridine nucleus such as 2-amino-3,7-dicyano-4,6-dimethyl-1,5-pyridine.

Unless stated otherwise, alkyl refers to aliphatic hydrocarbon groups of generally 1-20 carbon atoms such as methyl, ethyl, propyl, isopropyl, butyl, heptyl, dodecyl, octadecyl, etc.; aryl refers to aromatic ring groups of generally 6-20 carbons such as phenyl, naphthyl, anthryl or to alkyl or aryl substituted aryl groups such as tolyl, ethylphenyl, biphenyl, etc.; aralkyl refers to aryl substituted alkyl groups such as benzyl, phenethyl, etc.; carbocyclic ring refers to saturated cycloalkyl groups which may have alkyl, aryl or aralkyl substituents such as cyclopropyl, cyclopentyl, cyclohexyl, 5,5-dimethylcyclohexyl, etc.

When used in an electrophoretic migration imaging process, charge-bearing, electrically photosensitive particles formulated from the materials of the present invention are positioned between two spaced electrodes; preferably these particles are contained in an electrically insulating carrier such as an electrically insulating liquid or an electrically insulating, liquefiable matrix material, e.g., a thixotropic or a heat- and/or solvent-softenable material, which is positioned between the spaced electrodes. While so positioned between the spaced electrodes, the photosensitive particles are subjected to an electric field and exposed to a pattern of activating radiation. As a consequence, the charge-bearing, electrically photosensitive particles undergo a radiation-induced variation in their charge polarity and migrate to one or the other of the electrode surfaces to form on at least one of these electrodes an image pattern representing a positive-sense or negative-sense image of the original radiation exposure pattern.

BRIEF DESCRIPTION OF THE DRAWINGS

FIG. 1 represents diagrammatically a typical imaging apparatus for carrying out the electrophoretic migration imaging process of the invention.

DESCRIPTION OF THE PREFERRED EMBODIMENTS

In accordance with the preferred embodiment of the present invention there is provided a group of materials

which are useful in electrophoretic migration imaging dispersions, images and processes. Said materials have a structure according to general Formula I or II wherein:

$L^1, L^2, L^3, L^4, L^5, L^6,$ and L^7 which may be the same or different represent hydrogen, cyano, methyl, methoxy, ethyl, ethoxy, phenyl, benzoyl, 2-thienyl, benzofuryl, 3-dicyanomethylenebutyl, 2-oxo-2H-benzo[b]pyran-3-yl, and 2-hydroxyphenyl-1-carboxyethenyl or any two of $L^1, L^2,$ and L^3 or $L^4, L^5, L^6,$ and L^7 may represent the atoms needed to complete a nucleus selected from the group consisting of dihydronaphthalene, 1H-indene, acenaphthalene, pyrimidinedione and cyclohexene;

A^1 represents an alkyl or aryl group or a nucleus selected from the group consisting of indole; 1,2,5,6-tetrahydro-4H-pyrrolo-[c,2,1-ij]quinoline; 2,3,6,7-tetrahydro-1H,5H-benzo[ij]quinolizine and pyrrolo [2,1-b]benzothiazole; ditolyaminophenyl; and

A^2 represents a substituted and unsubstituted nucleus selected from the group consisting of 3H-indole, benzothiazole, naphthothiazole, benzimidazole, 2-pyridine,

pyrrolo[1,2-a]pyridine and benzoxazole, benzoselenazole and acenaphthothiazole;

B^1 and B^2 represent cyano, cyanophenyl, ethoxycarbonyl, naphthoyl, benzoyl, furoyl, and dihydroxybenzoyl; or

B^2 be combined with $=CL^6-CL^7=$ or $=CL^4-CL^5=$ to provide sufficient atoms to form a substituted pyridine nucleus.

In general the materials of Formulas I and II which have been found to be electrophotosensitive tend to exhibit a maximum absorption wavelength, λ_{max} , within the range of from about 420 to about 750 nm. A variety of different materials within the class defined by Formulas I and II have been tested and found to exhibit useful levels of electrical photosensitivity in electrophoretic migration imaging processes.

A partial listing of representative such materials are disclosed in Table I. In Table I Et represents $-C_2H_5$ and O represents phenyl. Materials of the type disclosed and claimed herein are also disclosed in, among others, U.S. Pat. No. 2,538,009; No. 2,721,799; No. 2,860,891; No. 2,860,981 and No. 2,860,982.

TABLE I

Number	Material	Color
1		Orange
2		Orange
3		Purple
4		Brown
5		Purple

TABLE I-continued

Number	Material	Color
6		Purple
7		Red
8		Magenta
9		Orange
10		Orange
11		Red
12		Orange
13		Purple
14		Purple

TABLE I-continued

Number	Material	Color
15		Blue
16		Purple
17		Purple
18		Purple
19		Pink
20		Blue
21		Green
22		Blue

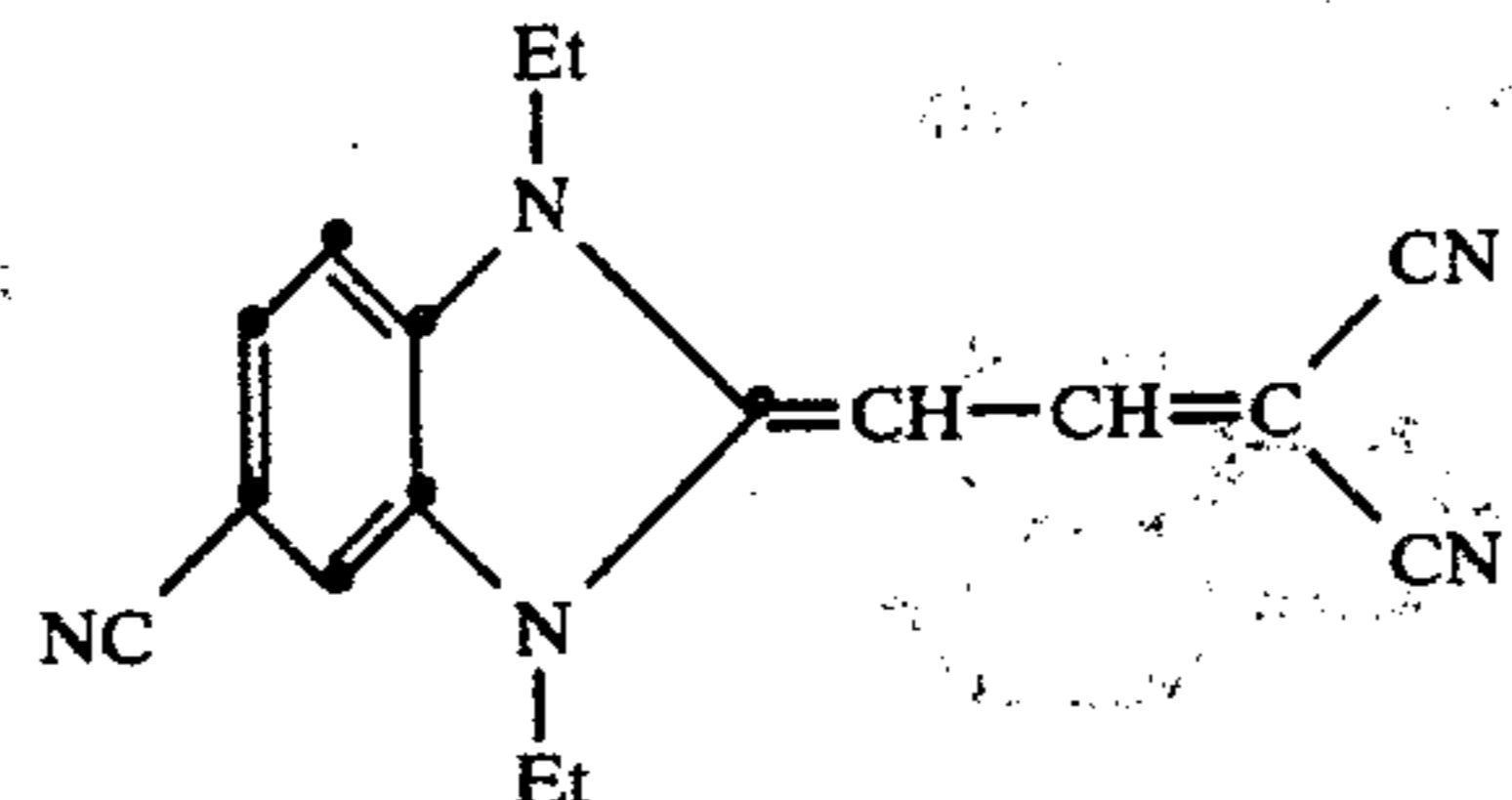
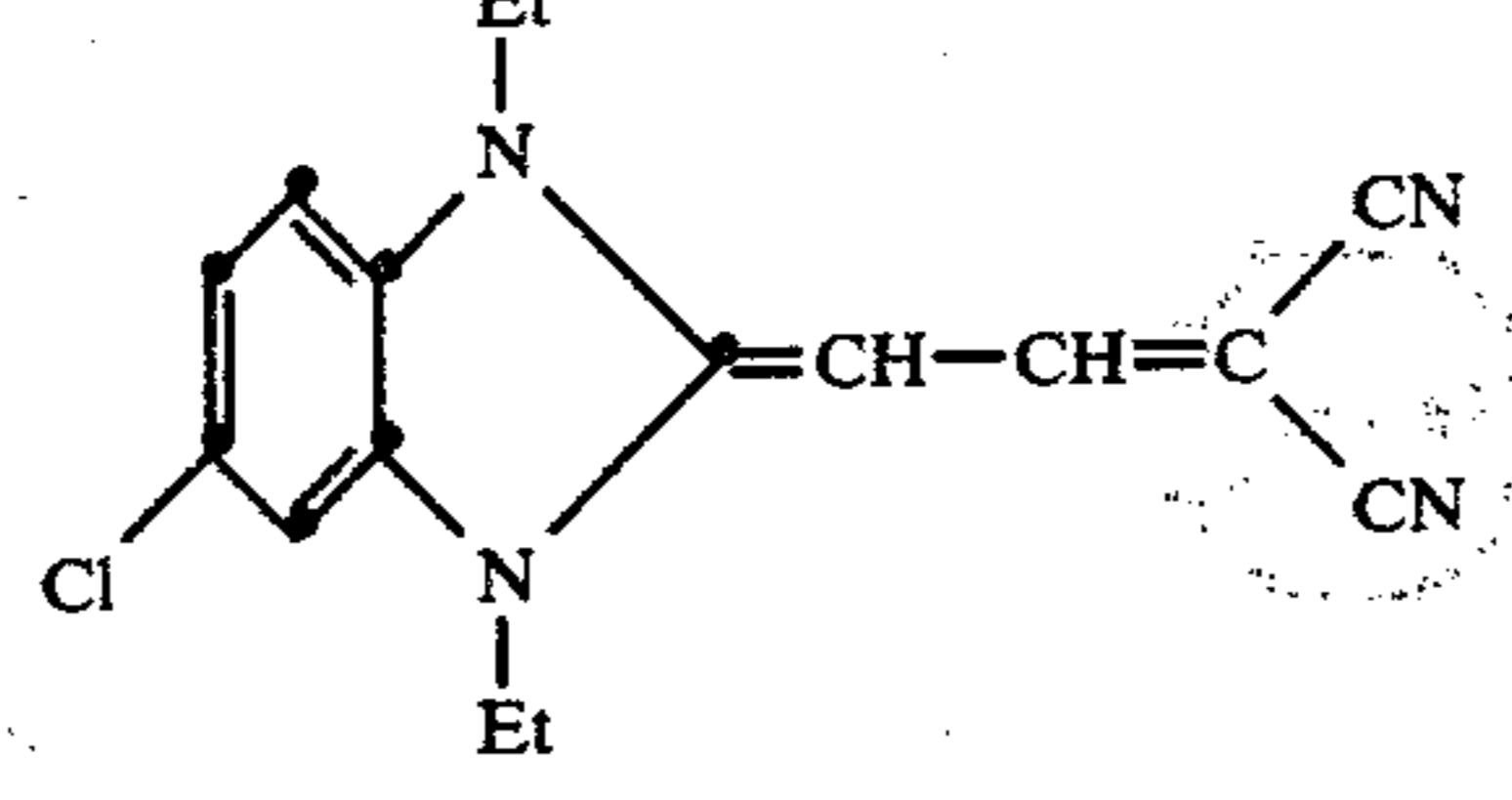
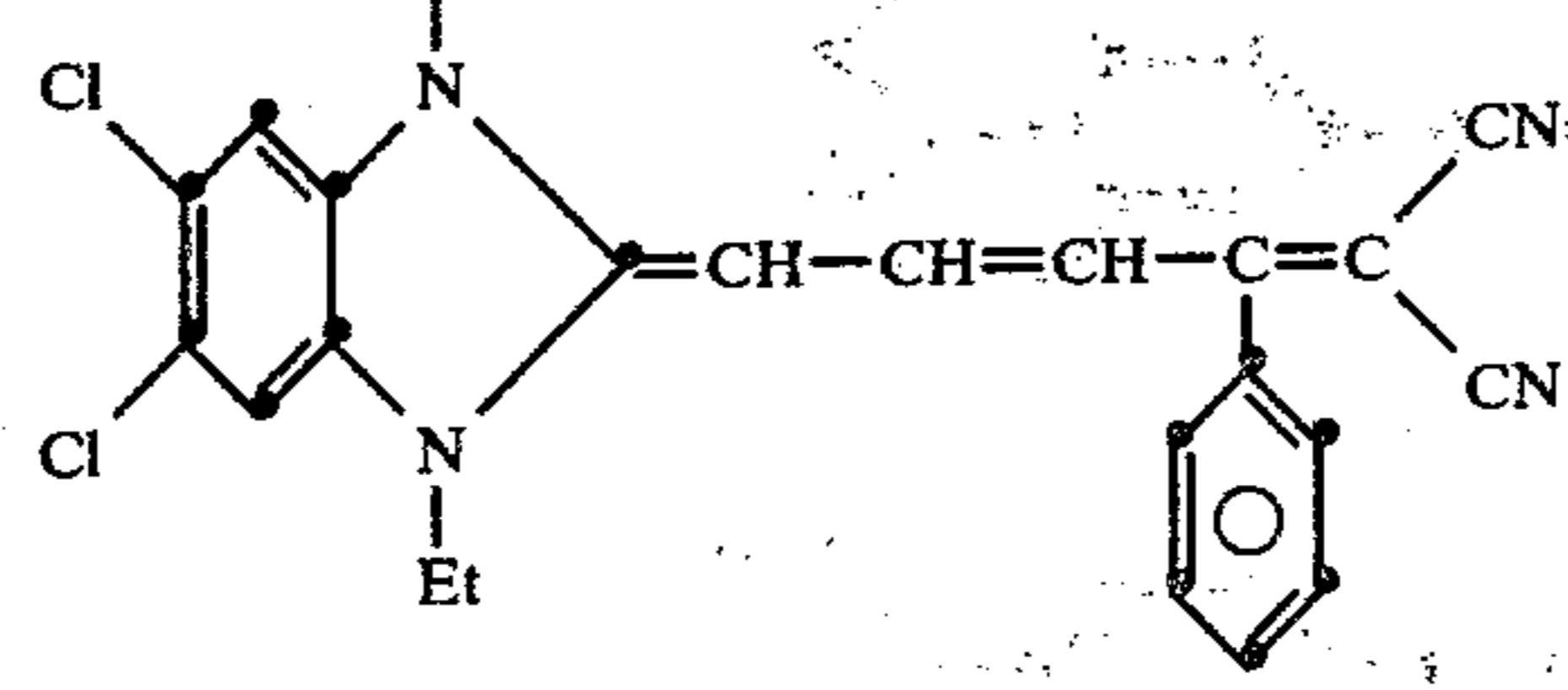
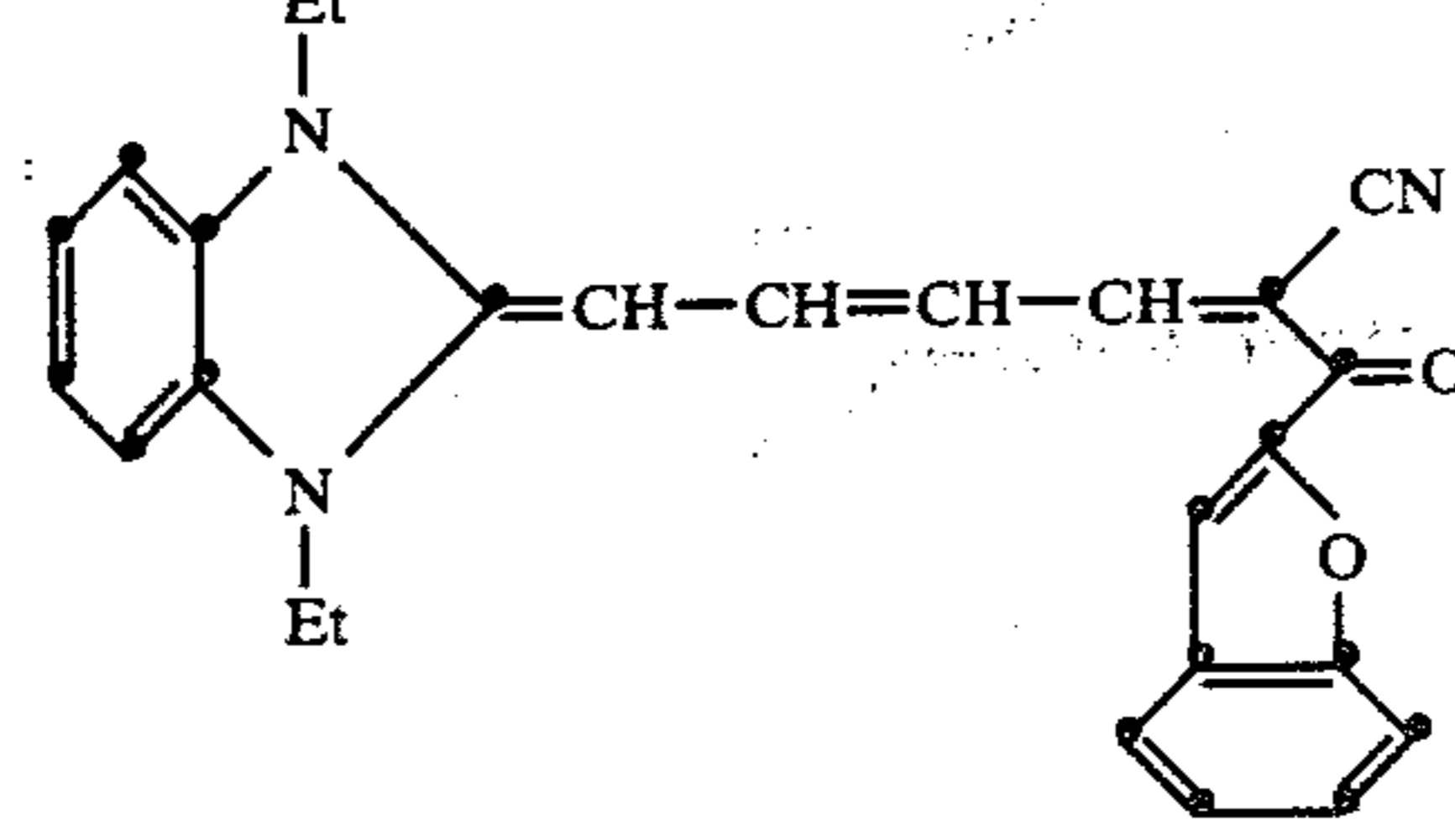
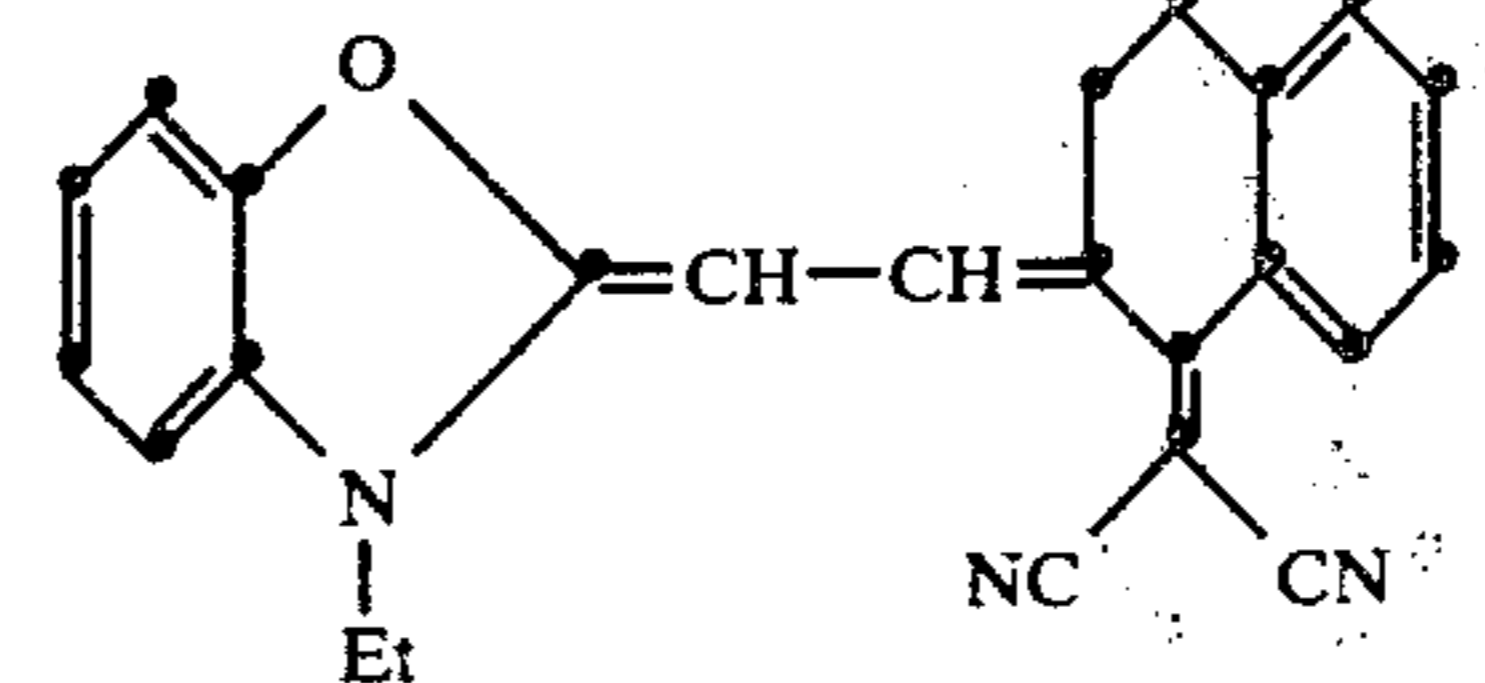
TABLE I-continued

Number	Material	Color
23		Blue
24		Purple
25		Brown
26		Purple
27		Purple
28		Blue
29		Blue
30		Blue

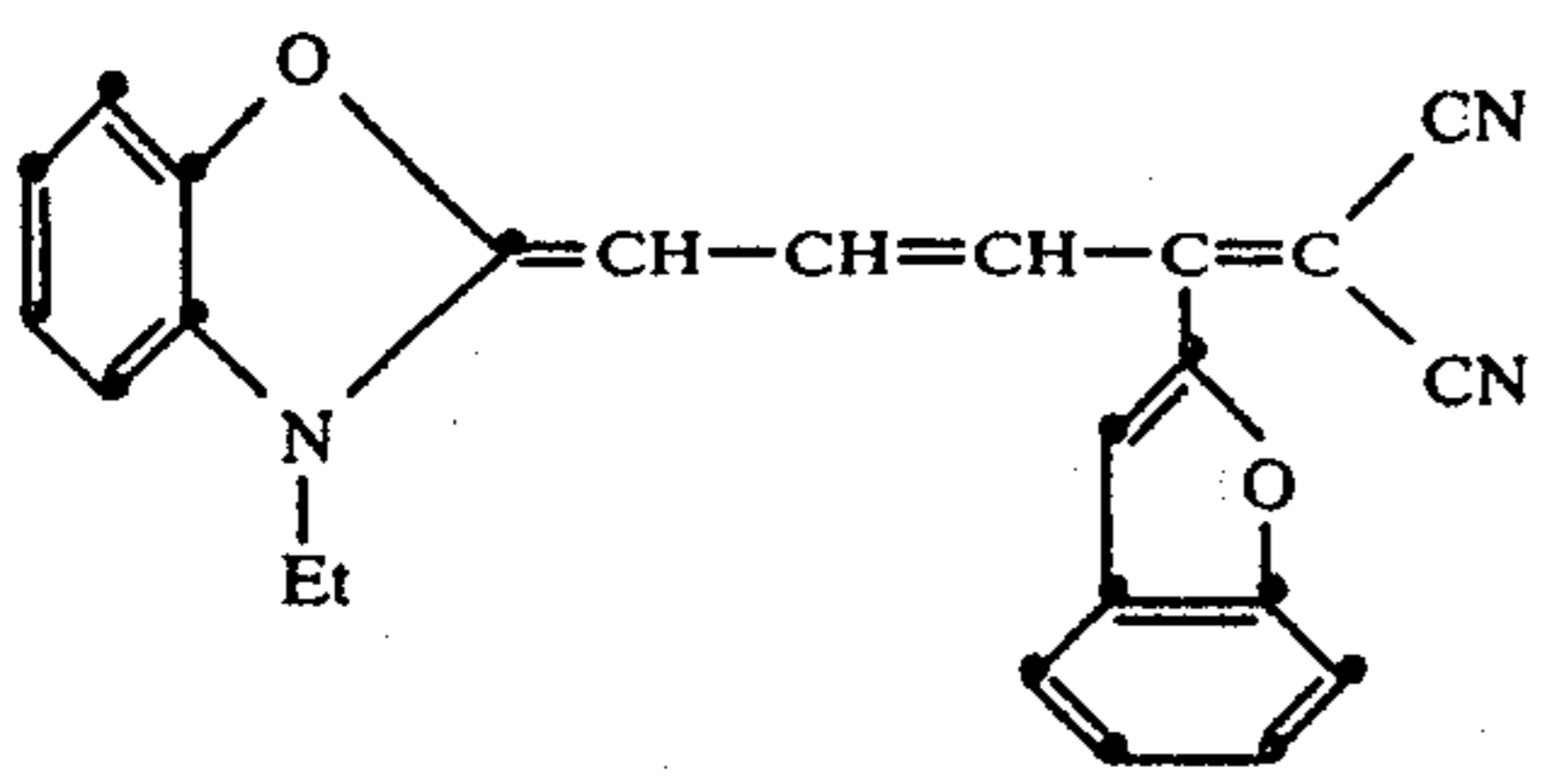
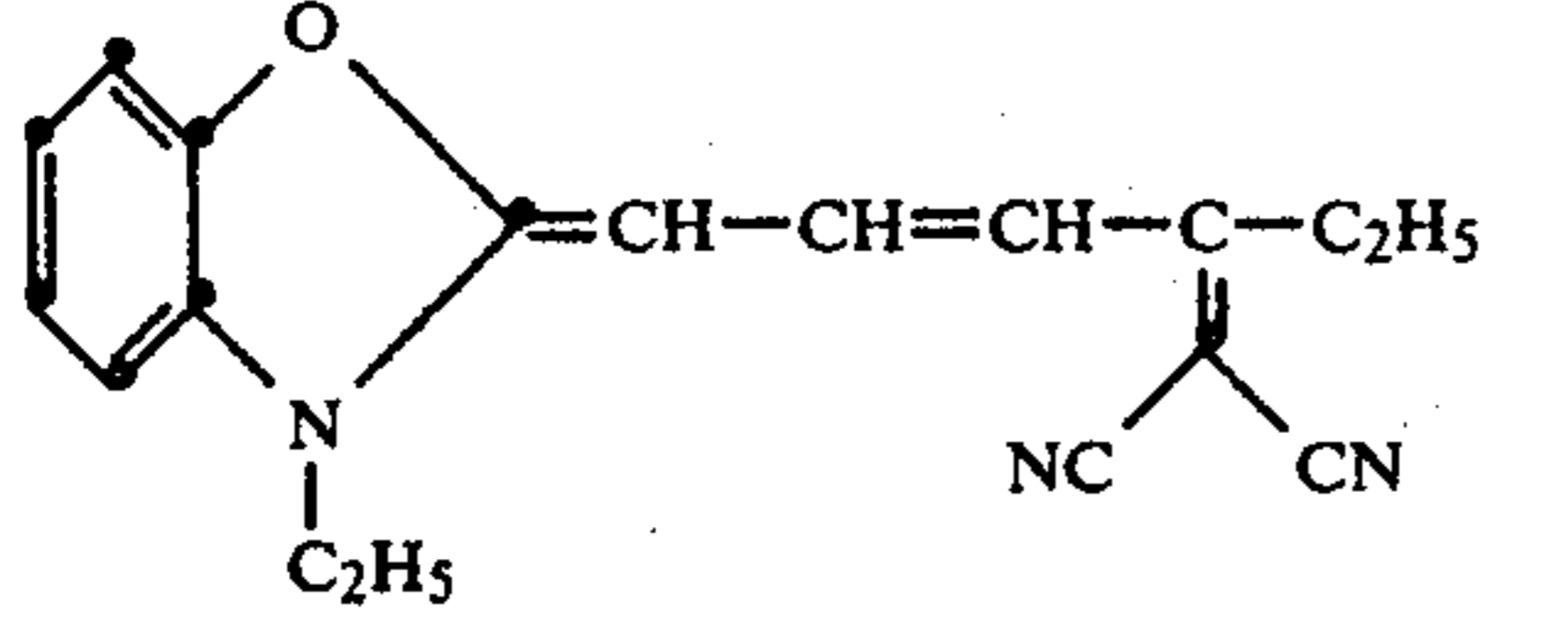
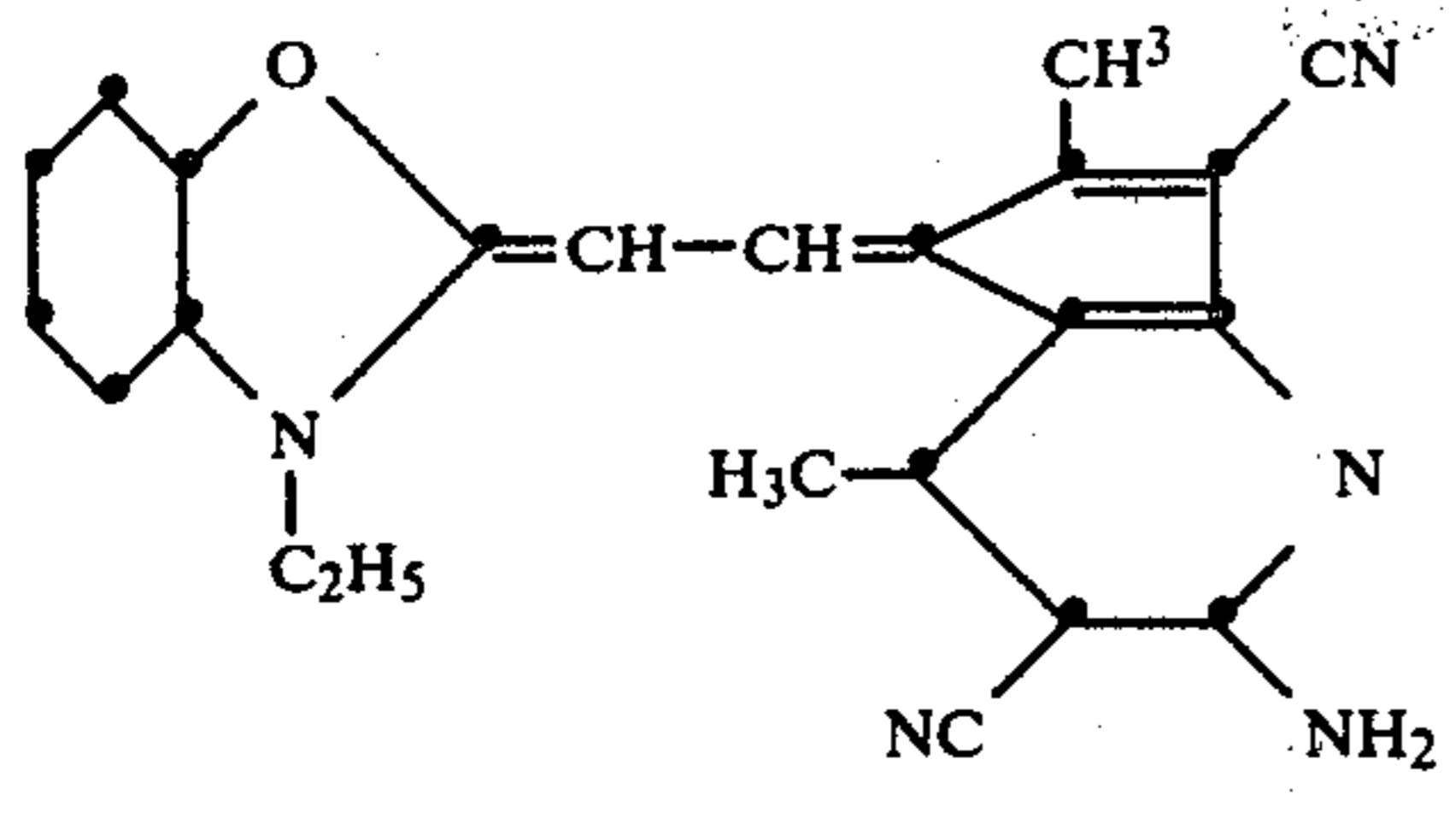
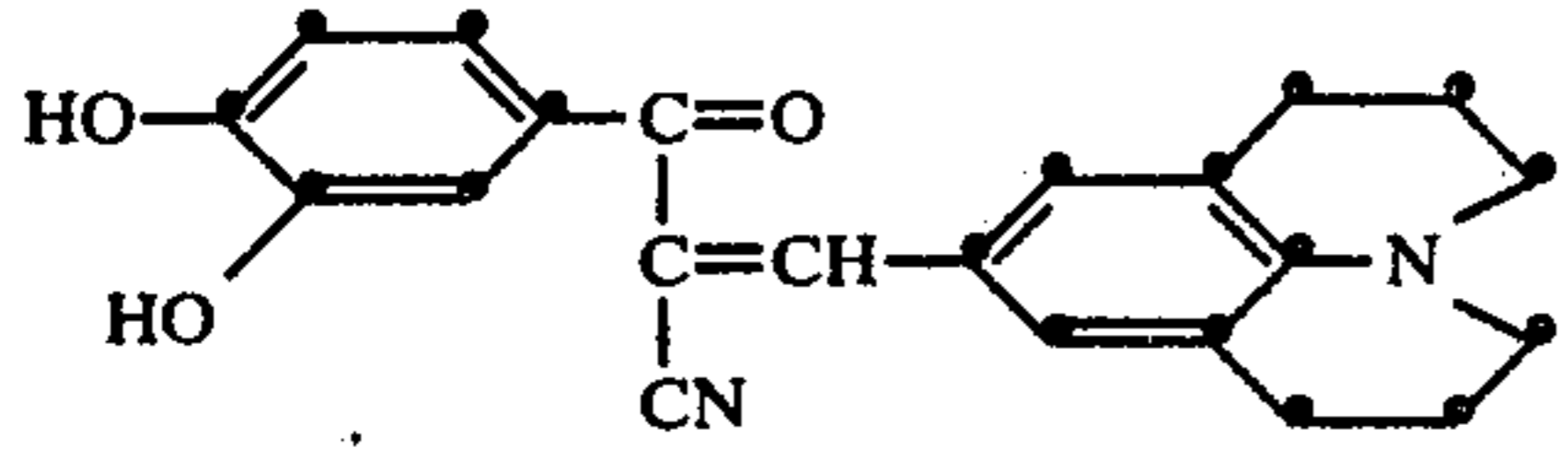
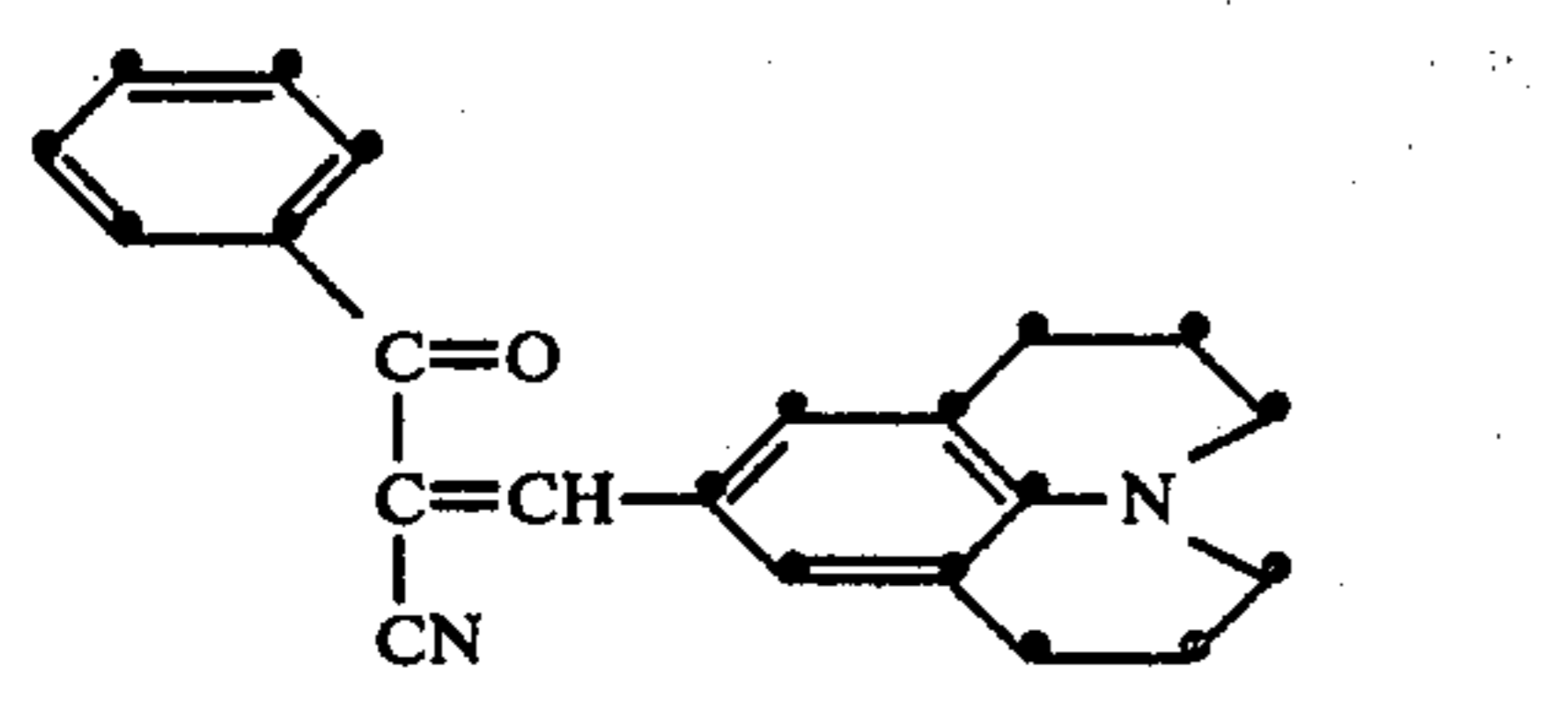
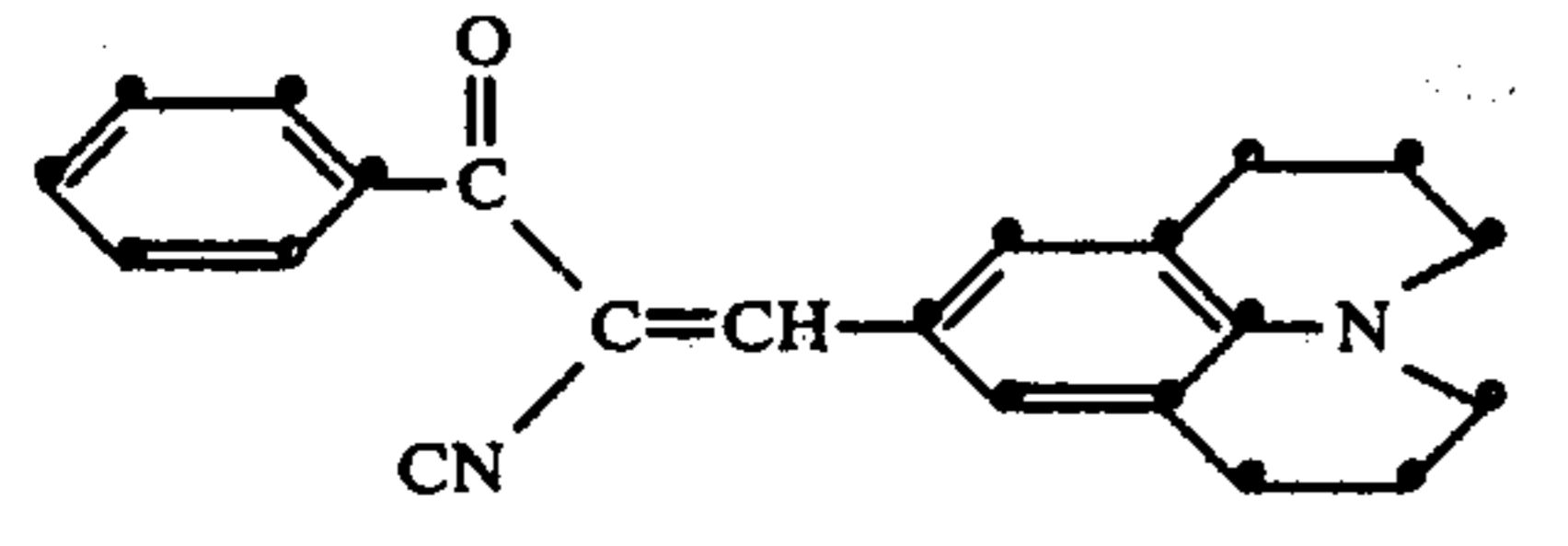
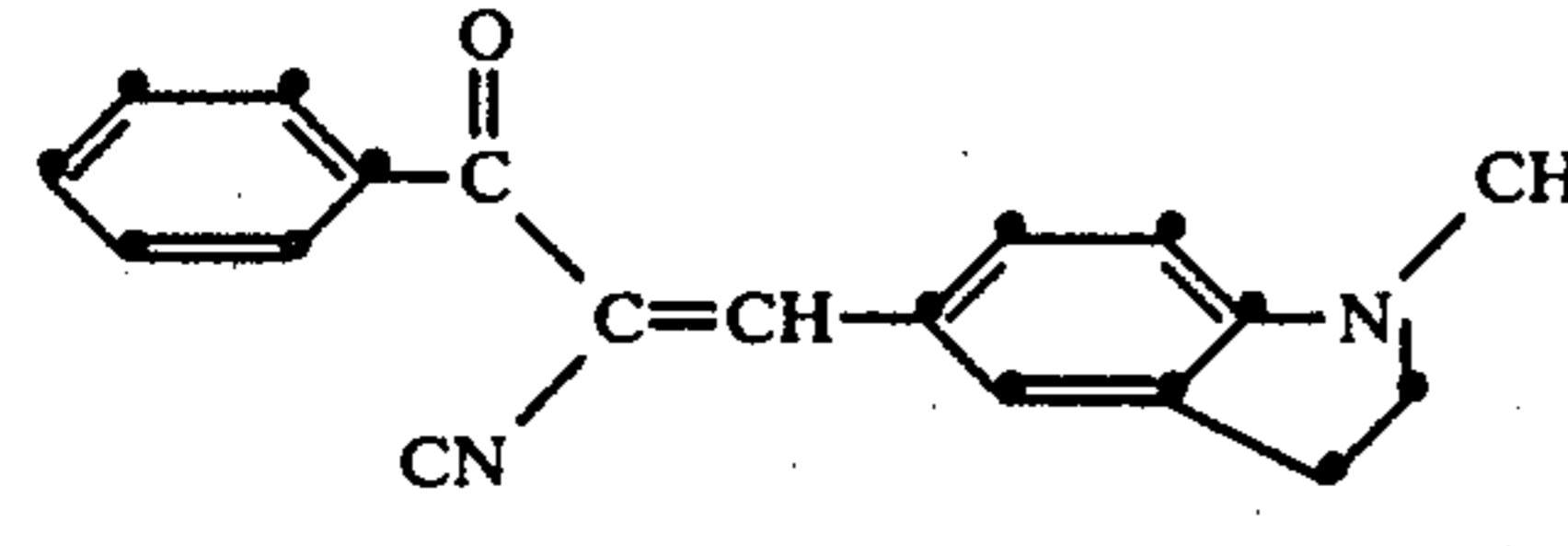
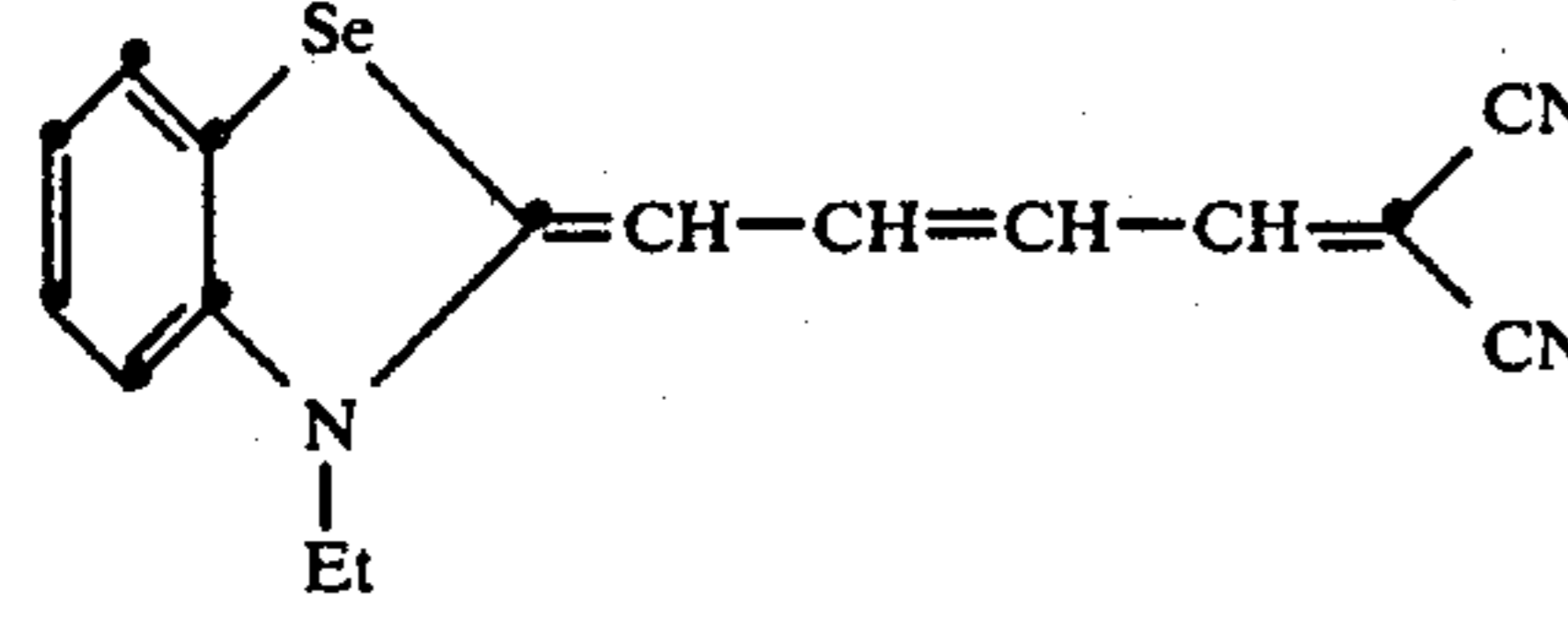
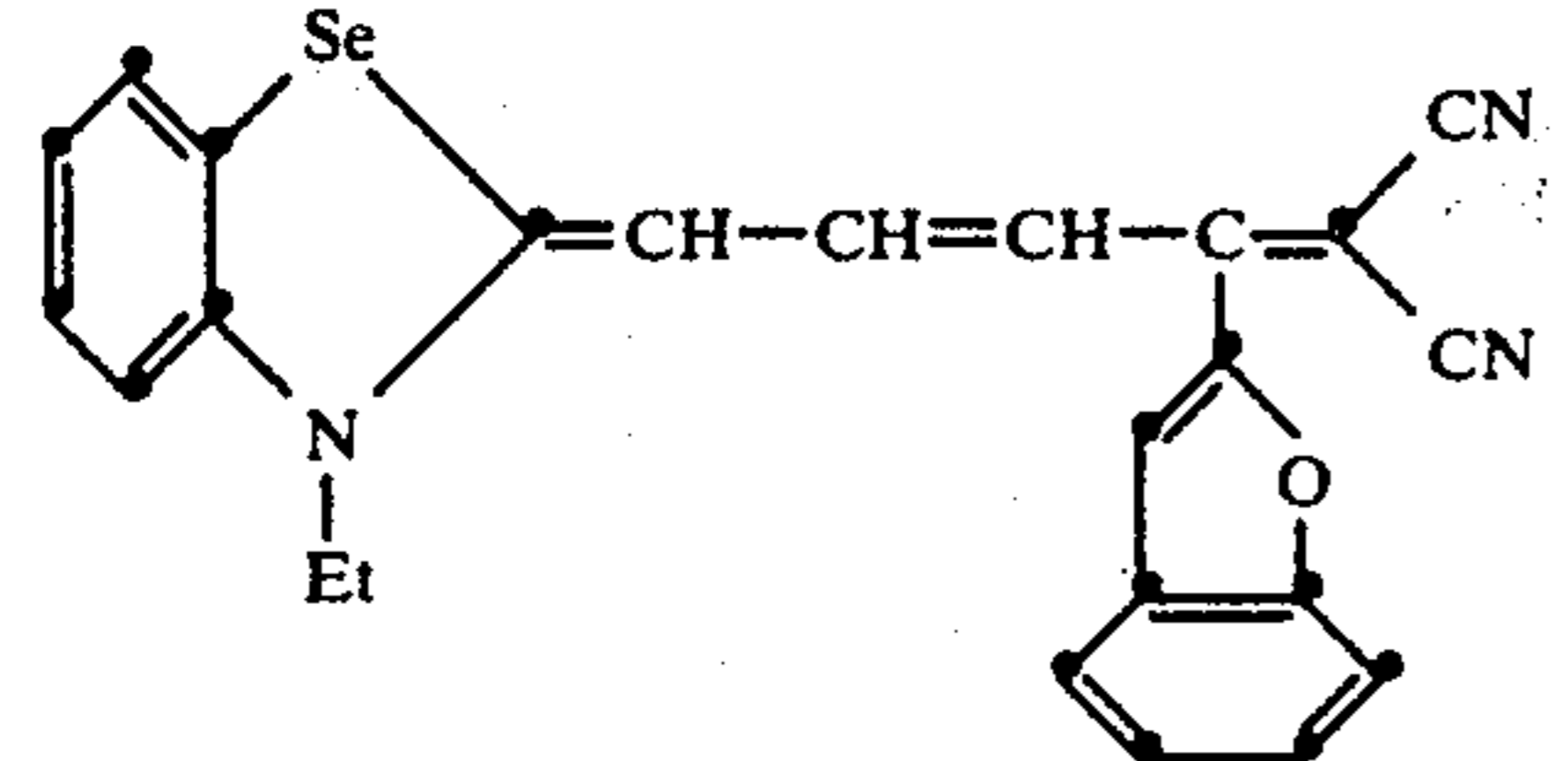
TABLE I-continued

Number	Material	Color
31		Pink
32		Orange
33		Yellow
34		Yellow
35		Orange
36		Orange
37		Orange
38		Purple

TABLE I-continued

Number	Material	Color
39		Purple
40		Purple
41		Purple
42		Orange
43		Purple
44		Purple
45		Yellow
46		Orange

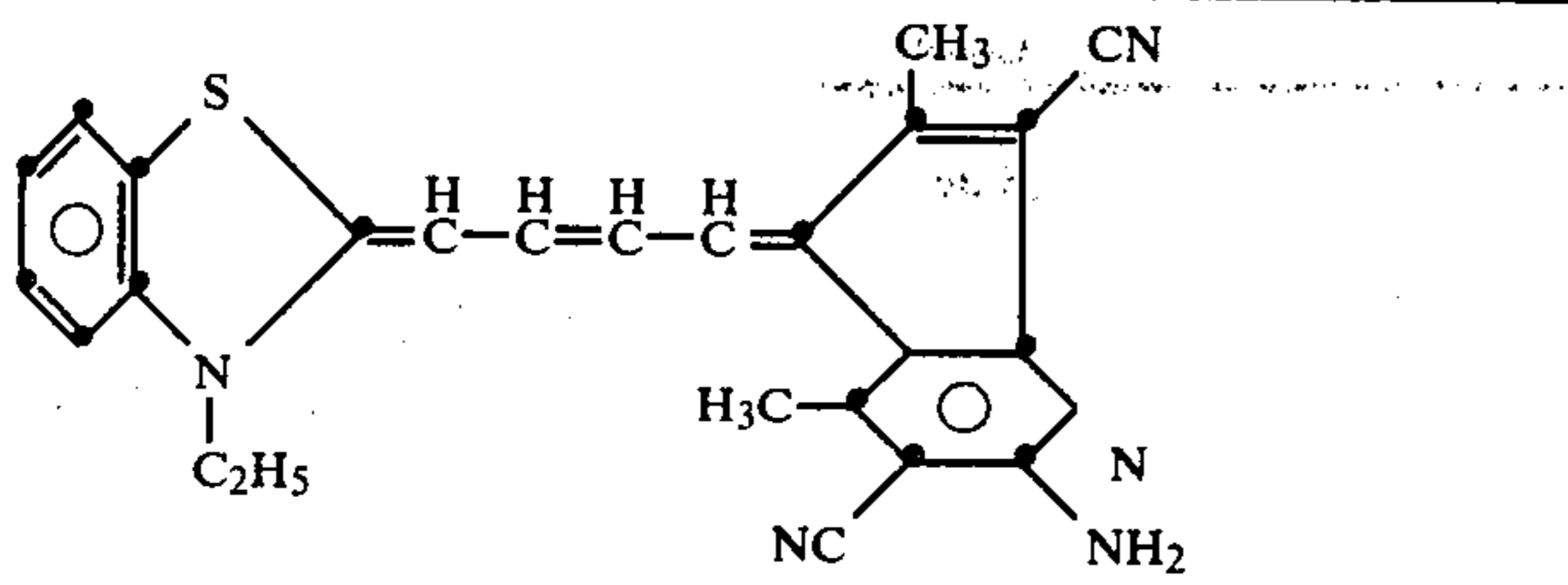
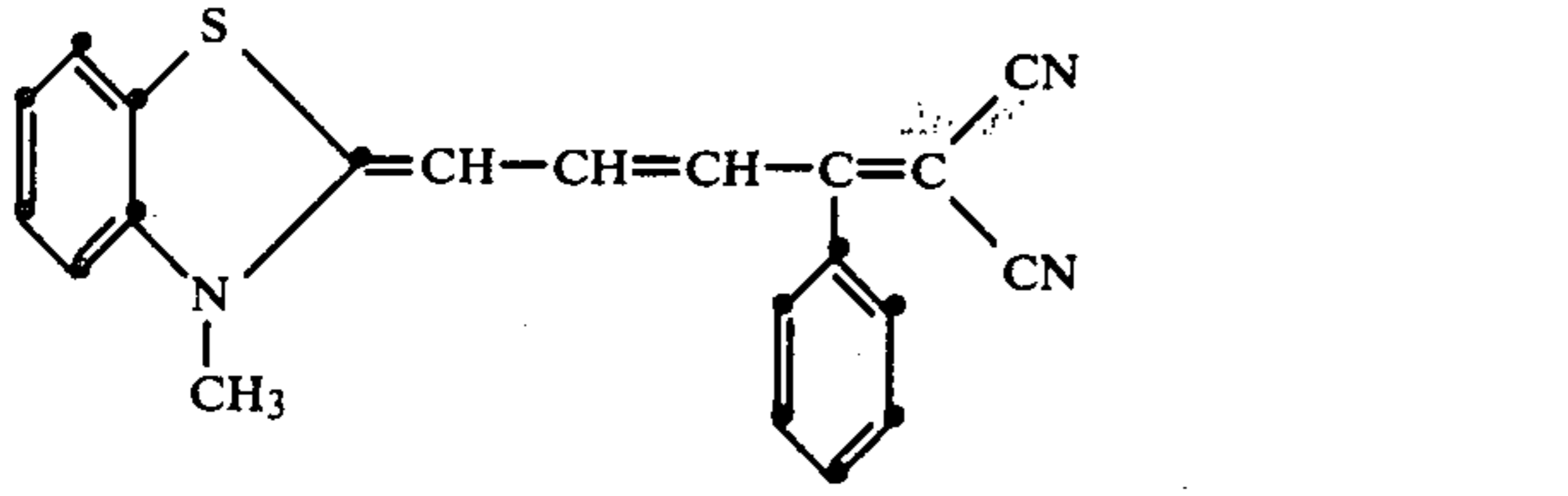
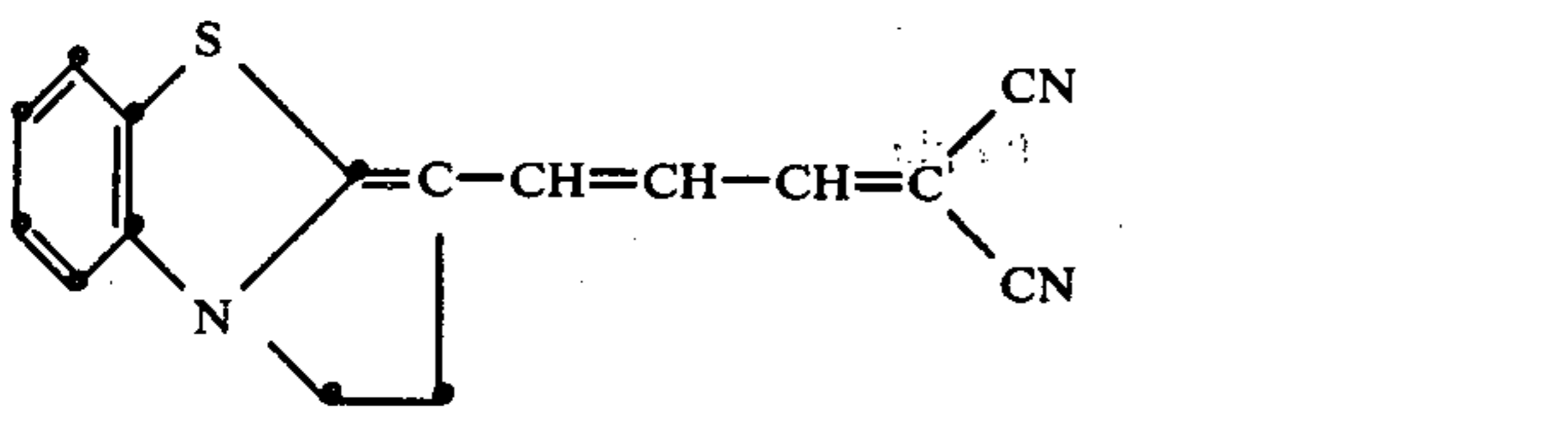
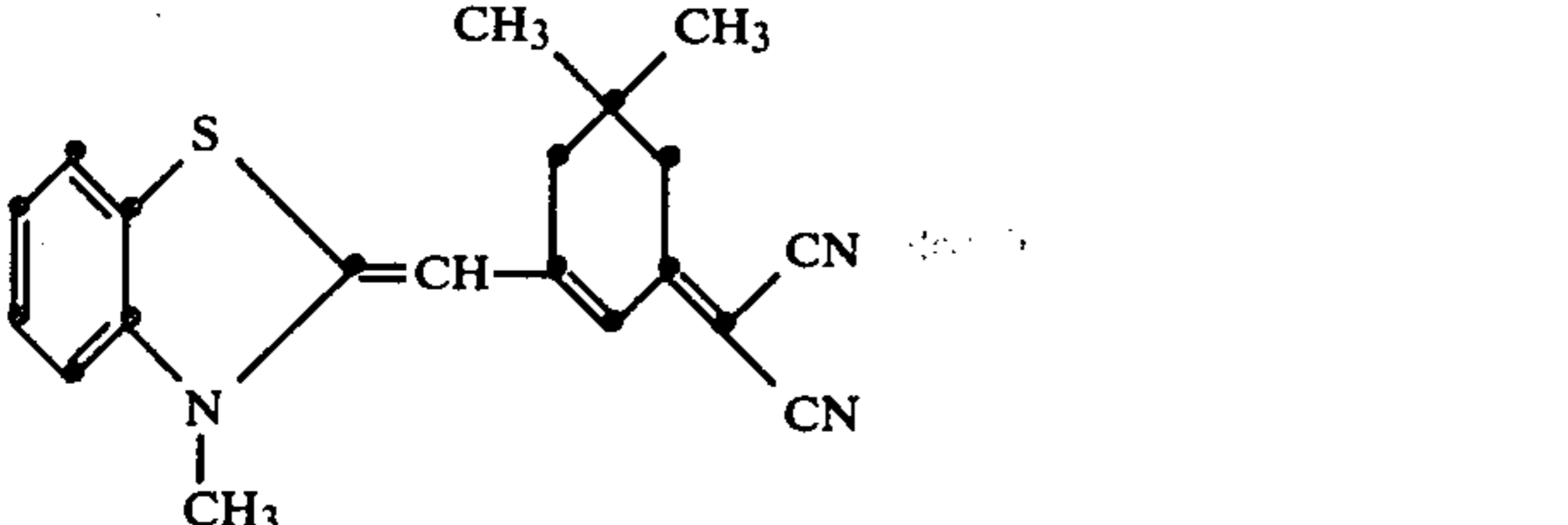
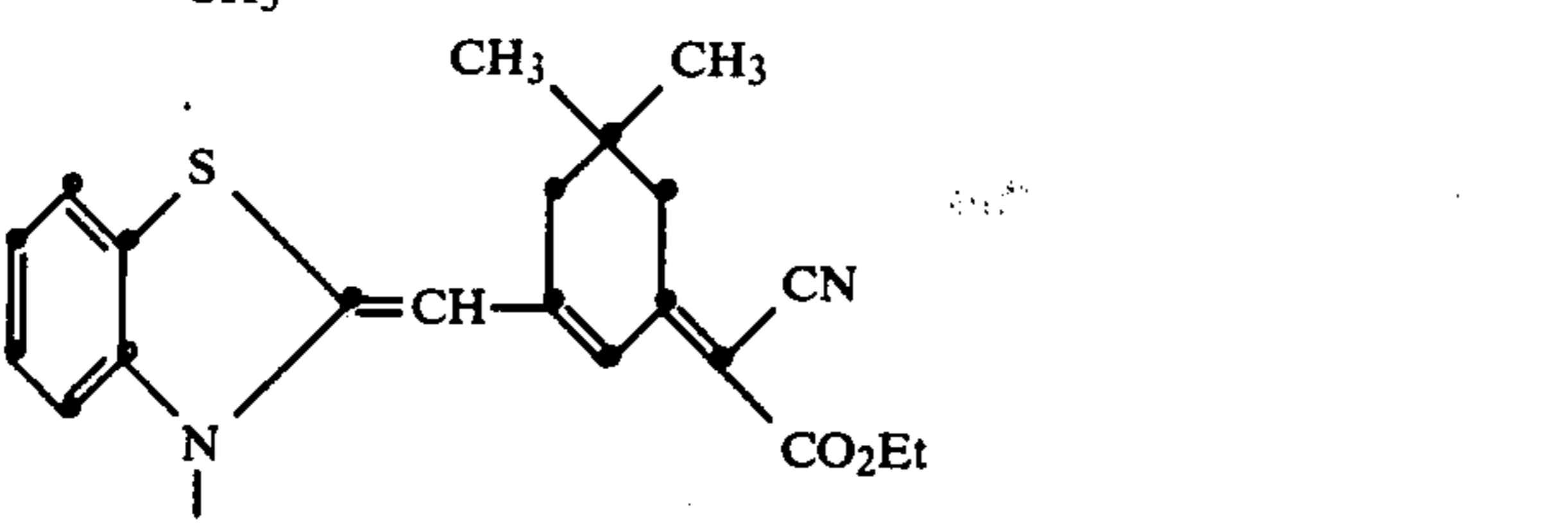
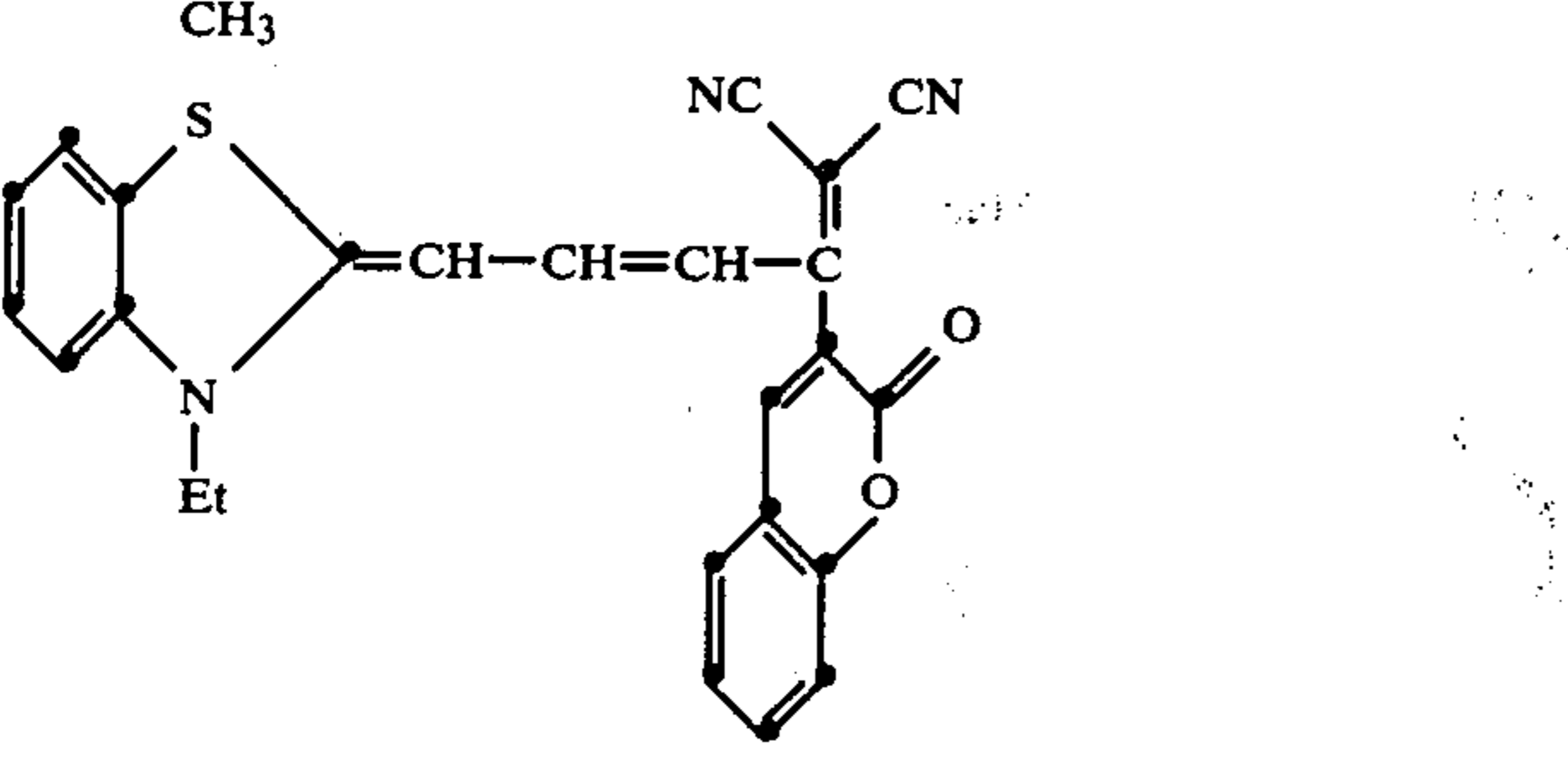
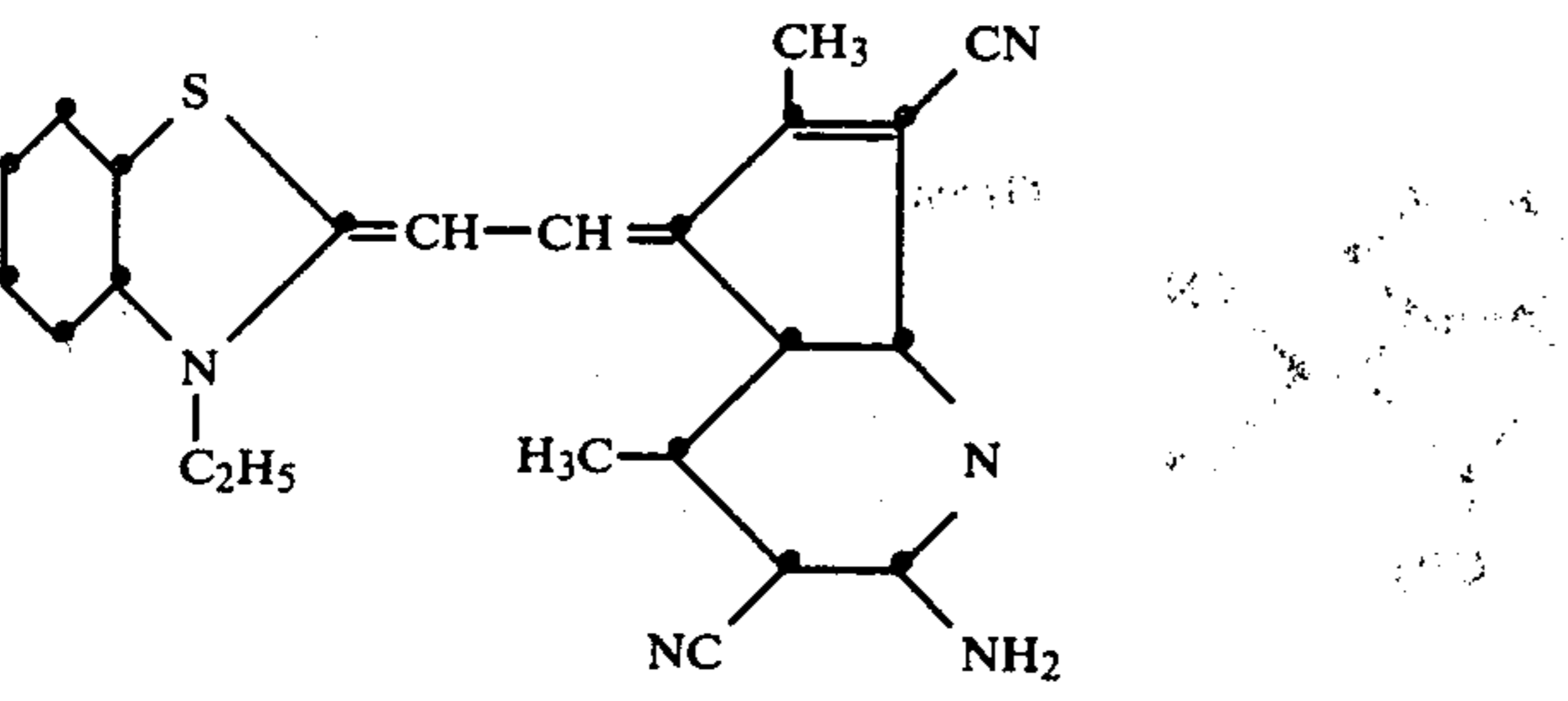
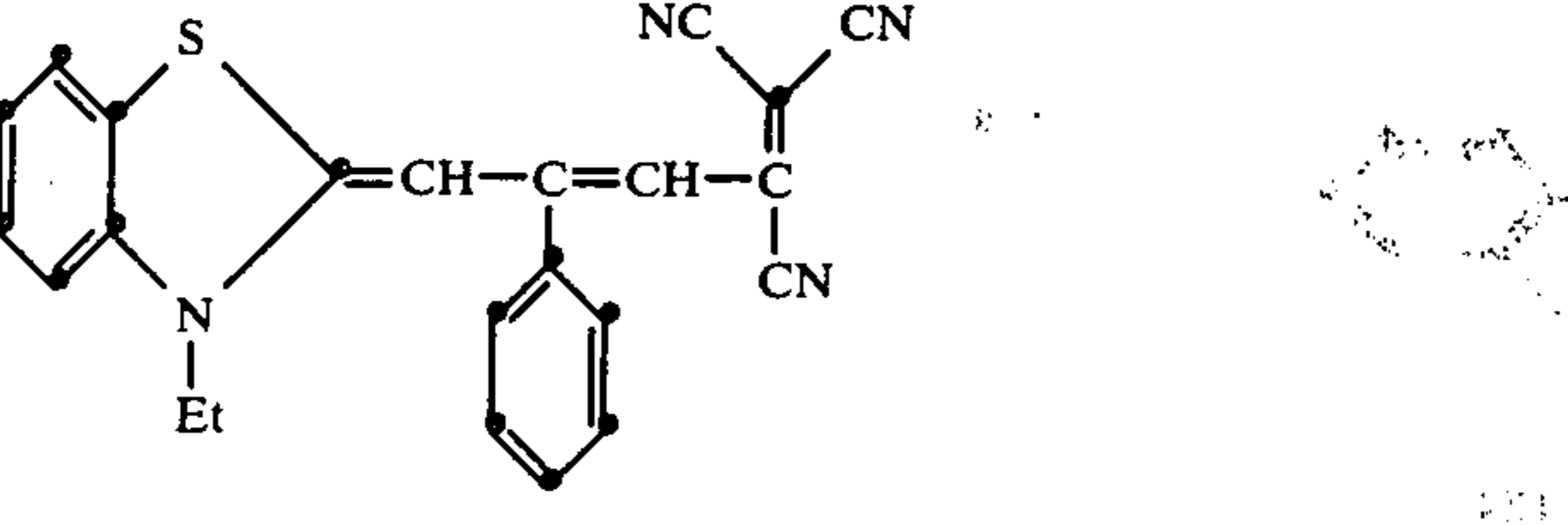
TABLE I-continued

Number	Material	Color
47		Red
48		Magenta
49		Gray
50		Pink
51		Orange
52		Red
53		Red
54		Gray
55		Orange
56		Pink

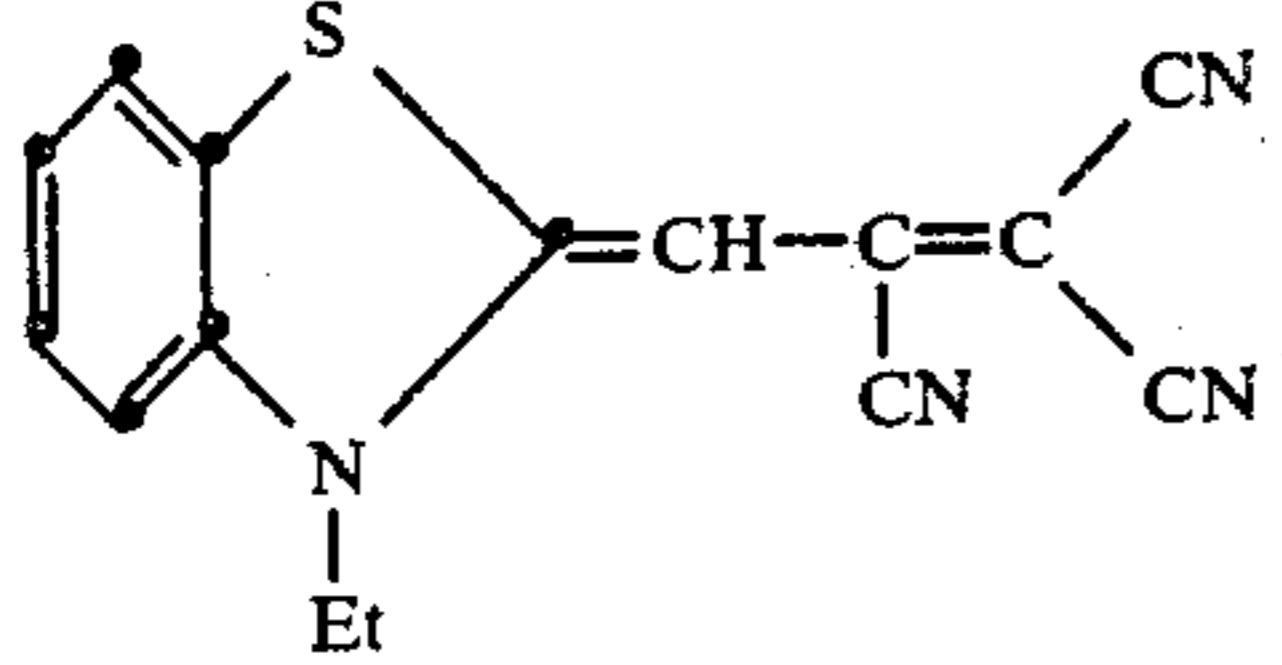
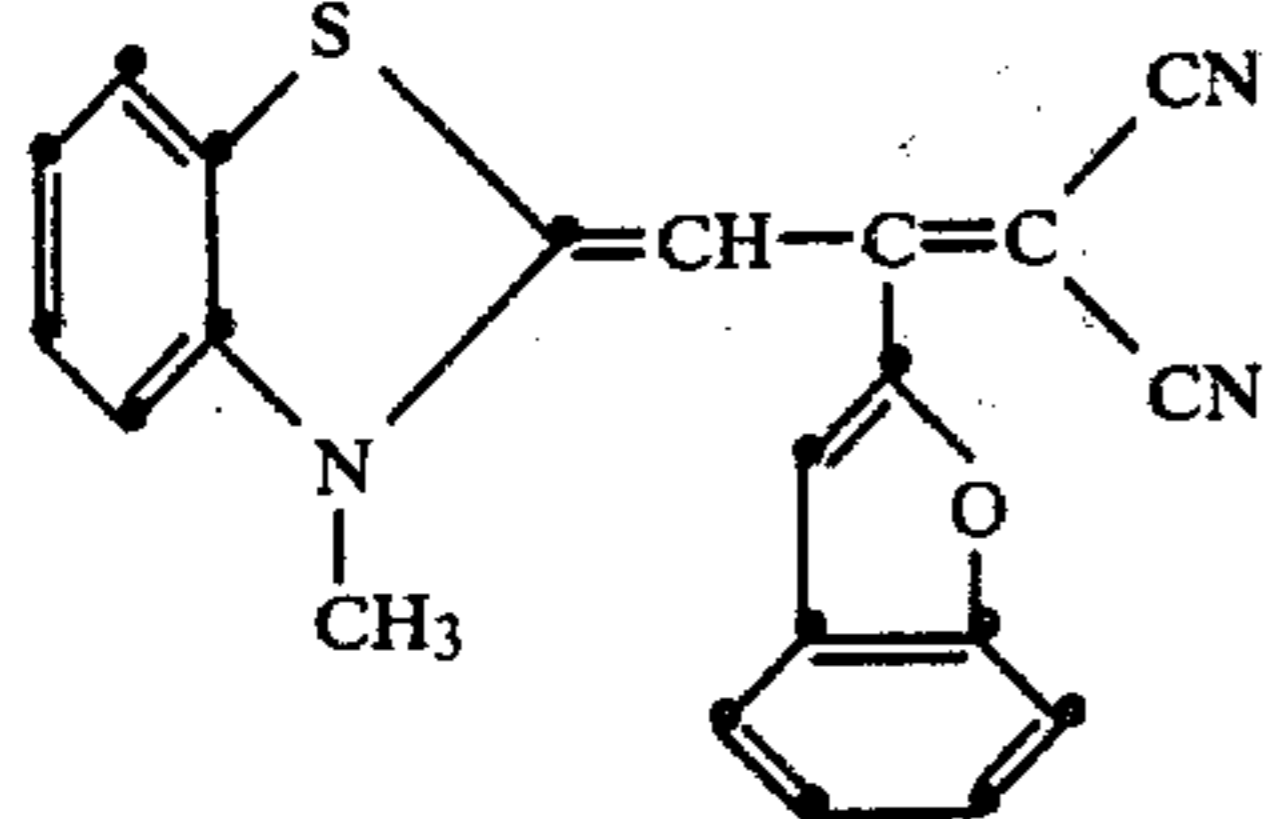
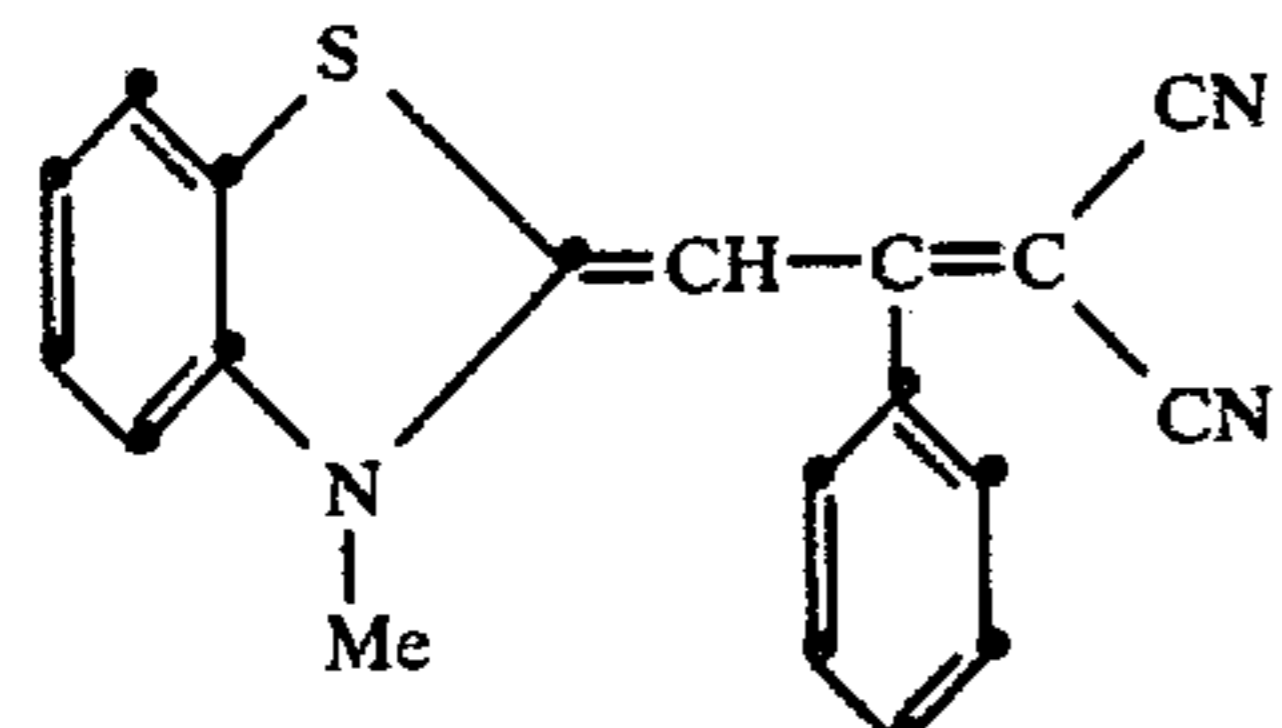
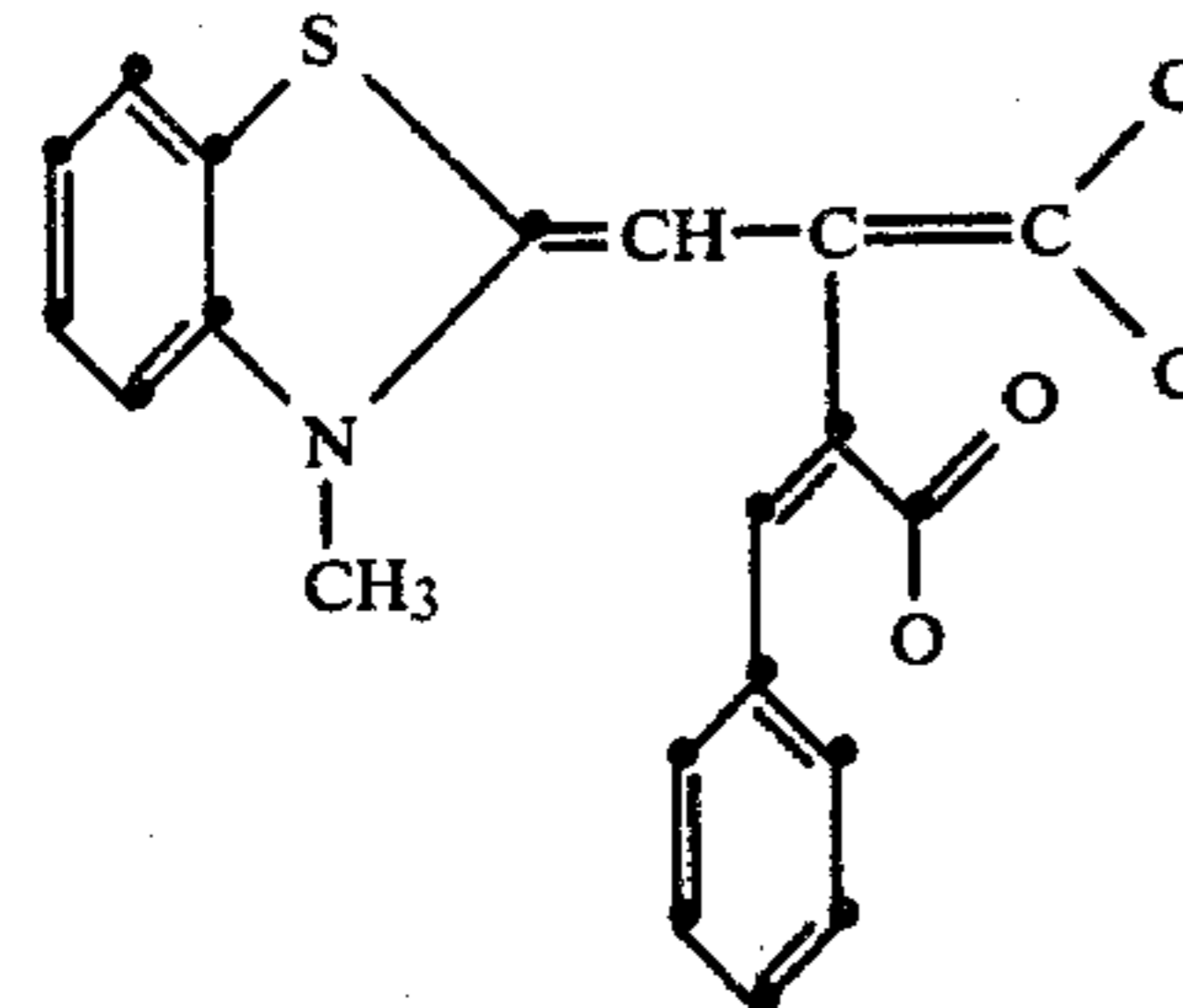
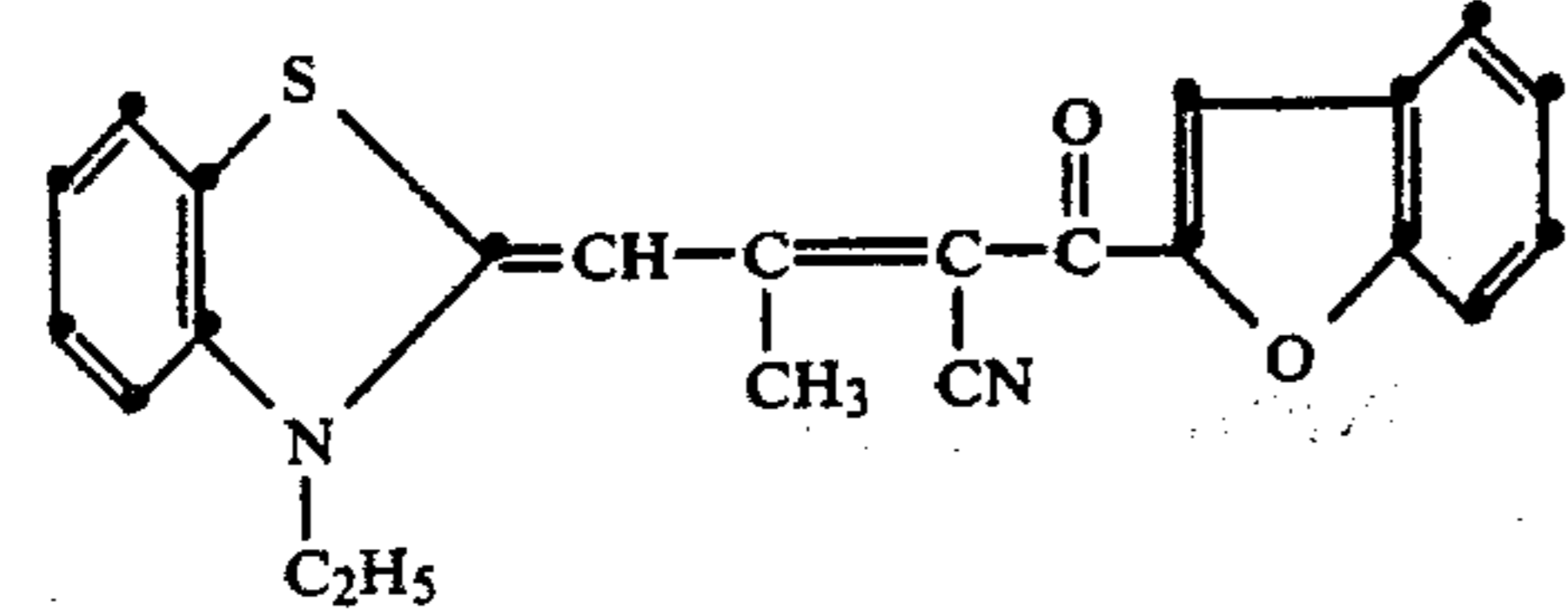
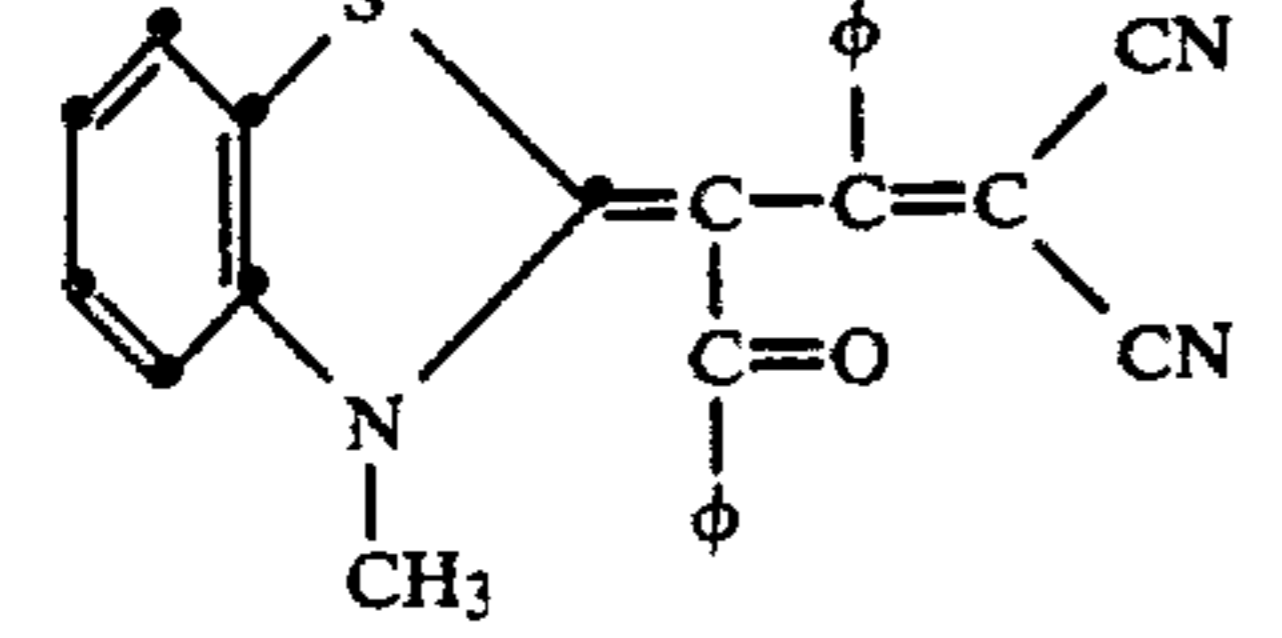
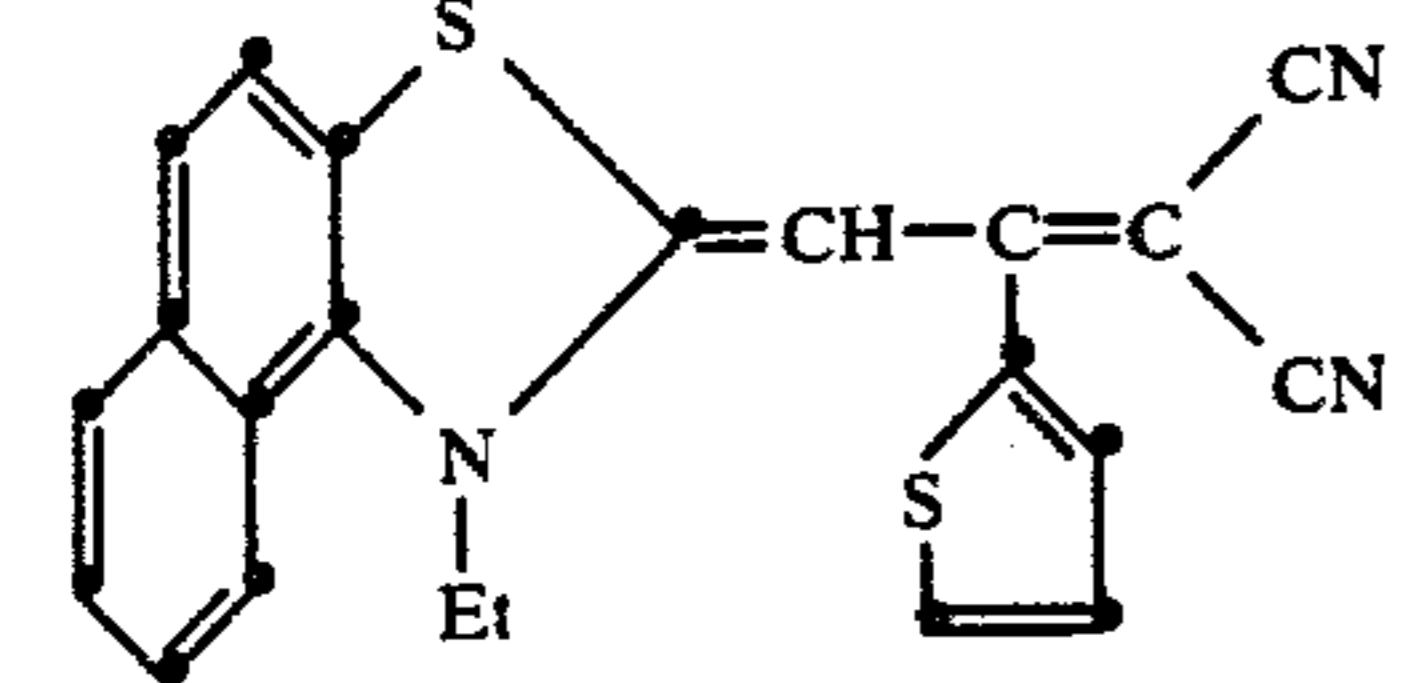
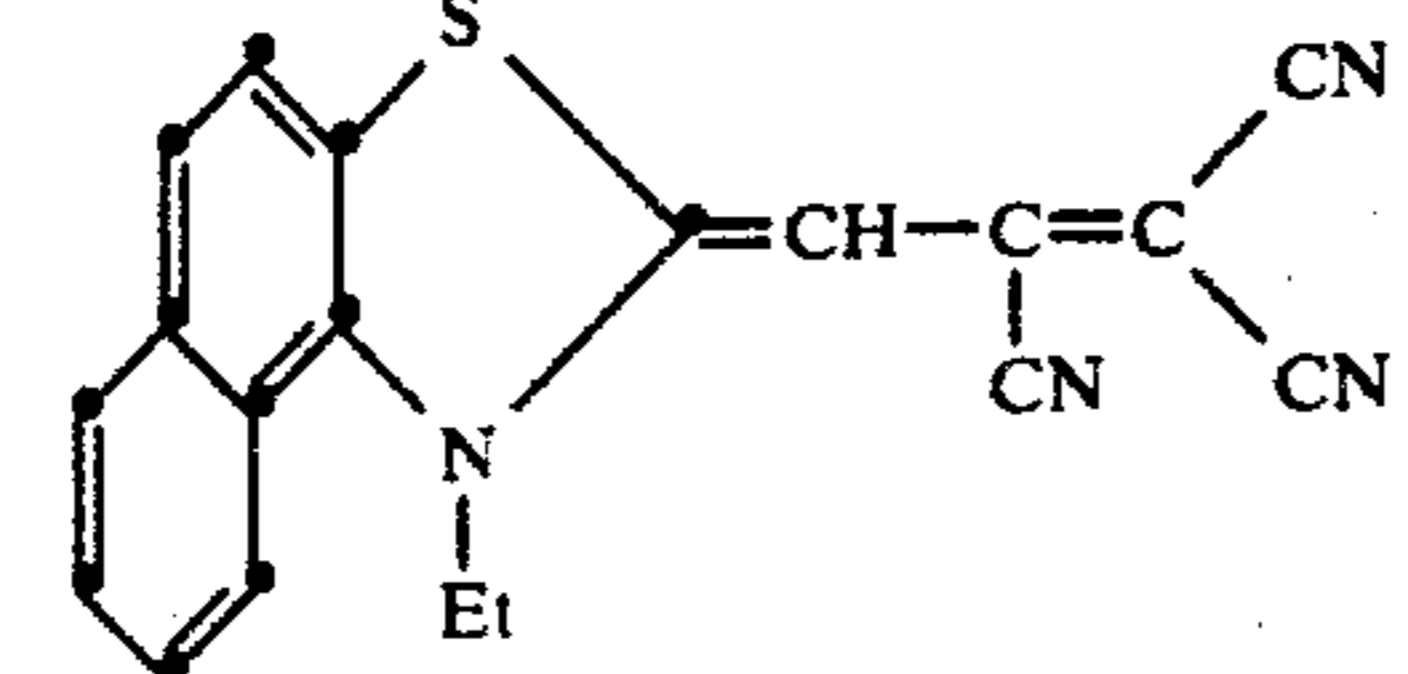
TABLE I-continued.

Number	Material	Color
57		Yellow
58		Yellow

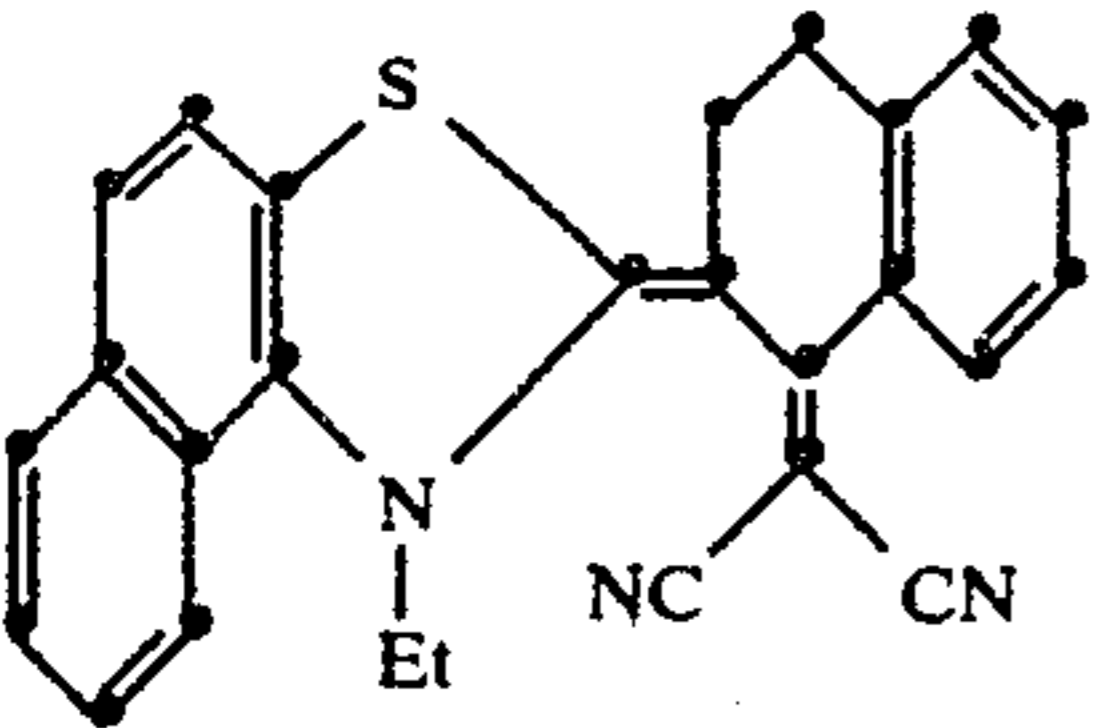
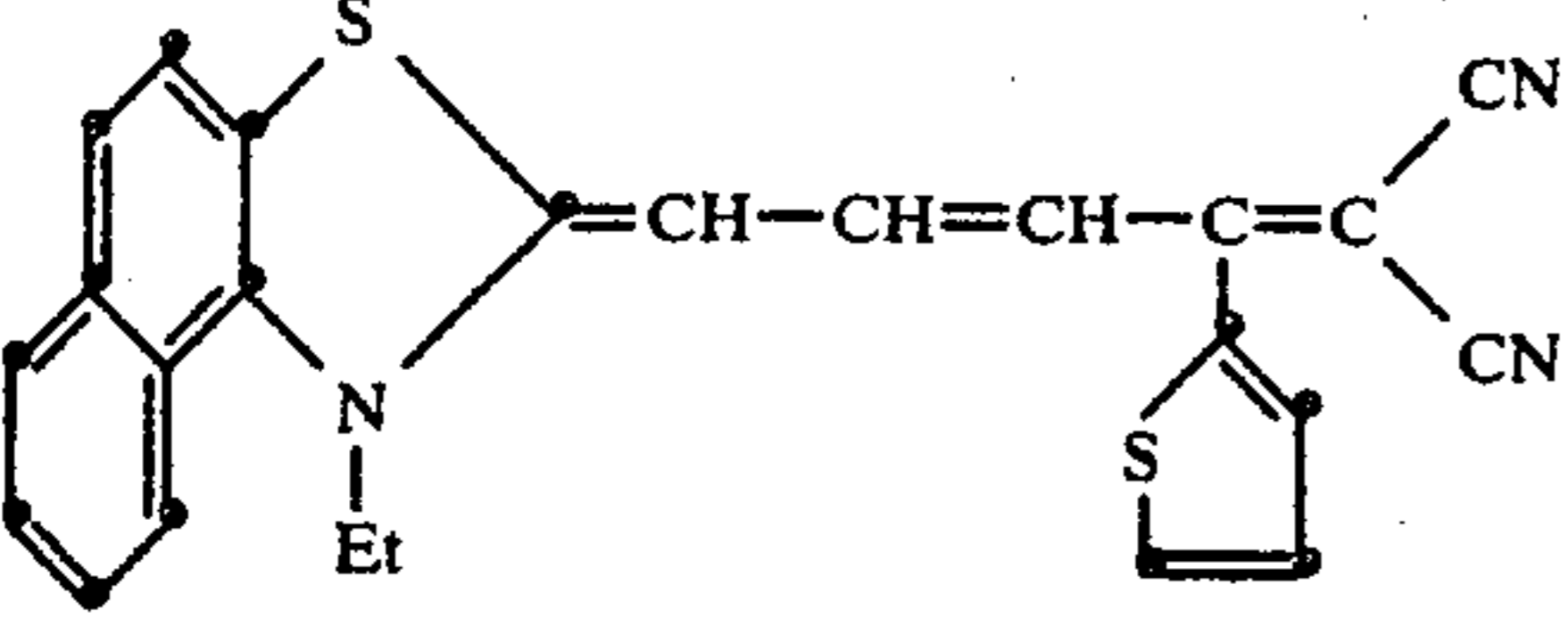
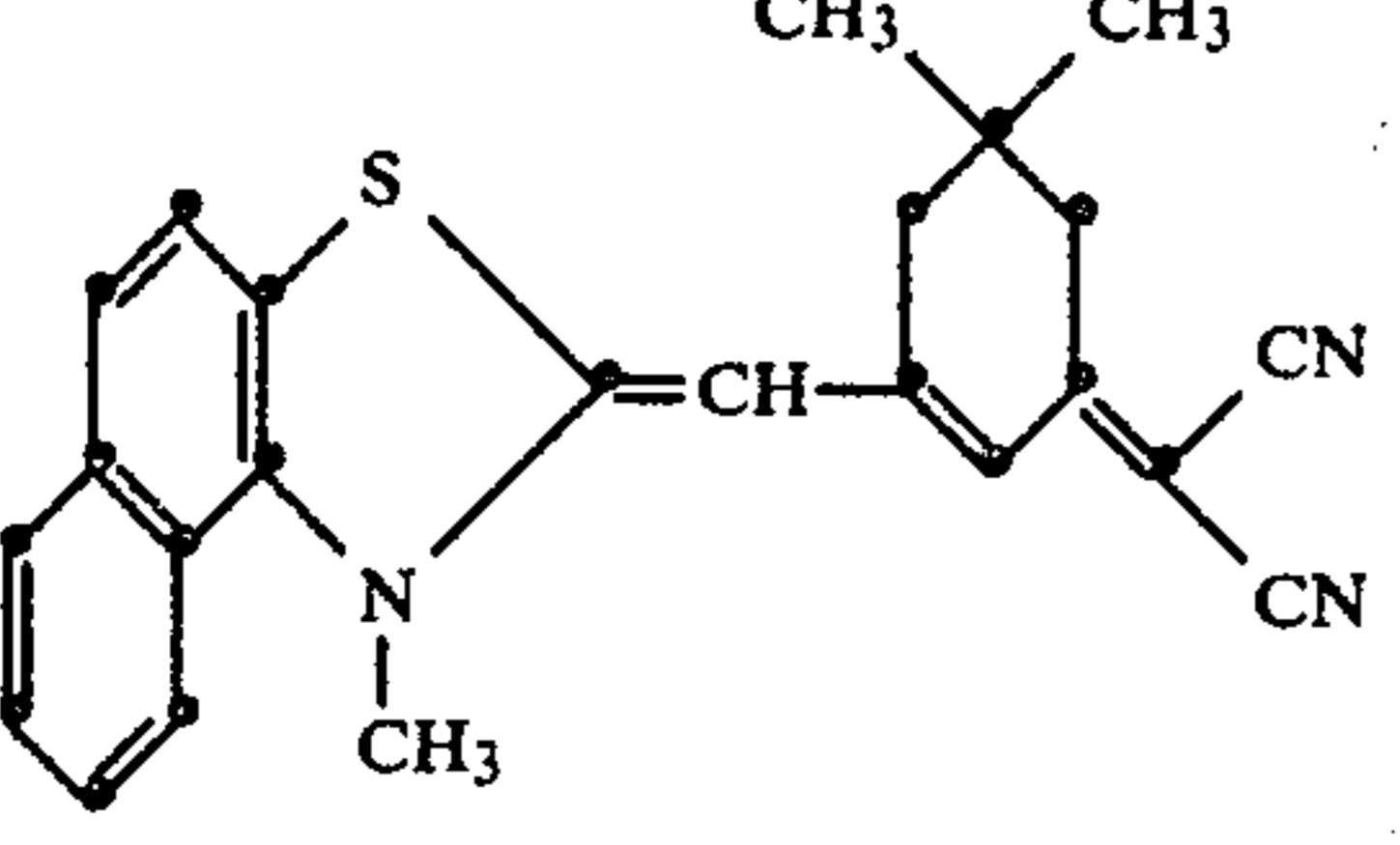
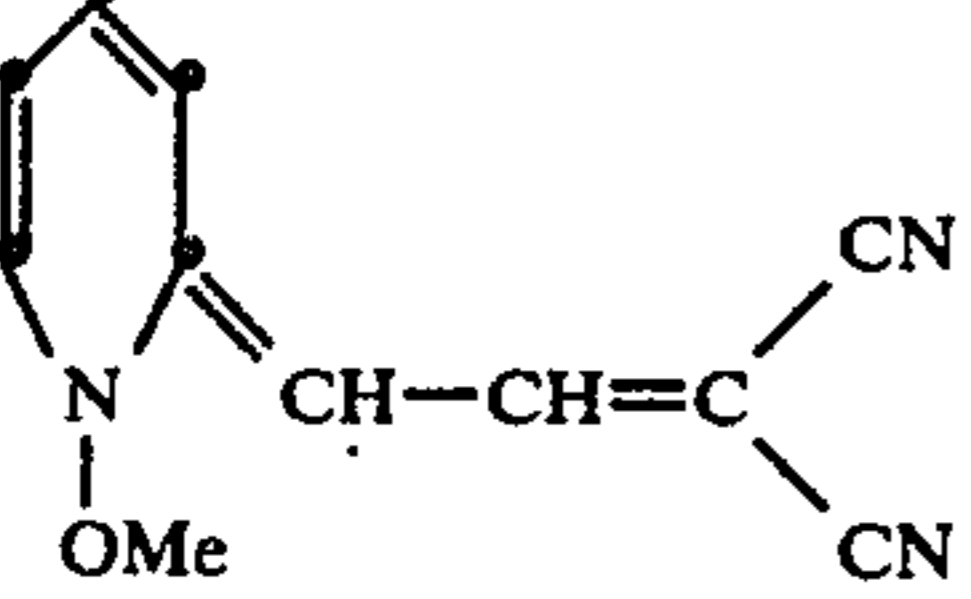
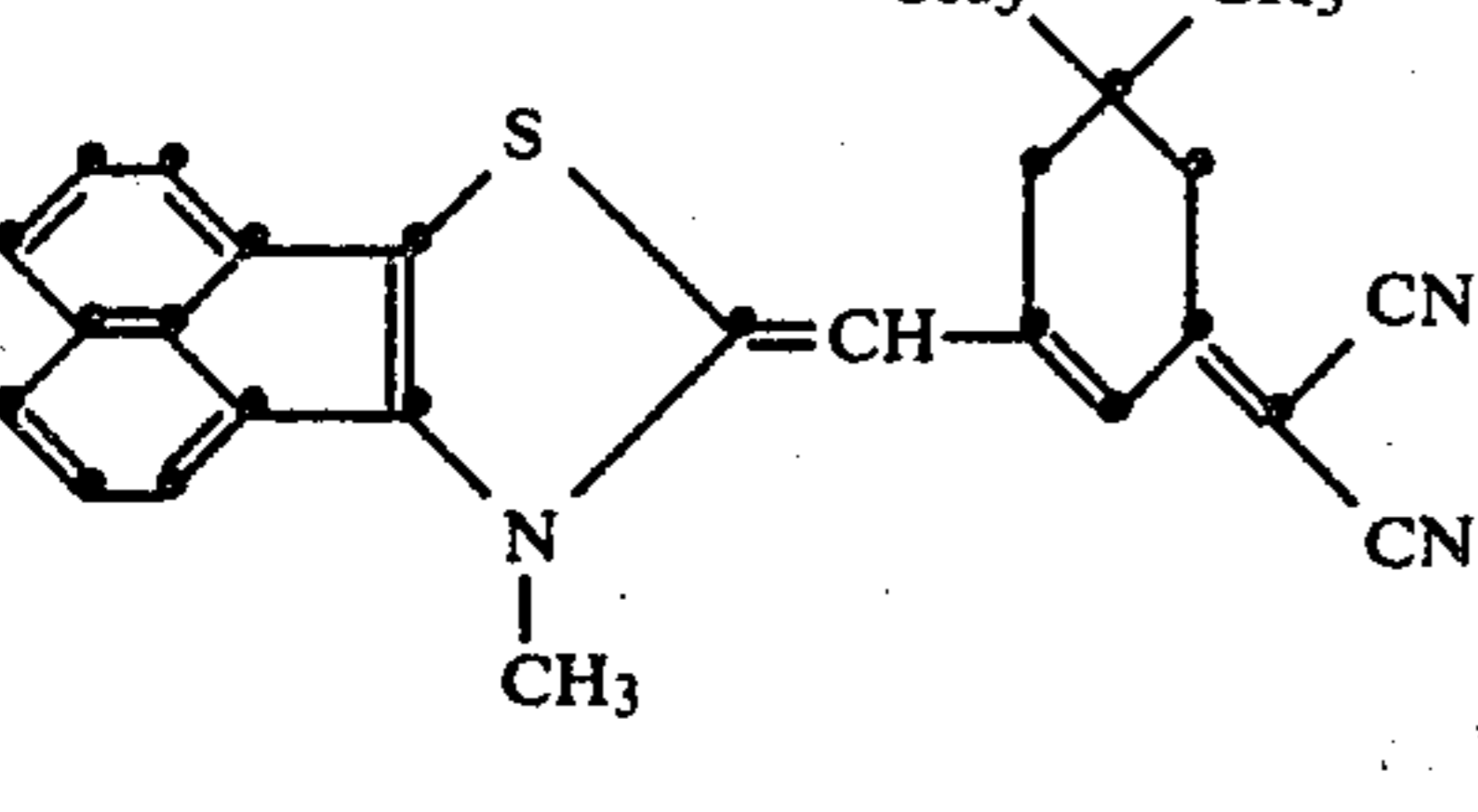
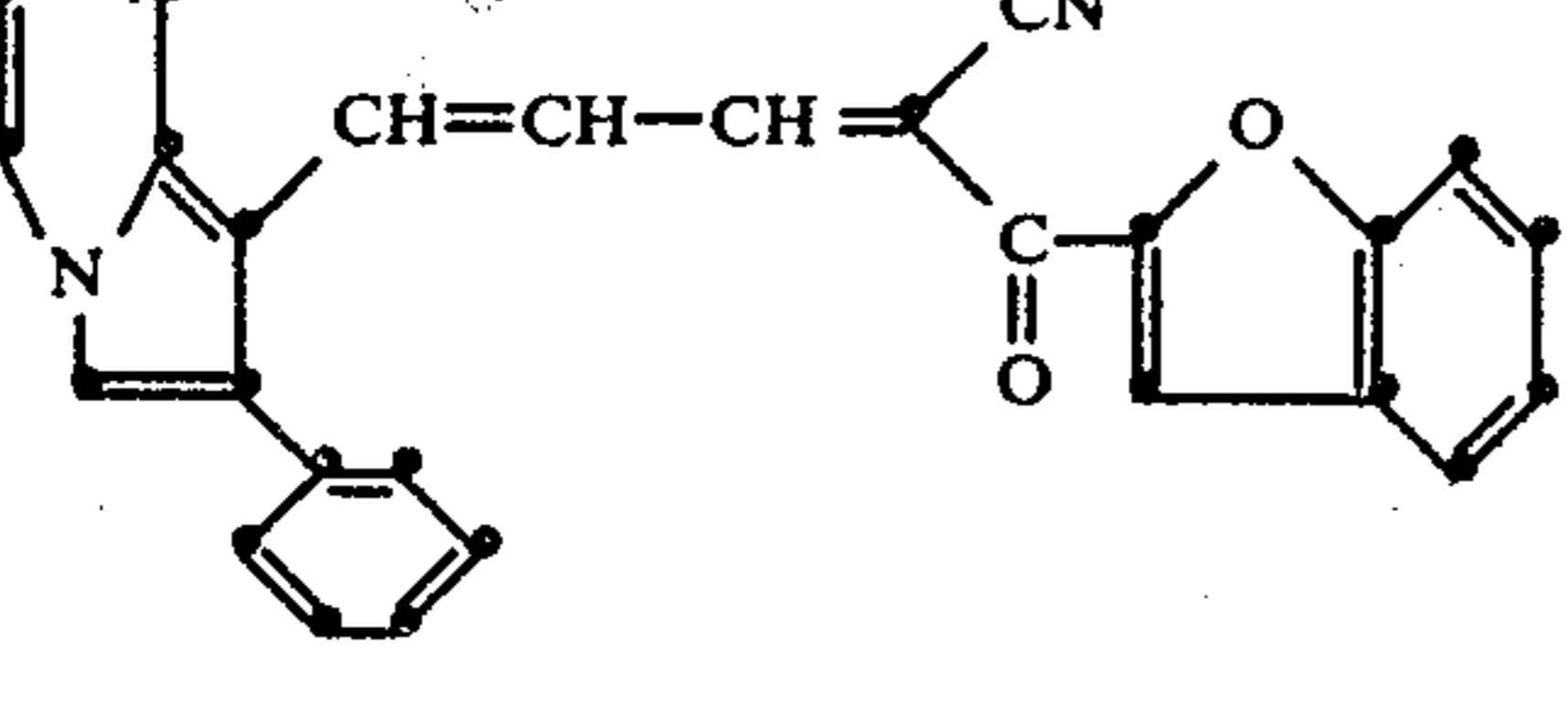
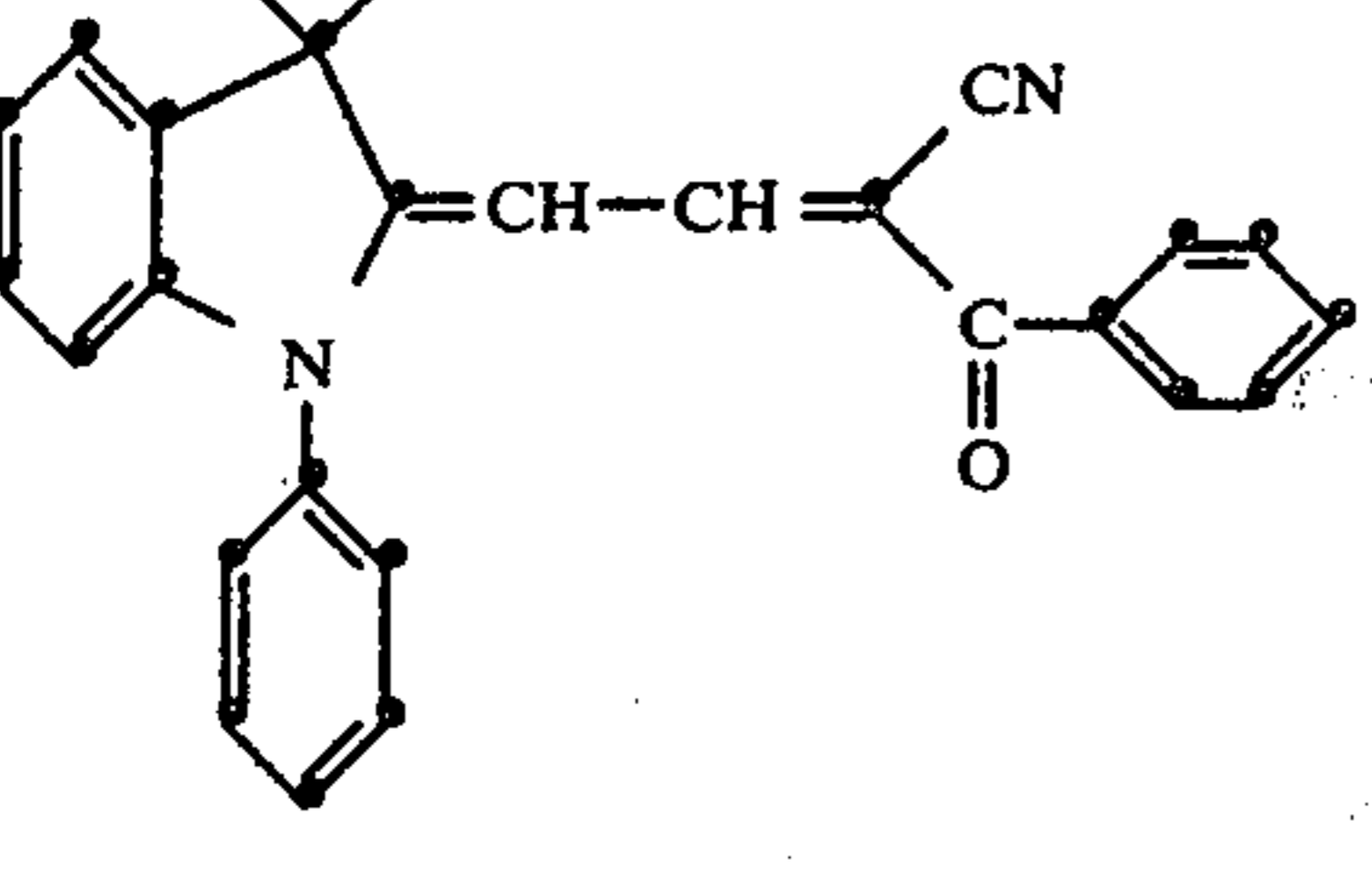
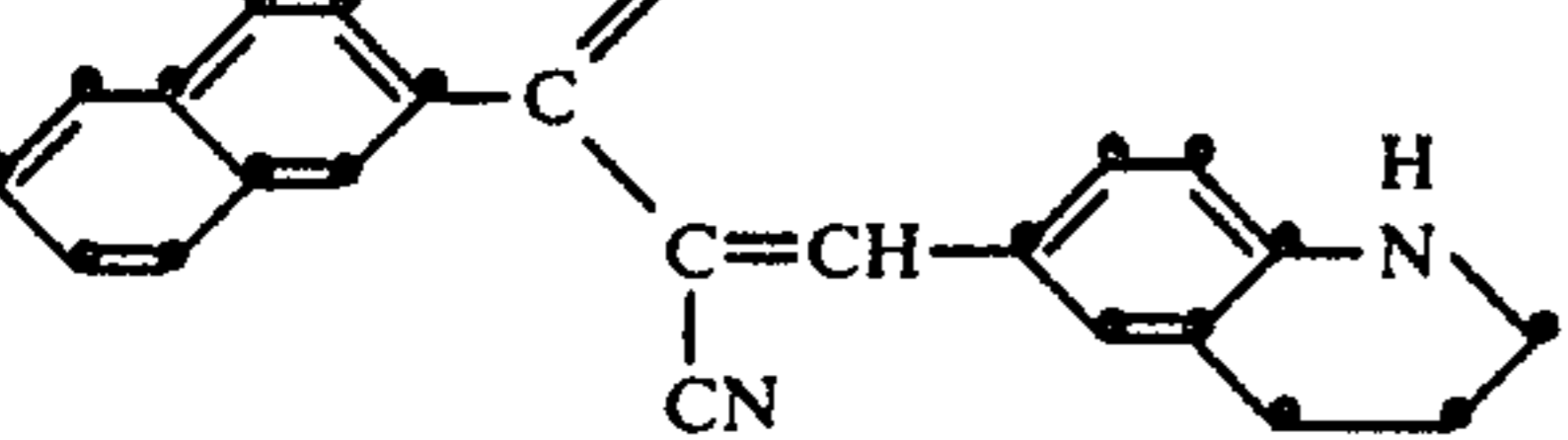
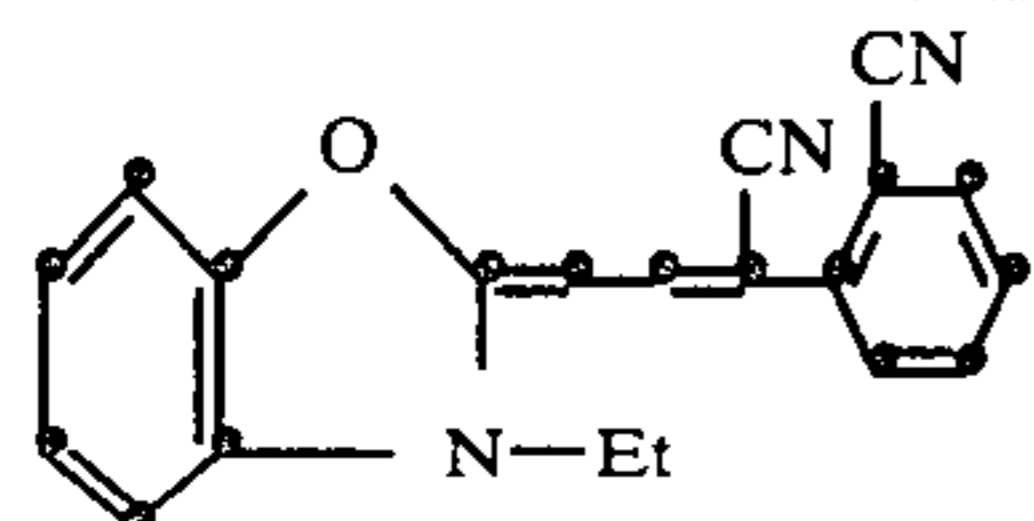
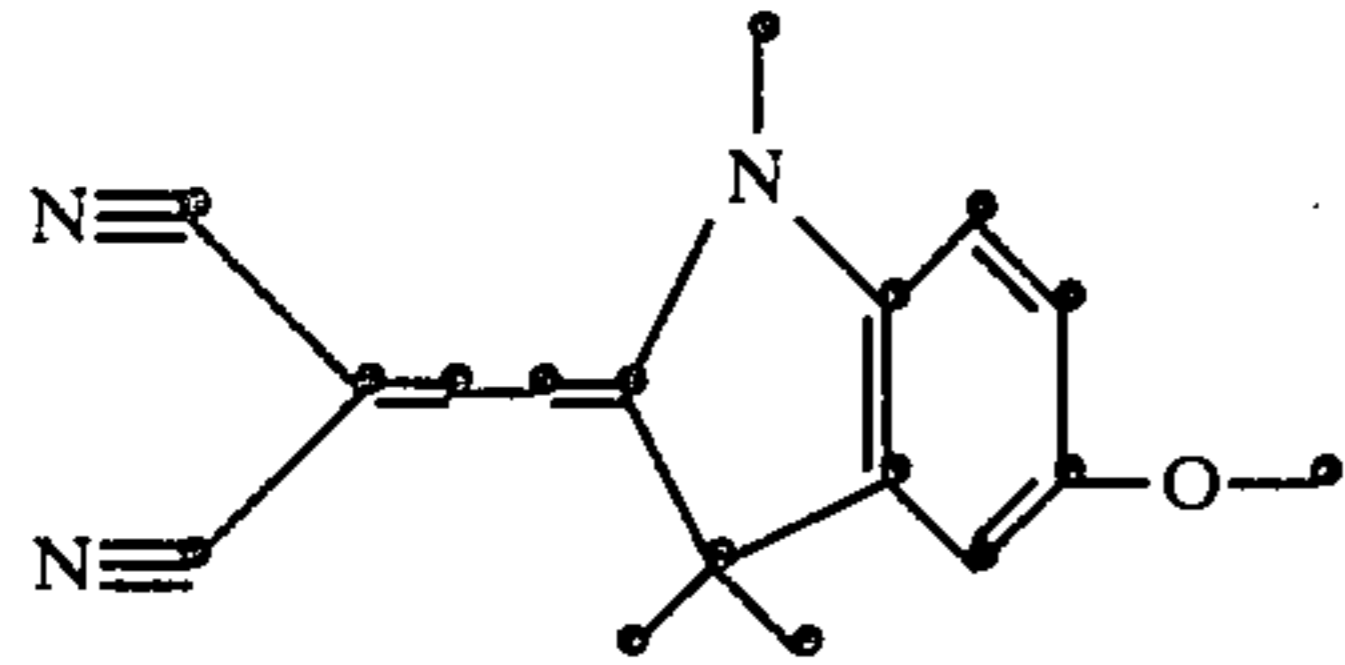
As indicated hereinabove, the electrically photosensitive material described herein is useful in the preparation of the electrically photosensitive imaging particles used in electrophoretic migration imaging processes. In general, electrically photosensitive particles useful in such processes have an average particle size within the range of from about 0.01 micron to about 20 microns, preferably from about 0.01 to about 5 microns. Typically, these particles are composed of one or more colorant materials such as the colorant materials described in the present invention. However, these electrically photosensitive particles may also contain various non-photosensitive materials such as electrically insulating polymers, charge control agents, various organic and inorganic fillers, as well as various additional dyes or pigment materials to change or enhance various colorant and physical properties of the electrically photosensitive particle. In addition, such electrically photosensitive particles may contain other photosensitive materials such as various sensitizing dyes and/or chemical sensitizers to alter or enhance their response characteristics to activating radiation.

When used in an electrophoretic migration imaging process in accord with the present invention, the electrically photosensitive materials described in Table I are typically positioned in particulate form, between two or more spaced electrodes, one or both of which typically being transparent to radiation to which the electrically photosensitive material is light-sensitive, i.e., activating radiation. Although the electrically photosensitive material, in particulate form, may be dispersed simply as a dry powder between two spaced electrodes and then subjected to a typical electrophoretic migration imaging operation such as that described in U.S. Pat. No. 2,758,939 by Sugarman, it is more typical to disperse the electrically photosensitive particulate material in an electrically insulating carrier, such as an electrically insulating liquid, or an electrically insulating, liquefiable matrix material, such as a heat- and/or solvent-softenable polymeric material or a thixotropic polymeric material. Typically, when one employs such a dispersion of electrically photosensitive particulate material and electrically insulating carrier material between the spaced electrodes of an electrophoretic migration imaging system, it is conventional to employ from about 0.05 part to about 2.0 parts of electrically photosensitive particulate material for each 10 parts by weight of electrically insulating carrier material.

As indicated above, when the electrically photosensitive particles used in the present invention are dispersed in an electrically insulating carrier material, such carrier material may assume a variety of physical forms and

may be selected from a variety of different materials. For example, the carrier material may be a matrix of an electrically insulating, normally solid polymeric material capable of being softened or liquefied upon application of heat, solvent, and/or pressure so that the electrically photosensitive particulate material dispersed therein can migrate through the matrix. In another, more typical embodiment of the invention, the carrier material can comprise an electrically insulating liquid such as decane, paraffin, Sohio Odorless Solvent 3440 (a kerosene fraction marketed by the Standard Oil Company, Ohio), various isoparaffinic hydrocarbon liquids such as those sold under the trademark Isopar G by Exxon Corporation and having a boiling point in the range of 145° C. to 186° C., various halogenated hydrocarbons such as carbon tetrachloride, trichloromonofluoromethane, and the like, various alkylated aromatic hydrocarbon liquids such as the alkylated benzenes, for example, xylenes, and other alkylated aromatic hydrocarbons such as are described in U.S. Pat. No. 2,899,335. An example of one such useful alkylated aromatic hydrocarbon liquid which is commercially available is Solvesso 100 made by Exxon Corporation. Solvesso 100 has a boiling point in the range of about 157° C. to about 177° C. and is composed of 9 percent dialkyl benzenes, 37 percent trialkyl benzenes, and 4 percent aliphatics. Typically, whether solid or liquid at normal room temperatures, i.e., about 22° C., the electrically insulating carrier material used in the present invention is a material having a resistivity greater than about 10⁹ ohm-cm, preferably greater than about 10¹² ohm-cm.

When the electrically photosensitive particles formed from the materials of the present invention are incorporated in a carrier material, such as one of the above-described electrically insulating liquids, various other addenda may also be incorporated in the resultant imaging suspension.

For example, various charge control agents may be incorporated in such a suspension to improve the uniformity of charge polarity of the electrically photosensitive particles dispersed in the liquid suspension. Such charge control agents are well known in the field of liquid electrographic developer compositions where they are employed for purposes substantially similar to that described herein. Thus, extensive discussion of the materials herein is deemed unnecessary. These materials are typically polymeric materials incorporated by admixture thereof into the liquid carrier vehicle of the suspension. In addition to, and possibly related to, the aforementioned enhancement of uniform charge polarity, it has been found that the charge control agents

often provide more stable suspensions, i.e., suspensions which exhibit substantially less settling out of the dispersed photosensitive particles.

Useful charge control agents include those disclosed in co-pending U.S. patent application No. 837,779 filed Sept. 29, 1977 by Stahly. The polymeric charge control agents disclosed therein comprise a copolymer having at least two different repeating units.

(a) one of said units being present in an amount of at least about 0.5×10^{-4} moles/gram of said copolymer and being derived from monomers selected from the group consisting of metal salts of sulfoacrylates and methacrylates and metal salts of acrylic and methacrylic acids, and

(b) one of said repeating units being derived from monomers soluble in said carrier vehicle and being present in an amount sufficient to render said copolymer dispersible in said carrier vehicle.

Examples of such copolymer charge control agents are poly(vinyltoluene-co-lauryl methacrylate-co-lithium methacrylate-co-methacrylic acid), poly(styrene-co-lauryl methacrylate-co-lithium sulfoethyl methacrylate), poly(vinyltoluene-co-lauryl methacrylate-co-lithium methacrylate), poly(styrene-co-lauryl methacrylate-co-lithium methacrylate), poly(t-butylstyrene-co-lauryl methacrylate-co-lithium methacrylate), and poly(t-butylstyrene-co-lithium methacrylate).

In addition to the foregoing charge control agent materials, various polymeric binder materials such as various natural, semi-synthetic or synthetic resins, may be dispersed or dissolved in the electrically insulating carrier to serve as a fixing material for the final photosensitive particle image formed on one of the spaced electrodes used in electrophoretic migration imaging systems. Here again, the use of such fixing addenda is conventional and well known in the closely related art of liquid electrographic developer compositions so that extended discussion thereof is unnecessary herein.

The process of the present invention will be described in more detail with reference to the accompanying drawing, FIG. 1, which illustrates a typical apparatus which employs the electrophoretic migration imaging process of the invention.

FIG. 1 shows a transparent electrode 1 supported by two rubber drive rollers 10 capable of imparting a translating motion to electrode 1 in the direction of the arrow. Electrode 1 may be composed of a layer of optically transparent material, such as glass or an electrically insulating, transparent polymeric support such as polyethylene terephthalate, covered with a thin, optically transparent, conductive layer such as tin oxide, indium oxide, nickel, and the like. Optionally, depending upon the particular type of electrophoretic migration imaging process desired, the surface of electrode 1 may bear a "dark charge exchange" material, such as a solid solution of an electrically insulating polymer and 2,4,7-trinitro-9-fluorenone as described by Groner in U.S. Pat. No. 3,976,485 issued Aug. 24, 1976.

Spaced opposite electrode 1 and in pressure contact therewith is a second electrode 5, an idler roller which serves as a counter electrode to electrode 1 for producing the electric field used in the electrophoretic migration imaging process. Typically, electrode 5 has on the surface thereof a thin, electrically insulating layer 6. Electrode 5 is connected to one side of the power source 15 by switch 7. The opposite side of the power source 15 is connected to electrode 1 so that as an exposure takes place, switch 7 is closed and an electric field

is applied to the electrically photosensitive particulate material 4 which is positioned between electrodes 1 and 5. Typically electrically photosensitive particulate material 4 is dispersed in an electrically insulating carrier material such as described hereinabove.

The electrically photosensitive particulate material 4 may be positioned between electrodes 1 and 5 by applying material 4 to either or both of the surfaces of electrodes 1 and 5 prior to the imaging process or by injecting electrically photosensitive imaging material 4 between electrodes 1 and 5 during the electrophoretic migration imaging process.

As shown in FIG. 1, exposure of electrically photosensitive particular material 4 takes place by use of an exposure system consisting of light source 8, an original image 11 to be produced, such as a photographic transparency, a lens system 12, and any necessary or desirable radiation filters 13, such as color filters, whereby electrically photosensitive material 4 is irradiated with a pattern of activating radiation corresponding to original image 11. Although the electrophoretic migration imaging system represented in FIG. 1 shows electrode 1 to be transparent to activating radiation from light source 8, it is possible to irradiate electrically photosensitive particulate material 4 in the nip 21 between electrodes 1 and 5 without either of electrodes 1 or 5 being transparent. In such a system, although not shown in FIG. 1, the exposure source 8 and lens system 12 is arranged so that image material 4 is exposed in the nip or gap 21 between electrodes 1 and 5.

As shown in FIG. 1, electrode 5 is a roller electrode having a conductive core 14 connected to power source 15. The core is in turn covered with a layer of insulating material 6, for example, baryta paper. Insulating material 6 serves to prevent or at least substantially reduce the capability of electrically photosensitive particulate material 4 to undergo a radiation induced charge alteration upon interaction with electrode 5. Hence, the term "blocking electrode" may be used, as is conventional in the art of electrophoretic migration imaging, to refer to electrode 5.

Although electrode 5 is shown as a roller electrode and electrode 1 is shown as essentially a translatable, flat plate electrode in FIG. 1, either or both of these electrodes may assume a variety of different shapes such as a web electrode, rotating drum electrode, plate electrode, and the like as is well known in the field of electrophoretic migration imaging. In general, during a typical electrophoretic migration imaging process wherein electrically photosensitive material 4 is dispersed in an electrically insulating, liquid carrier, electrodes 1 and 5 are spaced such that they are in pressure contact or very close to one another during the electrophoretic migration imaging process, e.g., less than 50 microns apart. However, where electrically photosensitive particulate material 4 is dispersed simply in an air gap between electrodes 1 and 5 or in a carrier such as a layer of heat-softenable or other liquefiable material coated as a separate layer on electrode 1 and/or 5, these electrodes may be spaced more than 50 microns apart during the imaging process.

The strength of the electric field imposed between electrodes 1 and 5 during the electrophoretic migration imaging process of the present invention may vary considerably; however, it has generally been found that optimum image density and resolution are obtained by increasing the field strength to as high a level as possible without causing electrical breakdown of the carrier

medium in the electrode gap. For example, when electrically insulating liquids such as isoparaffinic hydrocarbons are used as the carrier in the imaging apparatus of FIG. 1, the applied voltage across electrodes 1 and 5 typically is within the range of from about 100 volts to about 4 kilovolts or higher.

As explained hereinabove, image formation occurs in electrophoretic migration imaging processes as the result of the combined action of activating radiation and electric field on the electrically photosensitive particulate material 4 disposed between electrodes 1 and 5 in the attached drawing. Typically, for best results, field application and exposure to activating radiation occur concurrently. However, as would be expected, by appropriate selection of various process parameters such as field strength, activating radiation intensity, incorporation of suitable light sensitive addenda in or together with the electrically photosensitive particles formed from the material of Formula I, e.g., by incorporation of a persistent photoconductive material, and the like, it is possible to alter the timing of the exposure and field application events so that one may use sequential exposure and field application events rather than concurrent field application and exposure events.

When disposed between imaging electrodes 1 and 5 of FIG. 1, electrically photosensitive particular material 4 exhibits an electrostatic charge polarity, either as a result of triboelectric interaction of the particles or as a result of the particles interacting with the carrier material in which they are dispersed, for example, an electrically insulating liquid, such as occurs in conventional liquid electrographic developing compositions composed of toner particles which acquire a charge upon being dispersed in an electrically insulating carrier liquid.

Image discrimination occurs in the electrophoretic migration imaging process of the present invention as a result of the combined application of electric field and activating radiation on the electrically photosensitive particulate material dispersed between electrodes 1 and 5 of the apparatus shown in FIG. 1. That is, in a typical imaging operation, upon application of an electric field between electrodes 1 and 5, the particles 4 of charge-bearing, electrically photosensitive material are attracted in the dark to either electrodes 1 or 5, depending upon which of these electrodes has a polarity opposite to that of the original charge polarity acquired by the electrically photosensitive particles. And, upon exposing particles 4 to activating electromagnetic radiation, it is theorized that there occurs neutralization or reversal of the charge polarity associated with either the exposed or unexposed particles. In typical electrophoretic migration imaging systems wherein electrode 1 bears a conductive surface, the exposed, electrically photosensitive particles 4, upon coming into electrical contact with such conductive surface, undergo an alteration (usually a reversal) of their original charge polarity as a result of the combined application of electric field and activating radiation. Alternatively, in the case of photoimmobilized electrophoretic recording (PIER), wherein the surface of electrode 1 bears a dark charge exchange material as described by Groner in aforementioned U.S. Pat. No. 3,976,485, one obtains reversal of the charge polarity of the unexposed particles, while maintaining the original charge polarity of the exposed electrically photosensitive particles, as these particles come into electrical contact with the dark charge exchange surface of electrode 1. In any case, upon the

application of electric field and activating radiation to electrically photosensitive particulate material 4 disposed between electrodes 1 and 5 of the apparatus shown in FIG. 1, one can effectively obtain image discrimination so that an image pattern is formed by the electrically photosensitive particles which corresponds to the original pattern of activating radiation. Typically, using the apparatus shown in FIG. 1, one obtains a visible image on the surface of electrode 1 and a complementary image pattern on the surface of electrode 5.

Subsequent to the application of the electric field and exposure to activating radiation, the images which are formed on the surface of electrodes 1 and/or 5 of the apparatus shown in FIG. 1 may be temporarily or permanently fixed to these electrodes or may be transferred to a final image receiving element. Fixing of the final particle image can be effected by various techniques, for example, by applying a resinous coating over the surface of the image bearing substrate. For example, if electrically photosensitive particles 4 are dispersed in a liquid carrier between electrodes 1 and 5, one may fix the image or images formed on the surface of electrodes 1 and/or 5 incorporating a polymeric binder material in the carrier liquid. Many such binders (which are well known for use in liquid electrographic liquid developers) are known to acquire a charge polarity upon being admixed in a carrier liquid and therefore will, themselves, electrophoretically migrate to the surface of one or the other of the electrodes. Alternatively, a coating of a resinous binder (which has been admixed in the carrier liquid), may be formed on the surfaces of electrodes 1 and/or 5 upon evaporation of the liquid carrier.

The electrically photosensitive colorant material of Formulas I and II may be used to form monochrome images, or the material may be admixed with other electrically photosensitive material of proper color and photosensitivity and use to form polychrome images. Said electrically photosensitive colorant material of the present invention also may be used as a sensitizer for other electrophotosensitive material in the formation of monochrome images. When admixed with other electrically photosensitive materials, selectively the photosensitive material of the present invention may act as a sensitizer and/or as an electrically photosensitive particle. Many of the electrically photosensitive colorant materials having Formulas I and II have especially useful hues which make them particularly suited for use in polychrome imaging processes which employ a mixture of two or more differently colored electrically photosensitive particles. When such a mixture of multicolored electrically photosensitive particles is formed, for example, in an electrically insulating carrier liquid, this liquid mixture of particulate material exhibits a blank coloration. Preferably, the specific cyan, magenta, and yellow particles selected for use in such a polychrome imaging process are chosen so that their spectral response curves do not appreciably overlap whereby color separation and subtractive multicolor image reproduction can be achieved.

The following examples illustrate the utility of the Formulas I and II materials in electrophoretic migration imaging processes.

EXAMPLES 1-59:

Imaging Apparatus

An imaging apparatus was used in each of the following examples to carry out the electrophoretic migration imaging process described herein. This apparatus was a device of the type illustrated in FIG. 1. In this apparatus, a translating film base having a conductive coating of 0.1 optical density cermet (Cr.SiO) served as electrode 1 and was in pressure contact with a 10 centimeter diameter aluminum roller 14 covered with dielectric paper coated with poly(vinyl butyral) resin which served as electrode 5. Plate 1 was supported by two 2.8 cm. diameter rubber drive rollers 10 positioned beneath film plate 1 such that a 2.5 cm. opening, symmetric with the axis of the aluminum roller 14, existed to allow exposure of electrically photosensitive particles 4 to activating radiation. The original transparency 11 to be reproduced was taped to the back side of film plate 1.

The original transparency to be reproduced consisted of adjacent strips of clear (W0), red (W29), green (W61) and blue (W47B) filters. The light source consisted of a Kodak Ektagraphic Av434A Carousel Projector with a 1000 watt Xenon Lamp. The light was modulated with a Kodak No. 5 flexible M-carbon eleven step 0.3 neutral density step tablet. The residence time in the action or exposure zone was 10 milliseconds. The log of the light density (Log I) was as follows:

Filters	Log I erg/cm ² /sec.
W0 Clear	5.34
W29 Red	4.18
W61 Green	4.17
W47B Blue	4.15

The voltage between the electrode 5 and film plate 1 was about 2 kv. Film plate 1 was negative polarity in the case where electrically photosensitive particulate material 4 carried a positive electrostatic charge, and film plate 1 was positive in the case where electrically photosensitive electrostatically charged particles were negatively charged. The translational speed of film plate 1 was about 25 cm. per second. In the following examples, image formation occurs on the surfaces of film plate 1 and electrode 5 after simultaneous application of light exposure and electric field to electrically photosensitive material evaluated for use as electrically photosensitive particulate material 4 was admixed with a liquid carrier as described below to form a liquid dispersion which was placed in nip 21 between the electrodes 1 and 5. If the material being evaluated for use as material 4 possessed a useful level of electrical photosensitivity, one obtained a negative-appearing image reproduction of original 11 on electrode 5 and a complementary image on electrode 1.

Imaging Dispersion Preparation

Imaging dispersions were prepared to evaluate each of the materials in Table I. The dispersions were prepared by first making a stock solution of the following components. The stock solution was prepared simply by combining the components.

Isopar G	2.2 g
Solvesso	1.3 g

-continued

Piccotex 100	1.4 g
PVT*	0.1 g

*Poly(vinyltoluene-co-lauryl methacrylate-co-lithium methacrylate-co-methacrylic acid) 56/40/3.6/0.4

A 5 g. aliquot of the stock solution was combined in a closed container with 0.045 g. of the Table I material to be tested and 12 g. of Hamber 440 stainless steel balls. The preparation was then milled for three hours on a paint shaker.

Each of the 59 materials described in Table I was tested according to the just outlined procedures. Each of such materials was found to be electrophotosensitive as evidenced by obtaining a negative appearing image of the original on one electrode and a complementary image on the other electrode. Materials 3, 15, 16, 27, 29, 39, 42, 43, 44 and 47 provide images having good to excellent quality. Image quality was determined visually having regard to minimum and maximum densities, speed and color saturation.

EXAMPLES 60-77

Imaging dispersions containing the Table I materials listed in Table II were prepared as in the previous Examples 1-59. Imaging was also carried out as in the previous examples except the polymeric coating on the receiver element was either Polymer A and Polymer B as indicated in Table II.

A portion of the imaged polymer receiver element for each Table II material was heated at 170° C. for 15 seconds. The sample generally changed to a brighter hue when heated in the polymer coating. Reflection spectra were taken of both the unheated and heated samples using diffuse illumination. Results are reported in Table II.

TABLE II

Table I Material	λ_{max}^*	% Density Change**	λ_{max} in Polymer A or B***
3	575	51	544(A)
25	450	117	560(A)
39	566	59	536(A)
43	635	67	585(A)
47	536	105	509(A)
33	456	234	456(A)
24	552	37	554(A)
5	588	238	563(A)
26	590	888	553(A)
41	554	618	550(B)
27	541	361	537(A)
15	666	42	613(A)
48	549	66	524(A)
40	620	5	589(B)
18	560	14	565(B)
7	510	533	515(B)
23	658	10	652(B)
8	560	38	561(B)

*Wavelength of maximum absorption for unheated crystalline dyes.

**Percent increase in optical density (color reflection measured through appropriate filters) between heated and unheated images.

***Wavelength of maximum absorption for heated dye in polymer A or Polymer B. Polymer A is a poly(vinylbutyral) resin under the tradename Butvar B76® from Shawinigan Products Corp. Polymer B is ethyleneglycol/cyclohexane dimethanol/terephthalic acid copolyester (70:30).

The invention has been described in detail with particular reference to certain preferred embodiments thereof, but it will be understood that variations and modifications can be effected within the spirit and scope of the invention.

We claim:

1. An electrophoretic migration image comprising a material having the structure:

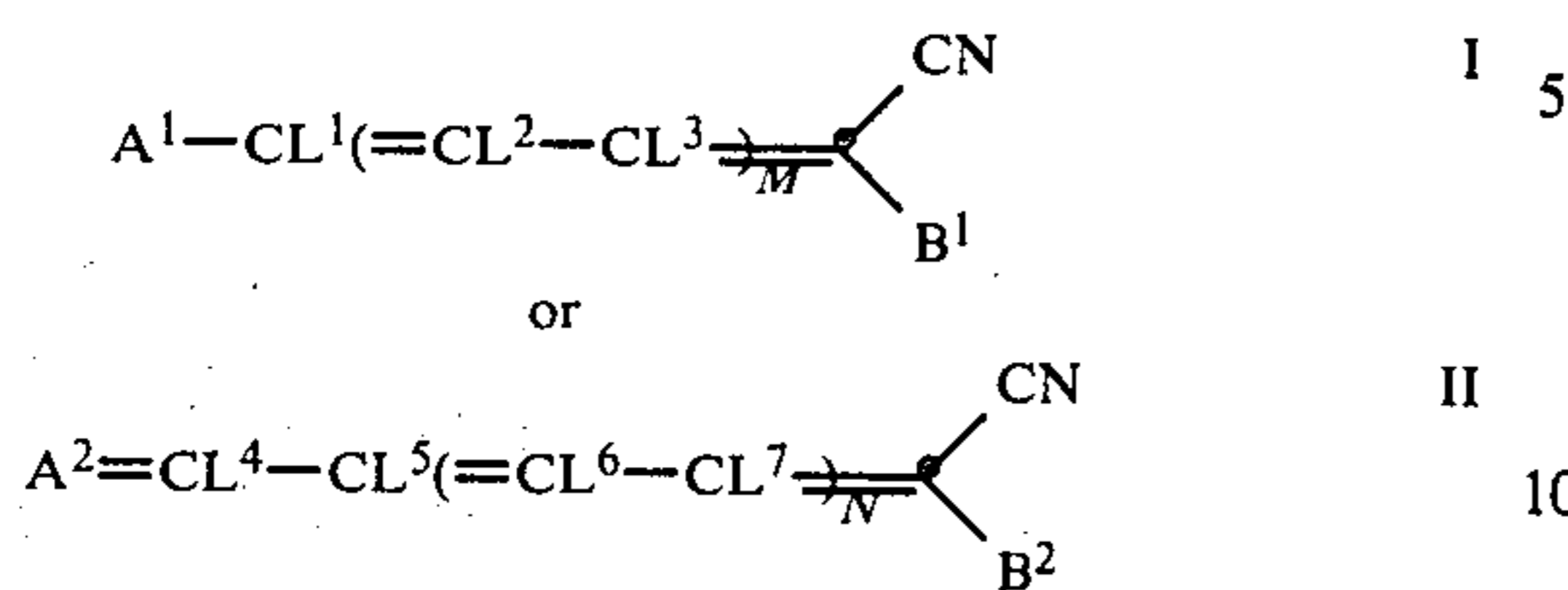

wherein:

M and N may be zero, one or two;

L¹, L², L³, L⁴, L⁵, L⁶ and L⁷ may be cyano, hydrogen, substituted or unsubstituted alkyl, alkoxy, aralkyl, aryl or heterocycyl and in addition any two of L¹, L² and L³ and any two of L⁴, L⁵, L⁶ and L⁷ may together represent the elements needed to complete a carbocyclic or heterocyclic ring having from 5-12 carbon atoms;

A¹ may be the same as A² and in addition may represent an aryl or diarylamino aryl substituted, or unsubstituted aryl group or a substituted or unsubstituted heterocyclic nucleus such as thiophene, benzo[b]thiophene, naphtho[2,3-b]thiophene, furan, isobenzofuran, chromene, pyran, xanthene, pyrrole, 2H-pyrrole, pyrazole, indolizine, indoline, indole, indazole, carbazole, pyrimidine, isothiazole, isoxazole, furazan, chroman, isochroman, 1,2,3,4-tetrahydroquinoline, 1,2-dihydro-4H-pyrrolo[3,2,1-ij]quinoline; 4H-pyrrolo[3,2,1-ij]quinoline; 1,2,5,6-tetrahydro-4H-pyrrolo[3,2,1-ij]quinoline; 1H,5H-benzo[ij]quinolizine; 2,3-dihydro-1H,5H-benzo[ij]quinolizine; 2,3-dihydro-1H,5H-benzo[ij]-quinolizine and 2,3,6,7-tetrahydro-1H,5H-benzo[ij]quinolizine; 10,11-dihydro-9H-benzo[a]xanthen-8-yl; 6,7-dihydro-5H-benzo[b]pyran-7-yl and pyrrolo[2,1-b]-benzothiazole;

A² represents a basic substituted or unsubstituted heterocyclic nucleus selected from the group consisting of substituted or unsubstituted imidazole, thiazole, benzothiazole, naphthothiazole, thianaphtho-7',6',4,5-thiazole, oxazole, benzoxazole, naphthoxazole, benzoselenazole, naphthoselenazole, thiazoline, 2-quinoline, 4-quinoline, 1-isoquinoline, benzimidazole, 2-pyridine, 4-pyridine, pyrrolo[1,2-a]pyridine, 3H-indole, tetrazole, and acenaphthothiazole; and

B¹ and B² represent cyano, cyanoaryl, carboxy, alkoxycarbonyl, aryloxycarbonyl, alkylsulfonyl, acyl, arylcarbonyl, benzofuroyl, nitro, nitro-substituted aryl, sulfonyl, fluorosulfonyl, trifluoromethylsulfonyl, carbamoyl, arylcarbamoyl, and alkylcarbamoyl, or

B² may be combined with =CL⁴-CL⁵= or =CL⁶-CL⁷= to provide sufficient atoms to form a substituted pyridine nucleus.

2. An electrophotosensitive dispersion for use in an electrophoretic migration imaging process, said dispersion comprising an electrophotosensitive material a charge control agent and an electrically insulating carrier, characterized in that at least a portion of said electrophotosensitive material has the structure:

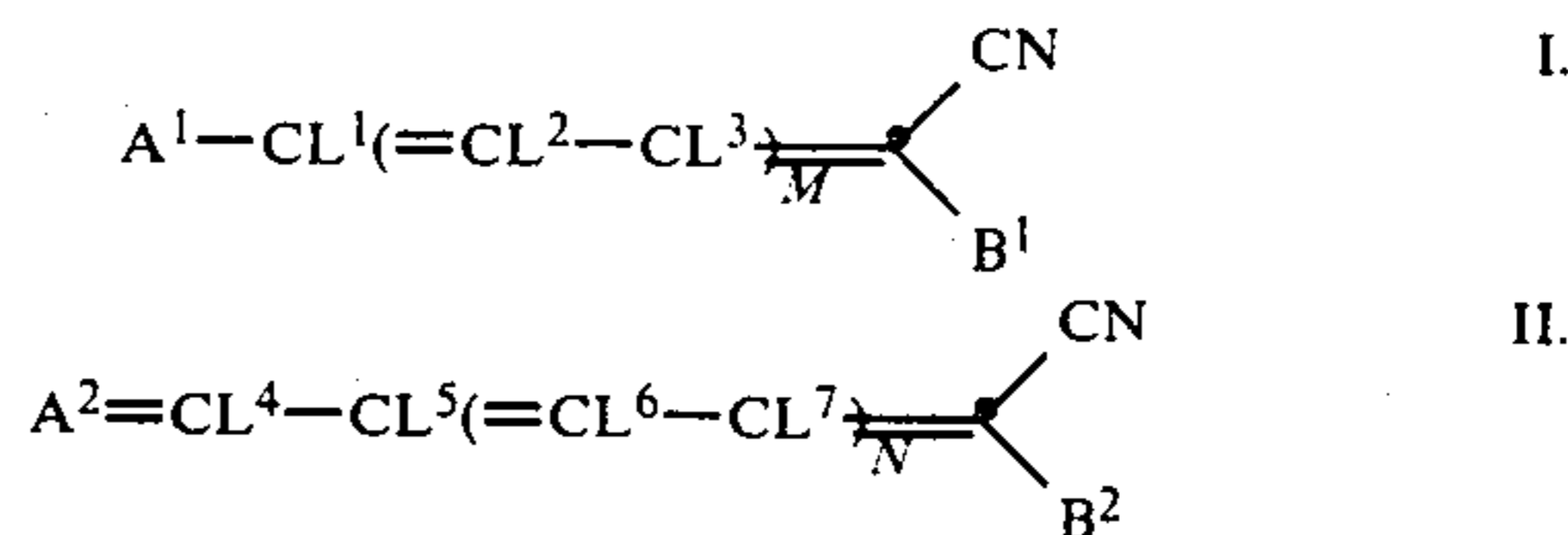

wherein:

M and N may be zero, one or two;

L¹, L², L³, L⁴, L⁵, L⁶, and L⁷ may be cyano, hydrogen, substituted or unsubstituted alkyl, alkoxy, aralkyl, aryl or heterocycyl and in addition any two of L¹, L² and L³ and any two of L⁴, L⁵, L⁶ and L⁷ may together represent the elements needed to complete a carbocyclic or heterocyclic ring having from 5-12 carbon atoms;

A¹ may be the same as A² and in addition may represent an aryl or diarylamino substituted, or unsubstituted aryl group or a substituted or unsubstituted heterocyclic nucleus such as thiophene, benzo[b]thiophene, naphtho[2,3-b]thiophene, furan, isobenzofuran, chromene, pyran, xanthene, pyrrole, 2H-pyrrole, pyrazole, indolizine, indoline, indole, indazole, carbazole, pyrimidine, isothiazole, isoxazole, furazan, chroman, isochroman, 1,2,3,4-tetrahydroquinoline; 4H-pyrrolo[3,2,1-ij]quinoline; 1,2-dihydro-4H-pyrrolo[3,2,1-ij]quinoline; 1,2,5,6-tetrahydro-4H-pyrrolo[3,2,1-ij]quinoline; 1H,5H-benzo[ij]quinolizine; 2,3-dihydro-1H,5H-benzo[ij]quinolizine; 2,3-dihydro-1H,5H-benzo[ij]quinolizine, and 2,3,6,7-tetrahydro-1H,5H-benzo[ij]quinolizine; 10,11-dihydro-9H-benzo[a]xanthen-8-yl; 6,7-dihydro-5H-benzo[b]pyran-7-yl and pyrrolo[2,1-b]benzothiazole;

A² represents a basic substituted or unsubstituted heterocyclic nucleus selected from the group consisting of substituted or unsubstituted imidazole, thiazole, benzothiazole, naphthothiazole, thianaphtho-7',6',4,5-thiazole, oxazole, benzoxazole, naphthoxazole, benzoselenazole, naphthoselenazole, thiazoline, 2-quinoline, 4-quinoline, 1-isoquinoline, benzimidazole, 2-pyridine, 4-pyridine, pyrrolo[1,2-a]pyridine, 3H-indole, tetrazole, and acenaphthothiazole; and

B¹ and B² represent cyano, cyanoaryl, carboxy, alkoxycarbonyl, aryloxycarbonyl, alkylsulfonyl, acyl, arylcarbonyl, benzofuroyl, nitro, nitro substituted aryl, sulfonyl, fluorosulfonyl, trifluoromethylsulfonyl, carbamoyl, arylcarbamoyl, and alkylcarbamoyl or

B² may be combined with $\text{=CL}^4\text{-CL}^5\text{=}$ or $\text{=CL}^6\text{-CL}^7\text{=}$ to provide sufficient atoms to form a substituted pyridine nucleus.

3. A dispersion according to claim 2 wherein said carrier is a liquid.

4. A dispersion according to claim 2 wherein A¹ represents a substituted or unsubstituted nucleus selected from the group consisting of indole; 1,2,5,6-tetrahydro-4H-pyrrolo-[3,2,1,-ij]quinoline; 2,3,6,7-tetrahydro-1H,5H-benzo[ij]quinolizine; pyrrolo[2,1-b]benzothiazole and ditolylaminophenyl;

A² represents a substituted and unsubstituted nucleus selected from the group consisting of 3H-indole, benzothiazole, naphthothiazole, benzimidazole, 2-pyridine, pyrrolo[1,2-a]pyridine and benzoxazole, benzoselenazole and acenaphthothiazole;

L¹, L², L³, L⁴, L⁵, L⁶, and L⁷ which may be the same or different represent hydrogen, cyano, methyl, methoxy, ethyl, ethoxy, phenyl, benzoyl, 2-thienyl, benzofuryl, 3-dicyanomethylenebutyl, 2-oxo-2H-benzo[b]pyran-3-yl, and 2-hydroxyphenyl-1-carboxyethenyl or any two of L¹, L², and L³ or L⁴, L⁵, L⁶, and L⁷ may represent the atoms needed to complete a nucleus selected from the group consisting of dihydronaphthalene, 1H-indene, acenaphthalene, pyrimidine-dione and cyclohexene; and

B¹ and B² represent cyano, cyanophenyl, ethoxycarbonyl, naphthoyl, benzoyl; furoyl, and dihydroxybenzoyl; or

B² may be combined with $\langle \text{CL}^6 \text{--} \text{CL}^7 \rangle$ or $\langle \text{CL}^4 \text{--} \text{CL}^5 \rangle$ to provide sufficient atoms to form a substituted pyridine nucleus.

5. A dispersion according to claim 2 wherein at least a portion of said electrophotosensitive material is selected from the group consisting of:

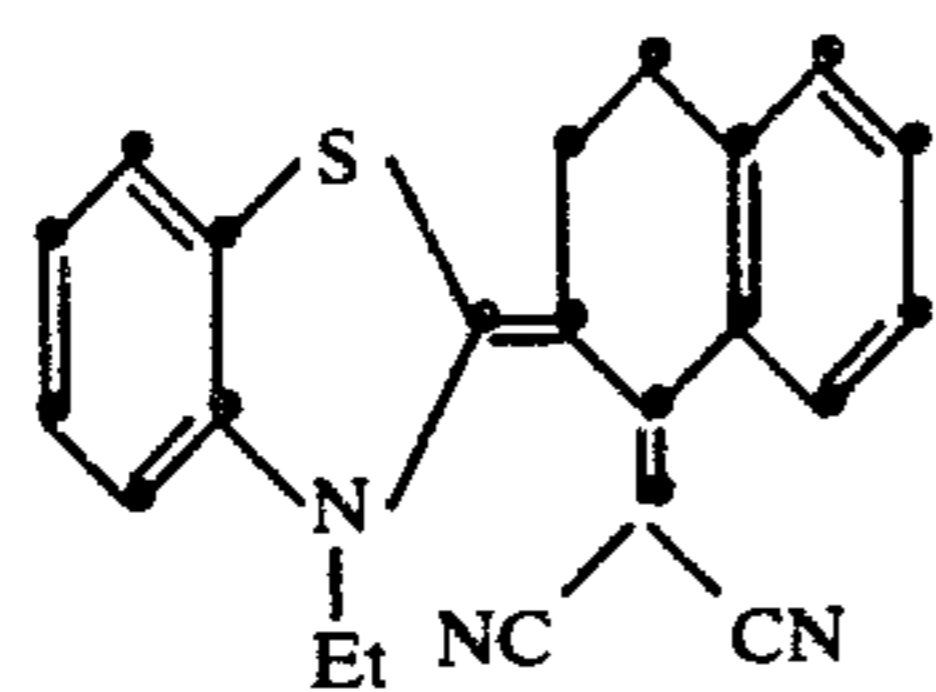
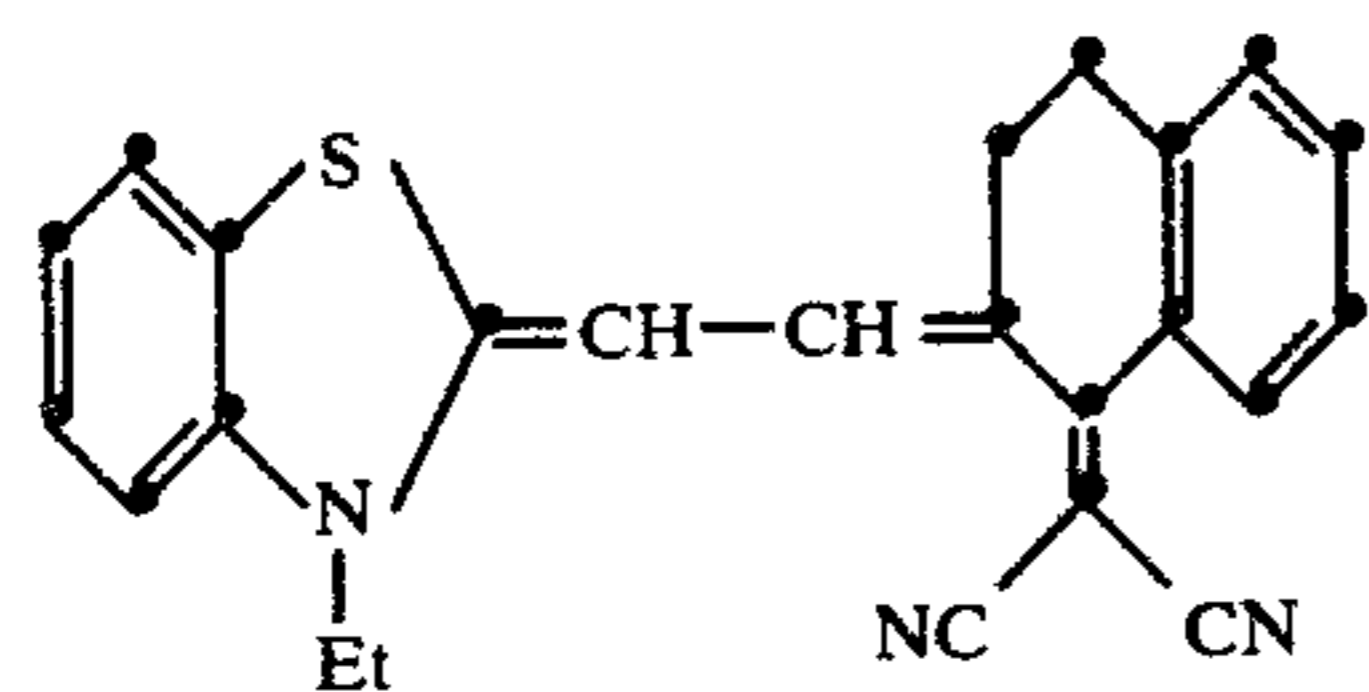
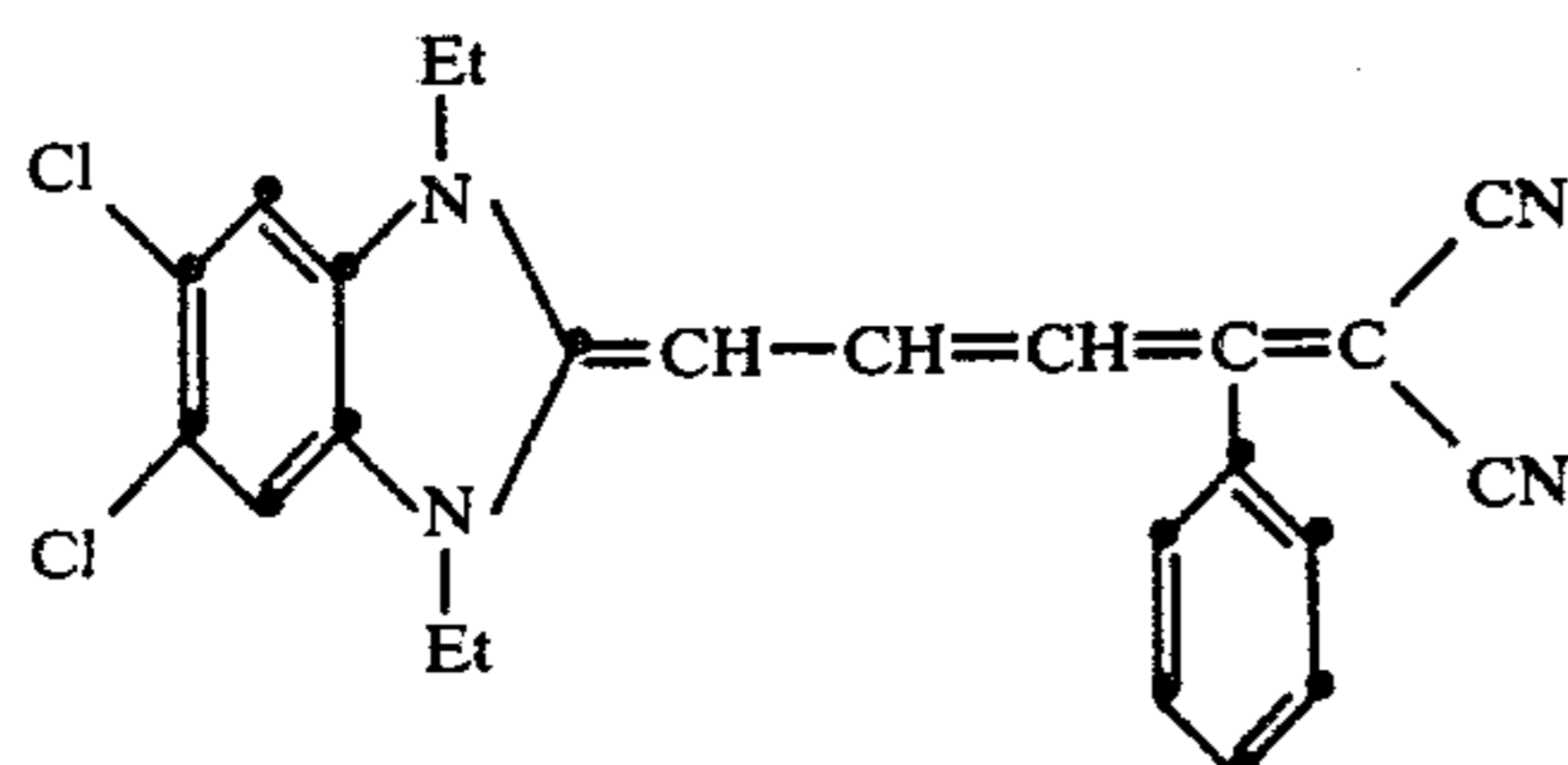

-continued

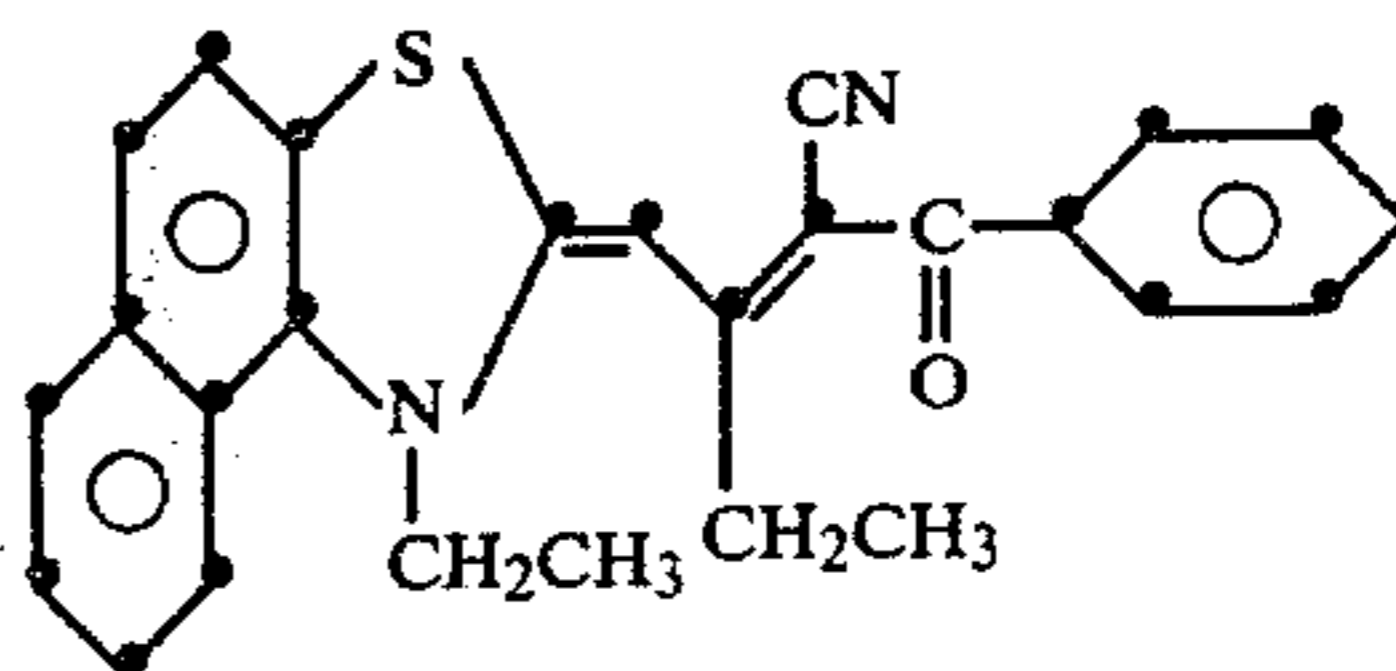
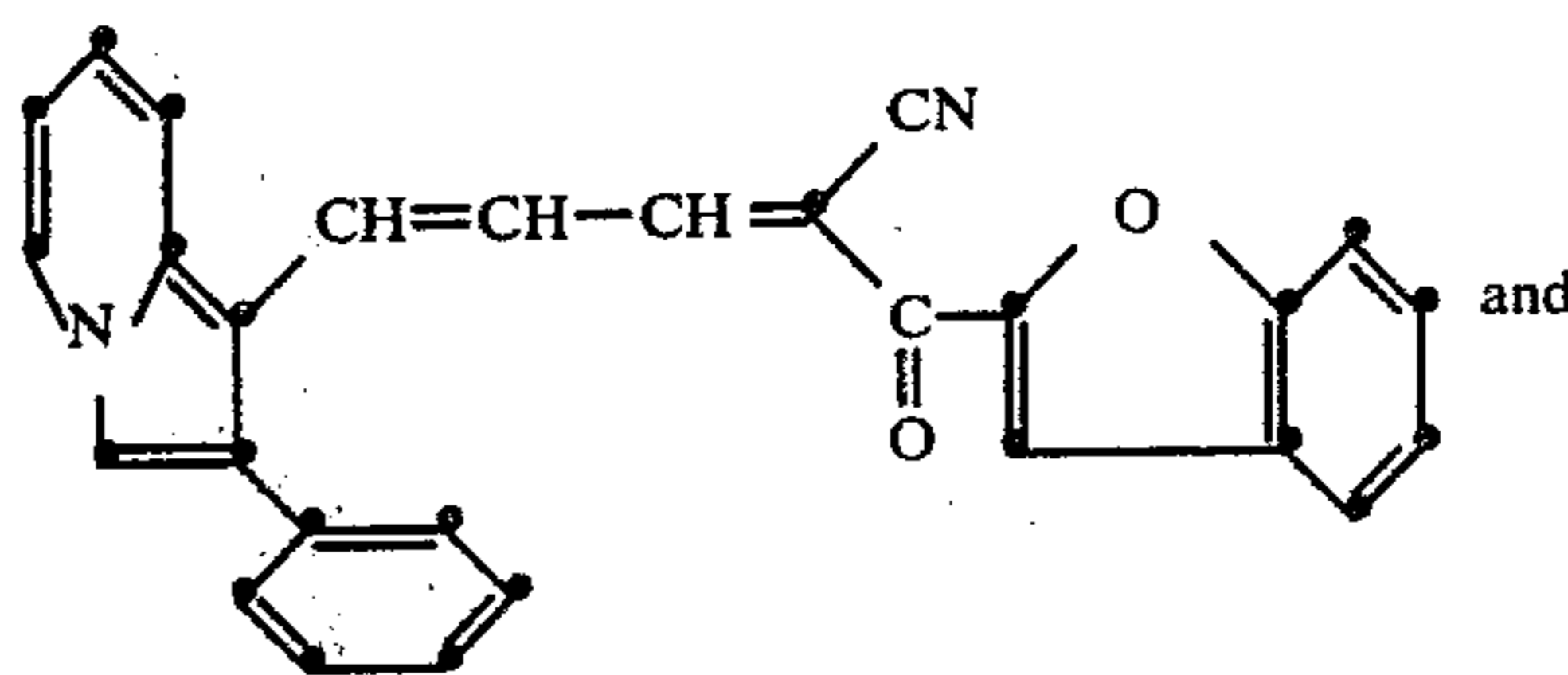
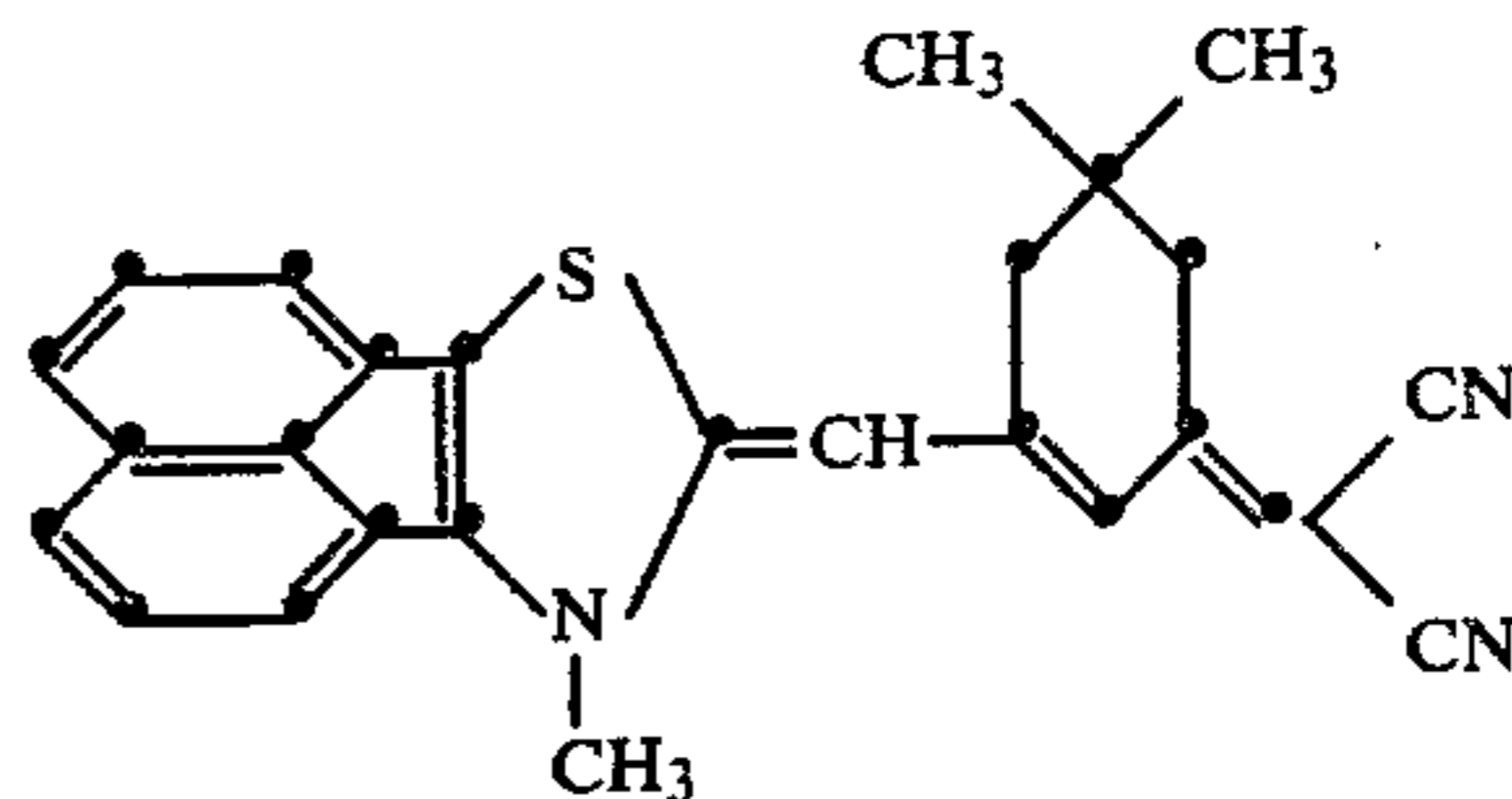
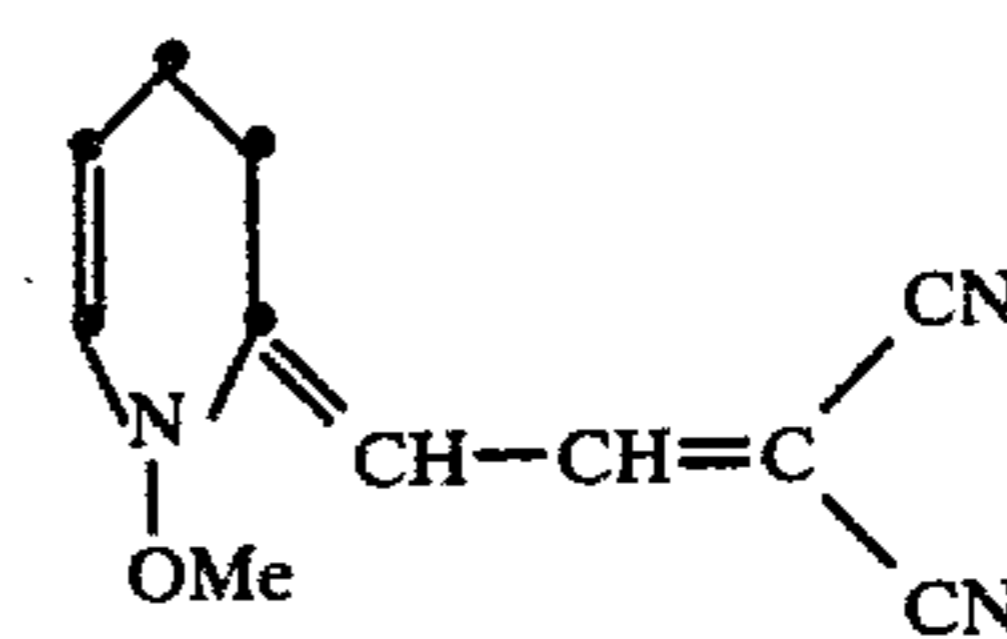
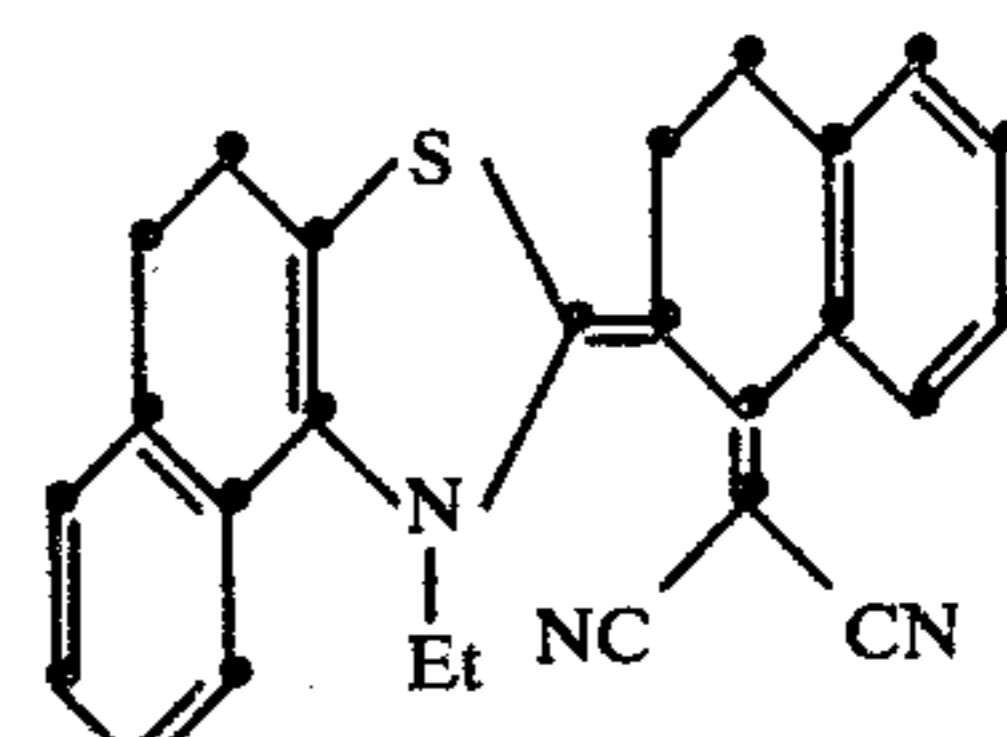
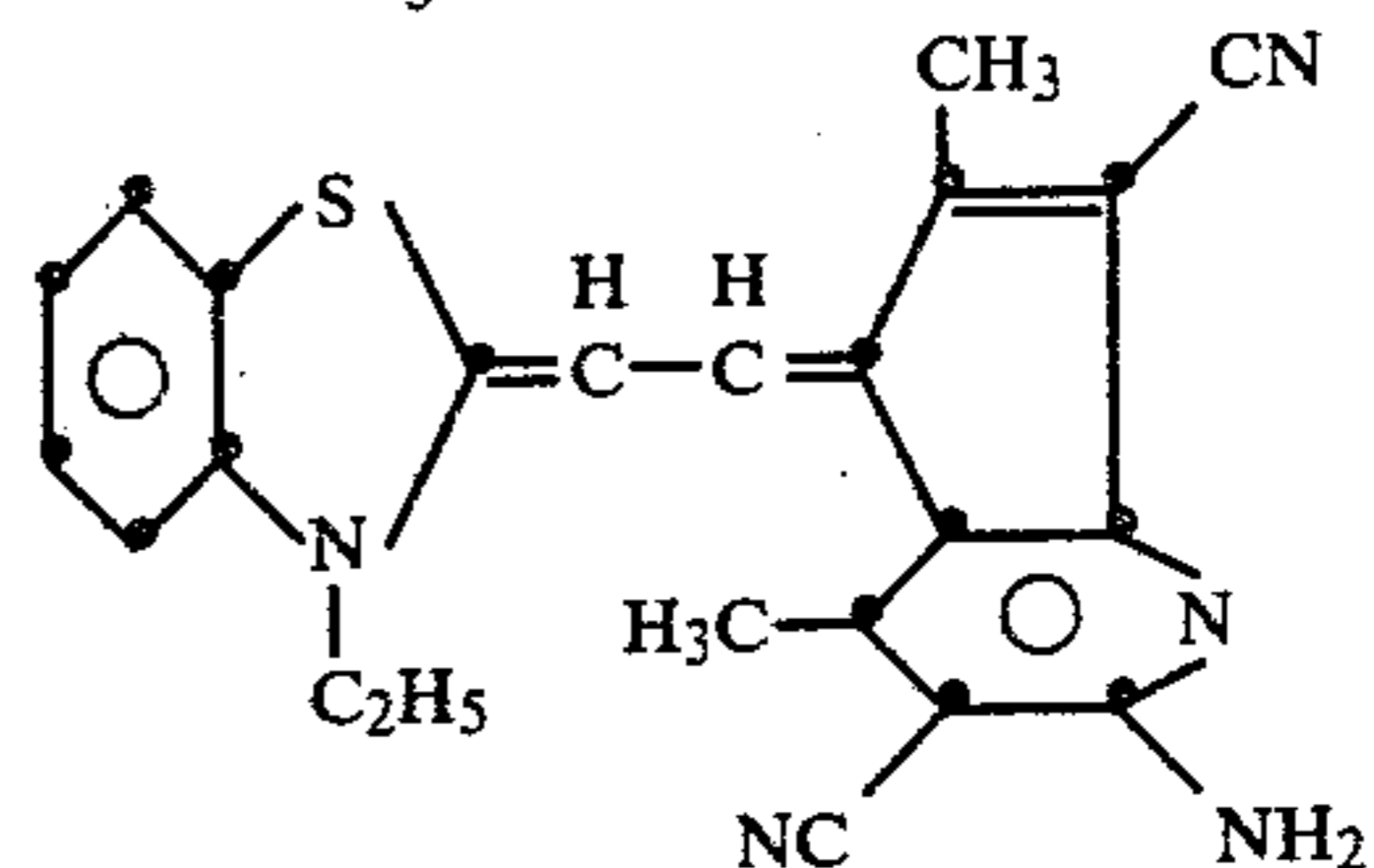
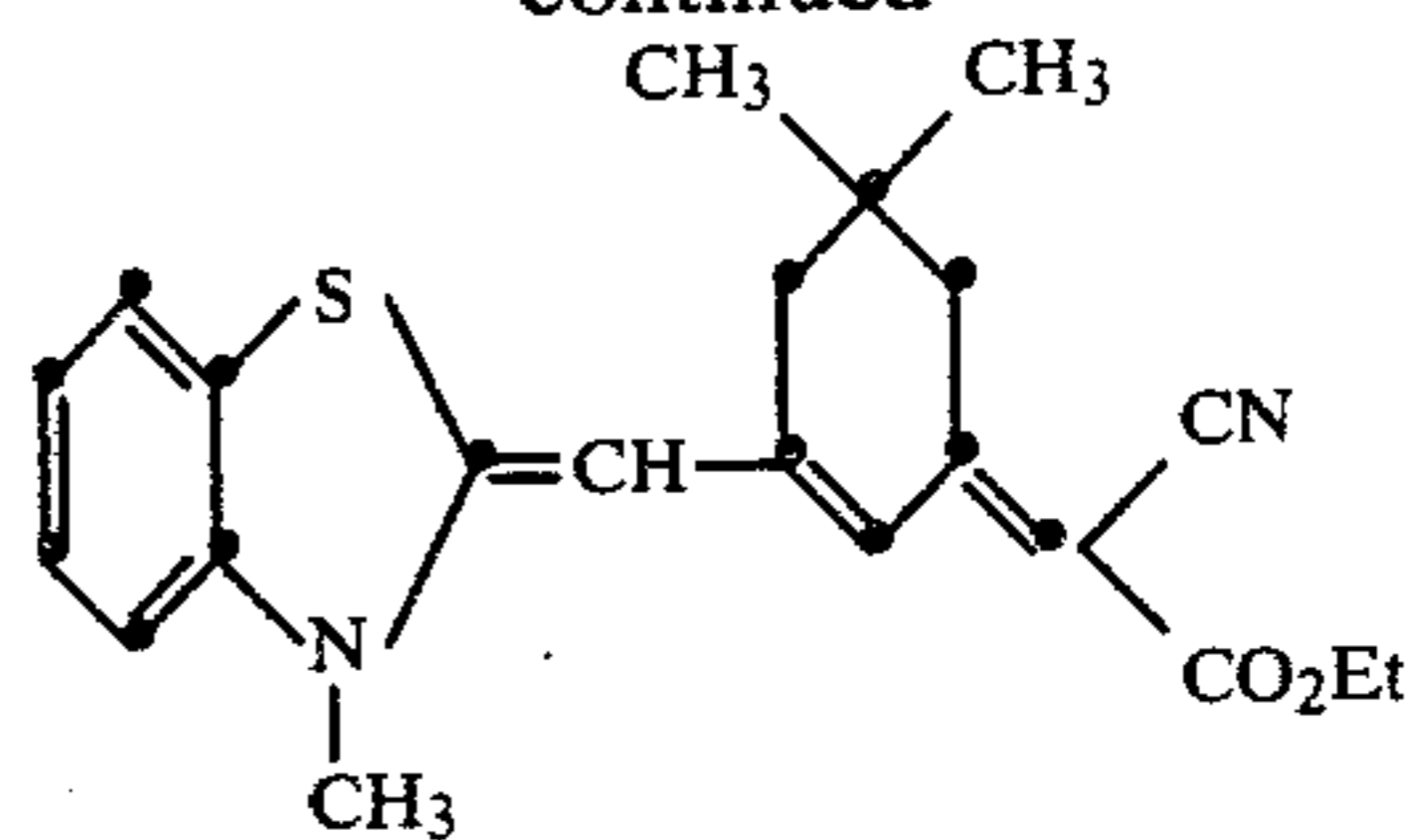

* * * * *

5
10
15
20
25
30
35
40
45
50
55
60
65