

- [54] **FILTER PAPER CUP FOR A PERCOLATOR AND PROCESS FOR MAKING THE SAME**
- [75] Inventors: **Wallace E. Olney; Robert G. Wright,** both of Portage, Mich.
- [73] Assignee: **Brown Company, Kalamazoo, Mich.**
- [21] Appl. No.: **686,111**
- [22] Filed: **May 13, 1976**
- [51] Int. Cl.² **A47J 31/08**
- [52] U.S. Cl. **99/310; 93/86; 210/493 R; 210/505; 210/508; 428/35; 428/153**
- [58] Field of Search **210/493 R, 483, 500 R, 210/503-505, 506-508; 428/35, 153; 162/111, 113; 99/295, 306, 310; 93/86; 264/163, 82; 426/433, 77-84**

3,455,778	7/1969	Bernardin	162/113
3,490,356	1/1970	Peterson et al.	99/295
3,811,373	5/1974	Telco	426/82
3,935,318	1/1976	Milhailide	426/86

Primary Examiner—Frank Sever
Attorney, Agent, or Firm—Gordon W. Hueschen

[57] **ABSTRACT**

A percolator having a cylindrical basket concentric with a wand is provided with a filter paper cup having an annular bottom coextensive with the bottom of the basket and having upstanding fluted sides, characterized in that the flutes are steam and heat set. The filter cups are formed by cutting and forming them into a nest of cups having an imperforate bottom, heating the nested cups, exposing them to moist steam, heating to dry the steamed cups, and cooling them to ambient temperature, transferring the nest of cups to a frusto-conical die having a circular top commensurate with the circular bottom of the filter cups, a central die-hole, and outwardly and downwardly flaring sides corresponding to the natural outward flare of the nested cups, and punching an axial hole in said nested cups while on said die by means of a punch complementary with said die-hole.

- [56] **References Cited**
- U.S. PATENT DOCUMENTS**
- 2,171,484 8/1939 Squire 99/306
- 2,234,397 3/1941 Bentz 99/306
- 2,546,874 3/1971 Siegrist 428/35
- 2,780,573 2/1957 Davidson 162/113
- 3,374,897 3/1968 Martin 99/306
- 3,410,196 11/1968 Potts 99/295
- 3,446,624 5/1969 Luedtke 426/77

6 Claims, 9 Drawing Figures

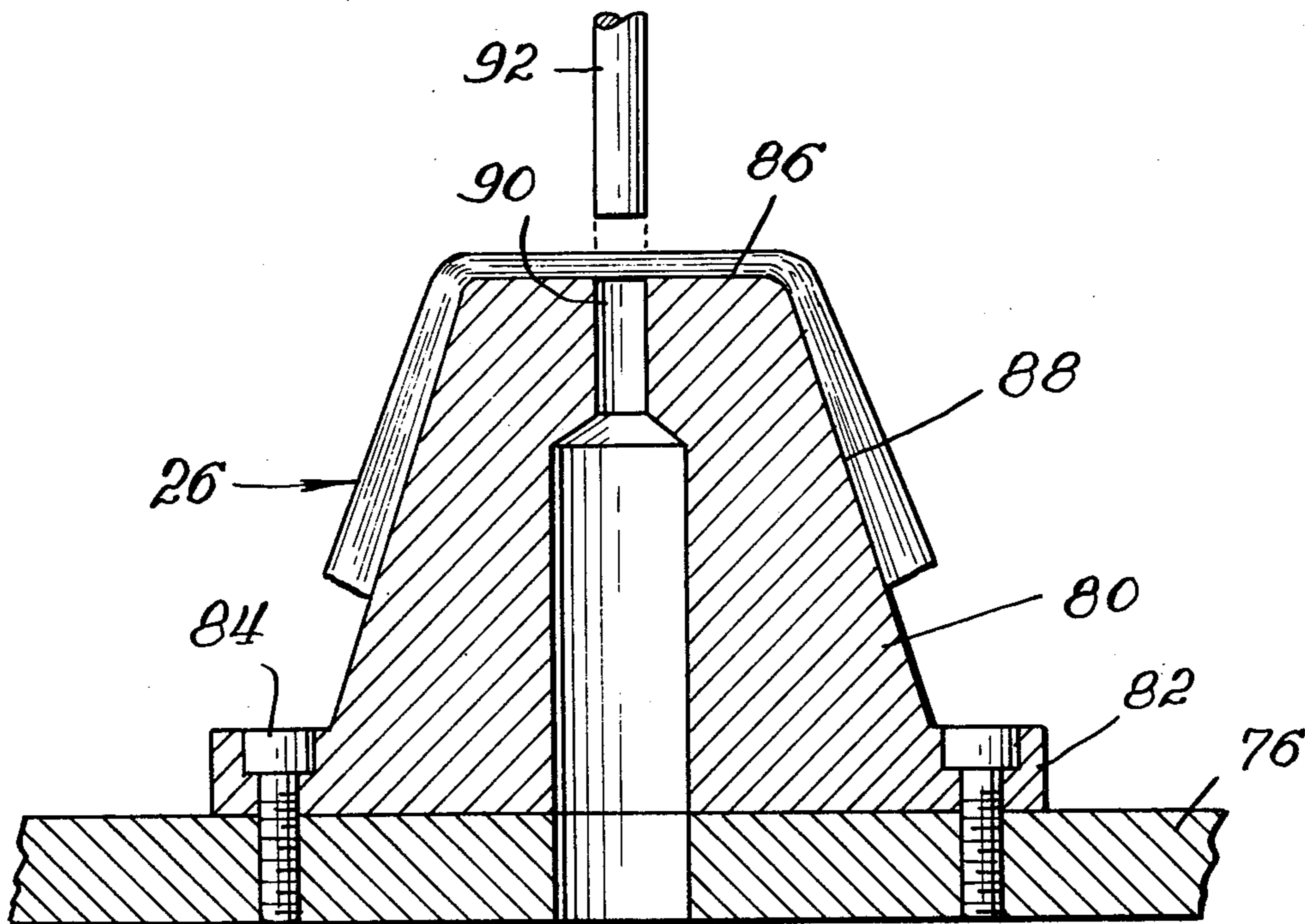

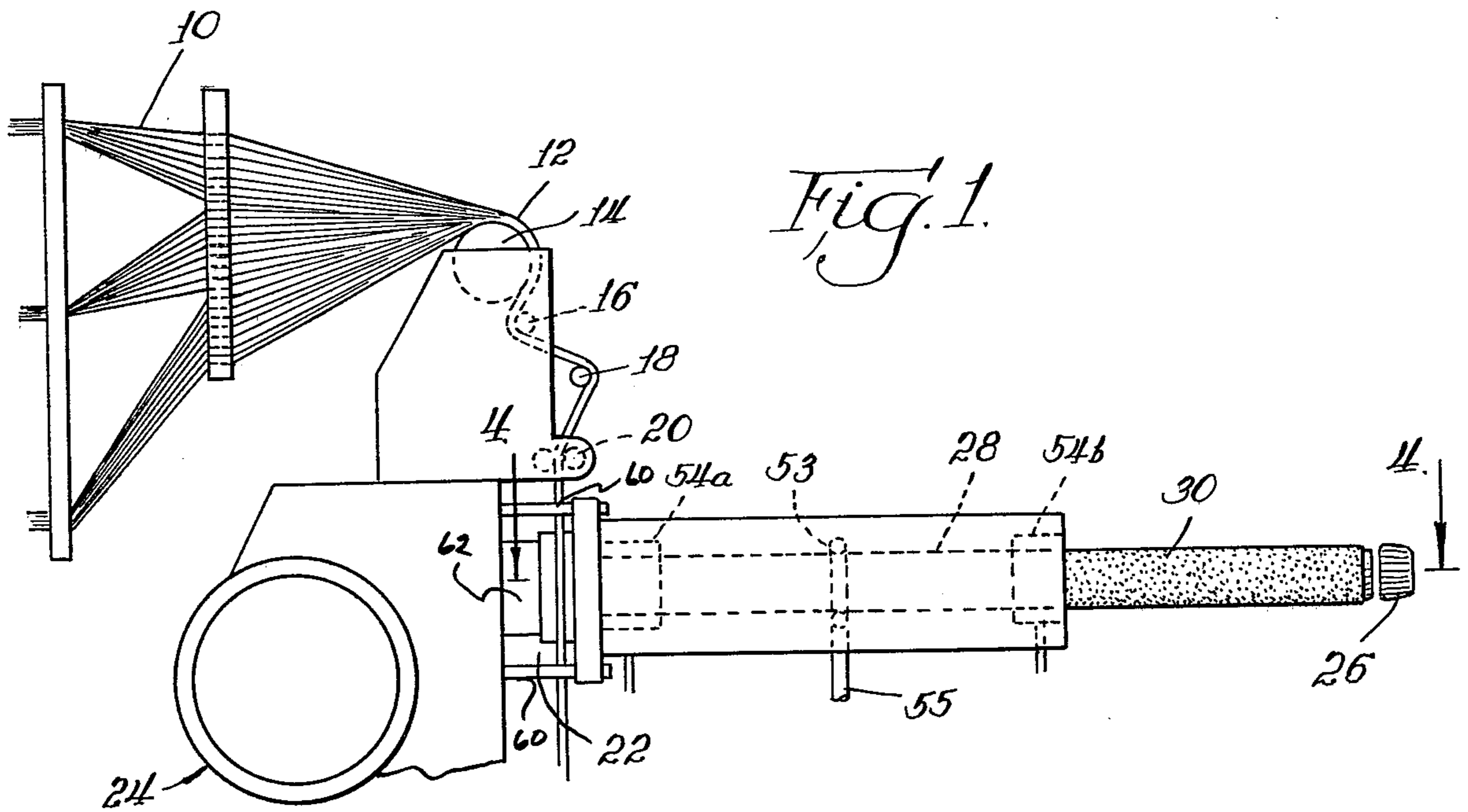

Fig. 1.

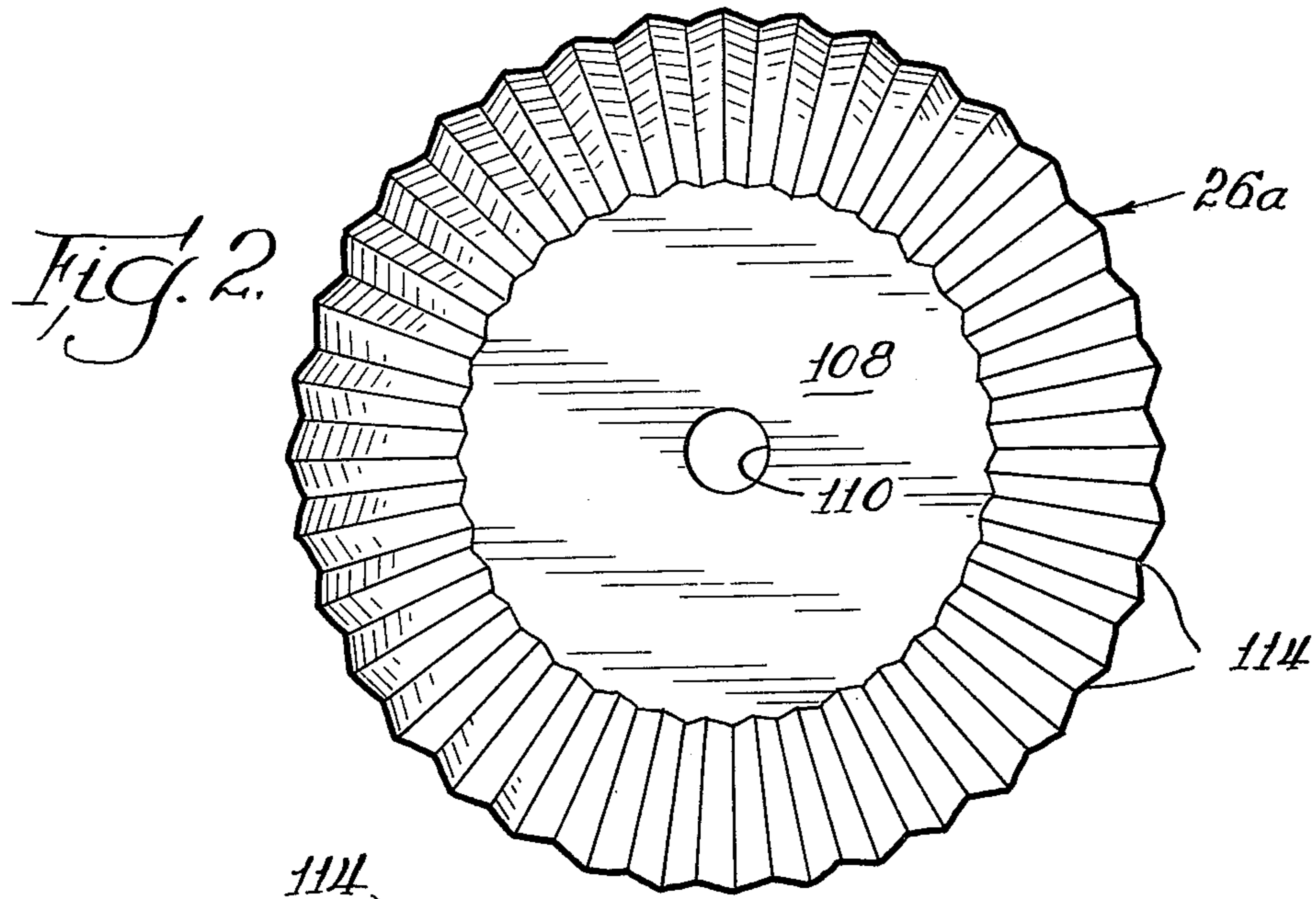

Fig. 2.

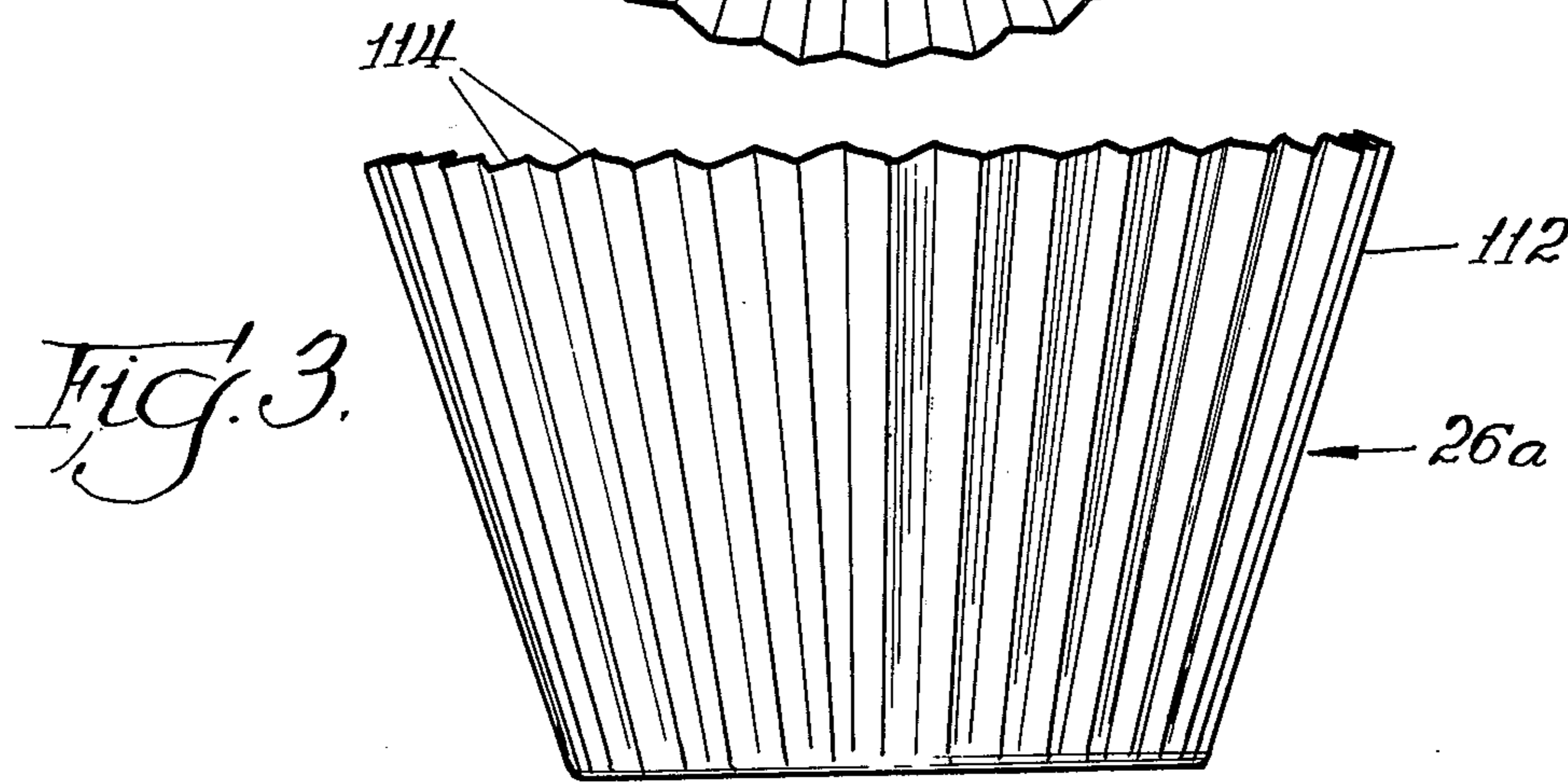

Fig. 3.

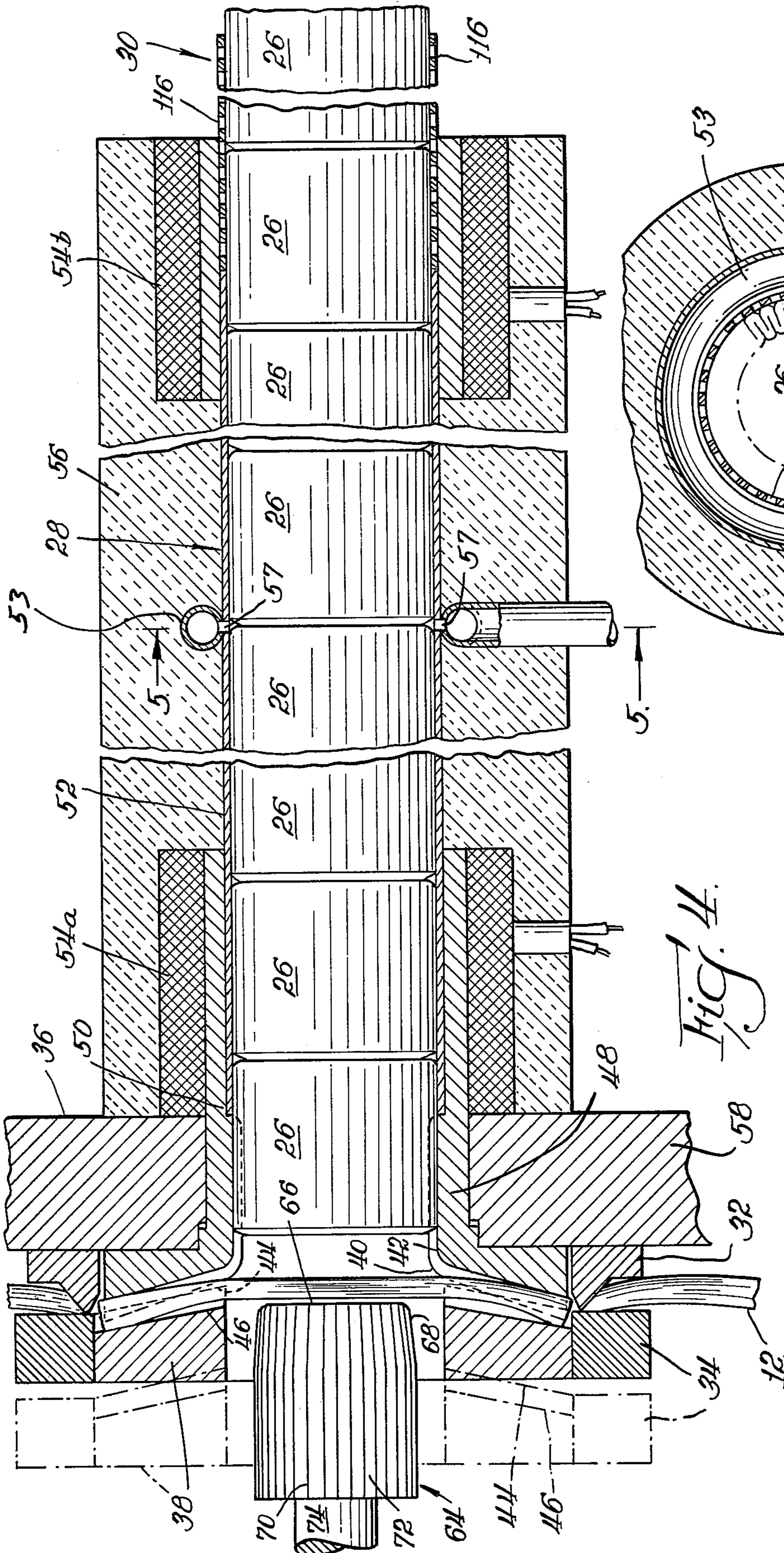

FIG. 4.

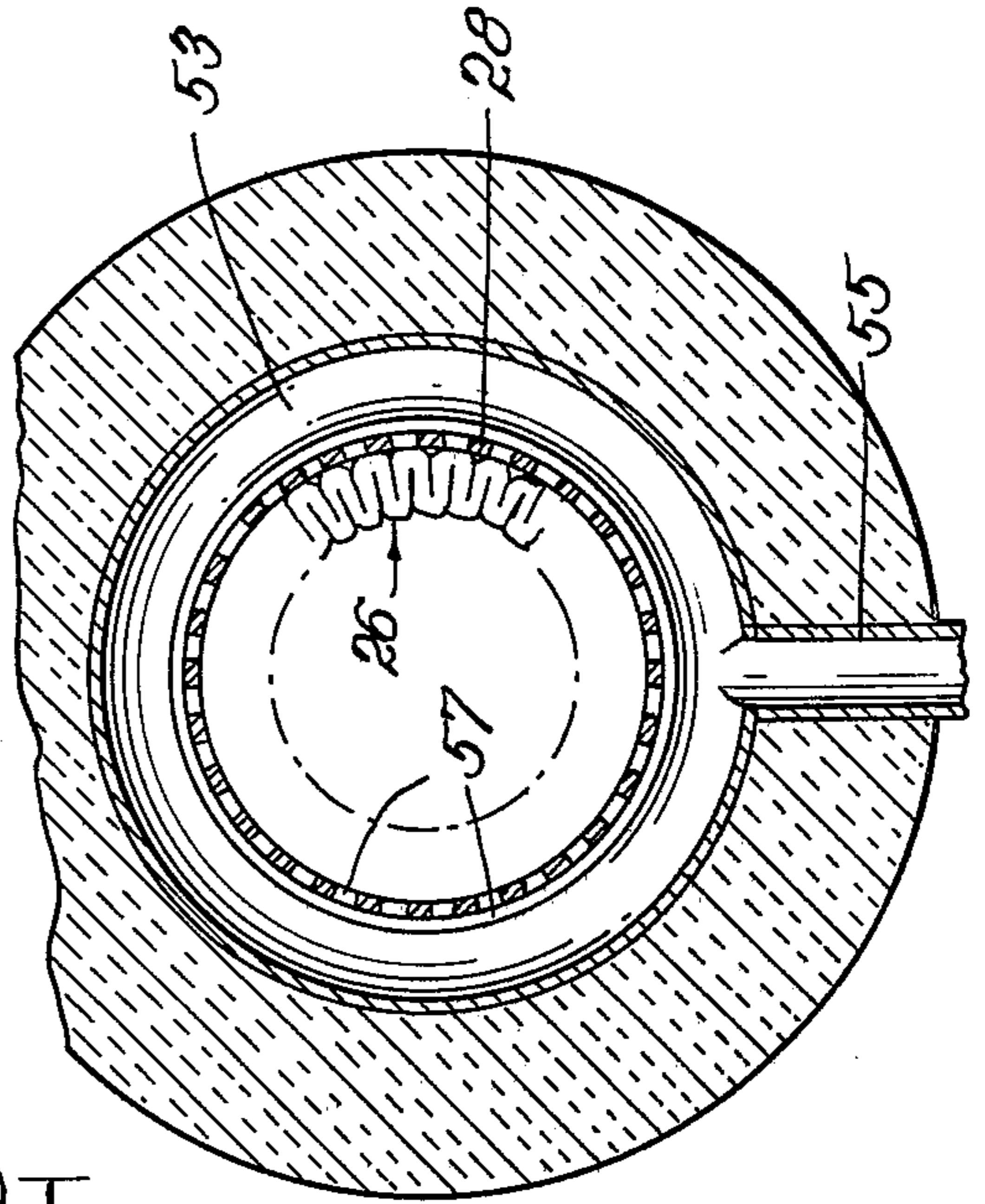

FIG. 5.

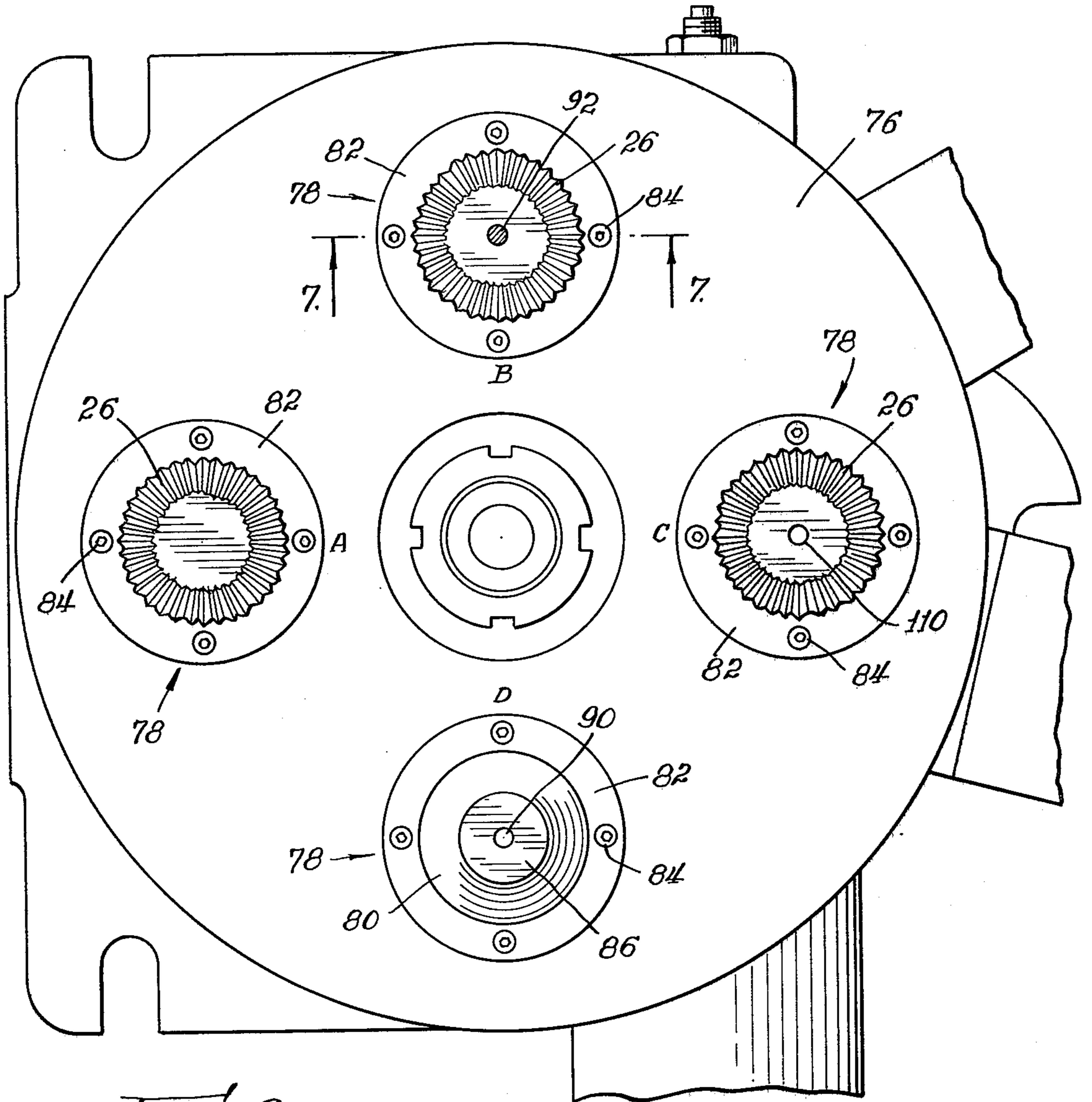

Fig. 6.

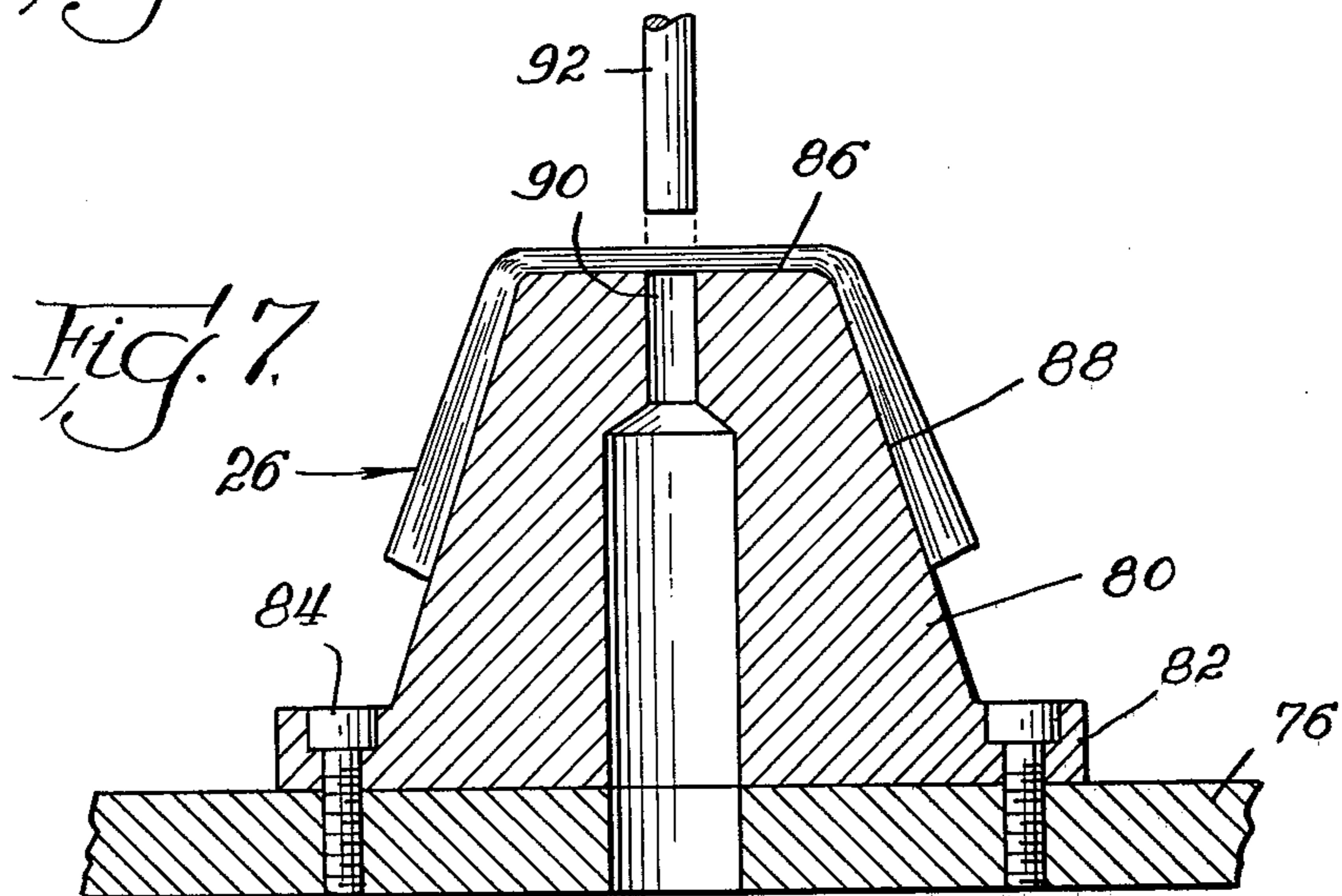
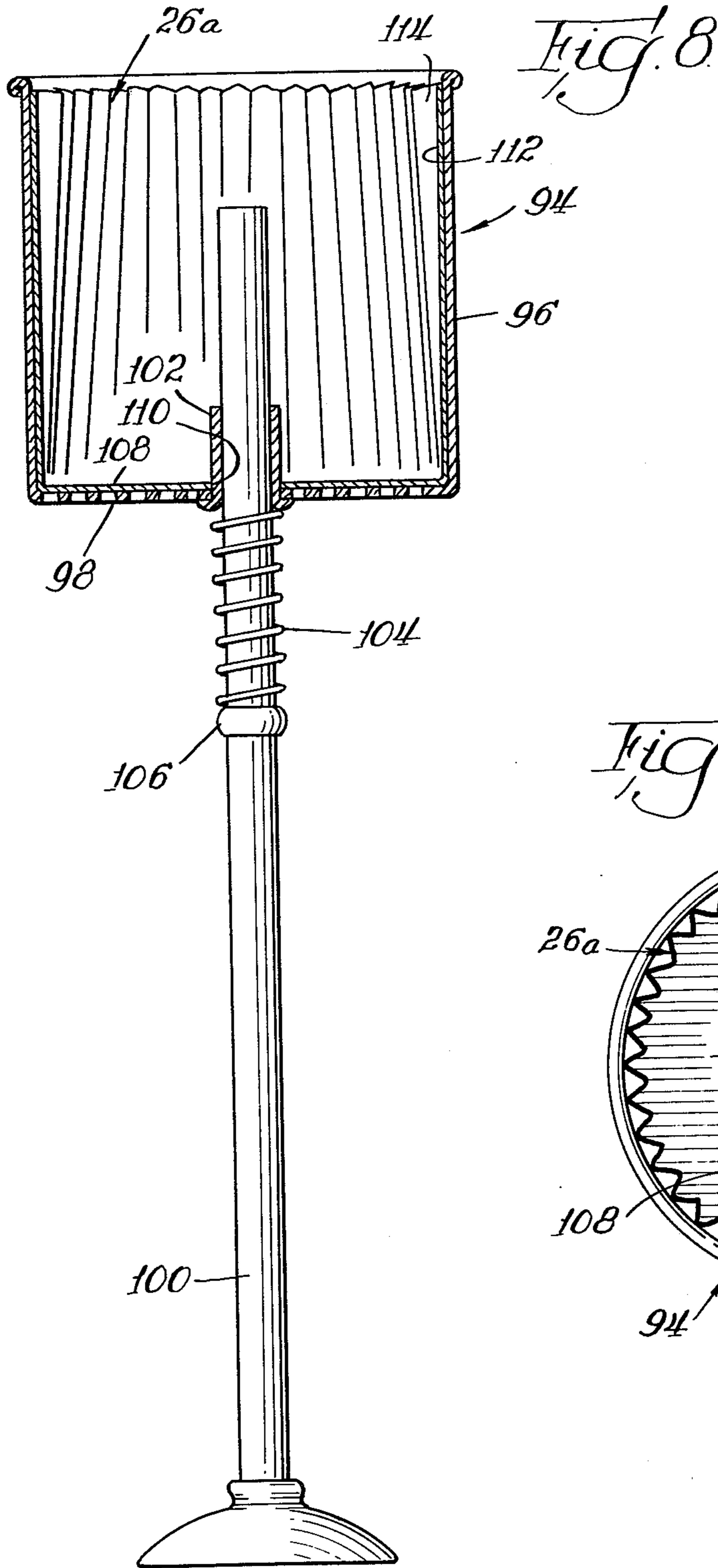

Fig. 7.



FILTER PAPER CUP FOR A PERCOLATOR AND PROCESS FOR MAKING THE SAME

BACKGROUND OF THE INVENTION AND PRIOR ART

The invention relates to apparatus for making coffee and is particularly directed to improvements in percolators for this purpose.

There are types of coffee makers now available in which the coffee is brewed and filtered in an automatic or semi-automatic process. Still, many people believe that brewing coffee is an art rather than a science and prefer apparatus such as percolators where art rather than science goes into the making of the coffee. It has been proposed, heretofore, to use filter cups of sorts in percolators but such as have been available have been expensive, inelegant, and relatively ineffective.

OBJECT OF THE INVENTION

It is an object of the invention to provide a new and improved percolator. It is a further object of the invention to provide percolators having disposable filters which are elegant, inexpensive and efficient. It is a further object of the invention to provide such disposable filter cups suitable for use in percolators. Still a further object of the invention is to provide new and improved process for making such filter cups. It is a further object of the invention to avoid the disadvantages of the prior art and to obtain such advantages as will appear as the description proceeds.

BRIEF DESCRIPTION OF THE INVENTION

This invention relates to a new and improved percolator having a cylindrical basket concentric with a tubular wand and a filter paper cup having an annular bottom coextensive with the bottom of said basket and having integral upstanding, steam and heat-set, fluted sidewalls engaging the sidewall of the basket and projecting upwardly from the periphery of said annular bottom; to a process for making the same in which a set of nested cups having a circular bottom and upstanding fluted sidewalls is first formed, heated, steamed with moist steam, dried, and cooled to ambient temperature, and then placed on a frustro-conical die having a circular top substantially the same diameter as the central portion of the nested cups, a central die-hole and sides flaring outwardly and downwardly complementary with the natural outward flare of the sidewalls of said nested cups, and punching an axial hole in the bottoms of said nested cups by means of a punch complementary to said die-hole; and to the cups so formed.

In carrying out the process of the invention, a plurality of sheets or webs of filter paper are assembled into a composite web and fed into an annular die having a peripheral cutting edge. The male and female portions of the die have radially extending complementary lands and grooves whereby flutes are imparted to the annular portion of the composite disc in said die. The female portion of the die also has a tubular extension having lands and grooves complementary to the lands and grooves in the male die portion. A ram having a diameter essentially the diameter of the cups to be formed then engages the fluted web of filter discs and forces it into said tubular portion, thereby forming a nest of cups. The tubular portion has a tubular extension in which the nested cups are successively heated, steamed with moist steam, dried, and cooled to ambient temperature. Ad-

vantageously, the nested cups are first heated to about 400° to 420° F, then steamed with moist steam, say, of about 90 percent quality, and dried at a temperature of about 400° to 420° F, to a moisture content between about 3 and about 6 percent moisture. With each operation of the die, the nested cups are advanced in the tube a distance equal to the height or length of the nested cups and ultimately, with each operation of the die, a set of nested cups will be ejected from said tube. With each ejection of a set of nested cups, the set is transferred by hand or by suitable machinery to a frustro-conical die having a circular top substantially the same diameter as the central portion of the nested cups, a central die-hole, and sides flaring outwardly and downwardly complementary with the natural outward flare of the sidewalls of the nested cups. A punch complementary with said die then punches an axial hole in the bottom of the set of nested cups.

The filter paper which has been found particularly useful for making the filter cups of the invention consists essentially of pure bleached cellulose fiber from chemically prepared wood pulp fibers. It is uncalendered and unsized, has a 28 to 40 pound basis weight, and a 16 to 15 percent crepe. Other types may be used, however.

The nested cups thus produced have an annular bottom and upstanding having accordian pleat-type flutes therein with rectilinear apices sidewalls and are adapted for insertion into the basket of a percolator. For this purpose it is of advantage to have a large number of flutes, preferably 1 flute at least every 10° and, at most, not more than 1 every 15°.

These cups are particularly adapted for use in percolators in which the basket has an axially disposed, tubular collar which projects upwardly from the bottom of the basket and embraces the wand with a sliding fit so that the basket can be removed from the wand. The annular bottom of the filter cup is coextensive with the annular bottom of the basket and extends from the axial collar to the sidewall of the basket. It will be understood, however, that in the broader aspects of the invention, the cups may be designed for use in a percolator in which the basket and the wand are integral, in which case, the axial aperture in the filter cup will have the same diameter as the wand.

The process of the invention is particularly adapted to producing cups having an accurately centered aperture so that when the cups are placed in the basket of the percolator, the annular bottom of the filter cup will be coextensive with the bottom of the basket and the outermost apices of the flutes of the filter cups will be in uniform engagement with the sidewall of the basket.

DETAILED DESCRIPTION OF THE INVENTION

In The Drawings:

FIG. 1. is a schematic view in side elevation showing how the nested cups are formed.

FIG. 2 is a plan view of a filter cup according to the invention.

FIG. 3 is a side view of the same cup.

FIG. 4 is a detailed view of the cup-forming die and the heating and cooling tube.

FIG. 5 is a section taken along line 5—5 of FIG. 4.

FIG. 6 is a plan view of the punching die assembly.

FIG. 7 is a cross-section taken along line 7—7 of FIG. 6.

FIG. 8 is a side elevation in section of a percolator basket and wand having a filter cup therein.

FIG. 9 is a cross-section of the basket of FIG. 8.

Referring now, particularly to FIG. 1, a plurality of single sheets or webs 10 of filter paper are assembled as illustrated into a composite web 12, which is fed by suitable rollers means 14, 16, 18, and 20 into the forming die 22 operated by ram press 24, where the composite web 12 is cut and shaped into nested cups 26, which pass through the setting tube 28 and cooling tube 30.

The roller 18 is constructed and arranged to take up the slack in the composite web during the forming operation, in which case the roller 14 operates continuously. Alternatively, the roller 12 may be operated intermittently to feed the composite web to the forming die 22 as needed.

The forming die 22 is provided with an annular cutting ring 32 operating on the annular anvil 34 and is provided with a female portion 36 and a male portion 38, which latter is operated to and from the position shown in dotted lines by the ram press 24. The female portion 36 of the die 22 is provided with alternating lands 40 and grooves 42 and the male portion is provided with complementary lands and grooves 44 and 46 adapted to form flutes in the annular portion of the cut filter discs which are clamped between the annular portions of the female and male die portions 36 and 38.

The female portion 36 of the forming die 22 has a tubular extension 48 and the lands and grooves 40 and 42 extend into this tubular extension as shown by the dotted lines up to the shoulder 50, where the tubular extension 48 is enlarged to receive the heating and cooling tube 52 which is composed of heating section 28 and cooling section 30.

The setting section 28 is provided with at least two heating elements 54a and 54b spaced about its length, advantageously, one near the beginning and one near the end as shown in FIG. 4, and the whole is lagged with insulating material 56 which may be asbestos, polyurethane foam, or any other suitable insulating material. Intermediate between the two heating elements 54a and 54b is an annular manifold 53 having a steam inlet pipe 55 and apertures 57 connecting the manifold with the interior of the setting tube 28, so that moist steam can be introduced into the setting tube to moisten the hot nested cups therein.

The female die 36 with its tubular projection 48 is sweated into or otherwise fastened to a collar 58 which is fastened to the ram press 24 by the tie rods 60. The male die member is affixed to the ram 62 of the ram press 24.

The ram 62 is hollow, having a diameter roughly corresponding to that of the forming die. Disposed axially in the hollow ram is a pusher 64, the front end 66 of which has a diameter roughly corresponding to the inside diameter of the nested cups. Advantageously, the pusher 64 may slope outwardly as shown at 68 at an angle of between about 1° and about 5° and, if desired, may be fluted to provide alternating lands 70 and grooves 72 corresponding, respectively, to the grooves 42 and lands 40 of the female die 36 and its tubular extension 48. The pusher 64 is affixed to the end of rod 74 which can be actuated by means, not shown, in the ram press 24 to push the composite web out of the die after it has been cut and formed therein and into the tubular extension 48. After repeated operation as above described, the heating and cooling tube 52 will be filled with a plurality of columnarized nested cups 26. Finally,

after the requisite number of operations, one set of nested cups 26 will be ejected from the heating and cooling tube 52 as shown in FIG. 1.

The set of nested cups thus ejected is then transferred either by hand or by mechanical means to a die where a center hole is punched in the bottom of the cup.

FIG. 6 shows in fragmentary form a suitable die machine for this purpose, including a turntable 76 adapted to be rotated by indexing means, not shown, from loading station A to punching station B to discharge or unloading station C. A fourth station, D, is shown which may be utilized for unloading or for loading as desired, or maybe omitted entirely.

Each station is provided with a punch die 78. Each punching die 78 is provided with a base 80 having an annular flange 82 at the bottom thereof. The base 80 is secured to the turntable 76 by means of fasteners 84 in the flanges 82.

The base of the die 80 is shaped like a truncated cone, the top surface of which has essentially the same diameter as the bottom of the filter cups and the sides of which slope outwardly and downwardly as shown at 88 substantially at the angle of flare of the nested cups after they are discharged from the cooling tube. Ordinarily it will be sufficient if the sides slope outwardly and downwardly at an angle of about 10° to about 30°.

The top of the die base 80 has an axial die-hole 90, axially aligned with punch 92. When the nested cups 26 are placed on the die base 80 as shown in FIG. 7, the cups are automatically centered so that the punch 92 will punch a hole in the bottom of the nested cups which is at the exact center of the several cups in the nest. If desired, a clamp, not shown, may be arranged to press the nested cups firmly in contact with the top 86 of the die base 80 before the punching operation.

The individual cups are proportioned to conform with the basket 94 of a standard percolator, not shown. The basket in the form shown in FIG. 8 has an upstanding sidewall 96 and a bottom 98. The bottom is perforated and, if desired, part or all of the sidewall 96 may be perforated. Extending axially upwardly through the basket 94 is a wand 100. In the form shown, the basket 94 has an axial collar 102 projecting upwardly from the bottom 98 of the basket. The wand 100 has a slidable fit with the collar 102 so that the basket can be removed from the wand and replaced as desired. In some forms of percolators with the outermost apices of the flutes being substantially entirely in contiguous relationship with the inner wall of the basket of the percolator, the basket rests on spring 104 which is affixed to the wand 100 at some lower point 106. In other forms, not shown, the collar 102 is omitted and the bottom 98 of the basket is attached to the wand.

The filter cup 26a produced by the process of the invention is shown in FIGS. 2 and 3. It has an annular bottom 108 with an axial opening 110 of the same diameter as the collar 102, and upstanding sidewalls 112. The upstanding sidewalls 112 are provided with a plurality of flutes 114 about the periphery thereof which function, as shown in FIGS. 8 and 9, like accordion pleats when the filter cup is placed in the basket of the percolator, thus acting to take up the surplus paper and allowing the cup to assume roughly the cylindrical shape of the basket of the percolator.

In order for the filter cup to effectively assume the cylindrical shape of the basket of the percolator, it is advantageous that the center hole be accurately centered and the flutes be relatively small. Preferably, there

should be at least 1 flute for every 10° of the periphery of the annular base of the filter cup and, advantageously, 1 flute for at least every 15°. Advantageously, also, the filter paper is composed essentially of bleached cellulose fiber from chemically prepared wood pulp which is uncalendered and unsized, is creped about 6 to about 15 percent, has a moisture content between about 3 and about 6 percent, and has about 28 to about 40 pound basis weight. When the filter cups are so constructed and the flutes are heat and steam-set by adequate heating, steaming, and drying in the setting tube, and adequate cooling in the cooling tube, a filter cup is provided which is inexpensive to make, elegant in appearance, and efficient for its intended purpose. It also provides a filter cup which retains its shape with an outward flare of about 25° to about 30°.

The cooling tube 30, advantageously, is perforated as shown at 116 and, if desired, the perforations may extend up into the portion of the setting tube 28 which is covered by the heating element 54b.

The female member 36 of the forming die 22 is dish-shaped or concave, whereas the male portion 38 is convex. This facilitates the pulling out of the annular fluted portions from the die when the pusher 64 engages the central portion of the cut and formed composite web to push it into the tubular extension 48. Thus, the annular portion of the female member 36 slopes upwardly as shown in FIG. 4 and the annular portion of the male member 38 has a complementary slope. The angle of slope ordinarily is around 10° to 15°, but, if desired, may range from an angle of about 10° to about 30°.

The length of the setting tube 28 and the length of the cooling tube 30 is not critical and may be varied over a wide range consistent with the purpose of obtaining a good set of the flutes in the filter cup.

It is to be understood that the invention is not to be limited to the exact details of operation or structure shown and described as obvious modifications and equivalents will be apparent to one skilled in the art.

We claim:

1. In a percolator for brewing coffee comprising a cylindrical basket concentric with a tubular wand, the combination therewith of a filter paper cup having a flat annular bottom coextensive with and lying flat on the bottom of said basket and having an integral upstanding steam and heat-set sidewall only at the outer periphery of said annular bottom, said upstanding sidewall being fluted with accordian pleat-type flutes and said flutes being under compression by the fact that said upstanding sidewall normally flares outwardly when unconfined by said basket, but is constrained to a vertical position by said basket, in which the filter paper is composed essentially of bleached cellulose fiber from chem-

ically processed wood pulp, is uncalendered, is unsized, is creped from about 6 to about 15 percent, and has a basis weight between about 28 and about 40 pounds, in which the sidewalls of the filter cup have at least 1 flute every 15°, and in which said flutes are steam and heat set by heating the cups to a temperature of about 400° to 420° F to a moisture content between about 3 and about 6 percent while the sidewall is constrained in a cylindrical position, and substantially only the outermost apices of said flutes are substantially entirely in contiguous relationship with the inner wall of said basket into which said paper filter cup is placed.

2. The percolator of claim 1, in which the sidewalls of the filter cup have at least 1 flute every 10°.

3. The percolator of claim 1, in which the basket has an axially disposed, tubular collar which projects upwardly from the bottom of said basket and embraces said wand with a sliding fit whereby the basket can be removed from said wand and in which the annular bottom of said filter cup extends from said upstanding sidewall to and terminates in contact with said collar.

4. The percolator of claim 3, in which the sidewalls of the filter cup have at least one flute every 10°.

5. A filter paper cup adapted for use in a percolator having a cylindrical basket concentric with a tubular wand comprising an annular bottom having an integral upstanding steam and heat-set wall only at the outer periphery of said annular bottom, said upstanding wall flaring outwardly and being fluted with accordian pleat-type flutes, and in which the filter paper is composed essentially of bleached cellulose fiber from chemically processed wood pulp, is uncalendered, is unsized, is creped from about 6 to about 15 percent, and has a basis weight between about 28 and about 40 pounds, in which there is at least one flute for every 15°, and in which said flutes are steam and heat set by heating the cup to a temperature of about 400° to 420° F, steaming with moist steam of about 90 percent quality, and then dried at a temperature of about 400° to 420° F to a moisture content between about 3 and about 6 percent while the sidewall is constrained in a cylindrical position, the outermost apices of said flutes being rectilinear so that, when the filter cup is inserted into the cylindrical basket of said percolator with the annular bottom of said filter cup being coextensive with and resting on the bottom of said basket and extending from said tubular wand to the outer wall of said cylindrical basket, substantially only the outermost apices of said flutes will be in substantially entirely contiguous relationship with said inner wall.

6. The filter paper cup of claim 5, in which there is at least one flute for every 10°.

* * * * *

55

60

65

UNITED STATES PATENT AND TRADEMARK OFFICE
CERTIFICATE OF CORRECTION

PATENT NO. : 4,094,234

DATED : June 13, 1978

INVENTOR(S) : Wallace E. Olney & Robert G. Wright

It is certified that error appears in the above-identified patent and that said Letters Patent are hereby corrected as shown below:

ABSTRACT, line 10; "frusto" should read --frustro--
Col. 3, line 7; "rollers" should read --roller--
Col. 3, line 36; "is" should read --its--
Col. 4, line 11; "unloadind" should read --unloading--
Col. 4, line 13; "maybe" should read --may be--
Col. 6, line 25; "cylindrical" should read --cylindrical--

On the title page insert:

--[*] Notice: The portion of the term of this patent subsequent to July 4, 1995 has been disclaimed.

Signed and Sealed this

Fourteenth Day of November 1978

[SEAL]

Attest:

RUTH C. MASON
Attesting Officer

DONALD W. BANNER
Commissioner of Patents and Trademarks