

[54] MAGNETIC LEVITATION GUIDANCE SYSTEM

[75] Inventor: David L. Atherton, Kingston, Ontario, Canada

[73] Assignee: Canadian Patents and Development Limited, Ottawa, Ontario, Canada

[22] Filed: Mar. 26, 1973

[21] Appl. No.: 344,933

[52] U.S. Cl. .... 104/148 SS, 104/148 MS

[51] Int. Cl. .... B61b 13/08

[58] Field of Search.. 104/148 MS, 148 SS, 148 LM

[56] References Cited

UNITED STATES PATENTS

3,470,828	10/1969	Powell, Jr. et al.....	104/148 SS
3,589,300	6/1971	Wipf.....	104/148 SS
3,644,762	2/1972	Eastham .....	104/148 LM
3,662,689	5/1972	Kawabe et al.....	104/148 SS
3,736,880	6/1973	Ross.....	104/148 MS

Primary Examiner—M. Henson Wood, Jr.  
Assistant Examiner—Reinhard J. Eisenzopf  
Attorney, Agent, or Firm—J. R. Hughes

[57] ABSTRACT

A magnetic levitation guidance system having a predetermined arrangement and positioning of the magnets or current carrying conductors in the levitated vehicle in relation to the fixed guideway conductors. In one version of the invention the parallel, longitudinal vehicle magnets or current carrying conductors are positioned such that when the vehicle is positioned above a continuous conducting strip guideway positioned on the trackbed, these magnet edges or current carrying conductors are positioned outward in the horizontal sense of the edges of the conducting strip. In another version where the guideway is the form of loops or ladder shaped arrangements, the parallel, longitudinal portions of the magnet edges or current loops on the vehicle are positioned when the vehicle is centered over the guideways such that these magnet edges or current carrying conductors are placed outwardly or inwardly of the co-acting conductors in the guideway. It has been found that if the magnet edges or current carrying conductors are positioned in this manner, there will be an inherent lateral restoring force that will tend to center the vehicle in relation to the guideway.

2 Claims, 5 Drawing Figures

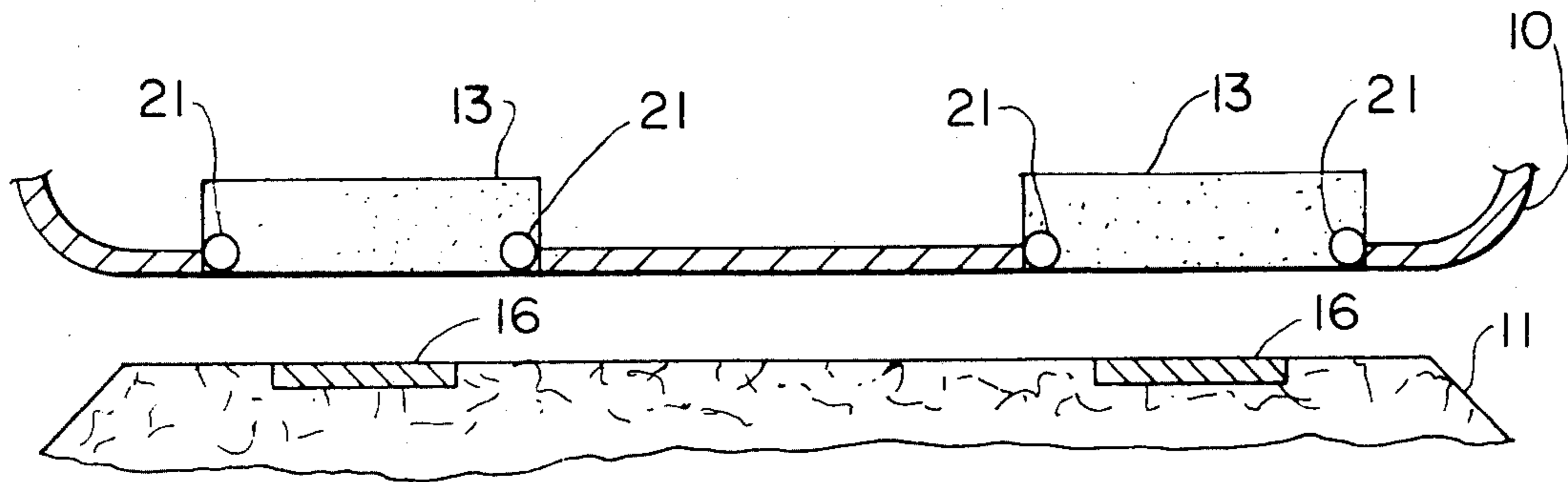

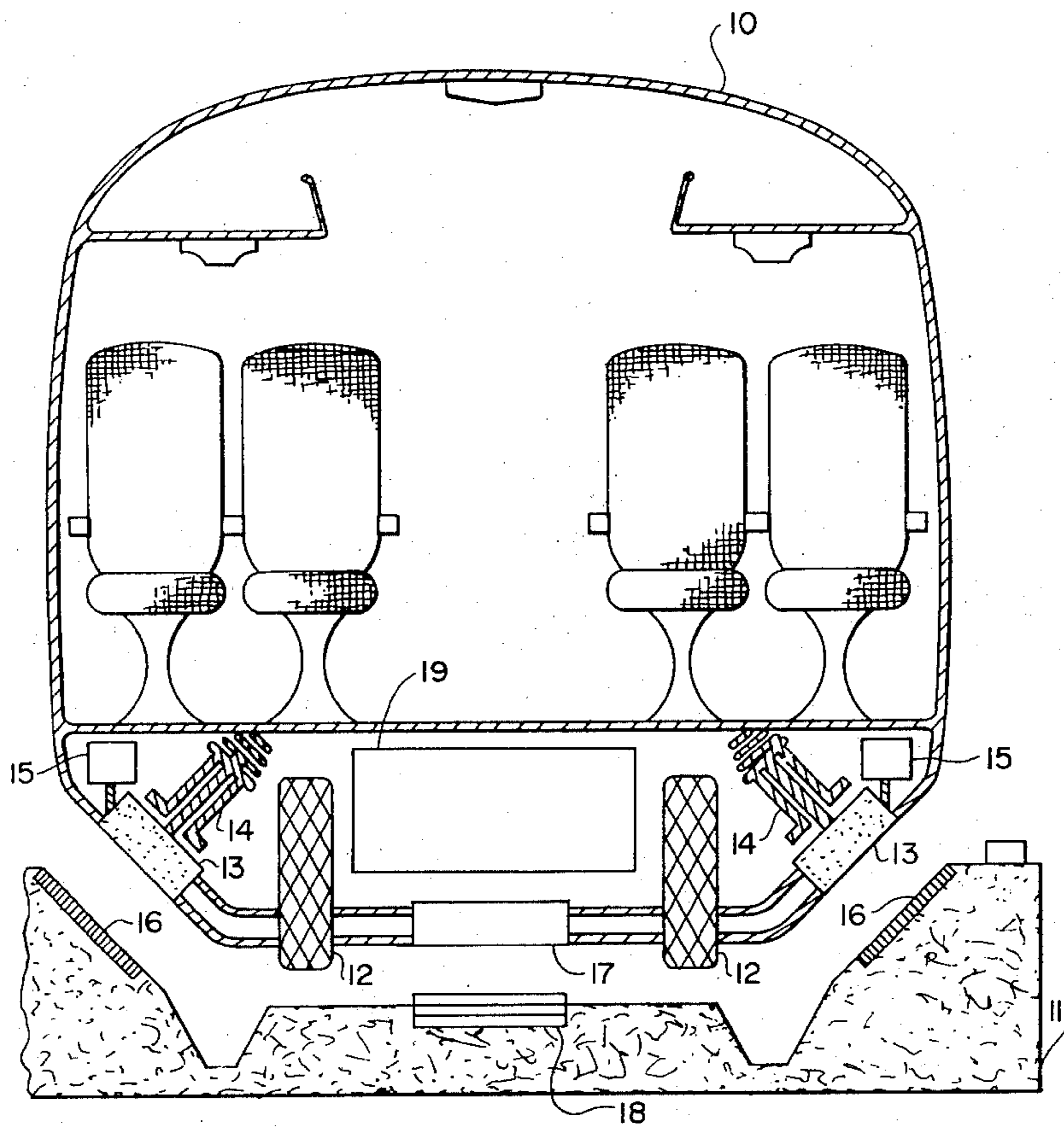

FIG. 1  
PRIOR ART

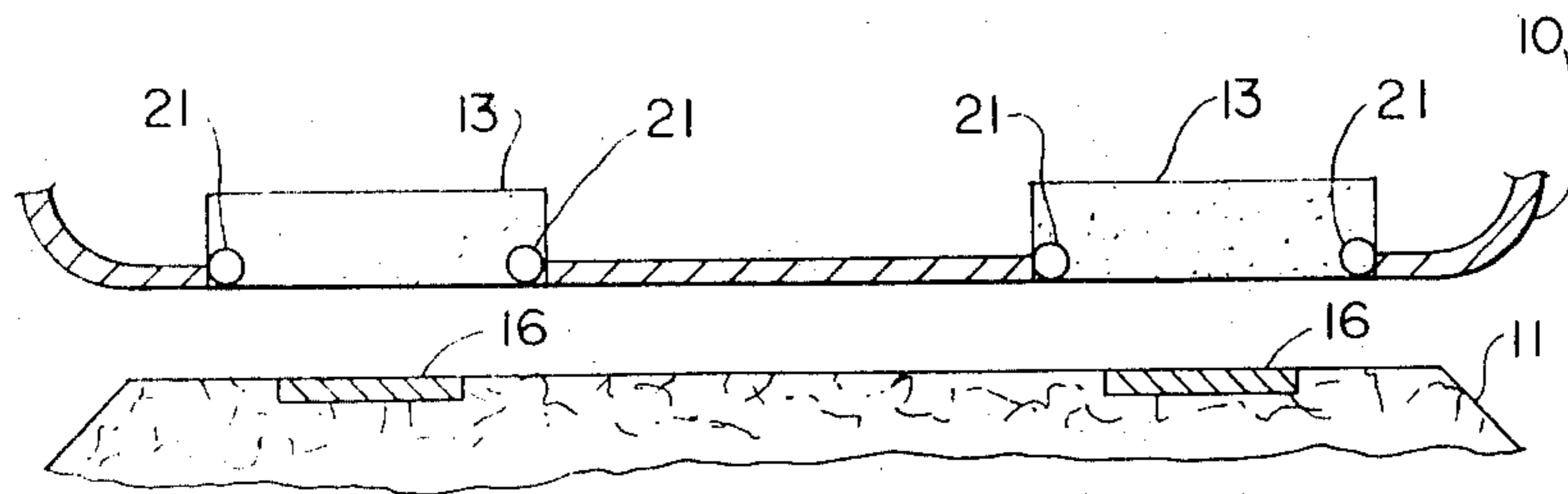

FIG. 2

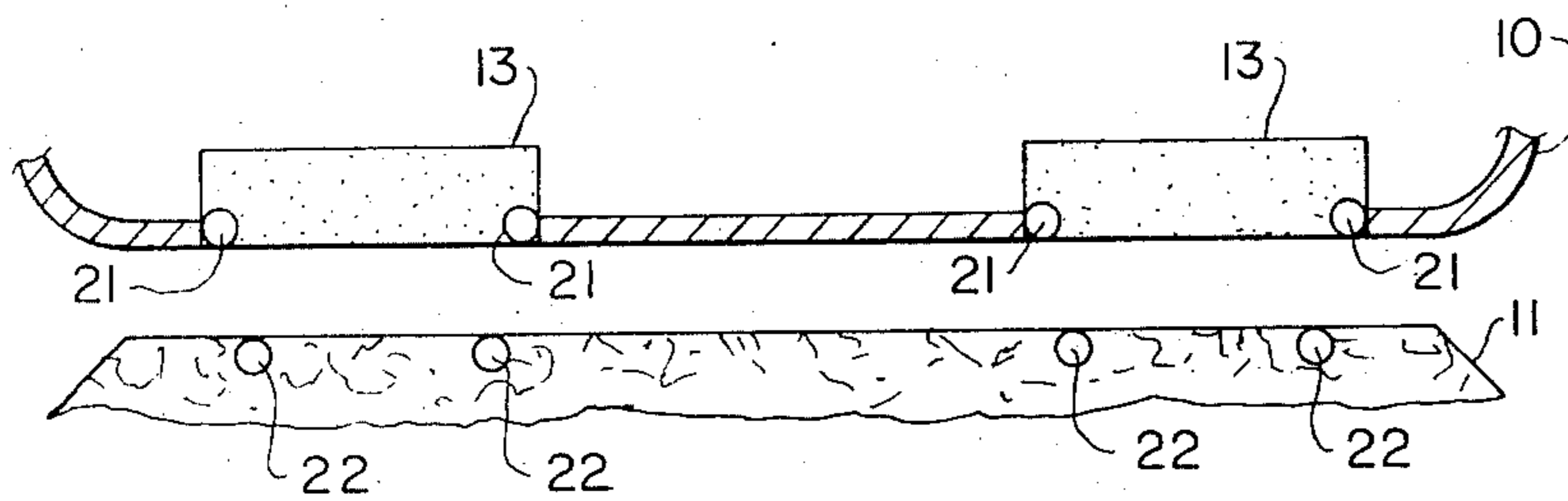

FIG. 3

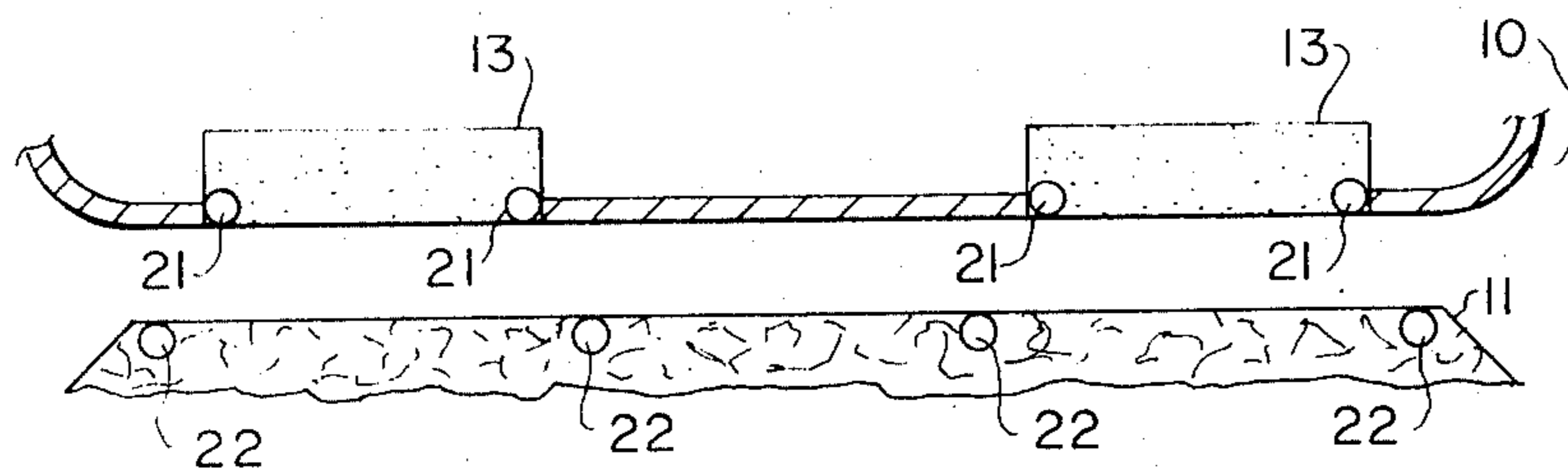

FIG. 4

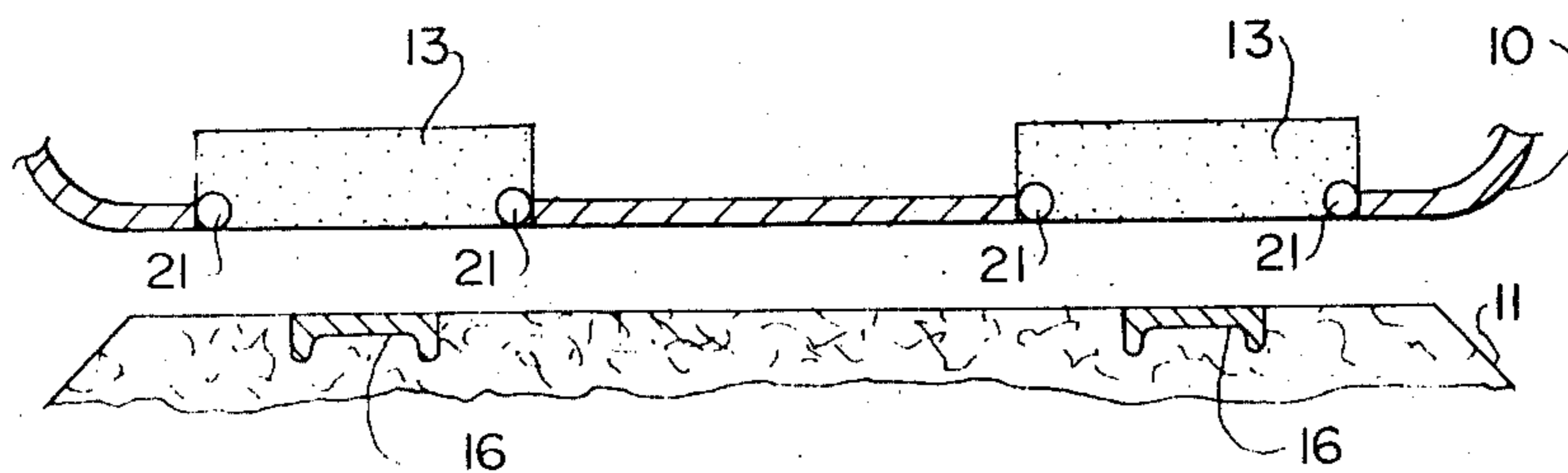

FIG. 5

## MAGNETIC LEVITATION GUIDANCE SYSTEM

This invention relates to a magnetic levitation guidance system and more particularly to an arrangement and positioning of the high strength magnets or the high current carrying conductors in the levitated vehicle in relation to the fixed track or guideway such that inherent lateral guidance forces are obtained.

Magnetic levitation (Maglev) systems are based on the phenomenon known as induction. Basically, eddy currents are induced in an electrically conducting material (on the guideway) when subjected to a time varying magnetic field (set up by a D.C. source carried by the vehicle). These induced currents set up fields that oppose the moving magnetic fields thus generating a lift force on the vehicle. The dissipation in the guideway appears as a magnetic drag force which fortunately peaks at low speed and then decreases as the vehicle speed increases. The principle of this mode of suspension is well known and was demonstrated quite early however only with the recent development of high current density superconducting magnets has the suspension system become economically viable. Superconducting magnets provide a light weight source of high magnetic field with nearly zero power consumption (apart from that required to maintain the magnet at liquid helium temperatures) and those required for magnetic levitation are now well within the current state of technology. The vehicle, which would require wheels for low speeds, may be propelled by any suitable driving system preferably a non contact system such as a propeller, jet engine, or a linear induction motor or ideally a linear synchronous motor.

Two distinct electrodynamic suspension loop and conducting sheet systems. These differ primarily in the configuration of guideway conductor required for levitation. The guideway conductor for the former consists of an arrangement of closed circuit conducting (aluminum for example) rear loops which the vehicle-borne superconducting magnets move. The induced currents are generated by mutual induction between the train magnets and the guideway loops. The guideway conductor for the conducting sheet suspension consists of continuous sheets of aluminum along the track. U.S. Pat. No. 3,470,828 issued to J. R. Powell and G. T. Darby on Oct. 7, 1969 describes the use of levitation loops in the guideway. Others have modified this to a ladder type of guideway. In both systems the vehicle magnets and guideway loops have the same width.

Although the levitation systems described above appear to provide good solutions to the vehicle levitation problems, they give no answer to the problem of lateral stability, that is accommodation for lateral forces represented chiefly by centrifugal and wind forces. It is realized that these latter will be appreciable and therefore definite provision for them must be made. In the Powell et al. patent mentioned above, it is proposed that horizontal, lateral stability of the vehicle be obtained by provision of additional loop arrays for this purpose. This of course adds cost and complexity to the system but also results in a guideway structure that would be hard to maintain and keep clear of snow and dirt that would hinder operation. Another arrangement for providing lateral stability is to arrange the magnet and guideway systems on each side of the vehicle at an angle to the horizontal such that not only vertical levitation forces are obtained but also lateral force vectors.

This works in principle but can result in an unstabilised rolling and lateral motion that is difficult to take care of.

It is an object of the present invention to provide a lateral guidance system for magnetic levitation vehicles that is relatively inexpensive and simple to build and maintain.

It is another object of the invention to provide a lateral guidance system that gives inherent lateral restoring forces that does not need orthogonal (magnetic flange) or non-horizontal (vector) arrangements of magnets and guideway.

These and other objects of the invention are achieved by a predetermined arrangement and positioning of the magnets or current carrying conductors in the levitated vehicle in relation to the fixed guideway conductors. In one version of the invention the parallel, longitudinal vehicle magnets or current conductors are positioned such that when the vehicle is positioned above a continuous conducting strip guideway positioned on the trackbed, these magnet edges or current carrying conductors are positioned outward in the horizontal sense of the edges of the conducting strip. In another version where the guideway is the form of loops or ladder shaped arrangements, the parallel, longitudinal portions of the magnet edges or current loops on the vehicle are positioned when the vehicle is centered over the guideways such that these magnet edges or current carrying conductors are placed outwardly or inwardly of the contacting conductors in the guideway. It has been found that if the magnet edges or current carrying conductors are positioned in this manner, there will be an inherent lateral restoring force that will tend to center the vehicle in relation to the guideway.

In drawings which illustrate embodiments of the invention,

FIG. 1 is a cross-sectional view of a magnetically levitated vehicle in relation to a guideway and propulsion structure,

FIG. 2 is a schematic view of magnet and continuous trip conductor guideway where the current carrying conductors are positioned outwardly of the guideway strips,

FIG. 3 is a schematic view of magnet and loop or ladder guideway conductors where the cryogenic conductors are positioned outwardly of the longitudinal conductors of the guideway,

FIG. 4 is similar to FIG. 3 but shows an arrangement where the cryogenic conductors are positioned inwardly of the longitudinal conductors of the guideway, and

FIG. 5 is an arrangement similar to that of FIG. 2 but where the guideway strips are specially shaped.

Referring to FIG. 1, a prior art magnetic levitation system is shown made up of a vehicle 10 and a guideway structure 11. The vehicle incorporates standard wheels 12 required for start up and low speed running until sufficient speeds providing levitation forces are reached. Superconducting levitation magnets 13 are mounted on suitable suspension structures 14 with the magnets being formed of coils or closed loops of electrical conductors held at cryogenic temperatures by liquid helium supplied from tanks 15 or any other suitable high strength magnets. The magnets 13 interact with guideway structures 16 positioned in supporting structure (concrete) 11 and as shown here are continuous strips of conducting metal preferably aluminum. A propulsion system for example a linear synchronous motor

represented by synchronous motor coils 18 provide the necessary driving forces. Enclosure 19 represents facility for providing climate control and services to the passenger portion of the vehicle.

The principle of levitation is well known and is not described here but it is seen that the opposed magnets and guideway strip are placed at an angle to the horizontal to provide lateral restoring forces. It will be seen that this could result in rolling instabilities that would be most undesirable.

FIG. 2 illustrates an arrangement according to the invention whose lateral stability (i.e., inherent restoring forces) can be obtained from a simple horizontal arrangement. This system would be much less expensive and easier to maintain and keep clear of dirt, snow, etc. The longitudinal portion of the real or equivalent magnetic currents 21 in magnets 13 are positioned such that when the vehicle is centered these lie outwardly in the horizontal sense of the edges of the continuous strip 16 fixed in guideway 11. It is known that if a magnet travelling over the surface of a semi infinite horizontal conducting sheet approaches the edge, there are produced forces on the magnet tending to propel it over the edge of the sheet. In the present case the reverse of this phenomenon is applied and if the magnets are forced horizontally off-center there is a restoring force tending to keep the magnets centered over the strip.

FIG. 3 shows an arrangement where the longitudinal portion of the real or equivalent magnetic currents in magnets 13 are arranged to extend outwardly of the horizontal portions 22 of conducting loops (or ladder arrangements) fixed in or on the upper surface of guideway structure 11. An examination of the force vectors involved will show that if the vehicle becomes off-centered for example if magnets 13 are moved laterally in relation to conductors 22 the forces or the magnets change such that there is a net restoring force tending to recenter the magnets and thus the vehicle.

FIG. 4 shows the reverse arrangement with real or equivalent magnet currents 22 outwardly of conductors 21 but still providing an inherent restoring force.

FIG. 5 is an arrangement similar to that of FIG. 2 with the conducting strips 16 shaped so that high currents can be accommodated in the outer portions. It has been realized that the eddy currents enclosed in the strip tend to concentrate at the outer edges. To achieve a less expensive continuous strip in conducting material it has been found that a shape with greater area cross-section at the outer edges with only a thin web in the central portions is to be preferred.

In the above description it has been assumed that the levitation and propulsion system are separate but systems that use same conductors for combinations levitation, guidance and propulsion can be envisaged and the present invention can be readily applied to such a composite arrangement.

I claim:

1. A magnetic levitation guidance system for levitated vehicles comprising:
  - a. first and second fixed parallel continuous metal

strip conductors mounted in parallel relation on a continuous guideway, each of said strip conductors having generally straight longitudinal edges and having a lateral cross-section providing increased current carrying area at the edges relative to the central portions of the strips,

- b. first and second sets of cryogenic current carrying coils or magnets on the vehicle positioned in relation to the fixed conductors such that on relative motion of the magnets in relation to the fixed conductors eddy currents are induced in the fixed conductors resulting in magnetic fields providing levitation forces on the vehicle.
  - c. the two longitudinal portions of the conductors or edges of the first set of magnets on the vehicle being positioned when the vehicle is over the guideway such that they lie outwardly in the lateral sense of the two edges of the first metal strip, such as to provide lateral restoring forces to the vehicle tending to return the vehicle to a central position, and
  - d. the two longitudinal portions or edges of the second set of magnets on the vehicle being positioned when the vehicle is over the guideway such that they lie outwardly in the lateral sense of the two edges of the second metal strips such as to provide lateral restoring forces to the vehicle tending to return the vehicle to a central position.
2. A magnetic levitation guidance system for levitated vehicles comprising:
    - a. first and second sets of continuous series of closed conducting loops or ladderway structures with each loop or ladderway having two longitudinal spaced portions mounted in parallel relation on a continuous guideway,
    - b. first and second sets of cryogenic current carrying coils or magnets on the vehicle positioned in relation to the fixed conducting loops or ladderways such that on relative motion of the magnets in relation to the fixed conductors eddy currents are induced in the fixed conductors resulting in magnetic fields providing levitation forces on the vehicle,
    - c. the two longitudinal portions of the conductors or edges of the first set of magnets on the vehicle being positioned when the vehicle is over the guideway such that they lie inwardly in the lateral sense of the longitudinal spaced portions of the first set of closed loops or ladderways such as to provide lateral restoring forces to the vehicle tending to return the vehicle to a central position, and
    - d. the two longitudinal portions or edges of the second set of magnets on the vehicle being positioned when the vehicle is over the guideway such that they lie inwardly in the lateral sense of the longitudinal spaced portions of the second set of closed loops or ladderways, such as to provide lateral restoring forces to the vehicle tending to return the vehicle to a central position.

\* \* \* \* \*