

[54] **HIGH PRESSURE JET-GROUTING METHOD**

[75] Inventors: **Yoshio Ichise; Akio Yamakado**, both of Tokyo; **Shoji Takano**, Yokohama, all of Japan

[73] Assignee: **Yoshio Ichise**, Tokyo, Japan

[22] Filed: **Nov. 3, 1971**

[21] Appl. No.: **195,196**

2,196,211	4/1940	Martman.....	61/36 R
2,403,643	7/1946	Dresser	61/36 R
3,243,962	4/1966	Ratliff	61/36 R
3,303,656	2/1967	Landau	61/11
3,391,544	7/1968	Daczko	61/63
3,608,318	9/1971	Levy et al.	61/36 R

Primary Examiner—Mervin Stein
Assistant Examiner—Alexander Grosz
Attorney, Agent, or Firm—Meyer, Tilberry & Body

[30] **Foreign Application Priority Data**
 Nov. 12, 1970 Japan..... 45-99168

[52] **U.S. Cl.**..... **61/36 R**

[51] **Int. Cl.**..... **E02d 3/00**

[58] **Field of Search**..... 61/36 A, 36 R, 63, 35

[57] **ABSTRACT**

A method and apparatus for high pressure jet-grouting which comprise inserting an injecting tube into the ground which has a nozzle disposed for directing a jet of a chemical containing a ground hardening agent at an angle inclined to the axial direction of the injecting tube. The jet of the chemical hardening agent is discharged through the nozzle at a velocity of 100-450 m/sec and at a pressure of 50-1000 kg/cm².

[56] **References Cited**
UNITED STATES PATENTS

1,411,057 3/1922 Miller..... 61/36 R

17 Claims, 6 Drawing Figures

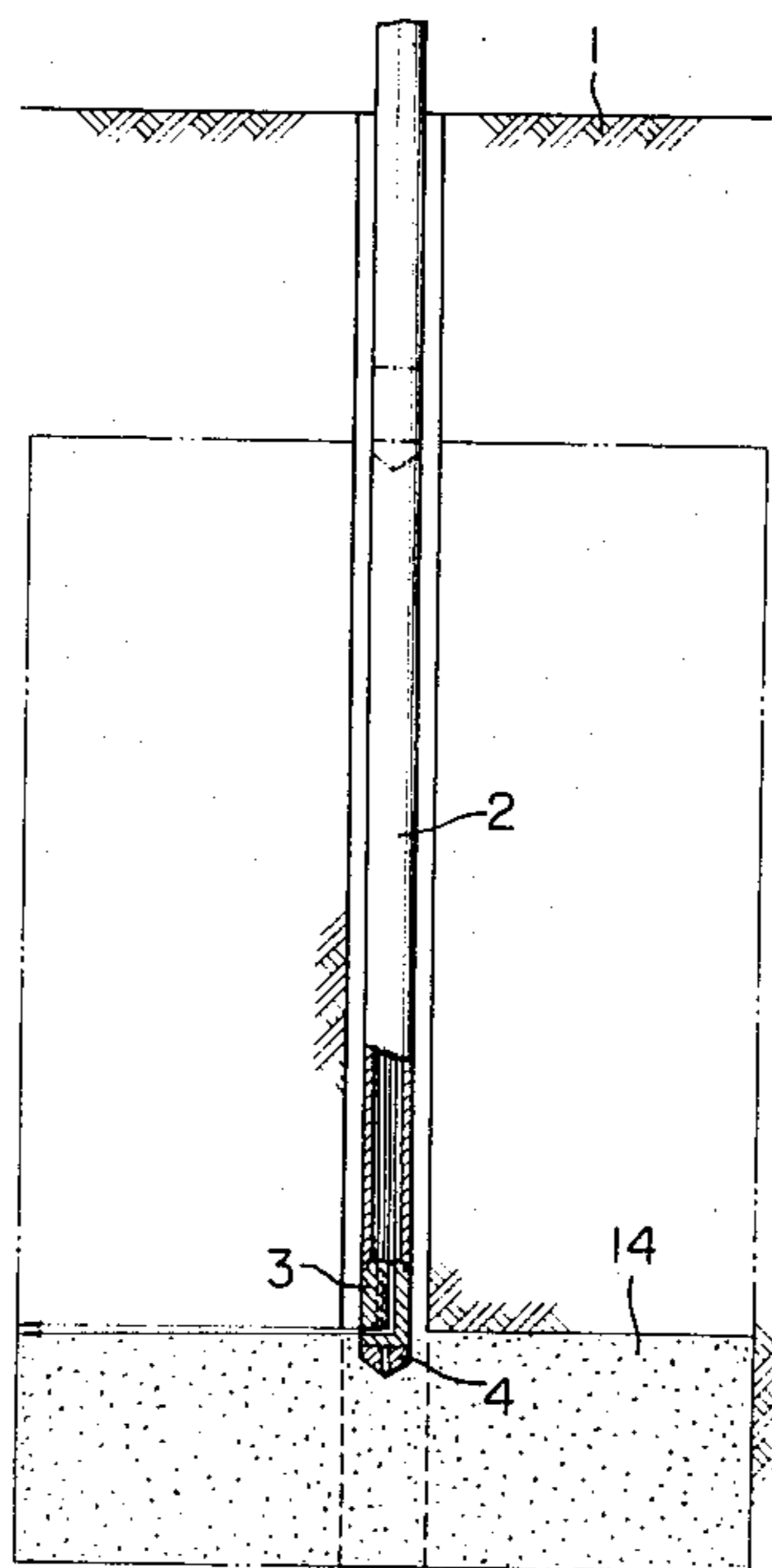

FIG. 1

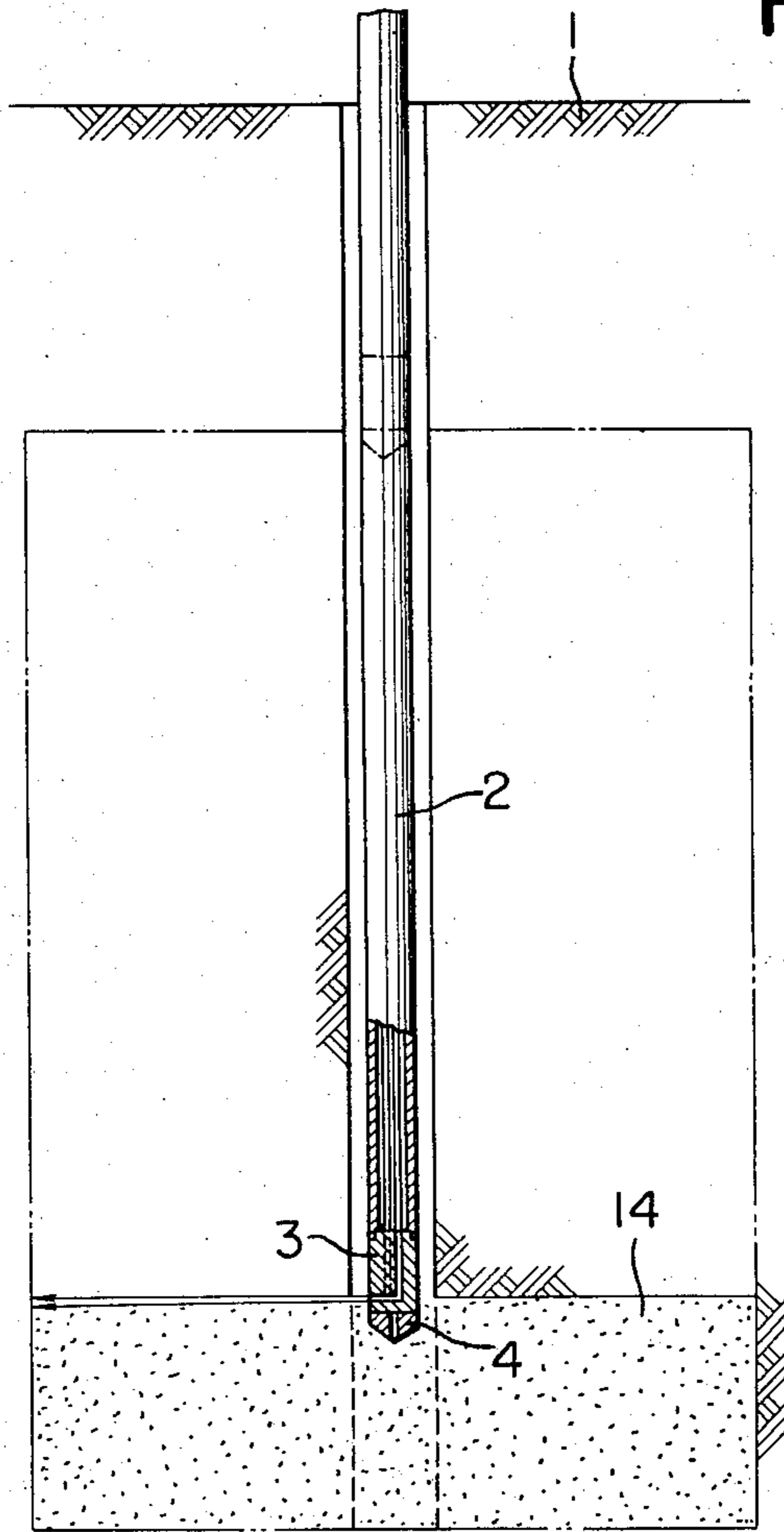

FIG. 2A

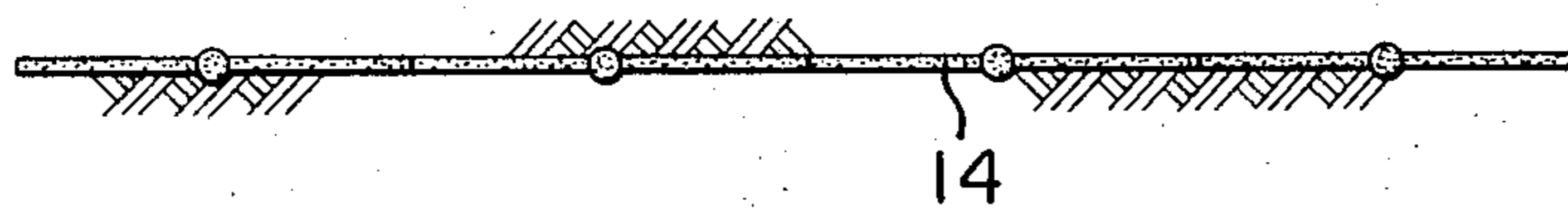

FIG. 2B



INVENTORS.
YOSHIO ICHISE
AKIO YAMAKADO
SHOJI TAKANO

BY
Meyer, Tilberry & Body
ATTORNEYS.

FIG. 3

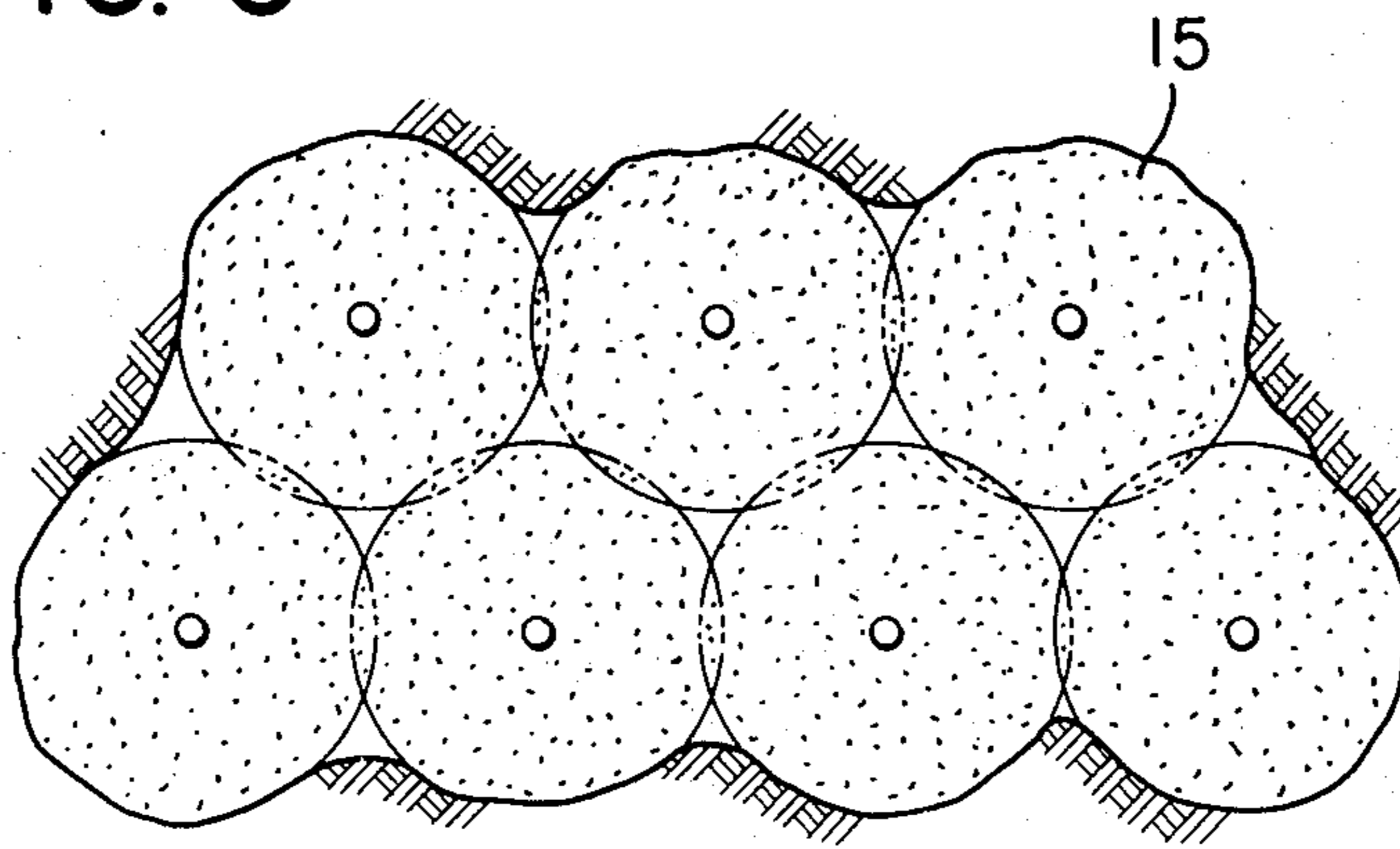
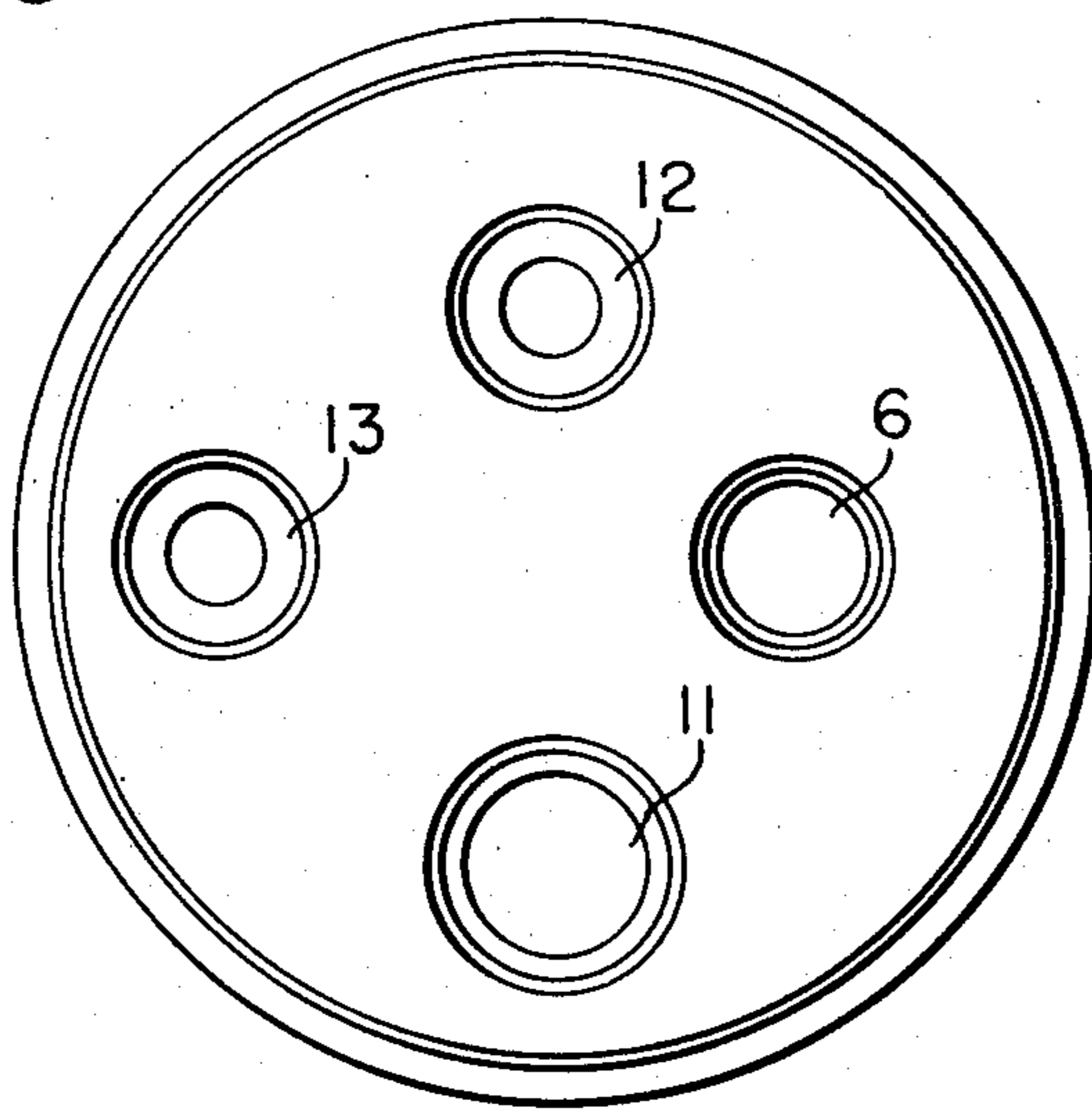

FIG. 5



INVENTOR.
YOSHIO ICHISE
AKIO YAMAKADO
SHOJI TAKANO

BY
Meyer, Tilberry & Body
ATTORNEYS.

FIG. 4

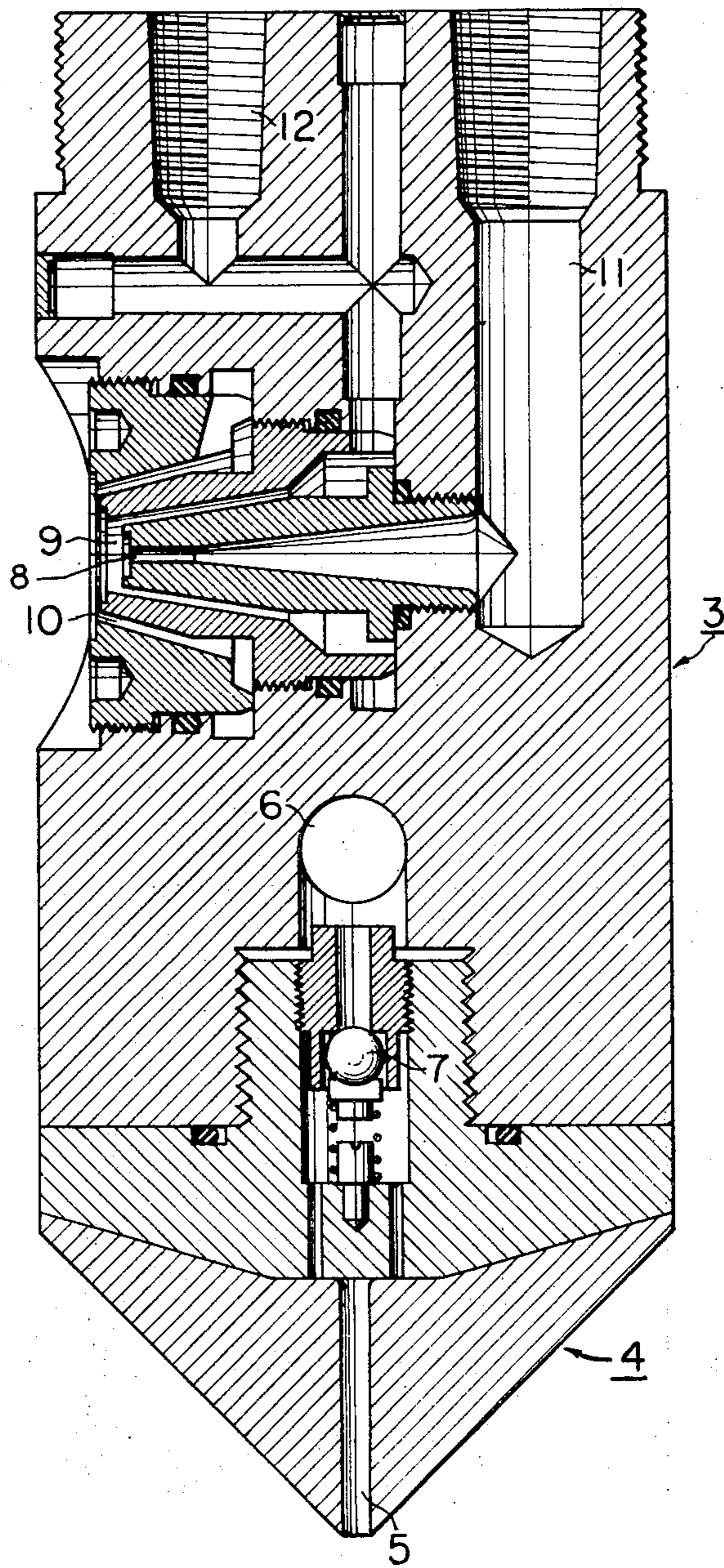

INVENTORS.
YOSHIO ICHISE
AKIO YAMAKADO
SHOJI TAKANO

BY

Meyer, Tilberry & Body
ATTORNEYS.

HIGH PRESSURE JET-GROUTING METHOD

DISCLOSURE

The present invention relates to high pressure grouting in an area of ground, a suitable chemical being injected for stabilizing the ground. More particularly the invention relates to forming a panel-like water-shielding or water-impervious wall having a relatively thin thickness.

Heretofore, in order to shut off the surface water of stratum consisting of sedimentary ground or cataclastic formation ground newer than tertiary period, a method has been employed to build a water shielding wall by injecting a chemical for ground hardening into the ground. In the prior method, injecting tubes were inserted into the ground at fixed intervals and were axially displaced. A chemical hardening agent as then injected through the tubes into the ground under pressure in the range of, for example, 1-30 kg/cm² in order to permeate the ground.

However, in an attempt to build elongated water-shielding walls that could be made by using a single injection process, the injection pressure was elevated to a higher level than the above mentioned permeation pressure. As a result, the chemical "ran away" in the direction where escape was made easy on the basis of the quality of the ground itself so that a water-shielding wall of an undesirable lumpy type having concave and convex portions was obtained. The above also resulted in the use of a quantity of chemical beyond expectation and in the formation of a wall of non-uniform thickness which had a tendency to be "washed away."

In forming water-shielding walls in both the perpendicular and horizontal directions to extend across an area of the ground, it has, therefore, been previously necessary to employ a plurality of the injecting tubes. This conventional method has had the inherent drawbacks that an efficiency of execution of work is not improved, the cost is increased and reliability in the execution of work is not obtained.

The present invention contemplates a new and improved method and apparatus which overcomes all of the above referred problems and others and provides a method and apparatus for high pressure jet grouting which is simple, efficient, and provides an improved finished work product.

In accordance with the present invention, there is provided a new method of high pressure jet grouting. The method comprises the steps of: inserting an injecting tube into the ground; providing a grouting flow nozzle in said injecting tube at an angle inclined to the axial direction of said tube; and discharging a jet of grouting through said nozzle at high pressure.

In accordance with another aspect of the present invention, the method further includes the step of discharging a jet of compressed air with the jet of grouting.

In accordance with another aspect of the present invention, the method also includes the steps of lifting and rotating the injecting tube during the discharging step.

In accordance with still another aspect of the present invention, there is provided an apparatus for high velocity grouting. The apparatus includes an injecting tube having a nozzle disposed therein at an angle inclined to the axis of the injecting tube for injecting a jet of grouting into the ground. Means are also provided

for continuously supplying a grouting material to the nozzle at high pressure.

The principal object of the present invention is the provision of a new and improved method and apparatus for high pressure jet-grouting.

Another object of the present invention is the provision of a new and improved method for high pressure jet grouting in which a panel like hardened layer of thin thickness may be formed from a predetermined amount of a grouting chemical.

Another object of the present invention is the provision of a new and improved method and apparatus for high pressure jet grouting which reduces the number of separate pieces of equipment required.

Still another object of the present invention is the provision of a new and improved method and apparatus for high pressure jet grouting which is readily adaptable to use in forming a plurality of different styles of underground water shielding walls.

Yet another object of the present invention is the provision of a new and improved method and apparatus for high pressure jet grouting which is simple and economical to employ.

The invention may take physical form in certain parts and arrangements of parts, a preferred embodiment of which will be described in detail in this specification and illustrated in the accompanying drawings which form a part hereof and wherein:

FIG. 1 is a cross sectional view showing a schematic arrangement wherein a water-shielding wall is formed in the vertical direction;

FIG. 2 is a schematic horizontal cross sectional view of continuous water-shielding wall extending vertically, view (A) showing a liner wall and view (B) showing a bent wall;

FIG. 3 is a cross sectional view showing a horizontally extending water-shielding wall;

FIG. 4 is a cross sectional view of the tip of an injection tube according to the invention; and,

FIG. 5 is a plan view of the arrangement shown in FIG. 4.

Referring now to the drawings wherein the showings are for the purposes of illustrating the preferred embodiment of the invention only and not for purposes of limiting same, the FIGURES show a chemical jet nozzle area generally designated 3 which is coaxially threadably received in one end of an elongated injecting tube 2. Threadably received on nozzle 3 and coaxial therewith is a water jet nozzle generally designated 4.

In jet nozzle 4, water is passed, under pressure, through tube 6 extending inside of and along injecting tube 2 to a jet opening 5. A one-way valve 7 disposed between tube 6 and jet opening 5 assures the prevention of counterflow. This valve may be of a general type previously known.

In the preferred embodiment of the invention, jet nozzle area 3 includes a pair of coaxial jet nozzles 8, 9 for supplying two liquid chemicals as will hereinafter become more fully apparent. Jet nozzle 8 is generally centrally located and communicates with tube 11 to receive a continuous supply of the main chemical liquid or ground hardening agent A. Jet nozzle 9 is disposed about and opens to the periphery of nozzle 8 and communicates with tube 12 to receive a continuous supply of a chemical liquid or ground hardening accelerator B for intermixing with liquid A as will hereinafter be described.

Jet nozzle area 3 also includes a third coaxial jet nozzle 10 disposed about both of nozzles 8, 9. Nozzle 10 is employed to direct a continuous flow of compressed air outwardly to the periphery of the liquid discharges from nozzles 8, 9 and communicates with tube 13 in order to receive the desired supply of compressed air.

It should be here noted that nozzles 8, 9 and 10 are threadably received in nozzle area 3 in order that they may be easily removed and/or replaced as may be necessary. It should be further noted that although the three jet nozzles are coaxial and extend perpendicular to the axis of injecting tube 2, other angles of inclination could be employed or the nozzles in the injecting tube in several stages.

A suitable method in inserting injecting tube 2 into the ground 1 is to first bore a hole and then insert the tube, or alternatively a jet of water discharged from jet opening 5 of jet nozzle 4 could be utilized to bore a hole and insert the tube in one operation.

The injection of the chemical may be carried out when the injecting tube reaches the predetermined depth under the surface. The chemical or grouting suitable may be drawn from the acrylamide series. However, a solution such as from the water glass series, lignin series or acrylates which have relatively shorter coagulation time may also be used. While in the preferred embodiment, the chemical is referred to as a two-liquid type; a one-liquid type may also be used with satisfactory results. In the claims, the general term "grouting" used to describe the material jetted into the ground is intended to include any and all types of grouting, chemicals, ground hardening agents, etc. usable in accordance with the invention.

The chemical or grouting is discharged at high pressure produced by a high pressure pump or other suitable means (not shown). Also, the compressed air is compressed to a high pressure by means of the pump and is discharged from the jet opening of the jet nozzle. In the case of a one-liquid type chemical, the high pressure jet of chemical from jet nozzle 8 carries a jet force so that the grouting can move forward following cutting of the sand and clay of the ground.

In the case of a two-liquid type chemical, the liquids mix while the sand and clay is being cut away and the mixture fills the excavated gap and subsequently hardens. The compressed air which has been discharged from nozzle 10 acts to exclude underground water and can substantially increase the jet distance of the jet flow of the chemical.

The pressure and flow rate of the liquid chemical and the pressure of the compressed air to be used in excavating the ground are different from each other according to the difference between the soft silt formation, conglomerate formation or cataclastic formation; however, the cutting length by the jet is usually found to be from 1 to 8 meters.

In order to provide such a cutting length, the pressure of the chemical is set to 50-1000 kg/cm² and the velocity of the jet of the chemical becomes 100-450 m/sec. The pressure of the chemical may be set to 1,000 kg/cm², but if it is set to below 50 kg/cm², the cutting effect may not be obtained. Also, the pressure of the compressed air may be set to a pressure that can exclude the underground water, and according to the depths involved the pressure may range from 3-7 kg/cm².

An example of the results obtained using the concepts of the subject invention is as follows. Injecting tube 2 was inserted into ground of loam formation in which underground water occurred following use of the jet water method for inserting the injecting tube. The grouting chemical was a resin solution from the acrylic series and was fed to jet nozzle area 3 at a pressure of 200 kg/cm² by means of a plunger pump in order to be discharged from the associated nozzle at a jet velocity of 180 m/sec. The compressed air discharged from nozzle 10 was supplied at a pressure of 5 kg/cm². About 1 hour following discharge and when the ground around the cutting gap was excavated, the chemical hardened substance has set to form a member having a thickness of between 9-15 mm and 700 mm long in the discharge direction.

Under similar condition and when injecting tube 2 was raised or withdrawn from its initial position at a low speed during discharge, a wall having a thickness of 7-18 mm was formed within the ground. This wall was integrally formed and continuous through the ground and is believed to have sufficient water-shielding properties.

As explained in the foregoing, when the chemical containing the ground hardening agent is discharged at a high-rate from its nozzle and the compressed air is discharged from its nozzle, the ground cutting function can be improved. Thus, a relatively long, thin wall can be provided.

When the injection operation is repeated using a plurality of injecting tubes 2 spaced along a line in the ground and by using the lifting method as hereinabove described, a continuous water-shielding wall 14 as shown in FIGS. 1 and 2 can be formed. (A) and (B) of FIG. 2 show the condition where the respective water-shielding walls are formed either linearly or in folded form.

When the injecting tube 2 is rotated and the injection is carried out as shown in FIG. 3, a horizontal water-shielding wall 15 or a continuous supporting layer of such walls is formed. Furthermore, when the rotation and lifting of the injecting tube 2 are simultaneously carried out, a column-like body is formed.

The invention has been described with reference to the preferred embodiment. Obviously, modifications and alterations will occur to others upon the reading and understanding of this specification. It is our intention to include all such modification and alteration insofar as they come within the scope of the appended claims or the equivalents thereof.

Having thus described our invention, we now claim:

1. A method of high pressure jet-grouting comprising the steps of inserting an injecting tube into the ground, discharging a jet of compressed air with a jet of grouting through a grouting flow nozzle inclined to the axial direction of said tube at a pressure high enough to cut the ground, and cutting the ground with said jet of grouting whereby the cut is filled with said grouting.

2. A method according to claim 1 in which the step of discharging said compressed air comprises discharging said air at a pressure in the range of between 3 to 7 kg/cm².

3. A method according to claim 1 further including the step of drawing said injecting tube from its position in the ground during said discharging steps.

4. A method according to claim 1 further including the step of rotating said injecting tube about its axial direction and drawing said injecting tube from its position in the ground during said discharging step.

5. A method according to claim 1 wherein said step of discharging grouting comprises discharging said grouting at a pressure in the range of between 50 to 1,000 kg/cm².

6. A method according to claim 1 wherein said step of discharging grouting comprises discharging said grouting at a velocity in the range of between 100 to 450 m/sec.

7. A method according to claim 1 including the step of boring a hole in the ground for receiving said injecting tube.

8. A method according to claim 2 further including rotating said injecting tube about its axial direction during said discharging step.

9. A method of high pressure jet-grouting comprising the steps of inserting an injecting tube into the ground and discharging a jet of compressed air together with a jet of grouting through flow nozzles inclined to the axial direction of said tube and cutting the ground with said jets of air and grouting whereby the cut is filled with said grouting.

10. A method according to claim 9 wherein the pressure of the compressed air and grouting jet cuts the

ground for a distance of between 1 to 8 meters.

11. A method according to claim 9 wherein said jet of compressed air is discharged outwardly around the periphery of said jet of grouting.

12. A method according to claim 9 wherein said jet of compressed air is discharged at a pressure in the range of 3 to 7 kg/cm².

13. A method according to claim 9 further including discharging two jets of grouting with one jet of grouting being discharged outwardly around the periphery of the other jet of grouting.

14. A method according to claim 13 wherein said jet of compressed air is discharged outwardly around the periphery of the outermost of said two jets of grouting.

15. A method according to claim 9 further including the step of rotating said injecting tube about its axial direction during said discharging step.

16. A method according to claim 9 further including drawing said injecting tube from its position in the ground during said discharging step.

17. A method according to claim 9 further including the step of rotating said injecting tube about its axial direction and drawing said injecting tube from its position in the ground during said discharging step.

* * * * *

30

35

40

45

50

55

60

65