

[54] **METHOD AND APPARATUS FOR PRODUCING METAL TUBES BY EXTRUSION OF A HOLLOW BILLET**

[75] Inventor: Akira Asari, Osaka, Japan
 [73] Assignee: Kobe Steel Company Ltd., Kobe, Japan
 [22] Filed: Nov. 18, 1971
 [21] Appl. No.: 200,002

[30] **Foreign Application Priority Data**
 Nov. 19, 1970 Japan..... 45-103030
 [52] U.S. Cl..... 72/255, 72/265, 72/370
 [51] Int. Cl..... B21c 23/00
 [58] Field of Search 72/255, 265, 370, 264, 72/266

[56] **References Cited**
UNITED STATES PATENTS
 3,191,413 6/1965 Stulen..... 72/266
 1,285,328 11/1918 Neuberth..... 72/264

FOREIGN PATENTS OR APPLICATIONS

370,627 4/1932 Great Britain..... 72/265
 395,906 7/1933 Great Britain..... 72/265

Primary Examiner—Richard J. Herbst
Assistant Examiner—Robert M. Rogers
Attorney, Agent, or Firm—Oblon, Fisher, Spivak, McClelland & Maier

[57] **ABSTRACT**

Metal tubes are produced by extruding a hollow billet through an annular die opening defined by a die and a movable rod-shaped mandrel having a larger length than the tube to be produced, and by feeding the mandrel rod through the die together with the tube as it is being formed so that the tube as produced has the mandrel rod disposed therein along its entire length, whereby damage to the inner surface of the tube caused by scratching due to relative movement of the mandrel therewith is avoided and tubes having improved inner surface characteristics are obtained.

6 Claims, 7 Drawing Figures

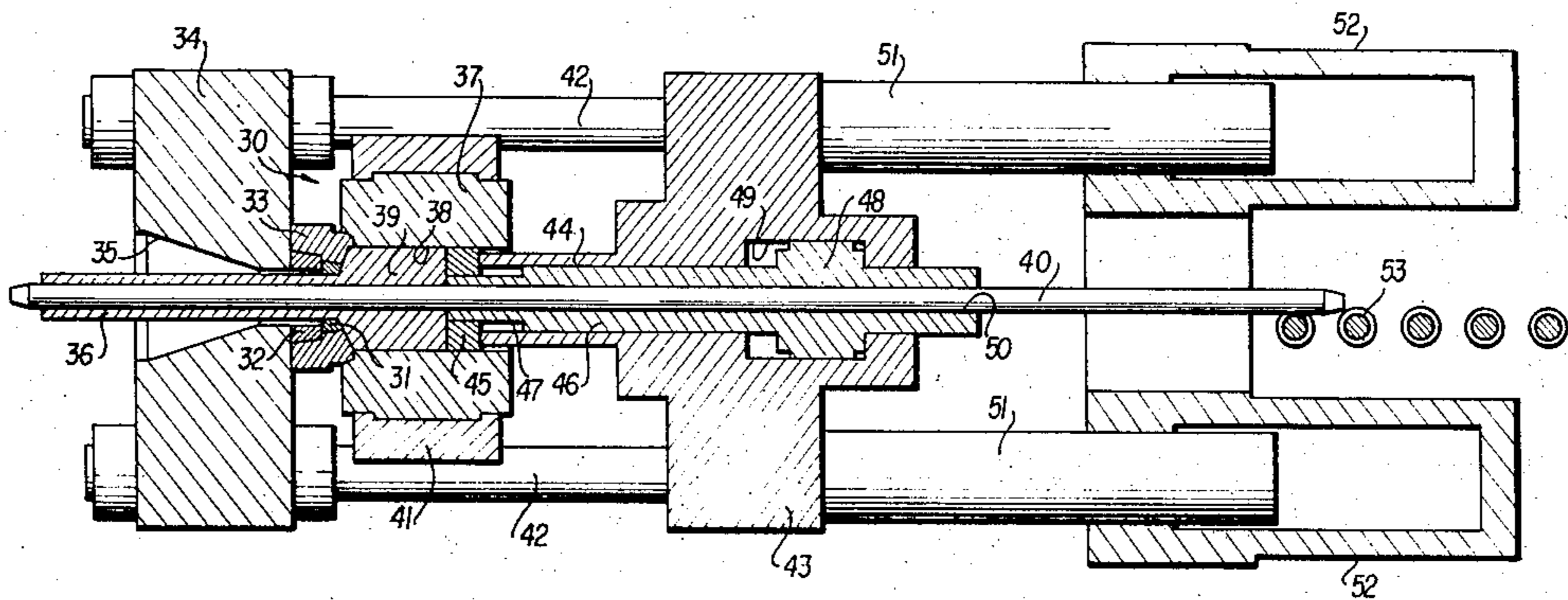

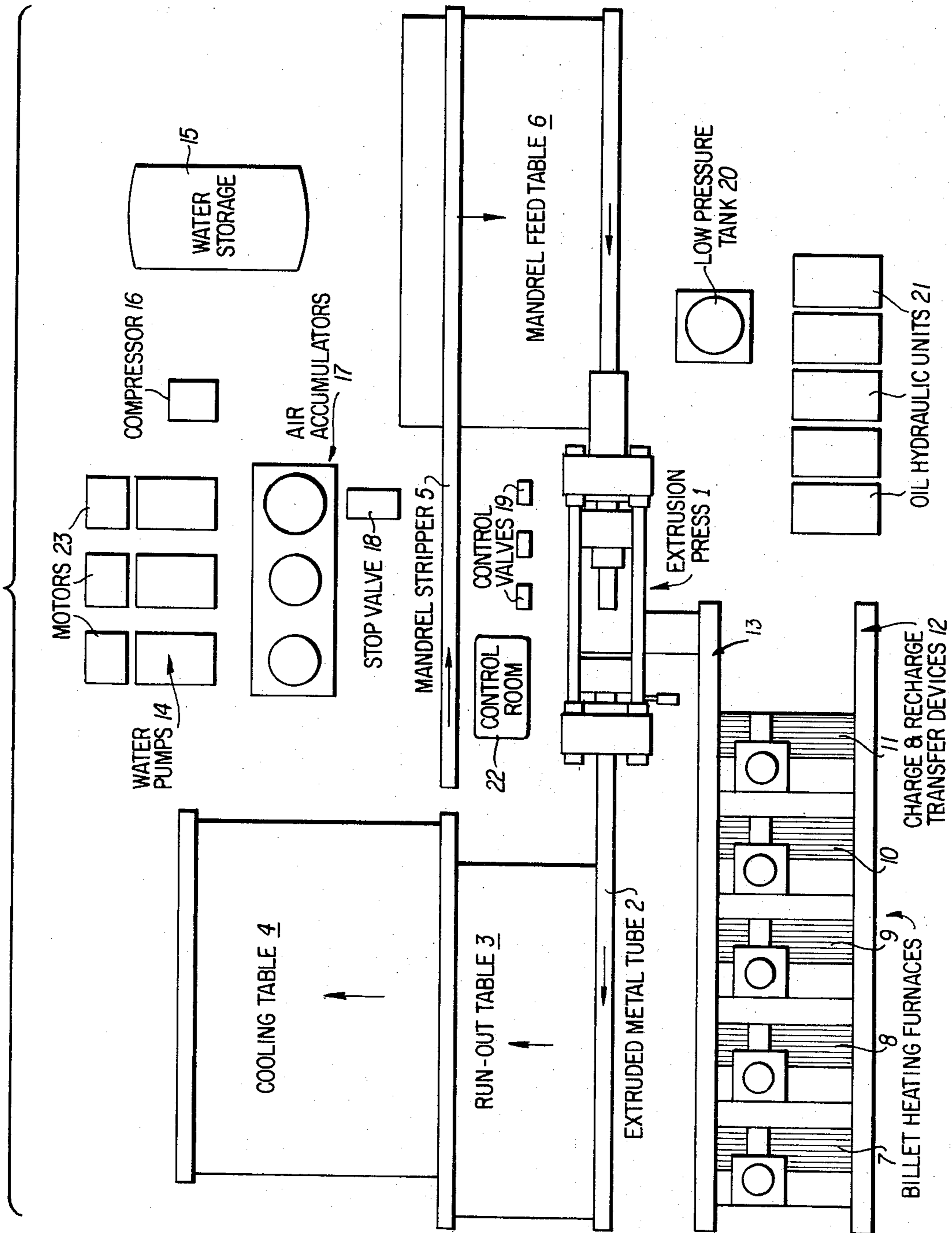

FIG. 1

INVENTOR.
AKIRA ASARI

BY
Oblon, Fisher & Spivak
ATTORNEYS

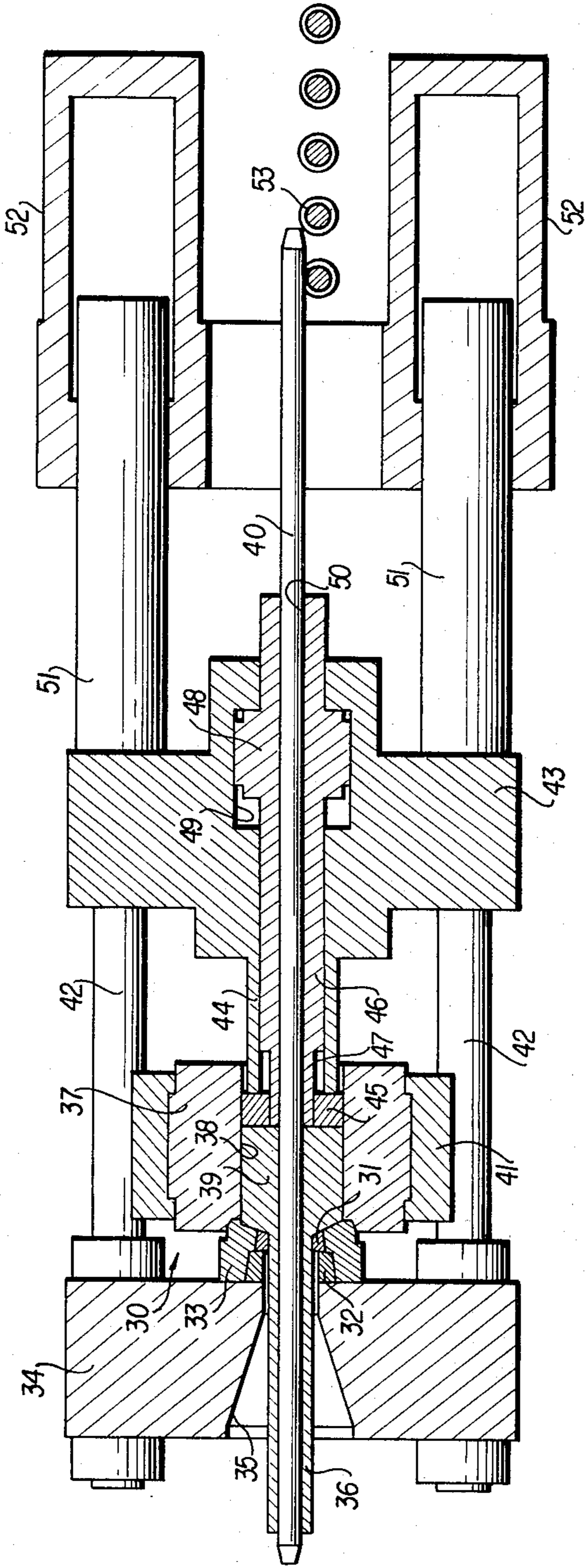

FIG. 2

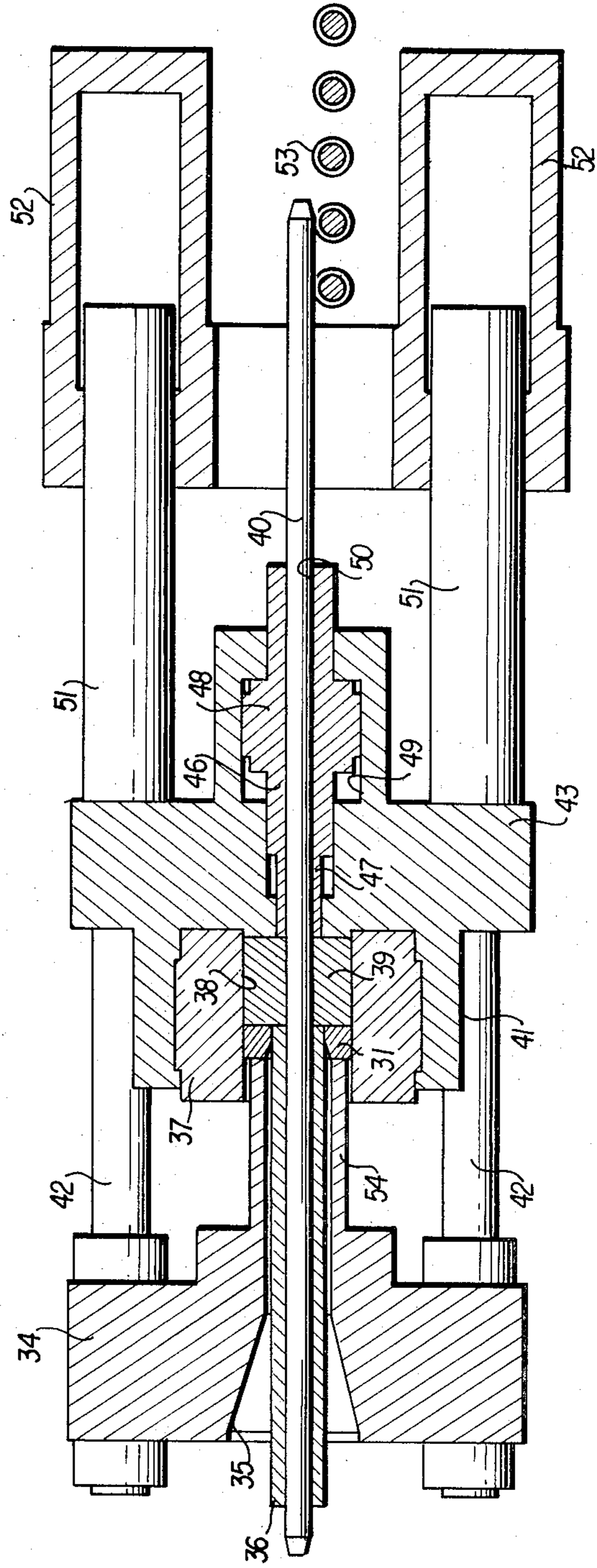

FIG. 3

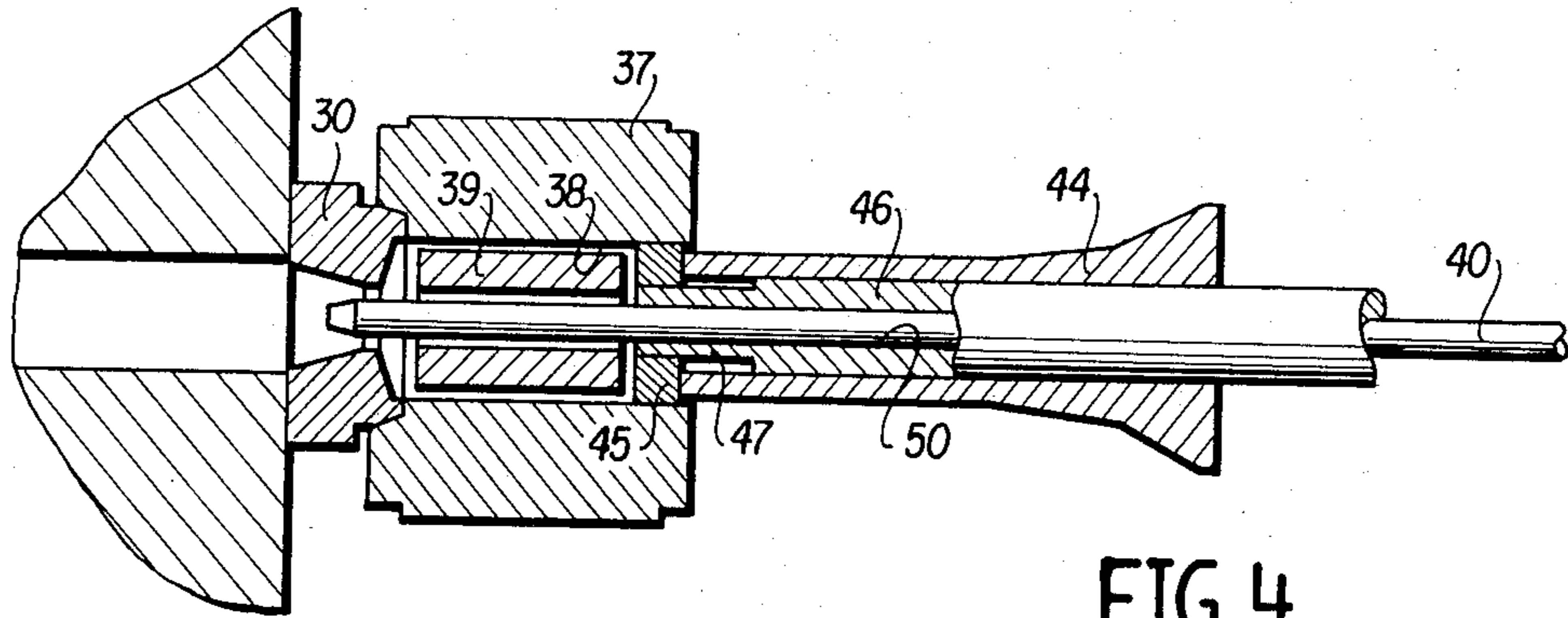

FIG. 4

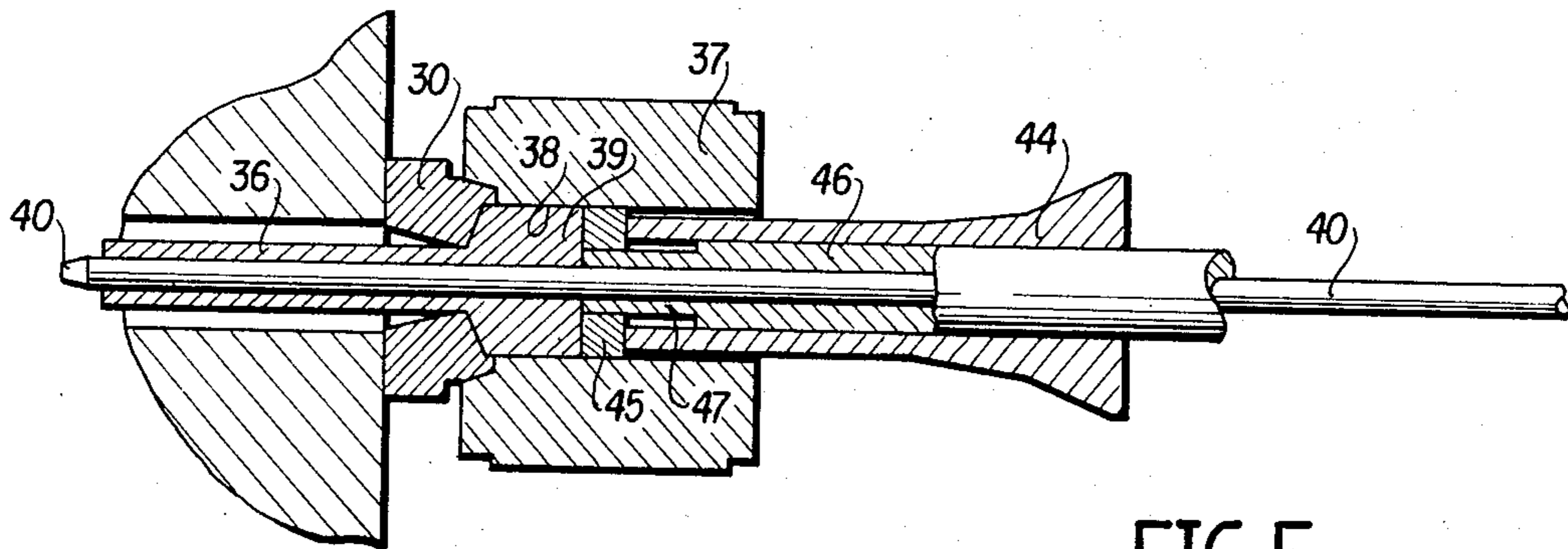

FIG. 5

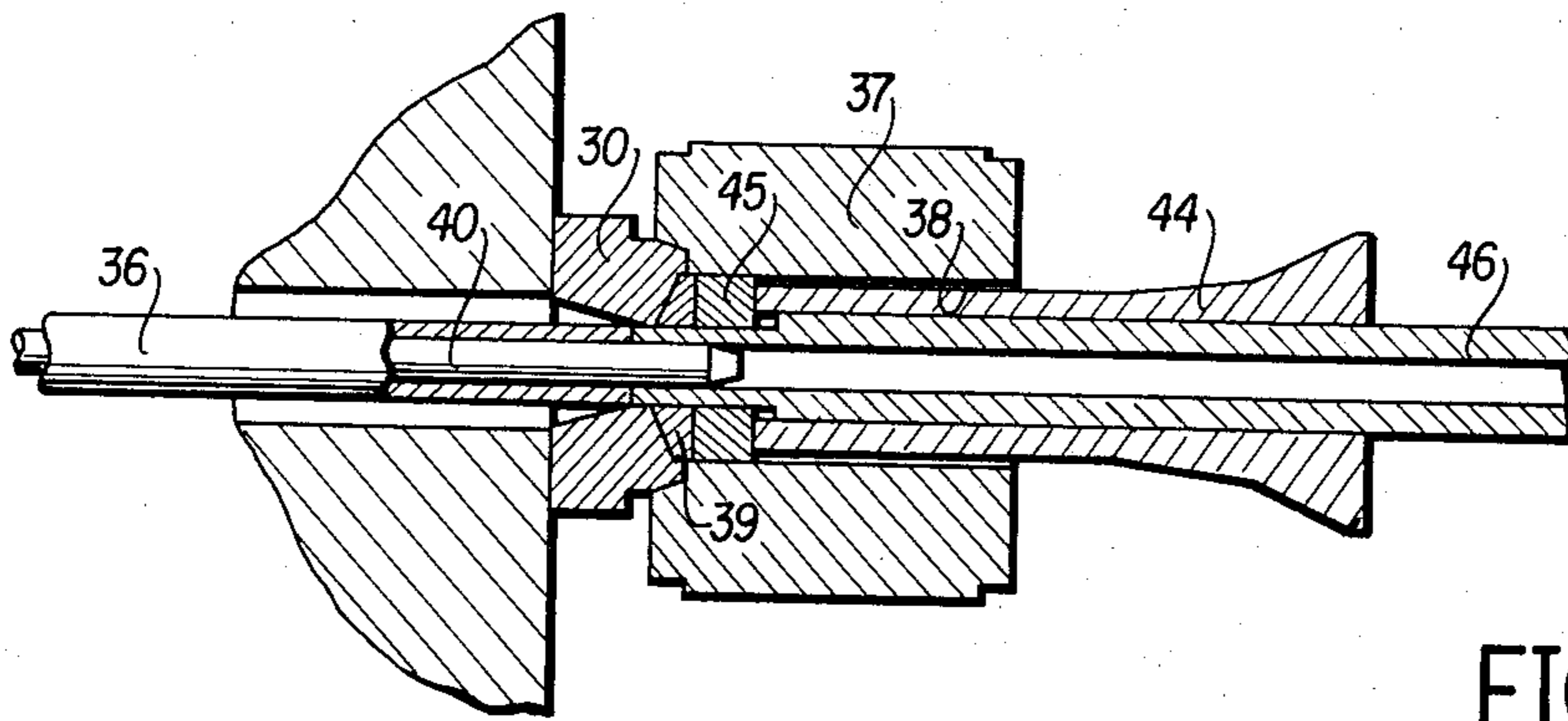

FIG. 6

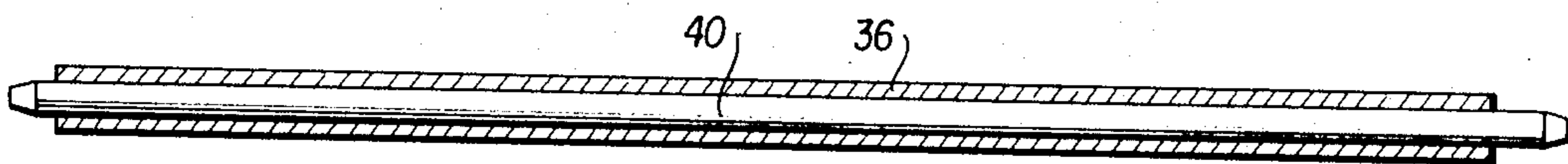

FIG. 7

METHOD AND APPARATUS FOR PRODUCING METAL TUBES BY EXTRUSION OF A HOLLOW BILLET

BACKGROUND OF THE INVENTION

1. Field of the Invention

This invention relates generally to the production of metal tubes and more particularly to a method and apparatus for producing metal tubes by extruding a hollow billet through a die and a cooperating mandrel.

2. Description of the Prior Art

The production of metal tubes by extruding a hollow billet through a die and a cooperating mandrel, wherein the die and the mandrel define an annular die opening through which the hollow billet is extruded to be formed into a tube having a cross-section corresponding to the annular die opening, is well known.

Conventionally, however, the mandrel which forms the inside surface of the tube moves relatively over the inside surface thereof as the tube is being formed by extrusion in such a scraping manner that the life of the mandrel is shortened due to frictional wear thereof. In addition, the finished condition of the inside surface of the tube is relatively poor because of scratches and other faults produced by the relative sliding with friction between the inside surface of the tube and the mandrel.

These scratches and other faults generally degrade the quality of the tubes and, in some cases, become a serious obstacle to the tubes being satisfactorily used for accomplishing the tasks being imposed thereon. For example, fuel encasing tubes designed for use in atomic reactors are required to be perfectly free from even minute scratches and similar related defects.

In order to avoid these disadvantages of former methods of extruding metal tubes, one common practice is to supply a lubricant to the boundary of the billet and the mandrel, with the lubricant being selected from any one of a number of suitable materials according to the material from which the billet is constructed, such as, for example, glass powder for billets which are made of steel or titanium, zirconium or aluminum alloys.

However, even with the use of a lubricant, as described above, it is very difficult to completely avoid the generation of scratches or other faults on the inside surface of tubes being formed in this manner, especially in the case of tubes of hard metals such as stainless steel, titanium or zirconium alloys, and the like. Therefore, in the production of such metal tubes by this conventional extrusion process, manufacturers have been compelled to maintain very strict control and supervision during the procedure in order to provide tubes having satisfactory inside surface conditions.

Furthermore, when a lubricant is used in the extrusion process, relatively complicated methods and devices are required for applying the lubricant to the boundary of the hollow billet and the mandrel, as well as for removing the layer of the lubricant remaining on the inside surface of the tubes being produced, especially when glass powder is used as the lubricant. These complicated procedures and the complex apparatus associated therewith which are tied in with the use of a lubricant adversely affect the productivity of an extrusion plant and thereby increase the cost of the products. Thus, while it has heretofore been possible to successfully produce metal tubes of the character described having adequate inner surface qualities, the

methods which have necessarily been resorted to have not been altogether satisfactory for various reasons.

SUMMARY OF THE INVENTION

Accordingly, it is a primary object of the present invention to provide a method and apparatus for producing metal tubes by extruding hollow billets through a die opening with the cooperation of a mandrel, wherein, however, the generation of scratches or other faults on the inside surface of the tube being formed due to relative frictional sliding motion between the tube and the mandrel is effectively avoided.

Another object of the present invention is to provide a method of producing metal tubes by extruding a hollow billet through a die with the help of a cooperating mandrel, which is not complex and does not require strict control, yet is capable of producing such tubes having inner surface characteristics of improved quality.

Still another object of the present invention is to provide an apparatus for practicing the method described immediately hereinbefore.

The foregoing and other objects are attained, according to one aspect of this invention, by an improved method of producing metal tubes comprising the steps of preparing a hollow billet having a central through opening of predetermined dimensions, extruding the hollow billet through an annular die opening defined by a die and a movable rod-shaped mandrel having a length greater than that of the tube being produced, feeding the mandrel rod through the die in accordance with the extrusion of the tube, and removing the mandrel rod from the tube after the tube has been completely extruded.

According to this invention, since the mandrel which cooperates with the die to define an annular opening through which a tube is extruded from a hollow billet is a rod of a greater length than the tube being produced and is fed through the die together with the tube as it is extruded from the die, such that the tube is always accompanied by the mandrel rod, substantially no relative sliding occurs between the inside surface of the tube and the mandrel over the whole length of the tube, and thereby scratches or other faults on the inside surface of the tube due to such relative sliding or friction between the tube and the mandrel are substantially avoided. Thus, tubes produced by the method of this invention have a very high quality of inside surface characteristics.

Since relative sliding between the tube and the mandrel is prevented, the extrusion is performed more smoothly and with less power than heretofore required for the conventional extrusion processes. Furthermore, the mandrel is relieved from severe frictional sliding under relatively high temperatures over the inside surface of the tube being formed, so that the life of the mandrel rod is substantially longer than previous mandrels employed in the prior devices and techniques.

By employing a number of the mandrel rods in cooperation with an extrusion press, it is possible to construct a circuit for the extrusion processes through which the mandrel rods are circulated, wherein the extrusion press can be operated essentially at its highest rate with no regard to the problems usually concerning operators of apparatus operating under the former processes, such as withdrawing, cooling or changing of the mandrels. Thus, it is possible with the present in-

vention to obtain a high productivity in the extrusion plant.

Furthermore, since it is not necessary either to supply or remove lubricant as required in the former practice, the extrusion plant for carrying out the process according to this invention is very simplified and can readily be automated, to thereby further improve the productivity of the plant.

BRIEF DESCRIPTION OF THE DRAWINGS

Various other objects, features and attendant advantages of the present invention will be more fully appreciated as the same becomes better understood from the following detailed description when considered in connection with the accompanying drawings, wherein like reference characters designate like or corresponding parts throughout the several views, and in which:

FIG. 1 is a plan view schematically showing the layout of a tube extrusion plant for practicing the method of this invention;

FIG. 2 is a longitudinal section of essential parts of an extrusion press for practicing the method of this invention;

FIG. 3 is a longitudinal section of another embodiment of an extrusion press; FIGS. 4, 5 and 6 show the die portion of the extrusion press shown in FIG. 2, respectively in three different phases of the extrusion process; and

FIG. 7 shows a tube just extruded according to the method of this invention, having a mandrel rod still disposed therein.

DESCRIPTION OF THE ILLUSTRATED EMBODIMENTS

Referring now to the drawings, and more particularly to FIG. 1, there is shown an example of a layout of a tube extrusion plant designed for practicing the method of this invention, wherein a billet extrusion press 1 as explained in detail hereinbelow is provided for extruding a tube 2 therefrom in the state in which a mandrel rod is yet disposed therein onto a runout table 3. The tubes placed on the table 3 are then transferred to a cooling table 4, where they may be cooled for a sufficient period of time to attain a required temperature without regard to the operation cycle of the extrusion press 1. Next, the cooled tubes 2 are fed to a mandrel stripper 5 of the push-bench or reeler type, which itself is known in the art.

The strippers 5 of the character described are conventionally used to draw out a core or other rod-like element from a tubular element, and generally accomplish their purposes without any difficulty and without causing scratches or other faults on the inside surface of the tubular element. The stripper of the reeler type, which employs pairs of cooperating skewed rollers, especially can be favorably employed for the present purpose of drawing the mandrel rod out from the extruded tube, by arranging a number of pairs of cooperating skewed rollers corresponding to the length of the tube.

After the mandrel rods have been removed, the tubes 2 are transferred from the mandrel stripper 5 to a suitable product storing station, not shown, while the mandrel rods are returned to a mandrel feed table 6, where they are further cooled and prepared for their next use in the extrusion process.

In the layout drawing schematically shown in FIG. 1, other equipment related to the billet extrusion press 1 are shown, such as billet heating furnaces 7, 8, 9, 10 and 11, a transfer device 12 for charging billets into the billet heating furnaces and another transfer device 13 for discharging the billets from the furnaces and feeding them to the billet extrusion press 1. A water pump 14 is provided for cooling the extruded tubes, mandrels and other equipment. Other parts of the plant which are shown include a water storage tank 15, a compressor 16, compressed air accumulators 17, a main stop valve 18, control valves 19, a low pressure tank 20, oil hydraulic units 21, a control room 22 and motors 23.

The manner of extruding the tubes from the billet at the billet extrusion press 1 is shown in the subsequent figures of the drawings. FIGS. 2 and 3, for example, show the state of different embodiments of extrusion presses wherein the extrusion of the tube has been initiated and is in progress.

In the billet extrusion press shown in FIG. 2, the reference numeral 30 generally designates a die assembly composed of a die 31 and a die packer 32 being housed in a die holder 33 and directly abutting on a press platen 34 having a central opening 35 through which an extruded tube 36 is fed out. Adjacent the die holder 33 there is provided a billet container 37 defining a billet chamber 38 in which is charged a hollow billet 39 being preformed to present a central opening which is adapted to allow penetration of a mandrel rod 40 there-through. The billet container 37 is supported by a container holder 41, which in turn is supported by one end of a pair of press columns 42 mounted on the platen 34. The columns 42 guide a cross head 43 having a stem portion 44 extending therefrom to be received in the billet chamber 38 for applying a compression force to the billet 39 charged therein through a disk 45. The central portion of the crosshead 43 is constituted as a piston-cylinder assembly including a movable element 46 presenting a shear mandrel 47 at its forward end and a piston 48 at its rear portion, which is disposed in a cylinder chamber 49 formed in the crosshead 43 for driving the movable element 46 with respect to the crosshead. Along the axis of the movable element 46, there is formed a through opening 50 adapted to allow feeding of the mandrel rod 40 therethrough. The crosshead 43 is movable along the columns 42 by rams 51 being actuated by supplying pressure to cylinders 52, and can be retracted to open the billet chamber 38 for charging a billet therein or moved forward to apply a compression force to the billet charged in the billet chamber. Reference numeral 53 designates a series of mandrel transfer rollers which carry the mandrel rod 40 and feed it according to the progress of the extrusion process.

The billet extrusion press shown in FIG. 3 is almost identical with the press shown in FIG. 2, except that in the press shown in FIG. 3, the billet container 37 is carried by the crosshead 43 through the container holder 41, which in this case is integrally formed as a part of the crosshead 43, and the die 31 is supported by a stem portion 54 projecting from the platen 34 in a manner that it is receivable in the forward end of the billet chamber 38.

The difference in the extruding operations of the presses shown in FIGS. 2 and 3 is that in the former press, the billet 39 is slid within the billet container 37

as the extrusion proceeds, while in the latter press, the billet 39 is kept substantially unmoved with respect to the billet container 37, and the die 31 is slid over the wall of the billet chamber 38.

FIGS. 4 to 6 show the starting, intermediate and ending conditions, respectively, of an extrusion process being carried out with the press shown in FIG. 2.

In the beginning, the billet 39 is charged in the billet chamber 38 with the crosshead 43 first being sufficiently retracted to open the chamber 38, and then the disk 45 is engaged and the crosshead 43 is moved forward to advance the disk 45 to be in close contracting relation with the billet. In this condition, the shear mandrel 47 is so retracted with respect to the stem portion 44 of the crosshead that it applies no shearing force to the billet. Next, the mandrel rod 40 is fed through the opening 50 of the movable element 46 in the crosshead 43 and the central opening of the billet 39 until the forward end thereof just penetrates the opening in the die assembly 30, to attain the starting position shown in FIG. 4.

Now the cylinders 52 are actuated to advance the crosshead 43 and apply a compression force to the billet 39, whereby the billet is extruded through the annular opening defined by the die assembly 30 and the mandrel rod 40 to form the tube 36. As the tube 36 is being formed and fed out through the die opening, the mandrel rod 40 accompanies the tube 36 with no substantial sliding motion occurring therebetween, and it also is fed out of the die opening as shown in FIG. 5, or FIGS. 2 and 3, wherein the annular die opening at each instant is provided by the die inner periphery and each corresponding portion of the mandrel rod.

When a predetermined length of the tube has been extruded, the cylinder 49 in the cross head 43 is actuated to advance the shear mandrel 47 with respect to the stem portion 44 and into the die opening, as shown in FIG. 6, whereby the end of the tube 36 is cut off from the remaining billet 39 which is disposed as a discard.

As a result of the extrusion process described above, there is obtained a tube 36 having the mandrel rod 40 extending throughout the entire length thereof, as shown in FIG. 7. These tubes, including the mandrel rods, are cooled and supplied to the mandrel stripper as described above and are relieved of the mandrels without being caused any substantial fault on the inside surface thereof.

Obviously many modifications and variations of the present invention are possible in light of the above teachings. It is to be understood, therefore, that within the scope of the appended claims, the invention may be practiced otherwise than as specifically described herein.

What is claimed as new and desired to be secured by letters patent of the united states is:

1. A method of producing metal tubes by extruding a hollow billet through a die with the cooperation of a mandrel, comprising the steps of:

- preparing a hollow billet having a central through opening of predetermined dimensions;
- applying an external compression force to said hollow billet in an axial direction thereof across its annular cross-section for extruding said hollow billet through an annular die opening defined by a die

and a rod-shaped mandrel having a greater length than that desired for a tube being produced; feeding said mandrel rod through said die with said tube being extruded so that substantially no relative motion occurs between said tube and said mandrel rod;

cutting the rear end of the tube from the remaining billet by shearing in the axial direction of said tube as said billet is being extruded through said die; and

removing said mandrel rod from the said tube after said tube has been completely extruded.

2. A method according to claim 1, further comprising:

- charging said hollow billet in a cylindrical chamber axially connected to said die opening; and
- moving said hollow billet with respect to the wall of said cylindrical chamber as a whole while applying said external compression force as the extrusion proceeds.

3. A method according to claim 1, further comprising:

- charging said hollow billet in a cylindrical chamber axially connected to said die opening
- maintaining said hollow billet substantially stationary with respect to the wall of said cylindrical chamber as a whole while applying said external compression force as the extrusion proceeds.

4. An apparatus for producing metal tubes by extruding a hollow billet through a die with a cooperating mandrel, comprising:

- a die having an opening therein;
- a billet container having a cylindrical chamber for receiving a hollow billet;
- means for supporting said billet container and said die so that said die opening and said cylindrical chamber are axially connected;

- a rod-shaped mandrel of greater length than that desired of a tube to be produced being movably supported for movement in an axial direction through said billet chamber and said die opening for defining an annular opening between said die and said mandrel;

- means for applying an axial compression force to a billet in said cylindrical chamber for extruding said billet through said annular opening and moving said rod-shaped mandrel therethrough with said tube being extruded; and

- a shear mandrel being movable within said means for applying an axial compression force to said billet for applying a shearing force to an inner peripheral portion of said hollow billet in said cylindrical billet chamber as the same is being extruded through said annular opening.

5. An apparatus according to claim 4, wherein said die and said billet container are firmly connected together and said compression force applying means is an actuator having an annular stem receivable in said cylindrical billet chamber.

6. An apparatus according to claim 4 wherein said die is movably received in said cylindrical billet chamber and said billet container is axially movable by said axial compression force.

* * * * *