

[54] ELECTRICAL CONNECTORS AND METHOD OF MAKING SAME

[76] Inventors: Sandiford Ring; Russell K. Ring, both of P.O. Box 14666, Houston, Tex. 77021

[22] Filed: May 1, 1972

[21] Appl. No.: 249,359

[52] U.S. Cl. 339/61 R, 339/278 R

[51] Int. Cl. H01r 13/52

[58] Field of Search 339/59-61, 278

[56] References Cited

UNITED STATES PATENTS

3,711,818 1/1973 Swehla 339/60 C

FOREIGN PATENTS OR APPLICATIONS

1,111,347 4/1968 Great Britain 339/61 R

Primary Examiner—Joseph H. McGlynn
Attorney, Agent, or Firm—Ralph R. Browning, C. James Bushman

[57] ABSTRACT

An electrical connector for subsurface use under conditions of high temperature and pressure, said connector, comprising a male member and female member, said male member employing a sealing annulus disposed between adjacent refractory sleeves, the annulus being bonded to the metal jacket of the male member, to the refractory sleeves and to the conductive pin.

13 Claims, 6 Drawing Figures

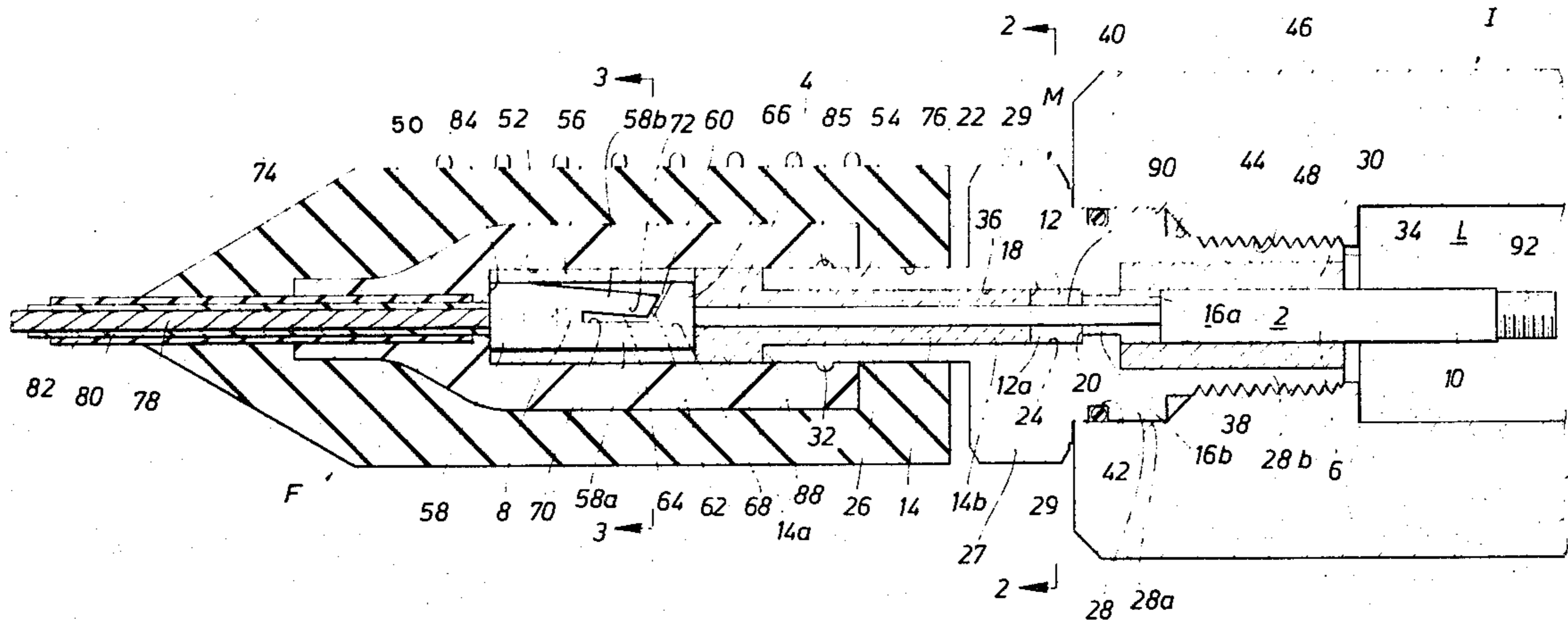

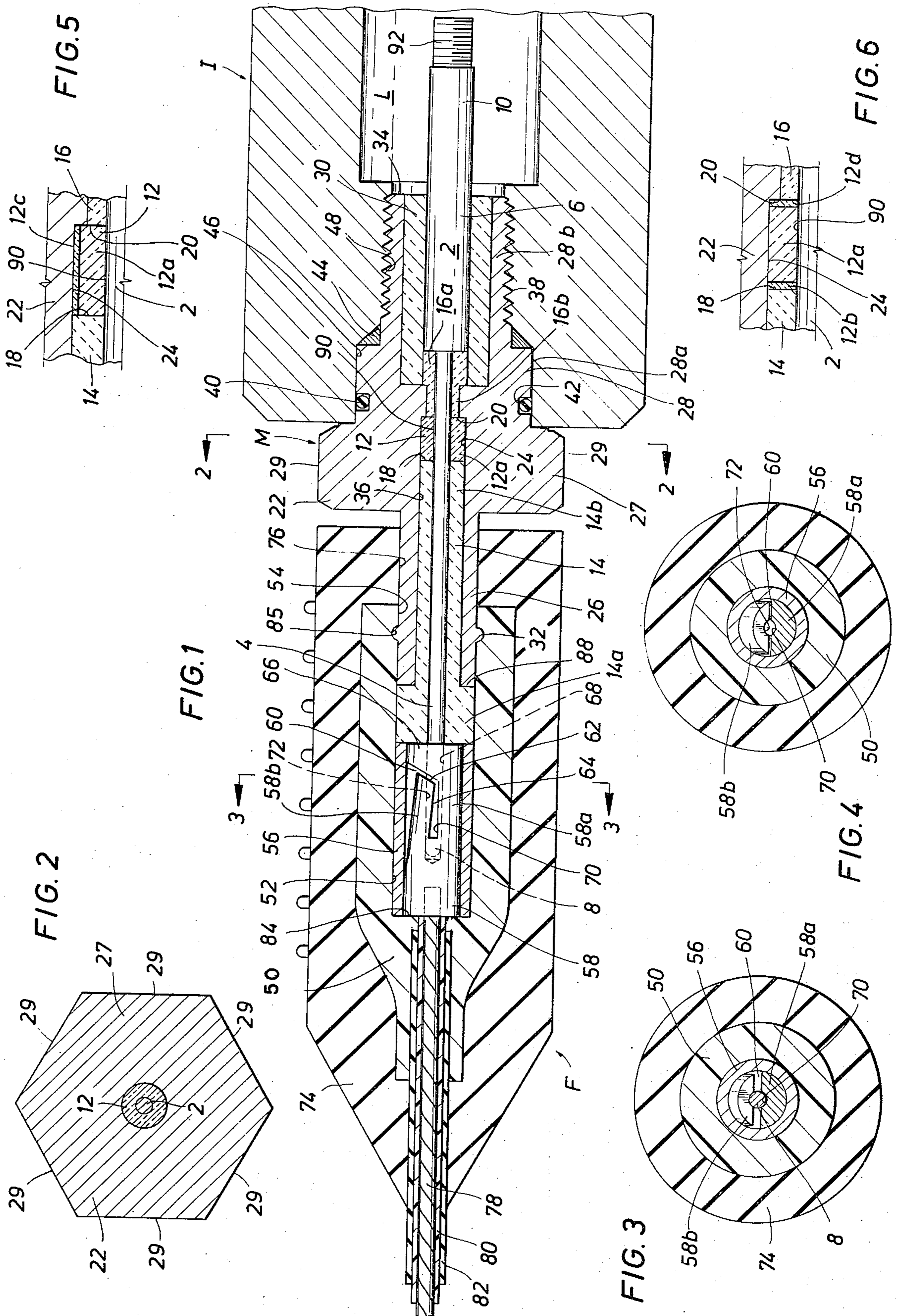

ELECTRICAL CONNECTORS AND METHOD OF MAKING SAME

BACKGROUND OF THE INVENTION

1. Field of the Invention

The present invention relates to electrical connectors for use in adverse environments and particularly for use in connecting wires to underground and/or underwater instruments so that electrical signals can be relayed to the surface. Such equipment is used in seismic exploration such as for example in searching for oil and other minerals. Prior to about 1965, drilling for oil was limited to depths of approximately 20,000 feet. At these depths, temperatures seldom exceeded 400° F. More recently, however, drilling to depths in excess of 20,000 feet has become common. At these greater depths temperatures often exceed 500° F. These adverse temperature conditions are encountered not only in oil exploration drilling but are found as well in wells used to monitor underground nuclear explosions and in other applications. Moreover, in underwater exploration, connectors capable of withstanding high pressures are absolutely necessary.

2. Description of the Prior Art

A typical connector of the type to which the invention pertains includes a male member and female member. The female member comprises a lead wire in contact with a conductive element which is generally surrounded by a sheath of elastomeric material. The male member comprises a conductive pin, the central portion of which is covered by an insulating material which in turn is encased in a metal jacket. One end of the pin engages the conductive element in the female member and the other end extends into the instrument housing.

Connectors of the type described which may be satisfactory at depths of 20,000 feet or less and temperatures of 400° F or less, present problems if used at greater depths and higher temperatures. One problem is that the organic based insulators such as the elastomeric sheaths of the wires and female members become carbonized and useless at temperatures in excess of about 400° F.

A second, more severe problem involves the male member. It has been recognized that ceramics of suitable refractory materials which can withstand high temperatures, might be useful as insulating materials, for example between the pins and the metal jackets of the male members. However, if the coefficient of thermal expansion of a metallic part, e.g., the jacket, of such a male member is not compatible with that of the ceramic or refractory portion, the ceramic may crack at high temperatures as it and the jacket expand at different rates. Thus, where ceramics made from refractory materials have been used heretofore as insulators in the male members of such connectors it has been necessary either to leave the ceramic and metal parts unfused and therefore not leakproof or, where the metal and ceramic parts were fused to render the member leakproof, to choose metals and ceramics having compatible coefficients of thermal expansion. This severely limits the types of materials which may be used. Furthermore, the metals which are compatible with the ceramics are often unsuitable for underground or underwater use because of corrosion problems posed by

the alkalies and acids found in subsurface environments.

SUMMARY OF THE INVENTION

5 It is therefore an object of the present invention to provide an electrical connector having fused metallic and ceramic components whose coefficients of thermal expansion are not necessarily compatible.

10 It is a further object of the present invention to provide connectors in which a greater variety of metals may be used in fused combinations with ceramic insulators.

15 Another object of the present invention is to provide a method for making an improved male member for an electrical connector.

20 It is a further object of the present invention to provide a male member for an electrical connector having an annulus of sealing glass surrounding the pin between a pair of refractory coverings and bonded to the refractory coverings, to the pin, and to a metallic jacket.

25 Still another object of the present invention is to provide a female member for an electrical connector having an outer elastomeric sheath and a temperature resistant inner polymeric sheath with means for sealing between said inner sheath and the male member.

30 In a connector according to the present invention the male member comprises a conductive pin, a portion of which is circumferentially embraced by a sealing annulus comprised of compression glass. Portions of the pin adjacent the annulus are circumferentially surrounded by refractory coverings or sleeves which are bonded to the glass annulus and fused to the pin, the annulus being bonded to the pin as well.

35 A jacket of metal circumferentially surrounds the annulus and those portions of the refractory coverings which are directly adjacent the annulus. During production the jacket is caused to shrink around the refractory coverings and the glass annulus and is bonded to the glass annulus and fused to the refractory covering. The seals formed between the glass annulus and adjacent surfaces of the refractory coverings, pin and jacket cooperate with other features of the connector to prevent leakage from the high pressure area outside the connector to the low pressure area in the instrument housing.

40 In one form of the invention, when the metal jacket has a thermal coefficient of expansion incompatible with that of the compression glass usually employed to form the annulus, the glass sealing annulus is comprised of two components — an inner core of the compression glass and an outer, relatively thin coating of a glass having thermoplastic properties compared to the inner core and located between the core and the jacket.

45 In another form of the invention, when the glass sealing annulus is comprised primarily of a compression glass having a thermal coefficient of expansion incompatible with that of the refractory coverings, relatively thin sections of a glass which is thermoplastic as compared with the compression glass, are disposed between the abutting surfaces of the refractory coverings and the compression glass core.

50 Thus it will be seen, that under certain circumstances, the glass sealing annulus will comprise a two-component system, a compression glass and a glass which has thermoplastic properties as compared with the compression glass.

In a preferred form of the invention, the female member includes two protective insulating sheaths: an outer sheath of elastomeric material and an inner sheath of a heat-resistant polymeric material such as polytetrafluoroethylene. The elastomeric sheath seals around the male member at low temperatures and the polymeric sheath seals around the male member at higher temperatures at which the elastomer is destroyed or rendered useless. The inner surface of the heat resistant polymeric sheath is provided with an annular groove, and the corresponding part of the male member with a mating annular ridge such that when the male and female members are connected, positive sealing is effected between the polymeric sheath and the jacket on the male member.

BRIEF DESCRIPTION OF THE DRAWINGS

The invention will be more fully explained by the following detailed description of a preferred embodiment and by the drawings wherein:

FIG. 1 is a longitudinal cross-section of a connector and a portion of an instrument housing, with several parts of the connector being shown in elevation;

FIG. 2 is a transverse cross-section of the male member along lines 2—2 of FIG. 1;

FIG. 3 is a transverse cross-section of the female member with the male member engaged therein along lines 3—3 of FIG. 1;

FIG. 4 is a transverse cross-section of the female member taken in the same plane as FIG. 3 but without the male member engaged in the female member;

FIG. 5 is an enlarged section through a portion of a male member illustrating one form of glass sealing annulus; and

FIG. 6 is an enlarged section through a portion of a male member illustrating another form of glass sealing annulus.

DESCRIPTION OF THE PREFERRED EMBODIMENTS

Referring to FIG. 1, it can be seen that the electrical connector indicated generally by the letter C comprises a male member M and a female member F. The male member comprises a central elongate pin 2 of a conductive metal such as a 52 percent nickel alloy or Kovar. The pin 2, usually of circular cross-section, has an enlarged diameter part 6. The end 8 of smaller diameter part 4 is adapted for engagement in the female member F while the end 10 of larger diameter part 6 is designed to be disposed in an instrument housing I. End 10 may be provided with male thread 92 for suitable connection to an instrument within housing I.

Part 4 of pin 2 is circumferentially surrounded by a sealing annulus 12 comprised of a material such as borosilicate glass, potash-soda-barium glass or some other such glass of high compressive strength (herein called "compression glass"). On either side of the annulus 12 are tubular coverings or sleeves 14 and 16 preferably of a ceramic formed from a suitable refractory such as aluminum oxide, zirconium oxide, a combination of aluminum and silicon oxides, a combination of aluminum and magnesium silicates, etc. Covering 14 is disposed between end 8 of pin 2 and annulus 12, and is bonded to annulus 12 at surface 18 while covering 16 is disposed between annulus 12 and the larger diameter part 6 of pin 2 and is bonded to annulus 12 at surface 20.

A metallic jacket 22 circumferentially surrounds the annulus 12 and at least those portions of the coverings 14 and 16 which are closest to annulus 12. In the particular connector shown, the jacket 22 surrounds the entire length of covering 16 and extends longitudinally beyond it toward end 10 of the pin 2. The jacket 22 is bonded to annulus 12 at surface 24 in a manner to be described below. When used in a corrosive environment, jacket 22 is preferably formed of a non-corrosive metal. For example, a 300 series stainless steel might be used. Any number of other non-corrosive metals such as stainless steel alloys and other metallic alloys may be used.

The jacket 22 has a part 26 usually of annular cross-section which is adapted for engagement in the female member F and a part 28 which is adapted for engagement in the instrument housing I. As best seen in FIG. 2, between parts 26 and 28 is an enlarged polygonal section 27 with outer surfaces 29 adapted to be gripped in screwing the male member into instrument housing I. Ceramic covering 14 has a portion 14a which extends longitudinally beyond part 26 toward end 8 of the pin 2. Portion 14a of ceramic covering 14 and part 26 of jacket 22 are of substantially uniform outer diameter with the exception of an annular ridge or dog knot 32 projecting circumferentially from part 26. The remaining portion 14b of ceramic covering 14 has an outer diameter which is substantially the same as that of the glass annulus 12 and the larger diameter part 6 of pin 2. The portion 16a of ceramic covering 16 which is closest to part 6 of pin 2 is also of substantially the same outer diameter as portion 14b of covering 14, part 6 of pin 2, and annulus 12. Portion 16b, closest to annulus 12 is of a smaller outer diameter than portion 16a. Tubular coating 30 of insulating glass surrounds portion 16a and a portion of part 6 between portion 16a and end 34 of jacket 22. The inner surface 36 of jacket 22 is configured to fit closely along the adjacent outer surfaces of the various glass and ceramic elements 14, 12, 16 and 30.

Part 28 of jacket 22 comprises a smooth portion 28a of substantially greater outer diameter than that of part 26, and another portion 28b of slightly smaller outer diameter and having a male thread 38. A resilient, O-ring gasket 40 extends circumferentially of part 28 in an annular groove 42 in portion 28a. An annular metal gasket 44 extends circumferentially of part 28 at the intersection of parts 28a and 28b. Housing I has a bore 46 threaded at 48 to engage male thread 38 and allow for connection between housing I and male member M of connector C. Bore 46 is configured such that sealing between housing I and part 28 is effected by gaskets 40 and 44.

The female member F of the connector C comprises an inner heat-resistant polymeric sheath 50. Sheath 50 should be somewhat resilient and is preferably formed by polytetrafluoroethylene or some other fluorocarbon resin. Sheath 50 has a longitudinal bore 52 therein. Within bore 52 and distal the mouth 54 of said bore is a rigid sleeve 56 which may be formed, for instance, of brass. Disposed within sleeve 56 is an electrically conductive element comprising a slotted spring 58 which may be of a beryllium-copper alloy or the like. A shoulder 84 in the interior of sheath 50 abuts sleeve 56 and spring 58. Spring 58 comprises a rigid part 58a and a lip member 58b which is biased toward part 58a (See FIG. 4) and deflectable radially outwardly, part 58a

and lip 58b being separated by a slot 60. The extension 66 of part 58a which is located between the end 62 of lip 58b and the mouth 54 of bore 52 has an annular opening 68 therethrough which is continuous with an arcuate longitudinal groove 70 in part 58a. An arcuate groove 72 in lip 58b is located opposite groove 70 in part 58a and aligned with opening 68.

An outer sheath 74 of an elastomer such as synthetic or natural rubber, polyethylene, ethylene-propylene rubber, etc. Surrounds the exterior of the inner heat-resistant sheath 50. Sheath 74 has an annular opening 76 aligned with the mouth 54 of bore 52. A conductive lead wire 78 extends through the sheaths into the element 58 and is soldered to element 58. Wire 78 has two protective insulating coatings: an inner coating 80 of polytetrafluoroethylene or some other insulating material capable of withstanding high temperatures, and an outer coating 82 of an elastomer similar to that of sheath 74. The coating 80 also extends through the two sheaths 50 and 74 up to the point where the wire 78 is soldered to spring 58.

The inner diameter of the bore 52 in sheath 50 and the aligned opening 76 in sheath 74 are sized so that part 26 of jacket 22 and portion 14a of ceramic covering 14 fit snugly therein. Inner sheath 50 is provided with an annular groove 85 positioned so as to be aligned with ridge 32 when ceramic portion 14a is abutting cylinder 56 and element 58. The resiliency of the sheaths 74 and 50 allows ridge 32 to snap into groove 85 when the male and female members are joined.

In fabricating the male member, the variations in inner and outer diameters of the various parts, described above, form shoulders which aid in assembling the parts. Refractory covering 16 may be placed on pin 2 from end 8 so that it abuts larger diameter part 6 of the pin 2. Insulating glass 3 may then be placed within part 28b of jacket 22 and this unit may be placed on the pin 2 from end 8 so that shoulder 86 abuts portion 16a of refractory covering 16 and shoulder 88 of covering 14 abuts jacket 22.

After the parts have been assembled, jacket 22 is selectively heated and then cooled so that it shrinks around the ceramic and glass parts. In a preferred method of constructing the male member M, male member M is placed in an induction furnace. Being metallic and conductive, the jacket 22 will heat at a faster rate than the insulating glass, sealing glass annulus, and ceramic coverings. Depending on the materials employed, male member M is heated to the desired temperature and then cooled to a lower temperature over a relatively short period of time. The jacket is kept at the lower temperature for a period of time sufficient to allow annealing of the glass in annulus 12 and then further cooled to ambient temperature. The temperatures and times of heating and cooling will vary depending on the materials used. The cooling is preferably done in an atmosphere of argon, nitrogen or some other inert gas to prevent oxidation of the metal portion of the connector. The cooling and simultaneous shrinking of the jacket causes the various elements to fit so tightly together that jacket 22 is in effect bonded or fused to the ceramic coverings. The shrinking also fuses or bonds layer 30 of insulating glass to pin 2 and jacket 22 so that pin 2 is prevented from rotating by torque when a connection is made to thread 92.

The heating, followed by the cooling and shrinking, bonds the glass annulus 12 to the pin 2, jacket 22 and

ceramic coverings 14 and 16 along respective surfaces 90, 24, 18 and 20. The bonds between the various components are believed to be chemical bonds as well as physical seals, the latter being due to the tight engagement caused by shrinking, or a combination of the two.

The maintenance of the fluid tight seals formed at surfaces 90, 24, 18, and 20 may be insured in several ways. In one form of the invention the glass annulus 12 has a thermal coefficient of expansion compatible with that of the jacket 22. Thus the two expand and contract in a complementary manner such that the annulus 12 is never cracked by expansion of either member yet the two remain pressed together sufficiently tightly to form effective seals along the surfaces of the annulus 12. Metals whose thermal coefficients of expansion are compatible with compression glasses are often of the non-corrosive type, e.g., stainless steel and stainless steel alloys, whereas metals compatible with refractories are usually corrosive or otherwise unsuitable for underground use because of weak physical properties, unavailability or magnetic susceptibility. It should be understood that the term "compatible" as applied to the thermal coefficients of expansion of the various materials does not necessarily mean identical thermal coefficients of expansion but rather coefficients so related that the various parts expand and contract when subjected to varying temperatures at a rate which ensures the integrity of the connector will be maintained.

In FIG. 5 is shown a form of the invention wherein the metal jacket has a thermal coefficient of expansion incompatible with the compressible glass generally employed in forming annulus 12. In the embodiment in FIG. 5, annulus 12 comprises a core 12a of borosilicate glass, potash-soda-barium glass or some other such compression glass and a relatively thin outer peripheral coating 12c disposed between core 12a and jacket 22 of a glass having thermoplastic properties relative to core 12a. For example, a suitable glass to be used as outer covering 12c is a glass such as silicate glass, borate glass, borosilicate glass, etc. containing relatively large amounts of lead oxide or an oxide of some other heavy metal. A typical high lead silicate glass usable as the thermoplastic coating has a composition comprising (by weight) approximately 72 percent PbO, 14% B₂O₃ and 14% SO₂. Other glasses having thermoplastic properties relative to the compression glass used may also be employed.

In FIG. 6 is shown still a further embodiment wherein the ceramic covering 14 and 16 have thermal coefficients of expansion incompatible with core 12a of annulus 12. In the embodiment of FIG. 6, annulus 12 comprises a central annular core 12a of a compression glass such as those mentioned above and annular end sections 12b and 12d of a glass having thermoplastic properties relative to the core 12a. As noted above for the embodiment of FIG. 5, the relatively thin thermoplastic layers 12b and 12d can be comprised of a high lead silicate glass or some other such material. It should be understood that layers 12b, 12c and 12d are in practice quite thin, even monomolecular in thickness, although they have been shown as much thicker layers for purposes of illustration.

In the embodiments of FIGS. 5 and 6, the glass sealing annulus is comprised of two components, i.e., a compression glass and a glass having thermoplastic properties as compared with the compression glass. In such cases the compression glass is bonded to the ther-

moplastic glass which in turn is bonded to the jacket or to the refractory sections or to all three if the compression glass core is encapsulated in a thermoplastic glass covering.

Other modifications of the connector disclosed herein might include the provision in the annulus 12 of a layer of thermoplastic glass material (not shown) disposed to lie adjacent the pin 2.

It will thus be appreciated that connectors according to the invention provide a plurality of means for preventing leakage from the high pressure area H outside the connector to the low pressure area L in the instrument housing I as well as other advantages. At low pressures, the outer sheath 74 of the female member seals against part 26 of jacket 22 to prevent leakage between the male and female members. At high temperatures, above 400°F., the outer sheath 74 deteriorates and does not act as an effective seal. At the higher temperatures and pressures the inner sheath 74 complements the inner sheath 50 which often cannot act as an effective seal at low pressures. The sealing properties of the polymeric inner sheath 50 are enhanced by the groove 85 and mating ridge 32. The brass sleeve 56 prevents extrusion of material from the sheaths 50 and 74 into the slit 60 which is a problem at any pressure. Similarly, gasket 40 prevents leakage between the housing I and part 28 at low temperatures while gasket 44 prevents such leakage at high temperatures and pressures.

If for any reason fluid should leak between the male and female members, it is inhibited from further leakage between the elements of the male member and into the housing by the tightness with which the elements of the male member are fused together. The glass annulus 12, being comprised of a glass of high compressive strength, helps to protect the ceramic insulating coverings 14 and 16 from being crushed by expansion of the jacket 22. If ceramic covering 14 should crack, or if for any other reason leakage should occur through the male member from the lead end in the female member, this leakage will be stopped by the seals formed at annulus 12 and will not proceed into the instrument housing. The use of the relatively small annulus 12 thus allows the use of preferred ceramic coverings as insulators throughout the major portion of the male member in a fused combination in which the thermal coefficient of expansion of the ceramic covering is not necessarily compatible with that of the metal jacket. As noted above, the pin 2 may be made of a nickel alloy or other metal compatible with ceramic in order to further enhance the salient characteristics of the connector.

The invention having been thus described, what is claimed is:

1. An electrical connector comprising a male member, and a female member, said male and female members being releasably connectable to one another, said male member comprising a conductive pin having a first end and a second end, a glass sealing annulus circumferentially surrounding a portion of said pin intermediate the ends of said pin, a first refractory covering adjacent said annulus and circumferentially surrounding a portion of said pin between said first end and said annulus, a second refractory covering adjacent said annulus and circumferentially surrounding a portion of said pin between the annulus and said second end of said pin, and a metallic jacket circumferentially surrounding said annulus and portions of said refractory coverings directly adjacent said annulus, said annulus

being bonded to said jacket, to said pin and to said refractory coverings.

2. An electrical connector according to claim 1 wherein said annulus is comprised of a compression glass.

3. An electrical connector according to claim 1 wherein said annulus has a thermal coefficient of expansion compatible with the thermal coefficient of expansion of said jacket.

4. An electrical connector according to claim 1 wherein said annulus comprises an inner core of a compression glass and a relatively thin layer of a glass having thermoplastic properties compared to said core, said layer being disposed between said core and said jacket.

5. An electrical connector according to claim 1 wherein said annulus comprises a central core of a compression glass and opposing end sections of a glass having thermoplastic properties compared to said core, each of said end sections being thin relative to said core and being disposed between said core and one of said refractory coverings.

6. An electrical connector according to claim 1 wherein said jacket has a portion extending longitudinally beyond said second refractory covering toward said second end of said pin and wherein a tubular insulating member is disposed between said pin and said extending portion of said jacket.

7. An electrical connector according to claim 6 wherein said male member further comprises gasket means disposed circumferentially of said extending portion of said jacket for sealing between said extending portion and an instrument.

8. An electrical connector according to claim 1 wherein said female member comprises a resilient, heat-resistant polymeric inner sheath having a bore for receiving said male member, an elastomeric outer sheath surrounding said inner sheath and having an annular opening aligned with the mouth of said bore, a conductive element extending through said sheaths, means disposed in said inner sheath for releasably engaging said first end of said pin and means providing electrical contact between said pin and said conductive element.

9. An electrical connector according to claim 8 wherein said jacket has a part snugly receivable in said bore and said opening in said outer sheath and has an annular ridge extending circumferentially thereabout and said inner sheath has an internal annular groove in said bore whereby said ridge snaps into said groove when said male and female members are connected.

10. An electrical connector according to claim 8 wherein said female member further includes a rigid sleeve disposed in said bore, and said means for releasably engaging said pin and said means providing electrical contact comprises a conductive spring in contact with said conductive element.

11. An electrical connector according to claim 7 wherein said inner sheath is comprised of a fluorocarbon resin.

12. An electrical connector according to claim 7 wherein said conductive element comprises a wire and an inner, insulating heat-resistant polymeric coating is disposed around said wire and an outer protective elastomeric coating is disposed around said inner coating.

13. An electrical connector according to claim 1 wherein said pin has a thermal coefficient of expansion compatible with the thermal coefficient of expansion of said refractory coverings.

* * * * *