

[54] **COMPUTER ASSISTED RADIATION THERAPY MACHINE**

[75] Inventor: **John M. Pavkovich**, Palo Alto, Calif.

[73] Assignee: **Varian Associates**, Palo Alto, Calif.

[22] Filed: **Nov. 27, 1970**

[21] Appl. No.: **93,331**

[52] U.S. Cl. **235/151, 250/61.5, 444/1**

[51] Int. Cl. **A61n 5/01**

[58] Field of Search **235/151, 61.6 H, 235/151.3; 250/61.5**

[56] **References Cited**

UNITED STATES PATENTS

3,591,806	7/1971	Brill et al.	250/61.5 X
2,943,205	6/1960	Kazan et al.	250/95 UX
3,100,843	8/1963	Foster	250/95 X

FOREIGN PATENTS OR APPLICATIONS

831,597	1/1970	Canada	235/151
---------	--------	--------------	---------

Primary Examiner—Eugene G. Botz
Attorney—Stanley Z. Cole and Leon F. Herbert

[57] **ABSTRACT**

A computer assisted radiation therapy machine is disclosed. The machine includes a rotatable gantry having a radiation source portion which is rotatable about a patient treatment couch. Geometric and dose parameters of the machine for defining a prescribed treatment plan of radiation are stored in the memory of the computer. A readout and display means is provided for displaying the geometric and dose parameters of the defined radiation treatment plan. Editing and updating capability are provided for editing and updating the treatment plan with the cumulative radiation dose administered to each portal and the total cumulative dose administered to the patient. Each parameter of a proposed treatment plan is compared with permissible ranges of machine parameters stored in a memory to verify that the proposed treatment is within the permissible range of the machine.

9 Claims, 4 Drawing Figures

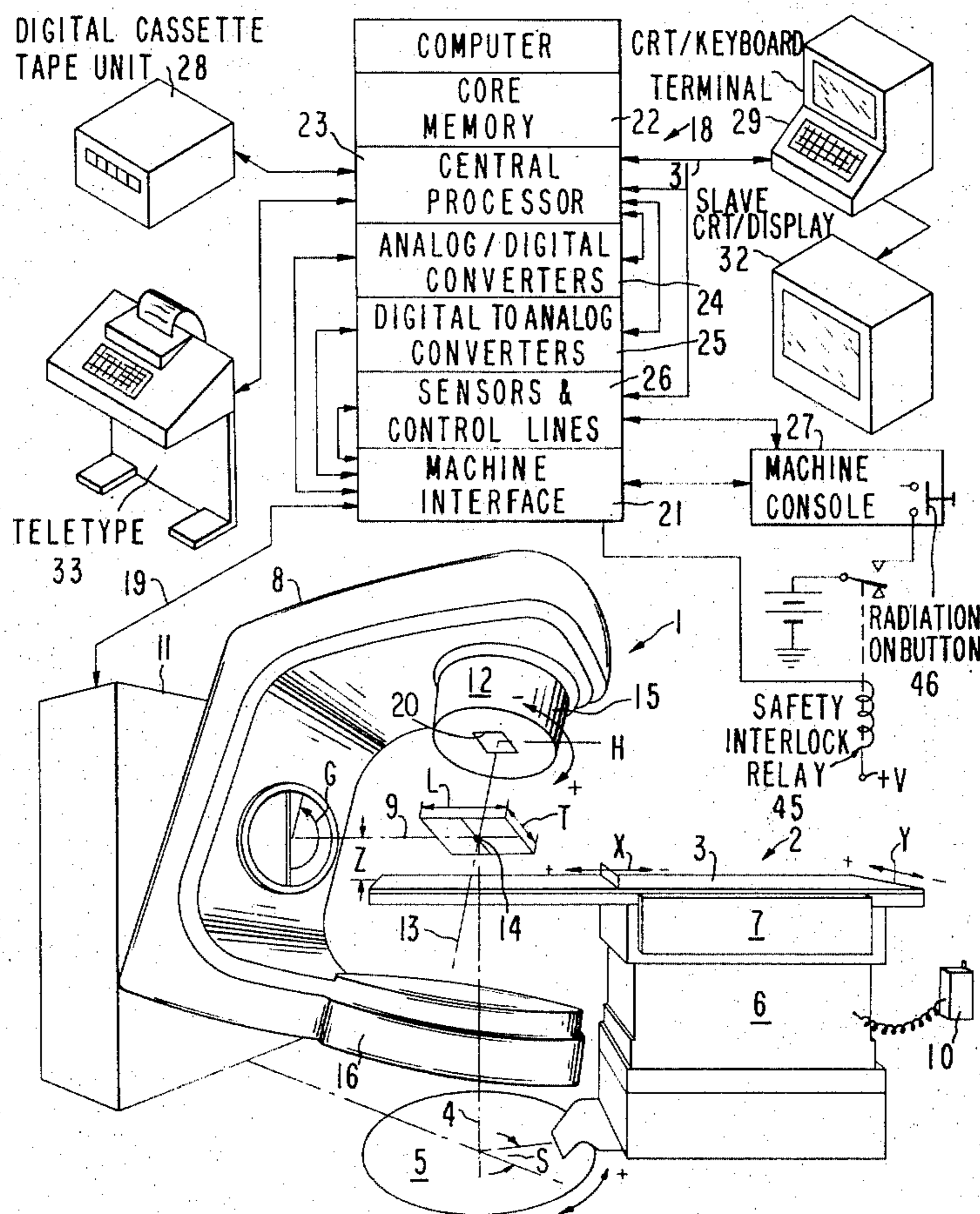

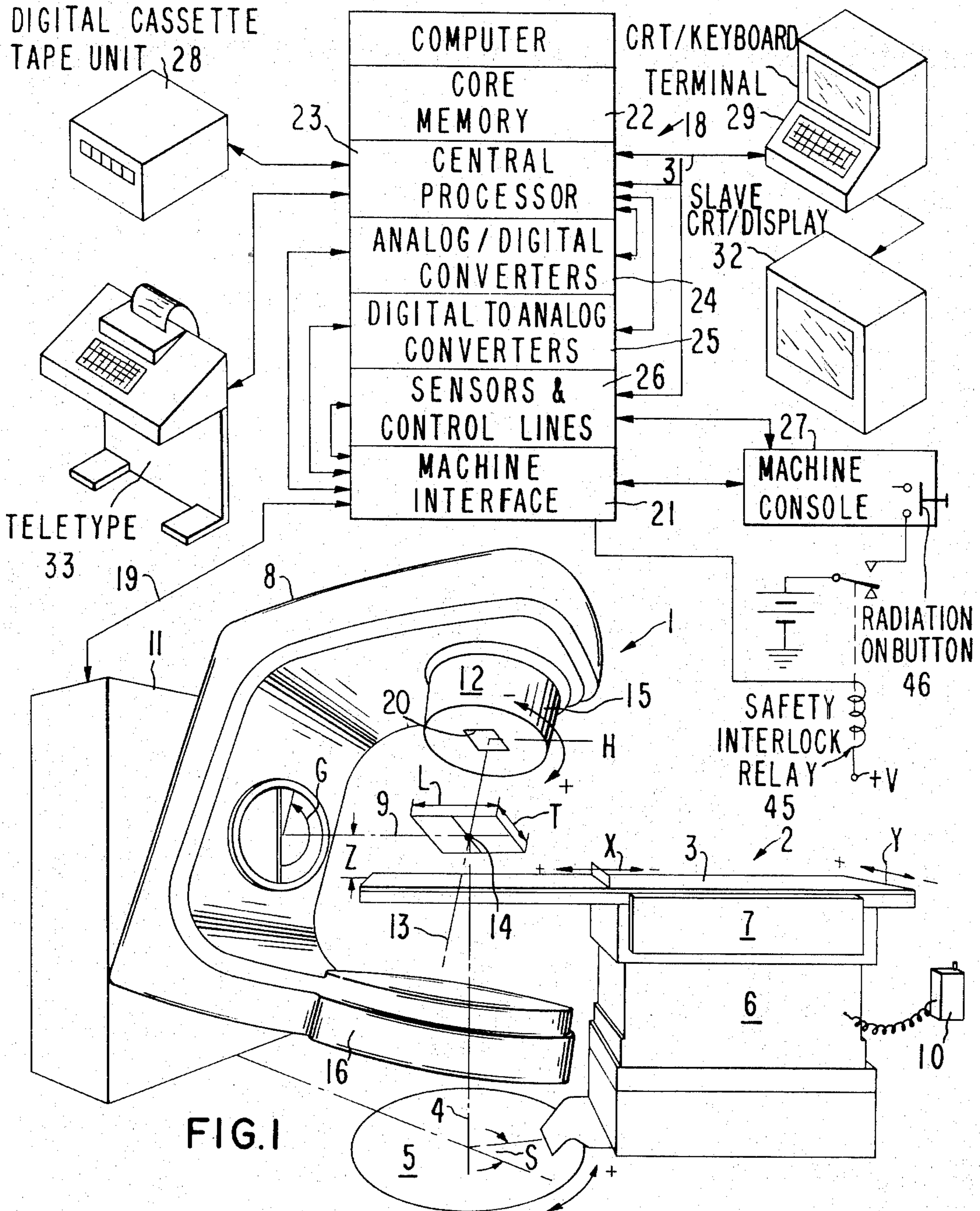

FIG. 1

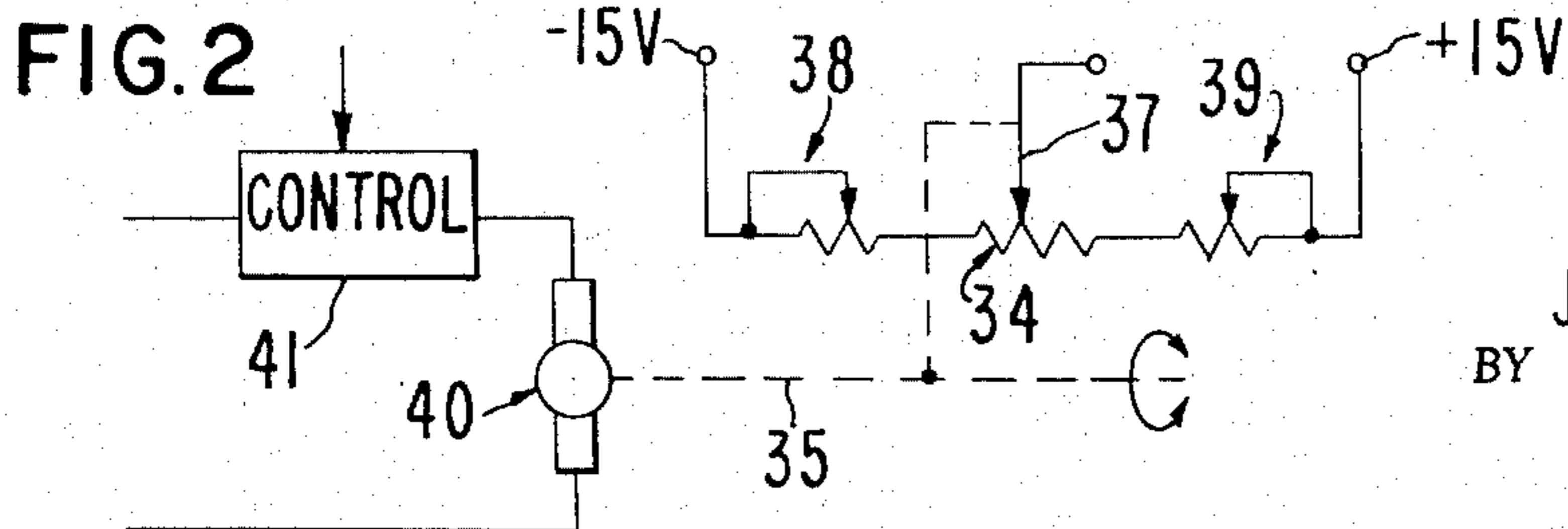

FIG. 2

INVENTOR.
 JOHN M. PAVKOVICH
 BY
 Leon F. Herbert
 ATTORNEY

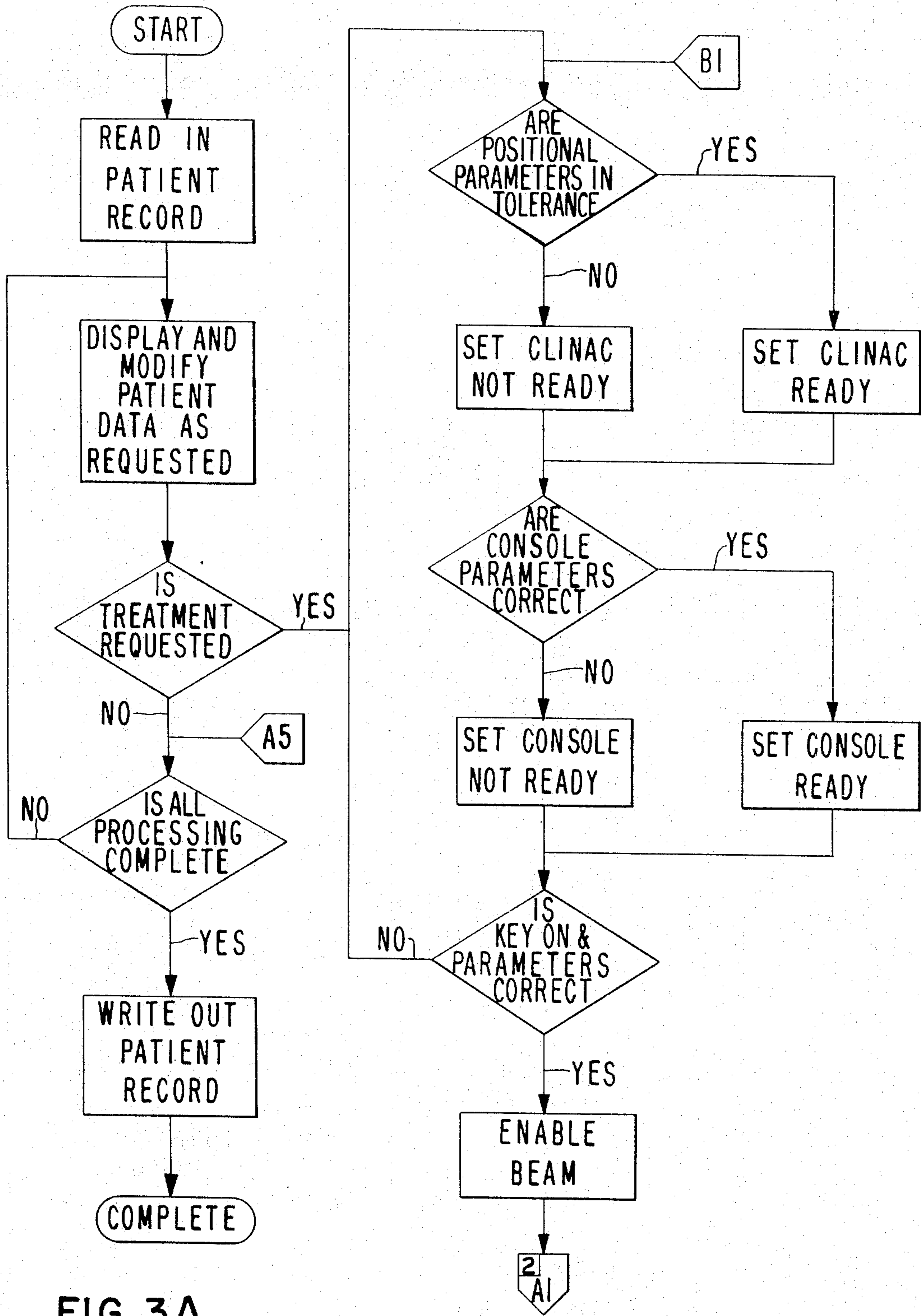

FIG. 3A

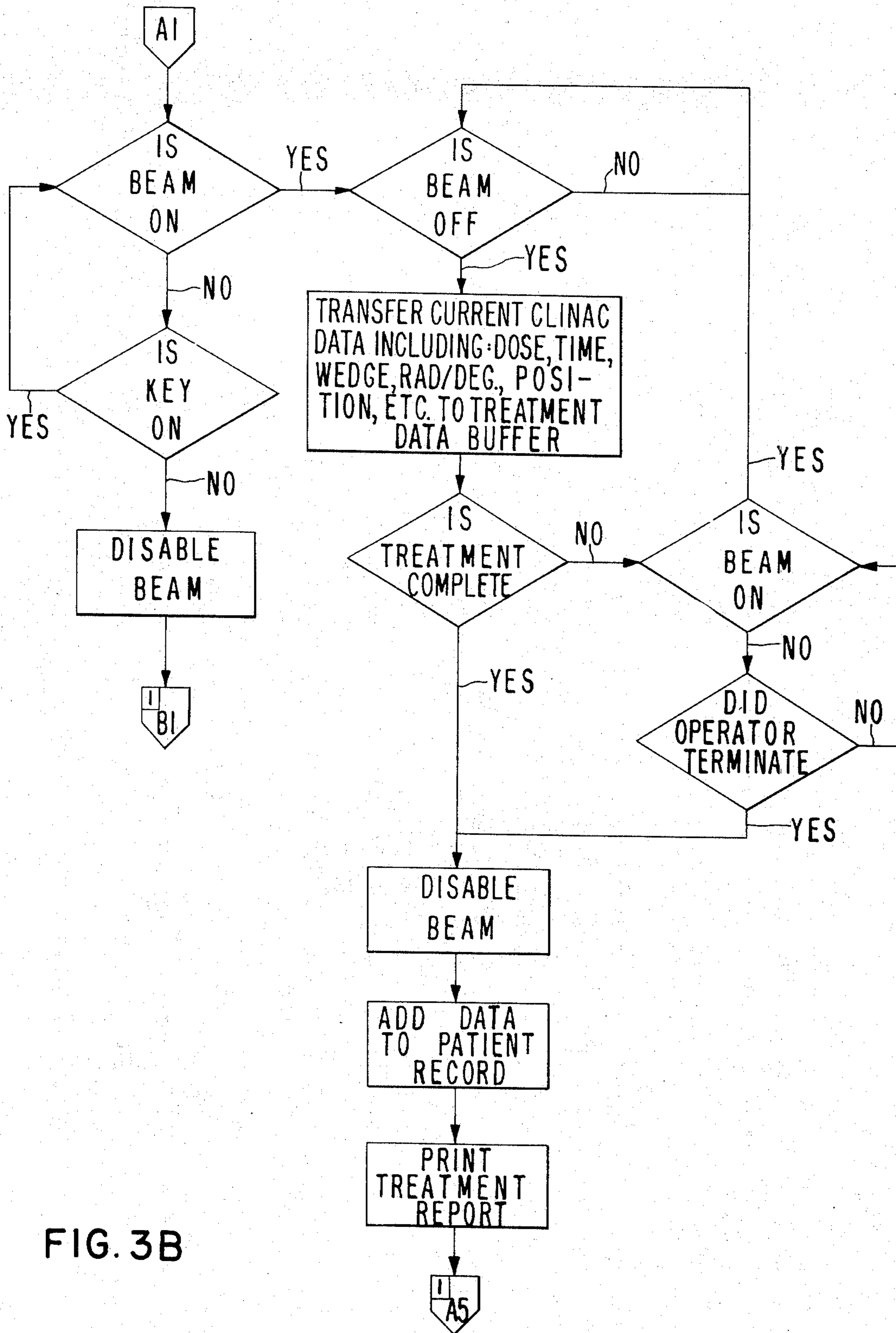

FIG. 3B

COMPUTER ASSISTED RADIATION THERAPY MACHINE

DESCRIPTION OF THE PRIOR ART

Heretofore, the mechanical setup of a radiation therapy machine has been automated for decreasing the setup time and improving the accuracy of the mechanical setup for a radiation therapy treatment. In the prior machine, the desired positional information for the mechanical setup of the machine was punched into cards according to a prescribed plan of treatment. A deck of cards representing the setup for the prescribed plan of treatment was fed into a card reader. The output of the card reader was fed to control circuits for sequentially controlling the mechanical motion of the various movable parts of the machine for geometrically positioning the machine according to the prescribed plan of treatment. A four digit visual display was provided for displaying the position of each of the mechanically movable elements of the radiation therapy machine.

While the aforementioned automated radiation therapy machine substantially decreased the setup time and improved the accuracy of the setup, it did not include means for automatically maintaining an updated reading of cumulative radiation dose delivered to a patient through a prescribed radiation portal nor did it automatically maintain a cumulative total of radiation administered to a given patient.

The prescribed treatment plan for a patient, in the prior machine, could be edited and updated by punching a new set of punched cards. However, mistakes could be made by the keypunch operator and these mistakes would be incorporated into the treatment plan to be administered to the patient.

It is desired to obtain an improved automated radiation therapy machine which automatically verifies a proposed plan of treatment against a range of permissible values to prevent setting up or editing a treatment plan which is not in conformance with a predetermined range of permissible values for each parameter of a treatment plan.

SUMMARY OF THE PRESENT INVENTION

The principal object of the present invention is the provision of an improved automated radiation therapy machine.

One feature of the present invention is the provision of means for automatically editing and updating a patient's treatment plan with the cumulative total of radiation dose, if any, administered to the certain patient.

Another feature of the present invention is the same as the preceding feature wherein the means for automatically editing and updating the patient's treatment plan includes a programmed general purpose computer.

In another feature of the present invention, cathode ray tube keyboard terminal or a teletype terminal is interactively coupled to a general purpose computer for editing, reading out, and displaying the updated treatment plan.

In another feature of the present invention, information defining a radiation treatment plan for a given patient is stored in a first memory means, such as a magnetic tape cassette paper tape or magnetic disc. This information is transferred into the memory of the computer and the computer reads the stored information, upon command, to a readout and display terminal hav-

ing the capability for updating the treatment plan information stored in the computer.

In another feature of the present invention, information is stored defining permissible ranges of values for a treatment plan of machine parameters and the corresponding parameters of a proposed treatment plan are compared against the stored range of permissible values to derive an interlock output if the value of a proposed machine parameter is outside the range of permissible values to derive an interlock output if the value of a proposed machine parameter is outside the range of permissible values. The interlock output is employed to prevent transfer of the proposed treatment parameter into the treatment plan for the patient.

BRIEF DESCRIPTION OF THE DRAWINGS

FIG. 1 is a schematic diagram, partly in block diagram form, of an automated radiation therapy machine incorporating features of the present invention,

FIG. 2 is a schematic circuit diagram for deriving signals determinative of the settings of the respective variable parameters of the radiation therapy machine, and

FIGS. 3A and 3B shows computer program flow chart for the computer assisted radiation therapy machine of FIG. 1.

DESCRIPTION OF THE PREFERRED EMBODIMENTS

Referring now to FIG. 1, there is shown a computer controlled radiation therapy machine incorporating features of the present invention. The radiation machine 1, such as a CLINAC[®] radiation therapy machine model 4 or 35, commercially available from Varian Associates, or a THERATRON 80 automated cobalt 60 radiation machine made by Atomic Energy of Canada Limited of Ottawa, Canada, includes a couch 2 having a table portion 3 which receives the patient to be treated. The couch 2 is rotatable about a vertical axis 4 by means of a turntable 5 which the couch 2 is affixed. The couch includes an elevator portion 6 for translating the couch in the vertical direction Z. In addition, the couch includes motorized drives for translating the table 3 in the lateral Y direction and longitudinal X direction. A control pendant 10 is connected to the couch 2 via suitable cable for manual control of the various portions of the radiation machine 1 and for allowing automatic control of the radiation machine 1 by the computer.

A generally C-shaped gantry 8 is rotatable by 359° about a horizontal axis 9. The gantry 8 is rotatably supported from a stand 11. A source of radiation, such as a linear accelerator producing a high energy electron beam which is directed against an X-ray target, produces a beam of X-rays emanating from a collimator head portion 12. As an alternative, in the case of the cobalt machine, the cobalt serves as a source of X-ray radiation, and is housed within the collimator head portion 12. The X-rays are directed out of the radiating head portion 12 in a beam having an axis 13 which intersects the gantry axis of rotation 9 at a position identified as the isocenter 14, which is also intersected by the turntable axis 4.

The head portion 12 includes two sets of movable beam defining jaws, as of lead, which are movable to define the length L and thickness T of the field of the X-ray beam as collimated by the beam defining jaws. The source 12 is enclosed in a barrel shaped collimator

housing 15. The source housing 15, along with beam defining jaws, are rotatable about the beam axis 13. The gantry 8 includes a beam stopping portion 16 disposed along the X-ray beam axis 13 and holding an X-ray absorbing material, such as lead, for stopping and absorbing the X-ray beam.

A digital computer 18, such as a Varian Data Machine Model 620/i general purpose digital computer, is coupled to the radiation therapy machine 1 via the intermediary of a control cable 19 and an interface 21. The computer 18 includes a core memory portion 22 interconnected to a central processor 23 which includes the address and arithmetic units. Sixteen channels of analog-to-digital converters 24 are provided for converting analog output signals derived from the radiation therapy machine 1 to digital form which are in turn fed into the central processor 23 for use therein and for use in the memory 22. Eight channels of digital-to-analog converters 25 are provided for converting digital output signals from the central processor 23 into analog signals which in turn are fed into the radiation therapy machine 1 via the intermediary of the interface 21. Sensor and control lines 26 are provided for sensing and controlling functions of the radiation therapy machine via the interface 21. A machine console 27 is coupled to the radiation therapy machine 1 and to the computer 18 via the machine interface 21.

The Varian data machines 620/i computer 18 is a system oriented digital computer. It has a total memory capacity of 12,388 words of 16 or 18 bits and is plug-in expandable. The memory is magnetic core with 1.8 microseconds full cycle and 700 nanoseconds access time. The arithmetic is parallel, binary, fixed points, 2's complement. It has seven addressing modes and over one hundred standard instructions. In addition, to the standard equipment which comes with the Varian 620/i computer, the computer 18 includes, a 620/i expansion chassis, two 620/i memory modules providing an extra 8,192 words, a 620/i-17 optional package, a 620/i-51 paper tape reader, an acquisition and control unit, and the 620/i machine interface 21.

The 620/i-17 optional package contains hardware multiply/divide, extended addressing, real time clock, power fail/restart, and eight level priority interrupts. The 620/i-51 accessory is a high speed paper tape reader which provides for rapid means to load the memory should a program be lost or scrambled for some reason. It is an input device only and will not punch. It reads at 300 characters per second. The acquisition and control unit contains the following: 7 or 12 bits plus sign programmable sample-and-hold, 16 channels or multiplexed analog-to-digital conversion 24, and the eight channels of 9 bit plus sign digital-to-analog converters 25 plus 16 sense and eight control lines 26. In addition, the acquisition and control unit contains the BCD registers and controller for the BCD information available from the radiation machine 1.

A digital cassette tape unit 28, such as a model 100 COMPUCORDER available from Datatronics, Inc. of Rochester, New York, is coupled by suitable cables to the central processor 23 for reading digital data, stored in the patient's individual cassette, into the central processor 23 and memory 22. In addition, outputs from the processor 23 are recorded back into the patient's cassette via the tape unit 28. A cathode ray tube/keyboard terminal 29, such as a model ALPHA 103A CRT/keyboard terminal, commercially available from Beehive

Medical Electronics, Inc. of Salt Lake City, is coupled to the central processor 23 via cable 31 for displaying data read from the memory 22 through the central processor 23 and for controlling certain operations of the radiation therapy machine 1 via the computer 18.

The CRT terminal 29 forms the major input-output device for the computer 18 and includes an alpha numeric display. It has a standard typewriter keyboard and four way cursor control. In addition, it has an 11 inch CRT screen with 20 lines and 40 characters per line. The CRT terminal 29 has type-over capability using the cursor as well as line-erase and screen-clear. It has its own internal character generator with 64 characters ASC II set. A remote slave cathode ray tube (CRT) 32 is provided for remote data observation. A standard ASR 33 teletype unit is coupled to the central processor 23 via suitable cables to provide a hard copy printout and to serve as a backup input for the CRT/keyboard terminal 29 and for the paper tape reader accessory of the computer 18.

Referring now to FIG. 2 there is shown one of the circuits for generating an analog positional signal determinative of the position of one of the variable parameters of the radiation machine 1, such as: gantry angle G; housing angle, H; couch position in the X, Y and Z directions, etc. The positional signal circuit of FIG. 2 includes a potentiometer 34, as of 10 k ohms, attached to the drive shaft 35 via mechanical coupling 36. Drive shaft 34 generates the motion of the parameter being controlled, such that a full-scale motion of the parameter being varied or controlled results in generating a full scale +10 volts to -10 volts analog output derived from the pickoff 37 of the potentiometer 34. -15 volts and +15 volts, respectively, are applied to opposite ends of the potentiometer 34 through trimming potentiometers 38 and 39 provided at the ends of the potentiometer 34. The trimming potentiometers 38 and 39 provide for calibration of the range and the end points for each positional output readout. One turn 0.25 percent linearity, 0.095 percent resolution potentiometers 34 are utilized on the beam collimator jaws, and position indicators. Ten turn 0.1 percent linearity, 0.019 percent resolution potentiometers 34 are provided for each of the other analog positional readouts.

Each of the motorized control motions of the radiation machine 1 is driven by a shunt-wound dc motor 40 operated by an SCR controller 41. With exception of the gantry rotation controller, each controller is open-loop providing full output in response to a 6-volt dc signal, decreasing to 0 output at 0.5 volts dc (± 0.5 dead band volts). The gantry speed control is closed loop, speed regulated, full speed output in response to a 12-volt dc input, against with ± 0.5 dead band volts. The turntable drive is equipped with a brake which is engaged when the input voltage of the motor controller is zero. The couch longitudinal and lateral motions have switch actuated electric clutches engaging their respective drives.

Control of each motion of the radiation therapy machine 1 is obtained by direct digital control. Positions of each of the eight analog motions are sampled, by sampling the output of each potentiometer 34, every 50 milliseconds, 10 microseconds required for each sample. Sampling is controlled by the central processor 23 and is effected through the interface 21 to the positional control circuits of FIG. 2 coupled to the drive 35 for each of the driven elements of the radiation therapy

machine 1. The driven motions are sufficiently fast so as to alter their feedback from zero to full scale in 15 seconds. Assuming a 12-bit plus sign analog-to-digital converter output will vary a maximum of one least-significant bit in 3.6 milliseconds, allowing observation of at most four least-significant bit changes at every reading.

Each patient has in his file a digital tape cassette. For treatment of a patient, his cassette is loaded into the tape unit 28 and a command from the keyboard terminal 29 causes the tape to be read into the central processor 23 and stored in the memory 22 of the computer 18. The information transferred from the cassette to the memory 22 of the computer 18 includes the patient's identification number, his name, the diagnosis of his condition, the portal definition of eight separate radiation treatment portals, each including an identification number 1-8 and a definition of the quantities, G, S, X, Y, Z, H, L, T, and dose for each of the defined portals, whether the individual treatment will involve arc therapy, and if so the start and stop gantry angles G, and the rads per degree, and information as to which, if any wedge is to be employed and whether blocks are to be employed. Wedges serve to shape the intensity of the radiation beam, and blocks serve to protect certain portions of the patient being treated for radiation emanating from the beam. In addition, information stored in the memory 22 from the patient's cassette, includes a sequence of how the portal definitions are to be administered, i.e., the treatment plan, the monitored cumulative dose per portal, and the total cumulative dose for the patient.

Once this information has been stored in the computer 18, the keyboard terminal 29 is actuated for displaying desired information from the memory 22 on the display of the keyboard terminal 29. On a proper command from the keyboard terminal 29, the central processor 23 causes to be displayed, from the memory 22, on the cathode ray tube display 29, the next treatment to be given. For example, a certain radiation portal is defined on the visual alphanumeric CRT display, with the prescribed set points for the quantities of G, S, X, Y, Z, H, L, T, etc. Opposite the prescribed values for the aforementioned quantities, which define the treatment to be given, is displayed the corresponding present position of each of the settings of the radiation therapy machine 1. Positional values are obtained from the output of the positional circuits of the type shown in FIG. 2 as converted to digital form via the analog-to-digital converters 24 and as sent to the display tube of the keyboard terminal 29, from the central processor 23. Upon depressing the proper command button on the machine control pendant 10, the central processor 23 causes the actual positional signal to be monitored and to be compared with the prescribed positional signal to derive error signals which are fed to the controllers for causing the radiation therapy machine 1 to take the positions defined by the treatment plan being executed.

An anti-collision program is stored in the memory 22 and the central processor, in conformance with the program, continually checks for the possibility of a collision between the gantry 8 and the couch 2. If imminent collision is determined, an anti-collision subroutine is executed to avert the collision. The radiation machine is positioned in accordance with the predetermined prescribed plan. The geometric set points can be

achieved in less than 30 seconds because all of the geometric motions of the radiation machine are obtained simultaneously.

As each of the geometric parameters achieves its set point, the set point value is displayed on the cathode ray tube opposite the corresponding prescribed value for the treatment plan being executed. Thus, all the set point values for the quantities G, S, X, Y, Z, H, L and T are achieved automatically and presented automatically. The planned values for dose, time, rads per degree, stop angle, wedge and blocks are displayed but these adjustments are made manually from the machine console 27. Each of the manual adjustments from the machine console 27 has a BCD positional output signal generator of conventional design coupled thereto in the conventional manner. As the manually adjustable parameters are set, the corresponding positional value is fed into the computer 18 and presented on the display adjacent the planned value. Each wedge and block is separately coded with electrical connections and electrical connections are made to these coded connections for feeding an input signal to the computer 18 corresponding to the particular wedge or block employed. Thus wedge and block information is also fed to the computer and presented on the display 29.

The computer 18 is programmed to compare the prescribed value for all of the aforementioned geometric and other machine parameters against the set point values achieved for each of the adjustable parameters. If all of the prescribed values do not conform to the set point values, the computer 18 generates an interlock output signal which is fed via the machine interface 21 to actuate a relay 45 which opens a circuit in the machine console 27 and prevents energization of the radiation "ON" button 46 in the machine console 27 such that the beam of radiation cannot be turned onto the patient until all of the actual set points values for the variable parameters of the radiation machine conform to the prescribed values. This greatly reduces the probability of the operator making a mistake and delivering a dose of radiation to the patient which is not called for by the prescribed treatment plan. Tolerances in the mechanical settings can be built into the system to compensate for uncertainties in patient positioning on the treatment couch 2.

The radiation head portion 12 of the radiation therapy machine 1 includes a dosimeter 20 for monitoring the dose of radiation actually administered to the patient. The output from the dosimeter is continually monitored by the computer 18 throughout the treatment. The measured radiation dose per treatment is stored in the memory 22 of the computer and displayed on the CRT/terminal display 29. In addition, the computer updates the patient treatment plan status information stored in the memory 22 by updating the portal status portion of the treatment plan to include the cumulative total of radiation dose administered through the particular portal just administered and the total dose administered to the patient. The status information is also updated to include which treatments in the sequence of treatments has been administered and which numbered treatment is to be administered next.

The treatment plan portion of the patient's treatment plan information stored in the memory 22 is also updated by the computer by entering a mark such as an asterisk under the number of the portal definition just

administered in the sequence of portal numbers which defines the treatment plan sequence.

After the treatment is terminated an interlock signal goes to the computer 18 from the radiation machine 1. This interlock signal prevents the computer from performing any functions other than printing out the updated portal definition information for the portal just administered. The print out is on the teletype 33. The print out includes the complete portal definition of prescribed and present positions of the elements, etc., together with present date, time, cumulative dose for this portal and the grand total of dose administered to the patient.

After the print out, the operator types the command END at the keyboard terminal which commands the computer 18 to readout all the updated treatment plan information, portal definition information, etc., relating to this patient from the memory 22 back into the individual patient's tape cassette via the tape deck unit 28.

Any detail of the prescribed overall radiation treatment plan or any one of the prescribed parameters of an individual portal descriptions can be easily changed during the course of treatments. The operator pushes an EDIT button on the CRT keyboard terminal 29 and types in the appropriate change at the keyboard. Two levels of edit capability are incorporated. Certain major changes, such as overall treatment plan, can only be initiated by supervisory personnel with a special access key which serves to complete an interlock circuit in an interface between the CRT/keyboard terminal 29 and the central processor 23. If the therapist desires periodic examination before certain treatments can be administered to the patient, he can require that some one of supervisory rank be present at a given treatment by typing in an appropriate legend in the overall treatment plan.

Any proposed new machine parameter for a change in a treatment plan or portal definition is compared by the computer 18 against the respective permissible ranges for that parameter stored in the memory 22. If the proposed value of the parameter is within the permissible range the change is entered and the treatment plan or portal definition stored in the memory 22 is thus edited.

If the proposed change in parameter is not within the permissible range of values, an error message is displayed on the CRT display 29 and the proposed parameter change is not entered.

The computer assisted radiation machine 1 also includes a simulator mode of operation. In the simulator mode the radiation therapy machine is manually controlled by the operator from the pendant 10 to position the geometric machine parameters for a certain treatment to be administered. The final settings of the machine are monitored by the respective positional output signals and define portions of a complete portal definition. Upon a command the operator causes the computer 18 to transfer the manually set machine parameters into the memory 22 to establish a portal definition in a treatment plan of information stored for that patient in the memory 22. Subsequently this portal definition is completed by the operator and becomes a part of the patient treatment plan to be transferred to his cassette in the manner as previously described above. A computer program flow chart the aforescribed computer program is shown in FIG. 3.

Since many changes could be made in the above construction and many apparently widely different embodiments of this invention could be made without departing from the scope thereof, it is intended that all matter contained in the above description or shown in the accompanying drawings shall be interpreted as illustrative and not in a limiting sense.

RELATED CASES

The simultaneous motion and anti-collision program are described and claimed in copending U.S. application Ser. No. 93,327 filed Nov. 27, 1970, now U.S. Pat. No. 3,720,817. The feature of verifying the prescribed treatment plan against the actual settings of the radiation machine is disclosed and claimed in copending U.S. application Ser. No. 93,332 filed Nov. 27, 1970, both applications are assigned to the same assignee as the present invention.

What is claimed is:

1. In a radiation therapy apparatus, couch means for supporting a patient to receive radiation, radiation source means for applying radiation to the patient, means for supporting and moving said radiation source means around said couch means, means for storing information defining geometric and radiation dose parameters of the radiation machine for defining a prescribed radiation treatment to be administered to the patient, means for reading out of said storage means and displaying to an operator the geometric and dose parameters defining the prescribed plan of radiation treatment, means for deriving an output representative of the dose of radiation actually administered to the patient from said source means in carrying out the defined plan of treatment, means for automatically editing and updating said storage means with the derived dose output by adding the derived dose output to the cumulative total of previously derived dose outputs, if any, administered to the patient and stored in said storage means, to obtain an updated cumulative total radiation dose output in said storage means.

2. The apparatus of claim 1 wherein said means for displaying and reading out of said storage means the parameters of a prescribed plan of treatment includes, means for reading out the edited and updated cumulative total radiation dose output from said edited and updated storage means.

3. The apparatus of claim 1 wherein said storage means and said editing and updating means includes, a programmed general purpose computer.

4. The apparatus of claim 3 wherein said readout and display means includes, cathode ray tube terminal means interactively coupled to said general purpose computer means.

5. The apparatus of claim 3 wherein said readout and display means includes, teletype terminal means interactively coupled to said programmed general purpose computer means for printing out the edited and updated treatment plan parameter stored in said storage means.

6. The apparatus of claim 1 wherein said means for deriving an output representative of the dose of radiation actually administered to the patient includes, dosimeter means disposed in the beam of radiation administered to the patient.

7. The apparatus of claim 1 including, programmed general purpose computer means having a memory portion, and wherein said storage means for storing the

geometric and dose parameter information defining a prescribed radiation treatment plan includes said memory of said computer means, and including second information storage means for storing geometric and dose parameter information defining a prescribed radiation treatment plan for a given patient, means for reading the treatment plan information stored in said second storage means into said memory portion of said computer means, means for recording information in said second information storage means, and said computer means being programmed to read the edited and updated treatment plan information from said memory portion of said computer to said recording means for recording the updated treatment plan information in said second information storage means.

8. The apparatus of claim 7 wherein said second storage means includes, an information storage tape me-

dium.

9. The apparatus of claim 1 wherein, said storage means also includes means for storing information defining permissible ranges of values of treatment plan parameters for radiation treatment plans to be administered to the patient, means for comparing a proposed radiation treatment plan parameter against the respective parameter of the range of permissible values to derive an interlock output if the value of the proposed machine parameter is outside the respective range of permissible parameter values, and means responsive to the interlock output to prevent transfer of the out-of-range proposed machine parameter into the prescribed set of treatment plan parameters stored in said storage means.

* * * * *

20

25

30

35

40

45

50

55

60

65