

[54] APPARATUS FOR HOMOGENEOUS REFINING AND CONTINUOUSLY CASTING METALS AND ALLOYS

1,162,094 1/1964 Germany

OTHER PUBLICATIONS

[75] Inventor: Gale Ray Fritsche, Bradfordwoods, Pa.

Steel Production by the Electroslag Remelting Method, Leybenzon et al., USSR, 1963, pp. 29-31.

[73] Assignee: Sandel Industries, Inc., Pittsburgh, Pa.

[22] Filed: Dec. 27, 1971

Primary Examiner—J. Spencer Overholser

Assistant Examiner—John E. Roethel

[21] Appl. No.: 212,149

Attorney—Carother & Carother

Related U.S. Application Data

[62] Division of Ser. No. 824,589, May 14, 1969, Pat. No. 3,650,311.

[57] ABSTRACT

[52] U.S. Cl. 164/252

[51] Int. Cl. B22d 27/02

[58] Field of Search 164/52, 85, 252

An electroslag vessel for melting, refining and continuously casting alloy constituents in a single unitary vessel having a melting section offset from a casting section being separated by a dam with the casting section having a casting throat. Metallic constituents are fed into the melting section where they are melted to form a molten metal bath and thence refined to transfer over into the casting section to form a molten metallic pool. The bath and pool are blanketed by a molten flux bath through which heating medium is applied, as by electro-energized heating methods. The liquid-solid interface between the molten metal pool is controlled as to shape and level to thereby also control the level of both the bath and pool to be maintained substantially at the same level.

[56] References Cited

UNITED STATES PATENTS

2,445,670	7/1948	Hopkins.....	164/252
2,740,177	4/1956	Smart.....	164/85
2,734,244	2/1956	Herres.....	164/52
2,260,259	10/1941	Hopkins.....	222/185
2,380,238	7/1945	Hopkins.....	164/136
3,507,968	4/1970	Parsons.....	13/9
807,034	12/1905	Von Kugelgen et al.	164/52 UX
2,692,411	10/1954	Brennan.....	164/85 X

FOREIGN PATENTS OR APPLICATIONS

580,845	8/1959	Canada.....	164/85
---------	--------	-------------	--------

28 Claims, 17 Drawing Figures

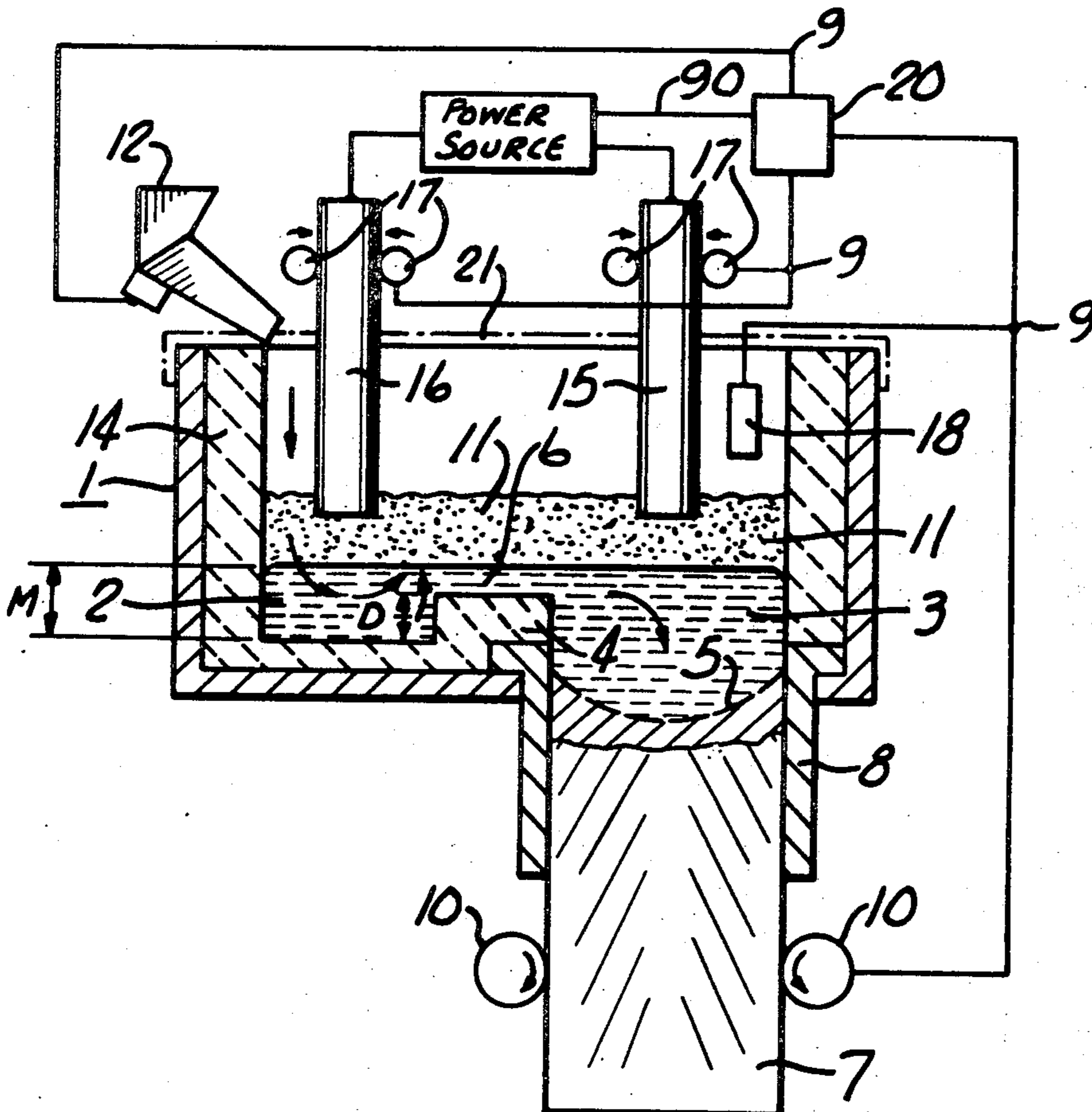

Fig. 1

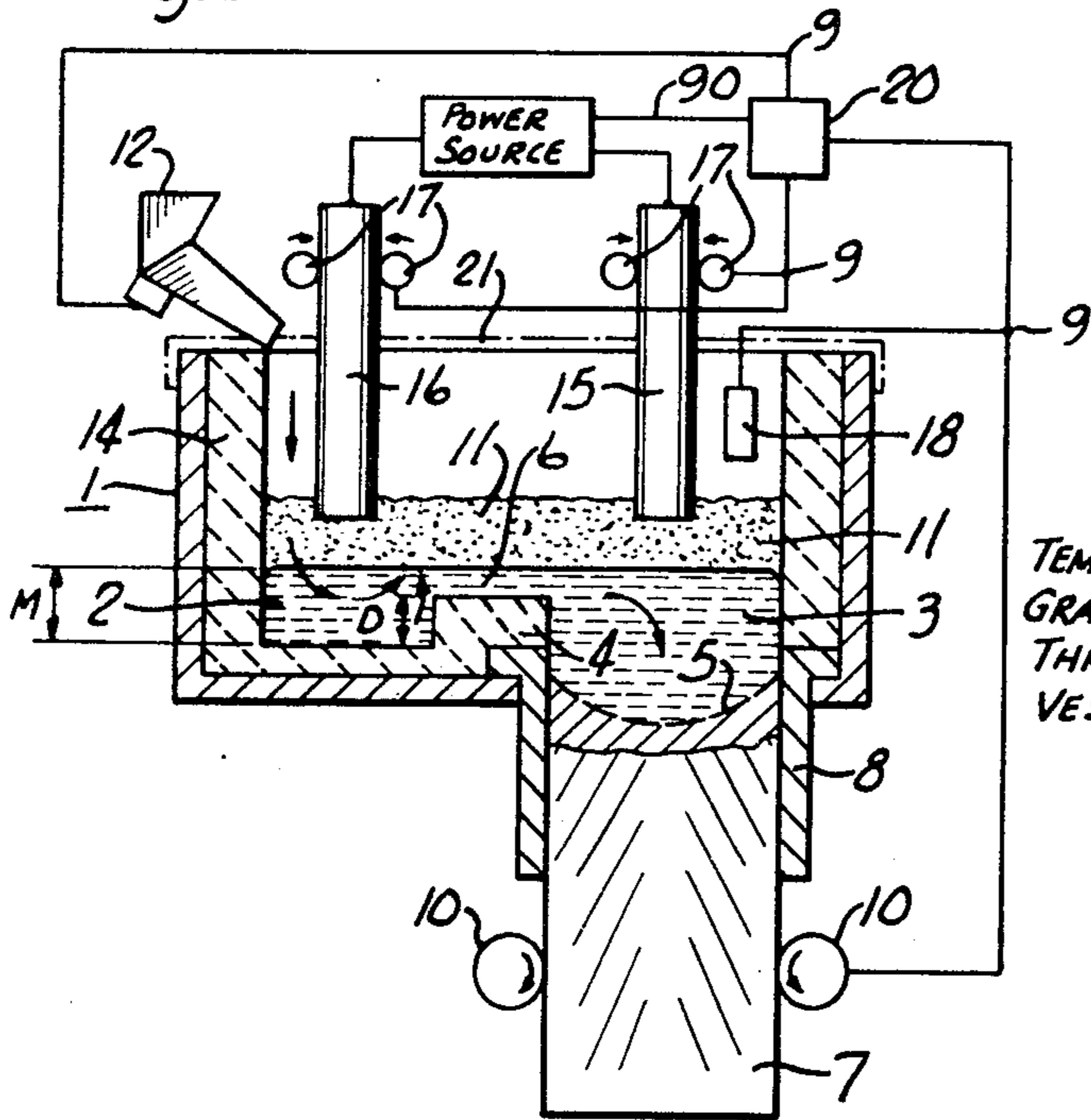

Fig. 3

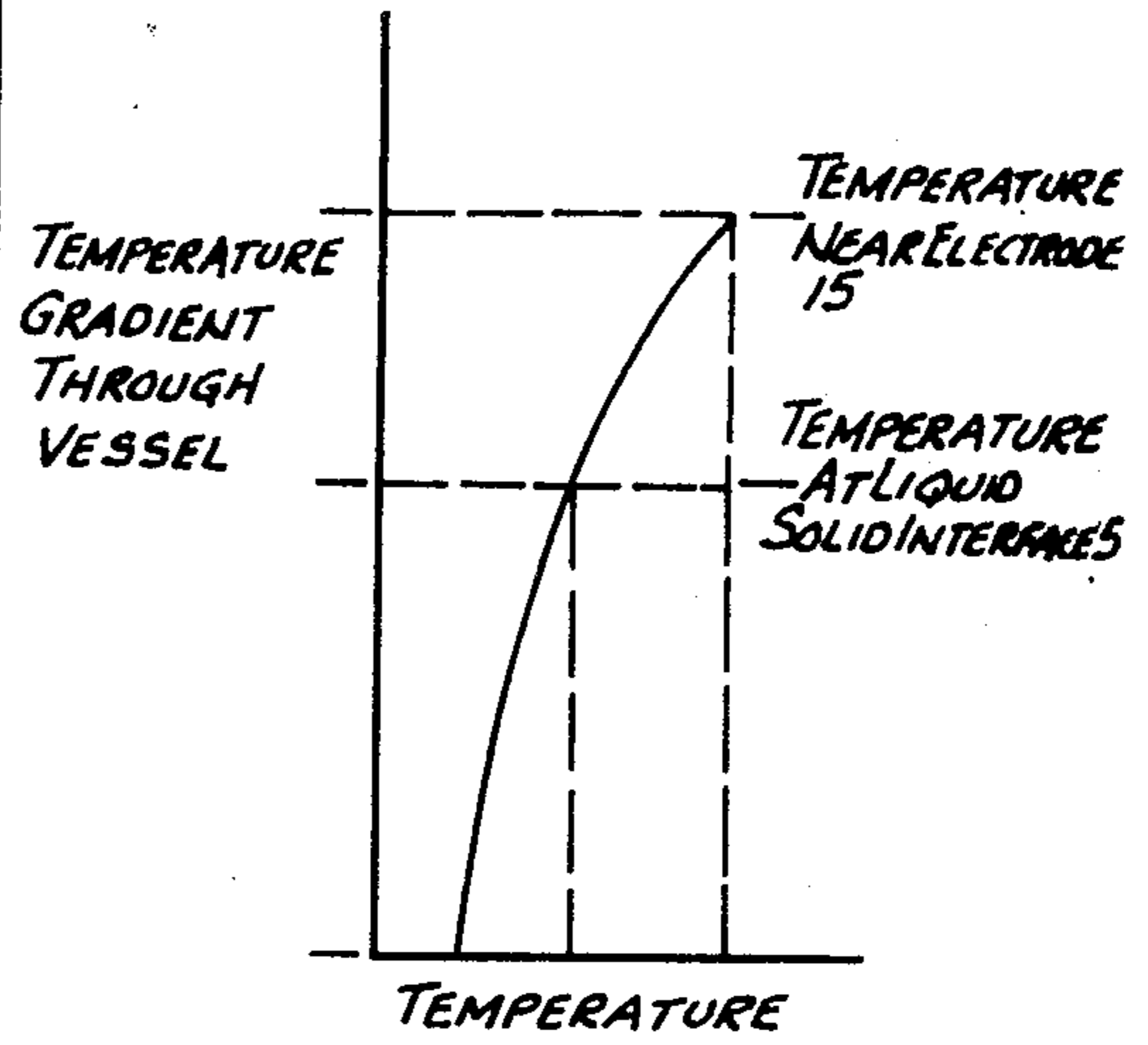

Fig. 4

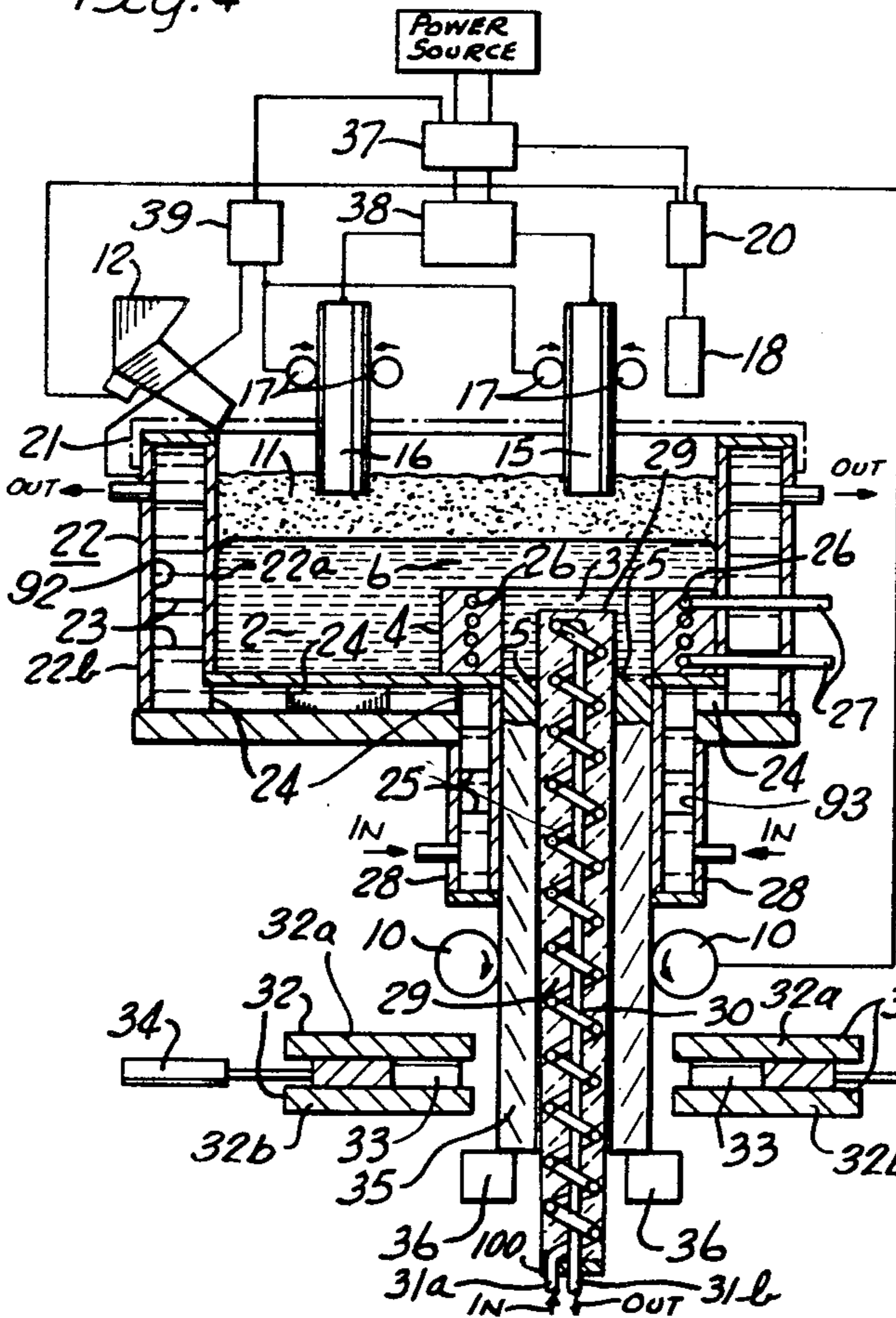

Fig. 2

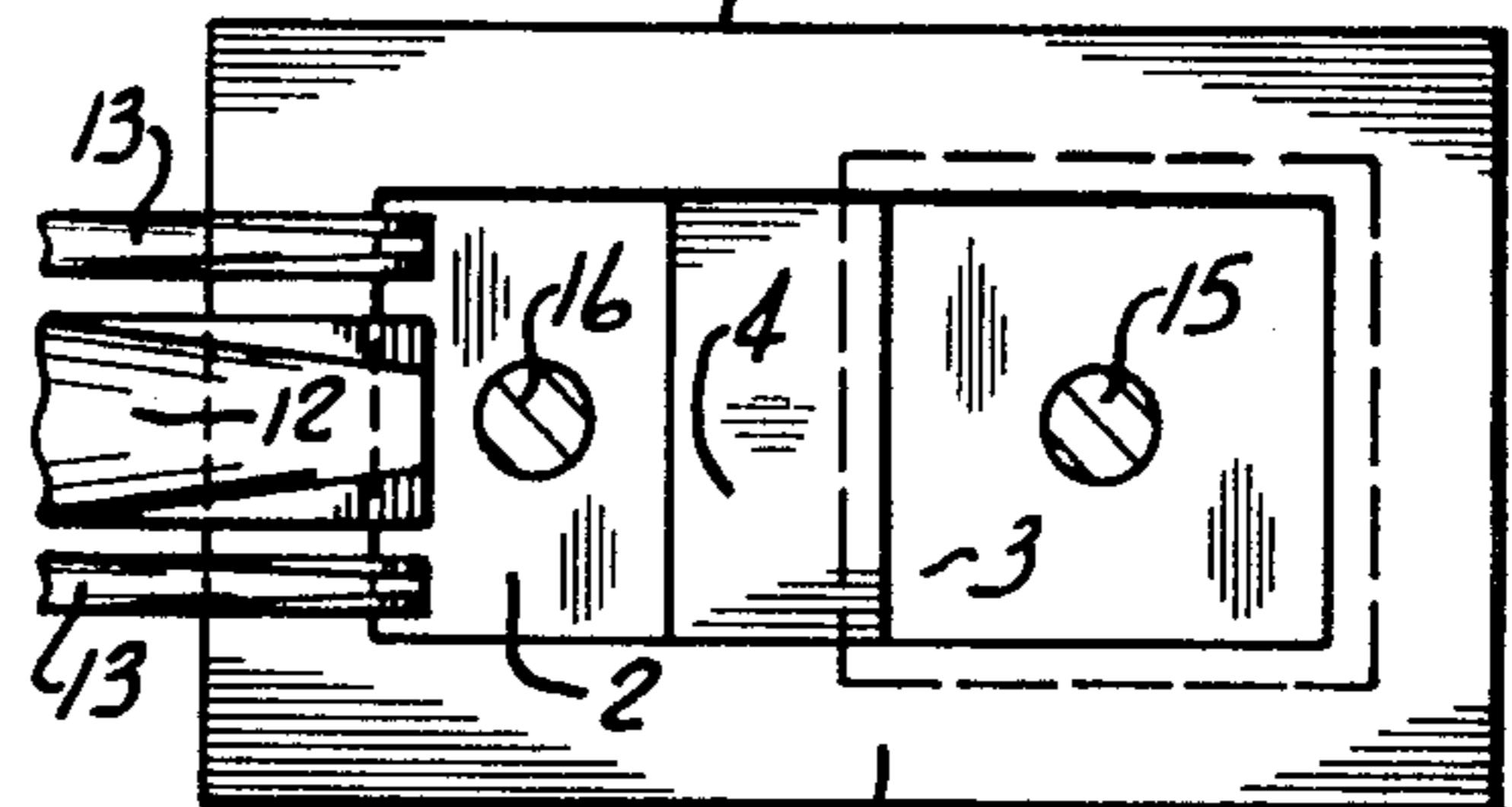
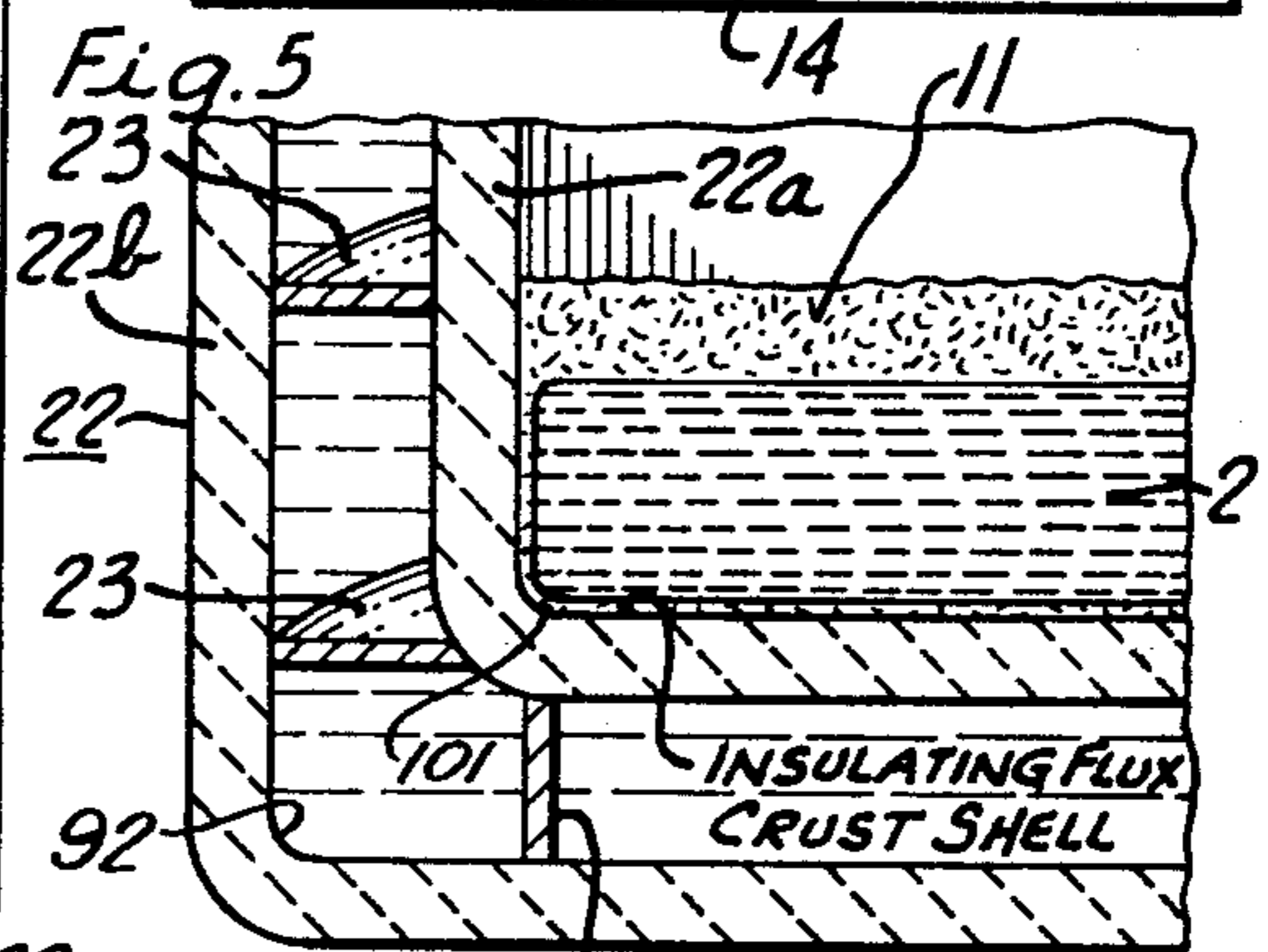
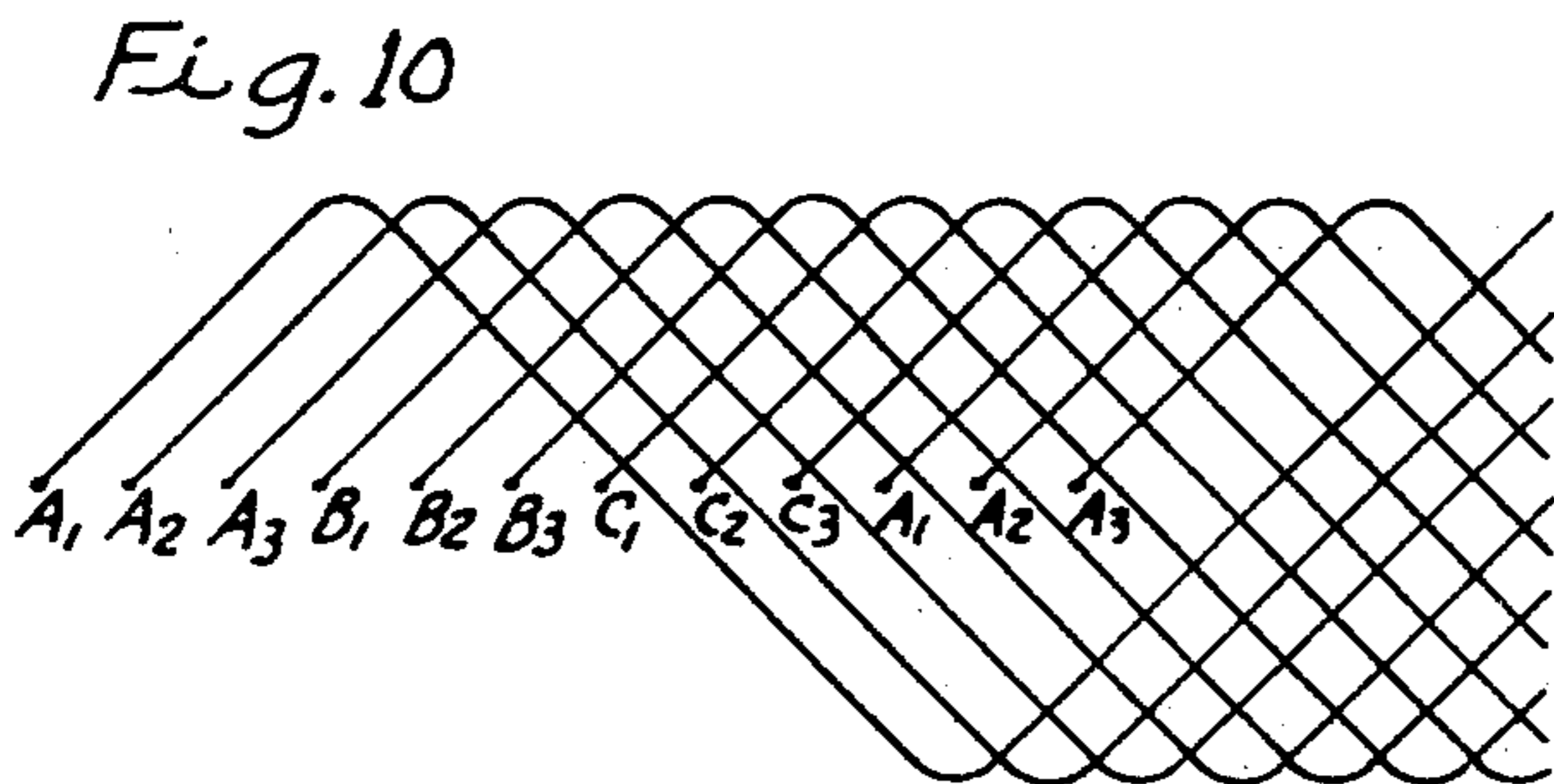
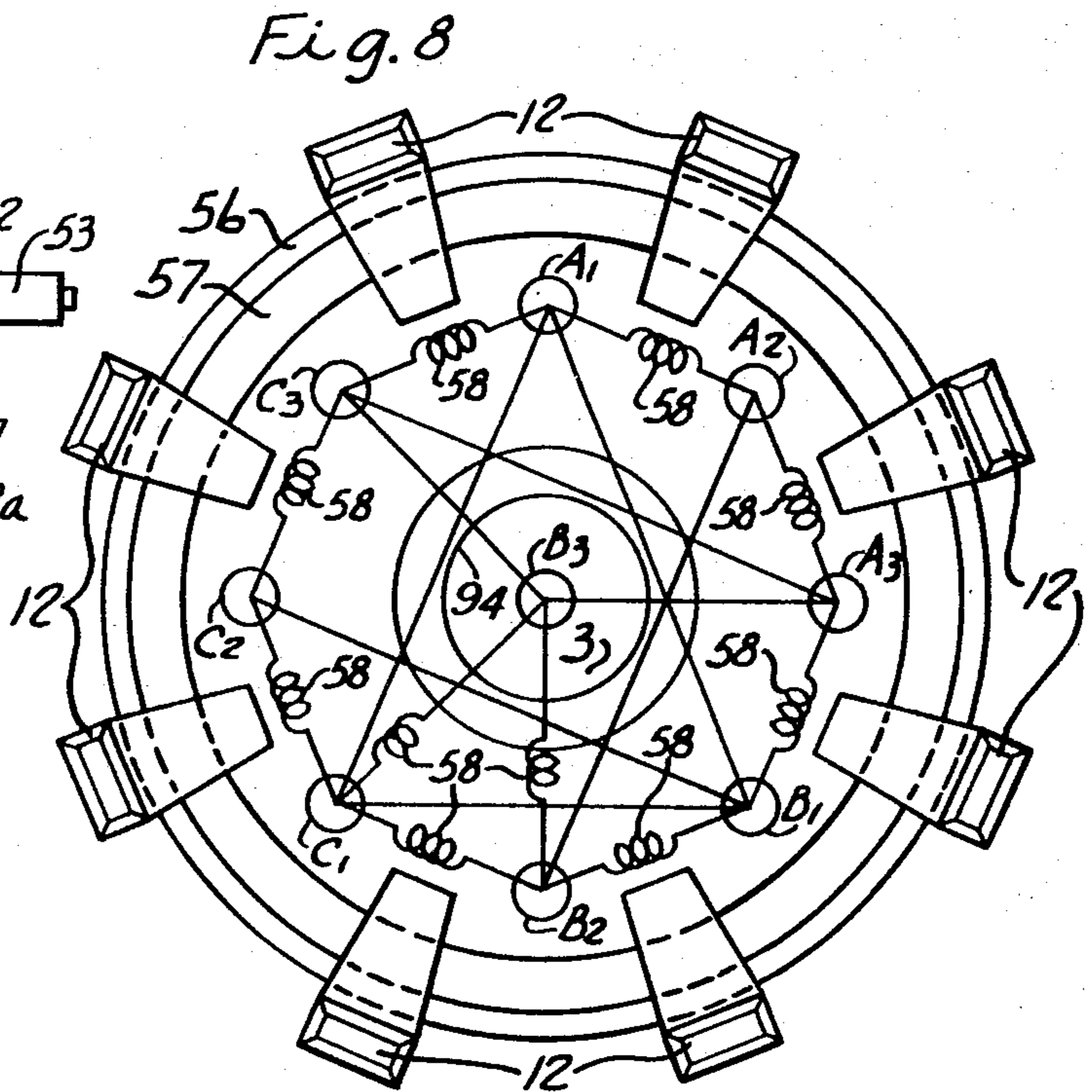
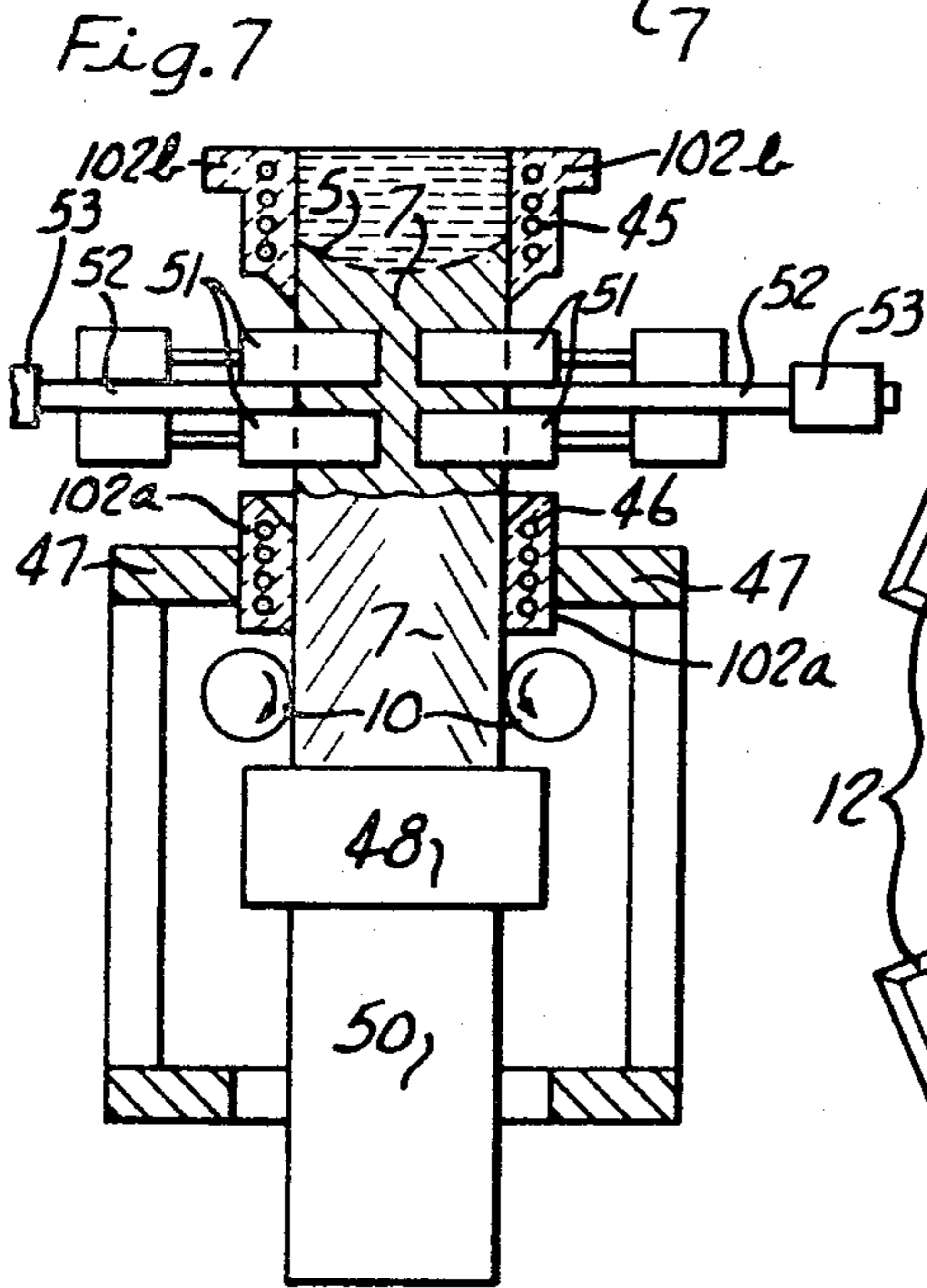
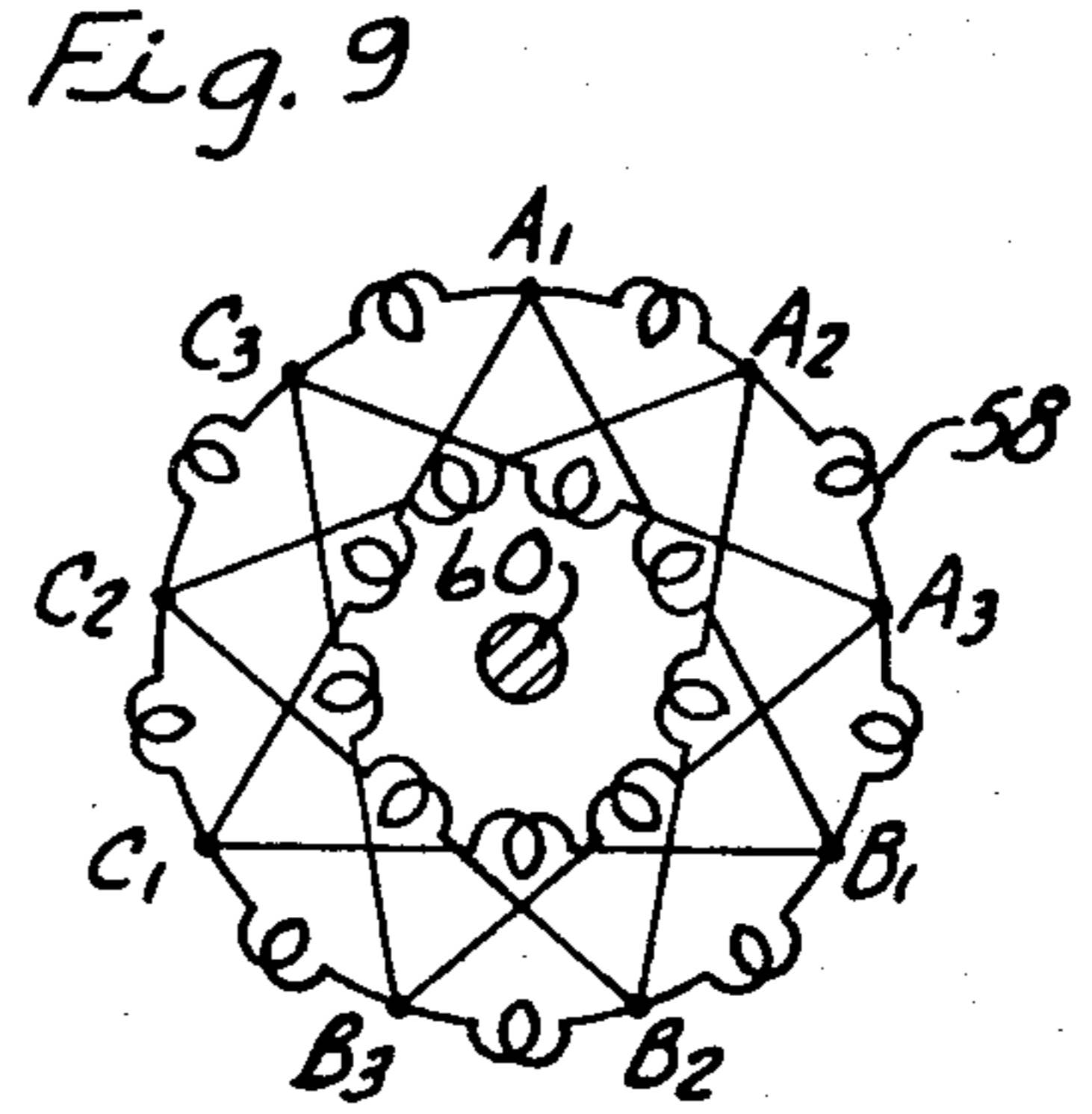
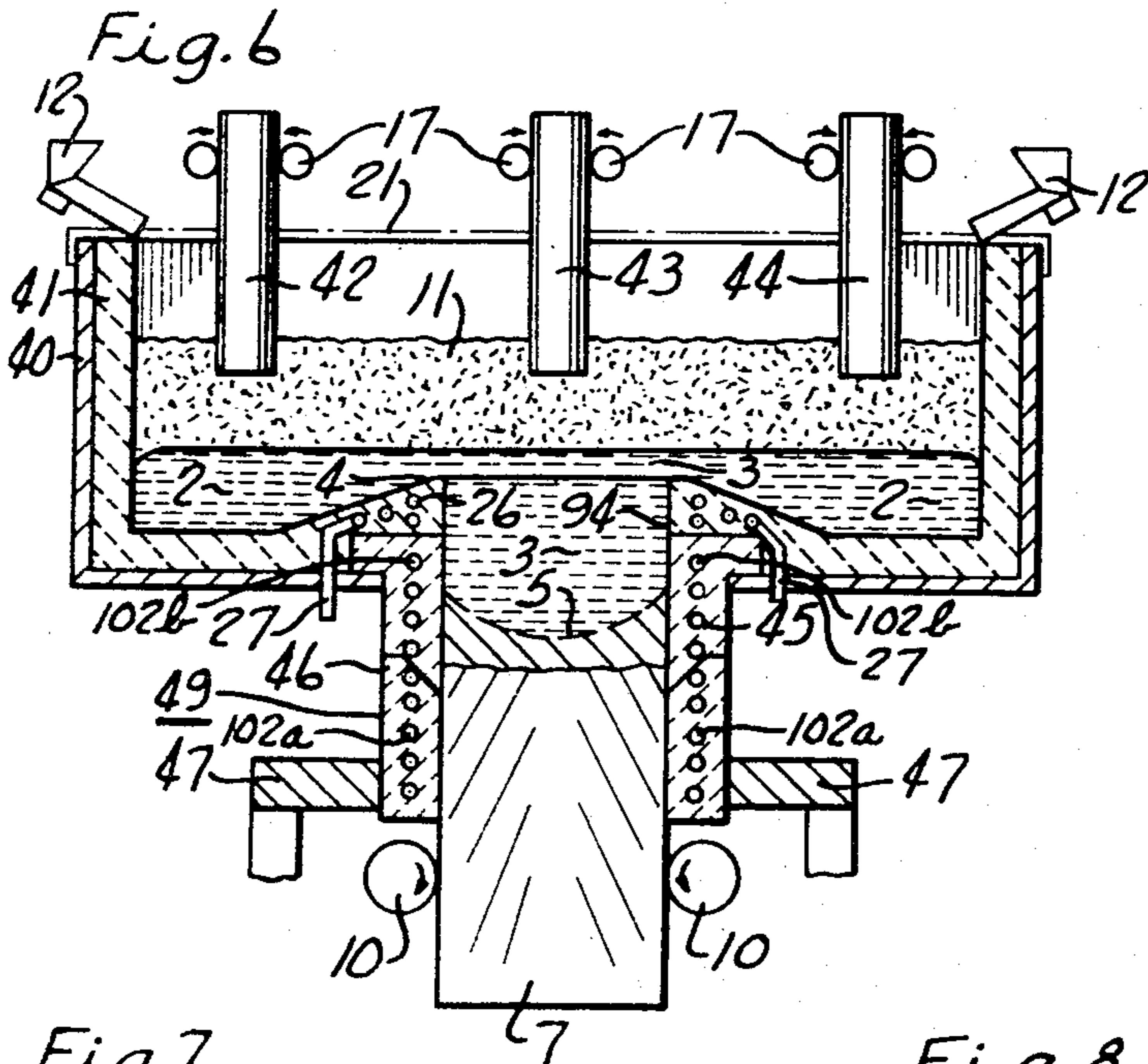

Fig. 5



INVENTOR.
 GALE RAY FRITSCHÉ
 BY
 CAROTHERS & CAROTHERS
 HIS ATTORNEYS



INVENTOR.
GALE RAY FRITSCHE
BY
CAROTHERS & CAROTHERS
HIS ATTORNEYS

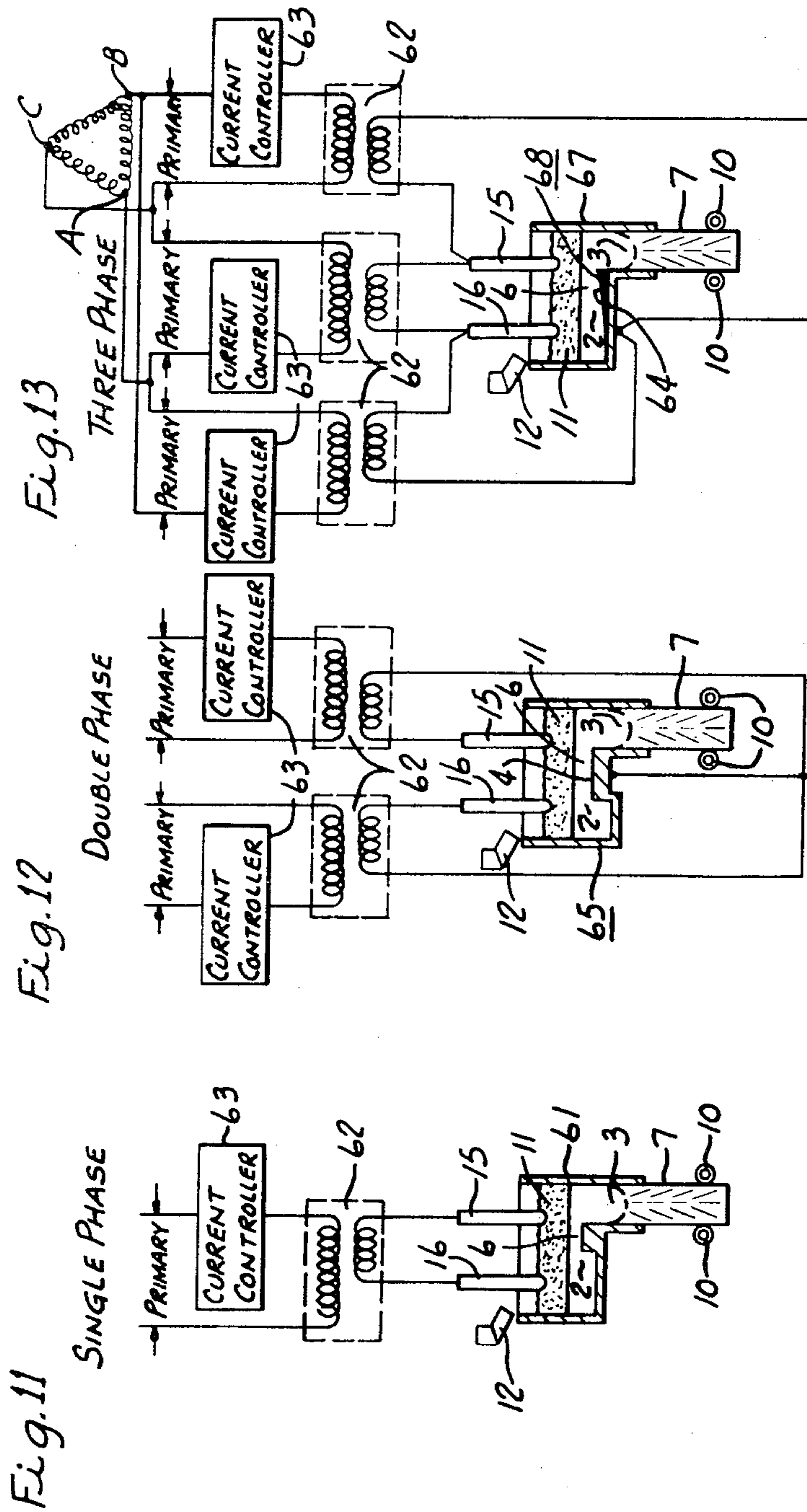

INVENTOR.
GALE RAY FRITSCHÉ
BY
CAROTHERS & CAROTHERS
HIS ATTORNEYS

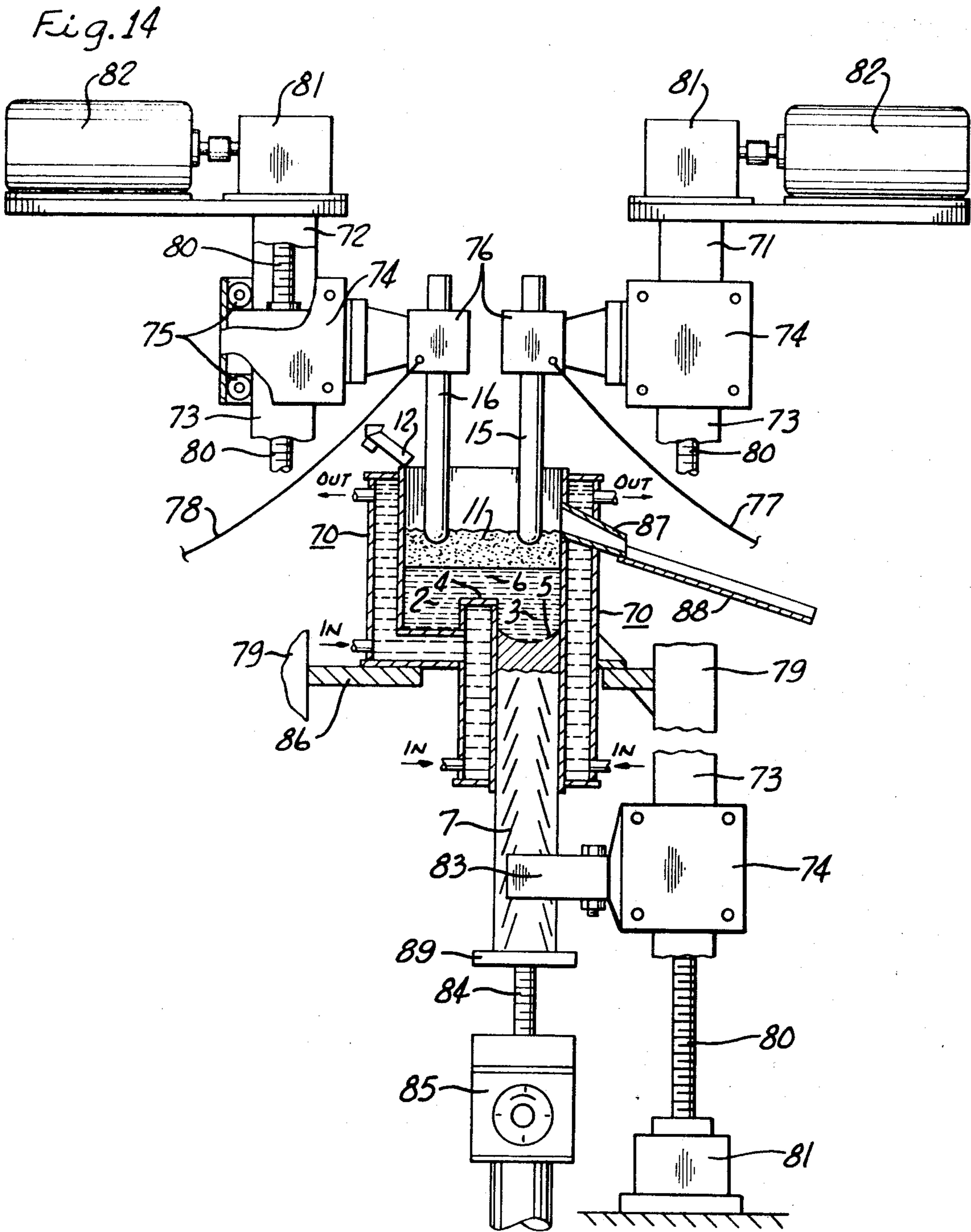

INVENTOR.
GALE RAY FRITSCHE
BY
CAROTHERS & CAROTHERS
HIS ATTORNEYS

Fig. 16

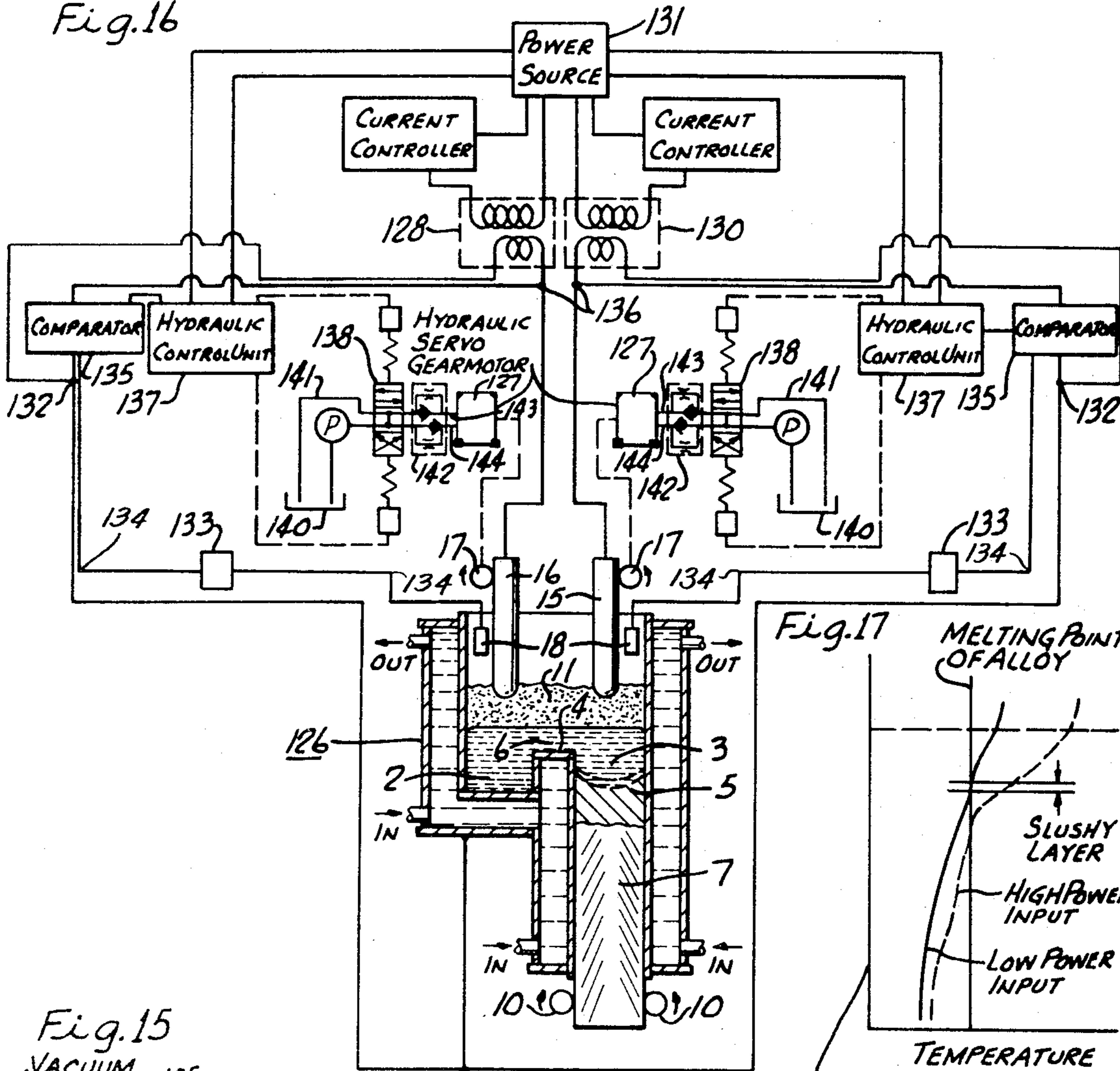

Fig. 17

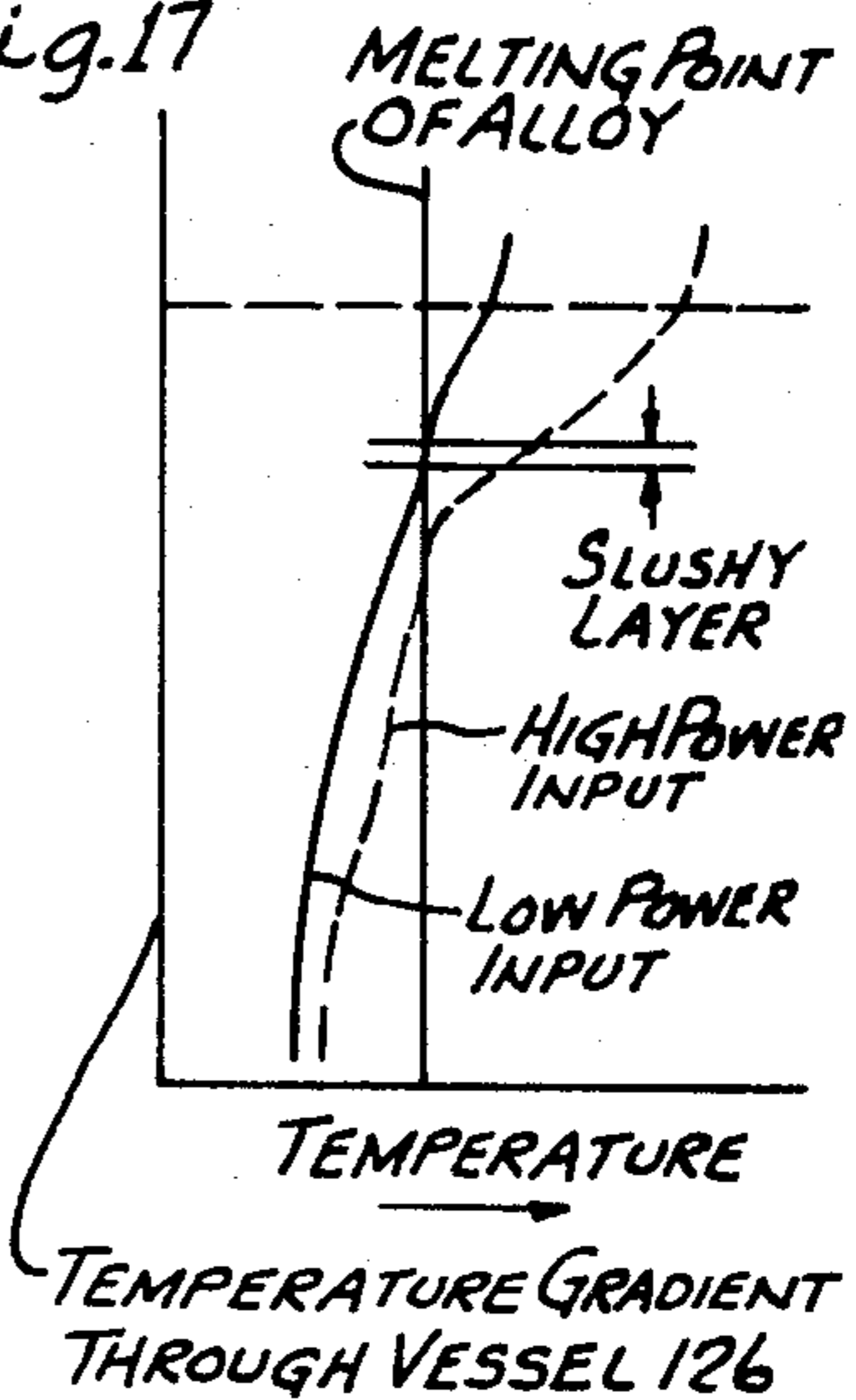
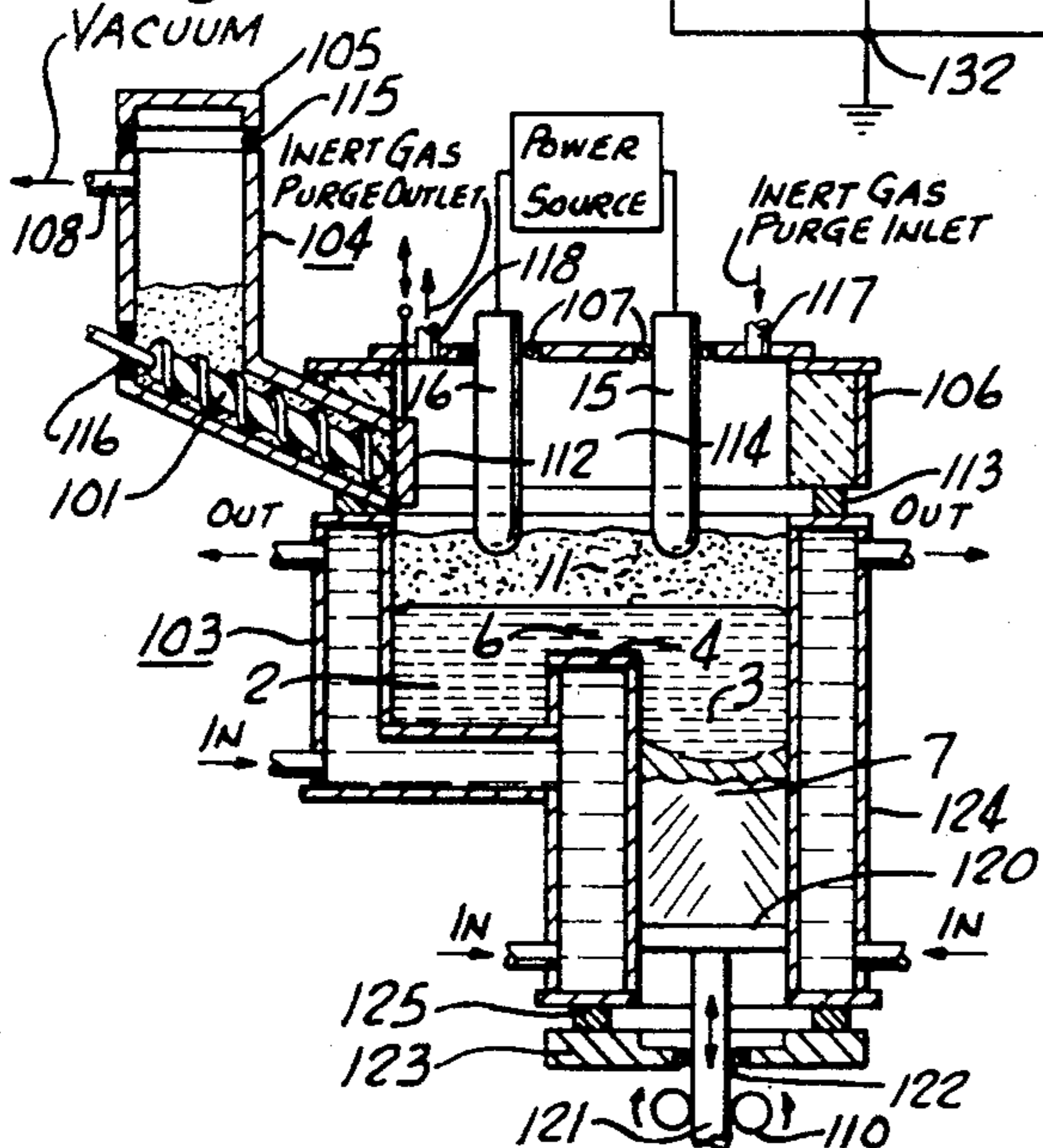

Fig. 15



INVENTOR.
 GALE RAYFRITSCH
 BY
 CAROTHERS & CAROTHERS
 HIS ATTORNEYS

APPARATUS FOR HOMOGENEOUS REFINING AND CONTINUOUSLY CASTING METALS AND ALLOYS

CROSS-REFERENCE TO RELATED APPLICATION

This is a division of Patent Application Ser. No. 824,589, filed May 14, 1969, now U.S. Pat. No. 3,650,311.

BACKGROUND OF INVENTION

This invention contemplates apparatus that permits a true continuous electroslag process wherein the alloy constituents can be continuously charged to the apparatus and heated to a high temperature and the electroslag flux can be continuously refurbished or changed in the apparatus, and the cast ingot can be continuously drawn from the apparatus and severed without interrupting the entire overall process.

An undesirable characteristic of the prior art is the inability to properly control the resistance heating through a consumable metallic electrode which is melted into a molten superheated flux bath or pool. Without proper and efficient control in heating, fusing, blending, refining, melting and subsequent cooling, there results non-homogeneous metal ingots, possessing higher impurity levels than desired. This has plagued the metal refining and casting art for many years resulting in the necessity of a two-step operation wherein the alloy is first refined and then formed into a consumable electrode which then is used in a second heated crucible process wherein an ingot is remelted and formed on a continuous basis. The U.S. Pats. to Hopkins, Nos. 2,369,233; Hopkins, 2,445,670; and Peras, 3,234,608, would fall in this category. Although Hopkins 2,445,670 appears to be a continuous operation, there lacks in his structure means to maintain uniform heat distribution by maintenance of the level of both the baths or pools in the melting zone and casting zone thereby imposing a "forced flow" of unrefined constituents from the melting zone to the casting zone by gravity or overflow.

Another problem that has plagued the prior art is arc discharging at the electrodes when submerged in the flux blanket, such as disclosed in Hopkins U.S. Pat. No. 3,067,473, which not only causes defects, such as cavities, blow holes, pores, etc., in the cast ingot but also permits unmelted inclusions to be presented into the ingot.

Another problem that has plagued the art has been not only controlling the melting process and the consumable metal electrode, but also taking into consideration chemical control, that is, tailoring fluxes to be utilized as the molten flux bath to properly refine the particular alloy that is desired to be produced and continuously cast.

The prior art structures and methods employed have been unable to make alloy additions during melting of a consumable metal electrode without causing defects, such as, inclusion stringers, alloy segregation, and coherent brittle phases in the cast ingot.

Two important examples of prior art references are the U.S. Pats. of Herres, Nos. 2,763,903 and Sunnen, 3,344,839.

Herres U.S. Pat. No. 2,763,903 lacks the use of a flux bath or blanket and cannot produce successfully an homogeneous ingot because of nonuniformity in heat input from the electrodes. This is particularly true at

the mouth of the casting section. There is no means provided for controlling the solidification in the casting section through control of the thermogradients and as a result, the ingot will not have the desired axial solidification structure and crystalline orientation at the liquid-solid interface.

Sunnen, U.S. Pat. No. 3,344,839, lacks control of the proper fusing and blending of the metallic powders adhering to the metallic strip or bar electrode in the molten bath in attempting to refine and concurrently therewith continuously cast an alloy ingot. The powder particles are freed from the electrode as it progresses into the molten bath because they progressively lose their magnetic attraction to the magnetic strip or bar electrode and are not given a complete opportunity to melt or otherwise fuse and blend into an homogenous manner and become entrapped in the solidifying unit being formed substantially directly beneath the molten bath. Thus, an impure, undesirable ingot is produced having unwanted inclusions. Since Sunnen utilizes a vertical arrangement with a consumable electrode directly above the casting area, it is a matter of necessity that he use fine particles rather than the granules so that these particles will melt quickly before they enter the casting area. This is the principal reason why undesirable inclusions are formed in the casting.

SUMMARY OF THE INVENTION

The basic objective of this invention is to produce on a continuous basis a super alloy having the desired metallurgical properties and impurity level including axial oriented grain structure. The orientation of the grain structure is controlled at the interface of the casting section by controlling the thermodistribution through the interface. This is done by controlling the heat input in the casting area which may be accomplished by electro-energized heating, and in addition, if necessary induction coil heating at the mouth of the casting section.

Provision is made for continuous refining in casting metal alloys under a molten flux blanket covering the molten metal bath by melting their constituents of the selected alloy to, first, metallurgically form, blend and refine the alloy in one zone or area and, then, withdrawing the refined alloy to another zone or area to continuously cast the same. Means are provided by which the refining and casting of alloys such as those known as "super alloys" is carried out in a single continuous operation.

Reference is made to this zoned refining and casting process as the "offset" method wherein a practical control referred to above, is employed in regard to heating and temperature distribution through the use of a molten flux medium as well as the employment of a solid flux crust on the surfaces of the ingot mold. The ultimate aim is to refine the metal alloy, which may control reactive elements, under controlled heat conditions while eliminating impurities and solid inclusions from entering the casting area and maintaining temperature uniformity at the mouth of and in the casting section of the ingot mold.

The offset method with adequate heat containment and distribution provides a practical and commercially accepted method of controlling the fusion and blending of the alloy materials before they are allowed to enter the continuously casting area. In this manner, unrefined and unmelted inclusions are not permitted to contaminate the ingot. The apparatus to be used in the off-

set method therefore becomes quite important to eliminate such ingot contamination and yet provide a single vessel which can be used in a continuous operation to melt, refine and continuously cast a metallic alloy. The important aspects of the electroslag vessel comprising this invention resides primarily in the maintenance of the molten surfaces of the baths or pools of molten metal essentially at the same level to impose upon the metal pool or baths, any lateral resistance to the natural flow of molten materials from the melting zone or section to the casting zone or section, such as might be caused by gravity due to levels of molten metal in the different pools or baths, or different levels for the melting and casting zones in the vessel itself as in the case of Hopkins U.S. Pat. No. 2,445,670.

Another important aspect is the application of uniform heat to the baths or pools in the electroslag vessel while controlling the liquid-solid interface developed in the casting throat thereby also maintaining the level of the baths or pools.

The electrical control of the crucible or vessel must be designed to supply sufficient power to maintain in a molten state the flux bath as well as melt the incoming metal feed. Also, there must be a balance of power input between the melting refining section and the continuously casting section so that the liquid-solid interface is maintained below the intermediate area of the ingot mold cavity.

The offset method is accomplished within and under an electroslag or an electrically energized molten flux bath that blankets and melts the constituents by functioning as a flux as well as a refining constituent so that part of the flux may selectively enter the molten alloy bath as an operation or "curing" constituent. The term "electroslag" referred to herein is a molten bath of flux or flux blanket which covers the molten metal feeding zone or area as well as the casting zone or pouring area, and this flux is known in the art as a slag or electroslag. Since the flux must melt constituents forming the alloy, the flux bath must be maintained at a higher temperature than the constituents. The temperature of the molten bath may be from ten to sixty percent higher than the melting temperature of the metal or metals being refined and cast.

The preferred flux bath is electro-conductive containing material such as calcium fluoride (CaF_2) and/or lithium fluoride in combination with one or more of the oxides of calcium, magnesium, aluminum, titanium, and silicon, which is heated by the resistance by the flow of an electric current passing between at least two electrodes. Consumable electrodes may be used and may contain additives to refine the alloy and, in fact, may be precast alloy electrodes. However, it is the main purposes of the present invention to eliminate the necessity of performing precast alloy electrodes and thus performing the refining operation and immediately thereafter continuing with a casting process.

Examples of molten conductivity values and the approximate melting temperatures of certain fluxes that may be used in the refining and casting process herein are as follows:

Flux Composition	Conductivity-ohm-cm			Melting Temperature
	1600C	1700C	1800C	
70% CaF_2 , 30% Al_2O_3	1.29	2.02	2.85	1270 \pm 10C
65% CaF_2 , 30% Al_2O_3 , 5% TiO_2	1.42	2.03	2.76	1290 \pm 10C
50% Al_2O_3 , 50% CaO	0.19	0.38	1.02	1340 \pm 10C

30% CaF_2 , 40% Al_2O_3 ,
17% CaO , 13% MgO

0.90 1.36 1.92 1320 \pm 10C

Thus, fluxing oxides are in addition which can be used to decrease conductivity and, thus, power consumption, and at the same time increase the melting point and viscosity and heating capacity of the process. Sodium oxide may be added to increase initial conductivity and, later on in the melting process, it volatilizes and, thus, prevents the necessity of making a later power consumption correction.

As mentioned, a flux layer or crust may be provided on the walls of the crucible or vessel in the vicinity of the molten bath to form a flux shell therein to aid in maintaining heat uniformity and minimize heat loss.

Metal and alloying components are fed into and through the flux blanket into the molten metal bath where they become heated from the uniformly heated flux blanket until the components as fed reach a molten state and thence become mutually soluble. There can be during this melting process a refining action, such as, removal of non-metallic materials to improve impurity by flotation, absorption, and reaction due to the presence of the oxidants having higher chemical potential than the undesirable impurities, such as, metal oxides. These metal oxides have already been referred to above.

From what has already been mentioned in connection with this summary, it can be seen that use of the process and apparatus herein, eliminates the necessity of prealloy electrodes which, by their nature, are limited in length and being readily consumable in the process, places a limitation on the total heat time of a production run. It is the purpose of this invention to employ nonconsumable electrodes to not only eliminate the necessity of limited production runs but also eliminate many of the problems of heat control previously mentioned in connection with the prior art. Furthermore, it is of great expense to prepare prealloyed electrodes which by their nature often require vacuum induction melting facilities. These electrodes, as such, have only been refined and do not have the metallurgical properties usually desired until they are again remelted under controlled heat conditions in a continuous casting operation. From the foregoing, it becomes further evident that the primary purpose of the present invention is to eliminate the necessity of initially refining the alloy by forming prealloy electrodes and thereafter in a second process producing a continuous cast ingot possessing the desired metallurgical properties including the desired grain structure.

Plasma arc, electric arc and electron beam heating of the flux bath may also be employed. All of these systems are representative as an electro-energized molten flux bath as employed herein. Melt rates can be increased by the use of supplemental heating within the molten metal bath in the melting and metal feeding area, such as by induction heating. The preferred methods of electro-energized heating are induction heating and arc heating. In the latter, the electrodes employed are generally maintained in contact with or just above the surface of the molten flux bath.

The temperature of the molten flux bath is controlled by temperature sensing means which regulate the current to the electrodes through the employment of a feedback temperature control system.

The metal and other constituents forming the alloy is fed to a melting vessel at a predetermined rate usually

commensurate with the rate of continuous casting and is maintained so that the melting power requirements are within the wattage capability of the melting vessel.

The molten flux bath heats these materials above their melting point which forms and maintains a molten metal bath below the molten flux bath as the latter bath segregates to the bottom of the melting vessel with the alloy constituents owing to the higher density of the molten metal. The flux bath and metal bath are separated by a distinct flux-metal interface due to the large difference in the respective thermodynamic properties of the materials making up these two different baths.

The molten bath is withdrawn from the feeding zone by a continuous casting process from a common molten bath of metal and is directed to the solidification area of this molten bath which is laterally disposed and separated from the feeding zone. This prevents the movement of unmelted solids to the solidification or casting zone and, therefore, eliminates the necessity for a cast ingot to be used as a remelt or consuming electrode, as previously indicated above.

The offset method is augmented by a weir in a cross dam below the molten surface to confine the feeding area from the withdrawing and casting area. The offset can be advantageously made into an annular dam with a surrounding feeding area of 360° in scope with the casting area in the center and controlled by a system of electrodes and energized to induce an annular movement to the molten metal in the annular feeding area due to operation of electrodes under the influence with a high frequency alternating current and with a central electrode provided in the central casting area. The height of such dams may vary from a few inches to one foot depending on metal feed rate to maintain uniform depth in the molten liquid above the top of the dam.

The withdrawal of the molten liquid in the casting area also creates movement to the molten liquid above to further aid in the refining of the molten metal alloy.

The molten metal is preferably continuously cast rather than being poured or run off to prevent oxidation of the hot metal alloy due to the surrounding atmosphere which would cause it to oxidize and thus change its consistency metallurgically since it will contain impurities in the form of oxides of the metals incorporated in the alloys being refined.

In the casting area, heat is extracted and withdrawn from the molten metal flowing down into the casting area continuously forming the ingot which is preferably, but not necessarily, shaped symmetrically relative to its cross-sectional center of mass and the vertical axis of the casting area. This central casting in the case of an annular feeding area provided in the vessel or crucible, functions as a whirlpool or driving force to aid in the movement and, thus, better refine the qualities in the molten metal bath.

The formed ingot is extracted preferably at a continuous rate proportional to that of the feeding of the constituents to maintain a substantially constant level of the molten metal bath in the cavity of the vessel or crucible. This is aided by the axial nonconsumable electrode submerged in the flux blanket over the axial center of the casting area in the annular feeder embodiment referred to above.

The heat supplied to the apparatus is carefully regulated and the rate of cooling in the casting area or zone where the ingot is being formed is regulated to control the depth and shape of the liquid-solid interface that is

located at the top of the continuously cast ingot. It is preferable to have a shallow interface to accurately shape the formation of the ingot and, in this matter, control the homogeneity of the ingot microstructure to align the crystalline structure of the metal longitudinally of the ingot which is highly important in connection with the working characteristics to which the alloy ingot is subjected to in later commercial applications. This is an important object of this invention in that it involves the heat of the control of this process to produce such commercially acceptable alloy ingots, particularly those employing super alloys, having the proper longitudinally aligned grain structure which is necessary in most commercial applications.

Supplemental induction heating above the liquid-solid interface can provide an additional degree of control over the solidification and casting process in the casting area.

As previously stated, electroslag molten flux bath blankets this whole surface of the molten metal and this molten flux bath being electrically conductive becomes very hot due to the electric current which passes from one or more electrodes into the molten metal bath and assists in properly containing the developed or generated resistance heat to melt the feed metal while providing metallurgical cleansing of the molten metal by carrying off unwanted impurities by evaporation, absorption, and flotation. Thus, it is preferable to allow a portion of the molten flux to be continuously discharged while simultaneously being refurbished at the opposite side of the bath adjacent the feed area or areas so that the revitalized flux is more effectively moved into the refining area of the alloy product. In this manner, the chemical potential of the flux is maintained at a sufficiently high level to provide satisfactory refining action.

The depth of the molten electroslag or flux bath varies with the alloy being processed and the flux constituents. A light flux bath of one or two inches is adequate for some low temperature alloys whereas other alloys because of their high temperature melting points may require from eight to twenty inches thickness in the flux bath. The latter is more favorable for high temperature alloys containing reactive elements.

The metal alloy materials, which may consist of chunks, granules, or powder, are fed into the baths where they penetrate the molten flux and commence to become partially melted. They may further penetrate into the molten metal bath in a semi or solid condition and therefore cause intense localized cooling and agglomerate together without thorough melting. This is why it is necessary to have an offset in the form of a dam or other means the height of which is sufficient to retain such unmelted particles or agglomerates in the feeding area until they have had an opportunity to be blended and fused to completely melt and metallurgically synthesize in forming the refined metal alloy. This is one affirmative reason why it is highly undesirable to utilize consumable electrodes over the casting area, since unmelted semi-solid particles may fall directly into the casting area thereby forming inclusions in the ingot making the ingot impractical for commercial application.

In the use of an offset structure in performing the process comprising this invention, impurities are prevented from gathering in the center of the ingot being formed in the continuous casting section and by con-

trolling the formation of the ingot and the liquid-solid interface in the casting section, cracks or otherwise referred to dendrites, can be prevented from growing outwardly from the longitudinal axis of the ingot.

The apparatus in the form of a melting vessel with an annular dam, previously referred to, provides an additional advantage in that it may conveniently contain a high frequency induction coil to control the temperature of the throat or vortex of the casting area wherein there commences the flow of the molten metal bath into the continuous casting area which regulates the potential speed of withdrawing the metal into the casting area by the amount of heat transferred from the molten metal to initially form and thereafter control the dished-shaped interface and its vertical location within the casting area.

The location of the interface can be changed by controlling the temperature in the molten metal bath above the casting and to a lesser degree the arrangement and movement of the coolant in the mold through which the continuous casting is formed. Thus, control can be maintained whether the casting area is heated by non-consumable electrodes or by high frequency stimulation in the surrounding annular structure in the area of the dam or in the casting section per se.

The casting mold inner surface is coated by the casting process which is conducive to withdrawing the continuously cast ingot and creates a withdrawal or flow of the molten metal to the casting area as previously indicated. After the casting ingot has come of sufficient weight, it must be supported and drawn by, for example, the lowering of the supporting elevator or screw lift.

The casting mold may be severed at a point where the ingot is solidified but still hot enough to be hot sheared with little difficulty. The sheared portion may be dropped away and the stub of the cast ingot continues to move into a funnel-shaped opening forming a lower section of the casting mold to continue the casting process without interruption. Independent lateral embracing clamps engage and move with the ingot as the cutting or severing occurs, after which it is withdrawn and the lower mold section is moved upwardly into position to engage and encompass the stub.

The combination of the magnetic stirring action and the phase relation of the electro-energized molten flux in the feeding area as well as the offset withdrawing of the molten metal by continuous casting creates a metallurgical refining of the product in this imposed lateral partially resistive movement which is novel in the vessel herein disclosed and was not possible in the prior art where feeding and casting are carried on in an axially arranged alignment.

When feeding the constituents in powders, granules, chips, chunks, pieces and bars of stock, control of the weight and volume must be maintained by the use of controlled vibratory feeders and vibratory gravimetric feeders which are calculated to weigh the materials as they are fed. Such control, although not extremely sophisticated, can be made to accurately measure the supply per unit of time which, when coordinated with the weight and volume of the casting produced, provides accuracy in the metallurgical make-up of the alloy.

By continuously monitoring the chemical content of the casting, and by continuously adjusting the proportions of the alloying components, the variations in the

chemical content in the cast ingot can be maintained with narrow limits which will provide a uniformity never before possible in using the conventional consecutive two heat process for producing super alloy ingots of low impurity and desired grain structure.

Other objects and advantages appear hereinafter in the following description and claims.

The accompanying drawings show, for the purpose of exemplification without limiting the invention or the claims thereto, certain practical embodiments illustrating the principles of this invention wherein:

FIG. 1 is a diagrammatic view in vertical cross section of a melting vessel or crucible structure comprising this invention having a confined feeding area separated from the continuous withdrawing and casting area.

FIG. 2 is a graph showing the temperature gradient through the vessel or crucible, that is, through the molten flux bath, molten metal bath, the liquid-solid interface and the cast ingot in relation to the vessel structure shown in FIG. 1.

FIG. 3 is a diagrammatic plan view of the vessel or crucible structure as shown in FIG. 1.

FIG. 4 is a vertical sectional diagrammatic view of a continuously melting and casting vessel structure comprising this invention wherein the casting section or area is provided with an internal mold mandrel to produce hollow ingots.

FIG. 5 is a vertical sectional view of the portion of the structure shown in FIG. 4 showing in better detail the formation of an insulating flux crust shell on the inner surfaces of the mold cavity.

FIG. 6 is a vertical sectional diagrammatic view of a continuous melting and casting vessel structure wherein there is provided an annular feeding area offset from a centrally but lineally symmetrical throat forming the entrance to the casting section or area, the induction heating coil of which is independently heated.

FIG. 7 is a diagrammatic view in vertical section of the casting section or area of a continuous casting vessel wherein the casting mold is separable to hold secure the continuously cast ingot upon the application of a hot shear operation.

FIG. 8 is a diagrammatic plan view of a continuous melting and casting vessel structure wherein the vessel is of the type shown in FIG. 6 and provided with a plurality of electrodes connected in multiphase in circular fashion, adjacent and above which are provided in an annular series of vibratory feeding conveyors.

FIG. 9 is a symmetrical diagram of the electrode connections that may be employed with the melting and casting vessel of FIG. 8.

FIG. 10 is a graphic illustration of the phase sequence of the electrode connections shown in FIGS. 8 and 9.

FIG. 11 is a diagrammatic view of an offset vessel with a single phase arrangement for heating a continuous melting and casting vessel of the type illustrated in FIGS. 1 and 4.

FIG. 12 is a diagrammatic view of an offset vessel with a two phase arrangement for a continuously melting and casting vessel of the type illustrated in FIGS. 1 and 4.

FIG. 13 is a diagrammatic view of an offset vessel with a three phase arrangement for a continuously melting and casting vessel of the type illustrated in FIGS. 1 and 4.

FIG. 14 is a diagrammatic view in vertical cross section of a continuous melting and casting vessel structure wherein there is provided a continuous flux discharge together with specific controls for the electrodes and the continuous casting process.

FIG. 15 is a diagrammatic view in vertical cross section of an offset melting and casting vessel having a material feeding facility as well as being purged with an inert atmosphere.

FIG. 16 is a diagrammatic view of electrode positioning control utilizing a voltage feedback signal for maintaining a constant power input and thus uniform controlled heat in the vessel.

FIG. 17 is a graph illustrating the temperature gradient through the vessel of FIG. 16, that is, through the molten flux bath, the molten metal bath, the liquid-solid interface, and the cast ingot, as affected by power input.

Referring to FIG. 1 of the drawings, the vessel or crucible shown at 1 is provided with an outer metal structure with an inner wall refractory liner 14. A plan view of this vessel is illustrated in FIG. 2. A particular feature of this vessel is the provision of the feed area or section 2 and the continuous casting area or section 3, which are spaced from each other as illustrated and separated by an offset in the form of a dam 4. The dam 4 extends upwardly above the bottom liquid-solid surface of the vessel in the feed area or section 2 and is positionally above the interface 5 of the casting area or section 3. The distance from the top of the dam 4 to the bottom of the feed area is indicated by D and the depth of the molten metal bath or pool 6 is indicated at M.

The interface 5 is the point of formation of the casting of the continuous ingot or billet 7 which starts within the casting area or section 3 and extends downwardly through the water cooled mold section 8. After passing through a sufficient length of the water cooled mold section 8, the cast ingot 7 becomes sufficiently solidified and cooled to permit it to be exposed to the atmosphere and may be treated with water sprays as it progressively moves out of the mold section 8. The ingot pinch rollers or extractors 10 engage the opposite sides of the ingot 7 and are motor operated to produce a withdrawing action on the ingot 7 from the mold section 8.

The insulated vessel 1 retains a molten electro-slag or molten flux bath 11 above the molten metal bath 6. The molten flux bath being materially lighter in density than the molten metal bath floats on the surface of the molten metal bath 6. The materials making up the alloy are supplied by the vibratory or gravimetric feeder or conveyor 12 which vibratory feeder is supplied with adequate controls for accurately measuring materials per unit rate of time. An example of such a gravimetric feeder system is illustrated in U.S. Pat. Nos. 3,221,827 and 2,863,589. Small feeders 13 indicated on opposite sides of main feeder 12 are vibratory feeders for supplying the flux constituents for supply and refurbishing the molten flux bath. As previously stated, the molten flux bath 11 is maintained at a temperature higher than the melting point of the materials supplied to the molten metal bath 6 so that when they are fed by the vibratory feeder 12 to the top of the molten flux bath where they will intermingle and mix through the flux layer and subsequently melt as they pass into the feed area 2.

The constituents for the alloy being cast, that is, the base material, scrap and alloy additions, are preferably

supplied and continuously charged in dust, granules, nut size or chunks or even consist of larger portions of a precast ingot of the same material. As these materials are not supported by the molten flux bath 11, they will drop into the molten metal in the feed area 2 and there descend to the bottom of the vessel until they become molten, at which time they will be caused to circulate with the metal flow. The smaller and lighter sized materials may be melted by the molten flux bath before they actually reach the molten metal bath.

Although the vessel 1 is shown to be provided with a liner, it may be water cooled such as indicated in FIG. 4. Many other different characters of vessels or crucibles are shown and described herein.

The molten flux bath 11 is preferably heated by the electrodes 15 and 16 which in this instance are shown to be of circular cross section and are fed by electrode feed rollers 17 driven at substantially constant speed by suitable drive means such as a motor and gear drive to one of the rollers 17 of each of the pair of such rollers. These feeder rollers would be controlled according to the necessary heat consumption, capacity of production run of the vessel 1, and upon the material content therein. The electrode 15 which extends over the casting area 3 would always preferably be a nonconsumable type electrode, such as a tungsten or graphite electrode, secured to a water cooled hanger to reduce the temperature of the support and current connection to the tungsten electrode. Such an electrode, or a similar graphite electrode, would be regulated up and down in the molten flux bath to the proper degree to produce the proper temperature gradient in the bath for melting and performing the molten flux bath operation. The second electrode 16 is also of the nonconsumable type; however, it is quite possible that this electrode be a precast ingot of the same alloy material being cast in the vessel. The feeder motor 17 of the consumable electrode 16 would have to be independently operated so as to produce a constant feed of the electrode into the molten flux bath commensurate with the rate of melting of the consumable electrode 16. As mentioned, it is generally highly undesirable to use a consumable electrode at 15 since occasional chunks or pieces may be precipitated from a consumable electrode, which, in view of the vertically aligned portion of electrode 15 over the casting area would fall directly into the casting of the ingot. This is the main problem that has been experienced in the process of Sunnen, U.S. Pat. No. 3,344,839. Chunks, foreign matter or impurities that are precipitated into the casting of an ingot will affect the properties of the cast ingot which is the reason for a consumable electrode over the feeding area 2 when using such an electrode in the offset system comprising this invention wherein these impurities would only fall directly into the feed area 2 and not into the casting area 3.

As shown in FIG. 1 the alloy material is fed by means of one or more vibratory feeders 12 and the flux is fed by means of the vibratory feeders 13 into the vessel feed area where the alloy materials, when they reach the molten flux bath, can only pass through this area before ever finally arriving at the feed area 2 of the vessel.

A thermal sensor indicated at 18 may be suspended in different portions of the vessel or crucible for reading the temperatures of the molten flux bath or even indicate the depth of the bath, which temperature infor-

mation is supplied to the amplifier and controller 20 which, in turn, through independent circuits, may be made to control the feeders 12 and 13 as well as the electrode feeders 17 and the ingot extractor rollers 10 as indicated by the various circuit control lines 9 illustrated in FIG. 1. The controller 20 of the sensing device 18 is provided with different circuits for the purpose of operating each of the feeding mechanisms 17 as well as the ingot extractor mechanism 10. Controller 20 may be also employed to change the temperature by a control through the power source as illustrated by line 90 connected to the power source. As previously stated, the power source is preferably that of an alternating current type when electrodes are used regardless of whether they are of the consumable or nonconsumable type. As is well known, the alternating current may be of the high frequency type to aid in causing a stirring action in the molten metal bath 6.

A cover 21 is shown in dotted lines to enclose the vessel with the exception of the positions immediately beneath the feeders and sensor 18 as well as around the electrodes 15 and 16. This cover is preferably made of an insulating material and will retain in the chamber 11 above the molten flux bath an inert gas which may be supplied through the cover at a constant rate and discharged through the openings provided therein for the feeders 12 and 13. A purge of inert gas is not of necessity in the present invention since the flux bath 11 blankets the molten metal bath 6 preventing oxidation from being carried on in the metal bath. However, in the case of highly reactive alloys, it is preferable to purge chamber 9, with an inert gas to keep the oxygen above the flux bath at a low level. An example of a situation where an inert gas purge is desirable is the case of titanium alloys.

As shown and previously described, the alloy materials are fed to the molten flux bath 11 from whence they are at least initially melted and may pass through the molten flux bath and enter the molten metal bath 6 and become fused, blended and refined while passing through the molten flux bath. Some of the reactive materials added to the flux bath are added from the flux to the molten alloy as the alloy initially melts. Thus, some of the alloy materials fed as well as some of the reactive materials making up the molten flux bath have an opportunity to reach a thermodynamic state wherein their elements react to perform the refining of metal alloy in the molten metal bath 6. This electroslag refining process utilizing the offset method will improve the material quality and also the product yield of the alloy. Such alloys are known as high performance special purpose alloys such as, super alloys, including titanium alloys and even titanium metals. Examples of such materials are listed hereinbelow in the following table as they are known by trademark in the industry and market places.

Group I - Materials Containing Reactive Elements

1. Inco 200 series
2. Inco 300 series
3. Monel
4. Maraging Steels, 18Ni and 12Ni
5. A-286
6. Incoloy 825
7. Rene 41
8. Inco 718
9. Hastelloy X and C
10. Discaloy

11. Udimet 500 and 700
12. Titanium Alloys (Ti-6Al-4V, Ti-15Mo, Ti-2Cr, Pure Ti, Ti-13V-11Cr-3Al, Ti-5Al-2.5Sn-5Zr-2Al)
13. Inco Nickel 204, 205, 220 and 225
14. Inco Perma Nickel 300
15. Inco Dura Nickel 301
16. Monel Alloy 404
17. K-500 and K-501
18. Inco Nelx - 750
19. Ni-Span-C 902
20. Nickel base super alloys

Group II - Aircraft Quality Materials Not Containing Reactive Elements

1. AISI 4100 series materials
2. AISI 4300 series materials
3. 52100 bearing steel
4. Ladish D6AC
5. 300M Steel
6. 9 Ni-4Co Steels
8. H-11
8. 609L Stainless
9. Maraging Steels 18Ni and 12Ni

The electrical resistance level of the molten flux converts the electric energy passed therethrough to thermal energy. The thermal energy developed is conditioned on this resistance level and the power input supplied to the electrodes. This heat is not only used to maintain the temperature of the molten metal bath 6 but also to melt the alloy materials that are fed through the molten flux bath into the feed area 2. The proper balance in the heat of the molten metal below the electrode 15 must be maintained to properly position the liquid-solid interface 5 in the continuously casting mold section 8. This balance is maintained by having a larger metal pool at this particular position and also by controlling and balancing the cooling effect brought about by the water cooled mold section 8. By maintaining such a proper balance the interface 5 of the continuously cast ingot 7 will be maintained shallow, as shown, which is indicative of the formation of longitudinally disposed crystalline growth that materially aids in later longitudinal working of the ingot. Thus, approximately half of the heat requirement is employed to maintain a molten metal bath and approximately one half to three-fourths of the heat requirement is employed in melting the metal feed and maintaining the molten flux bath and the balance is employed as a loss of heat through the continuous casting process which induces the loss of heat by radiation, conduction and convection through the operation of water cooled mold 8.

The electroslag is formed by the use of flux compositions such as calcium fluoride and aluminum oxide titanium oxide and calcium oxide, magnesium oxide. Many other different oxides and well known fluxes having desired refining properties may be employed in combinations to meet a particular situation, such as, (a) 60 to 80% CaF₂ plus 40 to 20% Al₂O₃ for air craft quality steels; (b) 30 to 50% CaF₂ plus 20 to 40% Al₂O₃ plus 10 to 50% CaO and MgO for nickel base super alloys; or (c) 100% CaF₂.

As shown in FIG. 3, adjacent to FIG. 1, a temperature chart illustrates the relative temperature of the molten flux bath, the molten metal bath, and the temperature at which the liquid-solid interface 5 occurs within the cooling ingot 7.

Referring now to FIG. 4, the crucible or melting vessel 22 is made of steel plate or copper plate comprising interface 22a and outerface 22b being welded to form an inner chamber 92 for cooling the vessel as by the employment of water. Annular helical baffles such as illustrated at 23 are for the purpose of circulating the water through the upper portion of the vessel. Support baffles 24 are indicated underneath the bottom of the vessel to direct the cooling fluid under different portions of this part of the vessel. Again helical baffles as indicated at 25 are employed in the mold section 28 for circulating the liquid through the inner chamber 93 to cool the mold as the metal is cast therethrough.

The dam 4 is in the form of an induction furnace which is circular and provided with induction coils 26 connected to the exterior of the vessel 22 through the lines indicated at 27. The principal difference between the mold as shown in FIG. 4 and that as shown in FIG. 1 is that the latter is square and the former is circular. The bore of the cooling casting mold 28 and the bore of the induction furnace 26 are in alignment having a common vertical axis. The furnace can be equipped with a central core member 29 as supported within the bore of the mold 28. The core member or mandrel 29 is water cooled as indicated by the coils 30 passing therethrough and externally tapered as indicated to allow for ingot contraction during cooling. The entrance 31a and discharge end 31b of the coils 30 are at the bottom of the core 29 and the bottom of the core is supported on a movable platform 100. Below the ingot extracting rolls 10 are a pair of movable guides 32 to control the operating position of the cutter bar members 33 actuated by the cylinders 34. In lieu of cutting bar members 33, a series of annularly positioned cutting torches around the ingot 35 may be utilized to perform the cutoff operation. When the tubular ingot 35 is lowered to a length sufficient for production use by its elevators 36, the movable guides 32 are moved inwardly to engage the tubular ingot 35 at which time the shearing members 33 are actuated to cut the ingot during that period of withdrawal where the temperature is still sufficiently hot to make it readily and easily workable as by the cutting operation of the shearing members or cutting torch. When the shearing members 33 are withdrawn, however, the upper guides 32a are employed to retain the tubular ingot above the severed ingot and the lower guides 32b are extended further to engage the core member 29 and hold the same while the severed ingot is stripped downwardly therefrom. The guides 32 and the cutting members 33 must of course be capable of movement in synchronism with the movement of the casting in order to be cooperative with the continuous casting process. In order that the severed ingot can be removed from the mandrel 29 while the casting process continues, the mandrel and water cooling leads 31a and 31b together with the mandrel support can be longitudinally aligned and positioned.

The power supply for the structure as shown in FIG. 4 is connected through the current regulator 37 which in turn supplies current to the controller 38 and thence current to the respective electrodes 15 and 16. The sensing device 18 supplies the proper signal to electronic controller 20 for controlling the regulator 37 as well as vibratory conveyor, feeding alloys and flux materials to the vessel. As shown, the electronic controller 20 is effective on the regulator 37 which controls the

voltage to the electrodes as well as the voltage to the feeders 12 and 13 and the ingot extractor rolls 10. The electrode feeder or regulating rolls 18 are controlled by the control depth or electrode submergence regulator 39 which is connected to drive the rolls 17 on one side and is connected to the grounded vessel 22 or casting mold section 28 to receive a thermal detection signal from the controller 37 according to the desired temperature level of the molten flux bath 11.

Thus, in FIG. 4 we have an offset feed arrangement with, if necessary, a water cooled grounded vessel and the heat of the metal being formed to cast the hollow ingot 35 is controlled not only by the electrode 15 but also by the high frequency induction furnace 26 and the cooling of the mold 35 as well as the mandrel 29. In this manner accurate control of the formation of the continuous hollow casting 35 may be obtained.

The hollow casting, of course, does not have to take the particular shape of a circular tube as illustrated in FIG. 4, but nevertheless a symmetrical casting is known to be more readily produced accurately. However, the castings of square, rectangular and hollow U-shaped members may be provided depending upon the actual use to which the product is to be eventually placed. Thus, the continuous casting by this process and structure may provide a closer tie-up between the end product use and the actual shape of the casting. This is one of the novel features of this invention, that is, alloys containing reactive elements can now be produced and cast into the desired shapes, which cannot be accomplished by the conventional continuous casting and investment casting processes.

FIG. 5 is an enlarged sectional view of the structure of FIG. 4 to show in greater detail, the insulating flux crust shell 101. The flux shell is formed on the surfaces of the interfaces 22a during the initial heat-up of the flux constituents prior to the feeding operation of the metal alloys to be refined and thereafter continuously cast. The flux crust shell 101 helps to protect the wall faces 22a and to act as an insulating medium to not only retain heat supply within the vessel but also to aid in heat transfer therein to enhance thermal uniformity in heat distribution within the vessel.

In the structure shown in FIG. 6, the annular cylindrical-shaped vessel 40 may or may not be a water cooled metal vessel but is provided with a refractory liner such as indicated at 41 for heat retention. An annular feeding area 2 is provided as shown with the casting area 3 intermediate thereof and surrounded by a coil induction furnace 26 which structure also provides the dam 4. This type of a vessel is readily adaptable for employment of three or more electrodes which may be powered by a three-phase circuit. These electrodes are indicated at 42, 43 and 44. The center electrode 43 can be aligned to be over the axial center of the casting area 3 and the casting throat 94. The continuous casting mold 49 can be formed in two parts, the upper part 45 and the lower part 46. Both of these parts 45 and 46 are water cooled as indicated at 102a and 102b. The lower casting mold 45 is movable away from the upper casting mold 46 such as illustrated in FIG. 7 wherein the ingot extractors 10 are supported in combination with the lower mold section 46 so as to be withdrawn below the same when the mold sections 45 and 46 are separated as illustrated in FIG. 7. The lower mold section 46 is supported by the elevators 47 which passes

through ingot clamp member 48 that supports the ingot 7.

The ingot clamp member 48 is supported from the withdrawing elevator member 50 and the elevator 47 for the lower mold portion 46 will by-pass the ingot clamp member 48 and the ingot 7 when the latter is dropped therebelow. When the ingot is sufficiently long, the elevator 47 is caused to withdraw the lower ingot mold section 46 as well as the ingot extractor rolls 10 to permit the ingot clamping members 51 to embrace the ingot 7 and provide a guide for the shear members 52 to be actuated by the reciprocating motors 53 for the purpose of cutting the ingot 7 just below that short portion of the ingot mold 45. As with the structure in FIG. 4, the temperature of the ingot at this time is sufficiently soft to permit a smooth slice and quick cut of the ingot, however, a circular saw or other similar device such as a cutting torch may be employed as mentioned in conjunction with the structure of FIG. 4. The cutting device and the clamps, of course, must be mobile to move downwardly as the ingot continues to move downwardly at the same velocity at which the ingot extractor rolls 10 would withdraw the same.

As soon as the ingot has been cut and withdrawn by the elevator 50, the lower half of the mold section 46 is moved upwardly to engage the stub of the ingot 7 and accept the same in its throat as shown in FIG. 6. The ingot extractor rolls 10 again continue to operate on the ingot as the ingot is being formed.

As shown in FIG. 8, the vessel or crucible 56 is an annular water cooled vessel being provided with a liner such as shown at 57 and is provided with nine electrodes being numbered A1, A2 and A3, B1, B2 and B3 and C1, C2 and C3. The B3 electrode is placed in the center of the vessel over the axial continuous casting throat 94. With this type of circular vessel, alloy material may be added annularly around the edge of the vessel as indicated by the positioning of each of the vibratory feeders 12. Lines connecting each of the nine electrodes are illustrated as being provided with the secondary coils 58 representing the secondary of the transformer winding of this multi-three-phase structure. Such a coil 58 is shown in the connecting line between A1 and A2, and between A2 and A3, and A3 and B1, and B1 and B2, and B2 and B3, which is the center electrode, then back in the line between B3 and C1, and in the line between C1 and C2, and in the line between C2 and C3, and in the line between C3 and A1.

If a DC electrode such as illustrated at 60 in FIG. 9 were placed in the center over the casting area 3, then the nine electrodes would be uniformly distributed around the perimeter of the circular vessel, as illustrated in that figure. Such an arrangement of electrodes may be employed even with the use of a high frequency induction furnace such as indicated at 26 at the throat of the continuous casting area 3 of FIG. 6.

As shown in FIG. 10, the three-phase system A1, A2, A3, which is different than the three-phase system B1, B2, B3 and the three-phase system C1, C2, C3, is employed so as to provide a progressive voltage movement around the circumference of the furnace which induces an electro-magnetic field in the manner of electromagnetic field produced in an alternator or an AC induction field. Thus, the voltage for the phase A1 leads an equal amount of the voltage for A2 and A3 and again the B phase is set up to produce a similar series of voltage progression, and likewise the C phase. After 360°,

the A phase again starts the same voltage cycle with relation to the voltage of its other phases. Since these three-phase currents are distributed through the flux in a circular manner, as described, their electromagnetic effect will have a tendency to rotate the molten flux bath as well as the molten metal and, at the same time, be withdrawn at the center of the casting area 3 continuously which will cause the melted moving and refined metal position to flow to the center and into the casting area 3 in the manner of a rotating vortex. Such a magnetic stirring action will produce refinement in the alloy which is conducive to an improved finished product. The use of DC current on the electrode 60 as shown at FIG. 9 would be independently controlled and in the manner of the use of the high frequency induction furnace 26 as illustrated in FIGS. 4 and 5.

A typical vessel installation would utilize nine 12-inch diameter peripheral electrodes with a 30,000 KVA transformer having several voltage taps ranging from 260 volts to 800 volts. The bottom and side walls can be lined with brick or graphite depending on the aggressiveness of the flux blanket. The vessel would be capable of 1500 to 2000 pounds per minute production rate.

Referring now to FIG. 11, it will be seen that the water cooled furnace 61 is offset and the feeding area again would be as indicated by the vibratory feeder 12 to the offset position or feeding area 2, and the water cooled casting throat over the casting area 3 will be provided with a form of ingot extractors such as indicated by the rollers 10.

The offset being sufficient to retain the solids, the molten metal flow is the only flow aside from a magnetic means for moving the pool which does not have sufficient velocity for moving the solids from within the feeding area 2. Here the electrodes 15 and 16 are supplied through the transformer 62 controlled by the current controller 63 which may be controlled by a sensing device such as illustrated in FIGS. 1 and 4. It is, of course, understood that such controls are employed in any of the vessels illustrated and described herein.

In the structure of FIG. 12, the water cooled vessel 65 is actuated by a two-phase system with current controllers and the common side of the dual phase is connected to the water cooled furnace itself.

In the structure shown in FIG. 13, the vessel 67 is water cooled and is provided with an upwardly sloping floor 68 in place of a dam 4. This is to illustrate that a dam can be formed not only by an abutment type dam as illustrated in previous figures, but also can comprise a slight gradual slope 64 because there is not a very swift movement within the molten bath 6 and any solid materials that find their way into the feeding area 2 are not apt to even pass over the gradual slope 64 to the casting area 3 which may permit better control of the interface of the casting mold because of the uniformity and the depth of the whole of the molten metal bath. Such a structure would be ideal for use in the circular furnace as shown in FIG. 6 with a high frequency induction furnace 26 surrounding the throat 94 of the casting area. In FIG. 13, the two electrodes 15 and 16 are connected to a three-phase supply circuit wherein the return of the opposite phases B and C is made directly through the water cooled vessel. As stated, the structure of these vessels of the water cooled type may readily be employed by using plates of steel, such as ¼ inch thick; however, they will also equally function

with higher efficiency when made of material such as copper which tests have shown that the plates can be $\frac{3}{8}$ to $\frac{1}{2}$ inch in thickness.

In the structures of FIGS. 11 to 13, inclusive, a sensing device such as indicated at 18 in FIG. 1 can be utilized for not only operating the withdrawing rollers 10 but also in controlling the voltage of the current controller for each of the different phase constructions in each of these figures. Thus, a uniform voltage control as well as a uniform temperature control may be maintained throughout the operation of the process.

In summary, the three possible power control systems shown in FIGS. 11 to 13 are controlled by the current controller which is manually set proportional to the metal feed. A feedback signal may be utilized from the thermal sensing device 18 near the flux surface to automatically control the current supplied to the electrodes. The balance of current input between the melting and casting sections or areas is controlled by the depth of electrode submergence. The power input in any one area can be decreased by positioning the electrode closer to the molten metal surface of the molten metal bath 6. The power (I^2R) is reduced because the current path through the flux is reduced and this can be determined by a reduction in voltage across the molten metal bath 6 and the electrodes 15 or 16. This voltage signal, therefore, is measurable from each electrode across the flux bath 11 and is proportional to the power input and can be used as reference signals for electrode positioning motors, such as in the case shown in the embodiment of FIG. 16, and aid to automatically balance the power input at any desired level. The two-phase and three-phase systems as shown in FIGS. 11 and 12, respectively, can have separate current controllers which can be used to automatically control power input using an electro-thermal sensing device 18 placed near the surface of the flux bath 11. The current controllers can be a saturable reactor, although not indicated in the embodiments of FIGS. 11 and 13. Additional heat can be supplied in connection with the casting area or the melting area for better heat control by employing induction coils, as exemplified in FIGS. 4 and 6.

Referring now to FIG. 14 wherein more graphic illustrations are employed to show different controls for actuating the electrodes as well as for withdrawing the ingot wherein a column such as illustrated at 71 and 72 and 73 provide a trackway for the vertical movement of their respective carriages 74 which in turn are guided by the supporting rollers 75. The carriages 74 on the columns or tracks 71 and 72 are provided with a clamp 76 to support the electrodes 15 and 16 and also function as the means for connection to the power supplies as indicated by the leads 77 and 78.

The carriage 74 for the column 72 supports the electrode 16 through its clamp 76 and is connected to the power source by the cable member 78. Each column also can contain a screw member 80 which is rotated by a suitable means such as the speed reducer 81 and which is coupled to and operated by the motors 82 for regulating the vertical position of the electrodes 15 and 16 which motors will, of course, be controlled by the proper control means necessary to change the position of the electrodes in the molten bath to regulate the voltage of the bath and thus the rate of melting and the rate of producing the molten metal. A block and pulley mechanism can also be used for regulating the vertical

position of the electrodes. The carriage 74 for supporting the continuously cast ingot 7 is provided with a clamp member 83 which is electrically operated. This carriage can also be provided with a screw jack 80 which is rotated through a speed reducing mechanism 81 operated by a suitable motor (not shown) that is likewise controlled commensurate with the other controls of the vessel in order to maintain the liquid-solid interface 5 of the ingot at the particular required zone of elevation in the throat as described above.

A support member 89 is arranged on the screw jack 84 and is electrically operated by the mechanism 85 to allow the ingot 7 to drop or be fed from the furnace at the particular rate for maintaining the interface 5 at the proper position in the casting area 3. Such controls as illustrated in the previous figure would be employed to actuate these motors in synchronism with the process and with each other.

The water cooled crucible or vessel 70 is supported on the centrally open platform 86 by means of the columns such as indicated at 79. These columns may or may not be connected with the columns that carry the carriages 74 for operating the ingots. In a structure of this character, it is obvious that the heat loss of the crucible owing to the water circulation as well as the radiation would account for approximately half of the heat required to maintain the flux molten. The water cooled mold will only be required in applications where the fluxes, such as CaF_2 base fluxes, will attack conventional insulating materials and dissolve the insulating brick thereby reducing its thickness.

Another and very important feature shown in FIG. 14 is the use of the flux overflow spout 87 which takes the upper portion of the flux from the molten flux bath on a continuous basis. This molten flux is carried off by the trough 88. The whole purpose for continuously discharging a portion of the flux is for the purpose of maintaining the flux with the desired constituents, some of which are quite volatile and very reactive when they are employed in combination with the impurities within the alloy charge. Thus the discharge of the flux may be continuously checked to determine whether or not the proper constituents are present in the molten flux. At the same time that the flux is discharged, an equal or equivalent amount of flux material is added by means of the vibratory flux feeders 13 as shown in FIGS. 1 and 2. The application flux overflow spout 87 is, of course, adaptable to every other type of structural showing of the crucible or alloy producing vessel.

The vessel or crucible 103 shown in FIG. 15 is very similar in structural features to the vessel 1 shown in FIG. 1 except that vessel 103 is liquid cooled and is provided with a different type of feed system wherein there is provided the hopper 104 having the removable lid 105 for receiving metal alloy material to be fed to the vessel 103. The vessel 103 is provided with a cover 106 through which is supported the electrodes 15 and 16 which are of the non-consumable type. The electrodes 15 and 16 are supported in the elastomer annular bushing 107 which is a high temperature elastomer which can withstand the extensive heat generated in the vessel 103. In this connection, the electrodes 15 and 16 are of the water cooled type.

The feed hopper 104 is provided with an outlet 108 to impose upon the interior chamber 110 of the hopper 104 a vacuum in order to draw off, as much as possible, the air environment from the metal feed. The lower

portion of the hopper 104 is provided with a rotary screw conveyor 101 which feeds the metal alloy material into the interior of the vessel 103. The rate of feed of the metal materials into the vessel 103 may be regulated by positioning of the hopper shuffle valve 112.

The vessel 103 is water cooled and is provided with appropriate inlets and outlets as shown for circulation of water as a coolant within its wall structure. The cover 106 is provided with a seal 113 around its perimeter to provide a substantially hermetically sealed chamber 114 within the vessel 103 above the flux blanket or bath 11. The same type of seal is employed at 115 in connection with the cover 105 for the hopper 104. The rotary screw conveyor 101 is supported by the antifriction bearing member 116 supported within the back wall of the hopper 104.

While a vacuum is being maintained within the hopper 104, an inert gas purge, such as argon, may be provided within the chamber 114 of the vessel 103. The inlet for the inert gas purge is shown at 117. Thus, the inert gas may enter at 117 and carry away from chamber 114 oxygen and other gases that have been removed by the molten flux blanket 11 from the molten metal bath. These gases can thereafter be carried away through outlet 118 or 108.

The structure of FIG. 15 in employing an inert gas purge, finds its best application in connection with those metal alloys which have an extremely high potential for solubility of oxygen. One example of such type of metal alloys in this group are the titanium alloys. Oxygen has a solubility in the flux blanket 11 and because of this can be transmitted to the alloy. In the case of titanium, the solubility of oxygen is very high and is an impurity detracting from the desired properties. For example, the inclusion of oxygen will make titanium hard and brittle. By using an inert atmosphere in chamber 114, one can keep the oxygen content level above the flux bath at a low level. However, there can be small parts of oxygen entrapped in part of the feed metal material from hopper 104 and therefore this is the reason why a vacuum environment is the most practical and feasible in hopper 104 since it would be more effective than the inert gas purge in inducing oxygen, entrapped in the metal feed, to separate and pull out of outlet 108.

In FIG. 15, the elevator 120 supports the ingot 7 formed having the support rod 121 supported within the seal 122 of the cover 123 of the casting mold section 124. Cover 123 is sealed to the casting mold section 124 by means of the perimetral seal 125. Here the extractor rollers 110 engage the elevator support rod 121 to aid in the withdrawal of the ingot being formed at the interface 5.

In FIG. 16, there is shown the crucible or vessel 126 which is identical in form and construction to those vessels shown in FIGS. 1 and 13. However, in FIG. 16 there is shown in more detail an improved positioning control for the electrodes 15 and 16 to provide the desired temperature gradient within the melting and casting area. By operation of the hydraulic servo gear motor 127 with respect to the drive rollers 17, the electrodes 15 and 16, which are of the nonconsumable type can be selectively positioned within the molten flux bath 11.

As is well known, the current to be supplied to electrodes 15 and 16 to produce a heat within the vessel 126 is a function of the electrical resistance of the molten flux bath 11. The electrodes 15 and 16 are indepen-

dently supplied by means of the transformers 128 and 130 from the current controllers connected to the two-phase power source 131. Thus, the arrangement shown is identical to the double-phase hook-up as shown in FIG. 12.

With the aid of the thermal sensor 18 together with the connection on the ground lines 132 to the monitor controllers 133, a signal can be obtained from line 134 indicative of the actual temperature within any desired area within the vessel 126 depending upon the location of the temperature sensor 18. This electrical signal is passed through the comparator 135 by means of the lead 134. This thermal related signal is thus compared with the actual voltage drop across the vessel 126 between lines 136 and 132 and depending whether or not the thermal sense signal is higher or lower than the desired voltage level across the vessel 126, the hydraulic control unit 137 will operate the hydraulic servo valve 138 which in turn will operate the hydraulic servo gear motor 127 in either a forward or reverse direction. In this manner, the penetration of the electrodes 15 and 16 into the molten flux bath 11 can be varied to obtain the desired heat level within the vessel 126. In this manner, the voltage reference across leads 136 and 132 represents the preset value of the power supply to electrodes 15 and 16. The voltage comparing signal from the monitoring controller 133 is proportional to the preset value of the controller relative as to the desired temperature within the molten flux bath 11. Thus, if the voltage comprising signal on line 134 is higher than the voltage reference signal, the comparator will send a signal to the hydraulic control unit to operate the servo valve 138 which in turn operates servo gear motor 127 to lower the corresponding electrode into the molten flux bath and thus reduce the temperature within the bath. Inhibitor means may be provided in the monitoring controller 133 to prevent the controller from working continuously in order to give the temperature within the vessel 126 sufficient time to obtain its value of the new temperature level caused by operation of the servo gear motor 127.

As shown in FIG. 16, the servo control valve 138 is provided with an input lead to supply hydraulic fluid to servo gear motor 127 by means of the pump P. The pump P is connected to the reservoir supply 140. The servo control valve 138 is provided with a return lead 141 to the reservoir 140 when the valve 138 is not being operated by the hydraulic control unit 137. Restriction check devices 142 are provided in the fluid supply lines 143 and 144 between the control valve 138 and the servo gear motor 127 to permit the gear motor 128 to operate in a limited finite manner.

FIG. 17 shows the temperature gradient through the vessel 126 and, in an accurate manner, shows the "slushy" layer actually formed at the liquid-solid interface 5. The graphic illustration of FIG. 17 shows an example of the melting point of a particular alloy and its relationship to this slushy layer. FIG. 17 also shows the difference of the temperature gradient through the vessel 126, that is, through the molten flux layer, the molten metal layer, the slushy layer 5 and ingot 7 wherein there is a low power input as indicated by the solid line and a high power input as indicated by the dotted line. It should be noted the higher thermal gradient across the slushy layer in connection with the higher power input. In this connection, it should be noted that the bigger the temperature differential across this zone

comprising the slushy layer, the more narrow in depth this zone will be which will result in a finer dispersion of the alloy content in the resulting ingot and provides a higher level of metallurgical properties particularly in connection with the micro-segregation of alloys in the ingot as well as improved grain structure aligned with the formed ingot.

I claim:

1. A unitary electroslog melting, refining and continuous casting vessel comprising

a metallurgy vessel having a melting and refining section and a casting section within said vessel said sections being in juxtaposed relation and separated by a dam projecting upwardly from the vessel floor,

a casting throat in the floor of said casting section to permit the continuous withdrawal of a cast ingot therefrom,

a molten bath of metallic constituents in said melting and refining section and a molten metal pool in said casting section, both said bath and said pool being blanketed by a common molten flux bath,

said bath and said pool being contiguous with one another and having their common surface essentially at the same level above the top of said dam,

electrode heating means to uniformly heat said bath and said pool and maintain a desired temperature level therein,

means for supplying metallic constituents to said refining section,

means for withdrawing said ingot as the same is cast, and

control means to control the operation of said supplying and withdrawing means to thereby maintain said common surface above the top of said dam.

2. The vessel of claim 1 characterized in that said electrode means is positioned for energizing and maintaining the application of heat to said molten flux bath, temperature sensor means positioned to thermally sense the temperature of said molten flux bath and produce a signal, control means operable to utilize said sensor signal to control the operation of said electrode means to maintain the proper temperature of said molten flux bath in both of said sections.

3. A unitary electroslog melting, refining and continuous casting vessel comprising a metallurgy vessel having a melting section and a casting section within said vessel, said casting section having a casting throat therein to continuously withdraw a cast ingot therefrom, a molten bath of metallic constituents in said melting section and a molten metal pool in said casting section, both said bath and said pool being blanketed by a common molten flux bath, means to add molten or solid metallic constituents directly to said molten bath, said bath and said pool being contiguous with one another and having their surfaces maintained essentially at the same level, said sections separated by a dam, electrode means for energizing and maintaining the application of heat to said molten flux bath, power supply means to aid said electrode means in producing a preselected temperature within said flux bath and consequential temperature gradient through said molten metal pool in said continuous casting throat, temperature sensor means positioned to thermally sense the temperature of said molten flux bath and produce a signal indicative of the temperature of said flux bath, comparator means to detect a difference between the

preselected value of temperature of said molten flux bath and said signal, and means responsive to said detected difference to adjust the position of said electrode means relative to said flux bath to maintain a temperature of said molten flux bath at said preselected temperature value.

4. The vessel of claim 1 characterized in that said electrode means having their ends adjustably suspended just within said molten flux bath in said vessel melting section and just within said casting section to electro-energize said molten flux bath.

5. The vessel of claim 4 characterized by consumable electrode means in said melting section and nonconsumable electrode means in said casting section.

6. The vessel of claim 4 characterized by regulatable current supply means to maintain the proper temperature of operation of said molten flux bath.

7. The vessel of claim 1 characterized in that said molten flux bath includes CaF_2 .

8. The vessel of claim 7 characterized in that said molten flux bath comprises a fluoride and one or more of the oxides of calcium, magnesium, aluminum, titanium and silicon.

9. The vessel of claim 1 characterized by an overflow spout adjacent the upper portion of said vessel to receive and continuously discharge a portion of said molten flux bath and means to replenish said flux constituents in said molten flux bath to maintain the desired level of constituents therein.

10. The vessel of claim 9 characterized by feeder means to supply alloy constituents to said melting and refining section, extracting means for controlling the withdrawal of said continuously cast ingot from said casting section, said circuit control means operable to actuate said feeder means and said extracting means commensurate with the desired thermal balance in the operation of said vessel.

11. The vessel of claim 10 characterized by gravimetric feeder means to supply said alloy constituents at a measured rate to said melting section commensurate with the rate of said ingot extraction and thermal balance in the operation of said vessel.

12. The vessel of claim 1 characterized by a core member positioned concentrically within said casting throat, cooling means within said core member to maintain the temperature at a predetermined temperature level, and means to extract said cast ingot from said casting throat thereby producing tubular types of ingots.

13. The vessel of claim 1 characterized by an annular dam in the floor of said vessel in said casting section and surrounding said casting throat.

14. The vessel of claim 16 characterized by an induction heating coil in said annular dam surrounding said casting throat.

15. The vessel of claim 1 characterized by a high frequency induction heating coil surrounding said casting throat.

16. The vessel of claim 1 characterized by a flux crust shell formed on the inner surface of said vessel.

17. The vessel of claim 1 characterized in that said vessel is annular with a centrally located casting section contiguous in concentric relation with an outer melting and refining section, said sections being separated by an annular dam with said casting throat in the floor of said casting section.

18. The annular vessel of claim 17 characterized by an annular induction heating coil in said annular dam surrounding said casting throat.

19. The annular vessel of claim 17 characterized by a high frequency induction heating coil surrounding said casting throat.

20. The annular vessel of claim 17 characterized by a plurality of feeder means positioned around said annular vessel to supply alloy constituents to said annular melting and refining section, extracting means for controlling the withdrawal of said continuously cast ingot from said casting section, said circuit control means to actuate said feeder means and said extracting means commensurate with the desired thermal balance in the operation of said vessel.

21. The annular vessel of claim 17 characterized in that said electrode means is uniformly distributed annularly just within said molten flux bath for energizing and maintaining the application of heat thereto, power supply means to aid said electrode means to produce a preselected temperature within said flux bath and consequential temperature gradient through said molten metal pool in said continuous casting throat, centrally located electrode means positioned over said casting section above said flux bath, said power supply means including a progressively connected three-phase multi-transformer system to produce a multi-phase alternating current supplied to said electrode means to induce an annularly directed electromagnetic field in said annular melting section.

22. The annular vessel of claim 21 characterized by consumable electrode means over said melting section and nonconsumable electrode means over said casting section.

23. The vessel of claim 1 characterized by a substantially hermetic sealing cover means on the top of said vessel and an inert gas purge maintained within said vessel above said flux bath.

24. The vessel of claim 23 characterized by feeder storage means to supply alloy constituents to said vessel, hermetic sealing means between said feeder storage means and said vessel and operative to permit the passage of said constituents from said feeder storage means into said vessel commensurate with the rate of continuous casting of said ingot, said feeder storage means maintained under a substantially maintained vacuum medium.

25. A unitary electroslag melting, refining and continuous casting vessel comprising

a metallurgy vessel having a melting and refining section and a casting section within said vessel said sections being in juxtaposed relation and separated by a dam projecting upwardly from the vessel floor,

a casting throat in the floor of said casting section to permit the continuous withdrawal of a cast ingot therefrom,

a molten bath of metallic constituents in said melting and refining section and a molten metal pool in said casting section, both said bath and said pool being blanketed by a common molten flux bath,

said bath and said pool being contiguous with one another and having their surfaces essentially at the same level,

electrode heating means to uniformly heat said bath and said pool,

means for supplying metallic constituents to said refining section,

means for withdrawing said ingot as the same is cast, and

circuit control means to sense the temperature level of said bath and pool in a manner

a. to control the application of said heating means to maintain said pool at a preselected temperature level and thereby maintain a liquid-solid interface in said casting throat below the top of said dam and

b. to control the rate of supplying of said constituents to the refining section cooperatively with the withdrawal of said cast ingot from said casting section,

c. said control means thereby continually maintaining the molten surfaces of said bath and said pool at a desired level within said vessel above the top of said dam to thereby impose a lateral resistance to the flow of unmelted metallic constituents from said melting section to said casting section.

26. A unitary electroslag melting, refining and continuous casting vessel comprising

a metallurgy annular vessel having an annular melting and refining section and a central casting section within said annular vessel

said sections being in concentric but contiguous relation and separated by an annular dam projecting upwardly from the vessel floor,

a casting throat in the floor of said casting section to permit the continuous withdrawal of a cast ingot therefrom,

a molten bath of metallic constituents in said melting and refining section and a molten metal pool in said casting section, both said bath and said pool being blanketed by a common molten flux bath,

said bath and said pool being contiguous with one another and having their surfaces essentially at the same level,

electrode heating means to uniformly heat said bath and said pool,

means for supplying metallic constituents to said refining section,

means for withdrawing said ingot as the same is cast, and

circuit control means to sense the temperature level of said bath and pool in a manner

a. to control the application of said heating means to maintain said pool at a preselected temperature level and thereby maintain a liquid-solid interface in said casting throat below the top of said annular dam and

b. to control the rate of supplying of said constituents to the refining section cooperatively with the withdrawal of said cast ingot from said casting section,

c. said control means thereby continually maintaining the molten surfaces of said bath and pool at a desired level within said vessel above the top of said dam to thereby impose a lateral resistance to the flow of unmelted metallic constituents from said melting section to said casting section.

27. The vessel of claim 3 characterized by inhibitor means included with said comparator means to prevent continuous operation of the latter upon adjustment of said electrode means by said responsive means to permit corrected adjustment of said temperature level to said preselected temperature value.

28. The vessel of claim 3 characterized by hydraulic control means included in said responsive means to control the operation of a servo motor means to correspondingly vary the penetration of said electrode means within said molten flux bath.

* * * * *