

[54] **VACUUM PROBE SURFACE SAMPLER**

[76] Inventors: **James C. Fletcher**, Administrator of the National Aeronautics and Space Administration with respect to an invention of; **Bruce A. Zahlava**, Cary, N.C.

[22] Filed: **Dec. 30, 1971**

[21] Appl. No.: **214,086**

[52] U.S. Cl. **73/421.5 R, 15/415, 73/28**

[51] Int. Cl. **G01n 1/00, G01n 1/24**

[58] Field of Search **73/421 R, 425.6, 73/28, 421.5 R; 15/415, 420; 55/270**

[56] **References Cited**

UNITED STATES PATENTS

2,128,200	8/1938	Allen	15/415 X
2,027,543	1/1936	Lofgren	15/420
3,422,679	1/1969	McGowan et al.	55/270 X
3,438,179	4/1969	Jouault	55/270 X

3,618,393	11/1971	Principe et al.	73/425.6 X
3,011,336	12/1961	Weiss	73/421 R X

Primary Examiner—Richard C. Queisser
Assistant Examiner—Daniel M. Yasich
Attorney—John R. Manning et al.

[57] **ABSTRACT**

A vacuum probe surface sampler for rapidly sampling relatively large surface areas which possess relatively light loading densities of micro-organisms, drug particles or the like. A vacuum head having a hollow handle connected to a suitable vacuum source is frictionally attached to a cone assembly terminating in a flared tip adapted to be passed over the surface to be sampled. A fine mesh screen carried by the vacuum head provides support for a membrane filter which collects the microorganisms or other particles with the head assembly being easily removed from the cone assembly without contacting the cone assembly with human hands.

6 Claims, 4 Drawing Figures

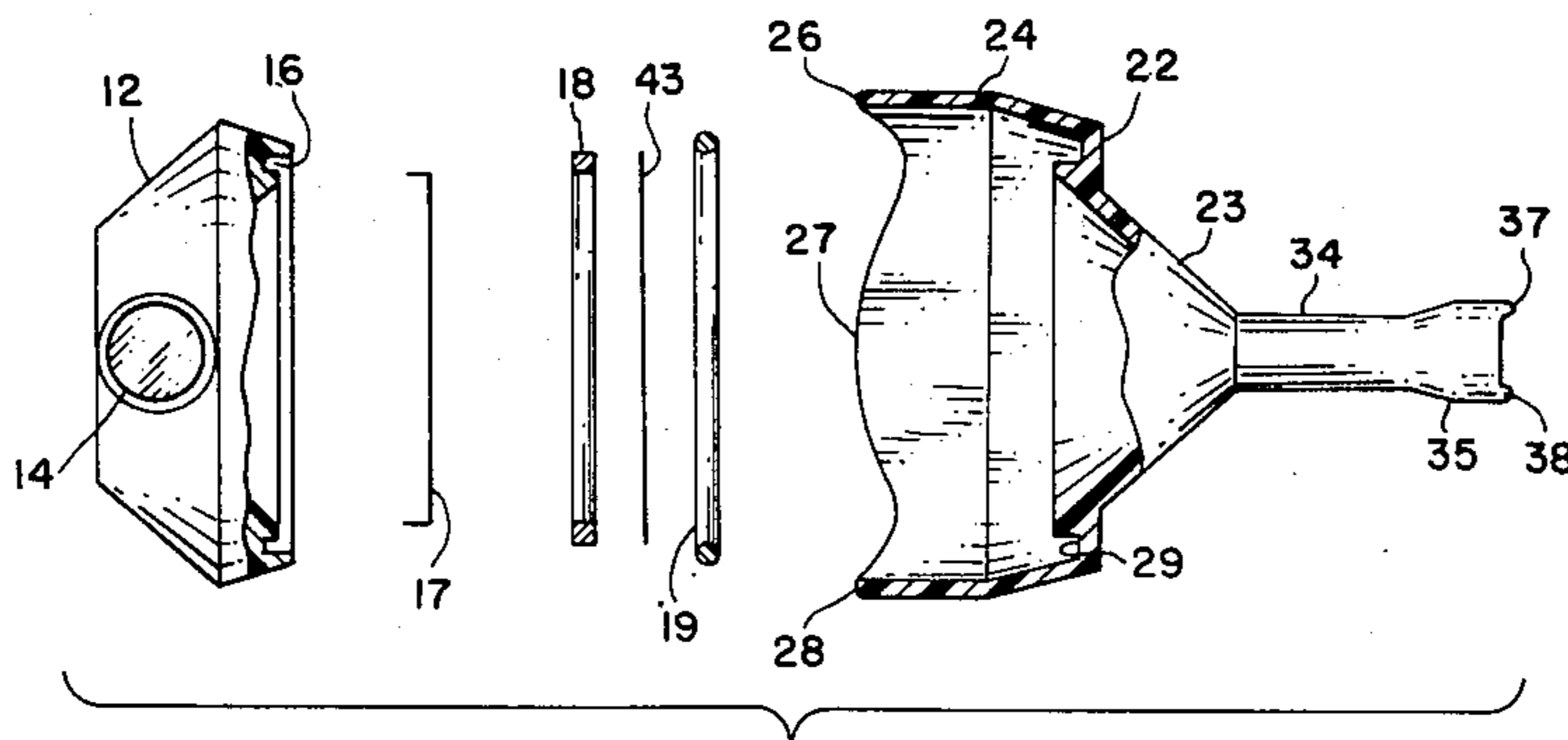

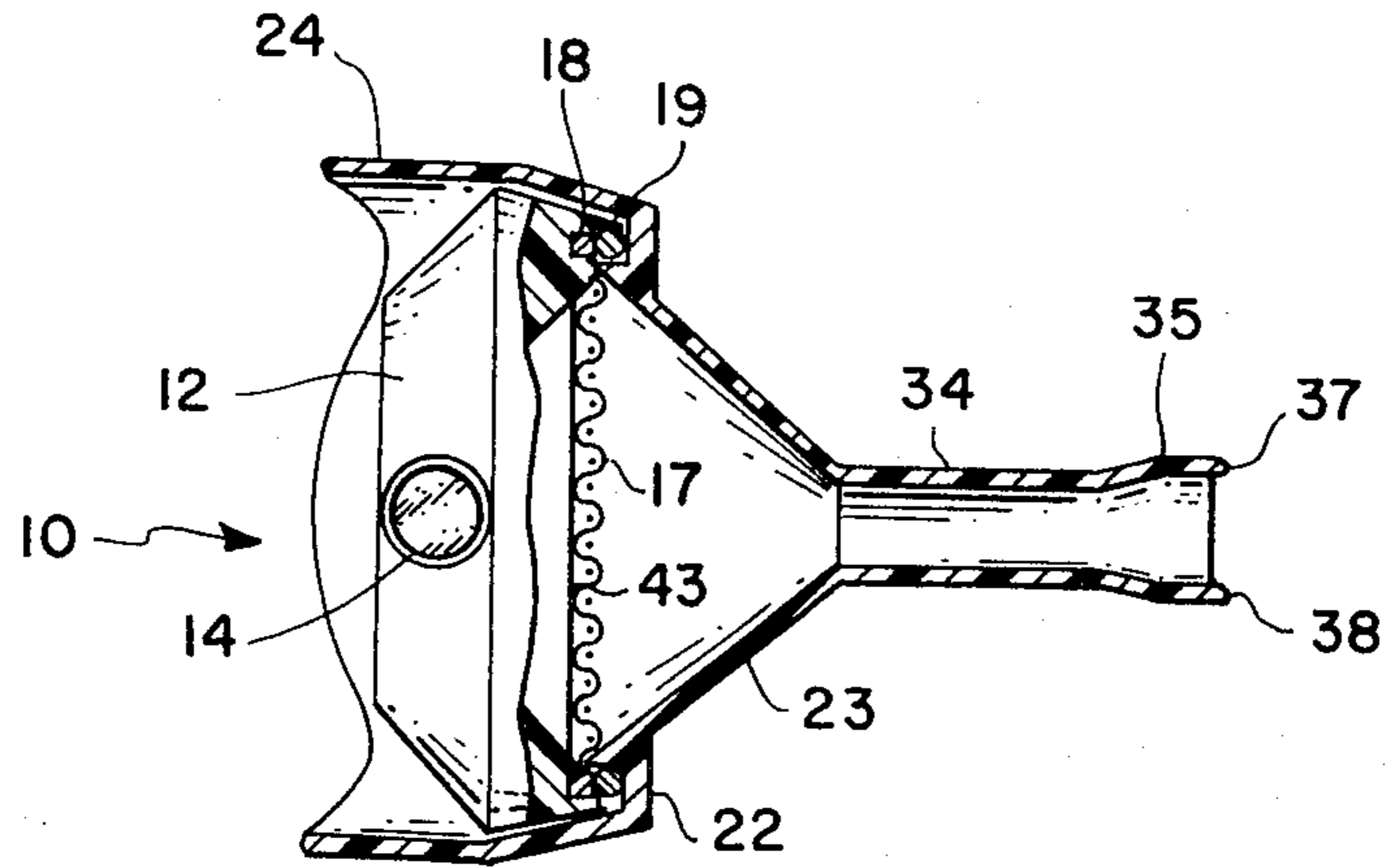

FIG. 1

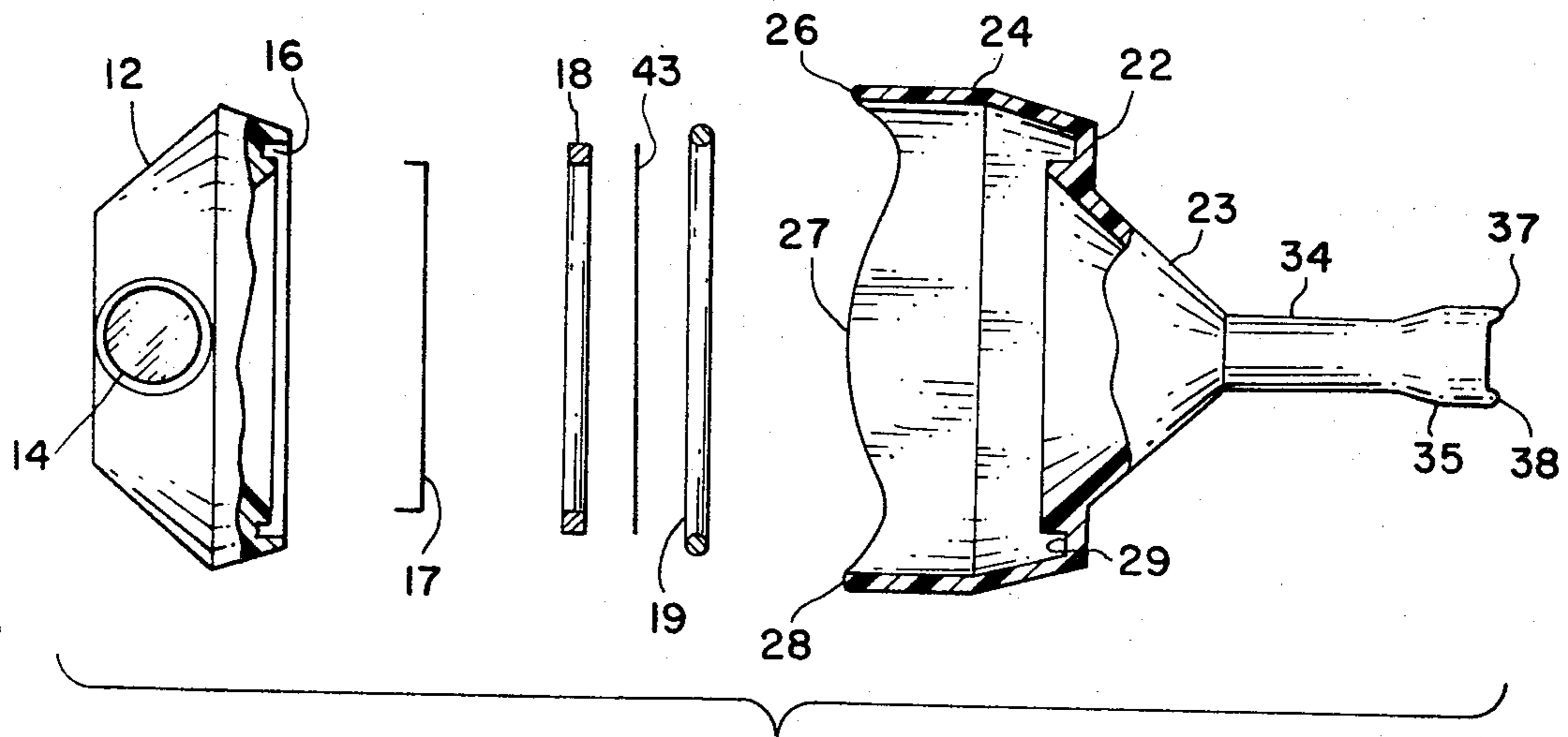

FIG. 2

INVENTOR.
BRUCE A. ZAHLAVA
BY *Howard J. Osborn*
Wallace Nelson
ATTORNEYS

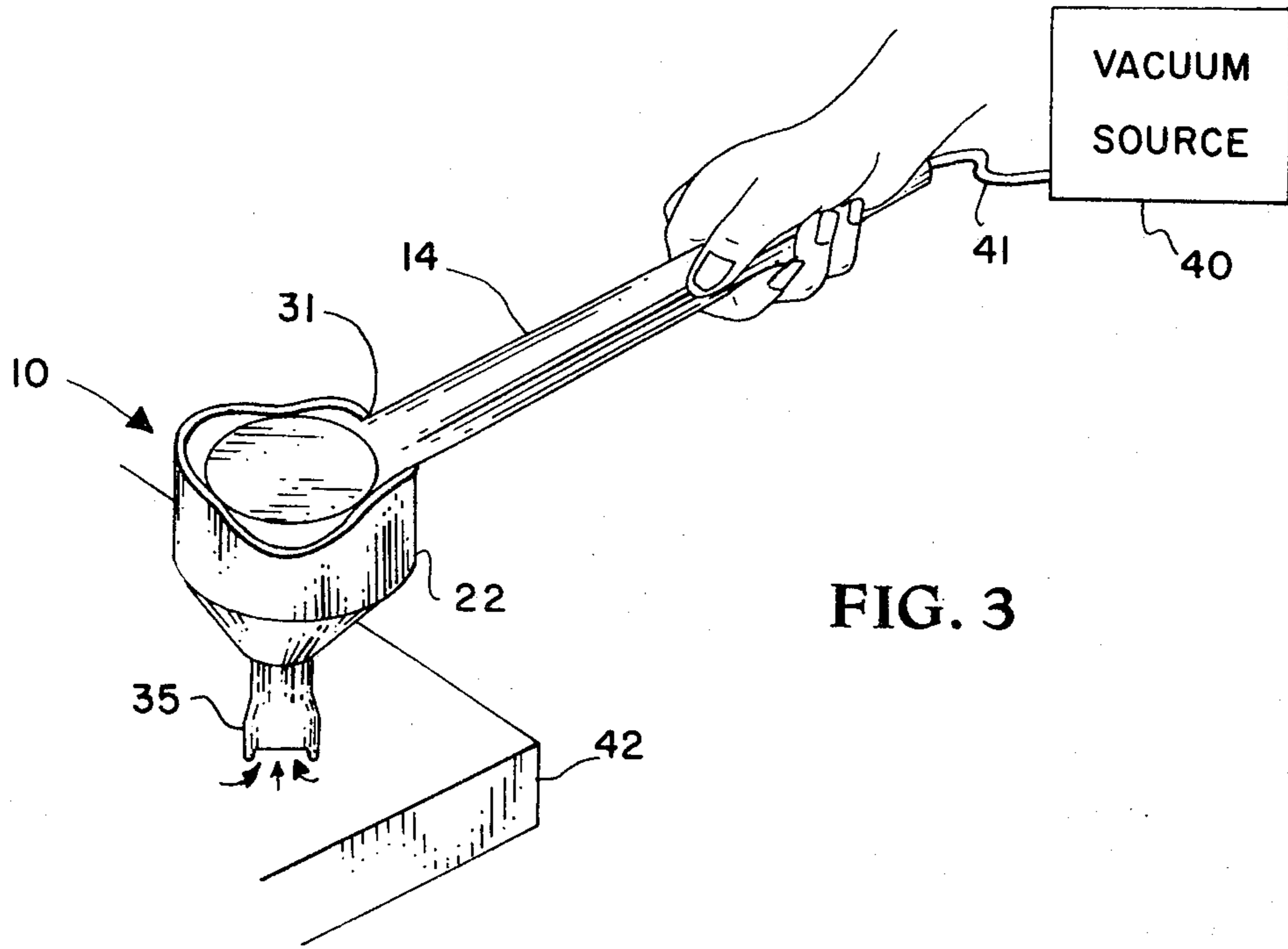

FIG. 3

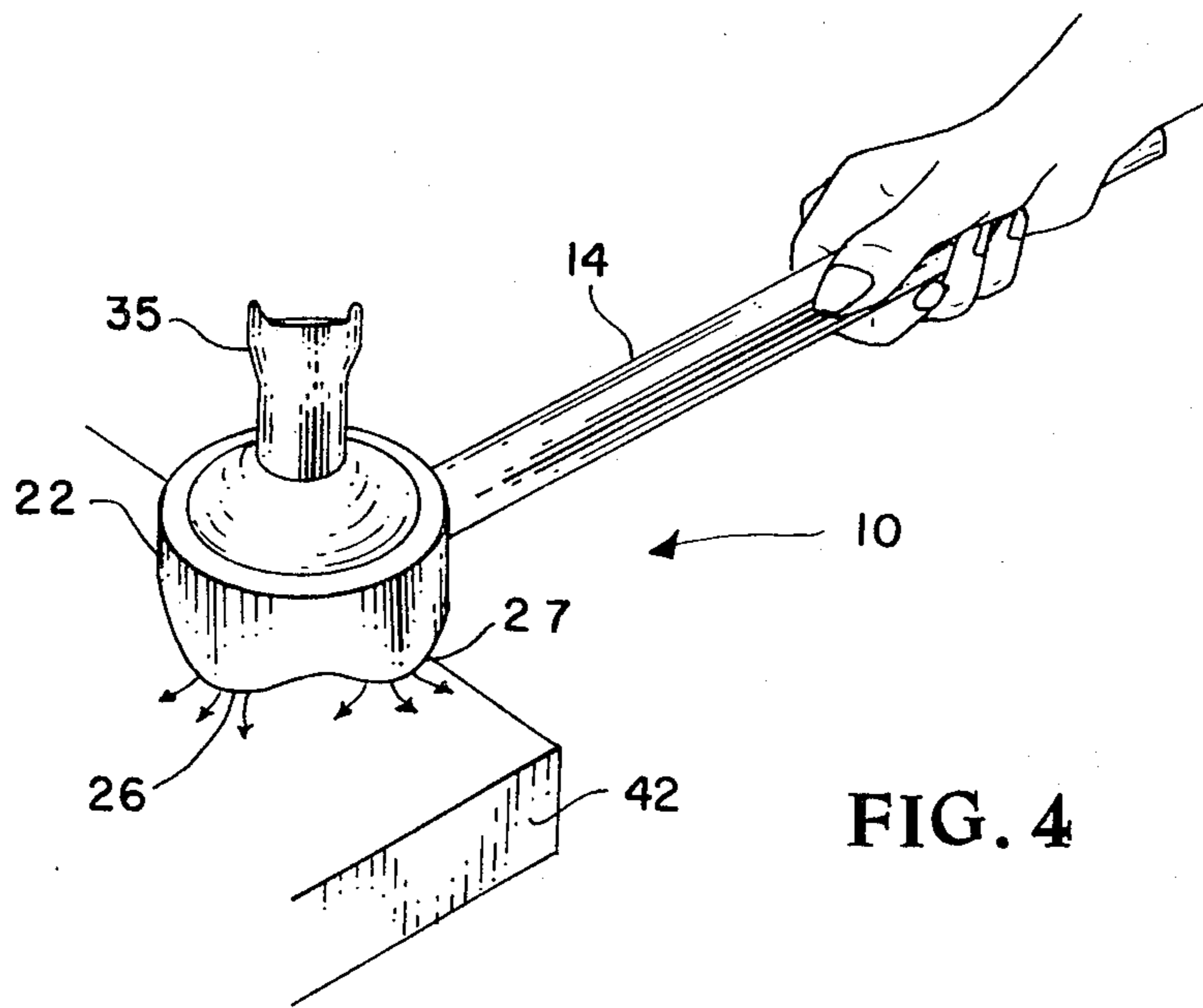

FIG. 4

INVENTOR.
BRUCE A. ZAHLAVA
BY *Howard J. Osborne*
Wallace J. Nelson
ATTORNEYS

VACUUM PROBE SURFACE SAMPLER

ORIGIN OF THE INVENTION

The invention described herein was made in the performance of work under a NASA contract and is subject to the provisions of Section 305 of the National Aeronautics and Space Act of 1958, Public Law 85-568 (72 Stat. 435; 42 USC 2457).

BACKGROUND OF THE INVENTION

This invention relates generally to a surface sampler and relates in particular to a vacuum probe surface sampler having the capabilities of rapidly sampling relatively light loading densities of micro-organisms, drug particles, or the like.

In the field of space exploration a definite need has arisen for a portable, lightweight, inexpensive sampling device to sample the surface of spacecraft returning from space missions for microorganisms or the like. Also there is a need for a sampling device of this type, by law-enforcement officers, to check large areas of auto seats, bed covers, clothing, etc., for illegal drug particles, and the like. To be effective for this type of sampletaking, the sampler device must be capable of sterilization prior to use and free from external contamination by contact with human hands prior to and subsequent to sampling of a suspect surface area.

It is therefore an object of the present invention to provide a new and novel portable, lightweight, inexpensive surface sampler device.

Another object of the present invention is a surface sampler that has the capabilities of sampling large surface areas which possess relatively light loading densities of micro-organisms, drug particles or the like.

A further object of the present invention is a surface sampler that can be operated by semi-skilled technicians and without danger of contaminating the test results by contact with human hands.

An additional object of the present invention is a vacuum probe surface sampler having separable sterilizable parts that may be readily assembled and disassembled without danger of contamination by human hands.

BRIEF SUMMARY OF THE INVENTION

According to the present invention, the foregoing and other objects are attained by providing a cup-shaped vacuum head assembly having an integrally attached tubular handle adapted to be grasped by an operator and attachable to a suitable vacuum source. A fine mesh screen is retained in the head assembly by a suitable split ring and the entire head assembly frictionally fitted into the open end of a cone assembly. An elongated spout extends from the cone assembly and terminates in a flared open tip for engaging the surface to be sampled. The open end of the cone assembly receiving the head assembly is in the form of a circular tripod with the tripod ends being spaced 120° apart.

DETAILED DESCRIPTION OF THE INVENTION

A more complete appreciation of the invention and many of the attendant advantages thereof will be readily appreciated as the same becomes better understood by reference to the following detailed description when considered in connection with the accompanying drawings wherein:

FIG. 1 is a part section view of the assembled vacuum probe surface sampler according to the present invention;

FIG. 2 is an exploded view of the vacuum probe surface sampler according to the present invention;

FIG. 3 is a view of the surface sampler of the present invention in operation; and

FIG. 4 is a view illustrating the disassembly of the surface sampler after completion of a sampling operation.

Referring now to the drawings, wherein like reference numerals designate identical parts throughout the several views, and more particularly to FIGS. 1 and 2, there is shown the vacuum probe surface sampler according to the present invention and designated generally by reference numeral 10. Surface sampler 10 is composed of two major parts, a head assembly 12 and a cone assembly 22.

Head assembly 12 is essentially cup-shaped and is provided with an integrally attached elongated tubular handle 14 as will be further explained hereinafter. The rim at the open end of assembly 12 is provided with a circumferential groove 16 for receiving a fine mesh screen 17. A split ring 18 serves to retain screen 17 within groove 16. Screen 17 may be formed of any conventional screening material with a 100-mesh, .010-inch thickness stainless steel screen as support for membrane filter 43 (FIG. 2) which is suitable for retaining most micro-organisms. Membrane filters of this type are commercially available in a wide range of mean flow pour sizes, from 75A (7.5m μ) to 5 μ . A specific example membrane suitable for use in the present invention is Triacetate Metricel, Type GA-6, having a pour size of 0.45 μ and a product of the Gelman Instrument Company, 600 S. Wagner Road, Ann Arbor, Michigan 48106. An O-ring seal 19 serves to insure a seal between vacuum head 12 and cone assembly 22.

Cone assembly 22 includes a hollow frusto-conical segment 23 having an integrally attached cup-shaped base portion 24 having a scalloped rim area forming a tripod with the scalloped tips being essentially 120° apart and designated by reference numerals 26, 27 and 28 (FIG. 2). A circumferential groove 29 is formed between conical segment 23 and the cup-shaped base 24 to receive O-ring 19 and, along with the tapered complementary surfaces of the mated parts, serves to provide frictional engagement of head assembly 12 by the cup-shaped base 24. A notched area 31 (FIG. 3) is also provided within cup-shaped base 24 to receive tubular handle 14 in such position that the entire head assembly 12 is vertically spaced from the scalloped surfaces 26, 27 and 28 when the surface sampler is assembled. An elongated tubular spout 34 also integrally extends from frusto-conical segment 23 and terminates in a substantially flattened open tip portion 35. A pair of short leg members 37 and 38 integrally extend from the opposite side of tip portion 35 to engage the surface area being sampled while maintaining the major portion of tip 35 slightly spaced from the surface.

OPERATION

The operation of the invention is now believed apparent. Initially, vacuum head assembly 12 is assembled with screen 17 being retained in place by split ring 18. O-ring seal 19 is then positioned within groove 29 and head assembly 12 and cone assembly 22 frictionally joined together. The entire cone assembly 22 is then sterilized in any conventional manner prior to use

thereof and can be packaged and maintained until ready for use. When using the surface sampler 10, tubular handle 14 is connected to a suitable vacuum source 40 via flexible tubing 41 (FIG. 3) and tip 35 moved over the surface to be sampled by movement of handle 14. The vacuum source 40 will insure a flow of air through tip 35 as noted by the arrows in FIG. 3 and any micro-organisms, drug particles or the like on the test surface flowing with the air and trapped by membrane filter 43. After completion of a sampling operation vacuum probe 10 is disconnected from vacuum source 40 and inverted as shown in FIG. 4. A slight tap to the protruding legs 26, 27 and 28 on a table 42, or the like, will release cone assembly 22 from head assembly 12, leaving filter 43 in cone assembly 22 for easy removal and subsequent analysis of the trapped particles.

Although the invention has been described relative to a specific embodiment thereof, it is not so limited, and many modifications and variations thereof will be readily apparent to those skilled in the art in the light of the above teachings. For example, no specific materials have been described for making the various components, it being understood that any suitable lightweight metal, plastics or the like, may be employed that would be inert to the material or harmless to the micro-organisms being sampled. The low cost of molding the cone assembly 22 from plastics permits discarding or disposing of the unit after use thereby resulting in significant economics over cleaning, inspection, repair, packaging and re-sterilization. Also, although a specific filter screen has been disclosed, it is to be understood that any conventional screen mesh size and screen material may be used with the present invention to provide support for membrane filter 43. Additionally, no specific vacuum pressure has been disclosed and any conventional vacuum system may be employed with the test that will cause an even steady flow of air through the sampler so that the micro-organisms or other particles tested will be trapped by the filter screen. It is therefore to be understood that within the scope of the appended claims the invention may be practiced otherwise than as specifically described.

What is claimed as new and desired to be secured by Letters Patent of the United States is:

- I. A vacuum probe surface sampler comprising:
 - I. a head assembly,
 - a. said head assembly being cup-shaped and including an integrally attached elongated tubular elongated tubular handle adapted to be grasped by an operator,
 1. said tubular handle being connected to a vacuum source for operation of said surface sampler,
 - II. a cone assembly detachably receiving said head assembly,
 - a. said cone assembly including a hollow frusto-conical segment having an integrally attached cup-shaped base portion and an elongated tubular spout,
 1. said cup-shaped base portion having a periphery thereof in the form of a tripod,
 2. said cup-shaped base portion also serving to receive said head assembly with a notched area

- in said cup-shaped base portion receiving said tubular handle in such position that when said head assembly is received by said cup-shaped base portion that the entire head assembly will be vertically spaced from the tripod periphery of said cup-shaped portion,
3. said tubular spout terminating in a substantially flattened open tip portion,
 4. a pair of leg members integral with said tip portion and adapted to engage the surface to be sampled by said surface sampler while maintaining the major portion of said tip portion slightly spaced from the surface and
 5. collecting means detachably mounted within said cone assembly serving to retain samples removed from the surface being sampled.
2. The vacuum surface probe sampler of claim 1 wherein said collecting means includes:
 - a 100-mesh stainless steel screen carried by said head assembly and supporting a membrane filter for collecting micro-organisms or the like when said vacuum probe surface sampler is passed over a test surface area.
 3. The vacuum probe surface sampler of claim 2 wherein:
 - said head portion is provided with an annular groove for receiving said screen and wherein the periphery of said screen is received by said annular groove.
 4. The vacuum probe surface sampler of claim 3 and further including a split retaining ring adapted to be received by said annular groove in said head assembly to thereby retain said screen in position within said head assembly.
 5. The vacuum probe surface sampler of claim 1 including an O-ring seal positionable between engaging surfaces of said head assembly and said cone assembly to provide a vacuum seal between these parts when friction-fitted together.
 6. A vacuum probe surface sampler comprising:
 - a. a head assembly, and
 - b. a cone assembly detachably receiving said head assembly,
 - said head assembly being hollow and including an integrally attached elongated tubular handle adapted to be grasped by an operator,
 - said tubular handle being attachable to a vacuum source at the free end thereof,
 - said cone assembly including an open cup-shaped portion and a base hollow cone portion integral with said cup-shaped portion,
 - said cone portion having an elongated tubular spout integrally extending therefrom,
 - said spout terminating in a flared substantially flattened open tip,
 - said flattened tip having an integrally attached pair of legs extending therefrom so as to maintain the major portion of said tip spaced slightly from a surface contacted by said legs during sampling of the surface for micro-organisms or the like, and
 - means detachably within said cone portion for collecting and retaining samples received from said surface being sampled.

* * * * *