

[54] **METHOD AND APPARATUS FOR BURNING COMBUSTIBLE LIQUIDS WITHIN A CONFINED BURNING AREA**

[72] Inventor: **Richard B. Heagler**, Salem Tsh., Westmoreland County, Pa.

[73] Assignee: **Pittsburgh Corning Corporation**, Pittsburgh, Pa.

[22] Filed: **Nov. 17, 1970**

[21] Appl. No.: **90,348**

[52] U.S. Cl. ....**431/2, 431/298, 431/7**

[51] Int. Cl. ....**F23d 21/00**

[58] Field of Search.....**431/2, 4, 7, 170, 298, 326, 431/331, 356; 110/7 R, 8 R, 8 A, 8 C**

[56] **References Cited**

**UNITED STATES PATENTS**

3,403,645	10/1968	Flowers, Jr.....	110/8 R X
3,556,698	1/1971	Tully .....	431/2
3,589,844	6/1971	Kraemer.....	431/2 X
2,246,346	6/1941	Carroll .....	431/298

*Primary Examiner*—Frederick L. Matteson  
*Assistant Examiner*—W. C. Anderson  
*Attorney*—Stanley J. Price, Jr.

[57] **ABSTRACT**

Oil residues and emulsions floating on a body of water are burned by confining the layer of residue within a furnace chamber. The furnace has combustion air inlet means adjacent the upper surface of the residue and a stack with inlets for a combustible gas. The combustible gas burns the combustible material in the gasses evolved from the combustion of the liquid residue to provide a relatively smokeless combustion process. The furnace is fabricated from a refractory material having insulating properties so that a substantial portion of the heat given off by the combustion of the residue is retained within the furnace to propogate further combustion of the residue and aid in the complete combustion of the difficult to burn portions of the residue. The furnace is preferably fabricated from a material that permits the furnace to float partially submerged in the body of water and may be easily transported from one location on the body of water to another location thereon. The furnace may be supported from suitable pilings and the residue conveyed directly into the furnace chamber. For certain types of difficult to burn residues, a layer of cellular glass nodules with a textured outer surface is positioned to float on the upper surface of the residue within the furnace chamber.

**13 Claims, 3 Drawing Figures**

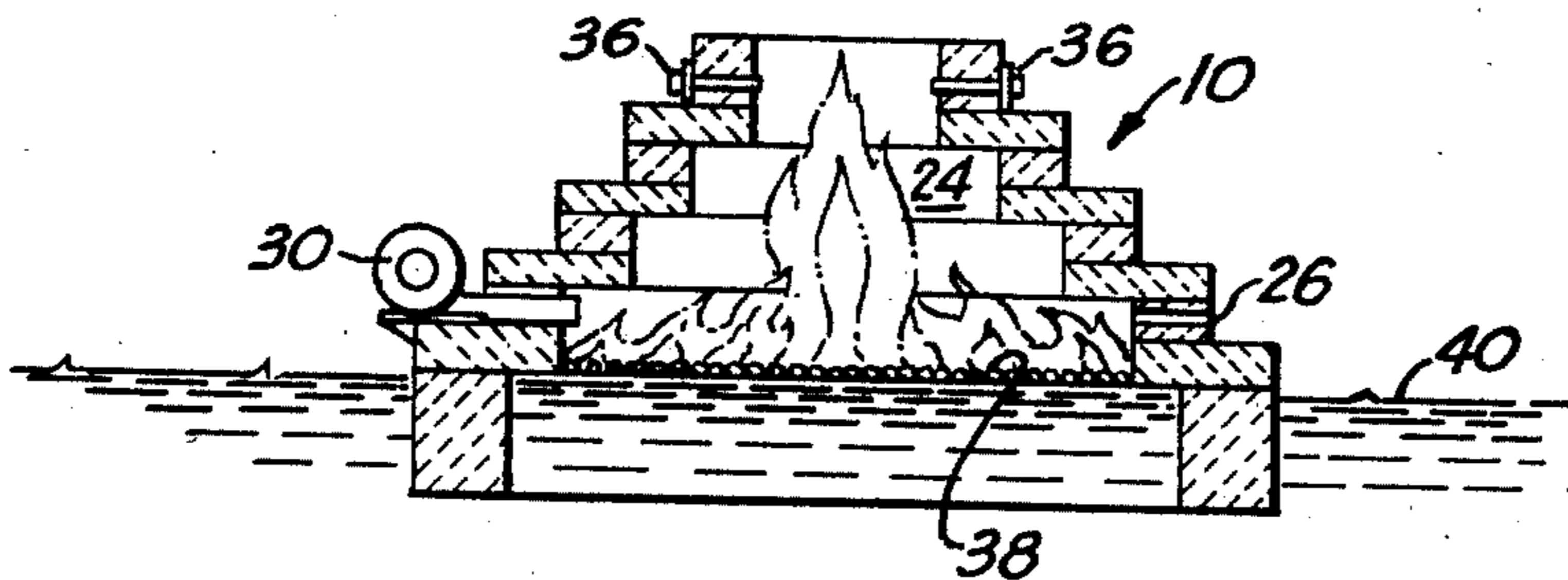

Fig. 1.

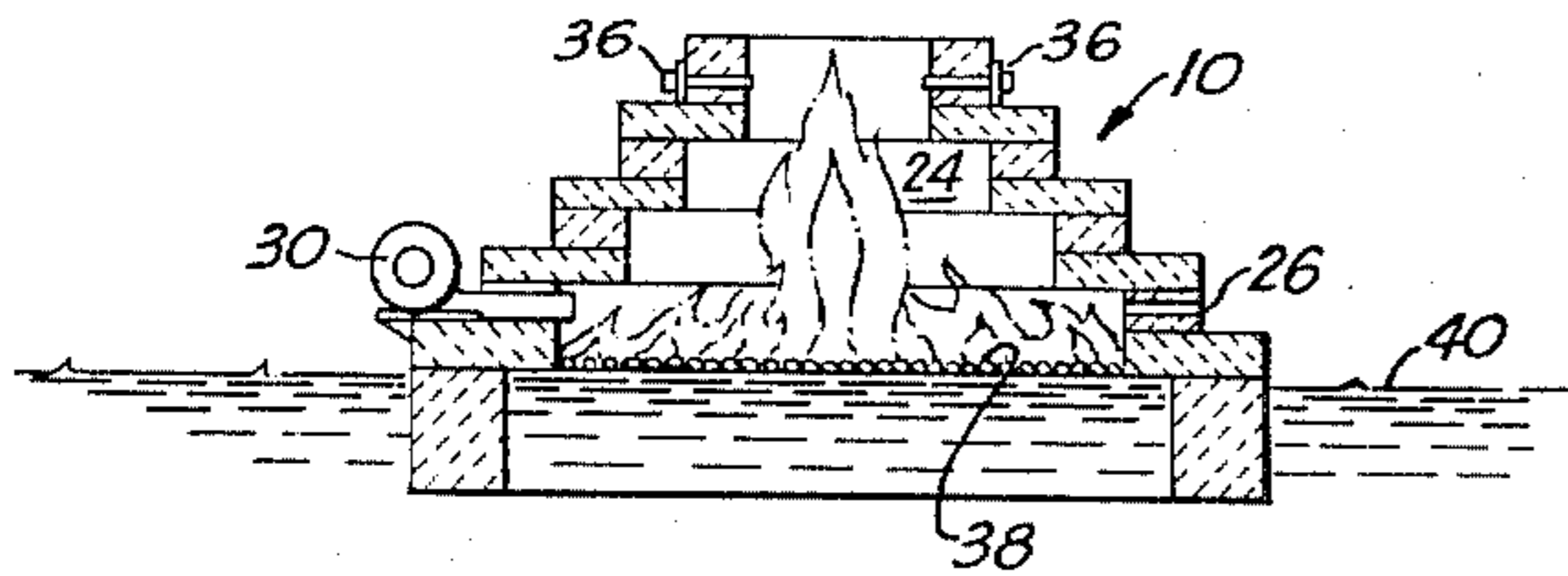
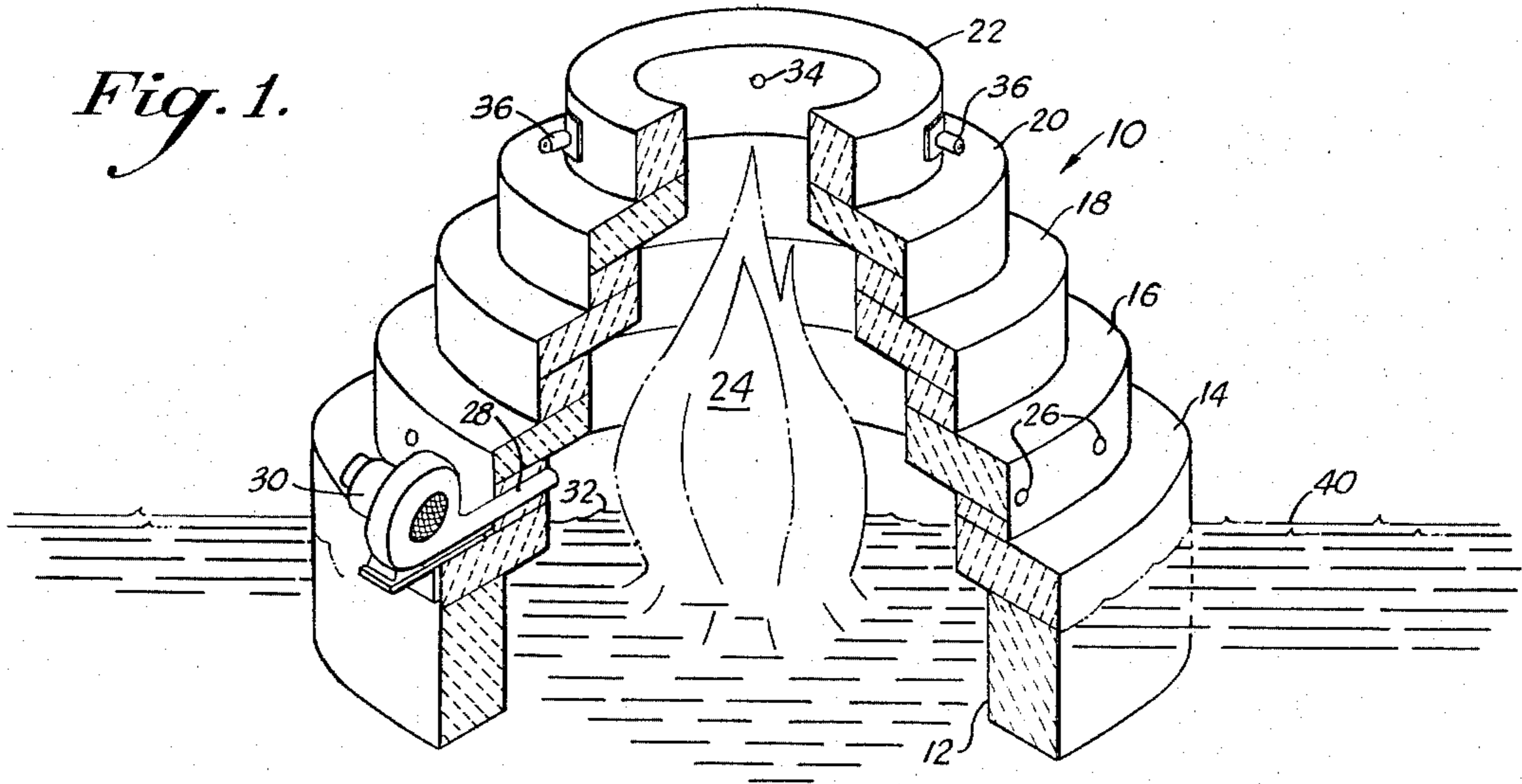

Fig. 2.

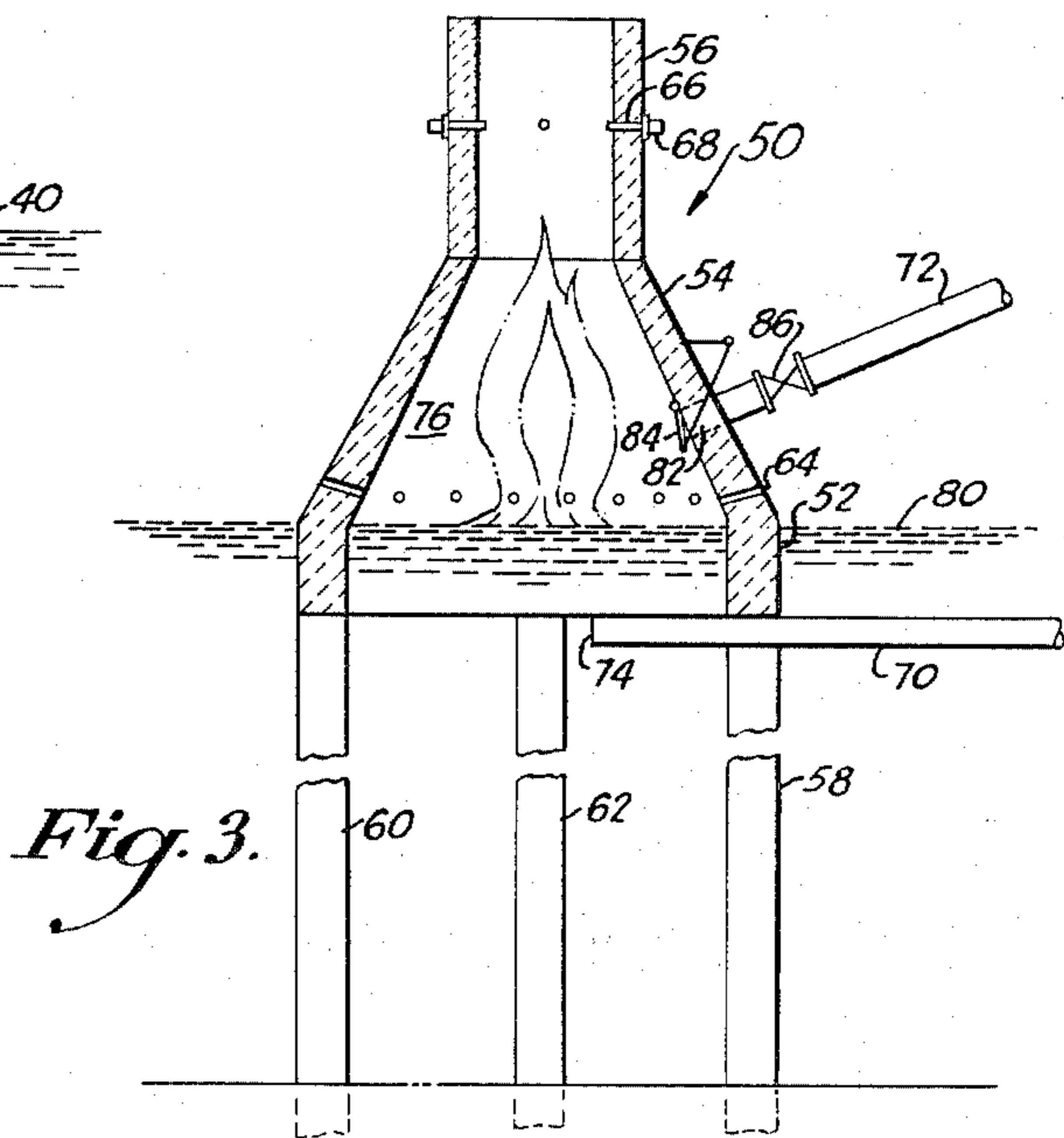

Fig. 3.

INVENTOR.

Richard B. Heagler.

BY *Stanley Stein*  
HIS ATTORNEY.



# METHOD AND APPARATUS FOR BURNING COMBUSTIBLE LIQUIDS WITHIN A CONFINED BURNING AREA

## BACKGROUND OF THE INVENTION

### 1. Field of the Invention

This invention relates to a method and apparatus for burning combustible liquids within a confined area and more particularly to a method and apparatus for substantially complete and relatively smokeless burning of difficult to burn combustible liquids within a furnace chamber.

### 2. Description of the Prior Art

In the recovery and refining of crude petroleum, difficult to burn fractions and emulsions are undesirable by-products. In the past, the emulsions have been collected in settling pits adjacent the wells where the water is separated from the crude oil. At predetermined intervals, highly combustible liquids are added to the settling pits and the lighter fractions of the crude oil in the emulsions are burned. The heavier, more difficult to burn fractions remain as an incombustible material within the settling pits. The heavy fractions frequently contain substantial amounts of inorganic material such as drilling clays and the like. During the combustion of the lighter fractions floating on the surface of the water in the settling pits, a substantial amount of dense, black smoke is generated. Because of the air pollution problem and the non-combustibility of the residue heavy fractions, other means and processes are being considered to dispose of the emulsions and difficult to burn residues.

## SUMMARY OF THE INVENTION

In the present invention, a method and apparatus is provided for the substantially complete and relatively smokefree burning of the combustible liquids within a furnace chamber. The furnace is fabricated from a refractory material having insulating properties to retain a substantial portion of the heat evolved during combustion within the furnace chamber. Combustion air inlet means are provided into the furnace chamber adjacent the upper surface of the residue. The furnace also includes apparatus for the combustion of combustible material in the gasses evolved from the combustion of the liquid residue. The furnace may be fabricated from a material that permits the furnace to float on a body of water and confine the combustion of the liquid residue to an area within the furnace chamber. For certain difficult to burn residues, a layer of cellular ceramic nodules are positioned to float on the upper surface of the residue within the furnace chamber. The cellular glass nodules preferably have a treated surface that improves the burning of the residues.

Accordingly, the principal object of this invention is to provide a method and apparatus for the substantially complete combustion of difficult to burn liquids in a confined area.

Another object of this invention is to provide a method and apparatus for burning difficult to burn combustible liquids without adding highly combustible diluents to maintain combustion of the difficult to burn combustible liquids.

These and other objects and advantages of this invention will be more completely disclosed and described in the following specification, the accompanying drawings and the appended claims.

## BRIEF DESCRIPTION OF THE DRAWINGS

FIG. 1 is a perspective view, partially in section, of one embodiment of the furnace floating on the surface of a body of water having a layer of difficult to burn combustible material floating thereon.

FIG. 2 is a view in vertical section of the furnace illustrated in FIG. 1 with a layer of cellular ceramic nodules floating on the upper surface of the difficult to burn combustible material.

FIG. 3 is a view in vertical section of another embodiment of the furnace wherein the furnace is suitably supported on pilings and the difficult to burn combustible liquid is fed to the furnace chamber through conduits.

## DESCRIPTION OF THE PREFERRED EMBODIMENTS

Throughout the specification, the term "cellular ceramic nodules with an outer treated surface" is intended to designate nodules prepared in accordance with the process described in U. S. Pat. No. 3,354,024 from a pulverulent glassy material and a cellululating agent or from other pulverulent materials as described in U. S. Pat. No. 3,441,396. A description of the process for treating the nodule surface by providing a textured surface may be found in U. S. Patent NO. 3,493,218. The cellular ceramic nodules enhance the combustion of the combustible liquid floating on the surface of the body of water in accordance with the process described in copending U. S. Pat. No. application Ser. No. 829,746, and copending U. S. Pat. application Ser. No. 38,868. Other processes to improve the combustion enhancing properties of cellular glass nodules are described in copending U. S. applications Ser. No. 38,866 and Ser. No. 38,865. The cellular ceramic nodules preferably have an apparent density of between about 6 and 30 pounds per cubic foot and a thermal conductivity of between about 0.40 and 0.50 Btu/hr./sq.ft./° F./in. at 75° F. For use as a combustion enhancing material, it is preferred that the nodules have a size of between 1/8 and 1/2 inch with an apparent density of between 10 and 20 pounds per cubic foot.

Referring to the drawings and particularly to FIGS. 1 and 2, there is illustrated one embodiment of the furnace generally designated by the numeral 10. The furnace 10 is preferably fabricated from a mixture of concrete and cellular glass nodules so that the furnace will float partially submerged in a body of water. The furnace 10 has a plurality of concentric rings 12, 14, 16, 18, 20 and 22 positioned in overlying relation with each other. The rings 12, 14, 16, 18, 20 and 22 are preferably fabricated from an admixture of nodules and Portland cement in a weight ratio of 5:1. A typical furnace having a total height of 25 inches, a bottom opening of 26 inches and a top opening of 10 inches, weighs approximately 130 pounds with an average wall thickness of 4 inches. Where desired, suitable reinforcing wires may be used on the lowermost rings. Also where desired, the top rings may be fabricated from an admixture of cellular glass nodules and asphalt as a binder.



When positioned on a body of water, the lower ring 12 and a portion of the adjacent ring 14 are submerged below the water level. For example, a furnace weighing approximately 130 pounds having the above discussed dimensions will have the lower rings submerged and the remainder of the furnace will be above the water level.

The intermediate ring 16 has a plurality of air passages 26 and an opening 28 is provided for the outlet of blower 30. Although the air passages 26 and opening 28 are illustrated as extending radially through the ring 16, it is preferred that the air passages 26 and opening 28 for blower 30 extend angularly to the radius to provide a circular motion for the air entering the chamber 24. With this arrangement, during combustion within the chamber 24, combustion air is drawn into the chamber 24 through the air passages 26 and, where it is desired, the blower 30 provides air under pressure through opening 28 to the furnace chamber 24 adjacent the top surface 32 of the liquid within the chamber 24. Suitable inlet openings 34 may also be provided in the top ring 22 for conduits 36 that are connected to a source of combustible gas such as methane, or the like. The openings 34 in the top ring 22 are arranged to provide for combustion of the combustible materials in the gasses evolved during the combustion of the liquid within the chamber 24 to provide relatively smoke-free combustion gasses.

As illustrated in FIG. 2, where the layer of combustible liquid is difficult to burn and where complete combustion of the combustible liquid is desired, a layer of cellular ceramic nodules 38 may be positioned in the chamber 24 to float on the upper surface of the combustible liquid and enhance the combustion of the combustible liquid in the manner noted in the above mentioned copending U. S. applications.

The furnace 10 is positioned on a body of water 40 to float thereon with a portion of the furnace submerged below the upper surface 32. The difficult to burn combustible liquid is lighter than water and floats on the upper surface 32. To ignite the combustible liquid, a small amount of a primer such as Varsol or other suitable low flash point igniting agent, is poured onto the surface 32 and is ignited by any suitable means. It should be understood that the furnace 10 could include an automatic or remotely controlled resistance type igniter or the like to ignite the liquid on the surface 32. After the combustible liquid is ignited combustion continues until substantially all of the combustible liquid within the confines of the chamber 24 floating on the surface of the water 40 is burned. Little, if any, residue remains. Since the furnace 10 is floating on the body of water 40, it may be easily moved or transported thereon by any suitable means to be positioned with a new inventory of the combustible material within the chamber 24.

The furnace 10 being fabricated from Portland cement and cellular glass nodules has refractory properties in that a minimum of spalling occurs within the furnace chamber during the combustion of the combustible liquid. Also, the nodule-concrete mixture provides insulating properties for the furnace 10 so that the heat generated during the combustion of the combustible liquid is retained within the chamber 24 and it is believed, contributes to the substantially complete combustion of the combustible liquid so that little, if any, residue remains on the surface of the body of water 40

within the chamber 24. With the furnace 10, it is now possible to confine the combustion to the circumferential area of the chamber 24 and to substantially and completely burn the combustible liquid floating on the surface of the body of water 40 with a generally smokeless flame. Although the configuration of the floating furnace 10 is generally described as circular, formed from a plurality of rings, it should be understood that the furnace may have other configurations, as, for example, rectangular or a poly-sided pyramidal shape.

Referring to FIG. 3, another embodiment of the furnace is illustrated and generally designated by the number 50. The furnace includes a base ring member 52 with an intermediate section 54 formed in the shape of a conical segment and an upper cylindrical stack section 56. The furnace 50 is preferably supported on a plurality of vertical posts or pilings 58. Air passages 64 are provided in the intermediate section 54 and, where desired, a blower similar to blower 30 may also be provided. The stack 56 has passages 66 for secondary combustion gas conduits 68.

There are illustrated a pair of combustible liquid supply conduits 70 and 72. The conduit 70 has an outlet opening 74 beneath the chamber 76 of furnace 50. The conduit 70 is located below the surface 78 below the body of water 80 and has an outlet opening 74 below the surface 78 and beneath the chamber 76. With this arrangement, combustible liquid flows out of conduit 70 through outlet opening 74 and floats upwardly in the body of water 80 to the surface 78 where it is ignited and burned, as previously discussed.

An alternate conduit 72 opens through the wall of the furnace intermediate portion 54 and has an outlet opening 82 through which the combustible liquid flows into the chamber 76. A suitable flap valve 84 is provided to close the outlet opening 82 during the combustion of the combustible liquid. A valve 86 is positioned in conduit 72 to control the flow of combustible liquid into the chamber 76.

The combustion of the combustible liquid within the chamber 76 is substantially the same as that previously described. The sections 52, 54 and 56 of furnace 50 may also be fabricated from cellular glass nodules and Portland cement to provide the desirable insulating and refractory properties. Other materials, however, may be employed. It is desirable, however, that the furnace have insulating properties to retain a substantial portion of the heat generated by the combustion gasses within the furnace chamber to contribute to the complete combustion of the combustible liquid.

The following examples are illustrative of the combustion of various difficult to burn combustible liquids floating on the surface of a body of water. A furnace similar to the furnace illustrated in FIGS. 1 and 2 was positioned to float on a body of water having a depth of approximately 2 feet and a diameter of approximately 10 feet.

#### EXAMPLE I

Two quarts of a residual oil from a settling pit in Wyoming that contained 20 percent by weight water and 10 percent by weight drilling clay was poured onto the surface of the water within the furnace chamber. A mono-layer of cellular ceramic nodules was positioned



on the oil-water surface within the furnace chamber. Approximately 100 cc. of a low flash point igniting agent (Varsol) was employed as a primer. The primer was ignited and the oil burned with little smoke forming during combustion. The combustion of the residual oil was complete with no residue remaining on the cellular ceramic nodules. The water within the chamber was clear, without any evidence of oil being present thereon.

#### EXAMPLE II

A similar test was performed with settling pit residue from Venice, Louisiana that contained about 55 percent by weight water and some drilling clays. The water formed an emulsion with the oil. Two quarts of this emulsion were poured onto the upper surface of the water within the furnace chamber. Again, cellular ceramic nodules were applied as a mono layer on the liquid surface within the furnace chamber. 100 c.c. of a low flash point primer was poured onto the liquid surface within the furnace chamber and ignited. The burn was relatively complete with very little smoke. The water within the chamber was clear. There was, however, a slight residue adhering to the cellular ceramic nodules.

#### EXAMPLE III

A residual oil from Louisiana, taken from a settling pit in which the residual had aged for a period of approximately 23 years and containing 40 percent Bentonite clay by weight and 15 percent water by weight, was burned in a similar manner within the furnace chamber. This residual material burned less readily than the material discussed in Examples I and II. Toward the end of the burn, an air blower injected air, under pressure, through one of the air passages and the burn increased in intensity. After the burn was completed, the water was clear and clean and the nodules were substantially free of residue.

#### EXAMPLE IV

Another burn was accomplished with the residual material set forth in Example III with the air blower on during the entire burn. An intense, hot flame was produced with little smoke throughout the burn. After the burn the water was clean and the nodules showed little or no residue adhering thereto.

#### EXAMPLE V

The material of Example III was burned under the same conditions as Example IV without a layer of cellular ceramic nodules on the surface of the liquid within the chamber. A larger amount of smoke was generated during the combustion as compared with Example III. After a period of time, combustion stopped and an inspection of the liquid surface within the chamber indicated oil remaining on the surface of the water. Additional low flash point primer was added and ignited and combustion continued for a relatively short period of time. The addition of primer was again repeated, however, upon completion of the burn, it was noted that oil remained on the surface of the liquid. Thereafter, a monolayer of cellular ceramic nodules was placed on the liquid surface within the chamber and a low flash

point primer added. The oil ignited and little or no smoke was present. After combustion was completed, the water was clear, without evidence of oil.

#### EXAMPLE VI

The burning procedure described in Example I was repeated with a Mississippi-Louisiana crude oil having an A.P.I. gravity of 39.0 - 40.5, a sulfur content of between 0.2 percent and 1 percent and an asphalt content of between 5 and 6 percent. The flash point was indicated as ambient. The burn was complete with no residue remaining on the surface of the liquid within the furnace chamber.

#### EXAMPLE VII

The burning procedure described in Example I was repeated with Bunker C oil having a flash point of 200° F. and an A.P.I. gravity of between 13 and 15. The sulfur content was 6 percent and the asphalt content was between 55-60 percent. The burn was complete without any oil residue remaining on the surface of the water.

In order to further reduce the smoke, the cellular ceramic nodules were sprayed with a 10 percent solution of barium petrasol, a smoke reducing agent used in Diesel fuels. The addition of the barium petrasol further reduced the smoke generated during combustion.

Although cellular ceramic nodules enhance the combustion of the above difficult to burn combustible materials, it is possible, without nodules, to burn relatively difficult to burn combustible materials, although not completely, in the previously described furnace chambers on a body of water and to isolate the combustion area.

According to the provisions of the patent statutes, I have explained the principle, preferred construction and mode of operation of my invention and have illustrated and described what I now consider to represent its best embodiments. However, I desire to have it understood that, within the scope of the appended claims, the invention may be practiced otherwise than as specifically illustrated and described.

I claim:

1. Process for burning a combustible liquid within a confined area comprising,
  - confining a combustible liquid within a furnace chamber,
  - positioning a layer of cellular ceramic nodules on said combustible liquid surface,
  - supplying combustion air to said chamber at a location adjacent to the upper surface of said combustible liquid,
  - igniting said combustible liquid on the surface of said cellular ceramic nodules,
  - retaining a substantial portion of the heat generated by the combustion of said combustible liquid within said chamber to propagate the further combustion of said combustible liquid,
  - withdrawing the gasses of combustion from said chamber through a stack outlet opening above the top surface of said liquid, and
  - burning substantially all of said combustible liquid in said chamber.

2. A process for burning a combustible liquid within a confined area as set forth in claim 1 which includes,



- adding a primer liquid having a flash point substantially lower than said combustible liquid to a portion of said combustible liquid surface within said chamber,
- igniting said primer liquid and said combustible liquid within said chamber. 5
- 3. A process for burning a combustible liquid within a confined area as set forth in claim 1 which includes, supplying a combustion gas to said chamber adjacent said stack outlet opening, 10
- burning combustible material in said combustion gas adjacent said stack outlet opening and withdrawing substantially smoke-free gases from said combustion chamber through said stack outlet.
- 4. A process for burning a combustible liquid within a confined area as set forth in claim 1 which includes, supplying combustion air under pressure to said chamber at a location adjacent to the upper surface of said combustible liquid, and 15
- withdrawing substantially smoke-free gases of combustion from said chamber through said stack outlet. 20
- 5. A process for burning a combustible liquid within a confined area as set forth in claim 4 in which, said combustible liquid comprises an oil-water emulsion containing up to 55 percent water by weight. 25
- 6. A process for burning a combustible liquid within a confined area as set forth in claim 4 in which, said combustible liquid contains up to 40 percent by weight pulverulent clay products. 30
- 7. A process for burning a combustible liquid within a confined area as set forth in claim 1 in which, said combustible liquid floats as a layer on the upper surface of a body of water.
- 8. A process for burning a combustible liquid within a confined area as set forth in claim 7 in which, said furnace chamber has a bottom opening, and positioning said furnace chamber with said bottom opening below said layer of combustible liquid to isolate a portion of said combustible liquid layer within said chamber. 35 40
- 9. A process for burning a combustible liquid within

- a confined area as set forth in claim 8 which includes, floating said furnace on said body of water with said chamber opening below said layer of combustible liquid to isolate a portion of said layer of combustible liquid within said chamber.
- 10. A process for burning a combustible liquid within a confined area as set forth in claim 8 which includes, feeding combustible liquid to said chamber through a conduit having an opening below said layer of combustible liquid and in said body of water and below said chamber bottom opening.
- 11. Apparatus for burning a combustible liquid within a confined area comprising, 5
- a furnace having a chamber with a bottom opening and a top outlet opening,
- said furnace having walls of a refractory insulating material to retain substantial portion of the heat generated by the combustion of said combustible liquid within said chamber to further propagate combustion of said combustible liquid within said chamber,
- air inlet openings in said furnace walls adjacent said bottom opening, and 10
- said furnace being formed from a relatively light material so that said furnace floats partially submerged on a body of water with said bottom opening below the upper surface of said body of water and said air inlet openings above said upper surface of said body of water.
- 12. Apparatus for burning a combustible liquid within a confined area as set forth in claim 11 which includes, 15
- means to supply air under pressure through said side walls into said chamber.
- 13. Apparatus for burning a combustible liquid within a confined area as set forth in claim 12 which includes, 20
- means to supply combustion gas adjacent to said outlet opening to burn combustible material in the combustion gases evolved while burning said combustible liquid. 25

\* \* \* \* \*

45

50

55

60

65