

[54] **PARCEL SORTING CONVEYOR SYSTEM**

[72] Inventor: Donald C. Muller, Whittier, Calif.
[73] Assignee: Butz Engineering Corporation, Azusa, Calif.
[22] Filed: Oct. 12, 1970
[21] Appl. No.: 79,928

[52] U.S. Cl. 198/155, 198/38
[51] Int. Cl. B65g 17/18
[58] Field of Search 198/38, 155; 214/11 R, 11 AST

[56] **References Cited**

UNITED STATES PATENTS

3,231,066	1/1966	Harrison	198/155
3,167,192	1/1965	Harrison	198/155 X

Primary Examiner—Edward A. Sroka
Attorney—Huebner & Worrel

[57] **ABSTRACT**

An endless parcel sorting conveyor system embodying a plurality of contiguous parcel receiving receptacles movable through a predetermined orbit. Deflecting means associated with each of said parcel receiving receptacles including track elements. Said deflecting means is activatable upon command to tilt said receptacles from a normal parcel receiving position to the right or left of the line of travel in said orbit discharging by gravity parcels thereon at predetermined positions. The parcel sorting conveyor system also includes reset deflector means selectively positioned therealong adapted to return said parcel receiving receptacles to said normal parcel receiving position.

14 Claims, 39 Drawing Figures

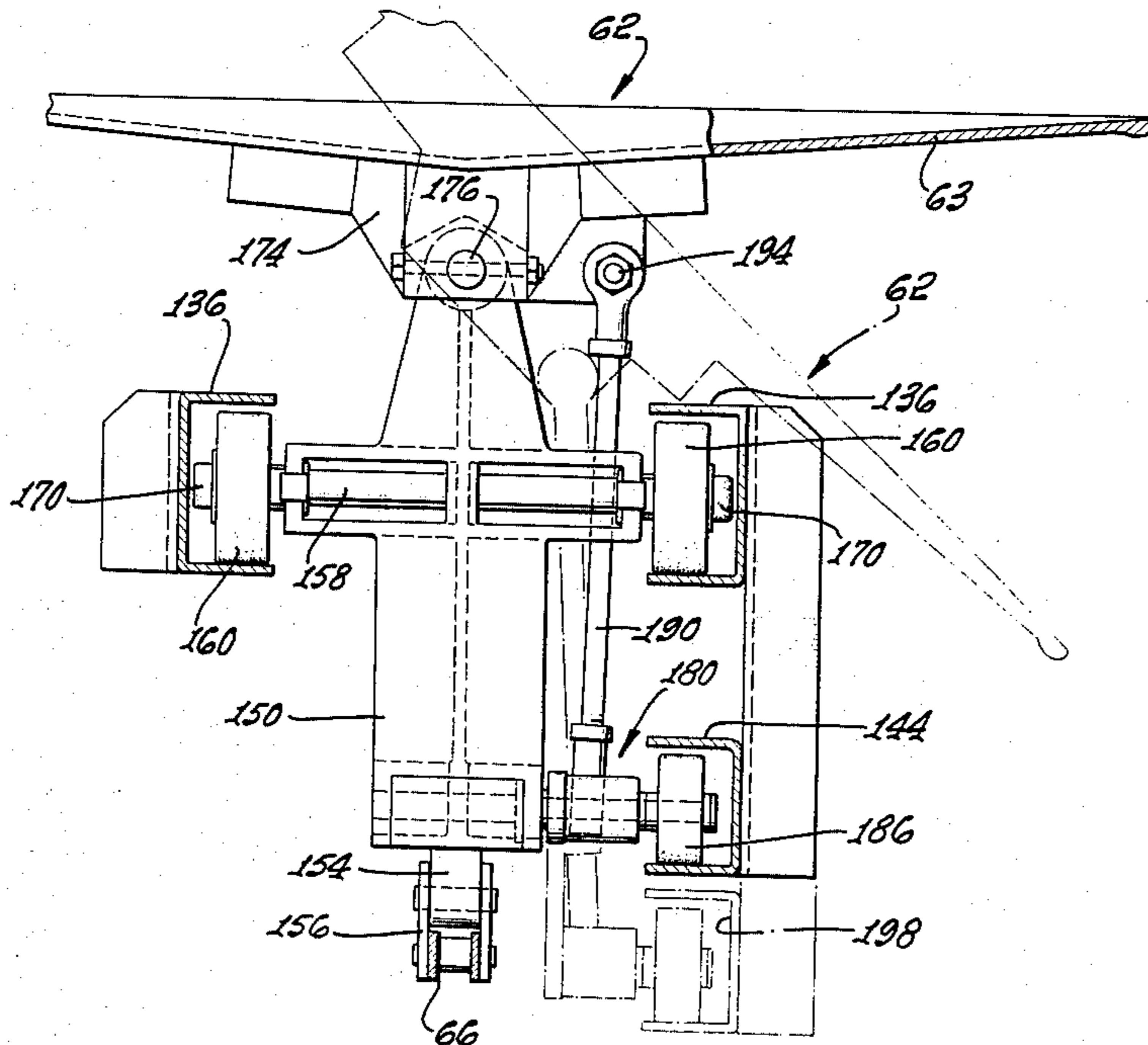

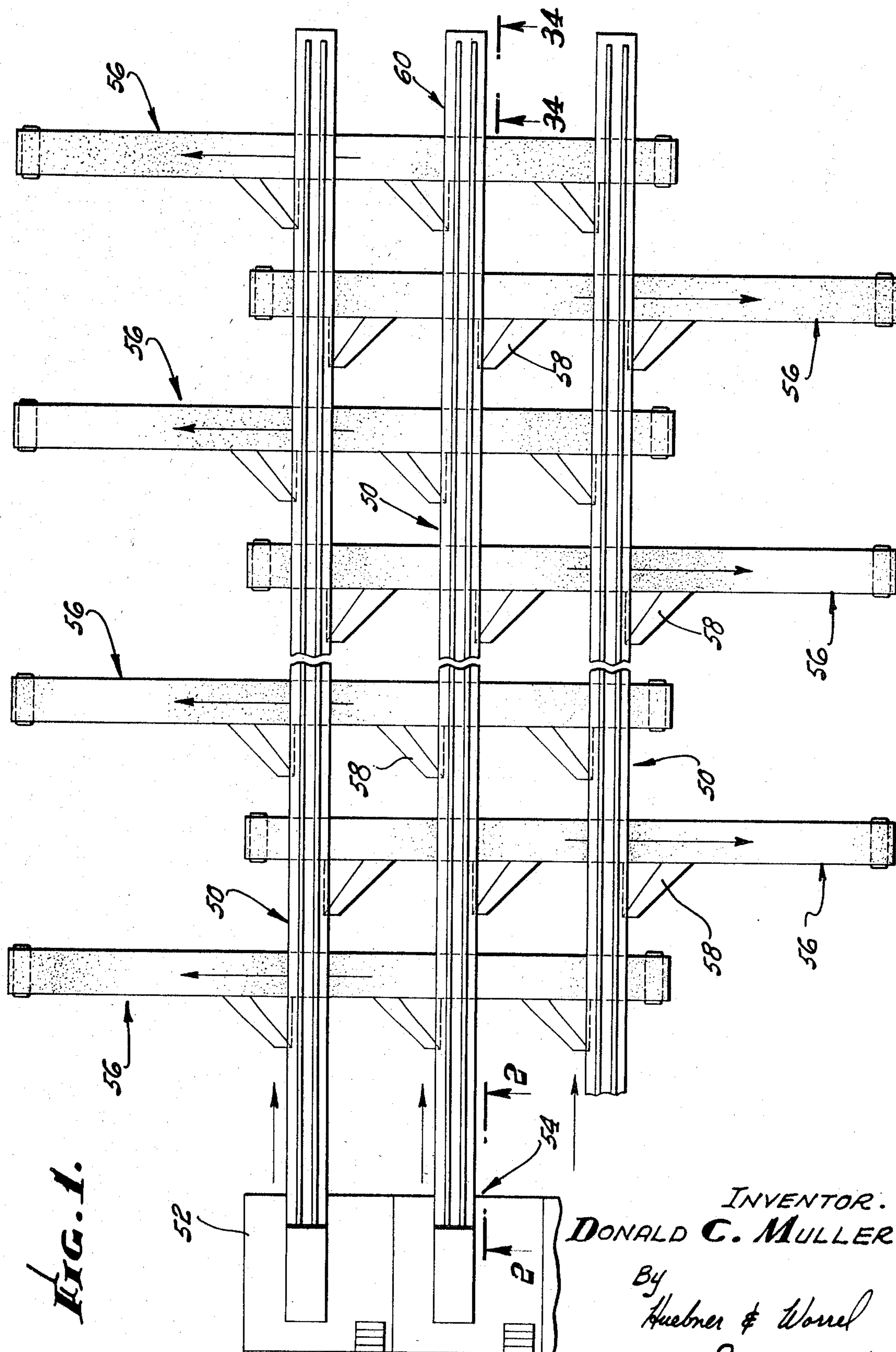
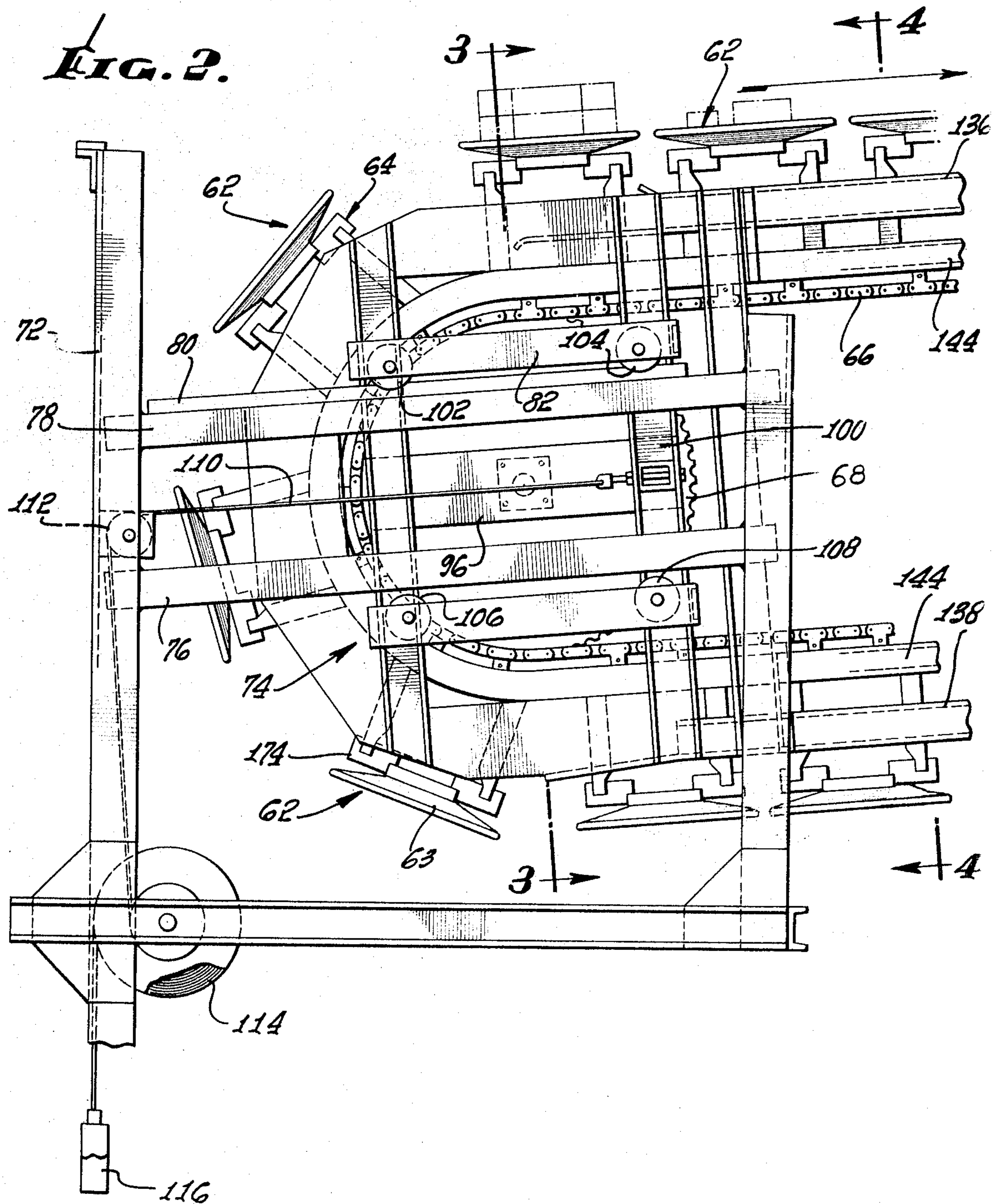

FIG. 1.

INVENTOR.
DONALD C. MULLER

By
Huebner & Wornel
ATTORNEYS.



INVENTOR.
DONALD C. MULLER

By
Huebner & Ward
ATTORNEYS.

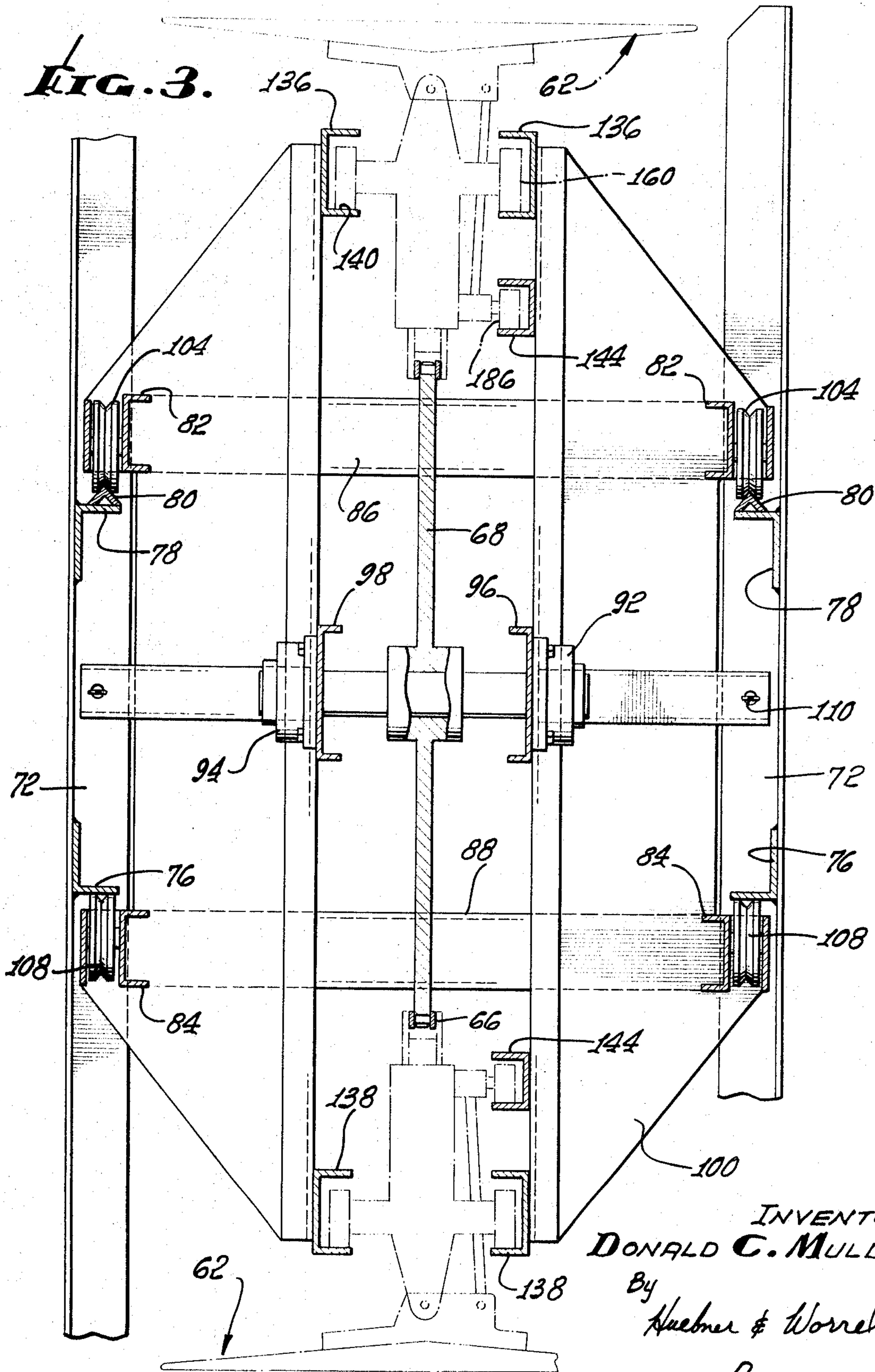

INVENTOR.
DONALD C. MULLER
By
Huebner & Worrel
ATTORNEYS.

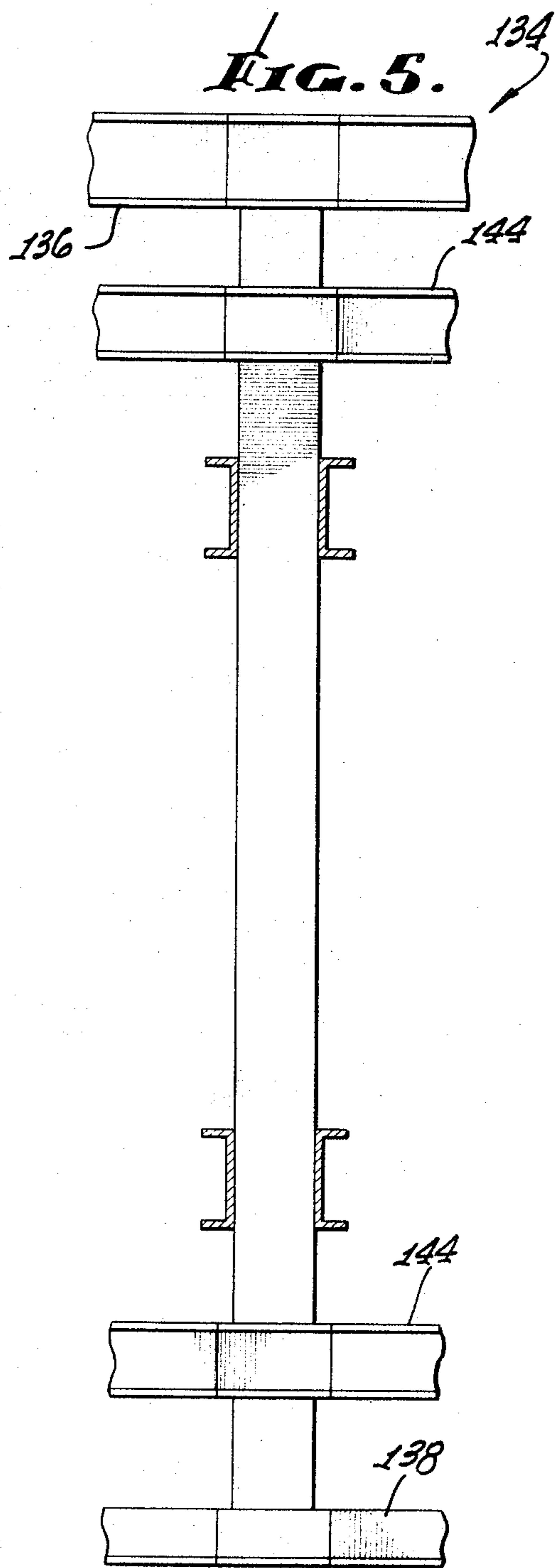
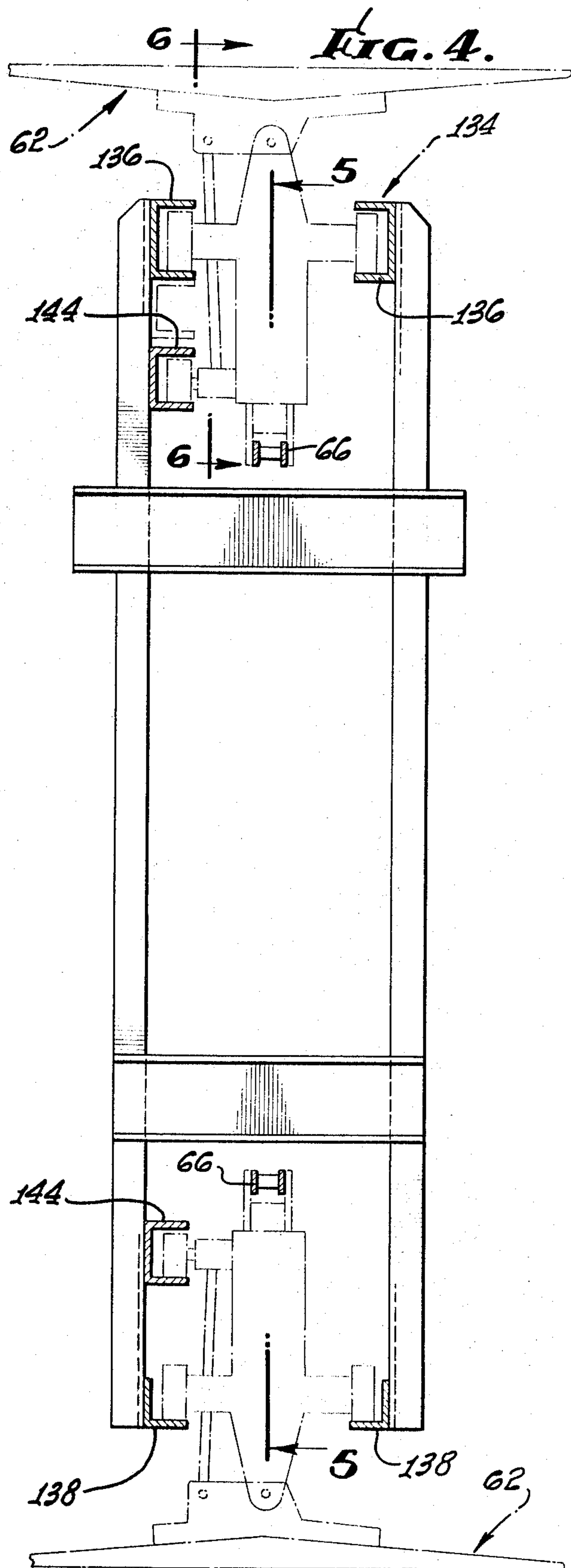

INVENTOR.
DONALD C. MULLER
By Huebner & Wornel
ATTORNEYS.

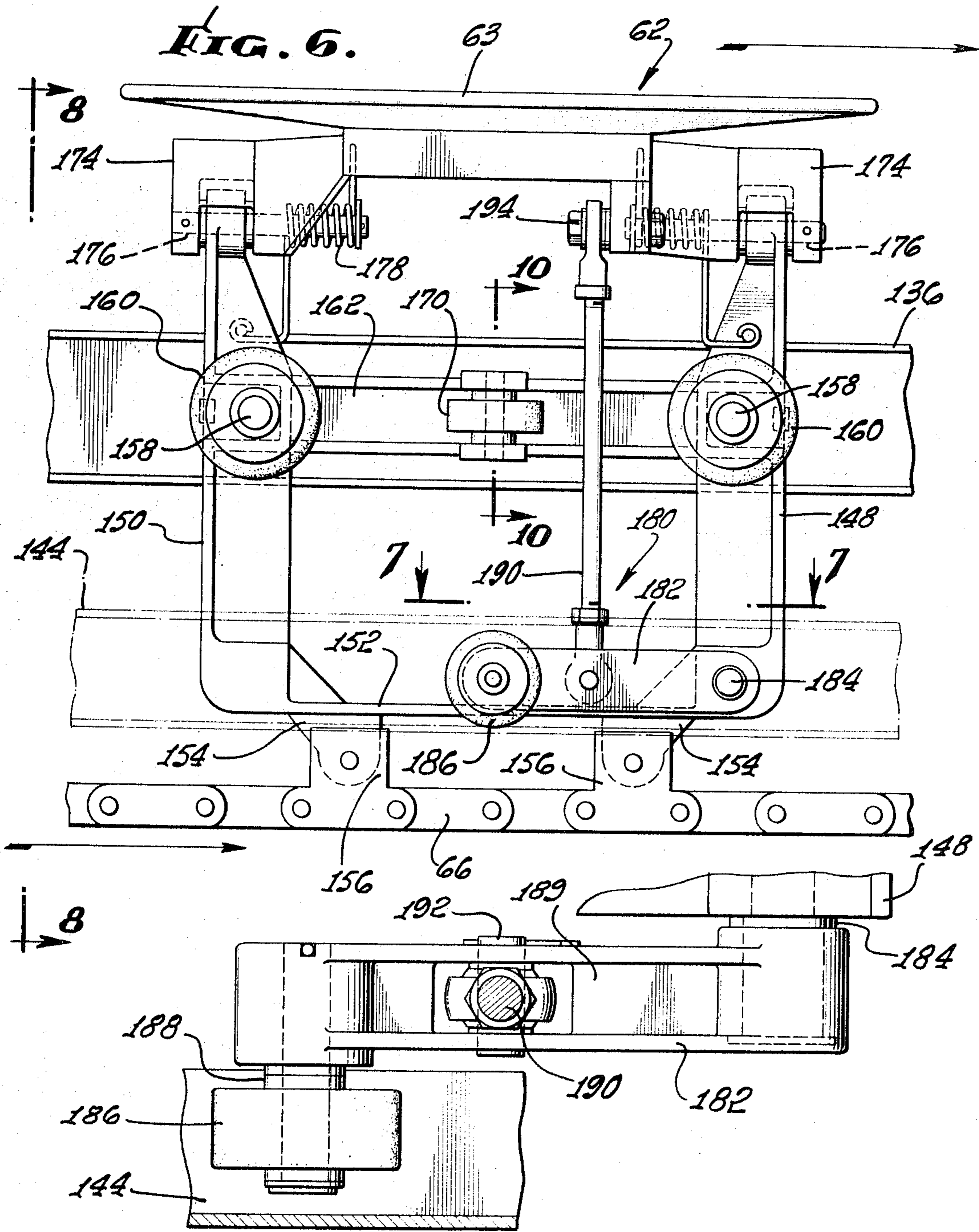

FIG. 7.

INVENTOR.
DONALD C. MULLER
By *Huetner & Worel*
ATTORNEYS.

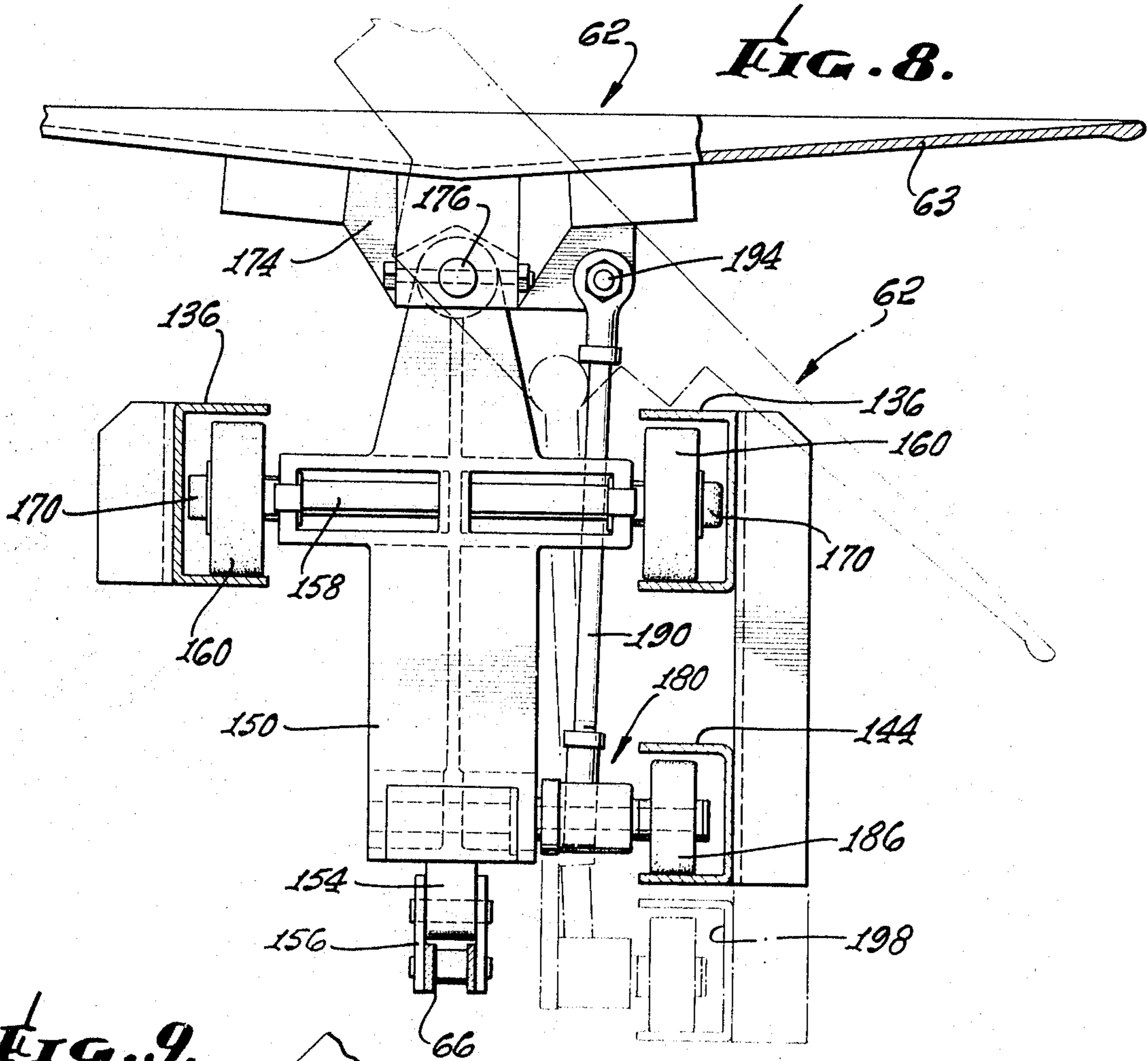

FIG. 9.

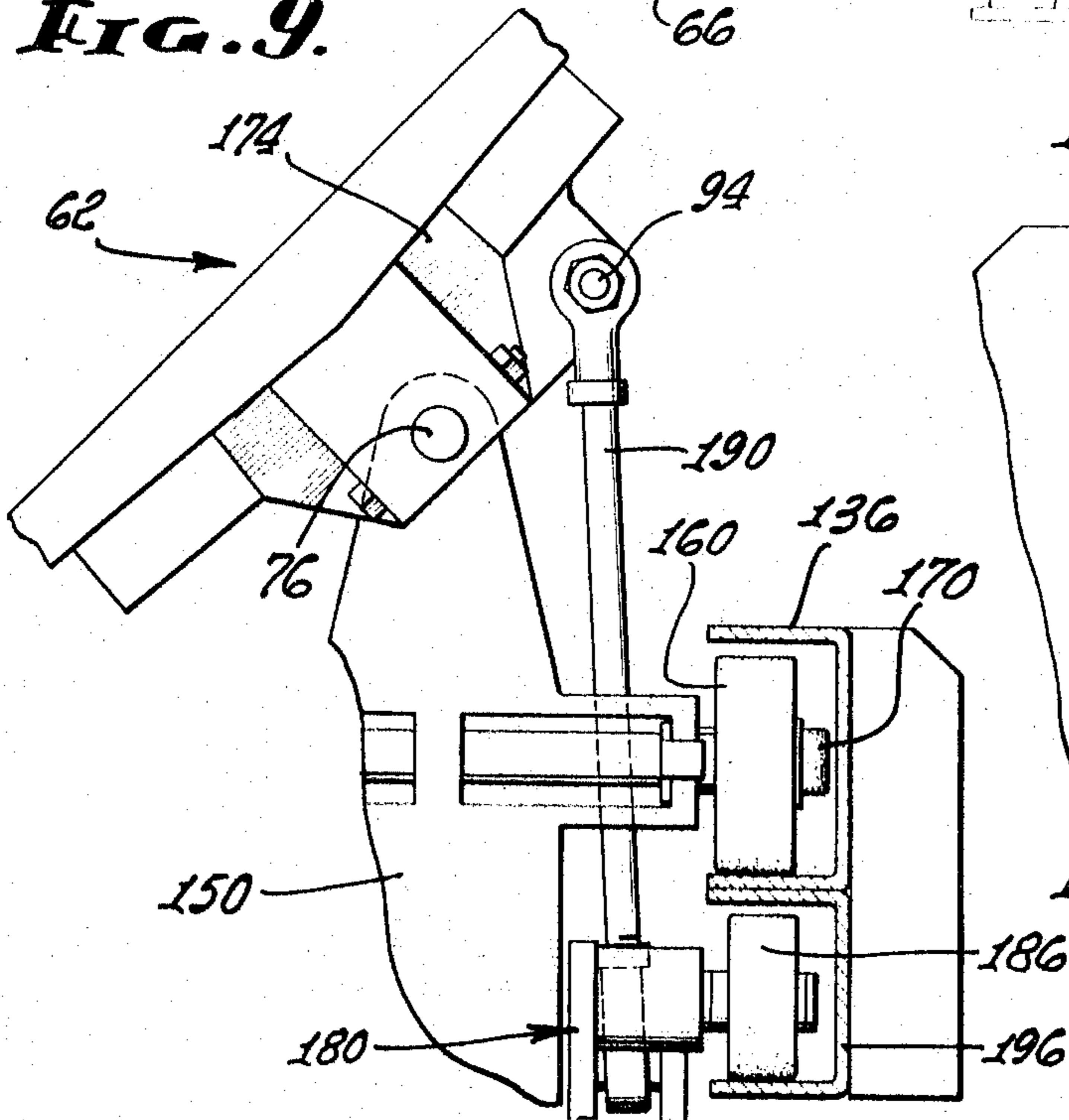
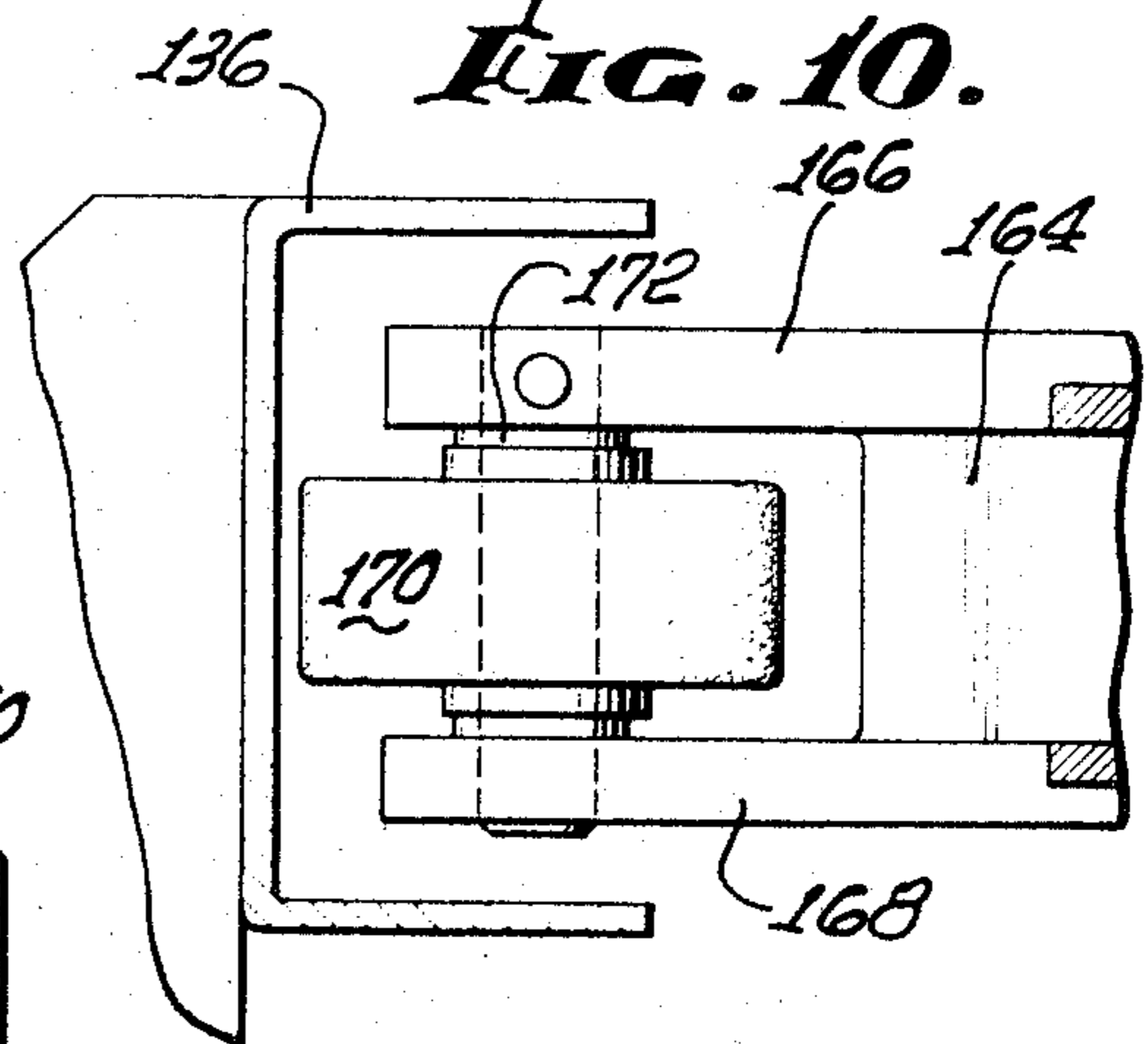

FIG. 10.



INVENTOR.
DONALD C. MULLER

By *Hubner & Worrel*
ATTORNEYS.

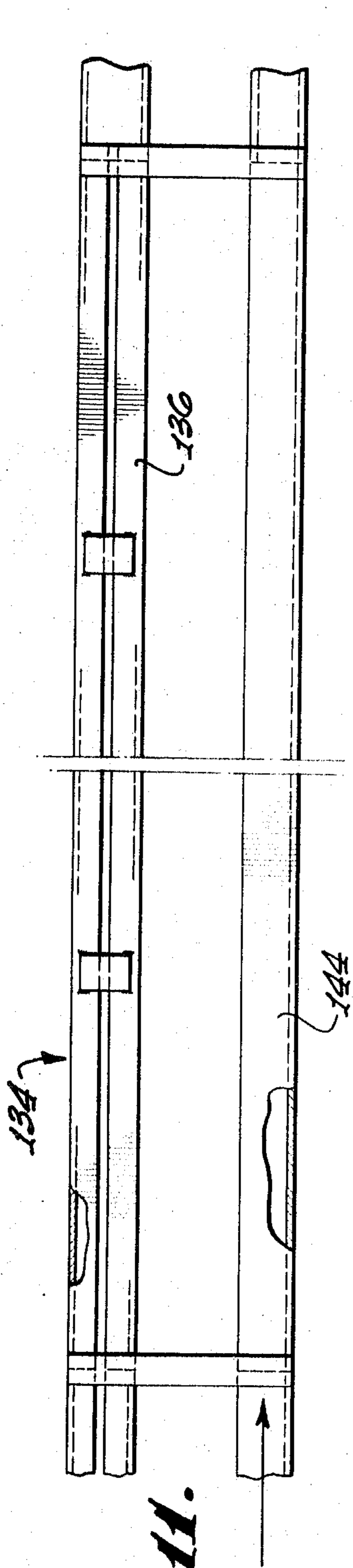

FIG. 11.

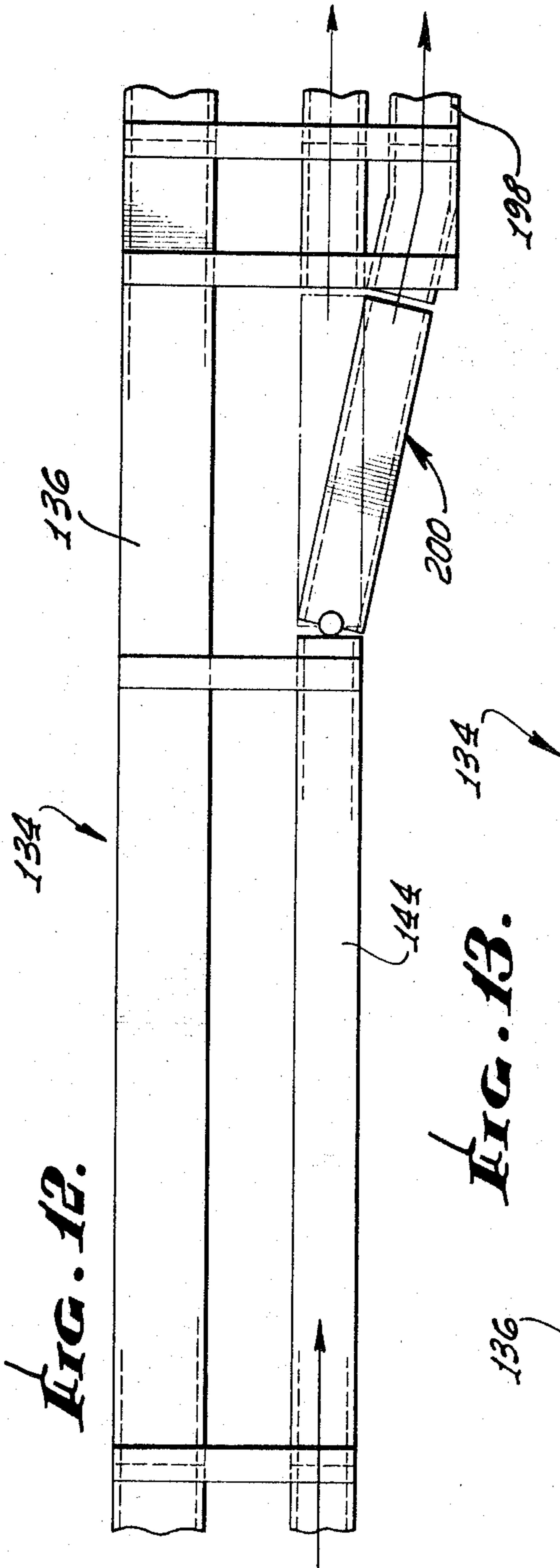

FIG. 12.

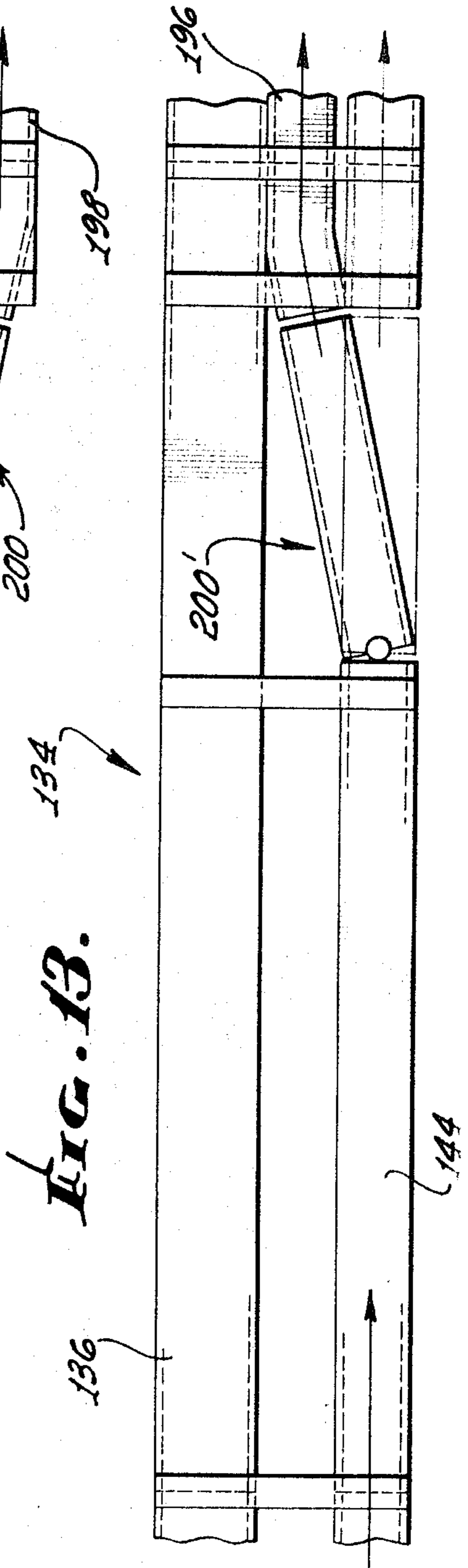

FIG. 13.

INVENTOR.
DONALD C. MULLER

By
Heubner & Wond
ATTORNEYS.

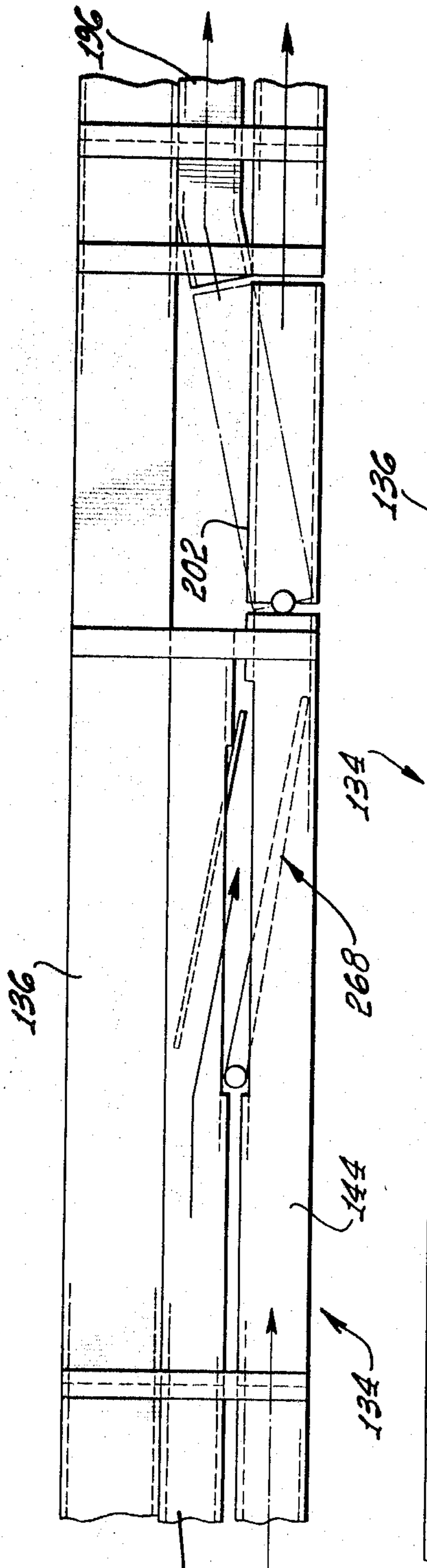

FIG. 14.

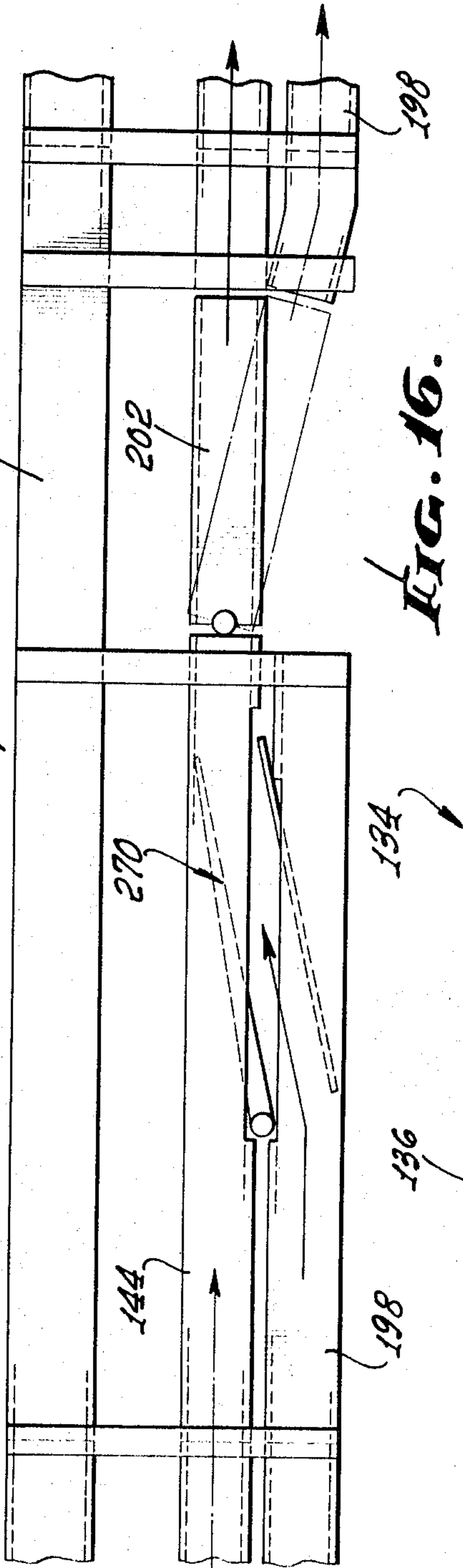

FIG. 15.

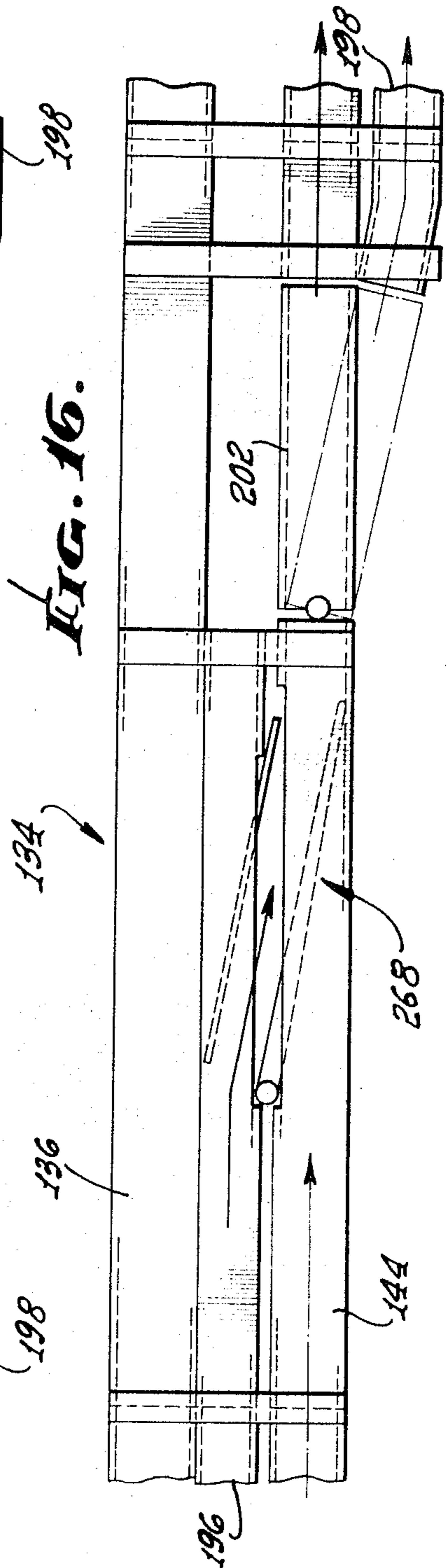

FIG. 16.

INVENTOR.
DONALD C. MULLER

By *Huelmer & Worrel*
ATTORNEYS.

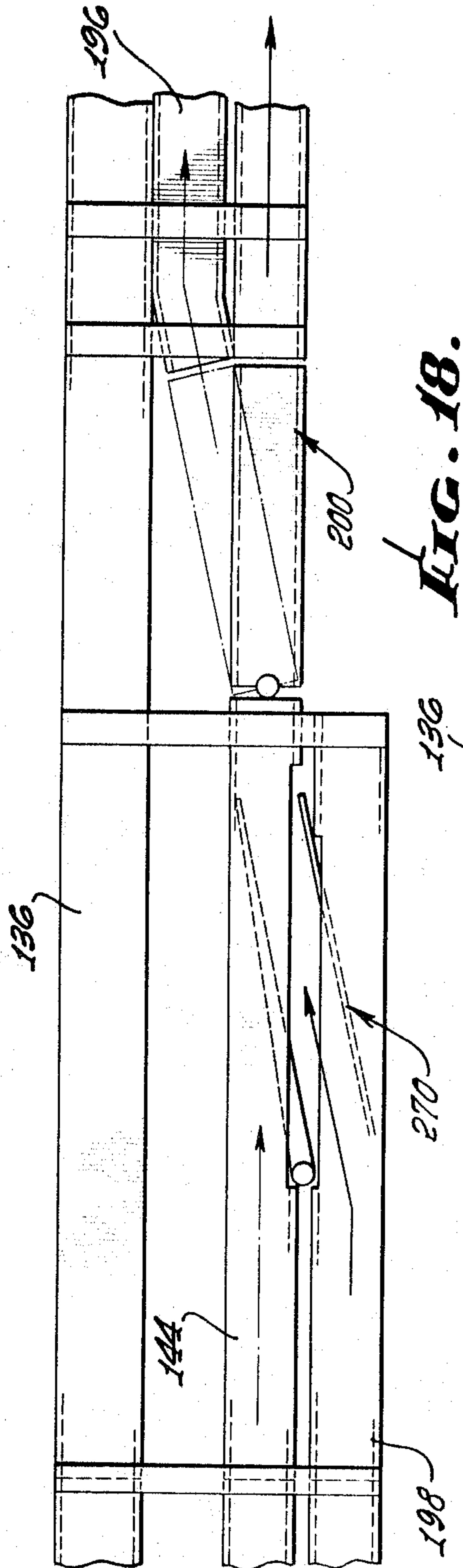

FIG. 17.

FIG. 18.

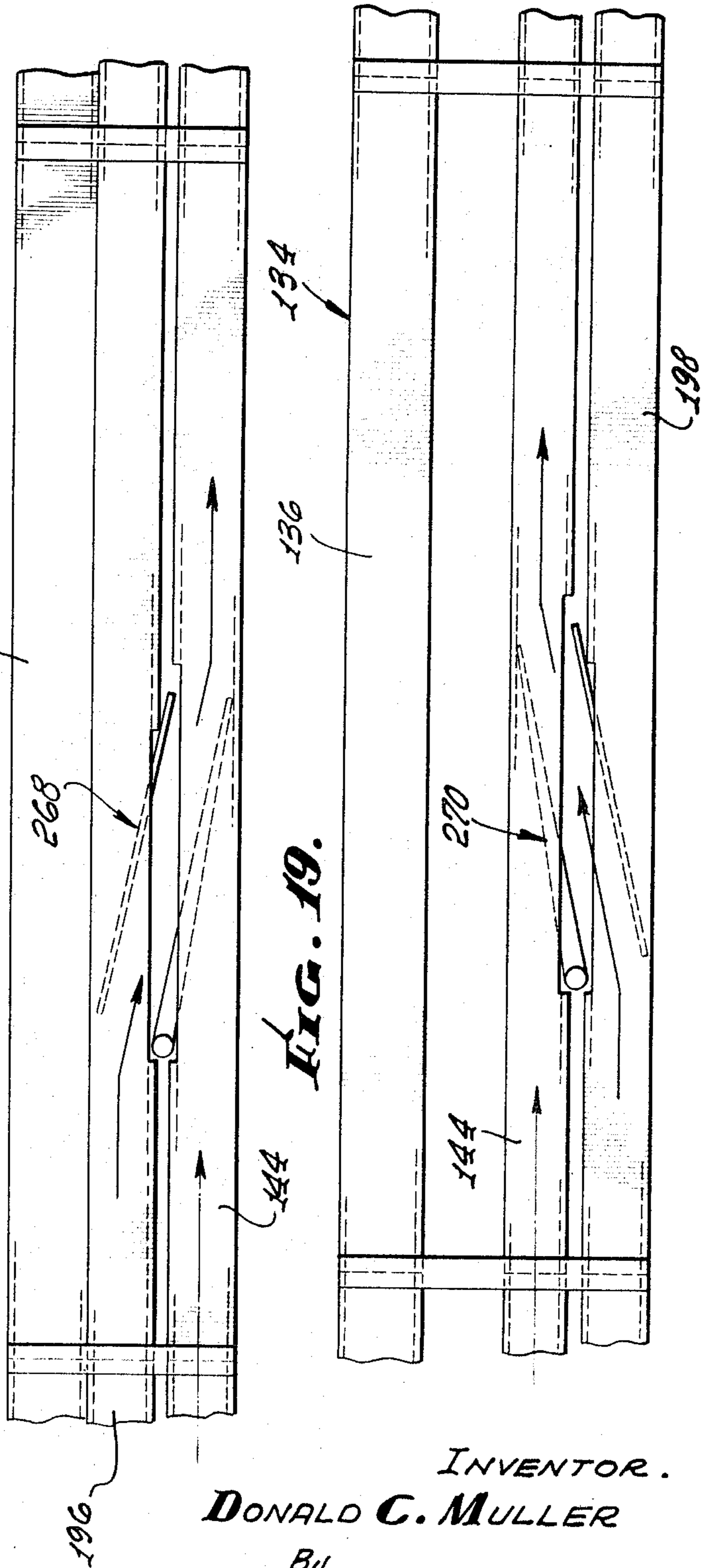

FIG. 19.

INVENTOR.
DONALD C. MULLER

By *Huebner & Howell*
ATTORNEYS.

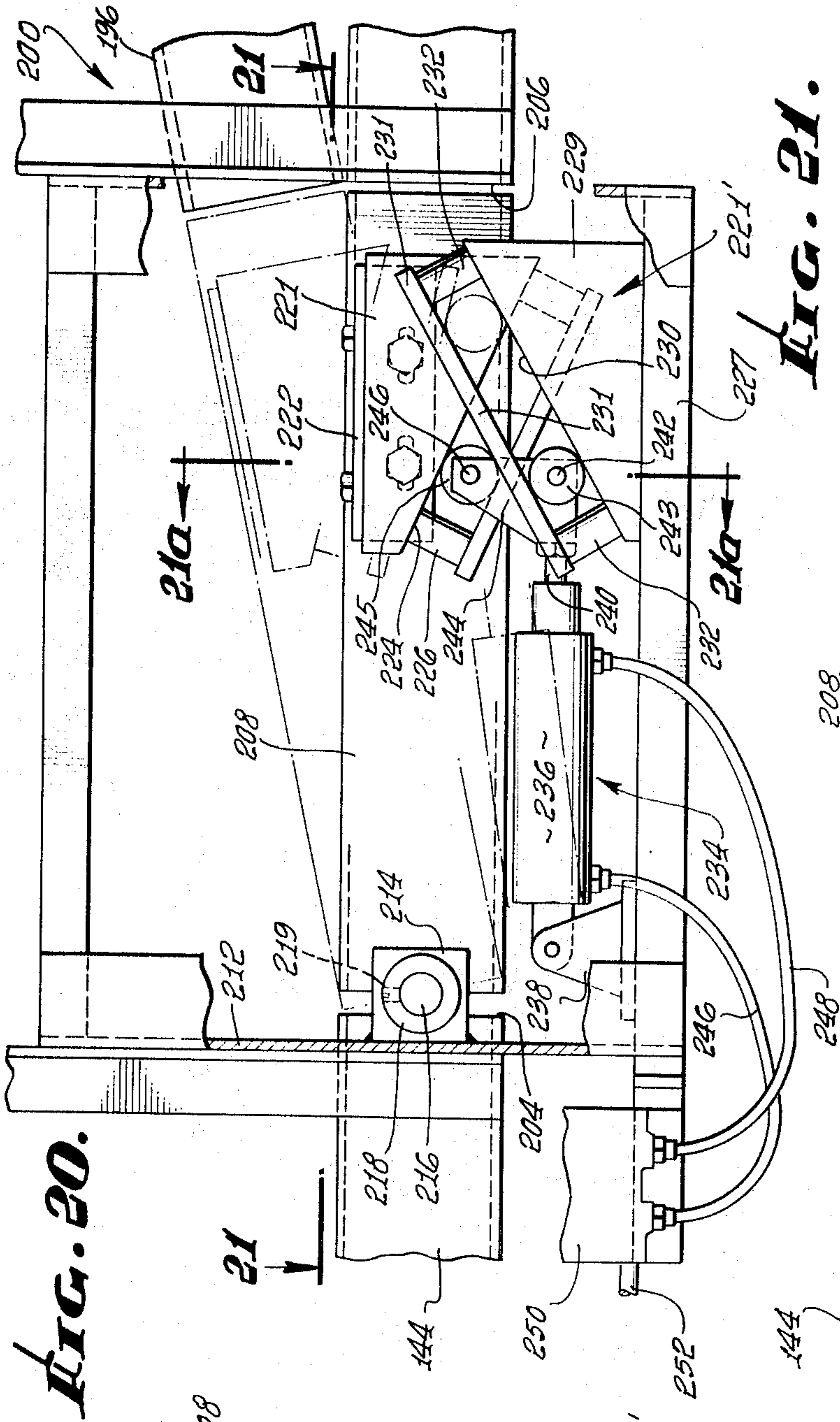

FIG. 20.

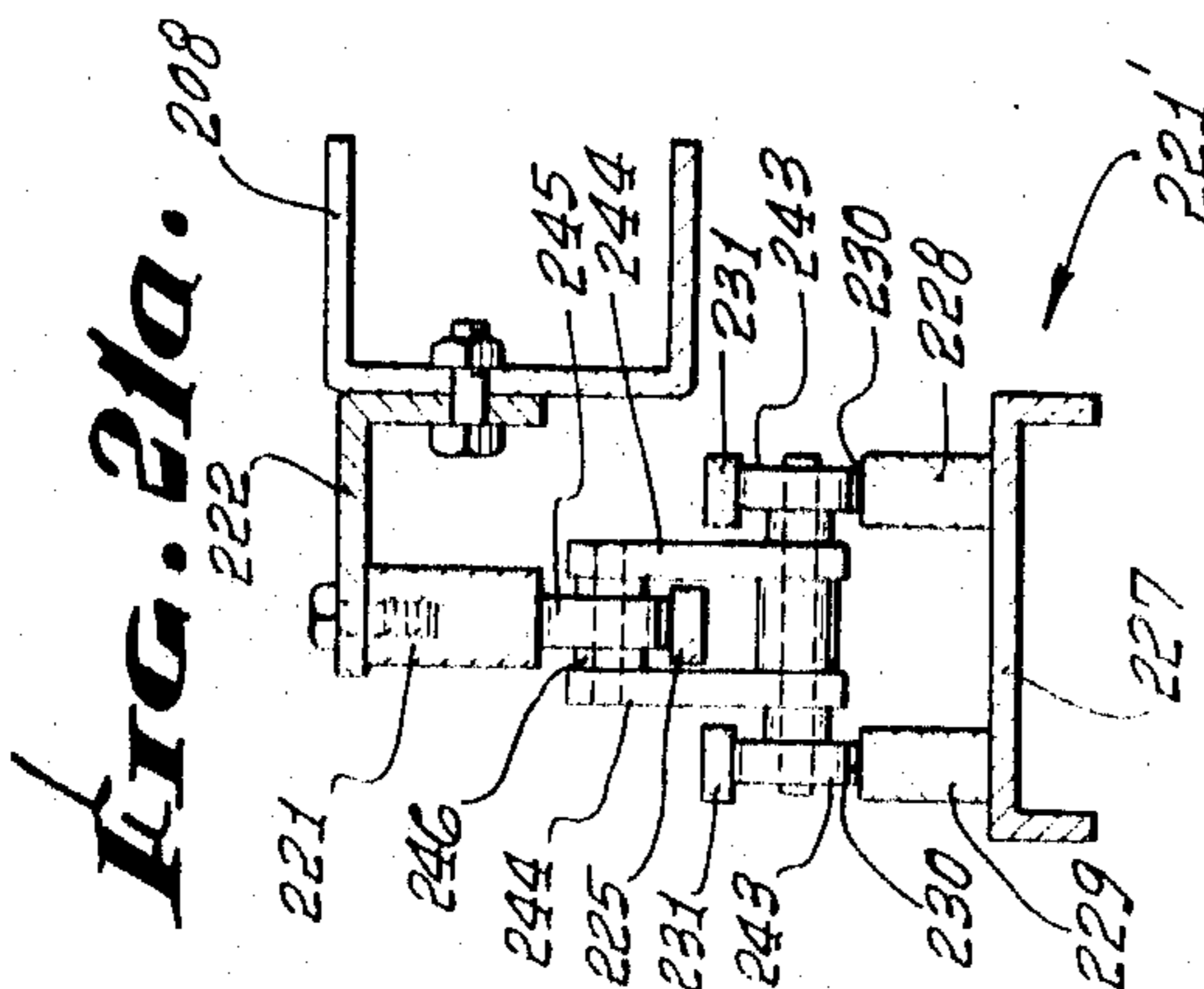
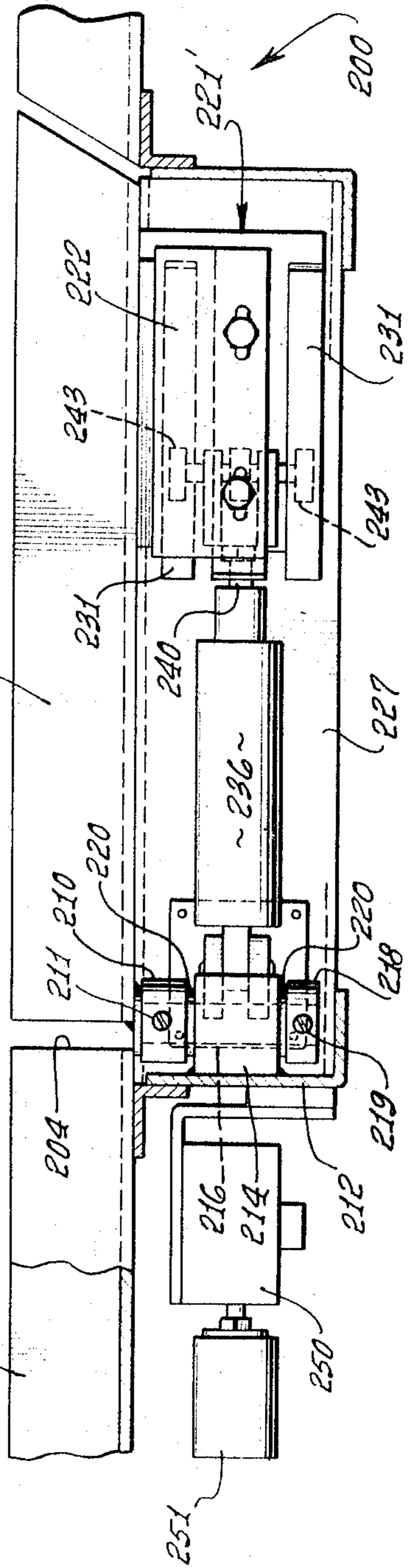

FIG. 21a.

FIG. 21.



INVENTOR.
DONALD C. MULLER

By
Huebner & Wood
ATTORNEYS.

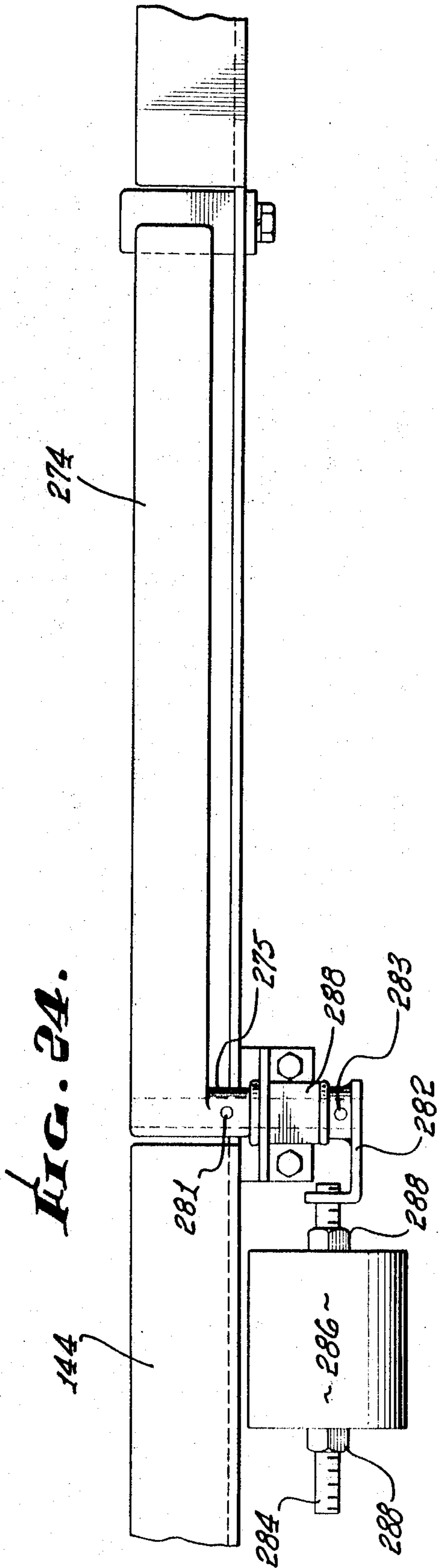

FIG. 26.

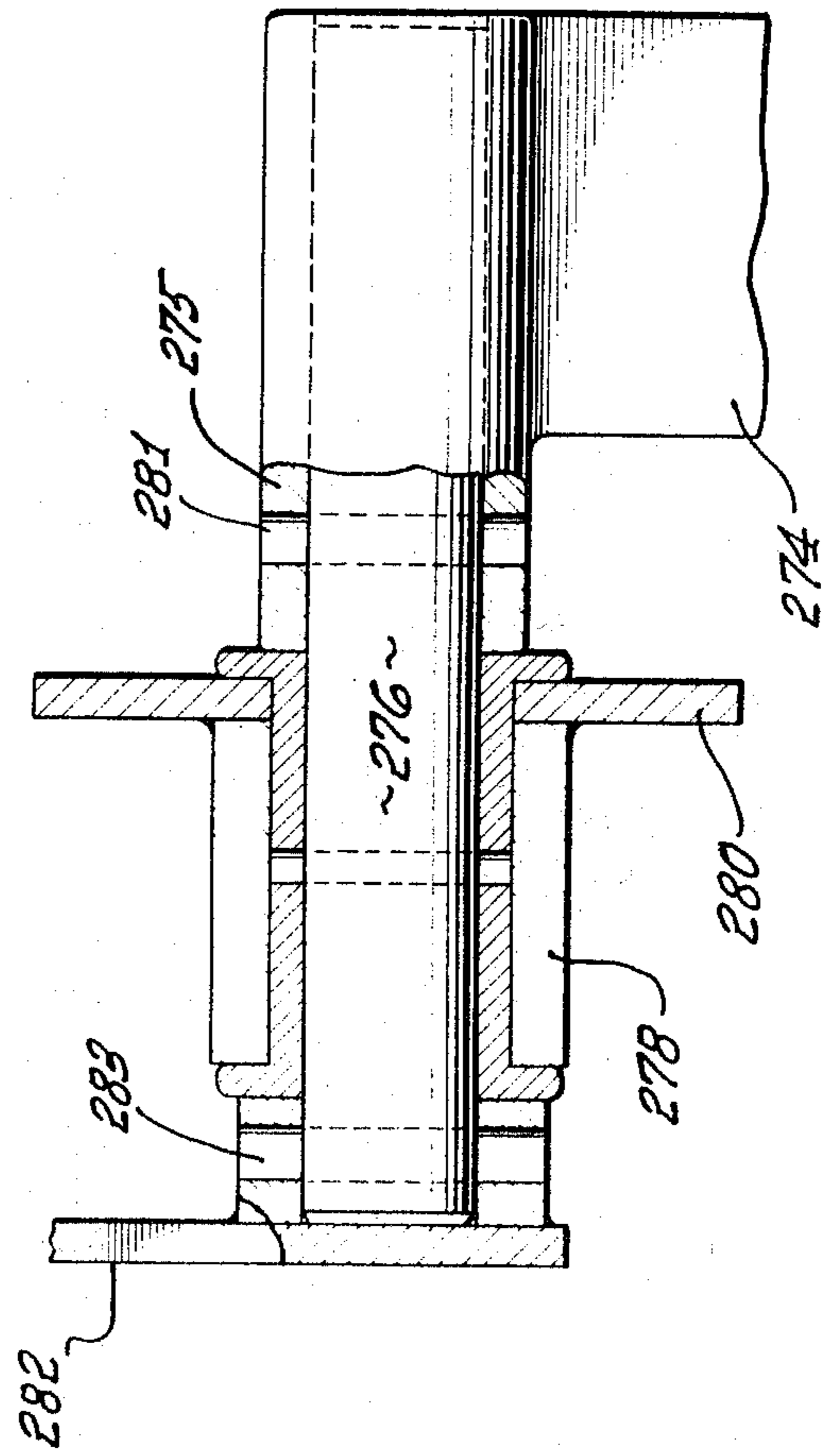
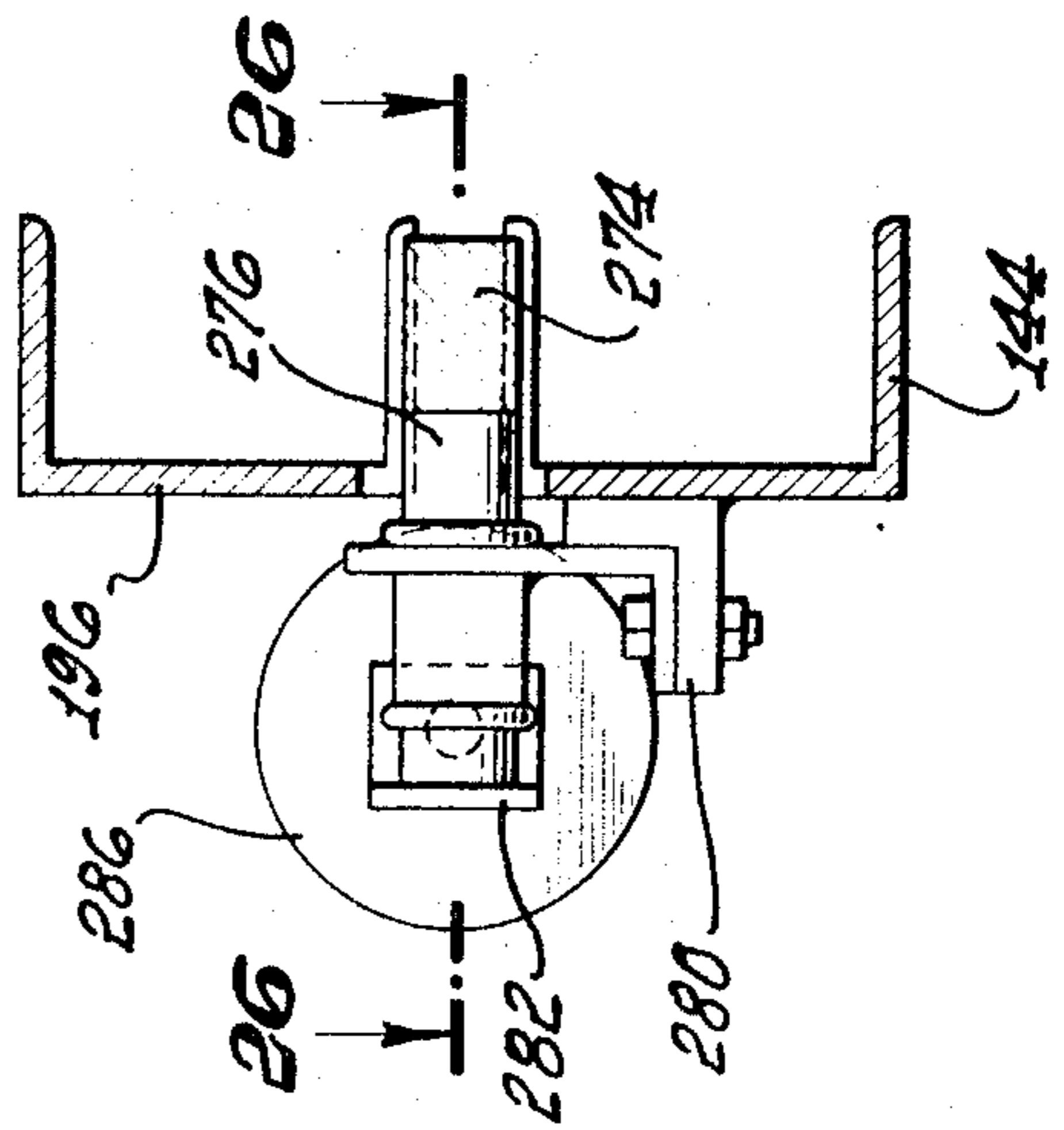

FIG. 25.



INVENTOR.
DONALD C. MULLER

By *Huebner & Worel*
ATTORNEYS.

FIG. 27.

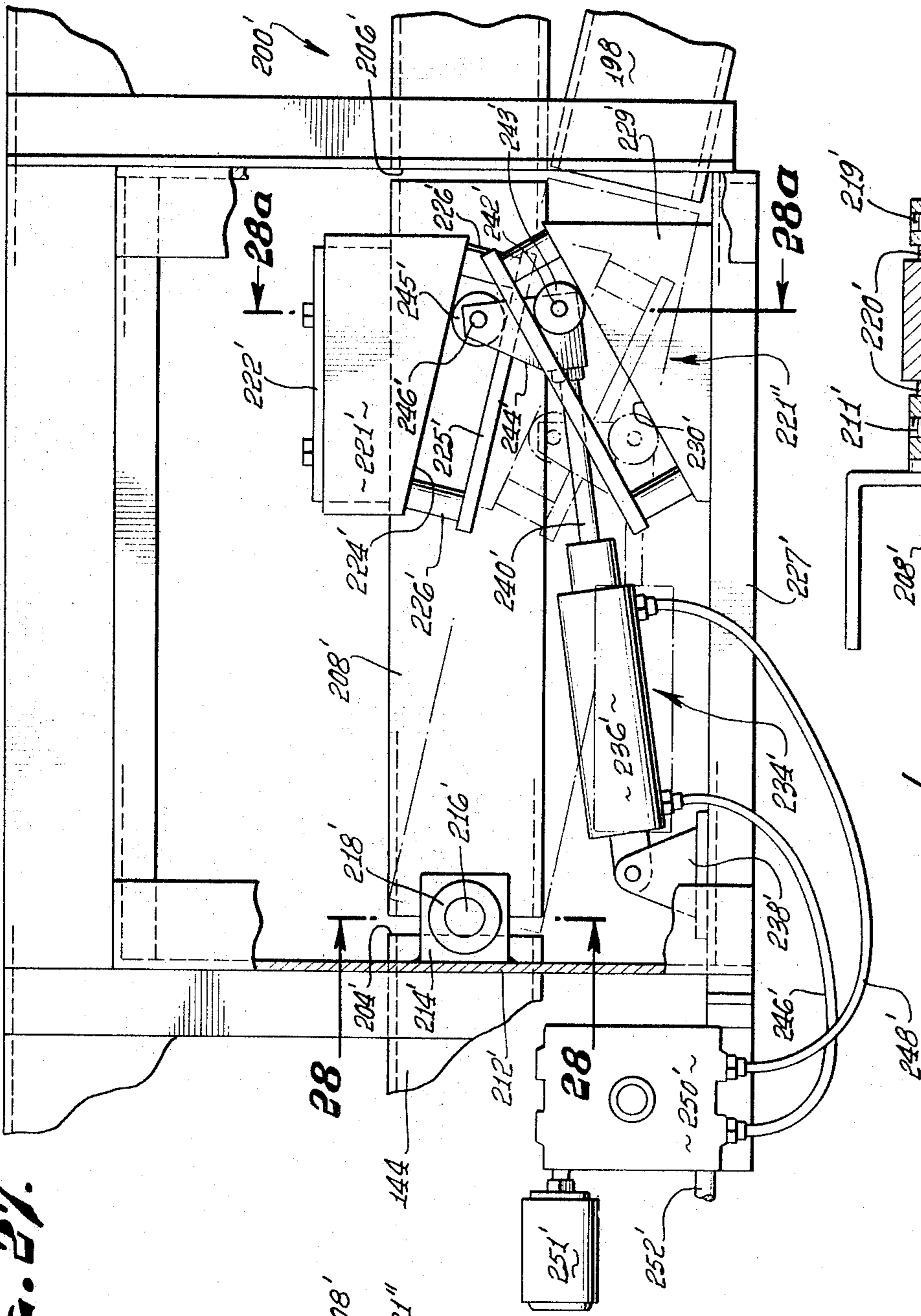

FIG. 28a.

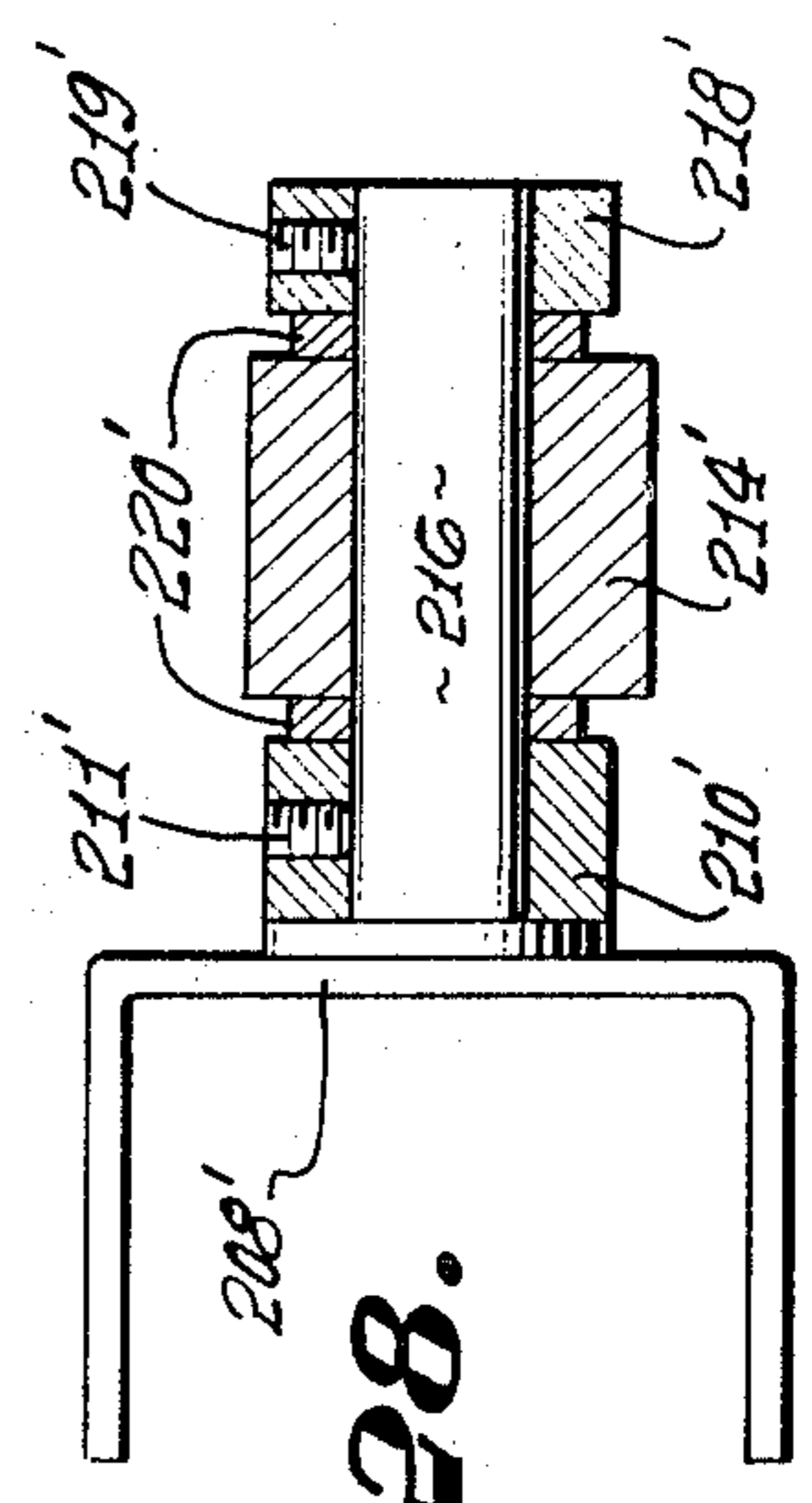
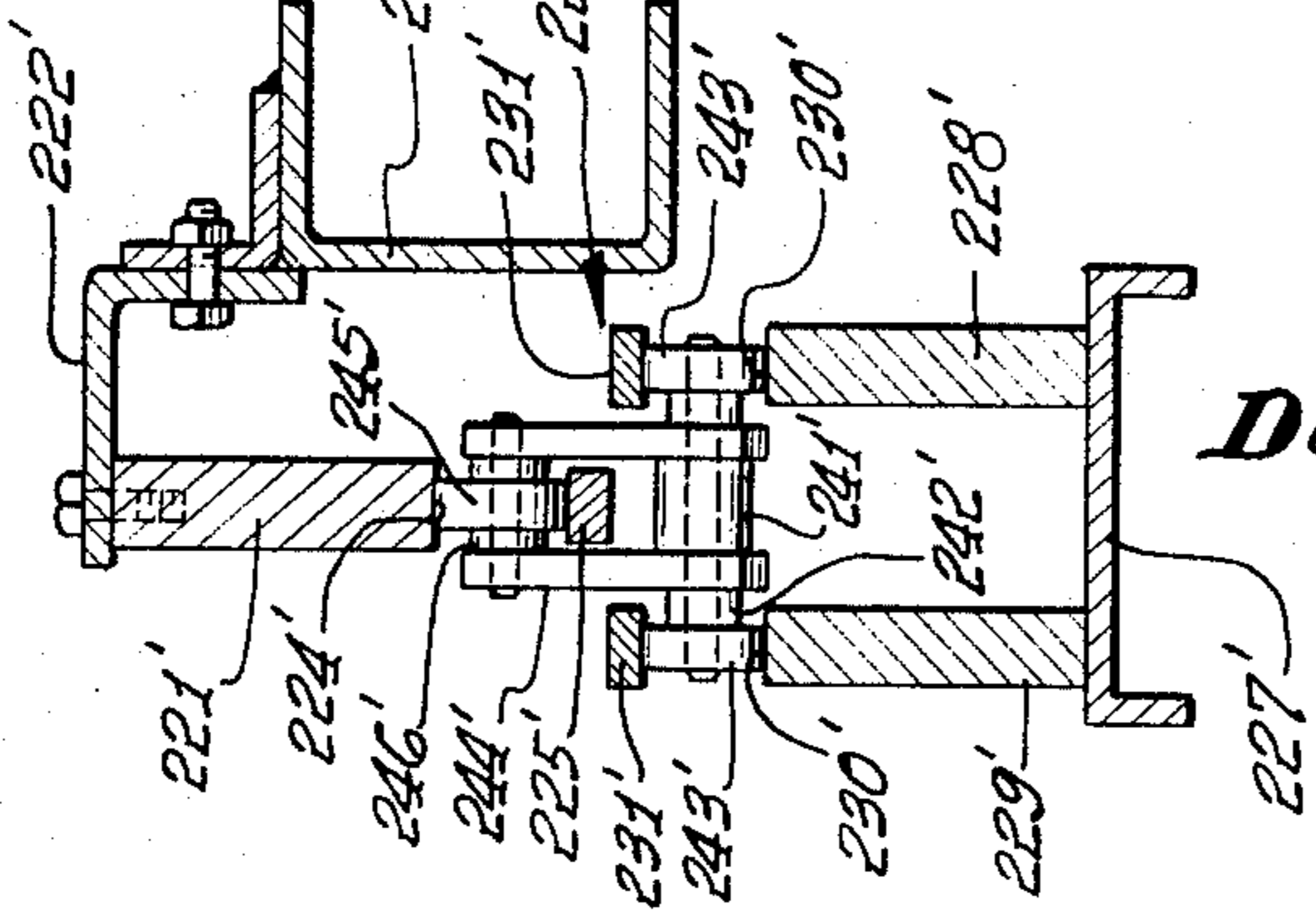
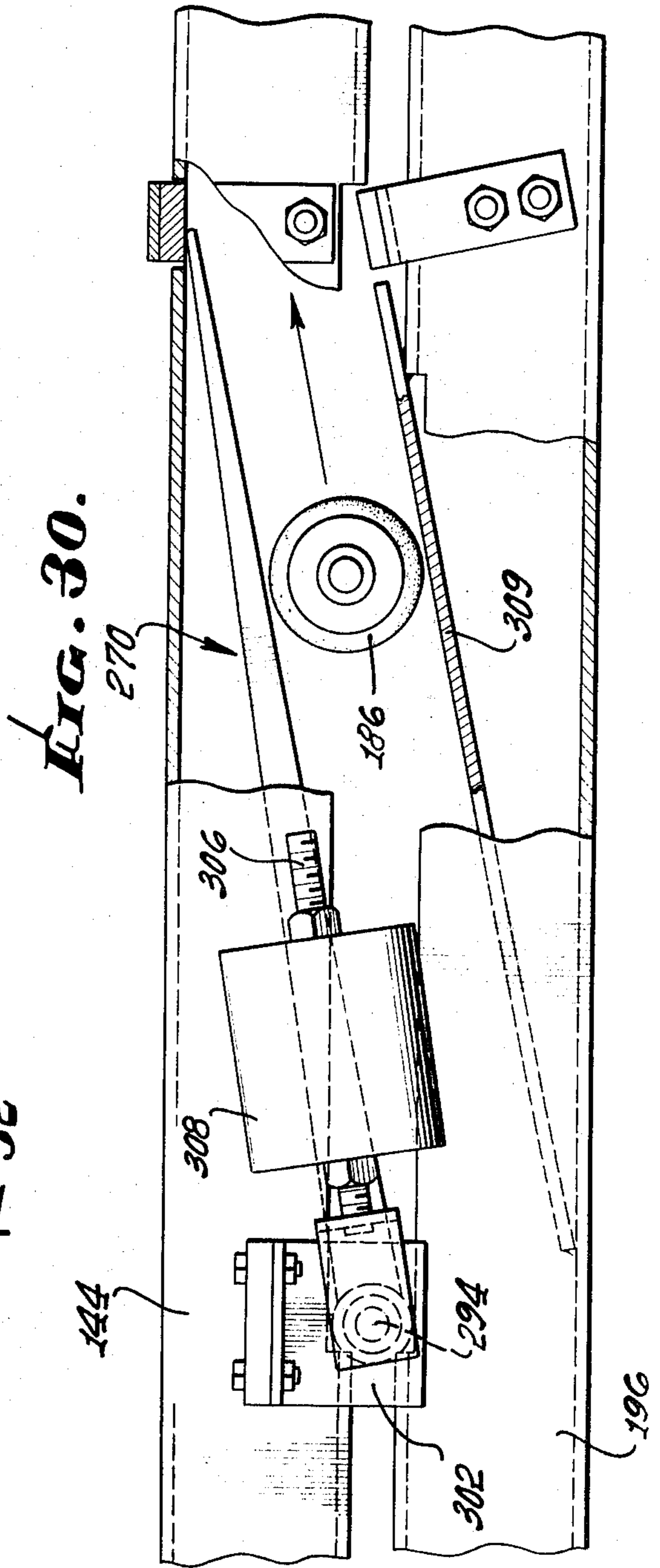
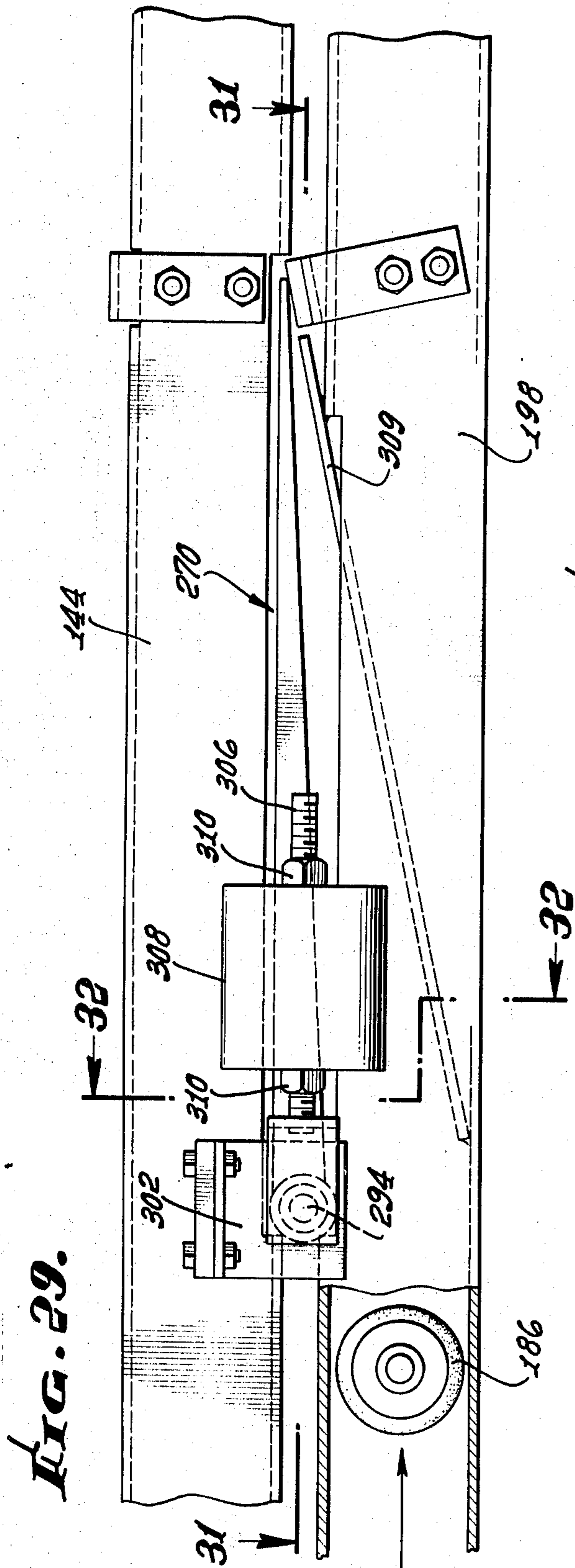

FIG. 28.

INVENTOR
DONALD C. MULLER

By *Huebner & Worrel*
ATTORNEYS.



INVENTOR.
DONALD C. MULLER

By *Heubner & Wornel*

ATTORNEYS.

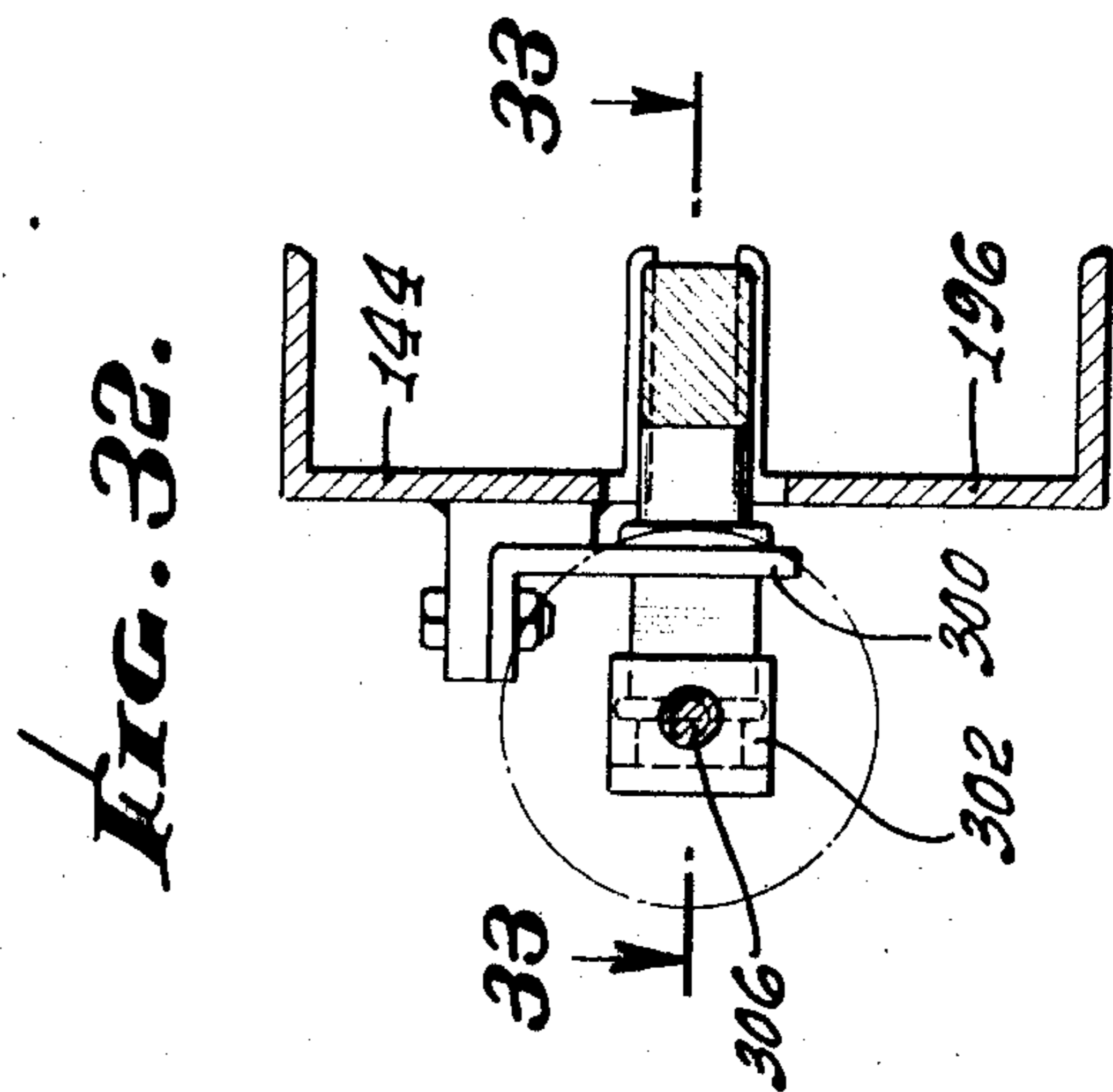
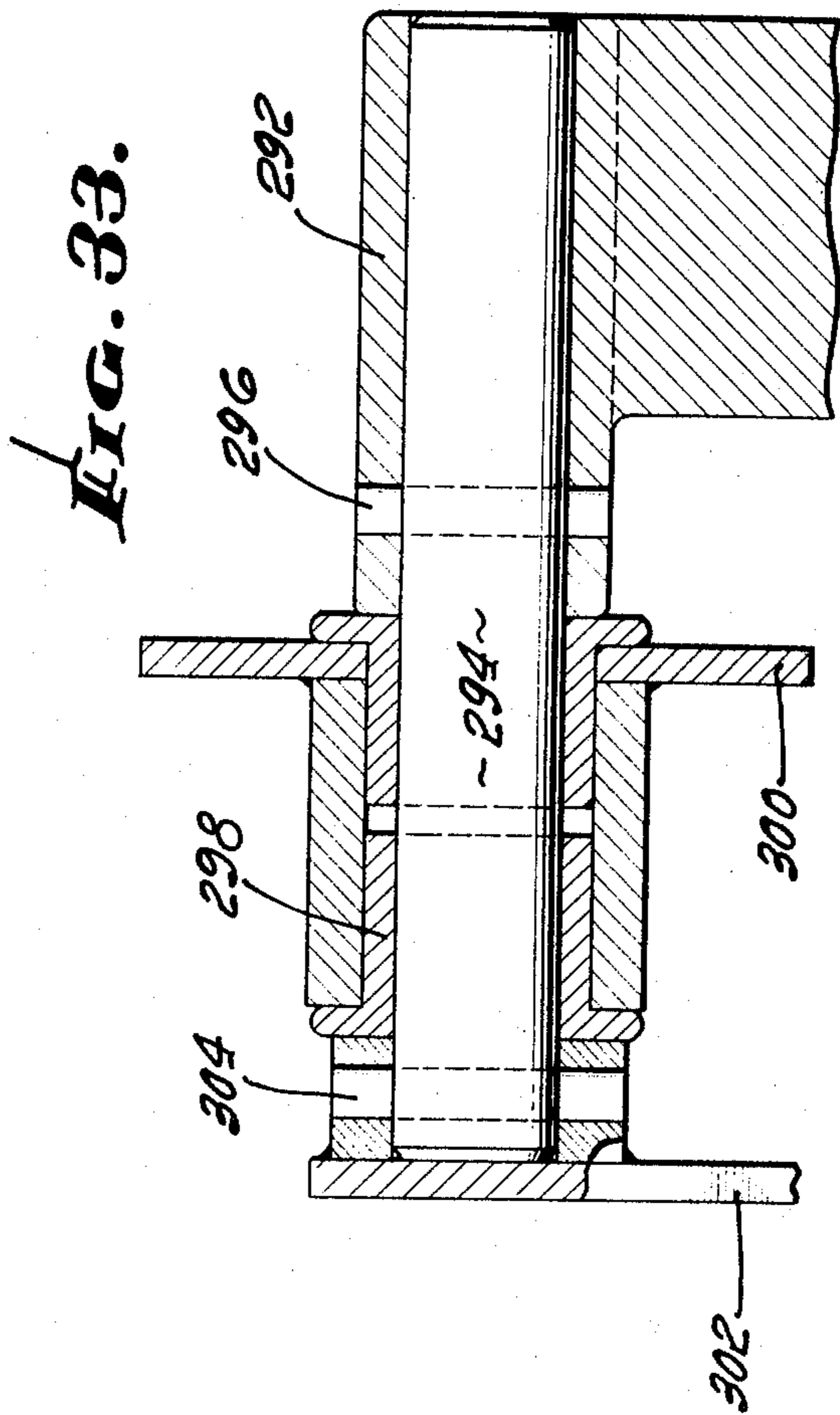
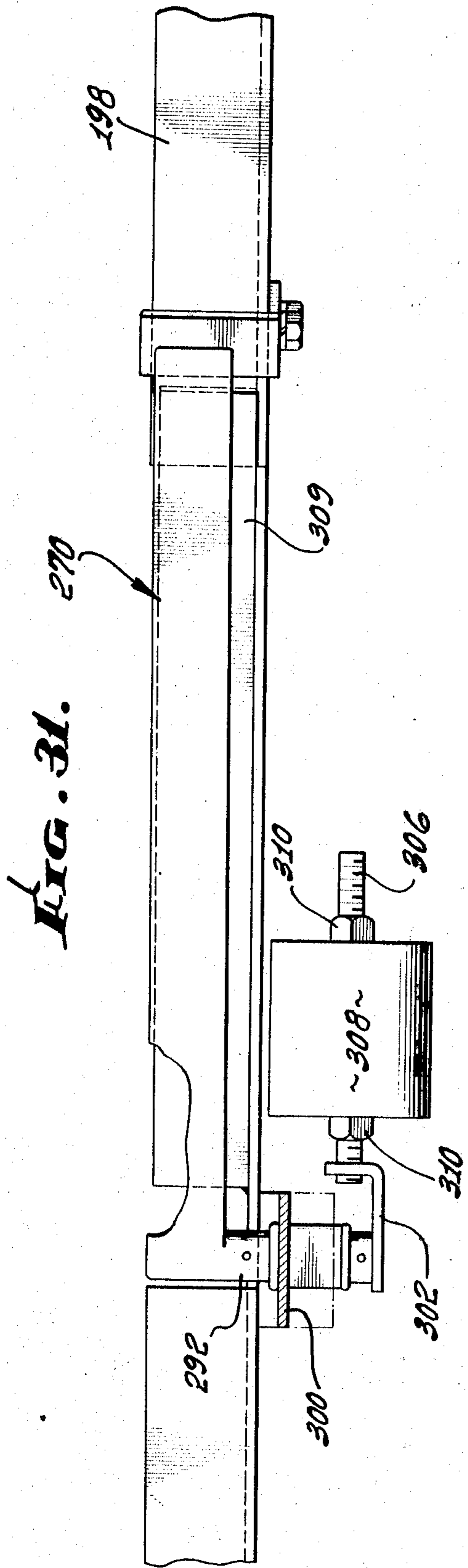

INVENTOR.
DONALD C. MULLER
 By *Huebner & Ward*
 ATTORNEYS.

FIG. 34.

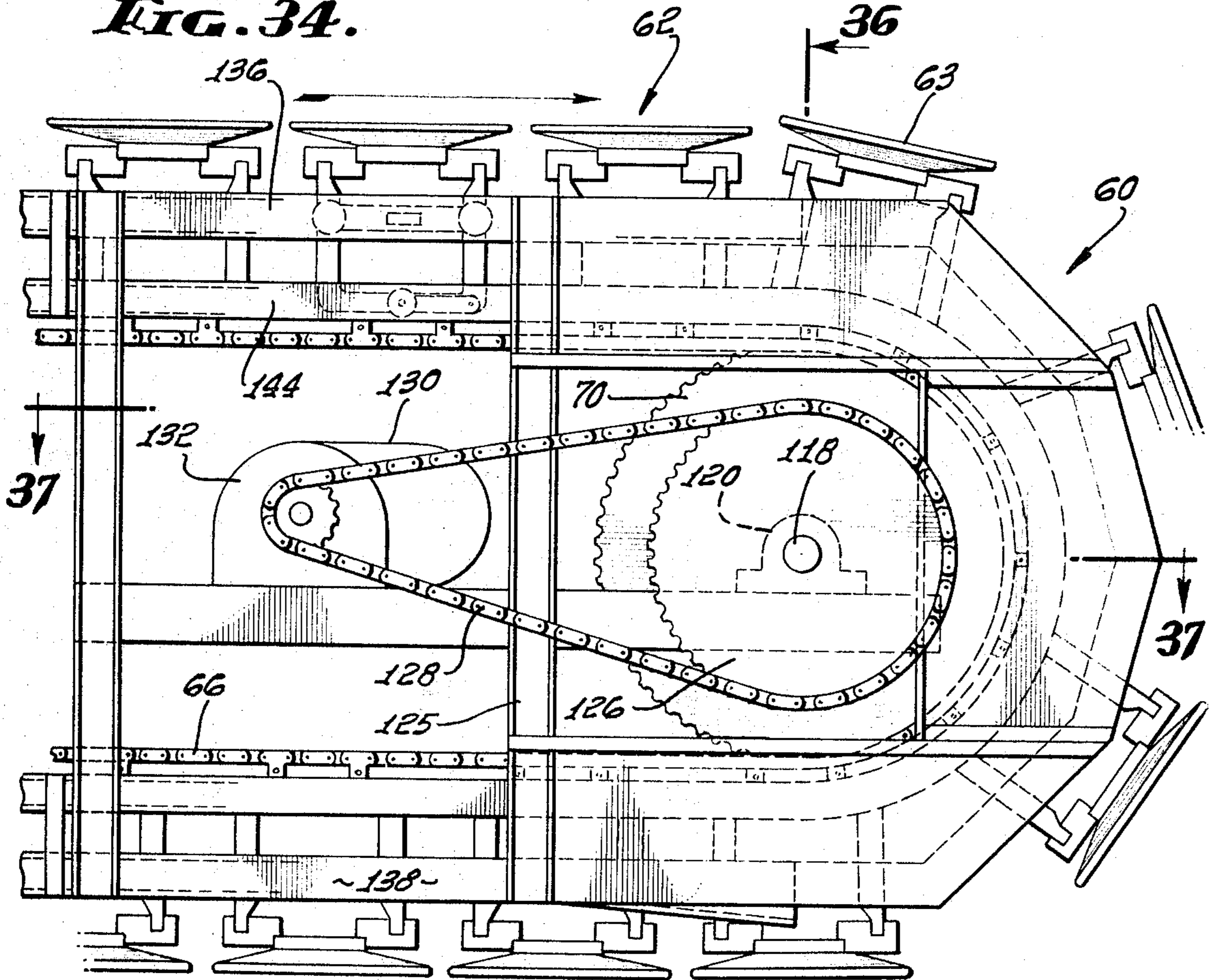
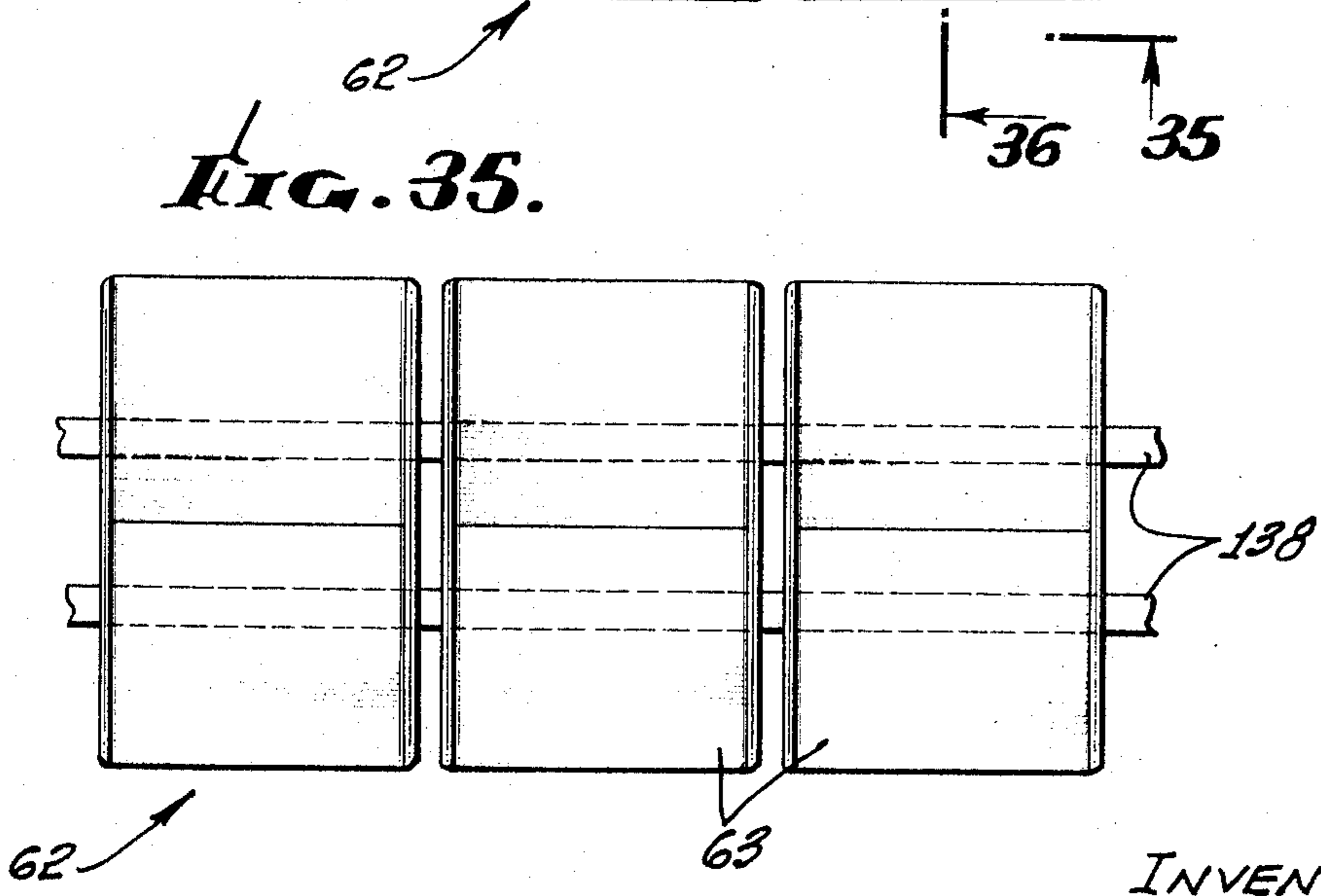

FIG. 35.



INVENTOR.
DONALD C. MULLER

By *Hubner & Worrel*
ATTORNEYS.

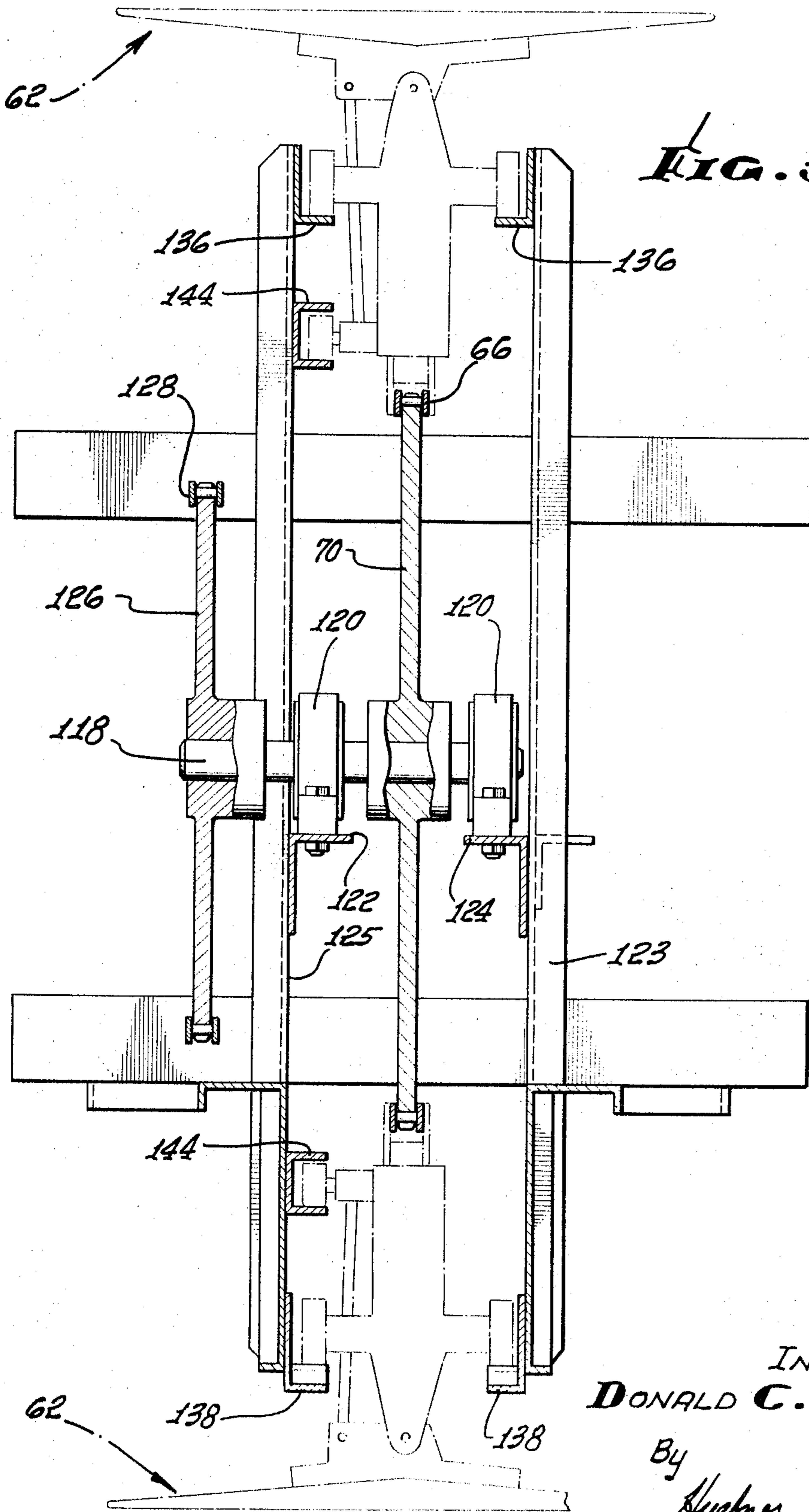

FIG. 36.

INVENTOR.
DONALD C. MULLER

By
Hubner & Worrel
ATTORNEYS.

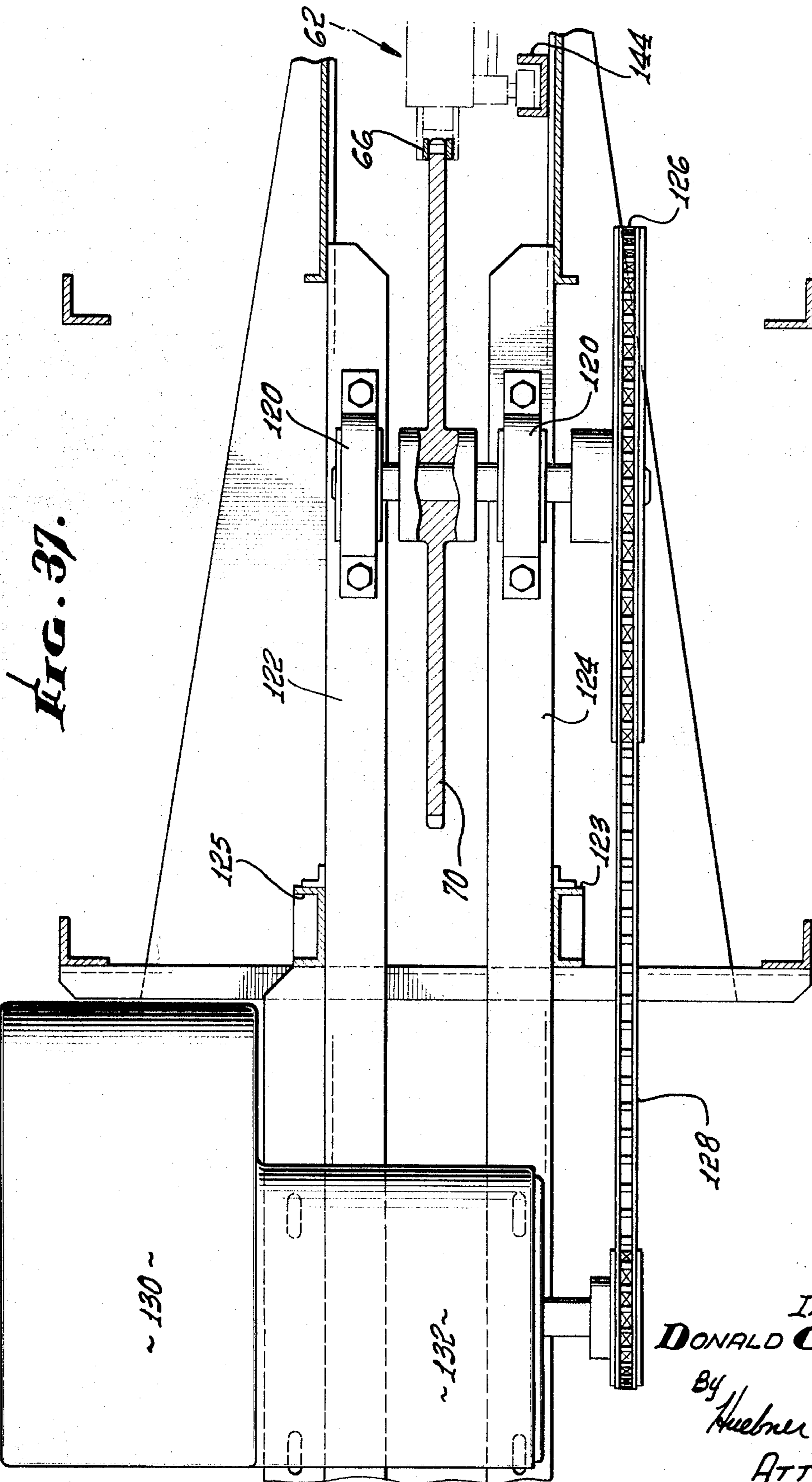

FIG. 37.

INVENTOR.
DONALD C. MULLER

By *Heubner & Warral*
ATTORNEYS.

PARCEL SORTING CONVEYOR SYSTEM

BACKGROUND OF THE INVENTION

Heretofore in conveyor and sorting systems, certain mechanical features, by way of physical deflecting barriers have been utilized in the path of travel of the conveyor to discharge parcels or items traveling along the conveyor system. Also, other systems require the use of human labor to physically remove parcels at designated areas which is cumbersome and expensive.

Also, when using barriers to deflect even if mechanically activatable it requires relatively short conveyor systems where the barriers are clearly visible to an operator, or if longer conveyors are utilized, additional personnel are required in the area of the barrier to assure proper actuation as to timing and placement.

Some of the prior art has utilized a belt type of conveyor which can increase the problem of appropriate discharge at the place desired of the parcels spaced therealong because of bunching and lack of pre-sorting into designated groups.

SUMMARY OF THE INVENTION

It is the object of this invention to provide a plurality of contiguous receptacles wherein parcels may be pre-sorted and placed thereon and selectively discharged by gravity normal to the line of travel of the parcel sorting conveyor system. This invention is particularly helpful in the sorting of mail, parcels and other items where a relatively large and continuous volume is encountered.

With this invention it is only necessary that there be a console at one end of the conveyor system whereby a person may, by any appropriate control means, activate deflector means embodied in this invention whereby the individual receptacles may be tilted to the right or left of the line of travel and gravity will cause parcels thereon to exit from the conveyor to a sub-conveyor, platform or other further sorting device.

Each of the contiguous parcel receiving receptacle means of this invention is separate and tiltable to the right or left of the line of travel or remain horizontal upon command. The conveyor system would generally be referred to as an endless conveyor means which carries parcels in the receptacles along the top of the conveyor to a desired location where the receptacles are tilted and emptied then reset to a parcel receiving position and pass around the ends of the conveyor means below the top receptacles and then back around the other end ready for loading and discharge in the upper or top position.

These and other objects and advantages will become apparent from the following description and drawings.

BRIEF DESCRIPTION OF THE DRAWINGS

FIG. 1 is a top elevational, environmental view of several parcel sorting conveyor systems embodying the features of this invention;

FIG. 2 is a side elevational view taken on line 2—2 of FIG. 1 illustrating the head end of a parcel sorting conveyor means;

FIG. 3 is a cross sectional, partially in phantom view taken on line 3—3 of FIG. 2;

FIG. 4 is a cross sectional view, partially in phantom, taken on line 4—4 of FIG. 2;

FIG. 5 is a cross sectional view of a part of the rail guide assembly of the deflector means and reset deflector means taken on line 5—5 of FIG. 4;

FIG. 6 is a side elevational view taken on line 6—6 of FIG. 4 illustrating one of the contiguous receptacles and its associated receptacle carriage unit;

FIG. 7 is an exploded top elevational view partly in section, taken along line 7—7 of FIG. 6 illustrating additional details of a receptacle carriage unit;

FIG. 8 is a view of the receptacle and receptacle carriage unit, partially in phantom, together with a portion of the guide track assembly deflector means and reset deflector means taken on line 8—8 of FIG. 6;

FIG. 9 is a view similar to FIG. 8 illustrating deflector means which may be employed to cause tilting of the receptacle in a left direction to the line of travel;

FIG. 10 is a slightly enlarged detailed view of a stabilizing guide roller of the receptacle carriage unit taken on line 10—10 of FIG. 6;

FIGS. 11 through 19 illustrate various combinations of the guide track assembly, deflector means and reset deflector means which are utilized to cause tilting and righting of the receptacles;

FIG. 20 is a detailed side elevational view of a left deflector means interposed in the guide track assembly;

FIG. 21 is a sectional view taken on line 21—21 of FIG. 20;

FIG. 21a is a sectional view taken on line 21a—21a of FIG. 20;

FIG. 22 is a side elevational view of a left reset deflector means;

FIG. 23 is a view similar to FIG. 22 but partially in section showing the left reset deflector means in a different position;

FIG. 24 is a top elevational view of the left reset deflector means taken on line 24—24 of FIG. 22;

FIG. 25 is a vertical sectional view taken on line 25—25 of FIG. 22;

FIG. 26 is an enlarged detailed sectional view taken on line 26—26 of FIG. 25;

FIG. 27 is a side elevational view of a right deflector means interposed in the guide track assembly;

FIG. 28 is a detailed sectional view taken on line 28—28 of FIG. 27;

FIG. 28a is a sectional view taken on line 28a—28a of FIG. 27;

FIG. 29 is a side elevational view of a right reset deflector means;

FIG. 30 is a view similar to FIG. 29 but partially in section, illustrating the right reset deflector means in a different position;

FIG. 31 is a top elevational view of the right reset deflector means taken on line 31—31 of FIG. 29;

FIG. 32 is a vertical sectional view of a portion of the right reset deflector means taken on line 32—32 of FIG. 29;

FIG. 33 is an enlarged sectional view taken on line 33—33 of FIG. 32;

FIG. 34 is a side elevational view taken on line 34—34 of FIG. 1, illustrating the tail end of the parcel sorting conveyor means opposite the head end illustrated in FIG. 2;

FIG. 35 is a view taken on line 35—35 of FIG. 34 illustrating a plurality of contiguous receptacles;

FIG. 36 is an elevational view, partly in section, showing the drive mechanism of the conveyor means taken along line 36—36 of FIG. 34; and

FIG. 37 is a sectional view taken along lines 37—37 of FIG. 34 illustrating further details of the conveyor means drive mechanism.

DESCRIPTION OF THE PREFERRED EMBODIMENT

FIG. 1 is an environmental view of several parcel sorting conveyor means or systems generally designated 50. As can be seen there are three such parcel sorting conveyor systems 50 which are independent and for purposes of illustration, parallel one with the other. The particular system 50 is adaptable for use in Post Offices and in factories or businesses wherein it is desired to convey parcels, packages, parts, etc., along a conveyor system in relatively large volume and to sort them by depositing or deflecting the parcels, packages, parts, etc., from the conveyor system 50 during transit.

The parcel sorting conveyor system 50 move in the direction of the arrow, that is, from left to right, when viewing FIG. 1. In the preferred embodiment a loading platform generally designated 52 is built around the head end generally designated 54 of the parcel sorting conveyor system 50. Packages or parcels are preferably pre-sorted, loaded on the parcel sorting conveyor means 50 from the loading platform

52 and move to the right in the direction of the arrows until they reach a position over one of a plurality of sub-conveyors 56 which may be of any conventional design. As can be seen in the embodiment of this invention, the sub-conveyors 56 run normal to the direction of travel of the parcel sorting conveyor means 50 and preferably moving in alternating or opposed directions one from the other. There can also be provided along each of the sub-conveyors 56 a series of chutes or slides 58 for the final discharge of parcels from the sub-conveyor 56.

The length of the parcel sorting conveyor means 50 is immaterial and may be adapted to each specific need depending on the size of the building, the types of parcels to be distributed and other factors not important for the purpose of this invention.

Each of the parcel sorting conveyor means 50, besides having a head end 54 includes an outer or tail end generally designated 60. The operation of the parcel sorting conveyor means 50 is preferably a continuous motor driven operation wherein any of a number of types of control means may be provided to activate apparatus of this invention to discharge parcels to the sub-conveyors 56. One form of such control could be the utilization of a console on the loading platform 52 wherein a person can physically control, through electrical impulses, the deflection of the parcels at preselected positions. Another such console could be through programmed computers wherein settings are made to energize apparatus for the discharging of parcels.

The head end 54 of the parcel sorting conveyor 50 is best seen in FIG. 2 of the drawings whereas the opposite or tail end 60 of the parcel sorting conveyor means 50 is best illustrated in FIG. 34.

Generally, the parcel sorting conveyor means 50 include a plurality of parcel receiving receptacle means generally designated 62 which are contiguous and through means to be described, ride on an endless guide rail wherein when the receptacle means 62 are in a position at the top of the conveyor means 50 such as illustrated in FIG. 2, they are in a parcel loading position or normal position.

Each of the receptacle means 62 includes a fixable portion or carriage unit generally designated 64 and best seen in FIG. 6. Pivotaly secured to the unit 64 is a parcel receiving tray 63. Each of the carriage units 64 are fixed to an endless sprocket chain 66 which extends around a rear sprocket wheel 68 (FIG. 2) and a head drive sprocket wheel 70 best seen in FIG. 34.

Preferably, the rear sprocket wheel 68 is suspended from vertical frame supports 72, which in turn can be suspended from a ceiling or extend upward from a floor, within a floating sprocket carriage generally designated 74 at the head end 54 of the parcel sorting conveyor means 50. The drive sprocket wheel 70 (FIG. 34) and tail end 60 are also preferably supported by vertical frame supports not illustrated.

Extending from the vertical frame supports 72 forwardly in the direction of travel of the conveyor means 50 are two sets of horizontally spaced apart pairs of parallel supports 76 and 78. As can be seen from FIG. 3, there are a pair of these supports extending from each of the vertical frame supports 72. Mounted on the top of the upper supports 78 are inverted V-shaped, in cross section, tracks 80 of relatively short length.

The floating sprocket carriage generally designated 74 includes an upper frame member 82 and a lower frame member 84. Additionally, each of these frame members 82 and 84 are joined by cross members 86 and 88. Thus, there is formed between the respective members 82, 84, 86 and 88, a generally square frame structure. Journalled on a rotatable shaft 90 is the rear sprocket wheel 68. This shaft is preferably mounted in a pair of opposed bearings 92 and 94 best seen in FIG. 3. The bearings 92 and 94 are in turn secured to intermediate, generally horizontal support members 96 and 98 which in turn are secured to a front plate 100 to which the upper and lower frame members and cross members 82 through 88 are also secured by welding or other means. Thus the plate 100, square frame structure defined by members 82, 84, 86 and 88, shaft 90, and sprocket wheel 68 are integral and form the floating sprocket carriage 74.

Mounted on the exterior of the respective upper and lower frame members 82 and 84 are pairs of upper rear rollers 102 and 104 and pairs of lower forward rollers 106 and 108, respectively. As can be seen in the drawings, the rollers 102 and 104 are mounted on the tracks 80. It should be noted that the lower and upper spaced apart supports 76 and 78 are angled slightly above the horizontal so that the entire floating sprocket carriage 74 will be urged rearwardly toward the vertical support 72 in order to keep the necessary tension on the sprocket chain 66.

There is additionally preferably provided a tension cable 110 which extends from the carriage 74 rearwardly passing over a pulley 112 downwardly to a spool 114 where it is wound around the spool and then extends downwardly, terminating in a counterweight 116.

Thus it can be seen that with the tension cable 110 and the inclusion of the floating sprocket carriage 74, the sprocket wheel 68 will be continually urged to the left when looking at FIG. 2 so that the sprocket chain 66 is maintained with the appropriate amount of tension. Because of the configuration of the tension cable 110 and pulley 114, there is a certain amount of play that is available so that the sprocket wheel 68 may be moved forwardly to release tension where it is necessary to repair a portion of the parcel sorting conveyor means 50.

Referring now to FIG. 34, the tail end 60 of the conveyor means 50 includes a drive sprocket wheel 70 of similar configuration to the sprocket wheel 68. The sprocket wheel 70 is mounted on a shaft 118 and the shaft in turn is journalled in a pair of bearing members 120 which in turn are mounted on a pair of horizontal support members 122 and 124, tied to vertical supports 123 and 125.

The shaft 118 extends out beyond one of the bearing members 120 such as seen in FIGS. 36 and 37, where there is journalled a motor sprocket drive wheel 126. Extending around the motor sprocket wheel 126 is a motor sprocket chain 128 extending to and rotatable by, a drive motor 130. Between the drive motor and the sprocket chain 128, there are preferably included reduction gears within gear box 132.

Thus, when the motor 130 is actuated, the motor sprocket wheel 126 and in turn the drive sprocket wheel 70 will be rotated which in turn will move the sprocket chain 66 and in turn drive the rear sprocket wheel 68. With the movement of the sprocket chain 66, the receptacle means 62 and carriage units 64 will be moved in a vertical axial orbit from right to left as viewed in FIG. 2, from the bottom or inoperative position to the upper loading and operative position.

While there is not illustrated in the present embodiment an additional drive means, should it be desired that the parcel sorting conveyor means 50 move heavy parcels over an extremely long area, additional drive sprocket wheels and motors may be placed intermediate the respective ends without departing from the spirit of the invention.

GUIDE MEANS

Forming a part of the parcel sorting conveyor means 50 are guide means generally designated 134 or tracks upon which carriage units 64 ride. There are on each side of the conveyor means 50, pairs of upper guide tracks 136 and lower guide tracks 138 which are vertically spaced apart and parallel with each other. Each track 136 and 138 extends from a position on a vertical line with the axis of the sprocket wheel 68 as illustrated in FIG. 2, to a position on a vertical line with the axis of the drive sprocket wheel 70 as illustrated in FIG. 34. The configuration of the respective guide tracks 136 and 138 are channel shaped so that there is a riding surface 140 on the upper guide track 136 and a riding surface 142 on the lower guide track 138.

The guide means 134 also includes spaced between one of the pairs of upper guide tracks 136 and lower guide tracks 138, an endless generally elliptically shaped reset track 144 (FIG. 8). The reset track 144 is preferably channel shaped similar to the guide tracks 136 and 138. FIGS. 5, 6 and 8 illustrate the relative vertical positioning between the respective guide tracks 136 and 138 and the reset track 144.

Each of the respective carriage units 64 are positioned so as to be movably mounted within the guide tracks 136 and the reset tracks 144 to be hereinafter discussed in detail.

CARRIAGE UNITS

As can be seen from several of the drawings, there are a plurality of carriage units 64 forming a part of the receptacle means 62 which are contiguous and secured to the endless drive chain 66, around the entire periphery of the drive chain 66.

A carriage unit 64 is best seen in FIG. 6 through 10. As previously described, the receptacle means 62 preferably comprises a dished shaped tray 63 which is secured to a carriage unit 64 and adapted to receive parcels or items for conveying and sorting. While preferably the trays 63 are dished shaped, any type of platform may be utilized without departing from the spirit of the invention.

The carriage unit 64 includes a generally U-shaped frame 147 having a forward vertical wall 148 and a rear vertical wall 150 joined together by a horizontal bottom wall 152. There is extending downward from the bottom wall 152, a pair of dogs 154 which are secured to drive chain extensions 156. Thus, with the movement of the drive chain 66, the U-shaped frame 147 will also be moved along the direction of travel. The frame 147 can be cast of metal or formed in any other well known manner.

Extending outwardly from the respective vertical walls 148 and 150 in opposed directions, as best seen in FIG. 8, are guide roller shafts 158 on which are rotatably mounted, guide rollers 160. As can be seen from FIG. 8, these guide rollers 160 are positioned within the upper guide tracks or lower guide tracks 136 or 138 depending on the position of a particular carriage unit 64, so that the rollers 160 may ride either on the upper riding surface 140 of the upper guide track 136 or the riding surface 142 of the lower guide track 138.

Extending between the respective vertical walls 148 and 150 is a horizontal support bar 162 which includes a bifurcated end section 164 (FIG. 10) having arms 166 and 168 with a guide roller 170 mounted on a shaft 172 so that the guide roller 170 may bear against the respective guide tracks 136 and 148 to assure proper lateral or horizontal alignment of the carriage units 64.

The trays 63 include a pair of downwardly extending, spaced apart mounting blocks 174 which are pivotally mounted to the upper end of the respective vertical walls 148 and 150 by means of pivot pins 176. There is also included around extensions of the shafts 176 as best seen in FIG. 6, torsion springs 178 which assist in maintaining the receptacle or trays 62 in horizontal position such as shown in FIG. 6. In the horizontal position, or parcel receiving position, parcels may be loaded onto the trays and transported to a desired location. At that point, by means to be described, the trays 63 may be tilted to the right such as seen in phantom in FIG. 8 or to the left as is seen in FIG. 9, whereby the parcels may be discharged by gravity in either direction.

In order to move the respective trays 63 from the horizontal to a tilted position, previously described, there is included within the carriage units 64, actuator means 180.

The actuator means 180 includes an actuator arm 182 which is pivotally mounted at one end to the forward vertical wall 148 by means of pivot pin 184 extending from the vertical wall 148 through said actuator arm (FIGS. 6 and 7). The arm 182 in a normal position extends rearwardly parallel with wall 152. At the opposite end of arm 182 there is pivotally mounted a reset roller 186 by means of pivot shaft 188.

In between a portion of the respective ends of the actuator arm 182 there is an opening 189 in which is pivotally mounted one end of an actuator rod 190 by means of an actuator rod pivot pin 192. The rod 190 extends vertically upward as best seen in FIG. 6 and 8 to a point adjacent the forward mounting block 174 secured to wall 148 where it is pivotally secured thereto by means of a bolt 194.

In the normal horizontal position such as illustrated in FIG. 6, the reset roller 186 is mounted in the reset track 144 which runs parallel with and spaced from the guide track 136. When it is desired to tilt the tray 63 either to the right or to the left of the line of travel, it is necessary for the reset rollers 186 to be moved from the reset track 144 to an upper left-hand track 196 or a lower right-hand track 198. By so moving the reset roller 186 to a plane above or below the reset track 144, the actuator arm 182 will pivot on the pin 184 upward or downward in a vertical plane, thus causing the actuator rod 190 to move upward or downward either forcing the tray, if downward, to a position to the right of the line of travel, as seen in FIG. 8, or if the rod 190 is pushed upwardly, the tray 63 will be pivoted to the left as is seen in FIG. 9.

To illustrate the above description of the tilting, there is seen in FIG. 8 in phantom line below the reset track 144, a right-hand track 198 and the position of the reset roller 186 in a lower plane than the reset track 144, which causes the tray 63 to tip to the right.

DEFLECTOR MECHANISM

As can be seen from the drawings and from this description, it is not necessary that there be right- or left-handed tracks 196 or 198 that extend around the entire periphery of the conveyor. Alluding to FIG. 1, it can be seen that it is only necessary that there be sections of right- or left-hand deflector tracks 196 and 198 in the vicinity of the lower or sub-conveyors 56 to achieve the appropriate tilting of the trays 62 for discharge of items onto these lower sub-conveyors 56.

FIGS. 11 through 19 illustrate various configurations of reset, right- and left-hand deflector tracks and their relative arrangement to each other which may be used to accomplish the desired result. These positions are by way of illustration and not limitation.

In order to move the reset roller 186 from one track to another, it is necessary that deflection means 200 be used. The deflection means, as schematically illustrated in FIGS. 11 through 19 are in effect, pivoted ramps upon which the reset rollers 186 may ride. In FIG. 11, there is illustrated the normal position or straight position where the reset rollers 186 would ride in the reset track 144 and of course the guide rollers 160 continue to ride in the guide track 136.

FIG. 12 illustrates the deflector means 200 pivoted downward to allow the trays 62 to be deflected or tilted to the right by passing from the reset track 144, down the deflector means 200 onto the lower right-hand track 198. FIG. 13 illustrates the position of a deflector means 200' whereby the reset roller will move from the reset guide 144 to the upper or left-hand track therefor causing the tray to tilt to the left.

FIGS. 14 and 16 illustrate the deflector means 200 or 200' which will allow the reset roller to move from one track, either right or left, to the reset position and then back to the right or to the left.

While only deflector means 200 and 200' are illustrated as single position deflector means to pivot for a left side tilt of the trays 62 or to pivot for a right side tilt of the trays 62, respectively, it is recognized that a universal deflector means may be provided that can be pivoted either downward or upward from a normal horizontal at rest position.

The deflector means 200 and 200' illustrated in FIGS. 20 and 27 may be actuated for movement by control means operable from a console (not illustrated) on the loading platform 52 or upon command from an electronic memory source.

Referring to the deflector 200 illustrated in FIG. 20 and for convenience identified generally as the left-hand deflector means, the reset track 144 is cut and a portion removed so that there is a rear end 204 and forward end 206 of the track 144 at that spot. Intermediate the respective ends 204 and 206, there is positioned a deflector track section 208 having a channel shaped configuration similar to the reset track 144. The deflector track section 208 includes an outwardly extend-

ing set collar 210 fitted with a set screw 211. Projecting from end 204 of reset track 144 is a vertical bracket 212 forming one of the vertical braces for the conveyor system. Welded or otherwise secured to the bracket 212 is a bearing collar 214 (FIGS. 20 and 21) aligned with said collar 210. Inserted through bearing collar 214 and into set collar 210 is a pivot shaft 216. Secured around the outer extremity of the shaft 216 is a second set collar 218 having a set screw 219 inserted therein. Positioned between the set collars 210, 218 and the bearing collar 214 are washers 220. Thus when the set screws 211 and 219 are tightened on the shaft 216 the entire deflector track section 208 may pivot in the fixed bearing collar 214.

Normally, the deflector track section 208 is in a horizontal position such as seen in FIG. 20 so that the reset rollers 186 may continue on a horizontal line. Thus, the trays or receptacles 62 will remain horizontal. However, when it is desired to tilt the receptacle 62 to the left of the line of travel for discharge of parcels thereon, apparatus is included with the left-hand deflector means 200 to pivot the deflector track section 208 upward from the solid line position shown in FIG. 20 to the phantom position so that the roller 186 may move from the reset track 144 to the upper left-hand track 196 illustrated in FIG. 13.

In order to accomplish the pivoting from the normal horizontal to the upward angular position in FIG. 20, there is provided a wedge or cam race assembly 221' including an intermediate wedge 221 (FIG. 21) mounted on a bracket 222 secured to track section 208. The wedge 221 has a sloping camming surface 224. Mounted beneath the camming surface 224 and spaced therefrom in parallel relationship is a rail 225 secured to the wedge 221 by spacers 226. Mounted on a deflector base plate 227 are a pair of spaced apart inner and outer wedges 228 and 229 respectively. These wedges 228 and 229 have camming surfaces 230 which are reverse angles from the camming surface 224 and as can be seen in FIGS. 21 and 21a the wedge 221 is vertically aligned intermediate the wedges 228 and 229. Each wedge 228 and 229 includes spaced from the camming surfaces 230, rails 231 of similar dimension with rail 225, which are secured to the wedges 228 and 229 by spacers 232.

Mounted rearwardly of the wedge assembly 221' on the deflector base 227 is a deflector actuator means 234 preferably comprising a pneumatic cylinder 236 pivotally secured to a pivot support 238. Extending outwardly at the front of the pneumatic cylinder 236 is a plunger 240 which includes a bearing collar 241 at the extreme end thereof. Journalled in the collar 241 is a roller shaft 242 having a pair of opposed cam rollers 243 mounted thereon. Extending upwardly from the shaft 242 are a pair of spacer plates 244 (FIG. 21a) with an intermediate cam roller 245 rotatably mounted therebetween on a shaft 246.

The cam roller 245 is mounted between camming surface 224 and rail 225, while the cam rollers 243 are mounted between the camming surfaces 230 and rails 231.

As the pneumatic cylinder 236 is activated and the plunger 240 urged forwardly, the cam rollers 243 will travel upwardly on the camming surfaces 230 and the cam roller 245 being connected to the cam rollers 243 will be urged against the camming surface 224 creating a positive pivot movement to the track section 208 to the phantom position illustrated in FIG. 20. When the section 208 is to be returned the plunger 240 is drawn inwardly and the rail and cam roller arrangement will insure a positive downward movement of the section 208 to its normal at rest horizontal position.

Any well known type of connections may be utilized with the air pneumatic cylinder 236 to move the plunger 240, such as an inlet line 246 and an exhaust line 248 each of which may extend from the cylinder 236 to a four-way solenoid valve 250 which controls the air supply moving through the master air line 252. Additionally, a muffler 251 may be attached to the valve 250 to deaden the sound of air being expelled through the valve 250.

Referring now to the deflector 200' identified as the right-hand deflector illustrated in FIG. 27, the construction and elements of said right-hand deflector 200' are identical with the left-hand deflector 200.

Because the elements of the right-hand deflector 200' and the left-hand deflector 200 are identical, identical prime numbers will be used with regard to the right-hand deflector 200'. The reset track 144 is cut forming a rear end 204' and forward end 206'. Intermediate the respective ends 204' and 206' there is positioned a deflector track section 208' having a channel shaped configuration, see FIG. 28 similar to the reset track 144. The deflector track section 208' includes an outwardly extending set collar 210' (FIG. 28) fitted with a set screw 211'. Projecting from end 204' of reset track 144 is a vertical bracket 212' forming one of the vertical braces for the conveyor system. Welded or otherwise secured to the bracket 212' is a bearing collar 214' (FIG. 28) aligned with said collar 210'. Inserted through bearing collar 214' and into set collar 210' is a pivot shaft 216'. Secured around the outer extremity of the shaft 216' is a second set collar 218' having a set screw 219' inserted therein. Positioned between the set collars 210', 218' and the bearing collar 214' are washers 220'. Thus when the set screws 211' and 219' are tightened on the shaft 216' the entire deflector track section 208' may pivot in the fixed bearing collar 214'.

Normally, the deflector track section 208' is in a horizontal position such as is shown in FIG. 27 so that the reset rollers 186 may continue on a horizontal line. Thus, the trays or receptacles 62 will remain horizontal, when it is desired to tilt the receptacle 62 to the right of the line of travel for discharge of parcels thereon, apparatus is included with the right-hand deflector means 200' to pivot the deflector track section 208' from the solid line position shown in FIG. 27 to the phantom position so that the roller 186 may move from the reset track 144 to the lower right-hand track 198 illustrated in FIG. 12.

In order to accomplish pivoting from the normal horizontal to the downward angular position reflected in phantom lines in FIG. 27, there is provided a wedge assembly 221'' including an intermediate wedge 221' (FIG. 27) mounted on a bracket 222' secured to track section 208'. The wedge 221' has a sloping camming surface 224'. Mounted beneath the camming surface 224' and spaced therefrom in parallel relationship is a rail 225' secured to the wedge 221' by spacers 226'. Mounted on a deflector base plate 227 are a pair of spaced apart inner and outer wedges 228 and 229 respectively. These wedges 228' and 229' have camming surfaces 230' which are reverse angles from the camming surface 224' and as can be seen in FIGS. 27 and 28a the wedge 221' is vertically aligned intermediate the wedges 228' and 229'. Each wedge 228' and 229' includes, spaced from the camming surfaces 230', rails 231' of similar dimension with rail 225, which are secured to the wedges 228' and 229' by spacers 232'.

An actuator means 234' is mounted on the deflector base 227' and comprises a pneumatic cylinder 236' pivotally secured to pivot support 238'. Extending outwardly at the front of the pneumatic cylinder 236' is a plunger 240' which includes a bearing collar 241' is a roller shaft 242' having a pair of opposed cam rollers 243' mounted thereon. Extending upwardly from the shaft 242' are a pair of spacer plates 244' (FIG. 28a) with an intermediate cam roller 245' rotatably mounted therebetween on a shaft 246'.

The cam roller 245' is mounted between camming surface 224' and rail 225', while the cam rollers 243' are mounted between the camming surfaces 230' and rails 231'.

When it is desired to move the section 208' to the position as shown in phantom line, the pneumatic cylinder 236' is activated and the air expelled so that the plunger is retracted and the cam rollers 243' will travel downwardly on the camming surfaces 230' and the cam roller 245' being connected to the cam rollers 243' will be urged against the rail 225' creating a positive pivot movement to the track section 208'. When the section 208' is to be returned to plunger 240' is urged outwardly and the rail and cam roller arrangement will insure a

positive downward movement of the section 208' to its normal at rest horizontal position.

Again, as with the left-hand deflector 202, any well known type of connections may be utilized with the pneumatic cylinder 236' to move the plunger 240' such as an inlet line 246' and an exhaust line 248' each of which may extend from the cylinder 236' to a four-way solenoid valve 250' which controls the air supply moving through the master airline 252'. Additionally, there may be secured to the solenoid 250', a muffler 251' to silence the outrush of the air through the exhaust line 248'.

COUNTERBALANCE DEFLECTOR MEANS

FIGS. 22 through 26 and 29 through 33 illustrate left- and right-hand counterbalance deflector means 268 and 270 respectively. The left-hand counterbalance deflector means is illustrated in FIGS. 22 through 26 and the right-hand counterbalance deflector means 270 is illustrated in FIGS. 29 through 33.

When the reset rollers 186 of the respective carriage units 64 are traveling in the left-hand deflector track 196, it is necessary that appropriate mechanism be utilized to allow the reset rollers 186 to move from the left-hand track 196 back to the reset track 144 whereby the trays 63 will return to a horizontal position ready to receive additional parcels or items.

In order to accomplish this reset from the left-hand track 196 to the reset track 144, the left counter balance deflector means 268 is employed. It should be understood that the counterbalance deflector means 268 and 270 is not controlled by any exterior means but utilizes the principle of gravity to allow the rollers 186 to move from the upper track to the reset or from the lower track to the reset track.

As can be seen in FIG. 22, there is angularly fixedly mounted in the left-hand deflector track 196, a deflector plate 272 which will be engaged by the reset rollers 186 and deflect or force the reset rollers 186 downward. Positioned below the plate 272 is a pivotably mounted gate ramp 274, which will move downward to the position such as shown in FIG. 23 to allow the reset roller 186 to move to the reset track 144. The gate 274 includes at one end a pivot pin collar 275 which is adapted to receive an outwardly extending pivot pin 276. This pin is mounted in a pivot bearing 278 which is secured to a support plate 280, which in turn is welded or otherwise secured to the reset track 144 as best seen in FIG. 25.

In order to lock the pivot pin 276 within the arm 275, there is a locking pin 281 (FIG. 26).

Secured to the exterior end of the pivot pin 276 by means of a locking pin 283, is a counterweight bracket 282 fitted to pivot with the pin and the ramp gate 274. Secured rearwardly of the ramp gate 274 to the counterweight bracket 282 is a threaded counterweight shaft 284. Threadably or loosely secured on the shaft 284 is a counterweight 286. The counterweight 286 is shiftable along the threaded shaft 284 to assure the proper quick return of the ramp gate 274 to the horizontal position such as is illustrated in FIG. 22, once the reset rollers 186 have passed down the ramp gate into reset track 144. In order to fix the counterweight 286 on the threaded shaft 284 a pair of lock nuts 288 are provided.

The deflector means 270 further identified as the right-hand counterbalance deflector means illustrated in FIGS. 29 through 32 is of a similar construction to the left-hand counterbalance deflector means 268 and includes the same elements but arranged to allow the reset rollers 186 to move from the right-hand track 198 upward to the reset track 144.

There is provided an elongated ramp gate 290 including a pivot arm 292 and a pivot shaft 294 secured within the arm 292 by means of locking pin 296. The shaft 294 is journaled in a pivot bearing 298 which in turn is secured to a support plate 300 which in turn is secured by welding or other means to the reset track 144.

Journalled on the pivot shaft 294 is a counterweight bracket 302 by means of a locking pin 304. Secured to the counterweight bracket 302 is a threaded counterweight shaft 306 upon which is mounted a counterweight 308 which will assure the return of the gate 290 from the position such as shown in FIG. 30 where it has been engaged by the roller 186 traveling upward on the fixed ramp 309 interposed in the right-hand deflector track 198. Its normal horizontal position is such as shown in FIG. 29 whereby the rollers that are moving along the reset track 144 may move across the top of the ramp gate 290 to continue uninterrupted. The counterweight 308 is secured to the shaft 306 by means of lock nuts 310.

OPERATION

When the parcel sorting conveyor means 50 is activated through the motor 130, it will move in a direction as seen by the arrows in FIG. 1, away from the loading platform 52. Because of the fact that the conveyor is an endless conveyor system, individual receptacle or parcel trays 62 will be presented to the loading platform 52 and may be loaded with desired parcels.

Normally, the receptacle trays 62 are in a horizontal position and when it is desired to remove the parcels from the trays either to the right or to the left of the line of travel of the conveyor, the trays 62 are tilted by means of the actuator means 180 moving from the normal reset track 144 to an upper left-hand deflector track 196 or lower right-hand deflector track 198 through the actuation of either the left- or right-hand deflectors 200 or 200' so that gravity will discharge the parcels to either a sub-conveyor 56 or another platform as desired.

Once the receptacles or trays 62 have been tilted, it is necessary to right the receptacle to the normal horizontal position which may be accomplished through movement of the reset roller which is part of the actuator mechanism 180 back to the reset track 144. Such movement may be accomplished through the counterweight left-hand or right-hand means generally designated 268 or 270.

As described before, the guide tracks 136 and 138 are parallel and in vertical alignment, and it is not necessary that they be tied together around the end curves of the conveyor 50. As the carriage units 64 pass from the track 136 around the end of the conveyor means 50, they will remain in relative alignment due to the sprocket chain 146 engaging the sprocket wheels 70. Each of the carriage units 64 will then engage the lower guide track 138 and move to the end of the conveyor means 68 and will re-engage the upper guide track 136 when each of the carriage units 64 assume a generally horizontal position (see FIG. 1).

Although I have herein shown and described my invention in what I have conceived to be the most practical and preferred embodiment, it is recognized that departures may be made therefrom within the scope of my invention.

What is claimed is:

1. An endless conveyor means adapted to receive and move parcels therealong and selectively discharge said parcels normal to the line of travel of said conveyor means comprising: an endless drive means; motor means associated with said drive means and adapted to be energized to move said endless drive means; a plurality of contiguous parcel receptacle means each having a portion fixed to said endless drive means, and a tiltable parcel receiving portion pivotally mounted thereon normally riding in a horizontal position relative to the line of travel; guide means paralleling said endless drive means and spaced therefrom, said guide means engageable by said portion of said parcel receptacle means fixed to said endless drive means whereby said portion is stabilized during movement; reset means positioned generally parallel with said guide means; actuator means riding in said reset means and secured to said parcel receiving portion of said receptacle means; single direction deflecting means selectively positioned in said reset means adapted to vertically shift said actuator means and

pivot said parcel receiving portion in said desired direction normal to the line of travel whereby a parcel thereon will be gravitationally discharged therefrom and further vertically shift said actuator means to return said parcel receiving portion to said generally horizontal position after said discharge wherein said single direction deflecting means includes gates positioned in said reset means which normally are stabilized in a horizontal position to form a continuation of said reset means but which may be moved from said horizontal position in a vertical plane relative thereto to effect a tilting of said parcel receiving portion and return to said horizontal position relative to the line of travel.

2. An endless conveyor means as defined in claim 1 wherein said single direction deflecting means adapted to vertically shift said actuator means returning said parcel receiving portion to said generally horizontal position includes a ramp communicable with said reset means and wherein said ramp is pivotable and includes a counterweight to maintain said ramp in a horizontal position; said ramp adapted to yieldably pivot when said counterweight is momentarily overcome by the weight of said actuator means to engage said reset means and cause the vertical shifting of said actuator means.

3. An endless conveyor means as defined in claim 1 wherein said gates include deflector actuator means which may be selectively energized to effect movement of said gates.

4. An endless conveyor means as defined in claim 1 wherein said actuator means includes an actuator arm pivotally connected to said portion of said parcel receptacle means fixed to said endless drive means and a roller mounted on said arm remote from said pivotal connection riding in said reset means and a connecting rod extending between said parcel receiving portion and said actuator arm.

5. An endless parcel sorting conveyor system adapted to receive and move parcels normal to the line of travel of said system comprising: a frame, a plurality of contiguous parcel receptacle means movably mounted on said frame, and each of said receptacle means including a parcel receiving portion pivotally mounted thereon and independently tiltable with respect to another parcel receiving portion, said parcel receiving portion normally riding in a horizontal position relative to the line of travel; an endless drive means including motor means to energize said drive means, and each of said parcel receptacle means fixed to said drive means for movement; guide means on said frame paralleling said endless drive means, and engageable by said receptacle means whereby said receptacle means is stabilized during movement, reset track means on said frame generally parallel with said guide means; actuator tie means secured to and extending from said parcel receiving portion outwardly of said pivot and having a portion riding in said reset track means whereby said parcel receiving portion remains horizontal; deflecting means selectively positioned in said reset means and adapted to interrupt said reset track means and upon engagement, channel said actuator tie means portion riding in said reset track means above or below said reset track means causing said actuator tie means to shift vertically and tyingly impart direct pivoting of said parcel receiving means normal to the line of travel whereby a parcel thereon will be gravitationally discharged, and maintaining said means in said tiltable condition, and another deflecting means adapted to return said actuator tie means portion back to said reset track means and vertically shift said actuator tie means and tyingly pivot said parcel receiving portion to said generally horizontal position.

6. A parcel sorting conveyor adapted to receive parcels and convey them to a selected position where they are discharged from said conveyor comprising: an endless drive means; motor means connected to said endless drive means and adapted to be energized to move said endless drive means; a plurality of contiguous parcel receptacle means each having a carriage assembly including guide wheels, said assembly being fixed to said endless drive means and a parcel receiving tray pivotally mounted on said carriage assembly riding generally horizontal yet adapted to be tilted to either side of the line of travel;

guide track means mounted parallel to and vertically spaced from at least a portion of said endless drive means, and said guide wheels engageable with said guide track whereby the movement of said carriage assembly is stabilized; reset track means mounted parallel to said guide track means and adapted to cooperatively maintain said tray generally horizontal; actuator means riding in said reset track means and secured to said parcel receiving tray; single direction deflecting means selectively positioned in said reset track means adapted to be activated to vertically shift said actuator means and pivot said parcel receiving tray from the horizontal in said single direction normal to the line of travel whereby a parcel thereon will be gravitationally discharged therefrom, and counterbalance deflector means adapted to vertically shift said actuator means to said reset means to return said tray to said generally horizontal position.

7. A parcel sorting conveyor as defined in claim 6 wherein said actuator means is secured to said tray outward of said pivotal connection of said tray to said carriage assembly.

8. A parcel sorting conveyor as defined in claim 6 wherein said single direction deflecting means includes at least one pivotable gate formed in said reset track means adapted to be pivoted vertically upward interrupting said reset track; a left-hand track section mounted above said reset track; said gate when pivoted upward mating with said left-hand track causing said actuator means to be moved vertically upward tilting said tray to the left of the line of travel, and said gate being returnable to continue said reset track upon passage therethrough of said actuator means.

9. A parcel sorting conveyor as defined in claim 6 wherein said single direction deflecting means includes at least one pivotable gate formed in said reset track adapted to be pivoted vertically downward interrupting said reset track; a right-hand track section mounted below said reset track; said gate when pivoted downwardly mating with said right-hand track causing said actuator means to be moved vertically downward tilting said tray to the right of the line of travel, and said gate being returnable to continue said reset track upon passage therethrough of said actuator means.

10. A parcel sorting conveyor as defined in claim 8 wherein said counterbalance deflecting means includes a pivotally mounted yieldable ramp in said left-hand track section including a counterweight to maintain said ramp as a continuation of said left-hand track section, said ramp being yieldable when said counterweight is momentarily overcome by the weight of said actuator means thereby causing said ramp to pivot downwardly and engage said reset track causing said actuator means to vertically shift downward and return said tray to said generally horizontal position.

11. A parcel sorting conveyor as defined in claim 8 wherein said counterbalance deflecting means includes a fixed ramp extending upward between said right-hand track section and said reset track means, a pivotally mounted yieldable ramp formed in said reset track above said fixed ramp including a counterweight maintaining said pivotally mounted ramp in a horizontal position; said actuator means engaging said fixed ramp and in turn engaging said pivotally mounted ramp pivoting the same upwardly allowing said actuator means to move into said reset means and the same vertically shift upwardly to return said tray to said generally horizontal position.

12. A parcel sorting conveyor as defined in claim 6 wherein said single direction deflector means are each activated for movement by a deflector actuator which includes a plunger united with said single direction deflector means adapted to stroke outwardly or inwardly in the alternative to effect movement of said single direction deflector means.

13. A parcel sorting conveyor as defined in claim 12 wherein said plunger is united with said single direction deflector means by a cam race assembly.

14. A parcel sorting conveyor as defined in claim 6 wherein said actuator means includes an actuator arm pivotally connected to said carriage assembly and a roller mounted on said arm remote from said pivotal connection; said roller riding in

said reset track means and a connecting rod extending between said tray and said actuator arm.

* * * * *

5
10
15
20
25
30
35
40
45
50
55
60
65
70
75