

Sept. 22, 1970

M. L. THORPE ET AL
INDUCTION PLASMA GENERATOR HAVING IMPROVED
CHAMBER STRUCTURE AND CONTROL

3,530,334

Filed Sept. 14, 1967

3 Sheets-Sheet 1

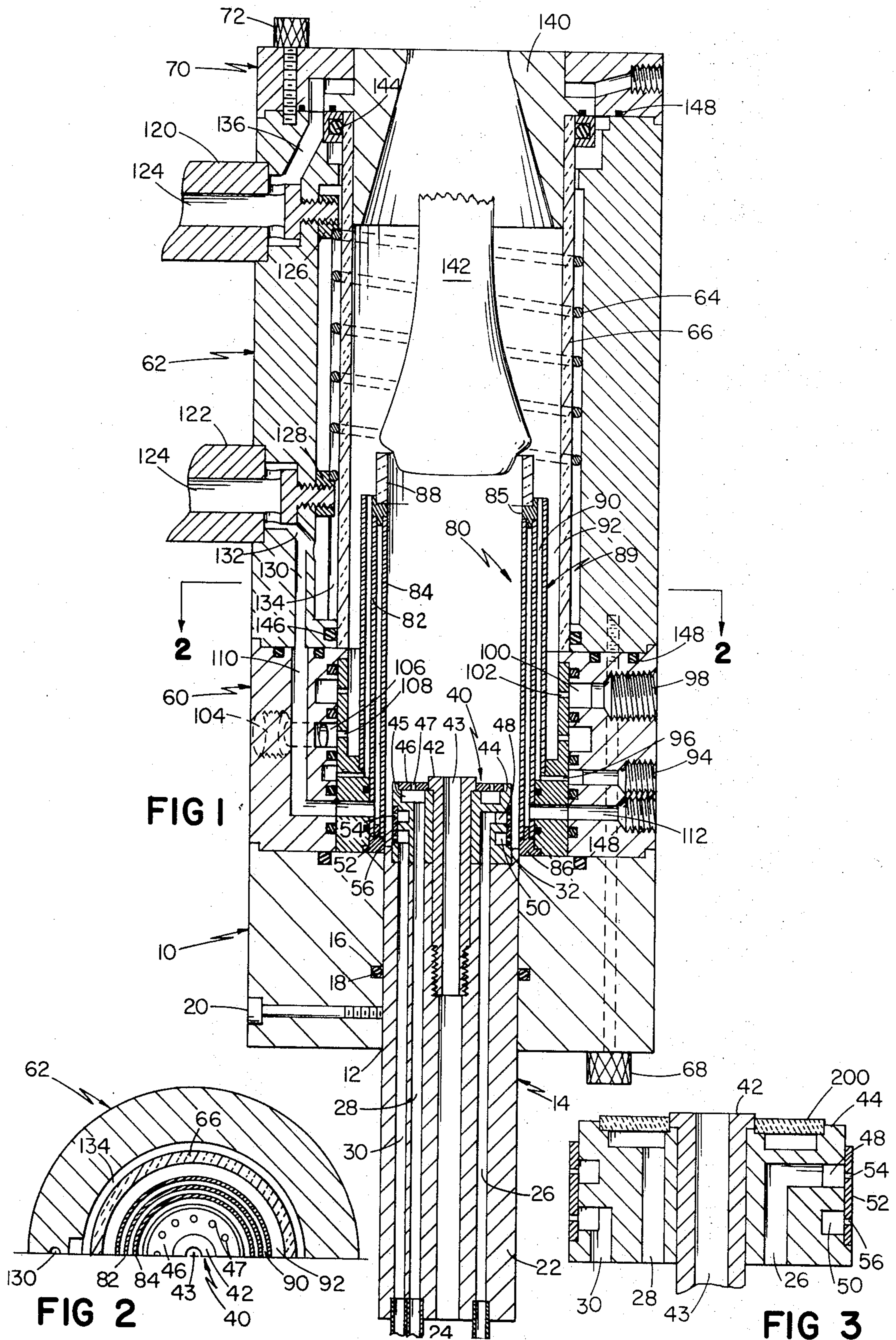

Sept. 22, 1970

M. L. THORPE ET AL
INDUCTION PLASMA GENERATOR HAVING IMPROVED
CHAMBER STRUCTURE AND CONTROL

3,530,334

Filed Sept. 14, 1967

3 Sheets-Sheet 2

FIG 5

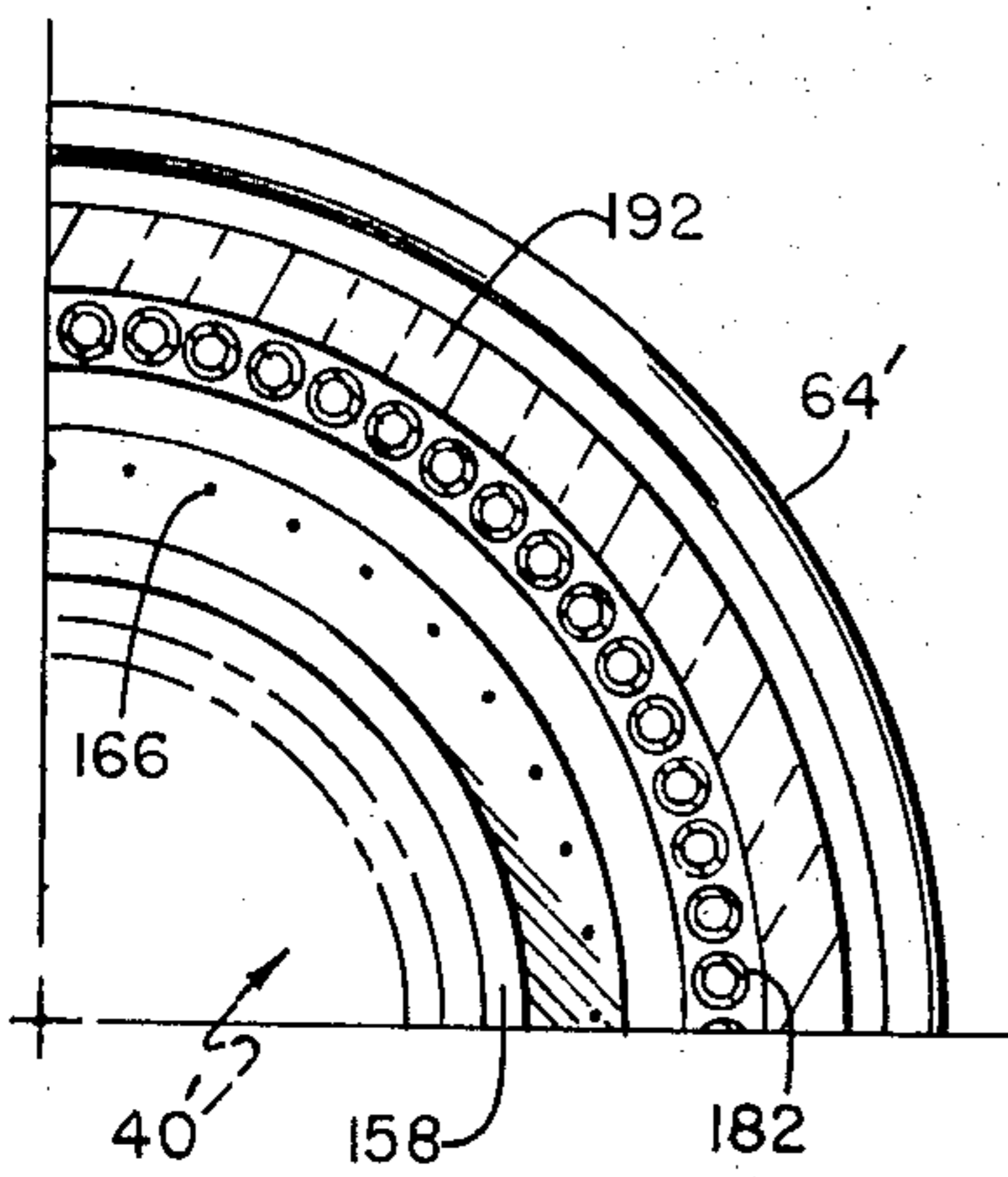
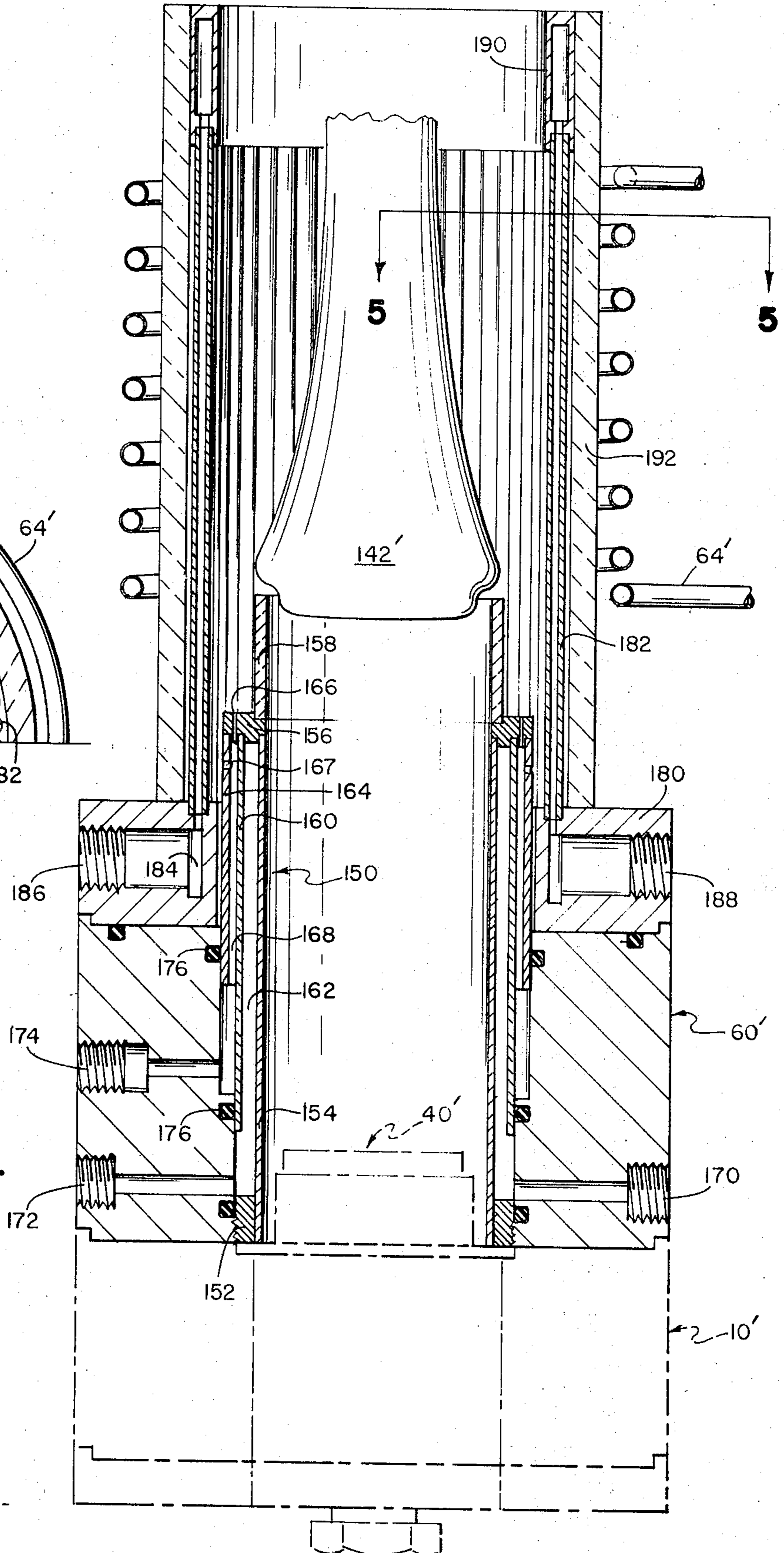

FIG 4



Sept. 22, 1970

M. L. THORPE ET AL
INDUCTION PLASMA GENERATOR HAVING IMPROVED
CHAMBER STRUCTURE AND CONTROL

3,530,334

Filed Sept. 14, 1967

3 Sheets-Sheet 3

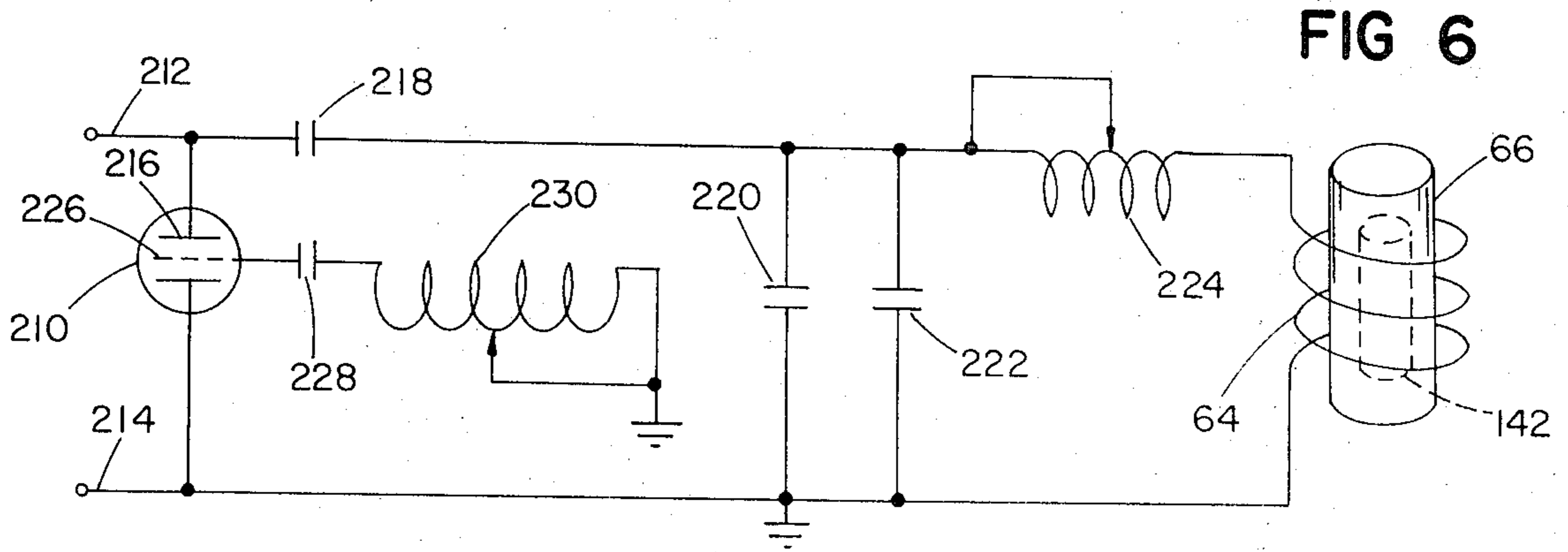

FIG 6

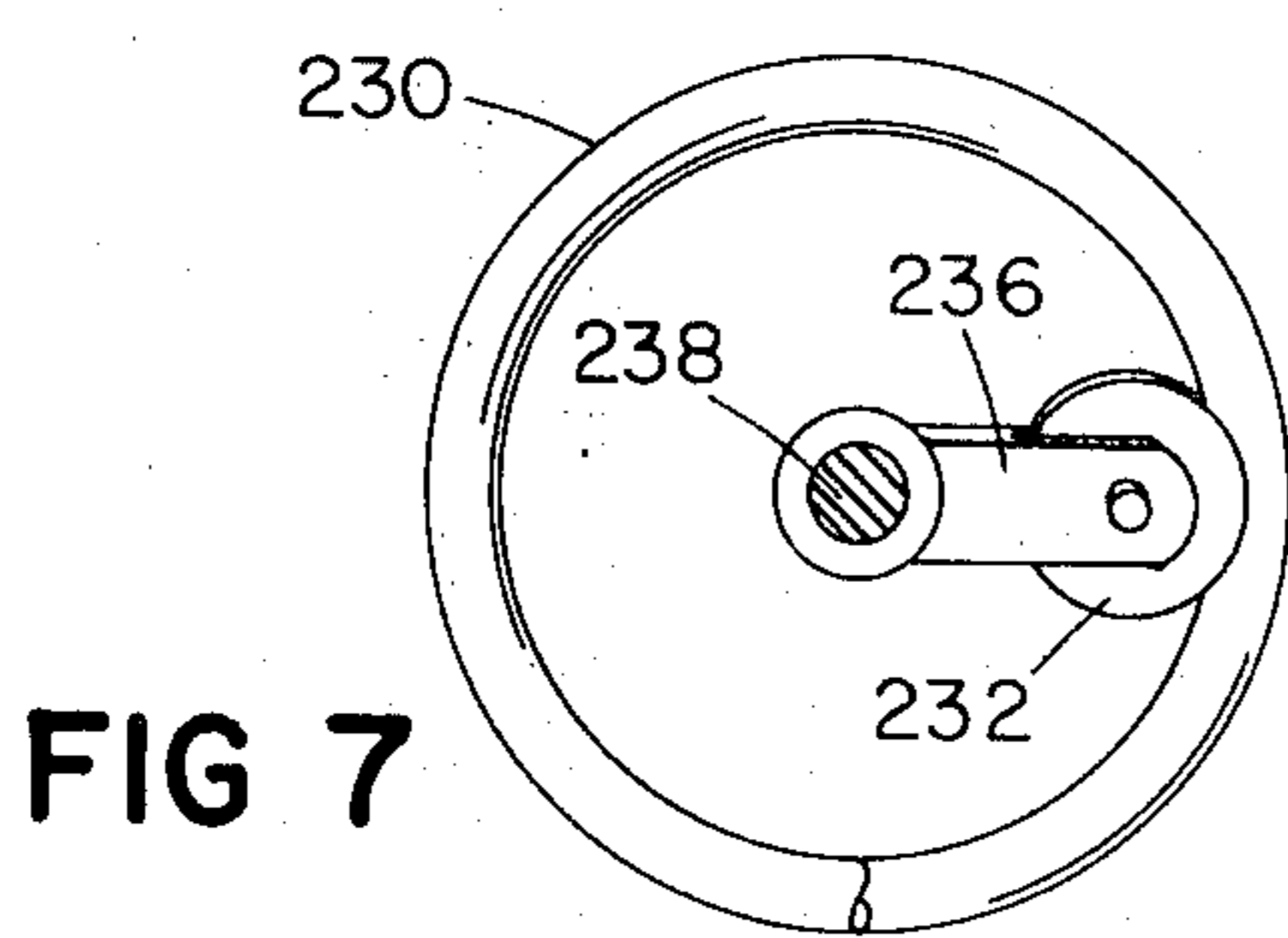

FIG 7

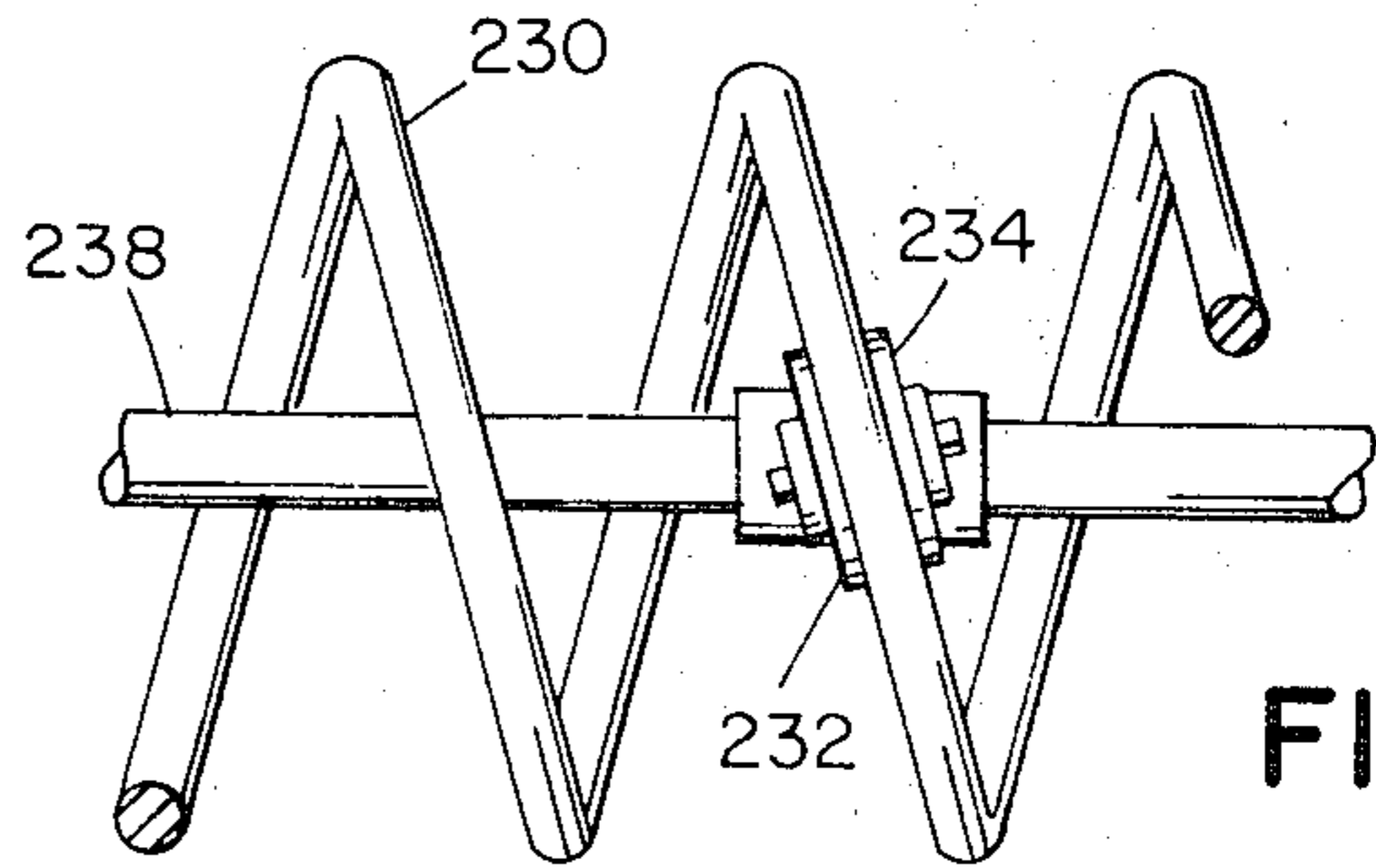

FIG 8

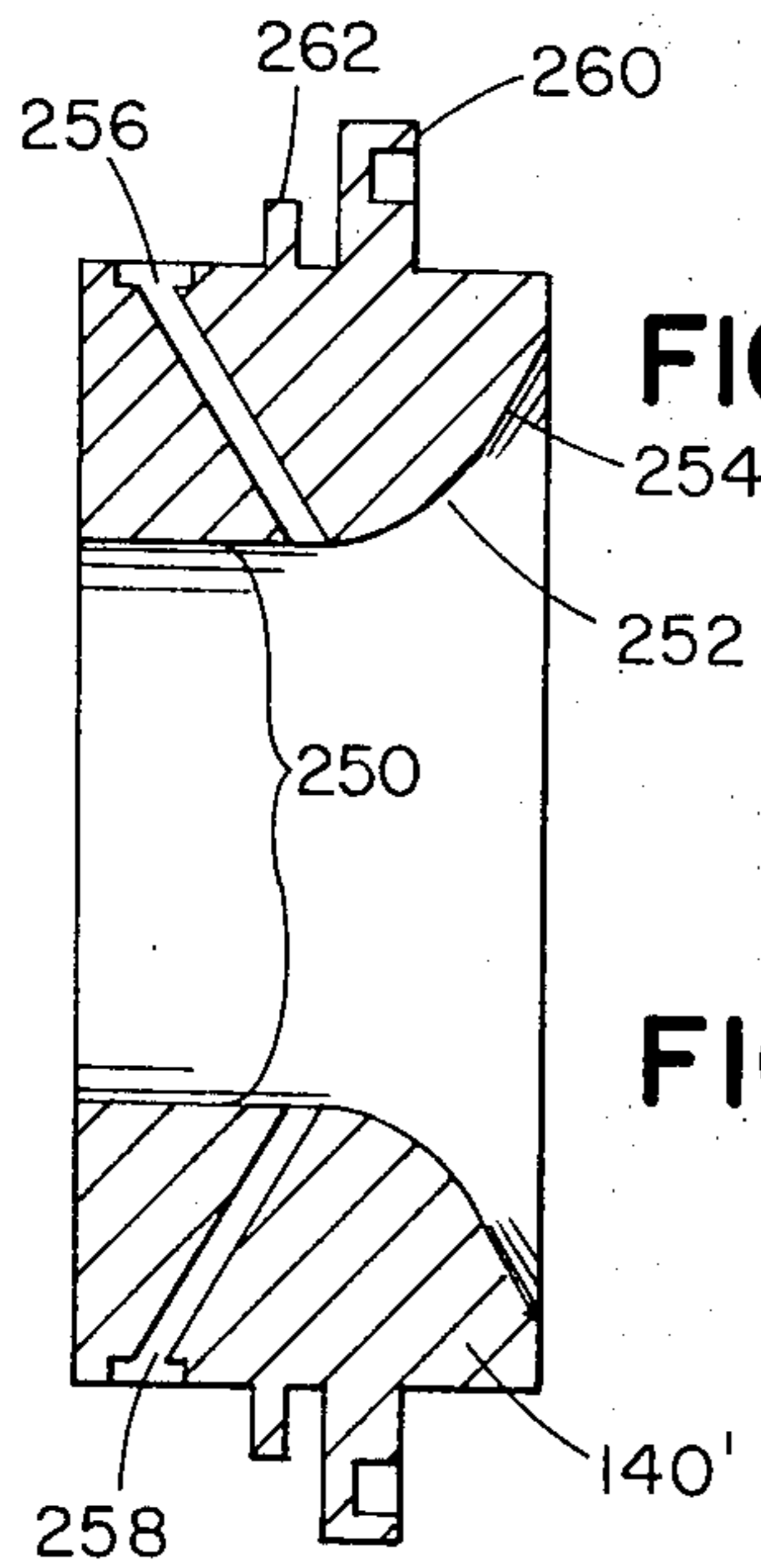

FIG 10

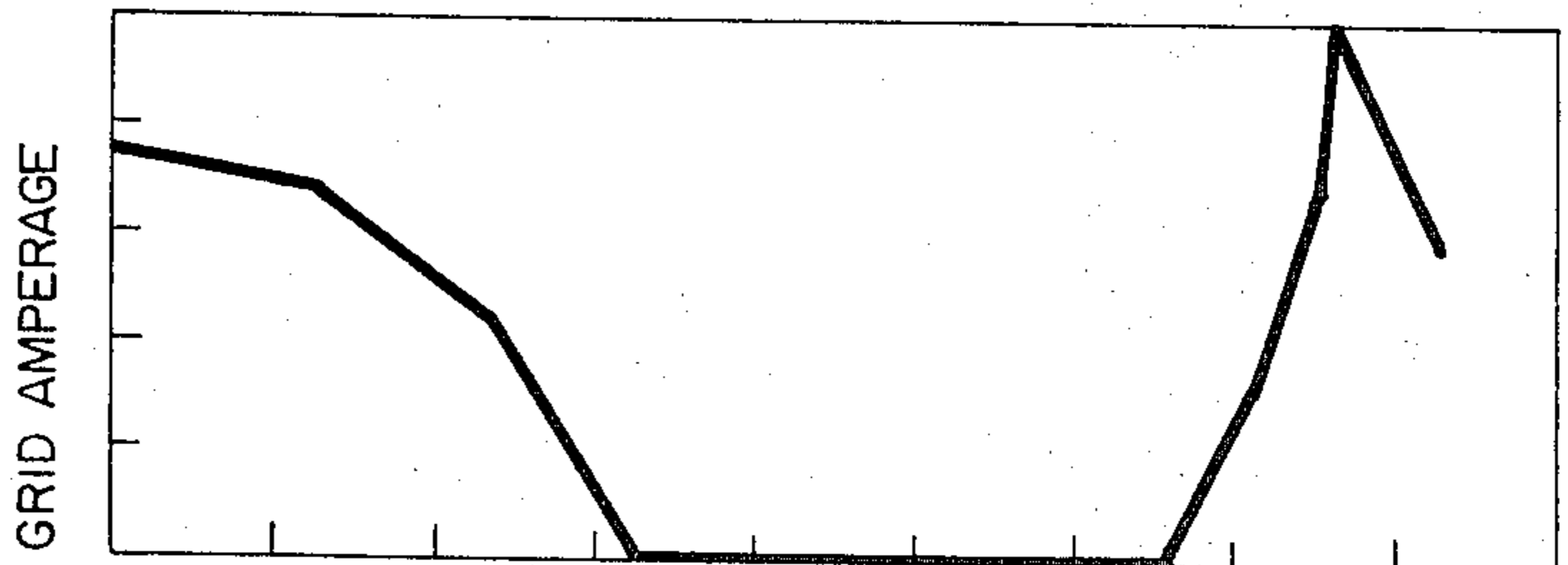
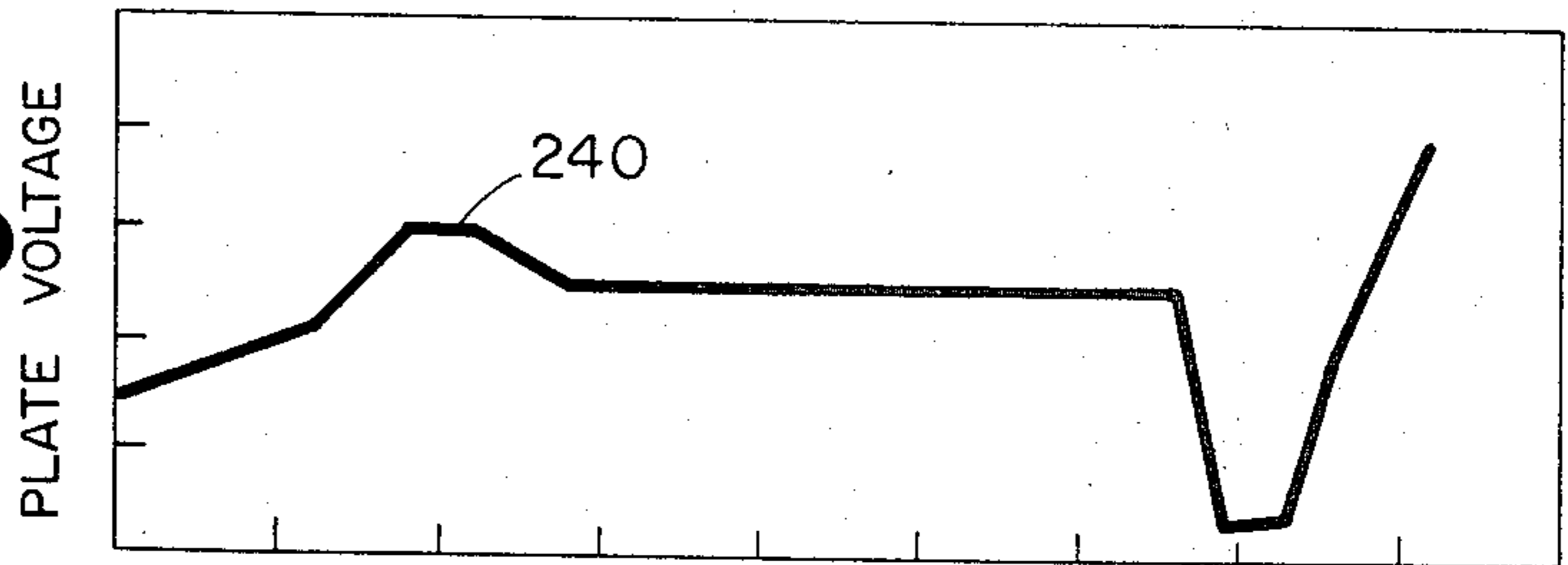
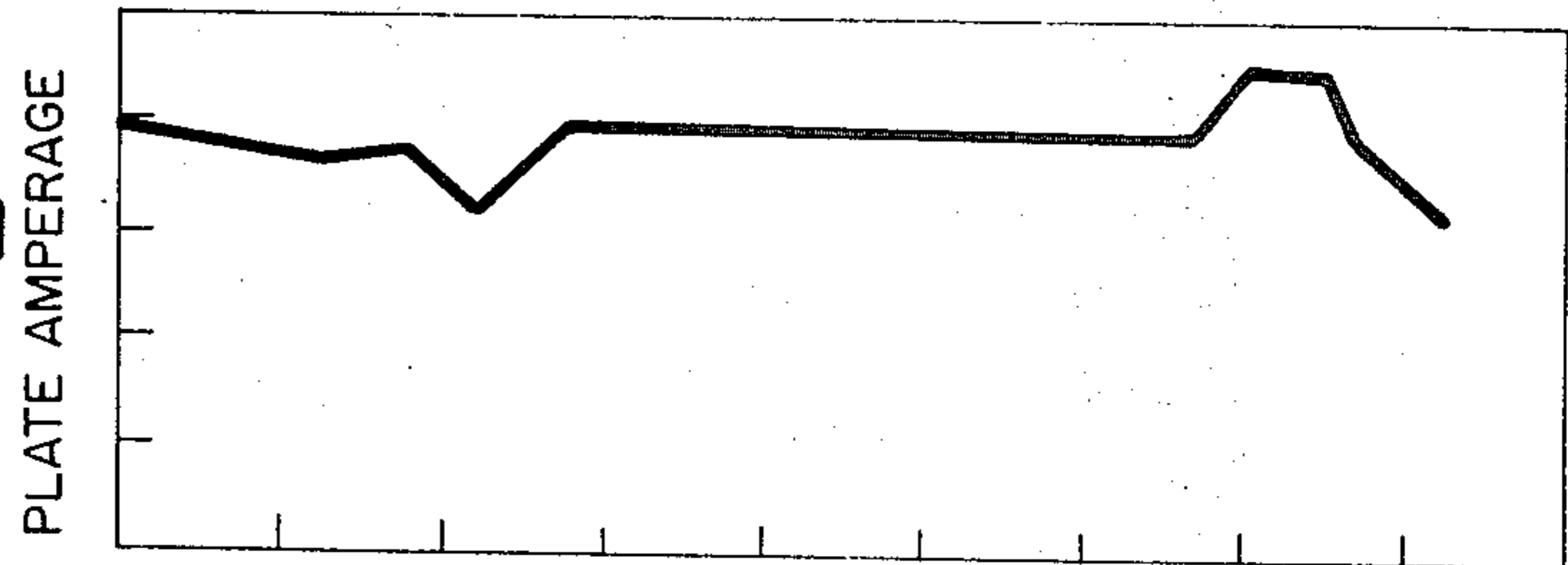

FIG 9a

FIG 9b

FIG 9c

SETTING OF GRID INDUCTOR

1

3,530,334

INDUCTION PLASMA GENERATOR HAVING IMPROVED CHAMBER STRUCTURE AND CONTROL

Merle L. Thorpe and Kent W. Harrington, Suncook, N.H., assignors to Humphreys Corporation, Concord, N.H., a corporation of New Hampshire

Filed Sept. 14, 1967, Ser. No. 667,786

Int. Cl. H01j 7/24; H05b 31/26

U.S. Cl. 315-111

16 Claims

ABSTRACT OF THE DISCLOSURE

An induction plasma generator has a plasma forming chamber defined by sixty-seven axially extending metal tubes surrounded by a 3½ inch diameter ceramic tube that is 7¼ inches long. A six turn induction coil of ¼ inch copper tubing surrounds the ceramic tube. Extending into one end of this chamber is an assembly that defines a main gas injector and an auxiliary gas injector with a tube (2⅛ inches I.D. and 6½ inches long) between the two injectors. The main injector has twelve axial discharge ports, twelve radial discharge ports and twelve swirl ports, while the auxiliary injector has forty-two axial ports, and six swirl ports.

This invention relates to induction plasma generators and more particularly to apparatus for inductively heating a gas with high frequency electrical energy. Such generators create high temperature thermal plasma gas by inductive coupling high frequency electrical energy to ionized gas and are useful for a variety of purposes, including producing chemical reactions, material testing and treatment, and general industrial heating.

An object of this invention is to provide novel and improved induction plasma generators.

Another object of the invention is to provide a novel and improved induction plasma generator configuration which provides stable operation with a variety of gases and of a variety of plasma chamber configurations.

Another object of the invention is to provide novel and improved configurations of induction plasma generators particularly useful in industrial processes which involve either the heating of fluids or the injection of particles into a heated gaseous stream.

Still another object of the invention is to provide a novel and improved plasma chamber configuration for use in induction plasma generators.

Other objects of the invention include the provision of novel and improved control and ignition techniques for use with induction plasma generators.

Plasma generators of the type to which the invention relates include a plasma chamber, an induction coil surrounding the chamber, and an injector for introducing gas into the chamber for conversion to thermal plasma condition under the influence of the electromagnetic field created by the induction coil. In accordance with one feature of the invention, a multiplicity of closely spaced, axially extending tubular elements are used to form the plasma chamber, together with means for passing a coolant material through the tubular elements. Such a plasma chamber defining structure has been found to have greater resistance to damage at high heat flux than ceramic materials such as quartz and thus permits greater energy transfer to the output gas without significant reduction in the efficiency of the generator. It has been found necessary from the standpoints of electrical and gas flow stability that each tubular element be a small fraction of the angular extent of plasma chamber and it is preferred that that angular extent

2

be less than twenty degrees. In a particular embodiment the tubular elements are metal cylinders.

Another feature of the plasma generators is the use of a porous disc element as the axial flow distributor component in the injector structure. Such disc elements provide axial gas flow over their entire surface areas and improve the distribution and volume of gas flow in stable plasma generator operations. In order to provide uniform gas distribution it is desired that the porous element have a pressure drop of at least five inches of water and a pore size of less than twenty-five microns is preferred.

Other features of the invention include discharge nozzle arrangements which enable improved injection of particles for treatment by the stream of hot gas emerging from the generator; and which provide increased protection for elastomeric sealing members employed in the plasma generator.

Still another feature relates to an improved mode of operation of plasma generators. The electrical system is provided with a continuously variable control (either an inductor or a capacitor) in the oscillator grid circuit which is adjusted to vary oscillator parameters and maximize the electric potential applied to the plasma chamber coil at no load (no plasma arc in the plasma chamber); gas in the plasma chamber is then ionized and the electric field couples to the ionized gas to establish the plasma condition; and then the variable control is further adjusted to increase current flow in the oscillator control circuit within the region of maximized electric potential on the plasma coil. Such operation has been found to increase the percentage of power transferred to the plasma gas and hence increased the useful output of the generator. As the region of optimum operation is relatively narrow, the provision of a continuously variable control to obtain this mode of operation is particularly useful.

Other objects, features, and advantages of the invention will be seen as the following description of particular embodiments progresses, in conjunction with the drawings, in which:

FIG. 1 is a sectional view of a first embodiment of an induction plasma generator constructed in accordance with the invention;

FIG. 2 is a sectional view, taken along the line 2-2 of FIG. 1 of the plasma chamber of the generator;

FIG. 3 is a sectional view of a modified form of injector useful in the apparatus shown in FIG. 1;

FIG. 4 is a sectional view of a second embodiment of a plasma generator constructed in accordance with the invention;

FIG. 5 is a sectional view along the line 5-5 of FIG. 4, details of the structure defining the wall of the plasma chamber;

FIG. 6 is a schematic diagram of induction coil energizing circuitry for use with the induction plasma generator arrangements shown in FIGS. 1-5;

FIG. 7 is an end view of the inductor tuning arrangement used in the circuit of FIG. 6;

FIG. 8 is an enlarged side view of a portion of the inductor tuning arrangement shown in FIG. 7;

FIG. 9a, b and c are a series of three curves indicating variation in oscillator parameters of the circuit shown in FIG. 6 as a function of the position of the variable control inductor; and

FIG. 10 is a modified form of nozzle useful for processing particulate matter with the generators shown in FIGS. 1 and 4.

The plasma generator as shown in FIG. 1 includes a base 10 having a central bore 12 in which a main gas injector assembly 14 is mounted. A groove 16 in the bore houses an O-ring 18 which is employed as a seal against the injector assembly and set screws 20 secure the injector assembly 14 in axial position relative to base 10.

The injector assembly includes a cylindrical body 22 (two inches in diameter) having a central material introducing passage 24 and three axially extending gas flow passages 26, 28, and 30. A counterbore 32 at the upper end of cylinder 22 provides a seat for a mixer head 40 which is secured in place by stud 42 (that has a hollow passageway 43 which is aligned with and forms an extension of passageway 24). Mixer head 40 includes a cylindrical block 44 (1.875 inches in diameter) having at its upper end an annular distributor channel 45 (0.062 inch deep and 0.312 inch wide) over which is secured a ring 46 having a series of twelve 0.026-inch axial discharge ports 47 disposed in it on 1.200-inch diameter center. Immediately below channel 45 are two peripheral distributor channels 48 (in communication with passage 26) and 50 (in communication with passage 30). On the wall of the seated mixer body is an annular ring 52 having a set of twelve radially extending ports 54 (each 0.026 inch in diameter) disposed immediately in front of distributor channel 48 and a set of twelve swirl ports 56 (each 0.026 inch in diameter) disposed in front of distributor channel 50.

Mounted on base 10 is a spacer 60 which houses a transition channel—auxiliary gas injector structure. Housing 62, in which induction coil 64 and plasma chamber defining quartz tube 66 are disposed, is in turn mounted on spacer 60. Through bolts 68 pass through base 10 and spacer cylinder 60 into housing 62 and secure that assembly together. End cap 70 on the upper end of housing 62 secured in position by bolts 72.

Spacer cylinder 60 has an inner diameter of $3\frac{1}{4}$ inches and receives in sealing relation a stabilizing structure in the form of transition channel 80 and auxiliary injector structure 89. Transition channel structure 80, of two inches inner diameter and $4\frac{7}{8}$ inches long, includes a water cooled section made up of walls 82 and 84, upper header 85, lower header 86 and cylindrical quartz separator 88 one-half inch in length, the end of which is located substantially in alignment with the lower power lead of coil 64. Surrounding transition channel 80 is an auxiliary gas injector structure 89 that includes an annular axially extending buffer passage 90, $\frac{1}{16}$ inch in width, and a surrounding annular axially extending main passage 92, $\frac{3}{16}$ inch in width. Auxiliary gas is supplied to buffer channel 90 through port 94 and passage 96; while the main flow of auxiliary gas is supplied through port 98 to distributor channel 100 and through radial ports 102 (42 in number, each 0.026 inch in diameter), and through a second main inlet including port 104 to distributor channel 106 and through swirl ports 108 (12 in number, each 0.026 inch in diameter).

It will be noted that the auxiliary gas distributor and transition channel structure, formed as an integral unit, are mechanically positioned with respect to injector structure 14 so that a precise coaxial configuration results. Quartz tube 88 forms an extension of the inner wall of transition structure 80 so that a smooth flow of plasma gas (separate from the auxiliary gas supplied by injector structure 89) is provided along the walls of the quartz extension 88.

A coolant passage inlet 110 extends from the mating surface between cylinder 60 and housing 62, to the channel between walls 82 and 84 and an outlet passage 112 extends radially outwardly from the channel between walls 82 and 84 at the side opposite inlet 110.

Housing 62, of a suitable material of uniform high dielectric integrity, which is unaffected by the coolant employed, a suitable material being polytetrafluoroethylene (Teflon), has attached tubular electrical terminals 120, 122, each of which has a water cooled passageway 124. The upper terminal 120 is connected to terminal block 126, which in turn is connected to one end of coil 64 ($\frac{3}{32}$ -inch round copper wire wound to provide five turns over a length of about 4 inches, about $3\frac{1}{4}$ inch I.D.). The other end of coil 64 is connected to block 128 to

which terminal 122 is threadedly connected. The coolant passage 124 of terminal 122 is connected to passage 130 in housing 62 which passage is in turn aligned with passage 110 in section 60. A second passage 132, connected to annular chamber 134 in which coil 64 is disposed, permits coolant flow upwardly past coil 64 and around the upper end of quartz tube 66 for return through exit passage 136 to the passage 124 in upper terminal 120.

The nozzle 140 secured to end cap 70 provides a restricted orifice through which both the plasma gas and the auxiliary gas flows. In addition, the nozzle structure extends down into the plasma chamber defined by quartz tube 66 sufficiently to interpose a shield opaque to radiation from the arc region between that arc region (indicated at 142) and the upper quartz tube support O-ring 144. The transition channel structure 80 provides a similar radiation opaque protective shield for lower O-ring 146. A number of other O-ring seals 148 are provided between the mating components of the generator, end cap 70 and housing 66; housing 66 and cylinder 60; and auxiliary injector 89 and cylinder 60 and base 10.

In a typical operation of this plasma generator a plasma is initiated by introducing argon gas at 30 s.c.f.h. through axial inlet ports 46 (passage 28) and 80 s.c.f.h. through inlet ports 56 (passage 30). The plasma may be initiated by suitable means such as temporary insertion of a graphite rod into the plasma chamber where it is heated by the electromagnetic field established by coil 64. After the plasma is created, the plasma sustaining argon flow is adjusted to the following values:

Passage:	S.c.f.h.
26	40
28	0
30	80

The resulting arc 142 is of configuration generally as indicated in FIG. 1. A gas for chemical reaction or for analysis purposes may be supplied through ports 94, 98, and 104. Port 94 is primarily for buffering purposes while the main gas flow is through port 98 (with added gas through port 104 is desirable). With this apparatus hydrogen as the auxiliary gas has been heated to a temperature of 2800° F. at a flow rate of 3600 s.c.f.h. distributed among the auxiliary ports in the following quantities:

Port	S.c.f.h.
94	200-1000
98	2600-3600
104	0

in a continuous operation over one hour without creating instability in the arc 142. At lower flow rates hydrogen introduced through the auxiliary injector 89 has been heated up to 5000° F.

A modification of the main gas injector, useful particularly with argon as the arc forming gas as it produced longer and hotter gas stream issuing from the torch with the same power and allows a substantial increase in power capability of the generator without failure of quartz tube 66, is shown in FIG. 3. A porous bronze metal disc 200, $\frac{1}{8}$ inch in thickness and $1\frac{5}{8}$ inch diameter when it is positioned coaxially with respect to the $1\frac{7}{8}$ inch diameter mixer structure as substitution for the axial orifices 47 (in plate 46). The center section defined by stud 42 was $\frac{1}{2}$ inch in diameter. Porosities of 1.5 to 25 microns which produced pressure drops of 30-70 to 7-14 inches of water respectively were operated satisfactorily. Satisfactory operation was also obtained with a main injector that employed a porous bronze disc without stud 42 so that the main gas flow extended over the entire width of the disc. Also, a porous ring of this type may be utilized at the annular outlet of the auxiliary injector 89.

A second embodiment is shown in FIGS. 4 and 5. That plasma generator has a base 10' in which is supported a plasma gas (main) injector structure with a mixer head diagrammatically indicated at 40' and an auxiliary gas injector transition channel structure 60'. Disposed in structure 60' is a transition channel insert 150, 2 1/8 inches in inner diameter, and 6 1/2 inches in length. This transition channel 150 includes a base 152 which is threadedly secured to the section 60'; an inner metal wall 154 to which is secured a header 156 on which is received quartz tubular extension 158; and a surrounding tubular wall member 160 which depends from header 156 and forms with wall 154 an annular coolant channel 162.

A third tubular member 164, also secured to header 156, has a series of 42 axial ports 166 (0.026 inch in diameter) and a series of 6 swirl ports 167 (0.026 inch in diameter) in communication with annular chamber 168 formed between members 160 and 164. This insert structure 150 is secured in structure 60' which includes coolant inlet 170, coolant outlet 172, and auxiliary gas inlet 174. O rings 176 provide seals to isolate the coolant from the auxiliary gas.

Mounted on spacer 60' is a plasma chamber defining structure which includes a base 180 (functioning as a header) to which are secured in a ring a series of 1/8 inch O.D., 0.085 I.D. copper tubes 182 spaced 0.022 inch apart. The lower ends of the tubes are soldered to base 180 for communication with distributor channel 184 which in turn is connected to inlet port 186 and outlet port 188. The upper ends of tubes 182 are similarly connected to header 190. The distance headers 180 and 190 is 5 3/4 inches and the inner diameter of each header is three inches.

Surrounding the set of tubes 182 is a ceramic (Rotasil) tube 192, 3 1/2 inches I.D. and 7 1/4 inches long. A six turn induction coil 64' of 1/4 inch O.D. copper tubing surrounds the tube 192 and is connected to the power supply.

The use of this metal wall structure to define the plasma chamber has been found to have particular advantage in operating the generator without auxiliary gas flow. For example, generators in which the plasma chamber is defined by the ring of metal tubes have been operated with percentages of hydrogen in the main gas flow in excess of those percentages which would cause cracking of the quartz tube in a generator of the type shown in FIGS. 1 and 2. Further, higher power densities were obtainable with the ring of tubular elements. In a generator having a one-inch diameter plasma chamber formed of tubes as above described, a power density of 60 kilowatts was obtainable while a power density of 25 kilowatts was the maximum obtainable using a one-inch diameter quartz tube.

Ignition of this plasma generator configuration may be obtained by contacting a graphite plate on stud 42 of mixer 40 with an energized electrode introduced axially through the discharge end of the plasma chamber. A DC arc is drawn, ionizing gas in the chamber to which the electric field produced by coil 64 couples.

Operation of the plasma generator shown in FIGS. 4 and 5 with the following values has been obtained:

Argon center core—115 s.c.f.h.
 Hydrogen sheath—2730 s.c.f.h.
 Coil turns—6.
 Coil I.D.—4 inches.
 Oscillator tank capacitor—900 microfarads.
 Blocking capacitor—125 microfarads.
 Frequency—2.5 mc.

In a modification of the plasma generator structure shown in FIG. 4, the plasma chamber structure shown in FIG. 1 may be substituted while locating the coil 64 at the end of the quartz extension 158 in the same relation as shown in FIG. 4. Operation with the following values

(which may be compared with those indicated above) was obtained:

Argon center core—120 s.c.f.h.
 Hydrogen sheath—3610 s.c.f.h.
 Coil turns—5.
 Coil I.D.—3.3 inches.
 Oscillator tank capacitor—900 microfarads.
 Blocking capacitor—200 microfarads.
 Frequency—3.1 mc.

The heat energy in the gas leaving the torch was measured to be in excess of 40% of the DC input energy to the generator.

A schematic diagram of an electrical system used with these plasma generators is shown in FIG. 6. That system includes an oscillator tube 210 to which D.C. power is applied over lines 212, 214. The plate (output electrode) 216 of tube 210 is coupled by blocking capacitor 218 to the main tank circuit that includes capacitors 220, 222, an adjustable inductor coil 224 and generator coil 64. Connected to the grid (control electrode) 226 of tube 210 is capacitor 228 and continuously variable inductor 230. Diagrammatic end and side views of continuously variable grid inductor 230 are shown in FIGS. 7 and 8. The inductor coil 230 has thirty-six turns, one of which is contacted by a tap in the form of two juxtaposed discs 232, 234 which are mounted on an arm 236 which arm, in turn, is mounted for rotation on shaft 238 at the center of coil 230. This tap structure, as shaft is rotated, transverses the helical coil 230 and thus permits variation of the tap position over a large and continuous range.

Variation of system plate voltage, plate amperage, and grid amperage as a function of the position of the tap on coil 230 under no load operation is indicated in FIGS. 9A-C. In operation, region 240 is first located (the region of maximum plate voltage [FIG. 9B] and minimum plate amperage [FIG. 9A]). The plasma arc 142 is then ignited to establish a load. The setting of the grid inductor is then varied to maximize the grid amperage within region 240 and the power ratings of the system.

A modified nozzle structure 140' which has particular utility for introducing particulate material into the flow of heated gas from the plasma chamber is indicated in FIG. 10. The nozzle has a discharge passage section 250, 1 1/2 inches in diameter, and a tapered transition section that includes a first segment 252 disposed at a 45° angle to the axis of the generator and a second segment 254 disposed at a 60° angle to the axes of the generator. Extending from the outer wall of the nozzle to the discharge passage section 250 are two opposed passages 256, 258, each of which is 0.082 inch in diameter and which is drilled at an angle of 120° to the direction of gas flow through the discharge passage 250. Flanges 260 and 262 provide clamping and sealing surfaces for securing the nozzle 140' to the plasma generator structure.

In operation, particulate matter is introduced through passages 256, 258 into the stream of hot gas issuing from the plasma chamber. The particulate material is introduced in a direction countercurrent to the gas flow and at a point within the cylindrical discharge passage section 250 so that it is acted on by the hot gas flow for a substantial period of time while none of the heated particulate matter impinges on any surface of the nozzle structure disposed at an angle to the direction of gas flow through the nozzle structure. In this manner all the heated particulate matter is carried out of the nozzle structure by the gas flow in the heat treatment process and does not accumulate on nozzle surfaces.

While particular embodiments of the invention have been shown and described, various modifications thereof will be obvious to those skilled in the art. The specific dimensions and configurations of the described embodiments are for purposes of illustration and not in-

tended as limitations other than as recited in the claims. It is therefore not intended that the invention be limited to the disclosed embodiments or to details thereof and departures may be made therefrom within the spirit and scope of the invention as defined in the claims.

What is claimed is:

1. An induction plasma generator comprising means defining a plasma chamber including a multiplicity of closely spaced, axially extending tubular elements, means for passing coolant fluid through said tubular elements,

a high frequency electrical coil surrounding said chamber for creating an electric field within said chamber,

a main gas injector spaced from one end of said chamber for introducing a first gas for flow into said plasma chamber and conversion to plasma arc condition under the influence of said electric field, and a stabilizing structure of smaller cross-sectional dimension than said plasma chamber for introducing said first gas from said main injector to said plasma chamber in the vicinity of said electrical coil in a main stream coaxial with and spaced from the wall of said plasma chamber.

2. The plasma generator as claimed in claim 1 wherein each said tubular element is a metal cylinder and the spacing between each pair of adjacent cylinders is less than 0.1 inch.

3. The induction plasma generator as claimed in claim 1 wherein said gas injector includes a gas distributor body having a recess therein, and a porous disc element disposed over said recess between said recess and said plasma chamber for passing gas from said recess in the axial direction for flow through said plasma chamber, said disc element having porosity producing a gas flow pressure drop across said disc element of at least five inches of water.

4. The plasma generator as claimed in claim 3 wherein said disc element is a metal element having a pore size of less than twenty-five microns.

5. The induction plasma generator as claimed in claim 1 and further including a high frequency oscillator for energizing said electrical coil, said oscillator including a control device having an output circuit and a control electrode, a tank circuit connected across the output circuit of said control device, said tank circuit including said electrical coil, and a continuously variable inductor connected to said control electrode.

6. An induction plasma generator comprising means defining a plasma chamber, an electrical coil surrounding said chamber, a high frequency oscillator for energizing said electrical coil, said oscillator including a control device having an output circuit and a control electrode, a tank circuit connected across the output circuit of said control device, said tank circuit including said electrical coil and a continuously variable inductor connected to said control electrode, said continuously variable inductor including a helical coil, a rotatable shaft coaxially disposed inside said helical coil, and a tap structure mounted on said rotatable shaft, said tap structure having an end portion in wiping engagement with a portion of one turn of said coil and adapted to be moved along said coil in a helical path to traverse the length of said coil in response to rotation of said shaft and a main gas injector spaced from one end of said chamber for introducing a first gas for flow into said plasma chamber and conversion into plasma arc condition under the influence of said electric field.

7. An induction plasma generator comprising means defining a plasma chamber, a high frequency electrical coil surrounding said chamber for creating an electric field within said chamber, a main gas injector spaced from one end of said chamber for introducing a first gas for flow into said plasma chamber and conversion to plasma arc condition under the influence of said electric field, and a nozzle structure at the output end of

said plasma chamber remote from said main injector, said nozzle structure defining an axially extending discharge passage section of substantially smaller cross-sectional area than the cross-sectional area of said plasma chamber and a tapered transition section between said plasma chamber and said discharge passage section, said nozzle structure defining an axially extending discharge passage having an outlet in said discharge passage section for injecting material into the gas flow in said tapered transition section at an angle greater than 90° to the direction of gas flow through said discharge passage section so that the injected material is carried through said discharge passage section without impingement on a surface of said nozzle structure.

8. An induction plasma generator comprising means defining a plasma chamber,

a high frequency electrical coil surrounding said chamber for creating an electric field within said chamber,

a main gas injector spaced from one end of said chamber for introducing a first gas for flow into said plasma chamber, characterized in that said plasma chamber defining means includes a multiplicity of closely spaced, axially extending tubular elements, and further including means for passing coolant fluid through said tubular elements.

9. The plasma generator as claimed in claim 8 wherein each said tubular element is a metal cylinder and the spacing between each pair of adjacent cylinders is less than 0.1 inch.

10. An induction plasma generator comprising means defining a plasma chamber,

a high frequency electrical coil surrounding said chamber for creating an electric field within said chamber,

a main gas injector spaced from one end of said chamber for introducing a first gas for flow into said plasma chamber, characterized in that said main gas injector includes a gas distributor body having a recess therein, and a porous disc element disposed over said recess between said recess and said plasma chamber for passing gas from said recess in the axial direction for flow through said plasma chamber, said disc element having porosity producing a gas flow pressure drop across said disc element of at least five inches of water.

11. The plasma generator as claimed in claim 10 wherein said disc element is a metal element having a pore size of less than twenty-five microns.

12. An induction plasma generator comprising means defining a plasma chamber,

a high frequency electrical coil surrounding said chamber for creating an electric field within said chamber,

a main gas injector spaced from one end of said chamber for introducing a first gas for flow into said plasma chamber and conversion to plasma arc condition under the influence of said electric field, and a high frequency oscillator for energizing said electrical coil, said oscillator including a control device having an output circuit and a control electrode, a tank circuit connected across the output circuit of said control device, said tank circuit including said electrical coil, and a circuit including a continuously variable inductor element and a capacitor element connected to said control electrode, said continuously variable inductor element includes a helical coil, a rotatable shaft coaxially disposed inside said helical coil, and a tap structure mounted on said rotatable shaft, said tap structure having an end portion in wiping engagement with a portion of one turn of said coil and adapted to be moved along said coil in a helical path to traverse the length of said coil in response to rotation of said shaft.

13. The induction plasma generator as claimed in claim 12 wherein said main gas injector includes a gas distributor body having a recess therein, and a porous disc element disposed over said recess between said recess and said plasma chamber for passing gas from said recess in the axial direction for flow through said plasma chamber, said disc element having a pore size of less than twenty-five microns and producing a gas flow pressure drop across said disc element of at least five inches of water.

14. The induction plasma generator as claimed in claim 13 wherein said means defining a plasma chamber includes a multiplicity of axially extending metal cylinders spaced less than 0.1 inch apart, and further including means for passing coolant fluid through said cylinders.

15. The plasma generator as claimed in claim 14 and further including a nozzle structure at the output end of said plasma chamber remote from said main injector, said nozzle structure defining an axially extending discharge passage section of substantially smaller cross-sectional area than the cross-sectional area of said plasma chamber and a tapered transition section between said plasma chamber and said discharge passage section, said nozzle structure further including a material injection passage having an outlet in said discharge passage section for injecting material into the gas flow through said nozzle at an angle greater than 90° to the direction of gas flow through said discharge passage section.

16. The method of operating an induction plasma generator having a plasma chamber, a coil surrounding said plasma chamber, and an oscillator for energizing said coil to establish an electric field in said plasma chamber, said oscillator including a tank circuit comprising an inductance and a capacitance, a control device having an output circuit connected to said tank circuit and a control electrode, and a circuit including an inductor element and a capacitor element connected to said control

electrode, at least one of said elements being continuously variable,

comprising the steps of adjusting an element in said control electrode circuit to maximize the voltage in said output circuit,

ionizing gas in said plasma chamber to provide a conductive medium to which the electric field established by said coil will couple, and further adjusting said continuously variable element to maximize the current flow in said control electrode circuit within the region of maximized voltage in said output circuit.

References Cited

UNITED STATES PATENTS

3,077,108	2/1963	Gage et al.	313—231 X
3,246,115	4/1966	Johnson.	
3,264,508	8/1966	Lai et al.	315—111 X
3,301,995	1/1967	Eschenbach et al.	
3,324,334	6/1967	Reed	313—231
3,347,698	10/1967	Ingham.	
3,405,314	10/1968	Van Ornum et al. ...	313—231 X

FOREIGN PATENTS

1,049,536	11/1966	Great Britain.
1,100,211	1/1968	Great Britain.

OTHER REFERENCES

Cooper, "Recent Developments in Plasma Welding," Welding Journal, April 1965, pp. 268-275.

JAMES W. LAWRENCE, Primary Examiner

D. O'REILLY, Assistant Examiner

U.S. Cl. X.R.

313—231

PO-1050
(5/69)

UNITED STATES PATENT OFFICE
CERTIFICATE OF CORRECTION

Patent No. 3,530,334 Dated September 22, 1970

Inventor(s) M. L. Thorpe et al.

It is certified that error appears in the above-identified patent and that said Letters Patent are hereby corrected as shown below:

Column 8, lines 7-8 "defining an axially extending distion" should be --further including a material injection--;
line 42, delete "said recess and".

SIGNED AND
SEALED
DEC 8 - 1970

(SEAL)

Attest:

Edward M. Fletcher, Jr.

Attesting Officer

WILLIAM E. SCHUYLER, JR.
Commissioner of Patents