

Sept. 8, 1970

L. W. BLOOM ET AL

3,527,011

INSULATED PANEL FRAME

Filed Dec. 29, 1967

4 Sheets-Sheet 1

FIG. 1

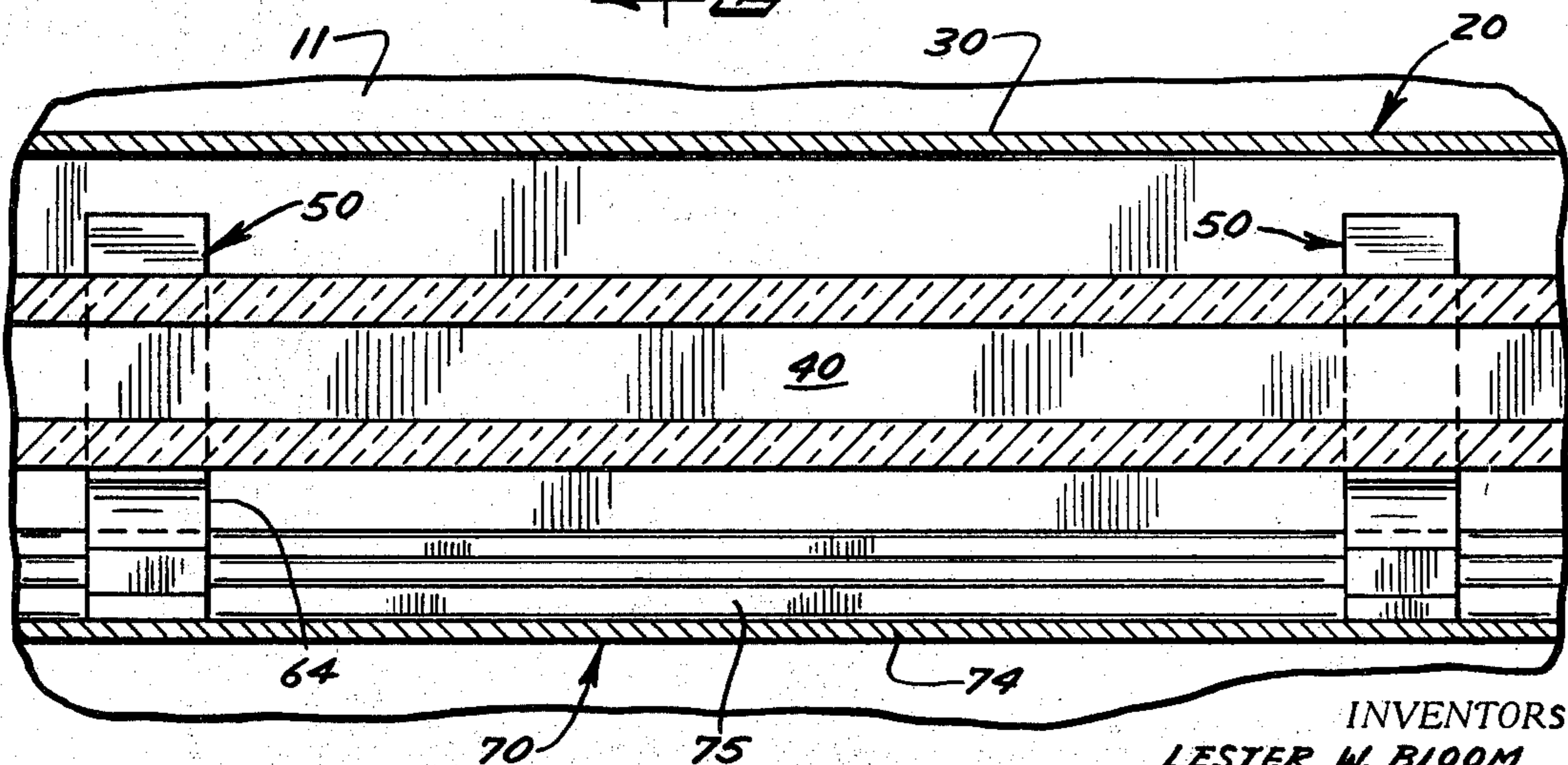
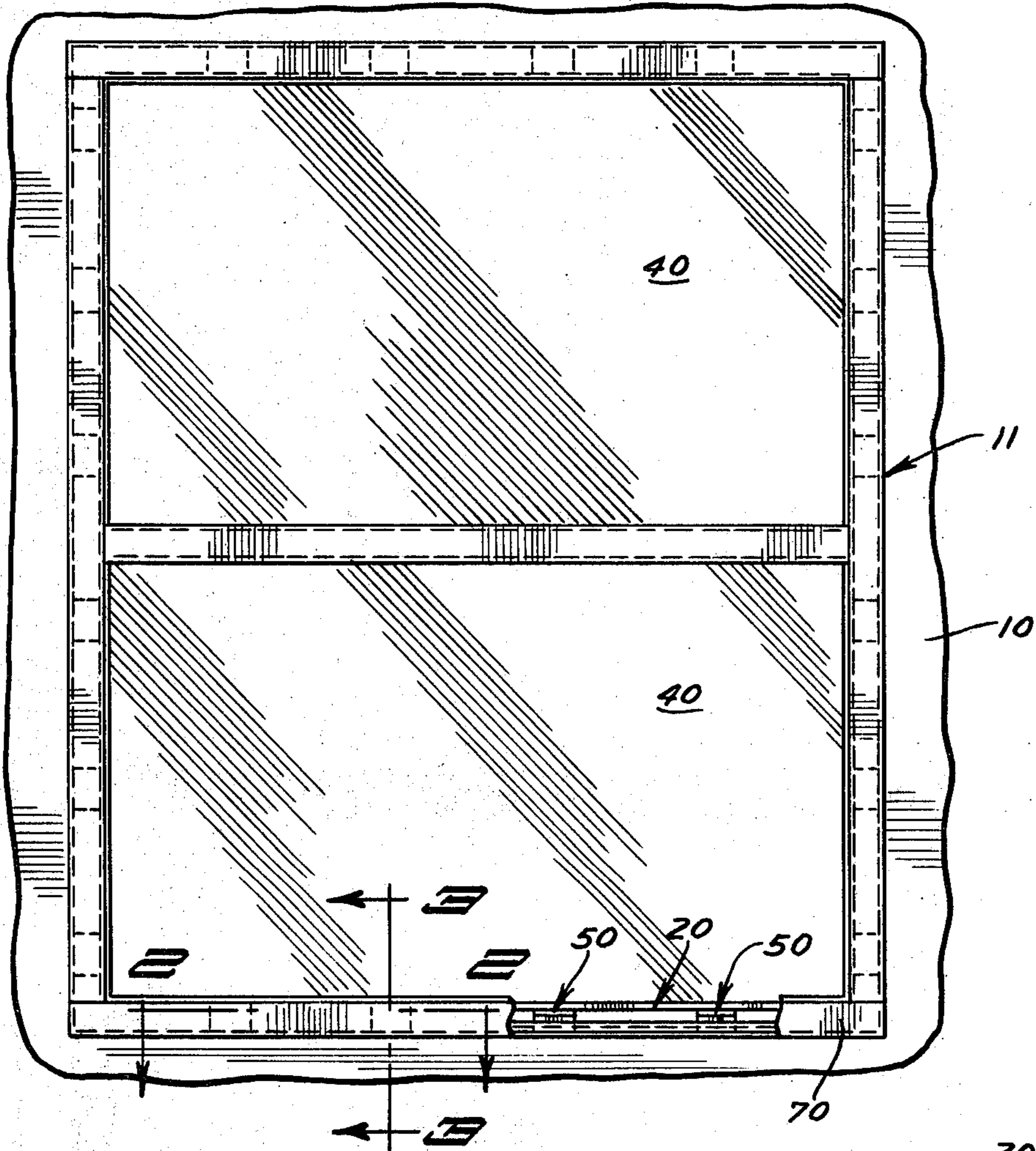

FIG. 2

INVENTORS
LESTER W. BLOOM
THOMAS P. OLSON

BY

Carlson, Carlson, Stearns & Weeks

ATTORNEYS

Sept. 8, 1970

L. W. BLOOM ET AL
INSULATED PANEL FRAME

3,527,011

Filed Dec. 29, 1967

4 Sheets-Sheet 2

FIG. 3

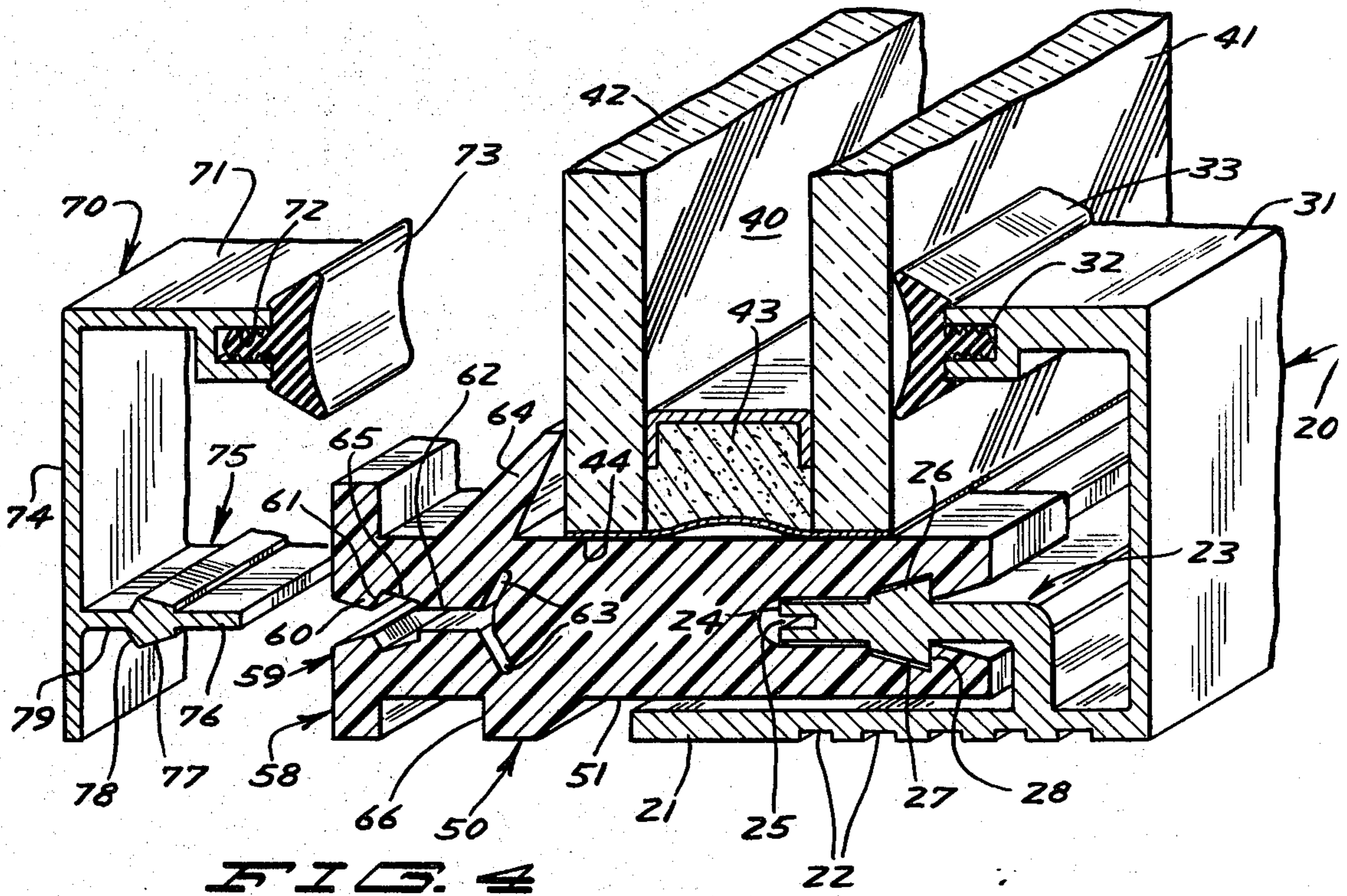
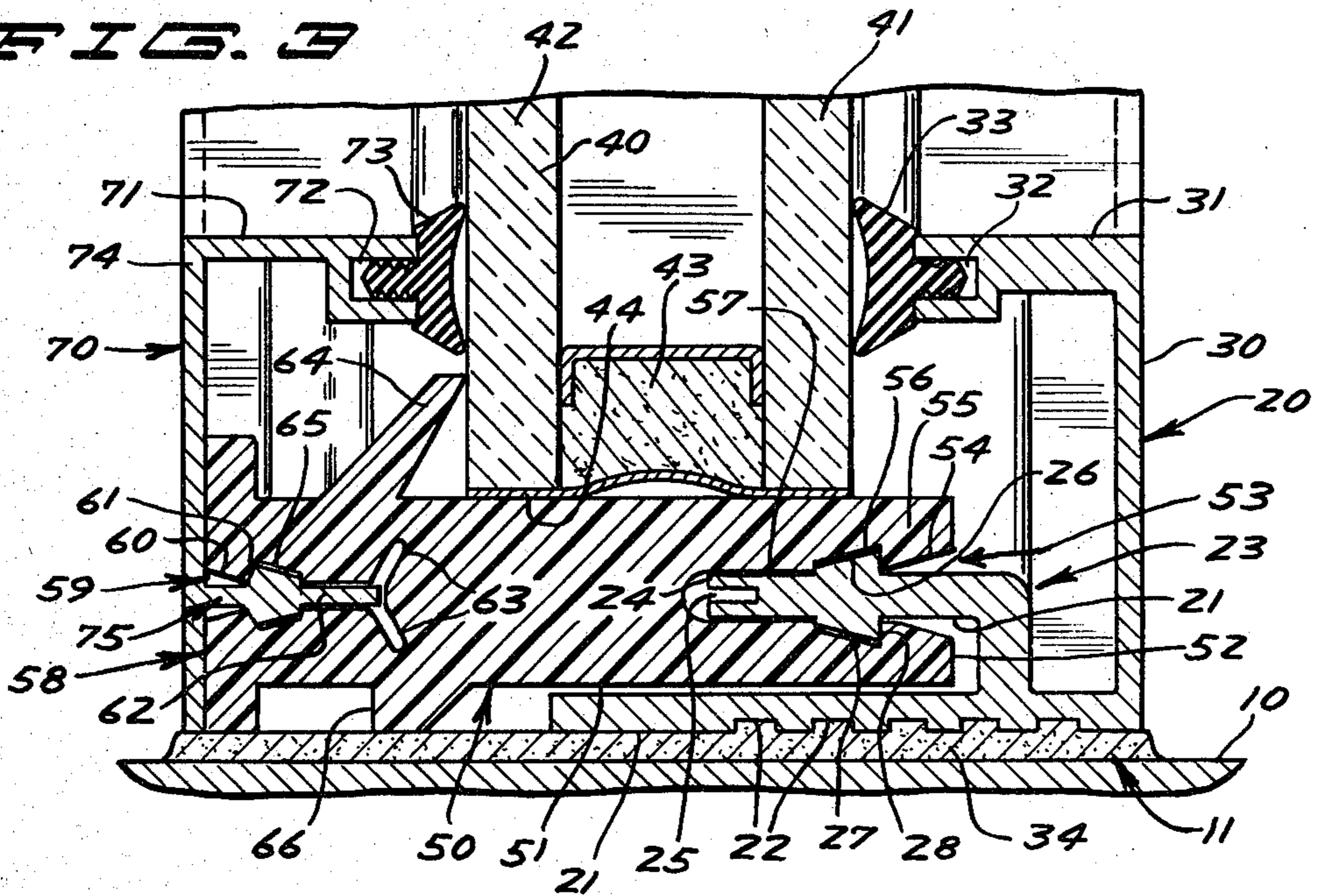

FIG. 4

INVENTORS
LESTER W. BLOOM
THOMAS P. OLSON

BY

Carleyn, Carlson, Starns & Wilco

ATTORNEYS

Sept. 8, 1970

L. W. BLOOM ET AL

3,527,011

INSULATED PANEL FRAME

Filed Dec. 29, 1967

4 Sheets-Sheet 3

FIG. 5

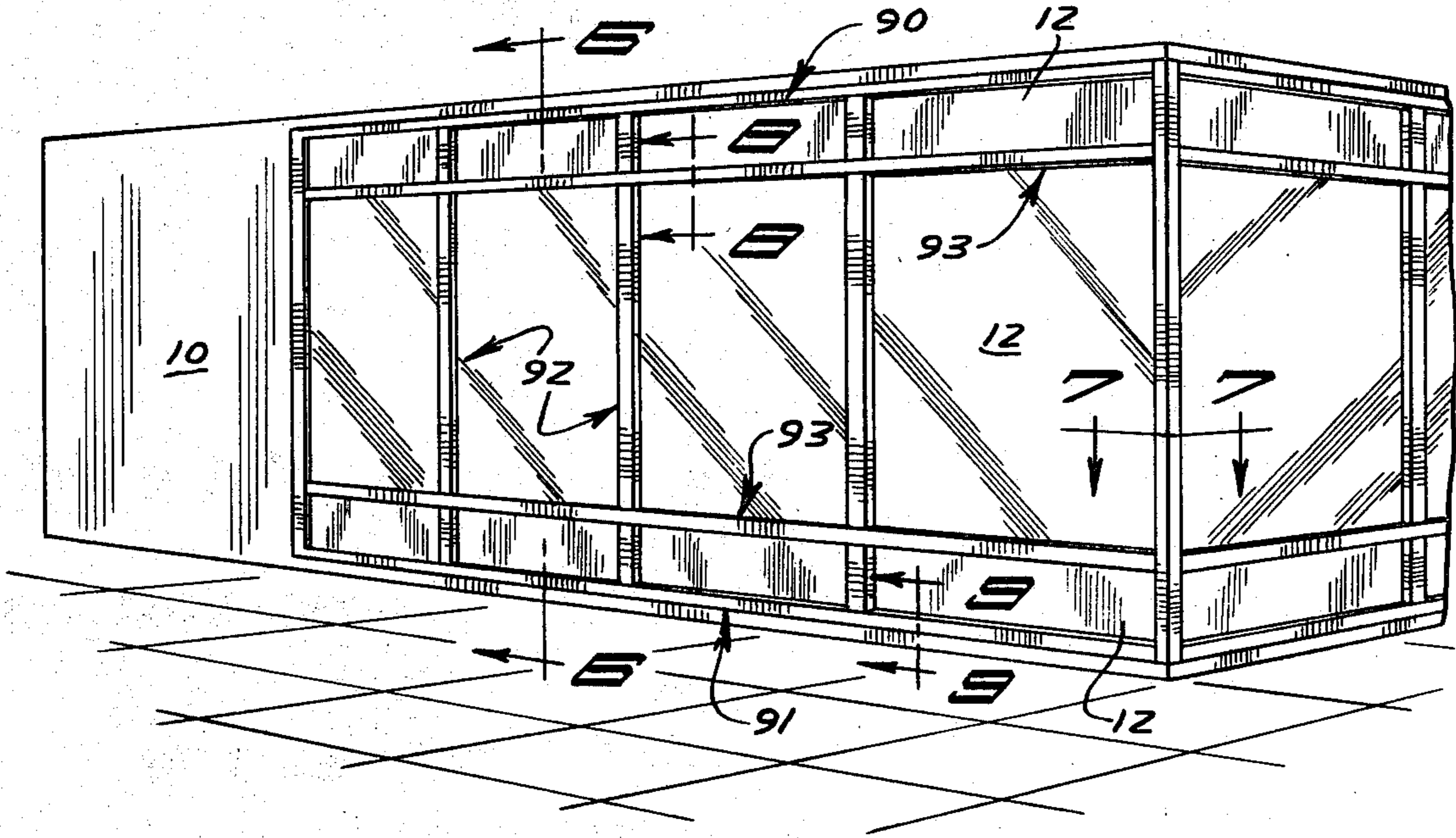
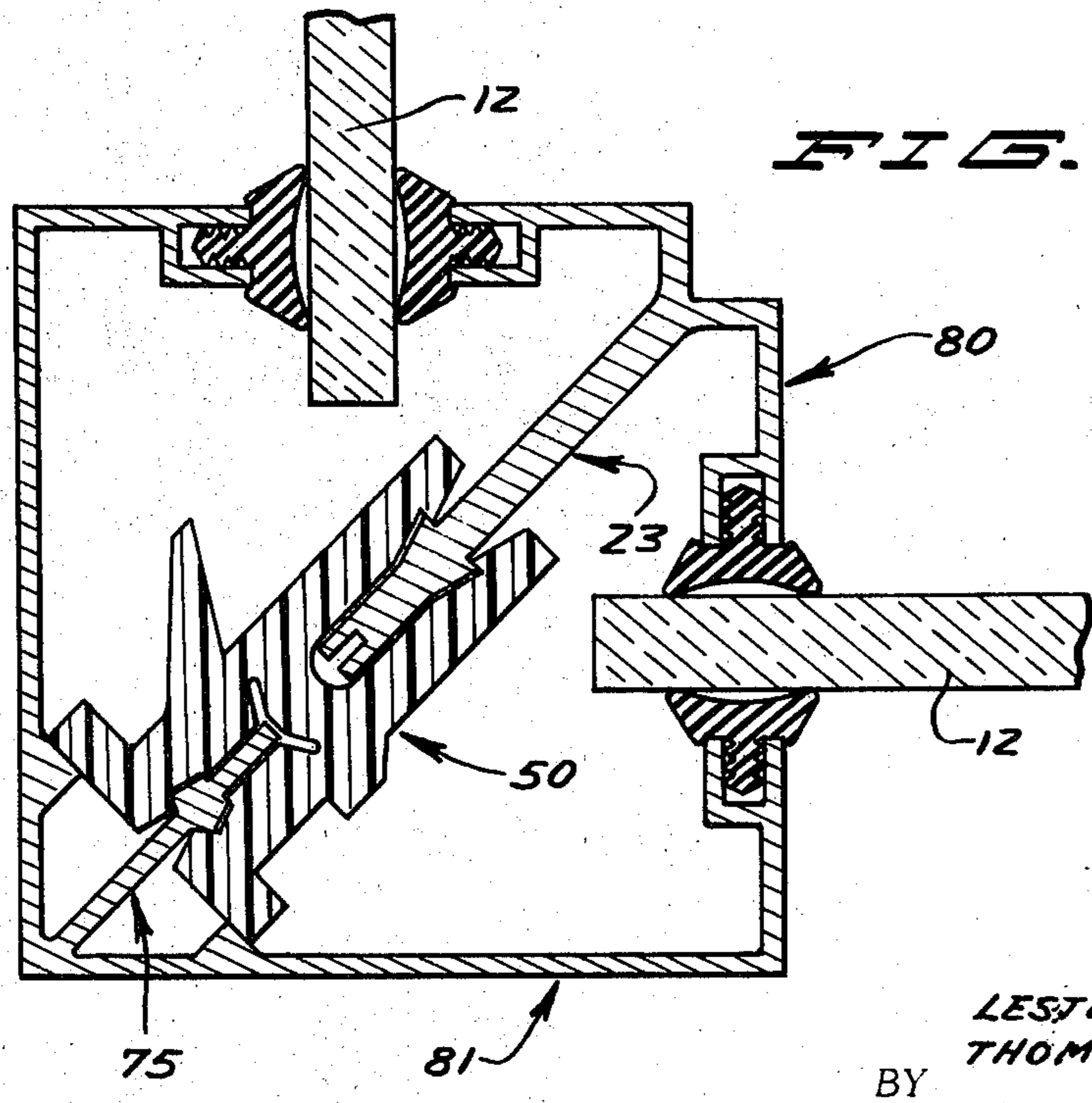

FIG. 7



INVENTORS
LESTER W. BLOOM
THOMAS P. OLSON

BY

Carlson, Carlson, Stumm & Wick
ATTORNEYS

Sept. 8, 1970

L. W. BLOOM ET AL

3,527,011

INSULATED PANEL FRAME

Filed Dec. 29, 1967

4 Sheets-Sheet 4

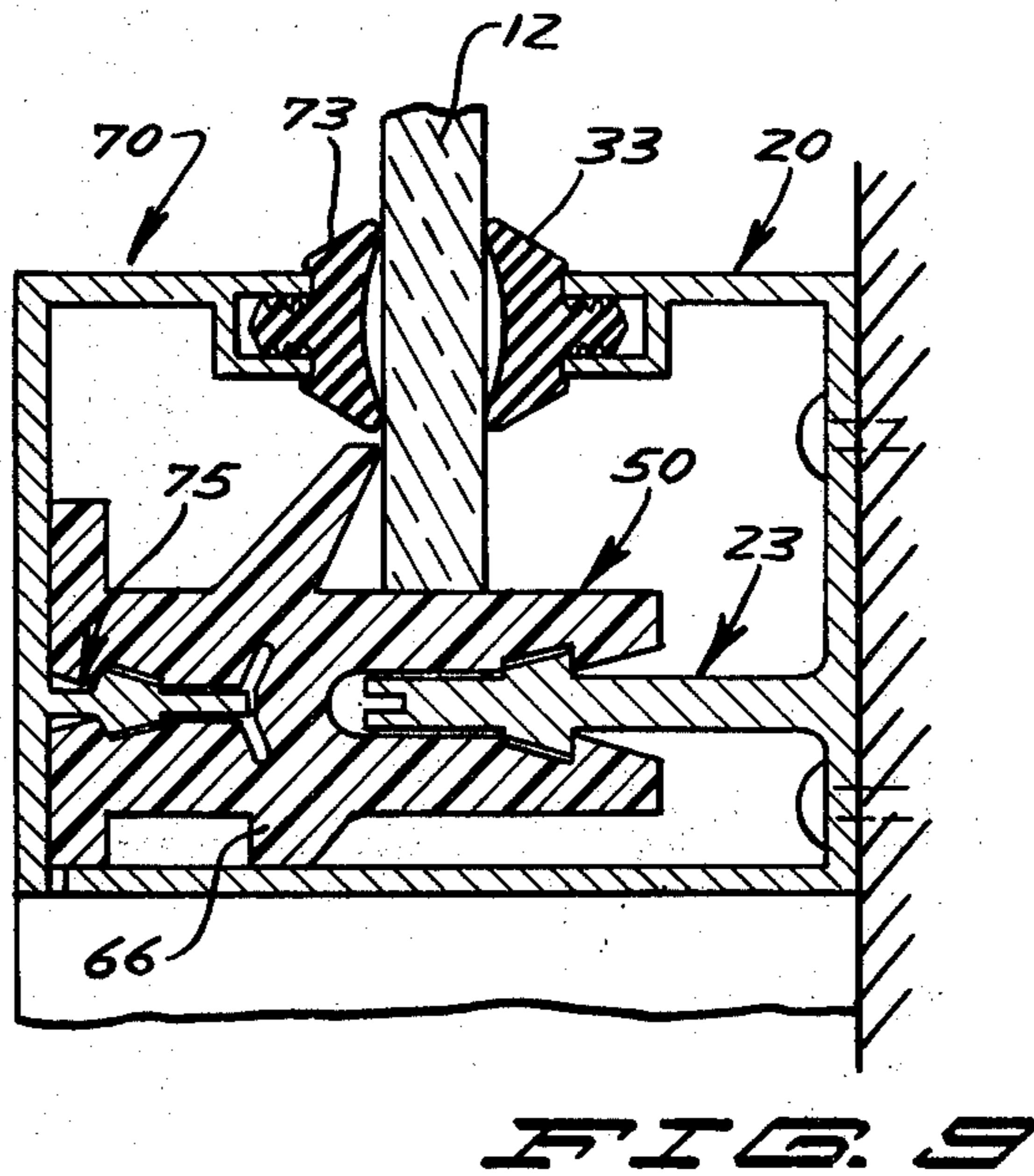
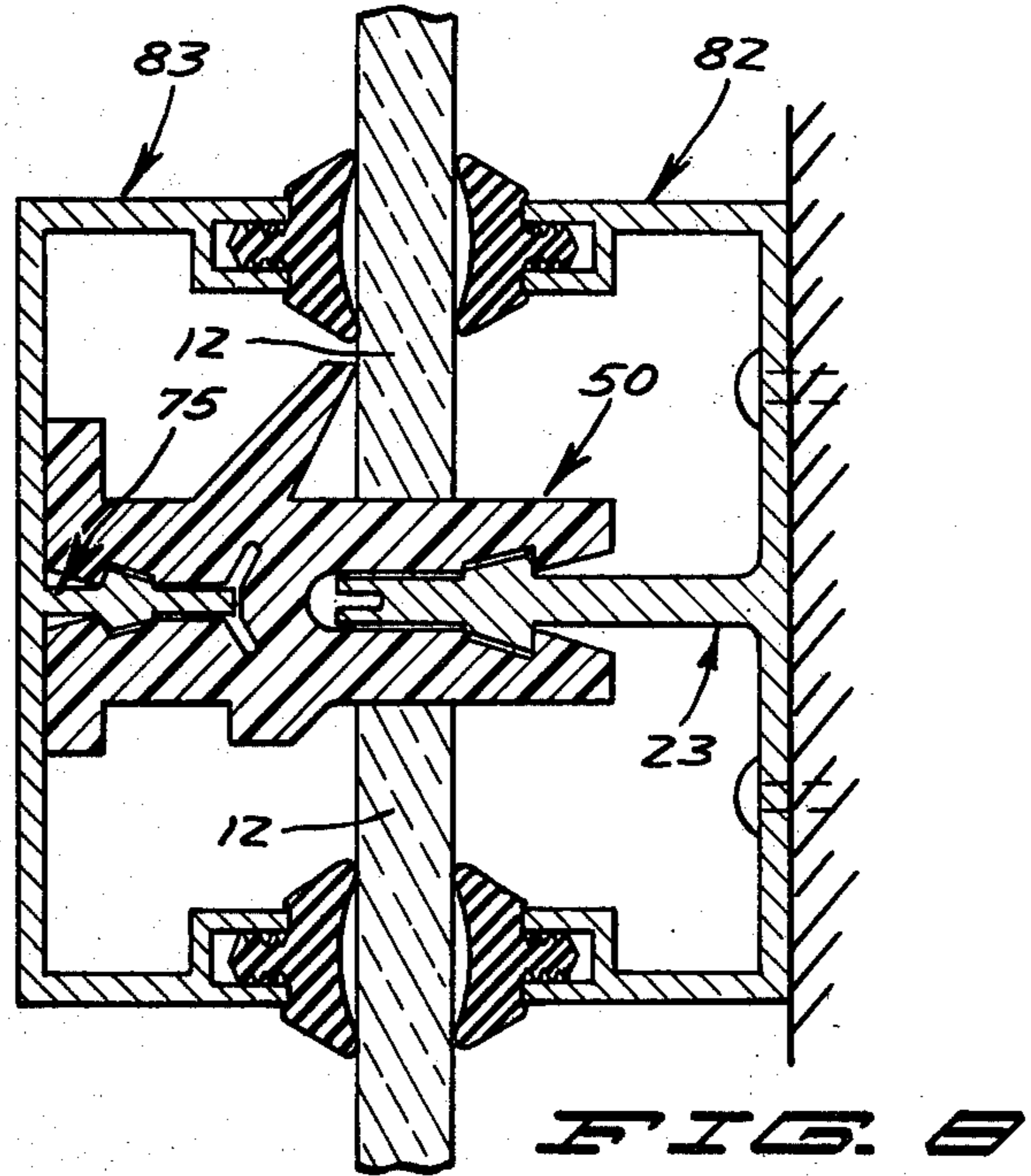
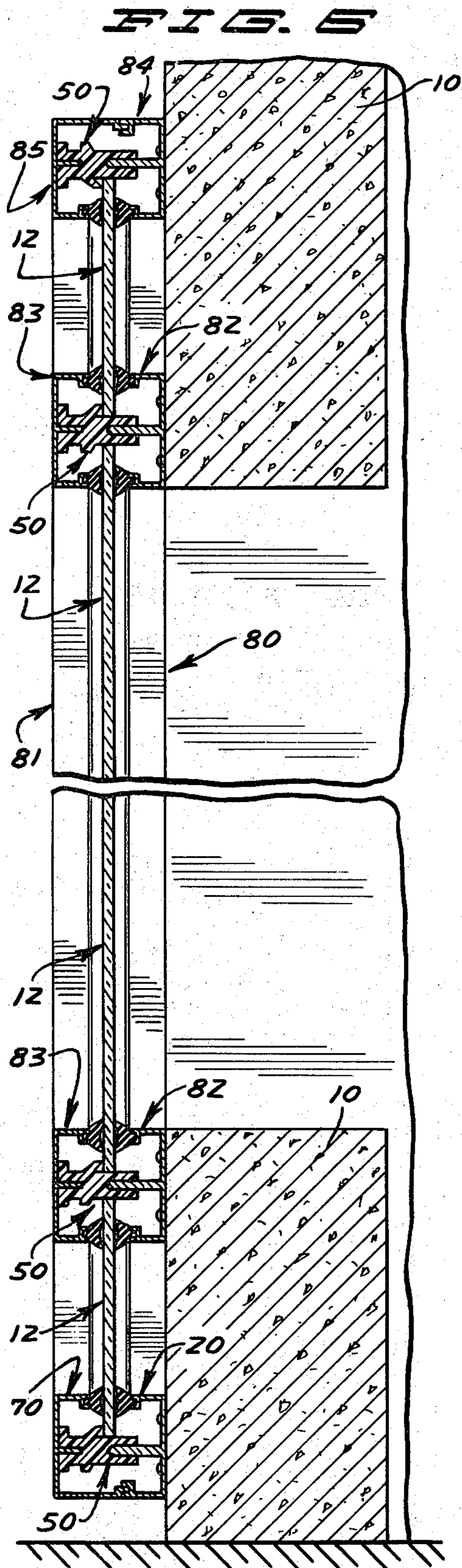

INVENTORS
LESTER W. BLOOM
THOMAS P. OLSON
BY
Carlson, Carlson, Starn & Wicks
ATTORNEYS

1

3,527,011

INSULATED PANEL FRAME

Lester W. Bloom, Richfield, and Thomas P. Olson,
Bloomington, Minn., assignors to Cronstroms Manu-
facturing, Inc., Minneapolis, Minn., a corporation of
Minnesota

Filed Dec. 29, 1967, Ser. No. 694,711

Int. Cl. E06b 1/32

U.S. Cl. 52—398

8 Claims

ABSTRACT OF THE DISCLOSURE

Insulated panel supporting framing members in which a gutter portion is constructed to be rigidly attached to an opening or aperture in a structure and to sealingly engage a panel, a face member is adapted to be disposed outside of the gutter member and is also adapted to sealingly engage a panel and one or more thermally insulated connecting blocks are substantially permanently engaged with a portion of the gutter members and removably engaged with a portion of the face members to support the panel and the face members in a removable predetermined relationship whereby the panel members are disposed and sealingly engaged between the gutter and face members while retaining or maintaining thermal insulation between the gutter and face members and simultaneously supporting and retaining the panel members in operative disposition on a structure.

This invention relates generally to apparatus for supporting and sealingly engaging panel members to be disposed in or over apertures in a structure and is more particularly directed to novel and improved apparatus for removably supporting decorative architectural members and supportively engaging panel members over apertures in a structure while simultaneously providing thermal insulation characteristics between the interior and exterior portions of the structure so as to prevent the transfer of heat to or from the interior while maintaining structural integrity.

In the prior art with which our invention is concerned, the problem of utilizing materials possessing a high thermal conductivity for supporting utilitarian or decorative panels in or on the surface of a structure, such as windows and opaque and translucent materials, has been widespread and prevalent. Common materials utilized in such applications have included, steel and aluminum, both of which possess the required structural strength but lack the universally desired characteristics of low thermal conductivity so that in, for example, climates wherein temperatures vary within wide extremes, the problems created through the use of such materials have substantially outweighed the structural and other characteristics that are gained, for example, over the use of wood, or the like. Many solutions have been proposed to enable the use of structurally satisfactory materials of high heat conductivity but these have failed in commercial application, due to cost, poor mechanical characteristics, difficulty in installation or lack of accessibility from the standpoint of servicing a completed structure.

The present invention is concerned with a panel support frame that is economically and easily constructed, easily erected, provides the desirable insulation to enable the use of structural members of high strength and high thermal conductivity, provides adequate support for panels to be engaged and sealingly supported thereby and which may be rapidly and easily assembled or disassembled for replacement of panels and the like when necessary.

It is therefore an object of our invention to provide

2

a novel and improved panel supporting apparatus for enclosing apertures in a building structure.

A further object of our invention is to provide an improved panel and structural apparatus for enclosing apertures in a building structure which is economical to fabricate and erect.

Another object of our invention is to provide an improved apparatus for enclosing apertures or covering a building structure which reduces the thermal conductivity factor between the interior and exterior of the structure to a minimum value.

It is another object of our invention to provide improved apparatus for supporting and sealingly engaging panels to be disposed on the exterior of a building structure which is economically and easily erected and readily and easily disassembled for the replacement of panels or the like.

These and other objects of our invention will become apparent from a consideration of the appended specification, claims and drawings, in which—

FIG. 1 is an outside front elevational view of apparatus embodying the principles of our invention enclosing and supporting suitable panel members in the form of transparent glass, in an aperture in a building structure;

FIG. 2 is an enlarged sectional view of a portion of FIG. 1 taken along section line 2—2;

FIG. 3 is an enlarged sectional view of a portion of FIG. 1 taken along section line 3—3;

FIG. 4 is an enlarged perspective representation of the sectional view of FIG. 3;

FIG. 5 is a perspective front elevational view of the corner of a structure to which our invention has been applied to cover apertures and other portions of the structure;

FIG. 6 is an enlarged sectional view of a portion of FIG. 5 taken along section line 6—6;

FIG. 7 is an enlarged partial sectional view of a portion of FIG. 5 taken along section line 7—7;

FIG. 8 is an enlarged partial sectional view of FIG. 5 taken along section line 8—8; and

FIG. 9 is an enlarged partial sectional view of FIG. 5 taken along section line 9—9.

Referring now to the drawings in which like or similar elements are identified by like reference characters, our invention is shown embodied in FIGS. 1, 2 and 3 as a panel frame that is disposed in aperture 11 in a building structure 10 and in FIGS. 5—9 as a panel frame that is disposed on the surface of a building structure 10. In each of the two embodiments presented as illustrating preferred embodiments of our invention, the panel frames disposed around the periphery of each of the panels to be mounted in or on a structure are comprised of gutter members adapted to be mounted upon the structure, face members and T-block connectors disposed intermediate and insulatedly interconnectedly engaging the gutter and face members. Suitable panels are disposed intermediate sealing portions on the outer and inner portions on the gutter and face members respectively. As illustrated on the several views of the drawings, the gutter and face members may be utilized for sills, jambs, mullions and headers to completely enclose a panel member and the T-block connectors are utilized in each of these several uses of the gutter and face members.

Referring to FIGS. 1, 2, 3 and 4 of the drawings, a fragmentary portion of a building structure 10 is shown having an aperture 11 which defines a window opening in the structure. Our invention is shown disposed as a perimeter frame for supportively and sealingly engaging a pair of panel members 40 which are shown comprised of double insulated glass panel members having an inner panel 41 and an outer panel 42 which are parallelly spaced

apart by a peripheral spacer member 43 and which are further sealingly engaged by member 44 which would also extend around the entire periphery of panel 40.

In the enlarged sectional view of FIG. 2, a gutter member 20 and a face member 70 are shown installed on the bottom of aperture 11 as a sill and are further shown interconnected by T-blocks 50 which are in turn disposed underneath and in supportive engaging relationship with the lower portion of panel 40.

In the detailed enlarged sectional drawing of FIG. 3 and the fragmentary sectional and perspective view of FIG. 4, a gutter member 20 is shown disposed as a sill and includes a bottom portion 21 having a plurality of downwardly opening grooves 22; a connector portion shown generally by reference character 23, an inner end wall 30 and a top portion 31. Connector 23 is shown having an outer end 24 of substantially uniform thickness and an outwardly opening groove disposed therein. Proceeding toward the inner end of connector 23, there is shown an enlarged portion comprised of outwardly sloping or flaring portions 27 which terminate in an inwardly straight portion 28 disposed substantially perpendicularly to connector 23, and an inner end of substantially uniform thickness that in turn depends from the body of gutter member 20. The outer portion of top 31 is provided with a longitudinally extending outwardly opening groove 32 that is adapted to receive and retain a panel sealing member 33. Gutter member 20 is shown sealingly mounted on the bottom of aperture 11 in building structure 10 by suitable sealing compound 34 which may be adhesive in nature.

A face member 70 is shown having a top portion 71 having an inwardly opening longitudinally extending groove adapted to receive and engage a sealing member 73 that is shown in sealing engagement with the outer side of panel 40. Face member 70 further includes an end wall 74 and a connector portion 75, shown as having an inner portion 76 having substantially parallel top and bottom surfaces, an outwardly sloping portion 77, an inwardly sloping portion 78 and a further outer straight portion 79 having parallel top and bottom surfaces, that depends inwardly and substantially horizontally from end wall 74 of face member 70.

Gutter member 20 and face member 70 are shown removably interconnected by a thermal T-block connector indicated generally by reference character 50. T-block connector 50 may be comprised of, for example, plastic or other material possessing the necessary structural characteristics and possessing the characteristic of low thermal conductivity. Connector 50 is of generally elongated construction having a T-portion at its lefthand end in FIGS. 3 and 4 and further includes a laterally extending groove 53 at its inner end 52 that is shaped to be substantially complementary with respect to connector 23 on gutter 20. In similar manner, an outwardly opening laterally extending groove 59 is disposed at outer end 58 of T-block 50 and is of substantially complementary shape with respect to connector 75 on face member 70.

In particular, groove 53 is provided with an outwardly sloping portion 54 at its outer end, a laterally outwardly extending straight portion 55, an inwardly sloping portion 56 and a further inwardly disposed portion 57 having substantially parallel top and bottom surfaces. In similar manner, groove 59 has an inwardly sloping portion 60, an outwardly sloping portion 61, an inwardly sloping portion 65, a straight portion 62 having substantially parallel top and bottom surfaces and outwardly flaring portions 63 at the inner end thereof. Connector 50 is further provided with an upwardly extending panel engaging portion 64 which extends at an inward angle toward and into engagement with panel 40, and a downwardly extending portion in engagement with the adhesive 34 disposed on the sill portion of aperture 11 in structure 10.

In the above discussion, connector 23 and connector 75 and the corresponding grooves in 53 and 59, T-block 50

may also be described as asymmetrical and semi-symmetrical. The terminology employed will become apparent from a description of the operation of our invention set forth below, however, it may be noted at this point that end 52 of T-block 50 provides asymmetrical or substantially permanent engagement with portion 23 of gutter member 20 in that installation of T-block 50 by complementary engagement of groove 53 with connector 23 is substantially a one-way connection in that once the T-block is disposed in engagement with gutter member 20, removal thereof requires a great deal of force. Further, with respect to connector 75 on face member 70, engagement thereof with groove 59 in the outer end 58 of T-block connector 50 results in a supporting engagement that may be more readily or removably disconnected to allow removal of face member 70 for any purpose desired.

OPERATION

The installation and use of the apparatus shown in FIGS. 1, 2, 3 and 4 will be described only in connection with the sill portion of the perimeter frame shown in FIG. 1 as the header, jamb and mullion installation is substantially the same. In operation, it will be assumed that a building structure 10 is provided with a suitably shaped aperture 11. The aperture 11 is to be enclosed with, for example, panels of insulated glass 40 and the panel frame is to be disposed around the perimeter of the panel members within the aperture 11 instead of over an aperture or over an existing surface of a structure. In effecting an installation, the periphery of aperture 11 is coated with a suitable sealing adhesive type material and gutter members, such as 20, are attached to the inner periphery of aperture 11 over the adhesive sealing material through the use of suitable fasteners (not shown) which might take the form of screws extending through bottom portion 21 of gutter member 20 into structure 10. At the time a continuous gutter member has been installed completely around the inner periphery of aperture 11 and the gutter member of the mullion shown thereon has been suitably attached to the inside edges of the jamb gutter members, a plurality of spaced apart T-block connectors 50 are disposed on connector 23 on gutter member 20. Installation is effected by simply pushing T-block connectors 50 on to connector 23 into the position shown in FIGS. 3 and 4. It may be noted at this point that it is preferable to initially install the T-block connectors 50 on the sill portions only, after which the panel 40 may be suitably disposed in engagement with sealing member 33 on gutter members 20 and panel engaging portion 64 near the outer end of T-block connectors 50. Following this, the T-block connectors may be disposed on any headers, mullions and jambs to retain the panel in the desired position. Face members 70 may then be easily installed in the disposition shown with sealing portion 73 in sealing engagement with panel 40 and connector 75 in operative engagement with the lateral groove 59 in the outer end of T-block connector 50.

Referring now to FIGS. 5, 6, 7, 8 and 9, our invention is shown embodied in an installation which is disposed on the exterior of a structure 10 as distinguished from the embodiment described above. Referring to FIG. 5 of the drawing, there is shown a corner of a structure 10 that is substantially enclosed and covered by a plurality of panels 12 which are supported and held in place on the exterior of the structure through the use of gutter members, face members and T-block connectors embodying the principles of our invention. While there is shown a sill, header and jamb configuration which surrounds the perimeter of the panels installed on the structure, it will be apparent from a consideration of the above-noted figures of the drawings that the perimeter framing is not disposed within an aperture, such as aperture 11 on FIG. 1 of the drawings.

Referring again to FIG. 5, it may be appreciated by those skilled in the art that panels 12 may be in part, or

5

in toto opaque or transparent depending upon the desires of the architect or designer insofar as modifying the appearance and improving the utilitarian aspects of any given structure, such as structure 10. The several elements in the composite structure shown in FIG. 5 are indicated generally as a header element 90, a sill element 91, jamb elements 92, and mullion elements 93 all of which combine to simultaneously engage and support the individual panel elements 12 on the surface of structure 10.

Referring specifically to FIG. 6, a cross-sectional view taken along section line 6—6 of FIG. 5 of the drawings includes a header gutter 84, a pair of mullion gutters 82 and a sill gutter 20, each of which is securely fastened to the outer face of structure 10 through suitable fastening means, for example, screw threaded bolts or the like. A like number of face elements, illustrated as header face 85, mullion faces 83 and sill face 70 are shown removably connected to the respective gutter elements through T-block thermal connector members 50 which are disposed in the relative position shown for supportively engaging panel members 12 and the indicated face members. Further shown on FIG. 6 are a jamb gutter and face 80 and 81 respectively which may be suitably attached to and in engagement with the header, mullion and sill elements noted above.

Referring specifically to FIG. 7 of the drawings, an enlarged sectional view taken along section line 7—7 on FIG. 5 of the drawing illustrates the respective configuration and relationship of a jamb gutter 80, a jamb face 81, a T-block connector 50 and a pair of panels 12 in an illustrative embodiment for a corner jamb, column or post. FIGS. 8 and 9 illustrate the respective configurations and relationship of elements for gutter, face and T-block connectors in connection with a mullion and sill element respectively.

As may be seen in, for example, FIGS. 3, 4, 7, 8 and 9, longitudinally elongated connector members 23 extend laterally outwardly of the gutter members from which they depend. In all illustrations, the outermost end extends at least partially past the inner face of the panel member, thus effectively presenting a barrier that is substantially impervious to the flow of liquid therethrough.

Having now therefore fully illustrated and described our invention, what we claim to be new and desire to protect by Letters Patent is:

1. In apparatus of the class above described, the combination, comprising; at least one longitudinally elongated gutter member; a like number of longitudinally elongated face members, each of said members being dimensioned to be disposed in spaced apart relationship upon a structure and each of said members having a longitudinally elongated portion extending toward the other of said members in generally lateral registration therebetween, said gutter member being disposed toward the interior of said structure and including a continuous laterally extending lower portion adapted to be disposed to extend toward the exterior of the structure underneath longitudinally elongated portion thereof; a plurality of longitudinally spaced apart thermal connector members, each of said thermal connector members having a first end for permanently, engaging and mounting the same upon the longitudinally elongated portion of said gutter member, and a second end for removably receiving and supportively engaging the longitudinally elongated portion of said face members; and means mounting said gutter member upon said structure whereby said face member is removably disposed and mounted in laterally spaced apart relationship with respect to said gutter member and a panel member may be removably secured therebetween.

6

2. In apparatus of the class above described, the combination, comprising; at least one longitudinally elongated gutter member; a like number of longitudinally elongated face members, said members adapted to be disposed in spaced apart relationship upon a structure whereby a panel member may be removably secured therebetween and each of said members having a longitudinally elongated portion extending toward the other of said members in generally lateral registration therebetween, said gutter member being disposed toward the interior of said structure and the longitudinally elongated portion thereon extending toward said face member under at least a portion of said panel member so as to present a continuous lateral cross section adapted to prevent the flow of liquid there-through when disposed upon a structure; a plurality of thermal connector members, each of said thermal connector members having a first end for permanently engaging and mounting the same upon the longitudinally elongated portion of said gutter member, and a second end for removably receiving and supportively engaging the longitudinally elongated portion of said face member, said connector members being disposed in longitudinal spaced apart relationship intermediate said gutter and face members; and means mounting said gutter member upon said structure whereby said face member is removably disposed and mounted in laterally spaced apart relationship with respect to said gutter member so that said panel member may be removably secured therebetween.

3. The apparatus of claim 2 in which the gutter member further includes means for engaging a panel, said means being disposed inwardly of the end of the longitudinally elongated portion thereof.

4. The apparatus of claim 3 in which the first end of the thermal connector member and the longitudinally elongated portion on the gutter member are of complementary shape.

5. The apparatus of claim 2 in which the thermal connector members include a panel engaging surface extending upwardly and inwardly of the second end of the thermal connector members.

6. The apparatus of claim 1 in which the first end of the thermal connector member and the longitudinally elongated portion on the gutter member are of complementary shape.

7. The apparatus of claim 1 in which the thermal connector members include a panel engaging surface extending upwardly and inwardly of the second end of the thermal connector members.

8. The apparatus of claim 1 in which the gutter member further includes means for engaging a panel, said means being disposed inwardly of the end of the longitudinally elongated portion thereof.

References Cited

UNITED STATES PATENTS

2,835,360	5/1958	Bernardoni et al.	52—403
2,933,779	4/1960	Delaroche	52—403 X
3,016,993	1/1962	Owen	52—397
3,093,217	6/1963	Doede	52—397 X
3,191,727	6/1965	Schmeltz et al.	52—403
3,242,625	3/1966	Tillinghast	52—461
3,393,487	7/1968	Nolan	52—403
3,403,490	10/1968	Luedtke	49—504 X
3,308,588	3/1967	Von Wedel	52—402 X

PRICE C. FAW, JR., Primary Examiner

U.S. Cl. X.R.

49—504; 52—403, 476, 616