

Aug. 25, 1970

G. M. GROVER

3,525,386

THERMAL CONTROL CHAMBER

Filed Jan. 22, 1969

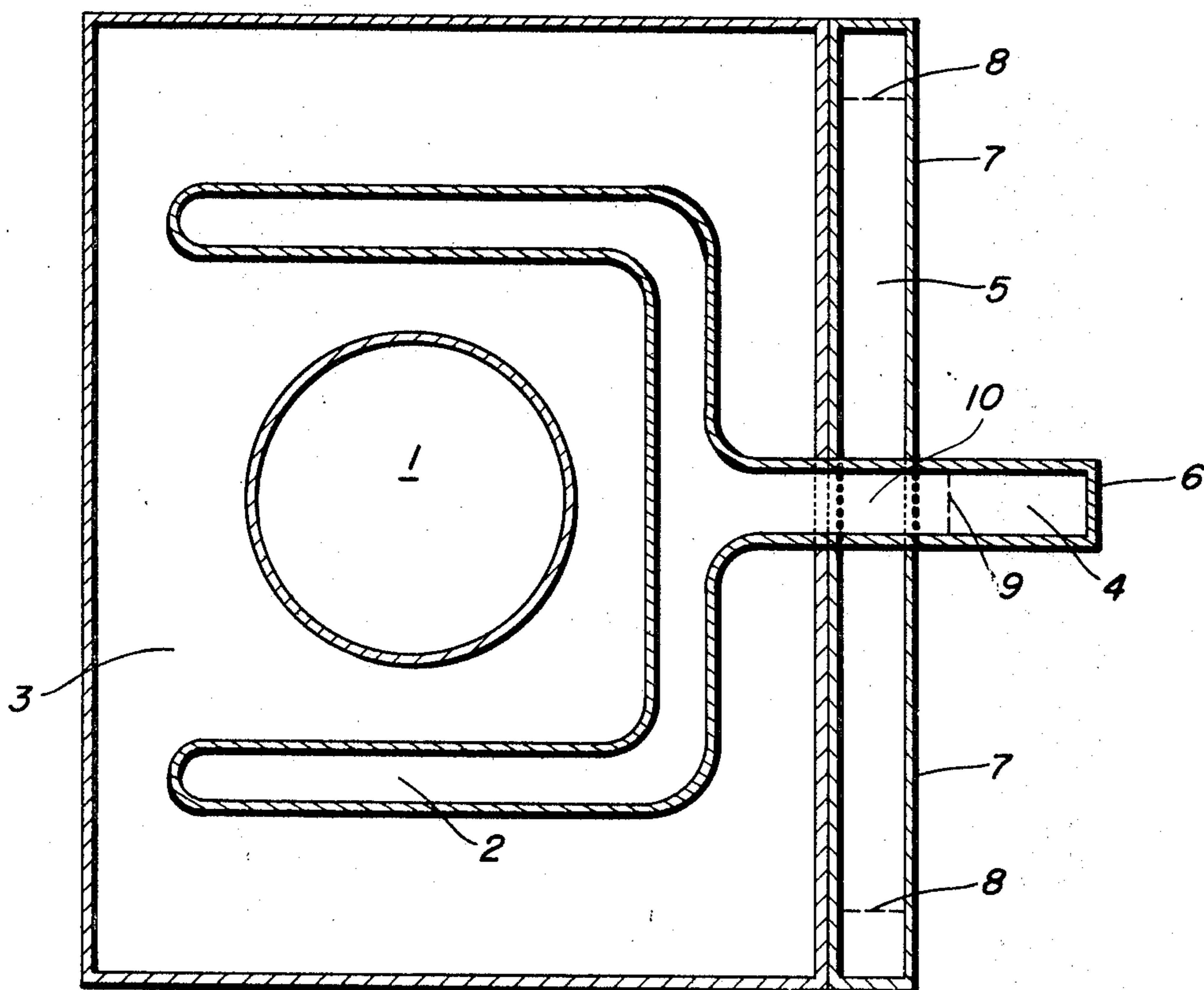

INVENTOR.  
George M. Grover

BY

*Ronald A. Groves*  
attorney

1

3,525,386

## THERMAL CONTROL CHAMBER

George M. Grover, Los Alamos, N. Mex., assignor to the United States of America as represented by the United States Atomic Energy Commission

Filed Jan. 22, 1969, Ser. No. 793,042

Int. Cl. G05d 23/00; F28d 15/00

U.S. Cl. 165—32

5 Claims

### ABSTRACT OF THE DISCLOSURE

A device for maintaining an enclosure containing a heat generating body at a constant temperature even though the quantity of heat generated by said body varies. A first heat pipe transfers heat to a second heat pipe through a surface common to both heat pipes and the heat is radiated away by the second heat pipe.

The invention described herein was made in the course of, or under, a contract with the U.S. Atomic Energy Commission.

This invention relates to temperature control in a chamber housing a heat source which generates variable quantities of heat. This invention may be employed in conjunction with a battery or fuel cell which generates a variable quantity of heat depending upon the electrical power being withdrawn. During periods of heavy power requirements heat must be radiated away to keep the unit from overheating and during light power loads little or no heat needs to be radiated away.

To control the heat dissipation prior art devices have employed radiators including mechanical shutters for covering the radiators during periods of low power requirement. However, this solution has drawbacks because the shutter system is complex and unreliable.

It is therefore an object of this invention to provide a reliable and yet relatively uncomplicated device for controlling the heat exchange between a heat generating body and the outside.

Heat pipes of the type described by Grover, Cotter and Erickson in "Structures of Very High Thermal Conductance," Journal of Applied Physics, vol. 35, 1900 (June 1964) have established themselves as efficient and reliable heat transfer devices. This invention employs two heat pipes with a common section of wall between them. The first heat pipe transports heat to the common wall and it is transported and radiated to the outside by the second heat pipe.

The first heat pipe contains an inert gas as well as a condensable working fluid. The inert gas is pumped to the condenser end of the pipe (the end farthest from the heat source) and compressed until the pressure of the inert gas equals the pressure of the vapor of the working fluid. If the heat supplied to the evaporator end of the pipe (the end nearest the heat source) changes, two effects are noticed. First, the temperature of the pipe increases slightly. Second, the inert gas is compressed further because the vapor pressure of the working fluid is increased. This causes an increase in the active volume of recirculating heat pipe working fluid and, consequently, an increase in the radiating area. Thus an additional heat input causes both an increase in radiating area and a small increase in pipe temperature. When the volume of inert gas is relatively large, only a small change of temperature would cause a relatively large change of radiating area. Hence, the temperature change can be relatively small for large change in the heat input to the pipe.

If the first heat pipe could only get rid of its heat by radiation then the change in the size of the radiating

2

area would represent the limit of control. By coupling the first heat pipe to a second heat pipe by conduction through the thin common wall, much greater quantities of heat can be controlled. When the first heat pipe's active area does not reach the common wall, very little heat is removed from the system. With a small increase in area so that the second heat pipe is brought into the system, very much larger quantities of heat can be dissipated. This change is accomplished with only a small movement of the vapor-gas interface and consequently requires only a small increase in inert gas pressure in the first heat pipe. This means that the temperature change in the first heat pipe is very small between the two extreme cases of very little heat input to very large heat input. The double heat pipe arrangement acts something like a "radiating area amplifier," thus providing closer control of the input temperature.

The above and other objects and advantages will be made apparent from a consideration of the accompanying drawing wherein the single figure shows a side view of applicant's invention operably connected to a heat generating source such as a fuel cell.

When heat is generated in fuel cell 1, the heat is transferred to the heat pipe 2 which will be designated the "primary" heat pipe. This heat pipe consists of an enclosed container lined with capillary "wicking," partially filled with a working fluid and partially filled with an inert gas. The heat absorbed causes evaporation of the working fluid and pumps the inert gas into the attached stem 4 of the primary heat pipe. Until the temperature of the primary heat pipe reaches the design value, heat is lost only by conduction through the insulation 3. As the temperature approaches the design value, the vapor pressure forces the inert gas further into the stem 4 and the vapor-gas interface 9 moves toward surface 6. This action exposes the common wall 10 between the primary heat pipe 2 and the secondary heat pipe 5 to the working area of the primary heat pipe. Condensation occurs on the common wall 10 transferring the latent heat of condensation to the secondary heat pipe which sets the secondary heat pipe into operation. The secondary heat pipe transfers the heat from the evaporator section near the common wall 10 to the condenser section and the heat is radiated to the outside at surface 7.

The exact quantity of inert gas necessary for proper operation of the primary heat pipe depends on the desired temperature to be maintained in the battery compartment. For instance, if it is desired to hold the temperature at 100° C., and if water is the working fluid, a quantity of gas is initially admitted such that the pressure of the compressed gas in the stem is 760 torr when the common wall 10 is exposed to the circulating working fluid of the primary heat pipe. Since the volume of the stem under the common wall 10 can be made small relative to the total volume of the stem, the pressure in the stem and hence in the working fluid will remain approximately at 760 torr.

The secondary heat pipe 5 is shown in the form of a circular container. The secondary heat pipe may be filled with an inert gas which will be compressed radially outward with an increased heat input through the common surface 10, thus causing the interface 8 to move radially outward exposing more radiating surface 7. In addition, other heat pipes may be connected to the second heat pipe in the same manner the second heat pipe was connected to the first in order to further increase the radiating area.

Various working fluids may be employed with this invention. For instance, using 1,1,1,2-tetrachloroethane, the working pressure would be about 350 torr at 100° C., but since the freezing point is -68.7° C., the risk of freezing the working fluid is much less than when using water.

3

This invention has special utility in connection with space craft. Heat pipes have been shown to work successfully in space. The durability and reliability of the invention are of major importance when used in conditions making repair and servicing impossible.

What I claim is:

1. A device for maintaining a heat generating body at a constant temperature comprising a first enclosed container partially surrounding the heat generating body and a second enclosed container connected to the first container by a common wall at a point remote from the heat generating body, said first container having a portion extending beyond said common wall, both of the containers being lined with a capillary material and partially filled with a condensable working fluid and partially filled with an inert gas, the ratio of the quantity of said working fluid to the quantity of said inert gas being selected so that said working fluid is in contact with at least a portion of said common wall only at a predetermined operating temperature and higher temperatures.

2. The device of claim 1 wherein the second container is circular.

4

3. The device of claim 1 wherein the condensable working fluid is water.

4. The device of claim 1 wherein the condensable working fluid is 1,1,1,2-tetrachloroethane.

5. The device of claim 3 wherein one or more enclosed containers, each lined with a capillary material and filled with a condensable working fluid and an inert gas, are connected to the second container and to the next succeeding container by a common wall in chain fashion.

#### References Cited

##### UNITED STATES PATENTS

3,378,449	4/1968	Roberts et al. -----	165—105 X
2,581,347	1/1952	Backstrom -----	165—105 X
1,754,314	4/1930	Gay -----	165—105 X

ROBERT A. O'LEARY, Primary Examiner

A. W. DAVIS, JR., Assistant Examiner

U.S. Cl. .XR.

136—181; 165—105