

Nov. 12, 1968

E. HAAS

3,410,455

DISPENSING DEVICE FOR TABLETS

Filed Dec. 13, 1966

FIG. 1.

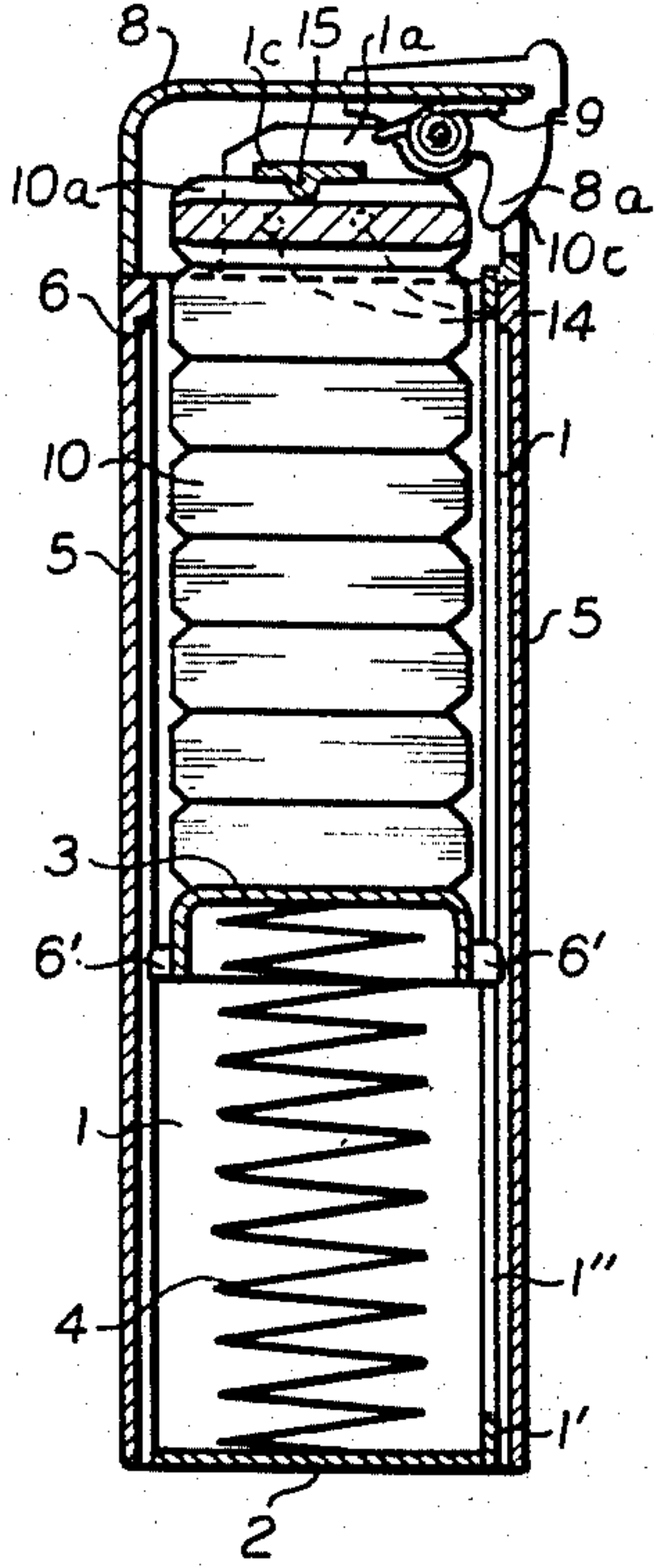

FIG. 2.

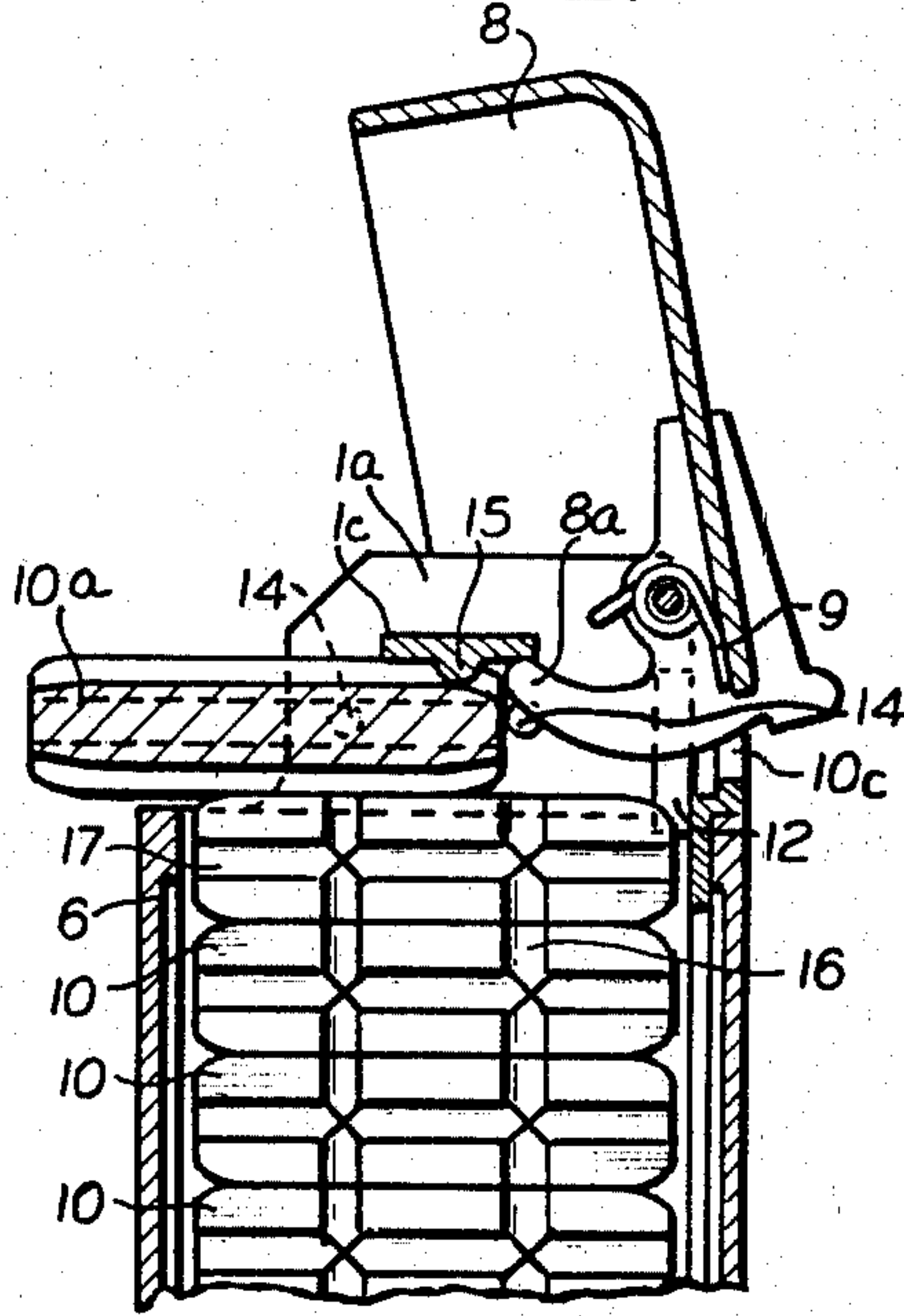

FIG. 3.

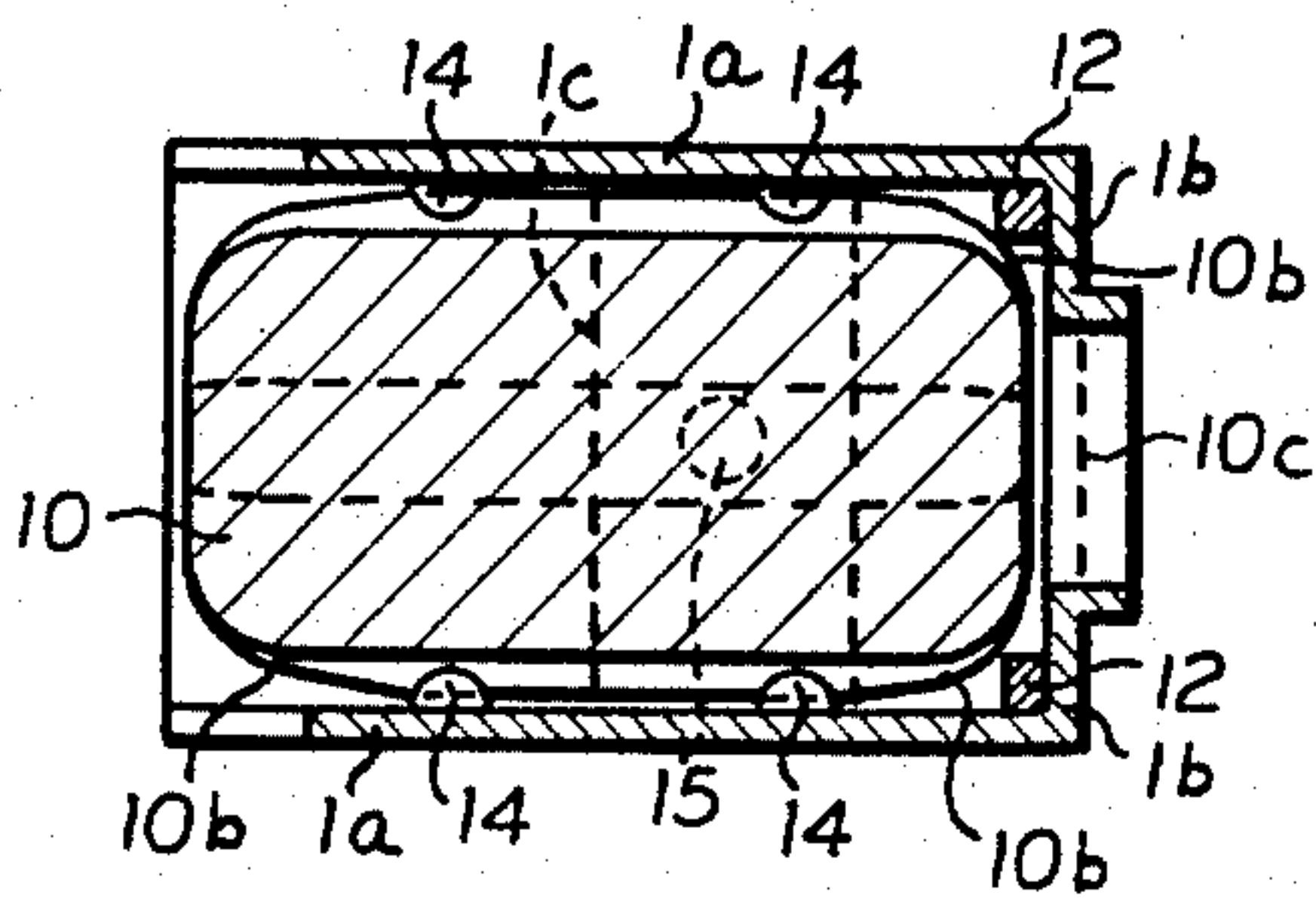

FIG. 4.

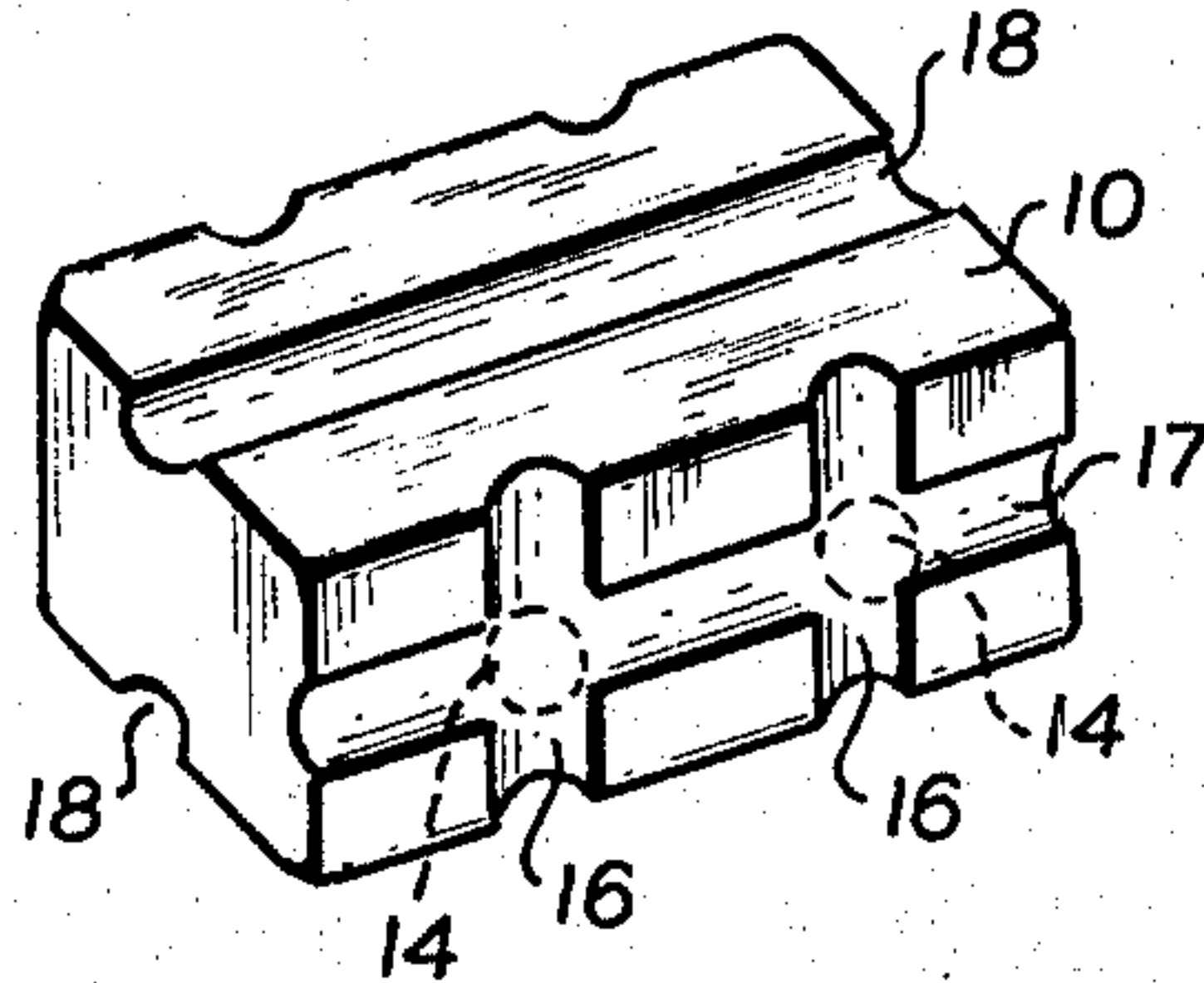

FIG. 5.

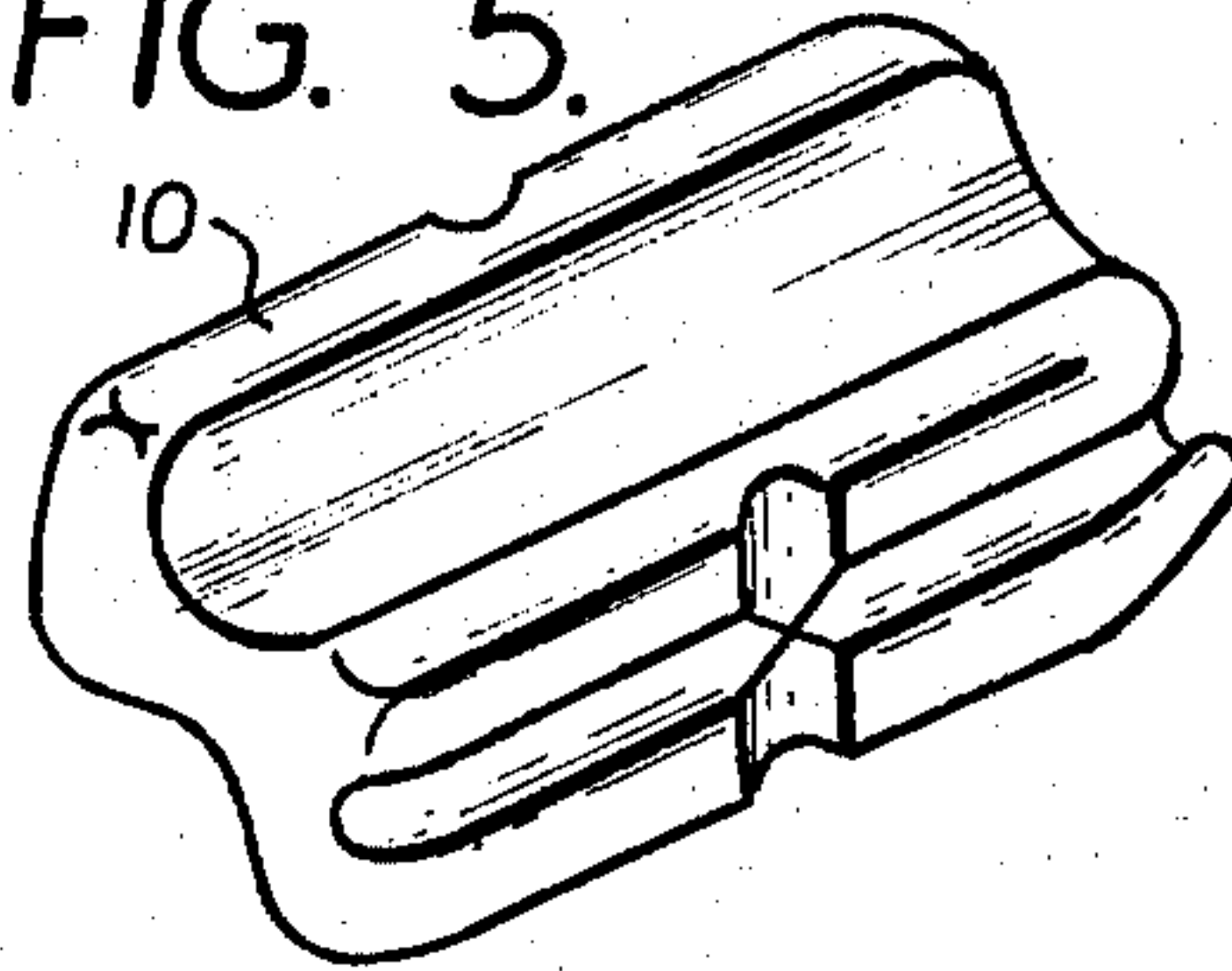
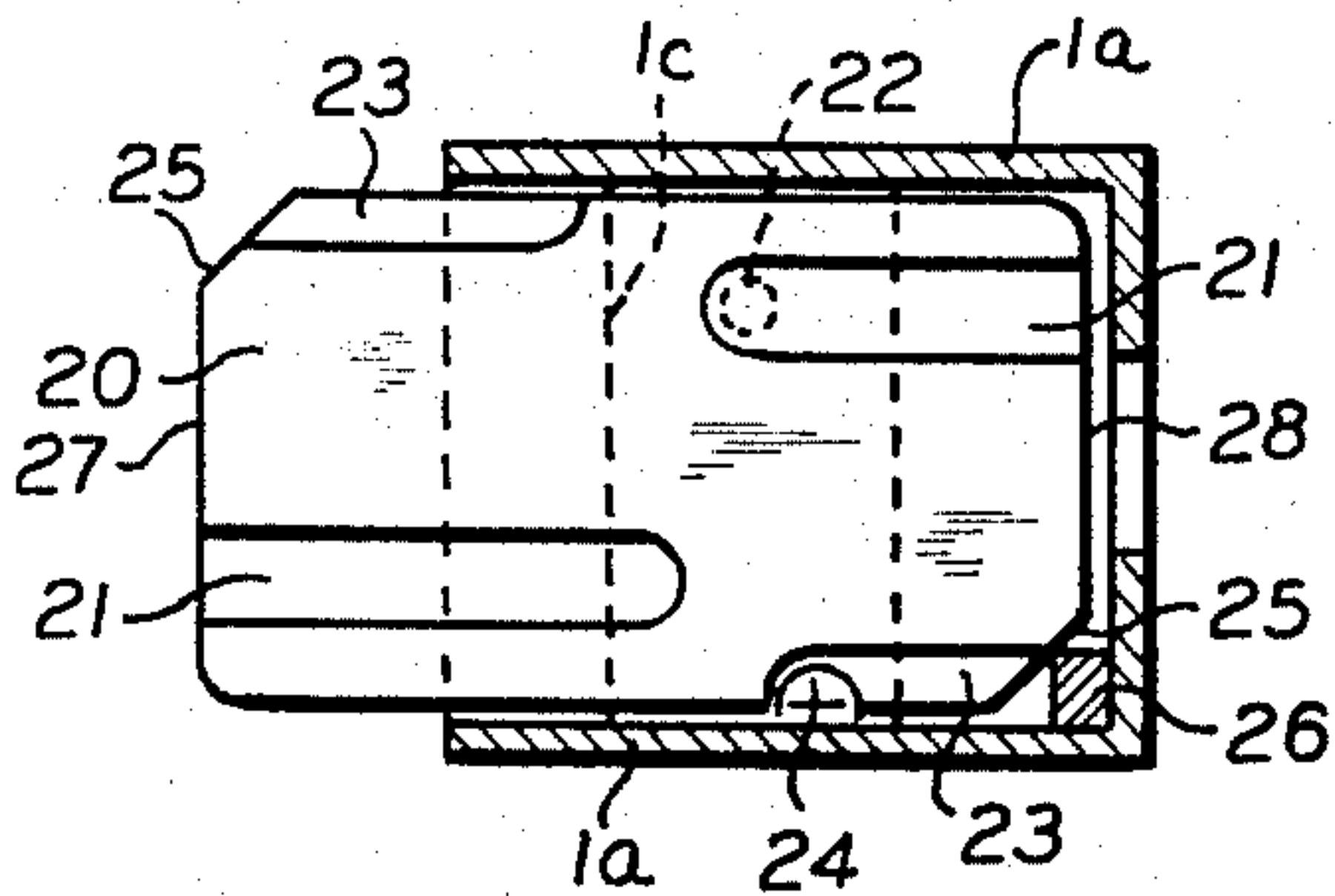

FIG. 6.



INVENTOR
EDUARD HAAS

BY

Invent Montage

ATTORNEY.

1

2

3,410,455

DISPENSING DEVICE FOR TABLETS

Eduard Haas, Vienna, Austria, assignor to Centromint Company (Establishment) Vaduz, Liechtenstein, a corporation of Liechtenstein

Filed Dec. 13, 1966, Ser. No. 601,520

Claims priority, application Austria, Dec. 30, 1965,

A 11,775/65

5 Claims. (Cl. 221—229)

ABSTRACT OF THE DISCLOSURE

A dispensing device for tablets of longitudinal shape, particularly of prismatic configuration, comprising a housing adapted to receive a plurality of tablets in the form of a pile, the tablets constituting a first member, the housing having a bottom and an intermediate bottom disposed in the housing intermediate its open upper end and the bottom, spring means disposed between the intermediate bottom and the bottom of the housing and urging the intermediate bottom to its uppermost position, and the housing defining a tablet receiving range and in its upper position a dispensing range adapted to dispense the uppermost of the pile of tablets disposed substantially in the tablet receiving range. A cover member is provided swingably mounted on top of the housing and the cover includes the sliding-out member entering the dispensing range upon swinging the cover member from its housing-closing position to its open position. The dispensing range of the housing is defined by at least three walls, constituting second members and dispensing laterally the uppermost of the tablets in the direction perpendicular to the direction of movement of the tablets in the pile and at least one of the members has at least one projection extending into the dispensing range of the projection and is adapted to be received by a complementary recess of the other of the members, so that having no recesses cannot be dispensed by the device.

The present invention relates to a dispensing device for tablets, in general, and to a dispensing device for such tablets of longitudinal shape, in particular, preferably those with a prismatic outer face, which comprises a hollow gripping portion, which is adapted for the reception of a pile of tablets. The pile of tablets is displaced by means of a spring biased pressure plate towards the dispensing range, from which always the upper most tablet of the pile is moved outwardly at a right angle to the direction of feeding from the device by means of a manually operated moving member and, thereby, slides along three sides on the walls of the sliding-out range.

Dispensing devices of this type have found broad application to a high degree, in the past years, which can be explained not the least by the fact that the original tablets for the dispensing in these devices respond to the highest quality requirements. To the extent, these dispensing devices have been accepted, attempts have been made to put on the market refill packages, which lend themselves to work with the introduced dispensing devices, that means they are capable of an individual dispensing of the tablets, which, however, do not live up to the standard of quality, to which the user by the original tablets is acquainted and which users the producer of the dispensing devices intends to satisfy, because, otherwise, such dispensing devices, as a whole, obtain bad reputation. For these reasons it is desirable to design the dispensing device such that it is capable of dispensing peculiarly formed tablets. The presently known and marketed tablets are more or less simple prismatic bodies with rounded edges and their advance in and discharge from the dispensing device is thus performed smoothly. If, however,

a shift takes place to tablets of a more complicated configuration, for instance with convex curved outer faces, cut-in grooves in side faces thereof, or the like, the difficulty is created, to maintain the tablets in the discharge range of the dispensing device in the correct position also relative to the limiting walls of this range, in order to avoid an oblique position of the tablets, and thereby to annoying discharge difficulties.

It is now one object of the present invention to provide a dispensing device of the above-stated type, wherein these devices cannot be used easily in connection with tablets, which due to their simple, that means slightly individual form, practically can be imitated by everybody, that means, thus, to protect better the user against such not original refill goods, but to assure, on the other hand a safe dispensing of such tablets from the dispensing whereby in such dispensing device of the mentioned type, the sliding-out range is equipped with at least one projection which, during performance of the movement with which the tablet reaches the sliding-out range and/or with which it is slid out from this range, grips in corresponding groove-like wall recesses of the tablets, whereby the shape of the groove permits a complete dispensing of the tablet from the sliding-out range. It is to be understood that the term "sliding-out range" is that range of the device into which always the uppermost and thus the tablet ready for the next sliding-out process enters, and in which the sliding-out mechanism is operating.

It is another object of the present invention to provide a dispensing device for tablets, wherein the projection may comprise substantially a thumb, which joins the movement with a closing cover and which, upon swinging out of this cover for the purpose of removing of a tablet, the uppermost tablet slides out from the stack away and out of the device to an extent that it can be gripped. Upon removal of this uppermost tablet, space is created in the sliding-out range, which is assumed by the following tablet, because the storage stack or pile is under spring pressure and, therefore, the tendency exists to deliver always the uppermost tablet of the stack into the sliding-out range, where the tablet abuts a stay bridging this range. Upon returning the cover into the normal closing position, the following slide process takes place in the dispensing device referred to above, and consequently, the releasing thumb has withdrawn from the sliding-out range. If now the tablet has a shape appreciably deviating from the prism shape and if it is equipped with convex faces or a cut-in, this point-like cooperation with the releasing thumb is insofar causing difficulties, as slight eccentricities cause the tendency to an oblique position of the tablet and thus to a clamping during the slide-out process. The projection according to the present invention, which extends into the slide-out range and cooperates with a groove of the tablet, provides an additional guide for the tablet, which reduces extensively the danger of wedging.

It is still another object of the present invention to provide a dispensing device for tablets which, in a particular simplified embodiment, has two projections in the release range, which projections are arranged in the rear edge ranges of the release range extending opposite to the releasing opening and in the sliding-in direction and comprise in particular preferably ribs following these edge ranges. In such case, tablets will be used, which are recessed at least in the range in which the ribs are disposed, when the tablet has reached the sliding-out position. Otherwise, it would not be possible to bring the tablets into the sliding-out range. These recesses constitute, in their simplest arrangement, rounded-off portions of the narrow sides of the tablets and suitably they will be provided on all four shortest sides, in order not to render more difficult the refilling of the dispensing device due to

the fact that the pile of refill tablets can be inserted into the device only in one of two possible positions.

It is yet another object of the present invention to provide a dispensing device for tablets, wherein a plurality of projections are distributed in the sliding-out range such, that the wall recesses of the tablets, which are required in order to pass the latter past the projections, assume the form of grooves extending throughout at least one side face. One obtains in this manner tablet forms, which are impressed in the memory of the user, due to its peculiar form, and for which the producer can develop a corresponding advertising campaign without losing any protection. The imitation of this particular tablet form by unauthorized persons will then be considered as a step violating the basic rules of unfair competition. Thus, the users can count more than up to now to be protected of inferior imitations or even of such imitations of equal value of the original products, whereby, on the other hand, the producer of the original product may count less than until now that he builds up at first a distribution for his quality products at high costs, particularly high advertising costs, and that then the imitations appear on the market.

With these and other objects in view which will become apparent in the following detailed description, the present invention will be clearly understood in connection with the accompanying drawings, in which:

FIGURE 1 is a longitudinal section of a dispensing device with closed cover and designed in accordance with the present invention;

FIG. 2 is a fragmentary section, shown at enlarged scale, of the dispensing device disclosed in FIG. 1, particularly showing the upper portion thereof and the cover being in its open position;

FIG. 3 is a bottom cross-sectional view of the device disclosing particularly the sliding-out range of the device disclosed in FIG. 1, with the tablet still fully inserted therein;

FIG. 4 is a perspective view of a tablet used in connection with the dispenser disclosed in FIG. 1, the basic form of the tablet showing a plurality of grooves extending over a plurality of outer faces;

FIG. 5 is a perspective view of another embodiment of a tablet to be used in connection with the dispensing device disclosed in FIG. 1; and

FIG. 6 is a top sectional view of another embodiment of the sliding-out range of the present invention.

Referring now to the drawings, and in particular to FIGS. 1 and 2, a dispensing device for tablets is disclosed, as is known in its basic structure from the Patent No. 2,620,061, dated Dec. 2, 1952. It comprises a housing 1 having a bottom 2 and an intermediate bottom 3 axially displaceable in the housing 1, which intermediate bottom 3 is biased by a helical spring 4, which is disposed between the bottom 2 of the housing 1 and the intermediate bottom 3 and aims to displace the intermediate bottom 3 in upward direction.

The housing 1 has, in addition to its bottom 2, three side walls, namely a front wall, a rear wall and a right side wall 1' having a vertical slot 1'', receiving a projection 6' extending laterally from the intermediate bottom 3 into the slot 1'' and is guided therein during the axial displacement of the intermediate bottom 3 in the housing 1.

In order to fill the dispensing device, somewhat deviating from the structure disclosed in said U.S. patent, a shell 5 surrounding the housing 1 is provided, which shell 5 is open at its bottom and affects the intermediate bottom 3 by means of an inwardly directed shoulder or flange 6 which engages or abuts a projection 6', upon downward movement of the shell 5 relative to the housing 1, until the shoulder 6 engages the projection 6', and, thereby, slides the intermediate bottom 3 likewise downwardly, simultaneously tensioning the helical spring 4. The open narrow side of the actual housing 1 is now

freed for insertion of the pile of tablets. A swingable cover 8 is rotatably mounted in lugs 1a of the housing 1 at the upper end of the dispensing device and is swingable into the position shown in FIG. 2 against the force of a spring 9, whereby the uppermost tablet 10a of the pile 10 of the tablets slides out laterally into the position shown in FIG. 2 of the drawings. In order to bring about this result, the cover 8 is equipped with a thumb 8a and the latter enters during the mentioned swinging movement of the cover 8 into the uppermost range of the housing 1, namely into the dispensing range. If the cover 8 is released, the uppermost tablet 10a is now lifted by the spring 4 into the dispensing range. This dispensing range is defined by the upper projections 1a of the housing 1 and the rear wall 1b, which has a slot 10c permitting the passing of the thumb 8a therethrough, and by an abutment ledge 1c.

The particular design of the dispensing range designed in accordance with the present invention is as follows:

Projections extend into the dispensing range, which projections stand off the walls defining this range and which cooperate with corresponding recesses of the tablets. By such arrangement, it is brought about that the tablets which do not have these recesses cannot be dispensed from this dispensing device. It is of course also possible to reverse the arrangement of the projections and recesses, respectively, which projections and recesses constitute complementary elements.

In their simplest structure, these projections comprise ledges 12, which are provided in the corners of this range. These ledges 12 are formed preferably integrally with the walls 1a, 1b and simultaneously fortify the edge range. In order to dispense now a tablet 10 in spite of the presence of these edge fortifications from the dispensing device as shown, the tablet must have corresponding clear recessed corner ranges, that means, they must be equipped with a correspondingly strong rounded-off portion 10b. The rounded portions are provided suitably on all four narrow edges of the tablet, in spite of the fact that it would suffice to provide the rounded-off portions only on the two edges of a narrow side, namely that which is opposite the housing side 1b. In particular, this multiplicity of rounded-off portions or recesses 10b is provided for the purpose of obtaining symmetrical tablets, so that upon refilling of the dispensing device, no particular attention has to be paid as to which end of the tablet is inserted, since otherwise, the refill pile could be inserted only in one of two possible positions into the dispensing device, in order to render the dispensing device operable.

One recognizes that tablets, which have a prismatic outer face corresponding to the tablet 10, however, would not fit in a shown dispensing device without edge roundings, since they would fit in the storage space, but not in the dispensing range, unless its total measurements are correspondingly reduced, in which case a proper function of the device is questionable. It is furthermore recognizable that the projections 12 extend through the entire height of the housing 1, in which case the above-stated not rounded-off tablets would not fit any more in this housing, yet, however, the presence of the projections 12 suffices in the dispensing range only in order to bring about the desired result.

The basic concept of the invention disclosed so far permits embodiments of which in particular one is disclosed in FIG. 4. In FIGS. 2 and 3, additional projections 14 and 15 are shown which are disposed either in the end ranges 1a of the side walls partly at the abutment ledge 1c, and which cooperate with corresponding recesses of the tablets. A tablet intended for this arrangement of the projections 14 and 15 is shown in FIG. 4. The grooves 16 cooperate with the projections 14 if the tablet 10 is lifted into the dispensing range, which is the case, as soon as a tablet has been removed from this dispensing range and the cover has resumed again the

closing position, as shown in FIG. 1. If the following tablet has reached the dispensing range, the projections 14 will assume a predetermined relative position concerning the side faces of the tablet, which is shown in FIG. 4 in dotted lines. If now the tablet by opening the cover 8 is to be removed, it must be displaced towards the left in the direction towards the releasing- and removal-opening, respectively, as shown in FIG. 2. In order that this displacement movement is not made impossible by the tablet, the tablet must be equipped with an additional recess 17, in which the projections 14 can move relative to the tablet, if the latter performs the mentioned movement towards the left.

A further projection 15 is, as set forth above, provided on the bottom side of the ledge 1c. It can now be readily determined, that this projection 15 requires a channel 18 in the tablet, otherwise the tablet could not be brought into the right position relative to the abutment ledge 1c and could also not be correctly moved out. It would suffice if the channels 17 and 18 would extend from the center up to the right end of the tablet as shown in the drawing, however, for the above-stated suitability of the preparing of symmetrical tablets, these channel-like recesses 16, 17 and 18 extend over the entire faces of the tablets.

One realizes now, that the concept of the present invention makes possible a great number of different tablet forms. Depending upon the arrangement, shape and number of the projections which cooperate with the tablet during the insertion of the tablet into the displacing range of the housing and during the removal from this range. FIG. 5 discloses a tablet form which has a configuration complementary to a wide projection which is arranged on the bottom side of the ledge 1c, and also a narrow projection which is to be provided on the inside of the wall parts 1a. Furthermore, the tablet is equipped with strong rounded-off ranges, in order to effect working in these ranges projections of the type of the projections 12, as shown in FIGS. 2 and 3.

It should be remarked, that the requirement for providing symmetrical tablets is not to be understood in a completely strong sense. It suffices central symmetry, as shown in FIG. 6, in one example, the showing being similar to that of FIG. 3, in which the large top faces of the tablet 20 have two recesses 21 for the cooperation with a projection 22 of the ledge 1c, two side recesses for cooperation with a projection 24 of the wall 1a and two inclinations 25 for cooperation with a corner projection 26 and whereby all projections are disposed one-sided. One recognizes that, regardless with which of the end faces 27 or 28 at the front a pile consisting of such tablets is inserted into the dispensing device, the latter is always ready to release tablets of this type by normal operation of the cover.

Finally, it should be remarked that the application of the present invention, as it has been described in connection with the dispensing device of the type disclosed in FIGS. 1 and 2, is not limited to such dispensing devices, nevertheless. Generally, the invention is applicable in such devices with particular advantage, in which one tablet is moved from a storage pile into a release chamber and moved out from the latter with simultaneous change of direction of movement by some mechanism. In this case, one can, as already shown, arrange the projections such, that the corresponding recesses provided in the tablets complement each other to composed figures, for instance, in angular shape of in cross- or double-cross-shape. If, as is the case in FIG. 5, these projections have unequal measurements, one obtains particularly characteristic tablet forms. To bring the latter into a functional connection with the dispensing device, is the particular purpose of the present invention.

While I have disclosed several embodiments of the present invention, it is to be understood that these embodiments are given by example only and not in a limiting

sense, the scope of the present invention being determined by the objects and the claims.

I claim:

1. A dispensing device for tablets of longitudinal shape, particularly of prismatic configuration, comprising:
 - a housing adapted to receive a plurality of tablets in form of a pile, said tablets constituting a first member,
 - said housing having a bottom and an intermediate bottom disposed in said housing intermediate its open upper end and said bottom,
 - spring means disposed between said intermediate bottom and said bottom of said housing and urging said intermediate bottom to its uppermost position,
 - said housing defining a tablet receiving range and in its upper portion a dispensing range adapted to dispense the uppermost of said pile of tablets disposed substantially in said tablet receiving range,
 - a cover member swingably mounted on the top of said housing,
 - said cover member including a sliding-out member entering said dispensing range upon swinging said cover member from its housing-closing position to its open position,
 - said dispensing range of said housing being defined by at least three walls and dispensing laterally the uppermost of said tablets in a direction perpendicular to the direction of movement of said tablets in said pile, at least one of said walls constituting a second member, and
 - at least one of said members having at least one projection extending into said dispensing range and said projection being adapted to be received by a complementary recess of the other of said members, so that tablets having no recess cannot be dispensed by said device.
2. The dispensing device, as set forth in claim 1, wherein:
 - said members have complementary elements,
 - said dispensing range has two complementary elements disposed in the rear edges of said dispensing range extending in the feeding direction of said pile of tablets and opposite the dispensing opening of said dispensing range, and
 - said two complementary elements are ribs following said edges.
3. The dispensing device, as set forth in claim 2, comprising in combination:
 - said housing with tablets received therein,
 - said tablets have at least one of said complementary elements extending along the entire length of at least one side face of said tablets, and
 - a cooperating other of said complementary elements on said dispensing range slidably positioned in said at least one of said complementary elements when said tablet is being dispensed, permitting the dispensing of said tablet.
4. The dispensing device as set forth in claim 3, wherein:
 - said tablet includes a vertical complementary element extending perpendicularly up to said at least one other complementary element and aligned, when said tablet is in said device with, said cooperating other of said complementary elements to slidably permit the latter to enter said at least one other of said complementary elements during dispensing, and
 - said projections are distributed in said dispensing range such that the recesses in said tablets complement each other at least on one side of said tablets to a figure composed of an angle and of a cross, respectively.
5. The dispensing device, as set forth in claim 1, which includes:
 - a shell having an open bottom and in inwardly extending flange formation at its top,

7

said shell surrounding said housing and axially slidable relative to the latter,
 said intermediate bottom having at least one lateral projection cooperating with said inwardly extending flange formation of said shell,
 said housing being open on one side, so that upon sliding axially said shell relative to said housing simultaneously lowering said intermediate bottom by means of said flange information and said lateral projection against said spring means and refilling said housing with a new pile of said tablets.

5

8

References Cited

UNITED STATES PATENTS

1,485,716	3/1924	Rogers	221—232
1,795,739	3/1931	Shield	194—4
2,477,034	7/1949	Avelli	221—232 X
2,620,061	12/1952	Uxa	221—229
2,620,250	12/1952	Pierson	221—232
2,748,979	6/1956	Szekely	221—229

10 STANLEY H. TOLLBERG, *Primary Examiner.*