

Feb. 7, 1967

M. K. TAYLOR ET AL

3,303,494

MAGNETICALLY OPERATED SIGNS

Filed Feb. 14, 1966

2 Sheets-Sheet 1

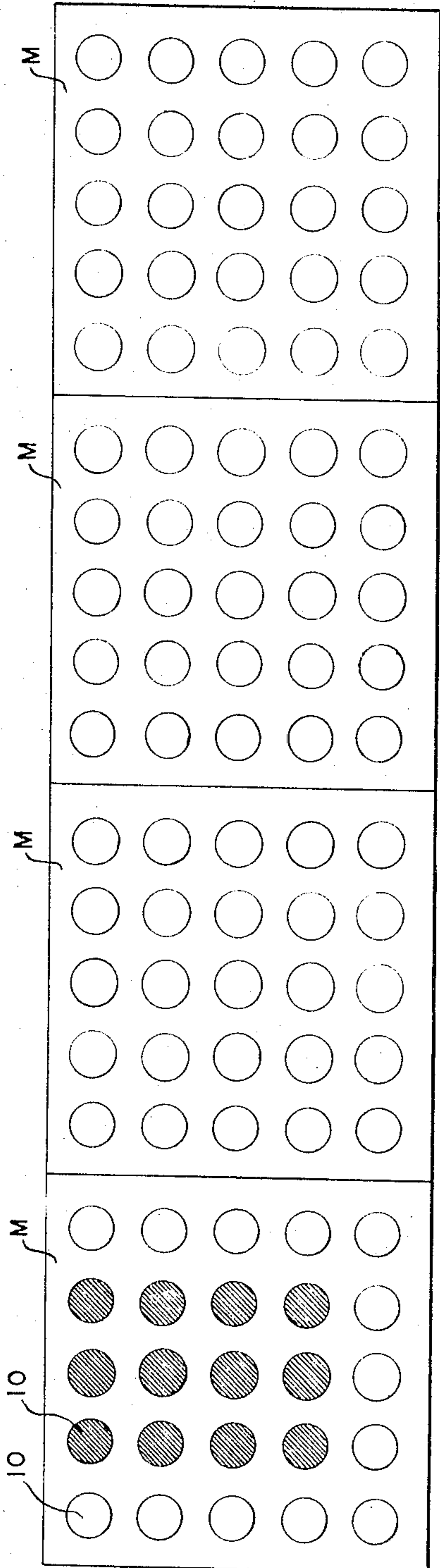

FIG. 1

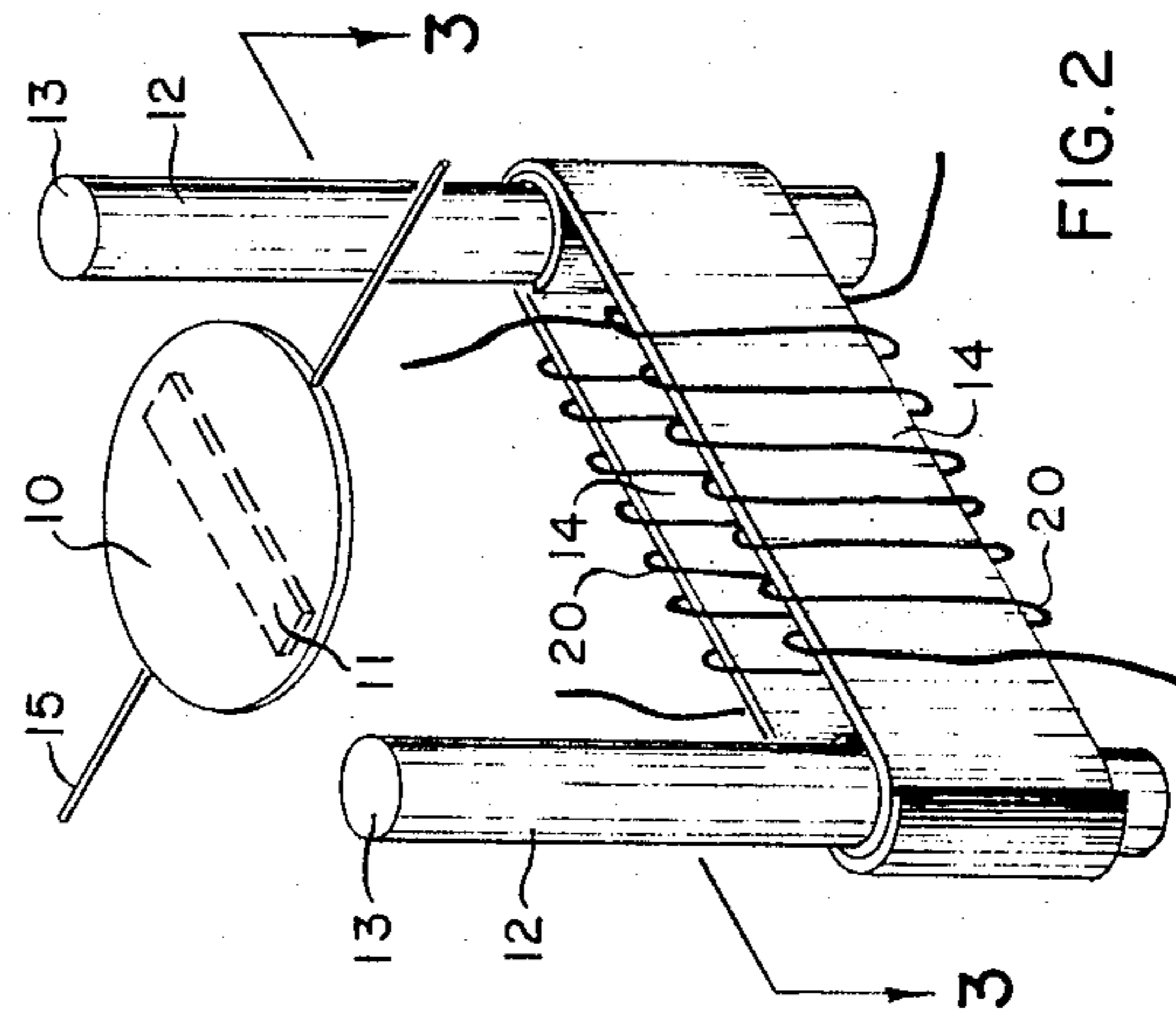

FIG. 2

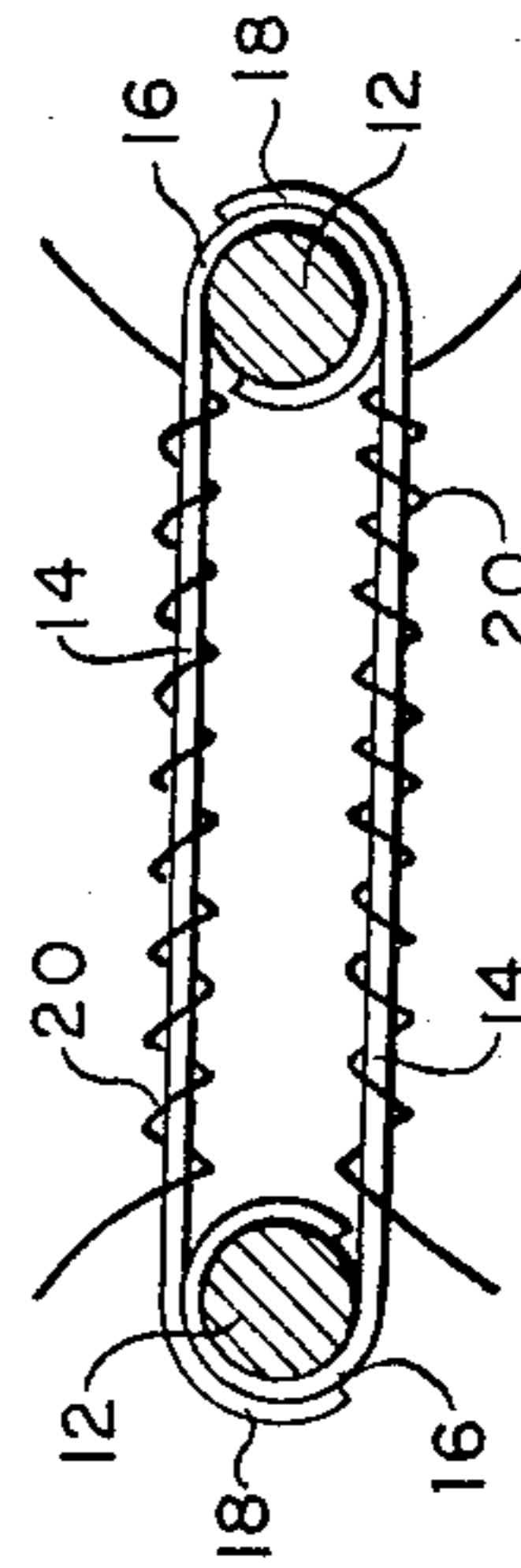

FIG. 3

BY *Fetherstonhaugh & Co.*
ATTORNEYS

Feb. 7, 1967

M. K. TAYLOR ET AL

3,303,494

MAGNETICALLY OPERATED SIGNS

Filed Feb. 14, 1966

2 Sheets-Sheet 2

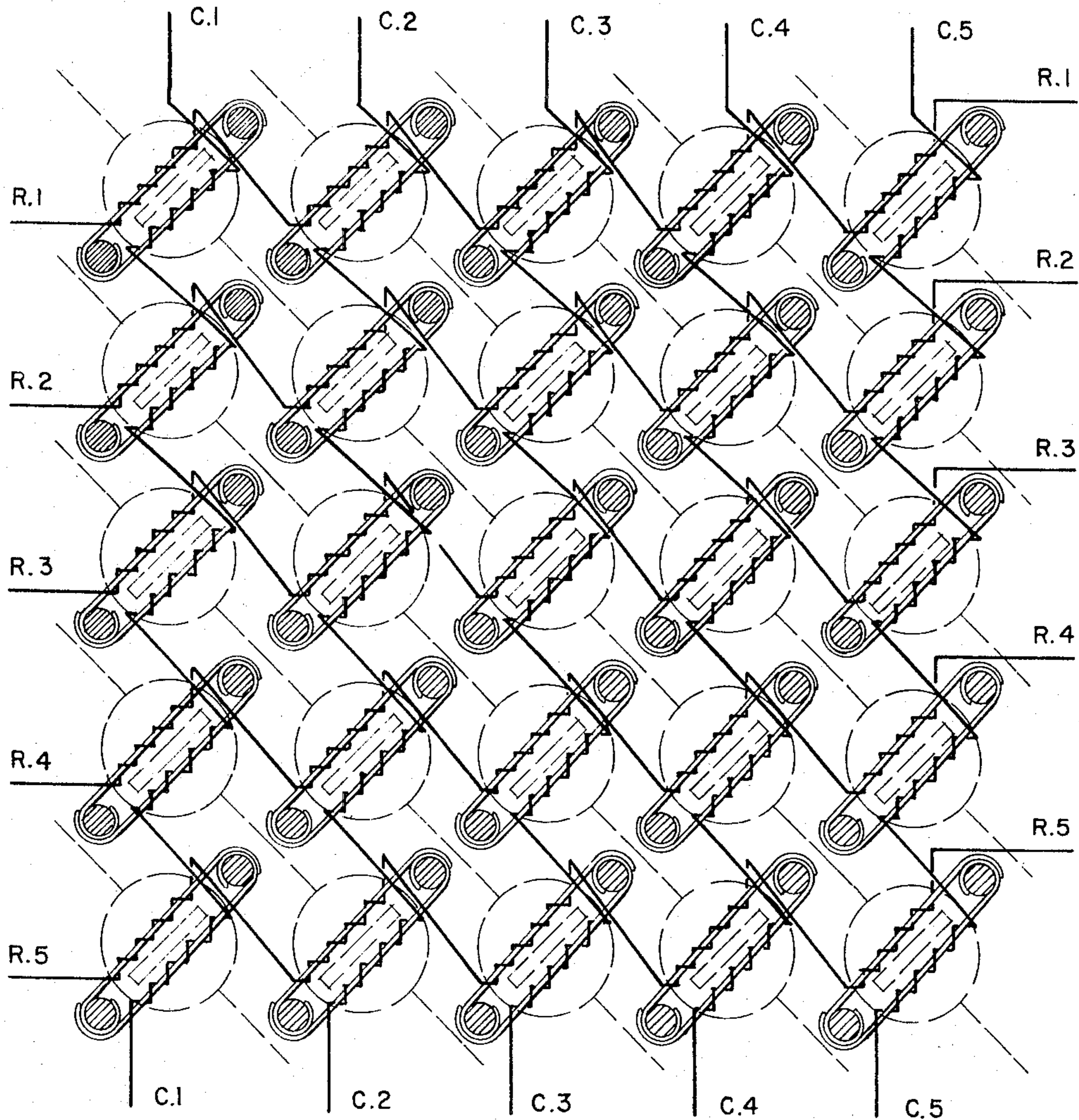

FIG. 4

BY *Fetherstonhaugh & Co.*
ATTORNEYS

1

3,303,494

MAGNETICALLY OPERATED SIGNS

Maurice Kenyon Taylor, Weston, Ontario, and Donald Winrow, Downsview, Ontario, Canada, assignors to Ferranti-Packard Electric Limited, Toronto, Ontario, Canada

Filed Feb. 14, 1966, Ser. No. 534,273
4 Claims. (Cl. 340-373)

This is a continuation-in-part of application Serial Number 342,057 filed February 3, 1964.

This invention relates to means and a method for selectively energizing a pair of magnet poles by electrical means for use in signs or in switching applications.

The term "saturation" where used herein means the property of a magnetic material whereby successive increments of magneto-motive force produce less and less magnetic flux in the material once a certain flux density has been reached. When a member is spoken of as being "saturated" it is meant that there are flux densities above such levels therein.

The method and means although they may have other applications, have been developed for use with a sign wherein the indicia on the sign are formed by the collective appearance of an array of magnetically actuatable elements which are differently coloured on different exposable surfaces. The device is thus primarily designed for use with a sign wherein the magnetically actuatable elements move as illustrated in United States application Serial No. 132,952, filed by Maurice K. Taylor on August 21, 1961, now Patent Number 3,140,553, although it will be realized that the method of creating magnetic poles described herein is intended to replace the arrangement shown in the application referred to above, and further it will be realized that this development is not necessarily limited for use with signs of this type.

The method is felt also to have value when used to perform electric switching functions through the use of movement of magnetically actuatable elements.

A method of winding for properly energizing magnetic pole pieces is shown in the above co-pending application, and in that case the magnetic pole forming elements are U-shaped and are provided with a winding (the winding being represented by a wire through the bight of the U-shaped element) corresponding to each indicia to be formed by that portion of the array containing the element. It will be understood that the array is usually of rectangular form and is divided into rectangular sub-arrays in each of which one or more indicia characters will be formed. Such sub-arrays, whether array or sub-array are rectangular, are referred to herein as "modules," although the term "module" herein includes an entire array or sign where the whole array or sign is designed to portray a single character or picture, and the term is also applicable to signs made of an array of elements where the modules move across the array, portraying correspondingly movable characters, as in a moving news sign. With the provision of independent wiring for each character in each module, as shown in the prior application, it is necessary that for a module there be thirty-six wires to portray the twenty-six letters and ten numbers. It has been necessary, with this prior design in order to avoid "sneak" current paths, to provide a diode, relay contacts or switch contact for each of said circuits and thus the complexity and expense of the wiring and circuit elements has been considerable.

The present invention allows for considerable simplification of the wiring by providing a method for creation of the pole pieces and a design of the pole piece forming elements, which allows for simple wiring of the array. For example, in the case of a five by five foot module, that is, where there are five rows of five elements, thirty-

2

six wires would be required in the system of application Serial No. 132,952, while ten wires (corresponding to the sum of the number of rows plus the sum of the number of columns) are required with the present arrangement.

The invention provides a pair of pole forming members, each having free pole forming ends, and these are joined by at least two flux-permeable members, each providing a separate flux path between the pole forming members. The term "flux-permeable" as used herein being subject to the qualification that such members are, in accord with the teaching herein, sometimes in saturated condition. Each flux-permeable member has an energizing winding associated therewith, and the design of the flux-permeable member is such that all the windings associated with a pair of pole forming members must be energized before the corresponding pole forming members are sufficiently energized to actuate the corresponding indicia forming element. The windings for the flux-permeable members are connected in a number of circuits. The windings are in most conceivable applications so connected in the circuits that the combination of circuits which energizes all the flux paths of any particular pole piece is unique in a module. Thus, considering pole pieces with only two flux-permeable members joining them, it requires simultaneous energization of both windings to energize the pole piece and materials to operate the magnetically actuatable member as hereinafter discussed.

In the discussion to follow where a flux-permeable is spoken of as being "energized" it should be realized that it is meant that current has been caused to flow in the associated winding causing it to be energized thereby generating flux in the flux-permeable member. Conversely when a winding is energized by current passing therethrough, the flux-permeable member is spoken of as being energized due to the consequent flux generated therein.

Moreover the windings, the energization, and the flux-permeable members are designed so that, when energized, the flux-permeable members will be saturated to a certain degree when less than all such flux-permeable members are simultaneously energized, but so that such flux-permeable members will be less saturated or unsaturated when all flux-permeable members are simultaneously energized with mutually opposing polarities.

By "opposing polarity" is meant that pairs of flux-permeable members, when considered in a series circuit will under the conditions have opposing polarities.

It is found that under these conditions, when one or more of the flux-permeable members are energized, and one or more of the flux-permeable members are de-energized, then the reduction in flux at the pole forming members compared with such flux when all such flux-permeable members are energized under mutually opposing polarities is much greater than would be expected from an analysis of the magnetic circuits assuming non-saturated conditions at all times. For example, if two flux-permeable members only are used and these are so operated that with opposed polarities they are either near but below saturation or just above saturation; then saturation or greater saturation, respectively, will exist with the same conditions of energization of the coil of one only of such flux-permeable members, and the flux between the pole forming members with one flux-permeable member energized will be much less than half the flux than when both members are energized with opposing polarities.

Because of this mode of operation, the stability of the magnetically actuatable members in a desired orientation is increased, since such orientation acquired due to the simultaneous energization of all the flux-permeable members with mutually opposing polarities, cannot, with suitable design, be destroyed by the later energization

of less than the full number of flux-permeable members with the opposite polarities. The stability is such, with suitable design, that the desired orientation of a member accidentally (by such as wind or impact) deflected to its opposite orientation will be regained. Under the aforesaid conditions with proper selection of the pole piece material the coercivity of the pole pieces, acquired by simultaneous mutually opposed energization of all the flux-permeable members under non-saturated or slightly saturated conditions thereof, is sufficient to withstand the combined effects of the induced magnetism in the pole pieces due to the magnet on the magnetically actuable member and the magnetism due to the energization of less than all the flux-permeable members in the opposite polarity.

In a preferred form of the invention a number of circuits are provided, corresponding to the number of rows in a module, with each circuit incorporating one winding from each of the pairs of windings associated with elements forming the corresponding row in the module, and circuits are also provided corresponding to the respective columns, each circuit containing the other of the windings associated with elements in such column, and thus, referring to the circuits as characteristic of a row or a column, each pair of pole pieces corresponding to an element position in the module is uniquely energizable by a combination of one circuit corresponding to its row and another corresponding to its column, in the module.

Preferably the flux-permeable members are formed of silicon iron, being a material of high permeability and requiring a relatively lesser amount of material to ensure that sufficient flux-carrying capacity is provided. Such flux carrying capacity and the dimensions are such that the flux-permeable members may be operated in a saturated state while less than all are energized but in a less saturated or an unsaturated state where all are developing mutually opposing fluxes. The ratio of interpole piece flux between all and a lesser number of mutually opposing flux-permeable members, has been found to be improved (i.e., increased) if, when silicon iron flux-permeable members are used, they are annealed prior to winding.

Preferably where two flux-permeable members are used to connect pairs of pole forming members, the flux-permeable members are each swingably mounted and magnetically connected to one of the pole forming members and adapted to clip on to the other pole forming member or to the swingable mounting for the converse clip.

In drawings which illustrate a preferred embodiment of the invention:

FIGURE 1 is a schematic view of an array divided into sub-arrays;

FIGURE 2 is a view of one of the elements in the array and the inventive design for actuating it;

FIGURE 3 is a view along the line 3—3 of the pole piece assembly as illustrated in FIGURE 2; and

FIGURE 4 is a view illustrating the wiring of a module of the array.

In the drawings, FIGURE 1 illustrates an array five elements deep by twenty wide, each element, as shown in FIGURE 2, comprising a swingably and preferably rotatably mounted magnetically actuable element 10, carrying a permanent magnet 11 with the polar magnetic axis transverse to the axis of the mounting filament 15. The element 10 is designed to display a white or a black surface on opposed sides. The array is divided into four modules M, each being a rectangular sub-array comprising rows of five elements each, whereby four indicia may be displayed by the array.

In FIGURE 2 is shown the construction of the pole piece assembly associated with each of the elements 10, and the pole piece assembly comprises a pair of pole pieces or rods 12 of permanently magnetizable material, preferably hardened carbon steel. Each such pair of rods 12 are mounted for correct relationship to control the orientation of one of the elements in the array, each

pair being located to control one element, and would be mounted in a plastic or other mounting member, not shown.

The orientation of the elements is gained by changing the polarity of the rods 12 to set up oppositely directed magnetic fields between the rods with which the magnet will align as closely as its freedom of mechanical movement will allow it. In other words, the poles of the permanent magnet will be attracted to the oppositely polarized rods and when the polarization of the rods is changed, a rotational torque will be applied to the element 10 to cause its change of orientation. Flux-permeable connecting members 14 provide at least two, and preferably two, magnetic paths between a pair of rods 12, and such connection members are preferably arrayed together to form, with the two rods 12, a rectangular U-shaped electromagnet, with the connecting members 14 forming the base of the U remote from the indicia forming elements; and the free ends 13 of rods 12 of the pole forming members being adapted to form magnetic poles to actuate the indicia forming element in accord with the polarity of the poles.

Preferably the two flux-permeable members 14 are formed in the shape of an extended numeral 6, with the substantially closed spiral 16 of the 6 being of a shape to be received slidably on one of the rods and with the open end 18 of the 6 being shaped to clip onto the convex outer portion of the substantially closed spiral 16 of the other member 14, whereby each member 14 slidably and swingably mounted on one rod 12 will clip onto the outer surface of the open convexity 18 of the other member 14 at the other rod 12 and form together a U-shaped electromagnet with the cross bar of the U being formed by the two flux-permeable members 14, which, it will be noted, form separate flux paths. A winding 20 is formed on each of the flux-permeable members 14.

Preferably, the flux-permeable member 14, is of high flux-permeability, and such member 14 is necessarily formed of annealed silicon iron having a high permeability and thus requiring less material to form a member which does not saturate or is just saturated under simultaneous, mutually opposing energization of connecting members 14 (although the design is such that such connecting members will be saturated, or saturated to a greater degree, respectively, under the same ampere-turn conditions where one member 14 is energized and one is not).

It will be seen, from the description to follow that each of the windings 14 is connected in a circuit, usually containing other windings and that the combination of circuits for a pair or plurality of windings associated with an element position will in almost all conceivable applications of the device, be unique for each element position in a module.

The design operation of an individual pole piece will now be discussed. The design of the source or sources (not shown) for energizing the windings; the windings themselves; and the members 14; are chosen so that: if one winding 20 only is energized, the permeable member 14 whose winding is energized will be saturated, resulting in a reduction in flux, compared to that available with the same winding energization under non-saturated or less saturated conditions. As a result, the flux appearing at the free ends 13 of the pole forming members, with one winding only energized under saturation conditions in the flux-permeable member, is much less than one-half that which is produced when the two flux-permeable members are simultaneously energized in opposition. The flux produced with only one flux-permeable member energized can be by correct design and operation, made one-fourth or one-fifth the flux with two mutually opposing flux-permeable members. The lower this ratio is, the better, since the result is to increase the ability of the coercivity produced in the pole pieces by the two simultaneously energized mutually opposing flux-permeable members, to oppose the subsequent positioning of the magnetically ac-

5

tuable member in an undesired orientation due to either.

(a) the momentary rotation to such undesired orientation (due to air currents, shock or impact) with the consequent inductive effect by the magnet of the magnetically actuatable member; upon the magnetic state of the pole forming members;

(b) the effects on the pole forming members of one or more energizations of one only of the flux-permeable members at a time, in a polarity opposing the desired polarity in the pole forming members; or

(c) a combination of the above effects.

It may be possible to obtain ratios of as low as one-tenth or better by careful selection of materials from those which, in toroidal form, would give a substantially square B-H curve.

It will be noted that even with such materials, the effects would be modified in use, so that no matter how square the B-H curve for the material in toroidal form, the B-H curve of the flux-permeable material must be considered as a rounder modification of the toroidal curve, due to the air gaps inherent in the magnetic circuitry devices in accord with the invention.

Thus, while energization of one only of the flux-permeable member windings, will not rotate the magnetically actuatable member, energization of both, simultaneously, with opposed polarities will cause the magnetically actuatable member, if not already in the desired orientation, to be rotated to such desired orientation.

Thus, it will be seen, that when operating conditions and materials are chosen as taught herein, a pole piece assembly cannot actuate an element unless both windings are simultaneously energized. The rods 12 are, however, made of material which will retain magnetization once applied, and hence the simultaneous mutually opposing energization need only encompass a very short interval.

In FIGURE 4 is shown the arrangement of a module formed with five rows (or five columns), each with five elements in a row or column, and it will be seen that preferably, with the rectangular construction, a circuit C1 to C5 is provided containing one winding from each of the pairs of windings associated with the elements forming a column in the module, and a circuit R1 to R5 is provided containing the other winding from each of the pairs of windings associated with the elements forming a row in the module; thus the two windings associated in a pair comprise one from a column circuit and one from a row circuit and the combination of circuits to energize a pair of rods 12 in an element position of the module is unique for any element position in the module.

In operation, assuming that in the left-hand module shown, it is desired to portray a U, then it will be understood that it will be desirable to have the two outer columns and the bottom row of magnetizable elements portray one colour and the remaining elements portraying the other colour. The permanently magnetizable rods 12 shown will, because of their design coercivity discussed earlier, retain a given polarity until a new polarity is provided, and thus it is not necessary to provide continual energization for the pole pieces (through the windings) and thus the only time it is necessary to provide energization is when the polarity of a pole forming member is to be changed. Initially it does not matter what is the arrangement of contrasting surfaces in the left-hand module, and it will be assumed that the U is to be portrayed by light and dark elements as shown in FIGURE 1 in the left-hand module. To portray the U, therefore, it will be necessary to energize the windings to obtain the element arrangement desired.

Due to the arrangement of the circuitry, it will be noted that all the elements forming the U cannot be switched simultaneously, since this would require the energization of all the row and column circuits, which would switch unwanted elements. Also it will be noted that the

6

switching to obtain dark and light elements may not be achieved in the same row or column at the same time, since opposite polarities would be required of the same winding. It is possible to sequentially energize one (desired) element position at a time by providing simultaneous energization of the two windings associated with an element, the two windings associated with the next element it is desired to switch, and so on, or, in the circuitry arrangement shown, to energize one column circuit at a time, simultaneously with those row circuits where it is desired to switch elements corresponding to the column selected. In this way the switching to achieve correct orientation of the elements forming the U may be provided with the number of sequential steps corresponding to the number of columns, followed by similar sequential steps to secure the required orientation of the elements forming the interstices of the letters. With a rectangular module, the selection of rows and columns in the above example may be interchanged. The sequential operation may be achieved in any one of a number of well known ways and is not here discussed, since such alternatives are well known to those skilled in the art.

It will be obvious that if the sense of the windings in relation to the polarity of the energization is incorrect, then the two windings, when simultaneously energized, will tend to oppositely polarize the pole pieces and no result will be obtained.

Assuming in the example given, to indicate the outline of the U, the pole pieces are to be sequentially energized in rows, then taking the first row, one winding of each of the pairs in the row will be energized by energizing circuit R1 simultaneously with the column circuits C1 and C5, corresponding to the first and fifth columns both in a polarity to get these elements to display the lighter contrasting colour. No sufficient polarity will appear at the poles of the pole pieces of the three middle columns to move the magnetically actuatable member, since the saturation effects discussed previously will reduce the flux at the pole pieces resulting from such energization below that necessary to overcome the coercivity of the pole pieces and rotate the member. On the other hand, in the two outside column positions in the row both windings will be energized in mutual opposition and due to the resulting magnitude of the flux at these positions, the corresponding elements 10 will be rotated to show the lighter contrasting colour. Then the next row of elements may be selectively switched in a similar manner and so on. When the elements forming the outline of the U have been correctly energized, including all the elements in the lower row, then the same system is followed in providing a contrasting appearance for the elements forming the interstices of the U.

It will be obvious that if the sense of the windings in relation to the polarity of the energization circuits is incorrect, then two windings simultaneously energized will tend to oppositely polarize the pole pieces and no result will be obtained, and thus proper design and winding procedures must be applied to the circuitry, the winding and the energization of the permeable members.

It will also be obvious that in each module, the combination of circuits must be unique for each pair of pole pieces. It will be obvious also that, if desired, three or more independent flux-permeable paths might be provided between pairs of rods 12, each one with a winding and each position in the array having a unique combination of circuits for the windings.

The construction of the individual pole piece assemblies using two flux-permeable paths comprises forming each flux-permeable member 14 in the shape of an elongated 6, as described, with the closed or substantially closed arc 16 of the 6 designed to be slidably and swingably received about the pole piece rod 12 and with the concave side of the open arc 18 of the 6 arranged to clip over the outer convex surface of the other arc 16; thus the two flux-permeable members may be slid over the

respective pole pieces already held in place in a mounting and each clipped over the substantially closed spiral of the opposite member—a simple and inexpensive design.

The invention has been described for use with magnetically actuatable elements whose purpose is to provide alternately displayed contrastingly coloured sides. This is indeed, at the present, its most common application. The innovations of the invention may also be used where the purpose of altering the orientation of a magnetically actuatable element is to open and/or close an electrical circuit or circuits where the magnetically actuatable element mounts the moving contact or contacts of a switch.

Such switching action could be combined with the operation described in the preferred embodiment so that the device simultaneously: provides a change in the colour displayed; and performs a switching function.

We claim:

- 1. A sign for displaying indicia, comprising:
 - an array of magnetically actuatable indicia forming elements defining a viewing direction;
 - each of said elements having a swingably mounted member;
 - having two surfaces of contrasting appearance;
 - and carrying a permanent magnet with poles extending transversely to the axis of rotation of the member;
 - a magnetic field producing means for causing movement of said member:
 - including a pair of permanently magnetizable pole forming members;
 - a pair of flux-permeable members joining each pair of said pole forming members in separate magnetic paths;
 - an electrically conducting winding associated with each

of said flux-permeable members arranged and constructed to create, when electric current is flowing therein, magnetic flux in the flux-permeable member with which it is associated;

to polarize said pole forming members in one or another polarity;

said pole forming members when sufficiently magnetized by such flux being effective to rotate said magnetically actuatable member between two positions determined by said respective polarities;

said contrasting surfaces being arranged so that one is displayed in the viewing direction in each of said positions.

2. A device as claimed in claim 1 wherein said flux-permeable members are made of annealed silicon iron.

3. A device as claimed in claim 1 wherein said pole forming members are rod-like, the said flux-permeable members are each shaped to be swingably mounted on one rod and to detachably attach to the other rod.

4. A device as claimed in claim 3 wherein the end of each flux-permeable member remote from its swingable mounting is shaped and designed to resiliently clip onto the other flux-permeable member adjacent said swingable mounting.

References Cited by the Examiner

UNITED STATES PATENTS

2,959,219	11/1960	Hajny	317—188 X
3,042,823	7/1962	Willard	340—166 X
3,140,553	7/1964	Taylor	340—373 X

NEIL C. READ, *Primary Examiner.*

I. J. LEVIN, *Assistant Examiner.*