

Jan. 4, 1966

K. C. ALLISON

3,226,999

INDEXING-DETENT MECHANISM

Original Filed Dec. 2, 1960

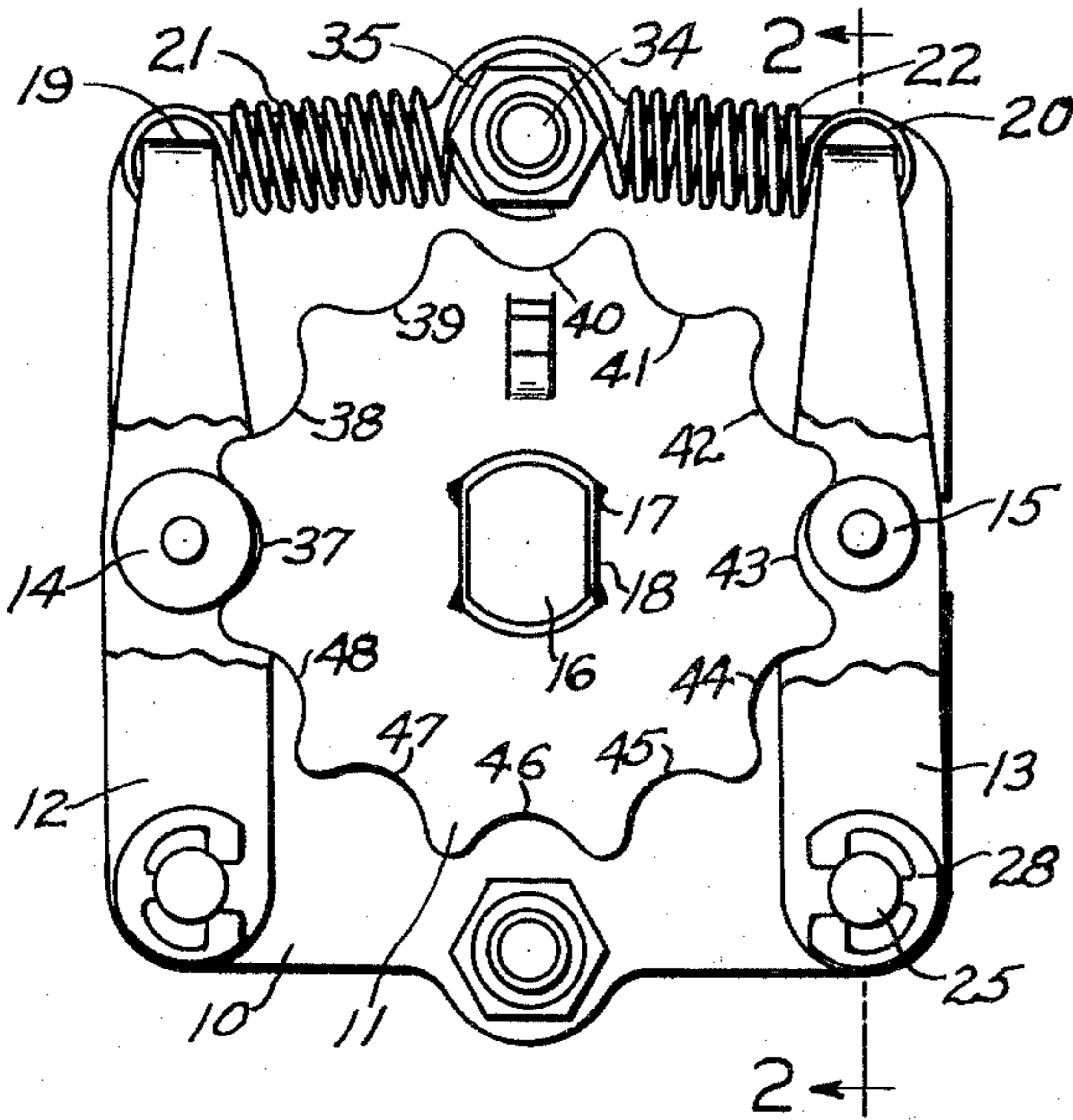

FIG. 1.

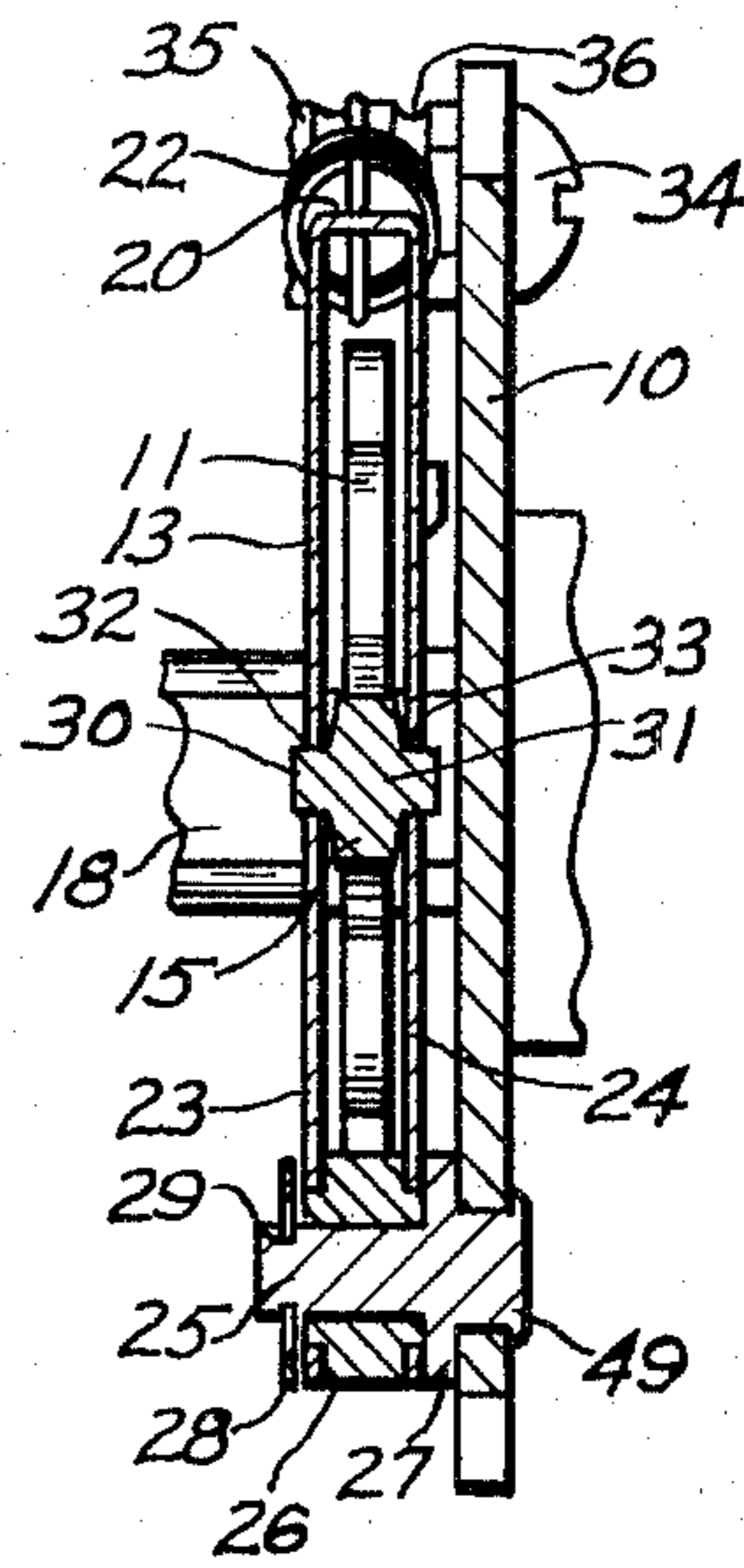

FIG. 2.

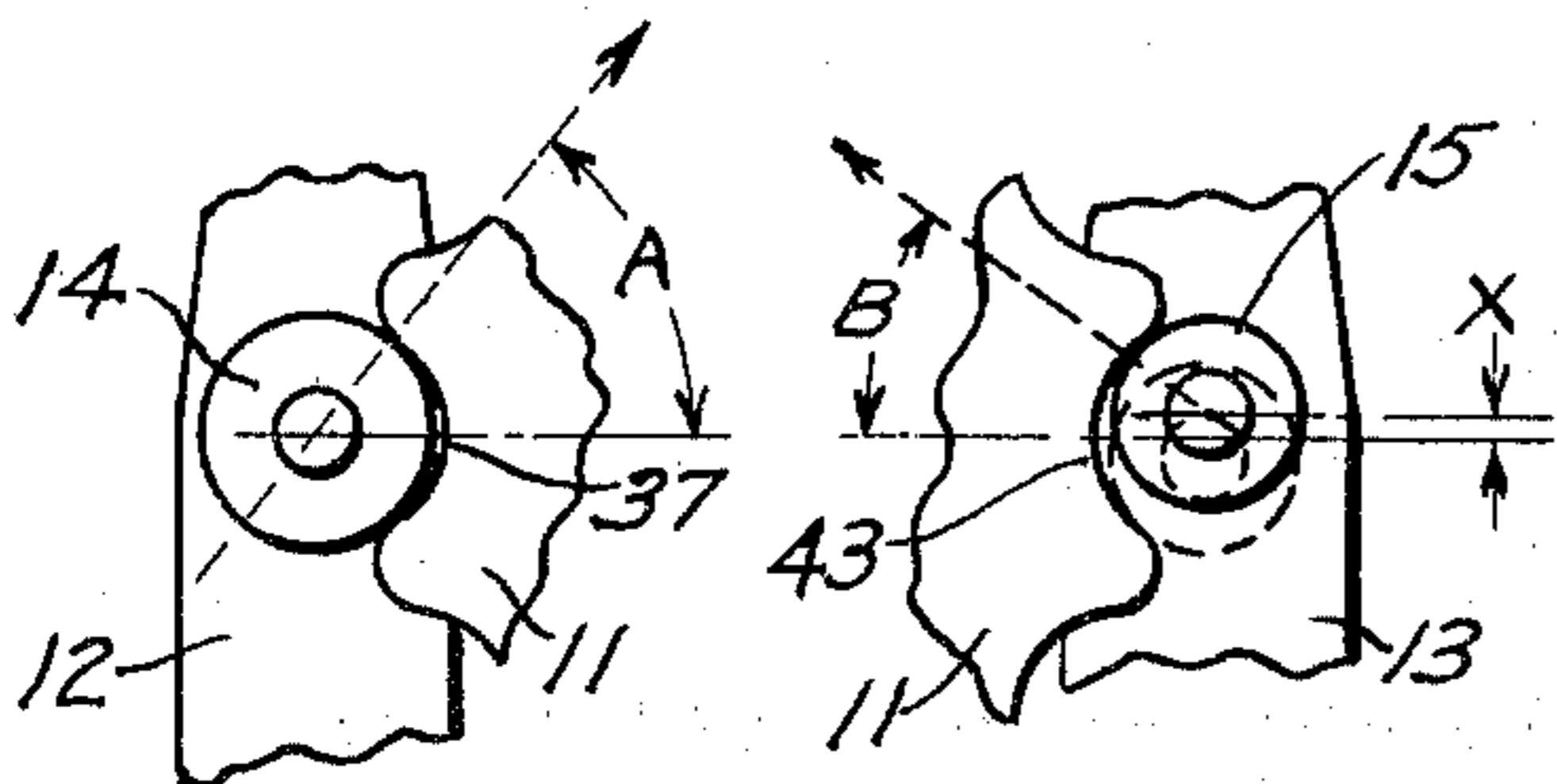

FIG. 3.

FIG. 4.

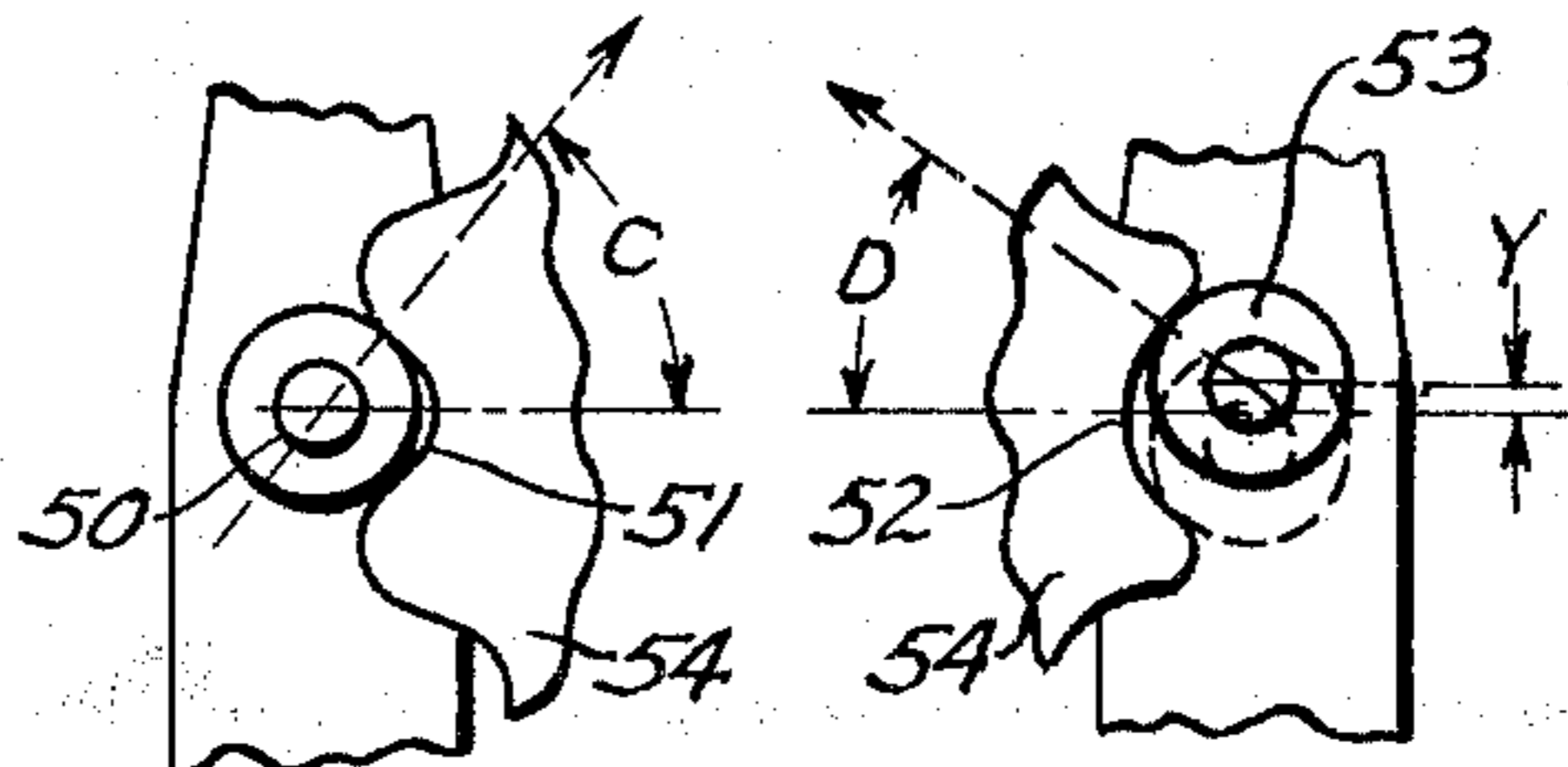

FIG. 5.

FIG. 6.

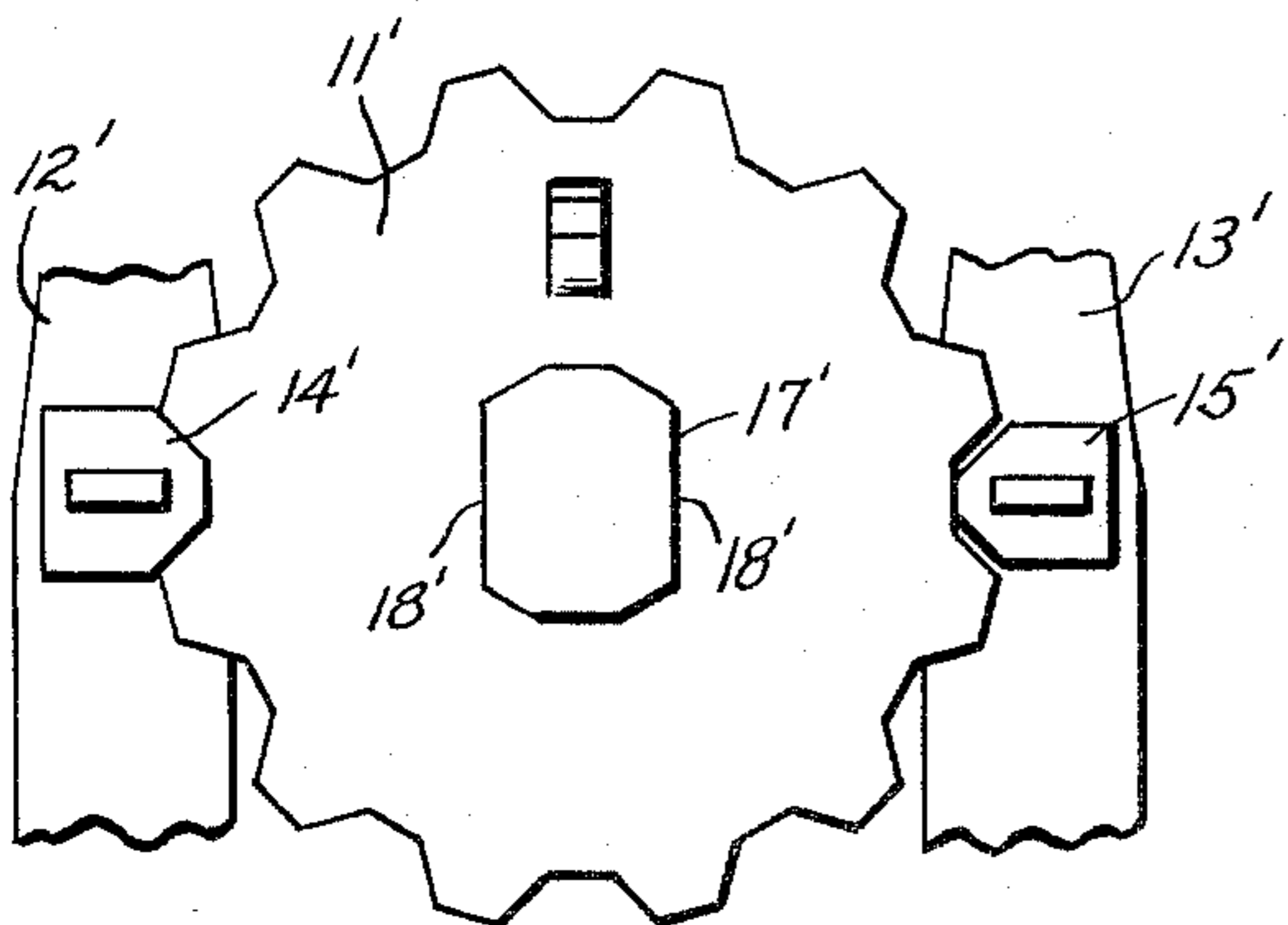

FIG. 7.

INVENTOR.
KENNETH C. ALLISON

BY

Jennings B. Hampson
ATTORNEY.

1

3,226,999

INDEXING-DETENT MECHANISM

Kenneth C. Allison, Crystal Lake, Ill., assignor to CTS Corporation, Elkhart, Ind., a corporation of Indiana
Continuation of abandoned application Ser. No. 73,422, Dec. 2, 1960. This application Jan. 28, 1963, Ser. No. 255,151

10 Claims. (Cl. 74—527)

This is a continuation of my application filed December 2, 1960, Serial No. 73,422, entitled "Indexing Means for Rotary Switches," now abandoned.

The present invention relates to rotary switches and, more particularly, to an indexing-detent mechanism for positioning the shaft of a rotary electrical switch.

Indexing-detent means of the general type disclosed herein are notoriously old. That is, most all indexing means use a resiliently biased detent for engaging one of the indentations or cavities provided on an indexing plate. By exerting sufficient force, the resilient means holding the detent in the indentation is overcome, and the detent moves outwardly allowing another indentation to move into position to be engaged by the detent. Other variations are known but this principle is employed in the great majority of indexing mechanisms.

One general requirement for all indexing means is that they must be economically made. This is particularly true of indexing mechanisms used with rotary electrical switches which are manufactured in large quantities and sold in a very competitive market. The mass production techniques applied to the manufacture of the mechanisms make it necessary that certain tolerances are introduced into the dimensions of the parts.

As a result of the dimensional variations caused by the tolerances imposed on the parts, a problem commonly referred to as the "double index feel" occurs, i.e., when two or more detents are unable to be seated in their respective indentations simultaneously. As a result of the dimensional variations always present in the parts making up the indexing mechanism, there will usually be at least one position where the "double index feel" will occur. In this position, only one detent will be able to seat properly in its indentation while the other one or more detents will be riding the side of one of the indentations, partially in and partially out. When this condition occurs, the operator of the switch must choose which one of the detents he wants to be seated, which results in his choosing between the two or more positions available. Actually, he may not be conscious of choosing anything but will simply stop at the first position available. This results in different positions for the switch depending upon which direction the switch is being rotated. If the error is slight, no damage will result. However, if the adjustment is critical or the error is large, the result may damage the switch or result in an open circuit due to the improper position of a contact.

The common solution to this problem is to use only one detent. However, this solution introduces other problems which partially offset the advantages gained. First, the use of only one detent imposes a side thrust on the operating shaft of the switch which causes misalignment of the shaft in its bearing. Such action generally increases the torque required to operate the switch and results in rapid wear of the bearing.

Second, the use of only one detent results in the loss of "pull-in" power and length. "Pull-in" power is the ability of the indexing mechanism to snap into position once the detents start into the indentations. Obviously, two detents would have twice the "pull-in" power of one detent. "Pull-in" length is increased by using multiple detents since the resulting increase in "pull-in"

2

power results in the detents being able to move more rapidly into position on their own initiative from a greater angle of displacement.

Accordingly, it is an object of the present invention to eliminate the problem of "double index feel" and yet retain all of the advantages of using a multiple detent indexing mechanism.

An additional object of the invention is to provide an indexing mechanism employing two or more detents which relies on only one detent to determine the final position of the unit.

Further objects and advantages of the present invention will become apparent as the following description proceeds, and the features of novelty which characterize the invention will be pointed out with particularity in the claims annexed to and forming a part of this specification.

Briefly, the present invention provides an indexing mechanism equipped with multiple detents but with only one detent large enough to contact simultaneously both sides of the indentation or cavity engaged thereby. This simple expedient results in an indexing mechanism having one detent always in control for positioning the switch but yet retaining the balancing effect of the other detent. The smaller detent, being of such a size that it cannot contact both sides of the indentation engaged thereby, cannot vie with the larger detent for control. In the alternative, the detents may be of the same size and the indentations of different sizes. This results in an elimination of the problem of "double index feel."

The invention will now be described in detail in conjunction with the attached drawings in which:

FIGURE 1 is a plan view of the indexing means embodying the invention with portions of the arms broken away to show the detents in engagement with the indentations on the index plate;

FIGURE 2 is a sectional view taken along line 2—2 of FIGURE 1 showing a preferred construction of the arms and the method of pivotally mounting the detents therein, assuming that FIGURE 1 is shown in full;

FIGURE 3 is a fragmentary view of the large detent engaging one of the indentations shown in FIGURE 1;

FIGURE 4 is a fragmentary view of the smaller detent engaging one of the indentations shown in FIGURE 1;

FIGURES 5 and 6 are fragmentary views of another embodiment of the invention wherein the detents are of the same diameter and the indentations are of a different diameter to produce the same result as in a preferred form of the invention; and

FIGURE 7 shows still another embodiment of the invention as applied to non-circular detents and indentations.

The index mechanism as illustrated in FIGURE 1 of the drawings employs two detents arranged on opposite sides of a shaft. Any number of detents may be used; however, the detents generally are arranged symmetrically so as to eliminate side thrust on the shaft.

The indexing mechanism comprises a mounting plate 10, an indexing plate 11 and a pair of arms 12 and 13 which supports detents 14 and 15. The indexing plate 11 is supported by a rotatable shaft 16, and rotation is imparted to the plate 11 by provision of a flat-sided opening 17 engaged by the milled flats 18 provided on the shaft 16.

It is not necessary that the shaft 16 extend through the mounting plate 10 and, if it does, it need not support it. Some means are necessary, however, to insure that the mounting plate and indexing plate remain in parallel and adjacent relationship.

The arms 12 and 13 are pivotally mounted on the mounting plate 10 so as to lie in the same plane as

the indexing plate 11. The arms are U-shaped and are formed from a thin metal strip. The bights 19 and 20 of the arms 12 and 13 respectively provide a convenient place for connecting the ends of the springs 21 and 22, the connection being at a maximum distance from the pivot point of the arms thus resulting in the most efficient use of the spring force. The other ends of the springs 21 and 22 are hooked over the bolt 34 and held in place by the nut 35 and the washers 36.

The construction and manner of assembling the arms and detents to the mounting plate are best shown in FIGURE 2. Extending through the two sides 23 and 24 of the arm 13 at the end opposite from the bight portion is a pin 25. The pin 25 also extends through a spacer 26 and the mounting plate 10. The pin 25 is provided with a radial flange 27 for engaging one side of the mounting plate 10. One end 49 of the pin is upset against the side of the mounting plate to mount securely the pin and the arm to the mounting plate. The flange 27 also serves to space the arm the desired distance from the mounting plate. A snap ring 28 is installed into the groove 29 provided in the other end of the pin to insure that the arm remains in position on the pin.

The spacer 26 holds the sides 23 and 24 of the arm 13 in predetermined spaced relationship. The distance between the sides corresponds to the thickness of the detent 15 and insures that the sides are maintained in proper position to support rotatably the extensions 30 and 31 of the detent. As shown, the extensions 30 and 31 journalled in apertures 32 and 33 respectively are an integral part of the detent.

The arms are spaced from the mounting plate a distance necessary to bring the detents 14 and 15 into engagement with the periphery of the indexing plate 11. The diameter of the indexing plate and the length of the springs 21 and 22 are arranged so that the springs are always extended when the detents are in this position, thus insuring that the detents will be positively held in engagement with the periphery of the indexing plate at all times.

The periphery of the indexing wheel 11 is provided with a plurality of indentations, e.g., scallops, or undulations. That is, the wheel 11 has a series of equally spaced circular segments removed from its edge to provide indentations 37 through 43 to receive the detents 14 and 15. In the preferred form of the invention shown in FIGURES 1 through 4, the indentations are all identical in shape and size. The detents 14 and 15, however, are not of the same size.

As illustrated in FIGURE 3, the size of the detent 14 is so arranged with regard to the indentation 37 that it cannot completely enter the indentation. It engages the side walls of the indentation at a point well above the bottom of the indentation. The detent 15, however, as shown in FIGURE 4, is of such a size that it will easily enter the indentation 43 and, normally, engage the bottom of the indentation. In any event, the detent 15 engages the indentation at only one point.

To illustrate better the invention, the detent 15 is shown in FIGURE 4 to be displaced from the center of the indentation 43 by the distance x . Such a condition can easily occur due to accumulated manufacturing tolerances, and usually does at least at one position on the indexing mechanism. This causes the "double index feel" described above. In this position, if the two detents 14 and 15 were the same size, two positions would be available to the operator; one with the detent 14 seated in its indentation 37 and another with the detent 15 seated in its indentation 43. Either position would feel the same to the operator and, therefore, to his knowledge, either position could be the correct one.

By simply enlarging one detent, this condition is eliminated. With the detents in the positions shown, there will be only one position available to the operator and

he will not be conscious of the fact that one of the detents is improperly seated in the indentation.

The detent 14 will always control the indexing mechanism because of the mechanical advantage it has over the other detent. As shown in the drawings, the center of each detent is equidistant from the center of the indexing plate. Since the springs 21 and 22 are of equal strength, each detent is exerting the same force against the indexing plate. The angle at which these forces are being exerted, however, is different.

Assume, for example, that the indexing plate has been rotated to the position where, due to cumulative manufacturing tolerances, the detent 15 is out of alignment by the distance x . A component of the force exerted against the indexing plate tends to rotate the indexing plate in a counterclockwise direction as viewed in FIGURES 1 and 4 of the drawings. The magnitude of this component depends on the size of the angle B . Resisting this force will be a component of the force exerted by the detent 14 against the indexing plate. The magnitude of this component depends on the size of the angle A . This is based upon the assumption that motion is impending and all of the force exerted by the detent 14 is in the direction necessary to resist its being displaced further outwardly.

Since the angle A is greater than the angle B , the component of the force exerted by the detent 14 is greater than the component of the force exerted by the detent 15. The detent 15, then, cannot displace the detent 14. Should the operator rotate the indexing plate until the detent 15 is seated in its indentation, the detent 14 will control. At the moment the operator releases the shaft, the detent 14 will displace the detent 15 to the position shown and seat itself in its indentation. This will occur for the same reasons as explained above, plus the fact that when the detent 14 is displaced by the distance x , it will be moved outwardly a much greater distance than would be the detent 15, and it would be exerting a greater force on the indexing plate since the spring 21 would be further extended.

Another embodiment accomplishing the same result is illustrated in FIGURES 5 and 6. Here, instead of providing different sized detents, different sized indentations are used. This can be accomplished by having all the indentations on one side of the indexing wheel of the larger size or by having every other indentation of the larger size. There must always be a small indentation diametrically opposite each large size indentation regardless of how they are arranged on the indexing plate.

The principles of the mechanism remain the same. At the moment of impending motion, the force exerted by the detent 53, displaced a distance y , is the same as the force exerted by the detent 50, the detents being equidistant from the center of the indexing plate in this position. Here again, the angle at which the force is exerted determines which detent will control. Obviously, the angle C is greater than the angle D , giving the force exerted by the detent 50 the mechanical advantage and allowing it to control the position of the indexing mechanism. It is also to be understood that the detents 50 and 53 may be polygonal and correspond to suitable indentations provided on the indexing mechanism.

Regardless of the configuration of the detents and the indentations, the detents and the indentations are so arranged and constructed that the contact portion of the indentation engaged by one of the detent members is less than the engaging portion of the detent member engaged therewith and that the contact portion of the indentation engaged by the other of the detent members is greater than the engaging portion of the other of the detent members.

The detent 14 need not be so large that it cannot reach the bottom of the indentation for the mechanism to operate properly. If it is approximately the same size as the

indentation whereas the other detent is smaller, the same result can be obtained. This would be the arrangement used where the detents and indentations were non-circular, as for example, the type shown in FIGURE 7 wherein an indexing mechanism comprises an indexing plate 11' fixedly secured to a shaft by means of a pair of flats 18' provided thereon for engaging a flat-sided opening 17'. A pair of arms 12' and 13' carrying detents 14' and 15' is resiliently biased toward the shaft by not shown springs. The detents 14' and 15' are polygonal and are received by suitable polygonal indentations provided on the periphery of the indexing plate 11'.

The relationship between the detents 14' and 15' and the indentations provided on the periphery of the indexing plate 11' is the same as the relationship between the detents and indentations shown in FIGURES 1 to 4 of the drawings, i.e., one detent is larger than each of the indentations and the other detent is smaller than each of the indentations. Thus the larger of the detents will always control the indexing mechanism because of the mechanical advantage it has over the other detent.

From the above description, it can be readily seen that this invention provides an economical and simple solution to a troublesome problem in indexing mechanisms. While this invention has been described in a preferred form and several embodiments, it is possible to produce numerous changes and modifications without departing from the inventive concept disclosed herein, and it is desired that only such limitations be imposed on the appended claims as are stated therein.

What is claimed as new and desired to be secured by Letters Patent of the United States is:

1. An indexing-detent mechanism comprising a shaft, an indexing plate mounted on the shaft for rotation therewith and provided with a plurality of spaced indentations on its periphery, each of the indentations being provided with a contact portion, a supporting plate disposed adjacent to the indexing plate, a pair of arms mounted on the supporting plate and resiliently biased toward the shaft, and a detent member mounted on each of the arms and arranged to engage one of the indentations on the periphery of the indexing plate, each of the detent members being provided with a contact portion, means rotatably supporting the indexing plate in fixed relationship to the supporting plate, the indentations and the detent members being so arranged and constructed that the contact portion of the indentation to be engaged by one of the detent members is less than the contact portion of the detent member engageable therewith and that the contact portion of the indentation engageable by the other of the detent members is greater than the contact portion of the other of the detent members.

2. The mechanism of claim 1 wherein one of the detent members is larger than the other of the detent members.

3. The mechanism of claim 1 wherein the detent members are polygonal.

4. An indexing-detent mechanism comprising a shaft, an indexing plate mounted on the shaft for rotation therewith and provided with a plurality of equally spaced arcuate indentations on its periphery, each of the indentations being defined by a curve having a radius, a detent mounting plate located adjacent the indexing plate, means rotatably supporting the indexing plate in fixed relationship to the detent mounting plate, detent means having

two arms mounted on the mounting plate and resiliently urged toward the shaft, and a circular detent member rotatably mounted on each arm and arranged to engage the indentations on the periphery of the indexing plate, each of the detent members having a radius, the radii of the indentations and the circular detent members being so arranged and constructed that the radius of the indentation to be engaged by one of the circular detent members is less than the radius of the member and the radius of the indentation engageable with the other circular detent member is greater than the radius of the other circular detent member.

5. The indexing-detent mechanism of claim 4 in which the circular detent members have the same radius.

6. The indexing-detent mechanism of claim 4 wherein the indentations have the same radius.

7. An indexing-detent mechanism comprising a shaft, an indexing plate mounted on the shaft for rotation therewith, a detent mounting plate located adjacent to and parallel with the indexing plate, means rotatably supporting the indexing plate in fixed relationship to the detent mounting plate, detent means comprising, a pair of detent arms mounted on the mounting plate, the arms being in the plane of the indexing plate and being resiliently urged toward the periphery of the indexing plate, a first circular member having a first radius rotatably mounted on one of the detent arms, a second circular member having a second radius and having a diameter larger than the first circular member rotatably mounted on the other of the detent arms, both circular members engaging the periphery of the indexing plate, and a plurality of equally spaced arcuate indentations on the periphery of the indexing plate, each indentation being defined by a curve having a third radius whereby upon rotation of the indexing plate the second circular member controls the position of the indexing mechanism.

8. The indexing-detent mechanism of claim 7 wherein the third radius is greater than the first radius and less than the second radius.

9. The indexing-detent mechanism of claim 7 in which the curves of the indentations all have the same radius.

10. In an indexing-detent mechanism, the combination of a shaft, an indexing plate fixedly mounted on the shaft and provided with peripheral indentations, a detent mounting plate disposed adjacent to the indexing plate, means rotatably supporting the indexing plate in fixed relationship to the detent mounting plate, a pair of arms pivotally secured to the mounting plate, means biasing the arms toward the shaft, and detent means mounted on each of the arms for engaging the indentations of the indexing plate and controlling the position of the indexing plate, the indentations on the indexing plate comprising different size indentations so arranged that at least a small and large indentation will always be engageable by the detent means as the shaft and indexing plate is rotated from one position to another.

References Cited by the Examiner

FOREIGN PATENTS

641,135	8/1950	Great Britain.
792,737	4/1958	Great Britain.
332,470	11/1935	Italy.

BROUGHTON G. DURHAM, *Primary Examiner*.