

Aug. 31, 1965

R. G. LANE ETAL

3,203,053

MULTIPLE WINDOW CONSTRUCTION

Filed Sept. 4, 1962

3 Sheets-Sheet 1

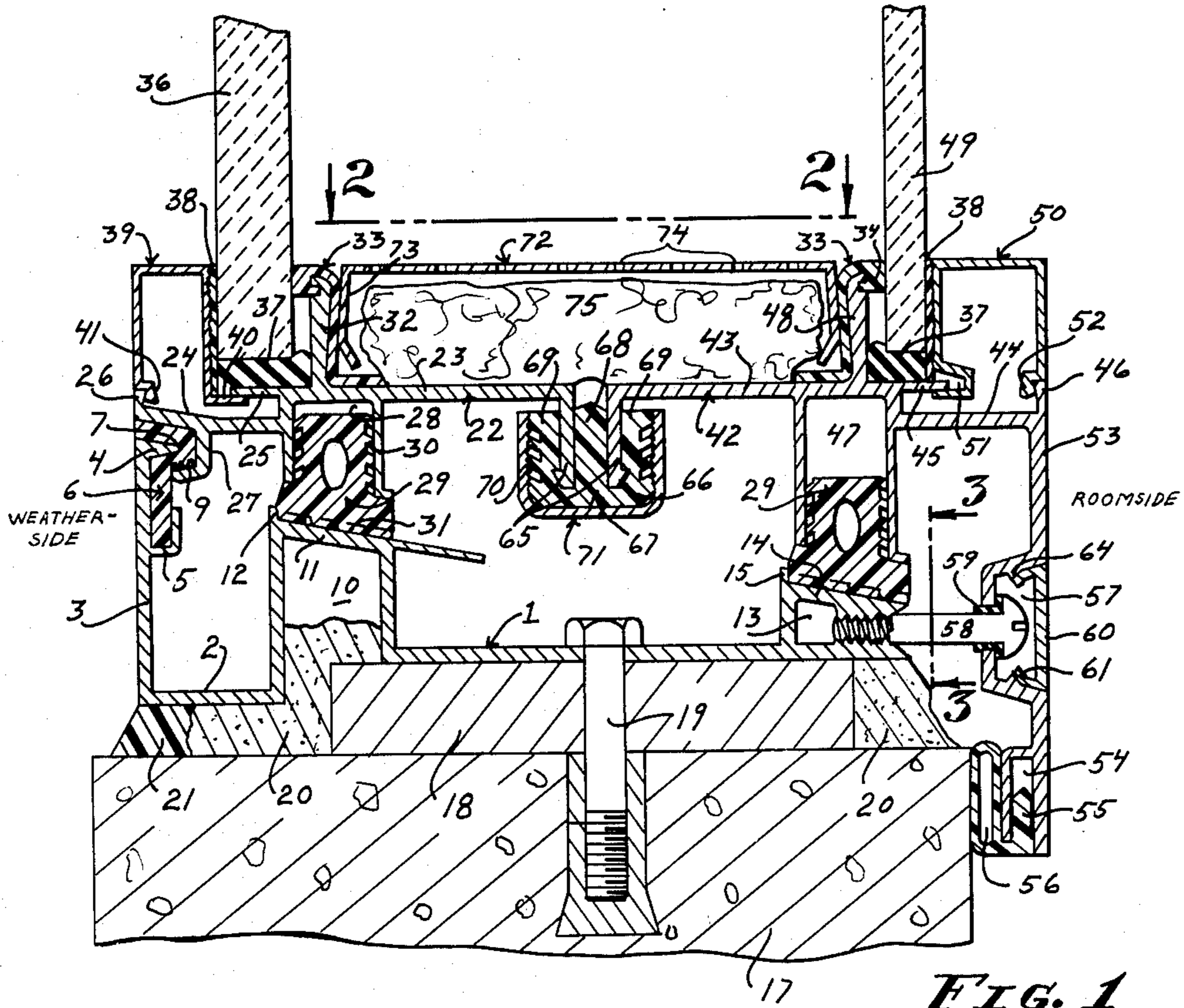

FIG. 1

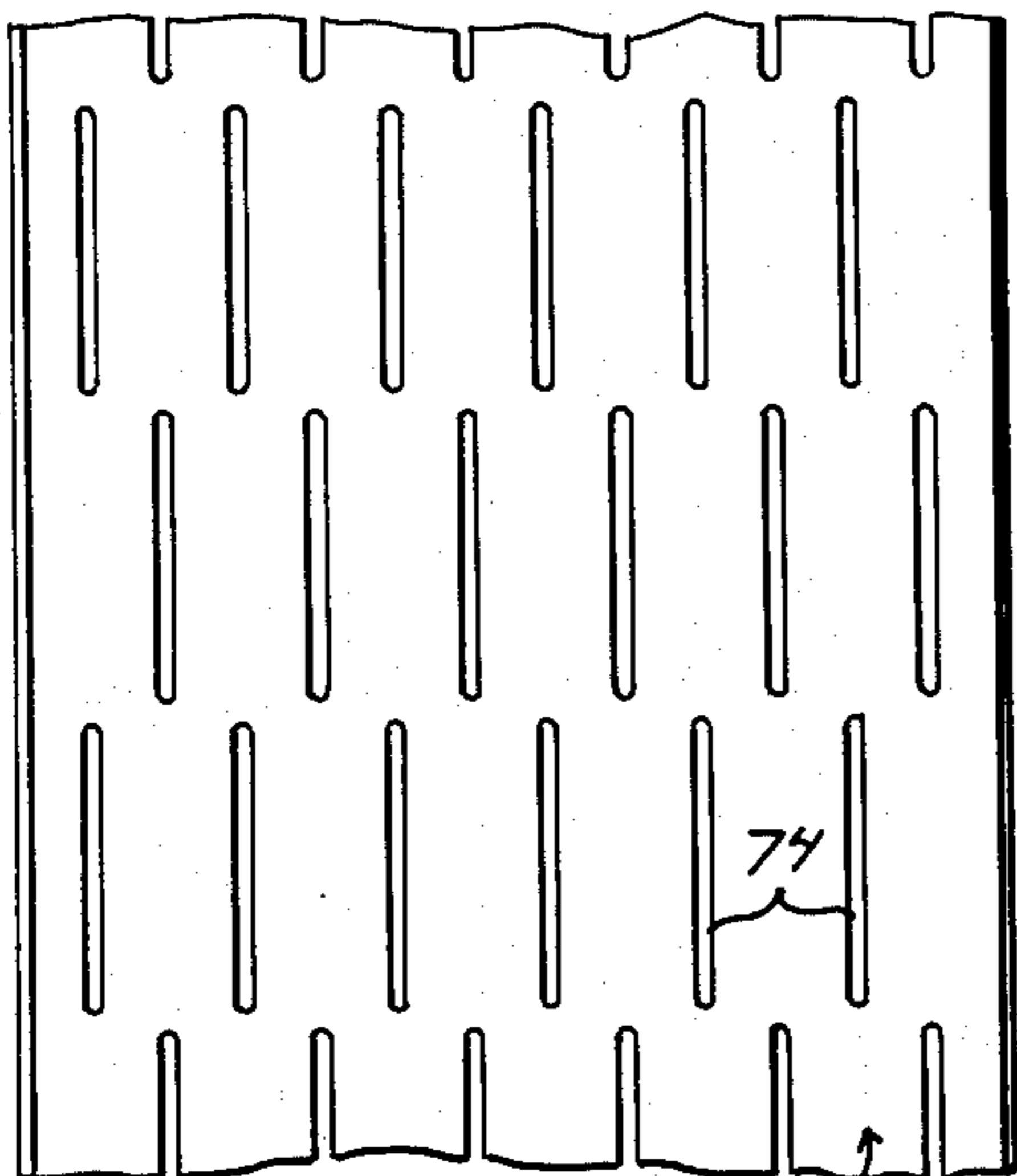

FIG. 2

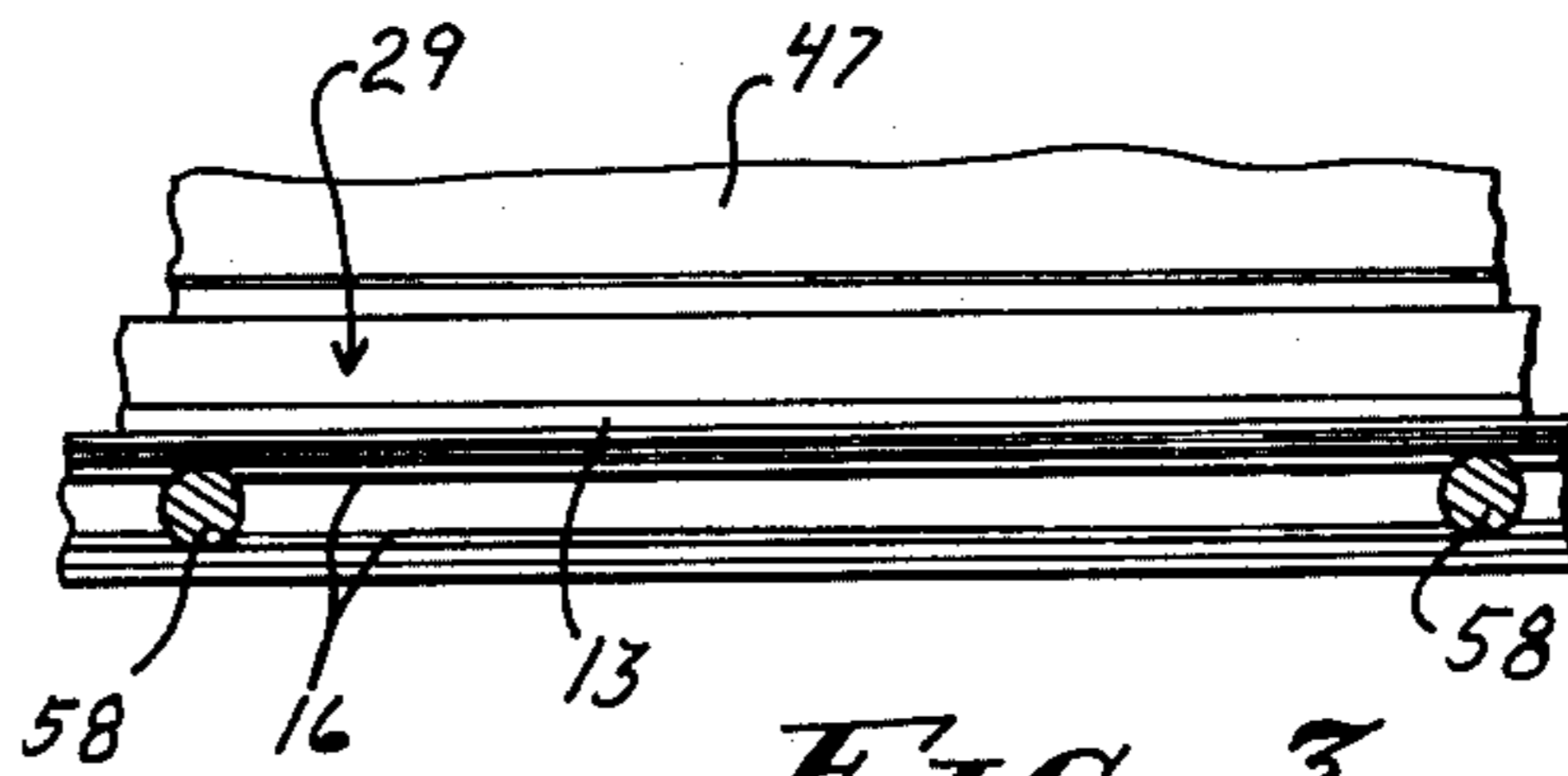

FIG. 3

RALPH G. LANE
GEORGE F. LAMB
INVENTORS

BY

Lyon & Lyon
ATTORNEYS

Aug. 31, 1965

R. G. LANE ET AL

3,203,053

MULTIPLE WINDOW CONSTRUCTION

Filed Sept. 4, 1962

3 Sheets-Sheet 2

FIG. 9

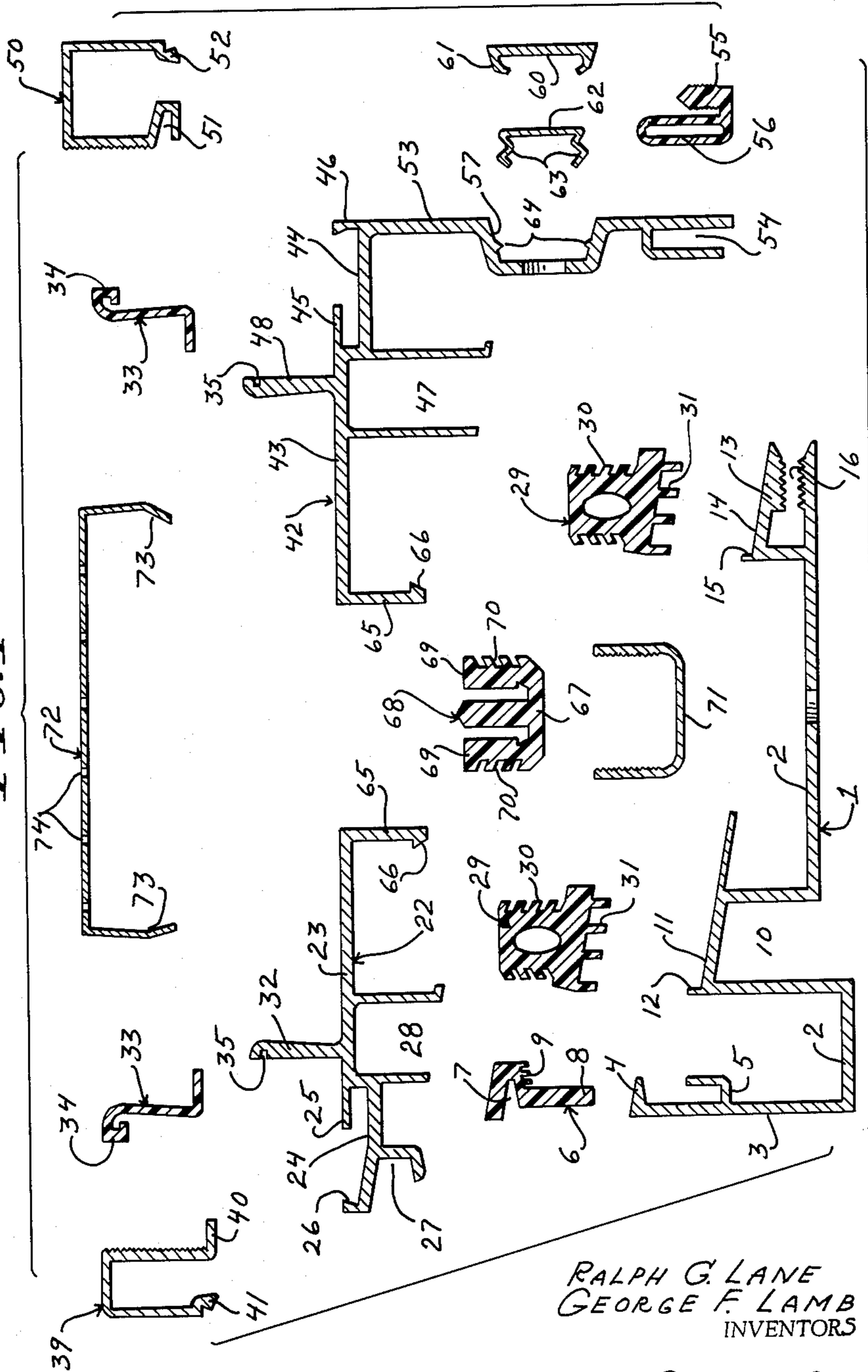

RALPH G. LANE
GEORGE F. LAMB
INVENTORS

BY *Lyon & Lyon*
ATTORNEYS

Aug. 31, 1965

R. G. LANE ETAL

3,203,053

MULTIPLE WINDOW CONSTRUCTION

Filed Sept. 4, 1962

3 Sheets-Sheet 3

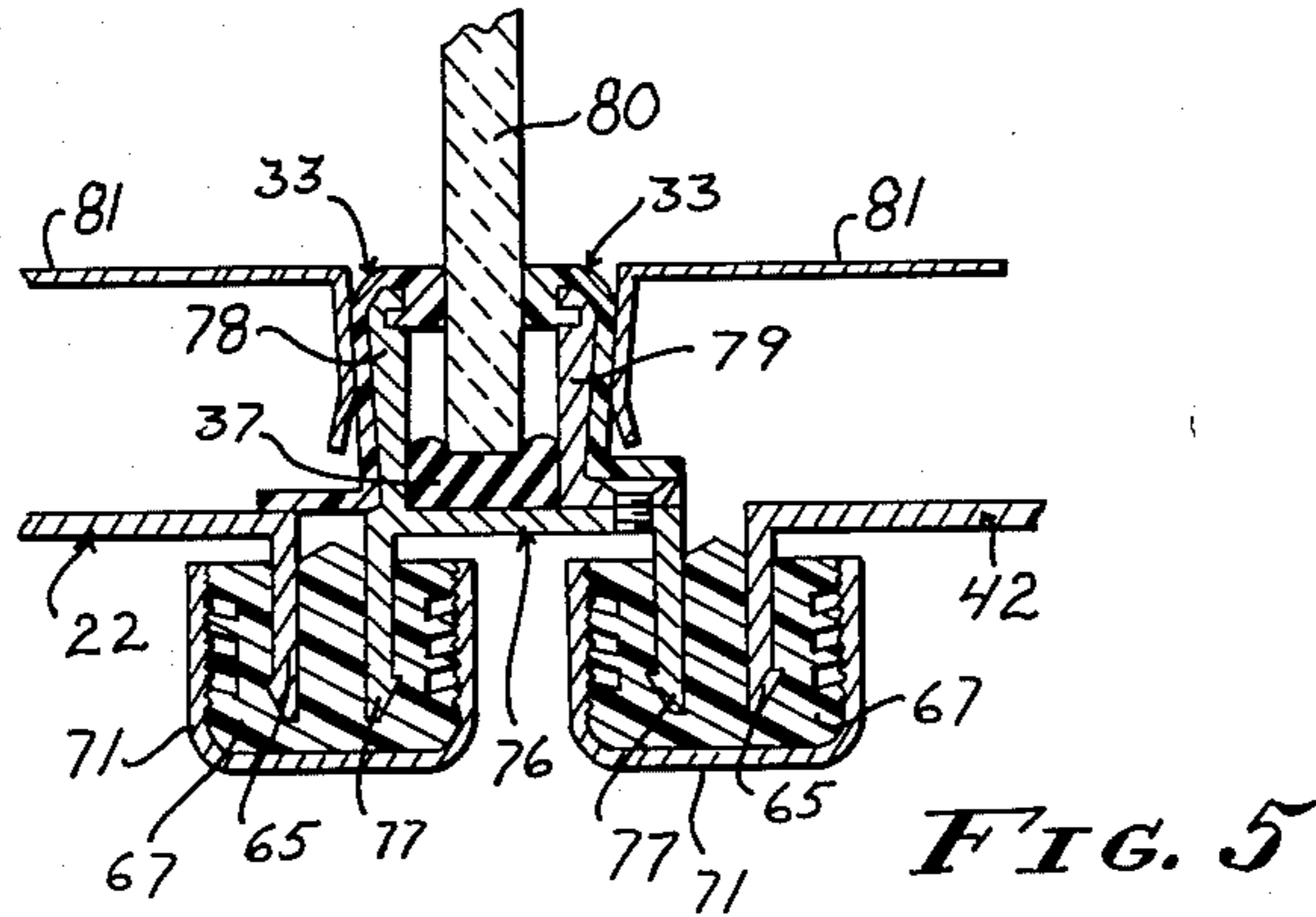

FIG. 5

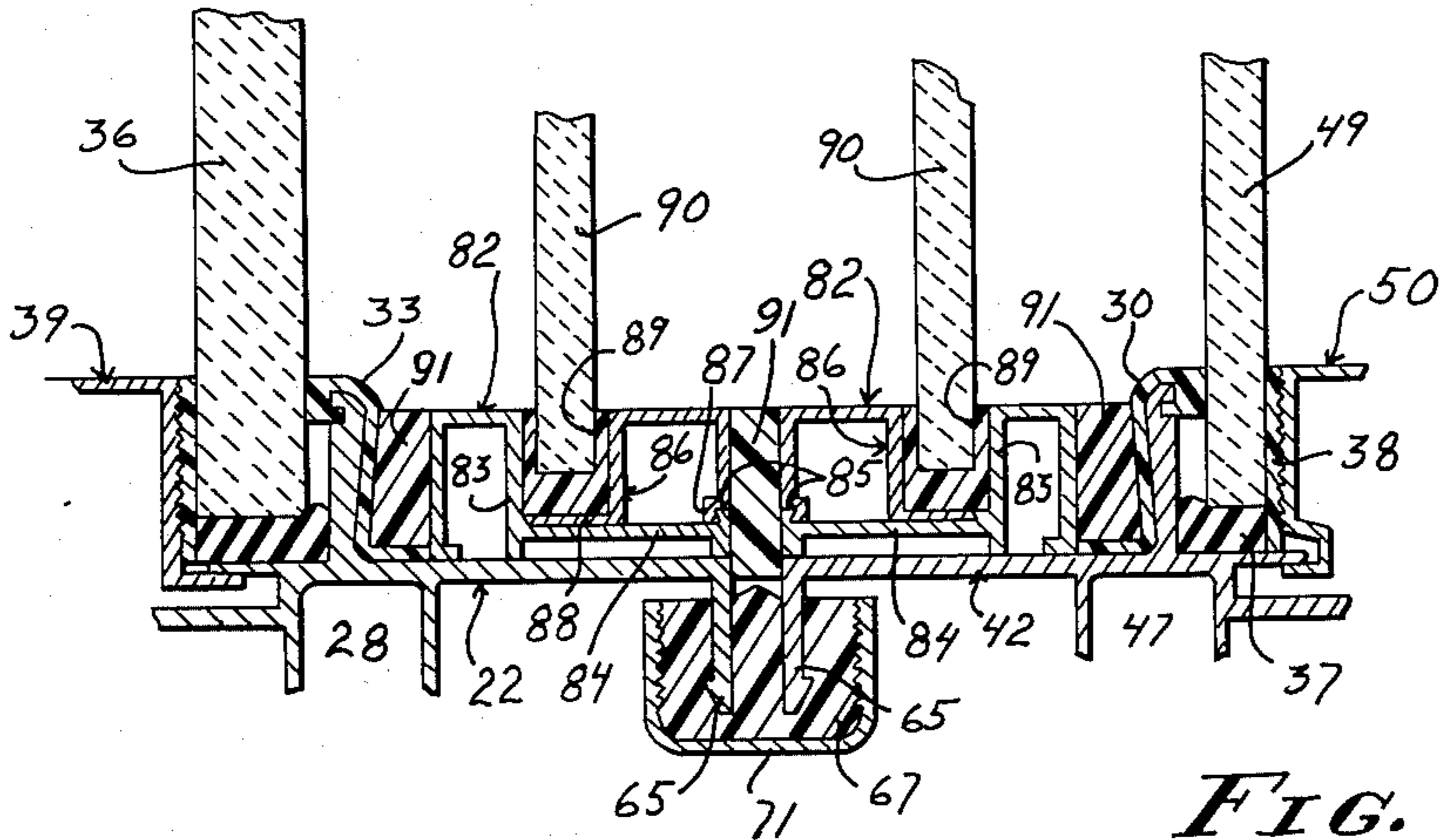

FIG. 6

RALPH G. LANE
GEORGE F. LAMP
INVENTORS

BY *Lyon Lyon*
ATTORNEYS

1

3,203,053

MULTIPLE WINDOW CONSTRUCTION

Ralph G. Lane, Altadena, Calif., and George F. Lamb, Washington, D.C., assignors to Frank B. Miller Mfg. Co. Inc., Burbank, Calif., a corporation of California
 Filed Sept. 4, 1962, Ser. No. 220,996
 13 Claims. (Cl. 20—56.5)

This invention relates to multiple window constructions, and included in the objects of this invention are:

First, to provide a multiple window construction wherein the inner and outer windowpanes, as well as their respective substructures, are isolated thermally and vibrationally from each other so as to minimize the transmission of heat and vibration, inwardly or outwardly, through the window construction.

Second, to provide a multiple window construction wherein, after installation of a peripheral frame component, the preassembled remaining components of the window may be installed as a unit, thus permitting factory assembly of the major components of the multiple window construction.

Third, to provide a multiple window construction which incorporates novel means to facilitate insertion of the preassembled components of the window into the peripheral frame component.

Fourth, to provide a multiple window construction wherein virtually all the parts may be formed of metal or elastomer extrusions.

Fifth, to provide a multiple window which provides a concealed space between the windowpanes to receive a desiccant in order to ensure a moisture-free interior.

With the above and other objects in view, as may appear hereinafter, reference is directed to the accompanying drawings in which:

FIGURE 1 is a typical transverse, sectional view through any of the four sides of the window construction, arranged as a double window;

FIGURE 2 is a fragmentary plan view of the acoustical pan installed between the windowpanes, the view being taken from 2—2 of FIGURE 1;

FIGURE 3 is a fragmentary, sectional view taken through 3—3 of FIGURE 1, showing particularly the means whereby bolts extending from one of the inner frame members are joined to the outer frame member;

FIGURE 4 is an exploded view showing the major components of the double window construction in cross section;

FIGURE 5 is a fragmentary sectional view, similar to FIGURE 1, showing a modification wherein the window is arranged as a triple window construction;

FIGURE 6 is another fragmentary sectional view, showing a further modification wherein the window is arranged as a quadruple window construction.

Reference is first directed to FIGURES 1 through 4. The double window construction here illustrated is formed almost entirely from a plurality of extruded metal parts which are separated from each other by yieldable sealing and cushioning means, which are also extrusions, in this case formed of rubber or other elastomer.

The double window construction includes an outer mounting frame member 1 which is formed into a rectangular outer frame structure. The mounting frame member 1 includes a transverse web 2 provided along its weatherside margin, or left side margin as viewed in the drawings, with an internally directed weatherside flange 3. The flange 3 terminates in an inturned lip 4 and is provided along its inner wall, confronting the inturned lip, with a retainer bracket 5 of angular cross section.

The inturned lip 4 and retainer bracket 5 receive a

2

sealing member 6, formed of rubber or other elastomer, and having a V-shaped end 7 which fits over the inturned lip 4 and a lateral flange 8 which extends into and is retained by the bracket 5. The side wall of the V-shaped end 7, which faces toward the web 2, is provided with parallel sealing lips 9. The function of the sealing member 6 will be brought out more fully hereinafter.

Near the weatherside flange 3, the web 2 is interrupted by a channel-shaped mounting pad 10, extending internally from the web member, and terminating in an inclined ramp surface 11 which slopes toward the roomside margin of the web 2, that is, away from the weatherside flange 3. The ramp surface 11 may include an extension which projects laterally from the mounting pad 10. The margin of the ramp surface 11, nearest the weatherside flange 3, is provided with a stop 12.

The roomside margin of the web 2 is provided with a roomside mounting pad 13 terminating in a ramp or inclined surface 14, disposed at a lesser height from the web 2 than the ramp surface 11. The ramp surface 14 is also provided with a stop 15 corresponding to the stop 12. When the mounting frame member 1 is formed into a rectangular frame structure, the opening defined by the outside mounting pad 10 is smaller than the opening defined by the inside mounting pad 13.

The roomside mounting pad 13 is provided with a slot which is open towards the roomside margin of the web 2. The confronting walls of the slot are provided with screw-receiving serrations 16.

The rectangular, outer window frame structure, formed by the mounting frame member 1, is set into a window opening provided in a building wall 17 and supported relative to the sides of the opening by suitable shims or mounting blocks 18. Bolts 19 secure the outer frame structure in place. In addition, grouting or other cementitious material is placed between the roomside and weatherside margins of the web 2 and the surrounding walls of the window opening. At the weatherside margin of the web 2, a suitable sealant 21 is also applied.

The weatherside portion of the outer frame structure formed by the mounting frame member 1 receives a weatherside windowpane frame member 22 formed into a rectangular frame substructure. The weatherside windowpane frame member 22 includes a cross web 23 having a weatherside end 24 offset toward the mounting frame member 1. A weatherside-directed lip 25 overlies the offset weatherside end 24 and an internally directed catch lip 26 confronts the lip 25.

At the side of the offset end 24 confronting the web 2, there is formed a weatherside facing channel 27 which conforms to the V-shaped end 7 of the sealing member 6, and is sealingly engaged by the sealing lips 9.

The web 23 of the weatherside windowpane frame member 22 is provided with an external mounting channel 28 directed toward and in registry with the weatherside mounting pad 10. The mounting channel 28 receives a mounting cushion 29, formed of rubber or other elastomer, and having lateral sealing lips 30 which engage the side walls of the mounting channel 28 and peripheral sealing lips 31, which seat on the inclined ramp surface 11 in a folded condition. Between the ramp 11 and the mounting channel 28, the cushion 29 is provided with lateral shoulders to limit entrance of the cushion into the channel.

Disposed internally of the cross web 23 is a weatherside windowpane stop flange 32 around which is wrapped a gasket strip 33, formed of rubber or other elastomer, and having an interlocking flange 34, the extremity of which is received in a groove 35 provided in the stop flange 32. The opposite margin of the gasket strip 33

overlies a portion of the web 23 adjacent the stop flange 32.

A weatherside windowpane 36 is located at the weatherside of the stop flange 32, over the lip 25. Its margins yieldably bear against the interlocking flange 34 of the gasket strip, and the windowpane is positioned within the rectangular opening formed by the weatherside windowpane frame member by means of mounting blocks 37, formed of rubber or other elastomer. The weatherside margin of the windowpane 36 receives a sealant strip 38, formed of rubber or other elastomer, and which may be coated with a pressure-sensitive adhesive.

Fitted against the weatherside margin of the windowpane 36 is a weatherside window-framing member 39 of channel-shaped cross section, the flanges of which are directed externally: one flange member terminates in a lateral portion 40 which fits under the lip 25; the other flange of the framing member 39 terminates in a latching lip 41 which engages the catch lip 26.

The roomside portion of the mounting frame member 1 accommodates a roomside windowpane frame member 42 having a transverse web 43. The roomside margin of the web 43 is offset as indicated by 44, corresponding to the offset weatherside end 24. Similarly, the offset end 44 is provided with an overhanging lip 45 which confronts a catch lip 46 at the extreme roomside end. Adjacent the offset end 44, the web 43 is provided with mounting channel 47, corresponding to the mounting channel 28, but of greater depth. The mounting channel 47 receives a second mounting cushion 29 which engages the roomside mounting pad 13.

The web 43 is provided at a side opposite from the mounting channel 47 with a roomside windowpane stop flange 48 corresponding to the weatherside windowpane stop flange 32. The flange 48 is equipped with a gasket strip 33 having an interlocking flange 34 wrapped over the extremity of the stop flange. A roomside windowpane 49 rests against the interlocking flange 34 and is peripherally supported by mounting blocks 37.

The roomside margin of the windowpane 49 is covered by a roomside window framing member 50 of channel shaped cross section corresponding to the weatherside window framing member 39. The framing member 50 is provided with a laterally facing marginal channel 51 which interlocks with the lip 45 and a latching lip 52 which engages the catch lip of 46. A sealant strip 38 is interposed between the framing member 50 and the roomside windowpane 49. The surfaces of the two framing members 39 and 50 covered by the sealant strips 38 are preferably serrated or otherwise roughened to provide interengagement with the surface of the sealant strip.

The roomside margin of the web 43 is provided with a roomside cover plate or flange 53 which covers the mounting frame member 1 and overlies the margin of the building wall 17 surrounding the window opening. The roomside cover plate 53 is provided at its margin remote from the web 43 with a slot 54 directed away from the web 43. The slot 54 receives an offset flange 55 formed of rubber or other elastomer, and attached to a sealing tube 56 interposed between the marginal portion of the cover plate 53 and the wall 17.

The roomside face of the cover plate 53 is provided with a channel 57 disposed in registry with the slotted edge of the mounting frame member 1 having the screw-receiving serrations 16 therein. Screws or bolts 58 extend through openings in the channel 57 and screw thread between the serrations 16. The head of each bolt is provided with a grommet 59 formed of rubber or other elastomer. The channel 57 is covered by a cover strip 60 having inturned flanges 61. Fitted between the inturned flanges 61 are a plurality of retainer clips 62 of channel shaped cross section and including spring flanges 63 which engage internal ribs 64 provided within the channel 57.

The cross webs 23 and 43 of the weatherside and roomside windowpane frame members 22 and 42 are disposed

in a common plane and terminate in confronting relation to each other. The confronting margins of the webs are provided with flanges 65 which extend toward the mounting frame member 1 in parallel relation to each other. The extremities of the flanges 65 have outturned retainer lips 66. The confronting flanges 65 are connected by a vibration isolating and sealing member 67 formed of rubber or other elastomer. The isolating member is essentially W-shaped; that is, the isolating member includes a central flange 68 which fits between the confronting flanges 65 and side flanges 69 overlying the remote sides of the flanges 65. The outer surfaces of the side flanges 69 are provided with sealing lips 70. The isolating member 67 is adapted to fit within a retainer member 71 of channel-shaped cross section. The side walls of the retainer member which fit over the sealing lips 70 are serrated to assure a sealing connection and also to secure the retainer member 71 on the isolating member 67.

The space between the gasket strips 33 which cover the windowpane stop flanges 32 and 48 receives an acoustical pan 72 having side flanges 73 which bear yieldably against the gasket strips 33. The web of the acoustical pan between the flanges 73 is provided with slots 74 or is otherwise perforated in a suitable pattern. The space between the acoustical pan and the frame members 22 and 42 is filled with a sound-absorbing material 75 and desiccant. The sound-absorbing material may be glass wool or fibrous material. The desiccant may be silica gel.

The window construction is installed as follows:

An outer frame structure is formed from four of the mounting frame members 1 and is set in place within a window opening. The sealing member 6 is fitted over the weatherside of flange 3. The remaining components of the window construction are preassembled as a unit and then slipped laterally within the outside frame structure. The mounting cushions 29 ride on the ramp surfaces 11 and 14. The weatherside facing channel 27 engages the sealing member 6 and the bolts 58 are screw threaded into the serrations 16 so as to draw the roomside cover plate 53 and sealing tube 56 snugly against the roomside wall surface.

It will be noted that the weatherside windowpane carrying substructure is isolated from the roomside windowpane carrying substructure by reason of the gasket strips 33 and isolating member 67. Both of these substructures are isolated from the outer frame structures by the mounting cushions 29. The weatherside windowpane substructure is also isolated from the outer frame structure by the sealing member 6, and, correspondingly, the roomside windowpane substructure is isolated from the wall by the sealing tube 56 and is isolated from the outer frame structure by the grommets 59 surrounding the head ends of the bolts 58. As a consequence the transmission of noise or vibration in either direction through the window is materially reduced.

It will also be noted that the various components of the window construction may be rapidly disassembled; and inasmuch as the inner window frame structure comprising the two substructures, which carry the weatherside and roomside windowpanes, is installed as a unit, this assembly may take place at a factory rather than at the point of use, and may be accomplished at a minimum of expense and time. Such factory assembly also ensures a hermetically sealed compartment between the two windowpanes.

Reference is now directed to FIGURE 5, which illustrates a modified form of the window construction adapted as a triple-pane window. The construction is the same as that shown in the first described structure, except that the frame members 22 and 42 are separated to provide space for a center window frame member 76.

The center window frame member 76 is channel-shaped and provided with flanges 77, similar to the confronting flanges 65 of the frame members 22 and 42. The frame

members 22, 76 and 42 are connected in series by a pair of isolating members 67 held in the retaining channels 71.

The center window frame member 76 is provided with a fixed stop flange 78, corresponding to the flanges 32 and 48, and a removable stop flange 79 secured to the frame member 76 by screws. The stop flanges define a channel which receives a window 80 which rests on the mounting blocks 37 in the manner of the windowpanes 36 and 49. Gasket strips 33 center the pane between the flanges 78 and 79. In this construction two acoustical pans 81 are used which are similar to the acoustical pan 72 except that they have less width.

Reference is now directed to FIGURE 6. In this construction, the double window arrangement shown in FIGURE 1 is utilized without change except that the acoustical pan 72 is omitted, and, instead, two window frame members 82 are provided. Each window frame member 82 includes a channel-shaped stop 83 from which extends a lateral shelf 84 terminating in a latch bead 85.

Fitted over the shelf is a channel-shaped retainer member 86 having a latching means 87 which cooperates with the latch bead 85. The retainer member 86 includes a lateral lip 88 which extends toward the channel stop 83 and forms therewith an inwardly open channel having a cushion 89 which receives a windowpane 90.

The two window frame assemblies are mounted between the gasket strips 33 and the excess space is filled with separator strips 91, of rubber or other elastomer.

It will be noted that if only three panes are required, one of the central windowpane units may be omitted and an acoustical pan of appropriate width substituted.

While particular embodiments of this invention have been shown and described, it is not intended to limit the same to the exact details of the constructions set forth, and it embraces such changes, modifications, and equivalents of the parts and their formation and arrangement as come within the purview of the appended claims.

We claim:

1. An acoustical window construction, comprising:
 - (a) an inner frame structure including a weatherside substructure, a roomside substructure, and yieldable cushioning means sealingly connecting said substructures to minimize transmission of sonic vibration therebetween;
 - (b) an outer frame structure;
 - (c) a spaced peripheral mounting means disposed between said outer frame structure and each of said substructures, each of said mounting means including a peripheral mounting pad and a cushioning element to minimize transmission of sonic vibration between said outer frame structure and said substructures;
 - (d) one of said mounting means having a smaller periphery than the other, and both of said mounting means being laterally tapered whereby said mounting means are laterally separable to permit insertion and withdrawal of said inner frame structure as a unit;
 - (e) means for forcing said inner frame structure laterally with respect to said outer frame structure and relatively securing said frame structures;
 - (f) a windowpane for each substructure;
 - (g) and cushion mounting means between said substructures and their respective windowpanes to minimize transfer of vibration therebetween.
2. An acoustical window frame construction comprising:
 - (a) an outer frame structure defining a window opening and including a weatherside and roomside inwardly directed mounting pad;
 - (b) an inner frame structure including a weatherside and roomside outwardly directed mounting means adapted to fit said mounting pads, said roomside mounting means and pad defining an opening of greater peripheral extent than the weatherside mount-

ing means and pad to permit lateral insertion of said inner frame structure into said outer frame structure;

- (c) said outer frame structure defining a peripheral roomside directed channel having serrated confronting walls and said inner frame structure including a flange overlying said channel;
 - (d) and screwthreaded means extending from the flange of said inner frame structure engaging said serrated walls and securing said inner frame structure relative to said outer frame structure.
3. An acoustical double window frame construction, comprising:
 - (a) an outer frame structure defining a window opening and including a weatherside and roomside inwardly directed mounting pad;
 - (b) an inner frame structure including a weatherside substructure, a roomside substructure, yieldable cushion means joining said substructures to minimize transmission of sonic vibration therebetween, and a yieldable mounting cushion for each substructure to support said inner frame structure within said outer frame structure;
 - (c) said roomside mounting pad and cushion defining a larger opening than the weatherside mounting pad and cushion to permit lateral insertion of said inner frame structure into said outer frame structure;
 - (d) said mounting cushions minimizing transmission of sonic vibration between said substructures and said outer frame structure;
 - (e) said outer frame structure defining a peripheral roomside directed channel having serrated confronting walls and said inner frame structure including a flange overlying said channel;
 - (f) and screwthreaded means extending from the flange of said inner frame structure engaging said serrated walls and secure said inner frame structure relative to said outer frame structure.
 4. An acoustical double window construction comprising:
 - (a) an outer frame structure including an inwardly directed flange framing its weatherside, an inwardly directed weatherside mounting pad adjacent said flange, and an inwardly directed roomside mounting pad at the roomside portion of said outer frame structure;
 - (b) an inner frame structure including a weatherside substructure, a roomside substructure, and yieldable sound deadening means joining said substructure;
 - (c) each substructure including an outwardly directed mounting means disposed for cooperation with a corresponding mounting pad;
 - (d) yieldable sound deadening means interposed between said mounting means and said mounting pads;
 - (e) said roomside substructure having a roomside cover flange overlying the roomside margin of said outer frame structure;
 - (f) securing elements, including yieldable sound deadening means, joining said roomside flange of said inner frame structure to said outer frame structure;
 - (g) other yieldable sound deadening means between said weatherside substructure and the inwardly directed framing flange of said outer frame structure;
 - (h) laterally inner and outer window panes;
 - (i) and yieldable sound deadening means for mounting said windowpanes in said substructures.
 5. An acoustical window construction, comprising:
 - (a) an outer frame structure;
 - (b) an inner frame structure including a weatherside substructure, an intermediate substructure, and a roomside substructure, and a sound isolating yieldable cushioning means sealingly interconnecting said substructures to minimize transmission of vibration therebetween;
 - (c) peripheral sound isolating yieldable cushions interposed between said outer frame structure and each of said weatherside and roomside substructures to sup-

- port said inner frame structure and minimize transmission of vibration therebetween;
- (d) said intermediate substructure having a pair of outwardly directed flanges, and each of said weatherside and roomside substructures having a flange confronting and spaced from said intermediate substructure flange;
- (e) a windowpane for each substructure;
- (f) and sound isolating yieldable cushion mounting means between said substructures and their respective windowpanes to minimize transfer of vibration therebetween, each of said cushioning means including a slotted elastomer receiving said confronting flanges and a shell partially enclosing said elastomer.
6. An acoustical window construction, comprising:
- (a) an outer frame structure including an inwardly directed weatherside pad and an inwardly directed roomside pad;
- (b) a weatherside inner subframe structure and a roomside inner subframe structure spaced therefrom, each subframe structure including an outwardly directed peripheral channel confronting the weatherside and roomside pads respectively;
- (c) sound isolating cushioning members yieldably fitting said channels and yieldably seated on said pads;
- (d) a windowpane for each subframe structure;
- (e) and yieldable sound isolating cushioning means interposed between each window and its subframe structure.
7. An acoustical window construction as set forth in claim 6, wherein:
- (a) said subframe structures have spaced confronting margins and outwardly directed confronting flanges at said margins;
- (b) a sound isolating cushioning and connecting member is interposed between and embraces said flanges;
- (c) and a channel-shaped retainer embraces said connecting member.
8. An acoustical window construction as set forth in claim 6, wherein:
- (a) said pad-engaging cushioning members are provided with lateral shoulders to limit entrance into said channels, yieldable lateral ribs engageable with the walls of said channels, and flexible peripheral ribs engageable with said pads to minimize sound transmission between said outer frame structure and said subframe structures.
9. An acoustical window construction as set forth in claim 6, wherein:
- (a) the weatherside margin of said outer frame structure and the corresponding margin of said weatherside subframe are provided with a confronting spaced rib and channel forming a labyrinthine passageway;
- (b) and a sound isolating sealing and cushioning member is fitted in said passageway.
10. An acoustical window construction as set forth in claim 6, wherein:

- (a) the roomside margin of said outer frame structure is provided with a roomside directed channel having serrated walls to receive fastening means;
- (b) the corresponding margin of said roomside subframe structure is provided with an outwardly directed flange confronting said channel;
- (c) fastening means extend from said flange into said channel;
- (d) and a wall-engaging sound isolating cushion is carried by said flange.
11. An acoustical window construction as set forth in claim 6, wherein:
- (a) at least one intermediate inner subframe is interposed between and spaced from said weatherside and roomside subframes;
- (b) said subframes have outwardly directed flanges disposed in confronting spaced pairs;
- (c) a sound isolating cushioning and connecting member is interposed between and embraces each pair of flanges;
- (d) and a channel-shaped retainer embraces each of said connecting members.
12. An acoustical window construction as set forth in claim 6, wherein:
- (a) said subframes are provided with inwardly directed flanges each backing a marginal edge of the respective windowpane, said flanges defining therebetween an inwardly directed peripheral channel;
- (b) sound absorbing padding fills said channel;
- (c) a cover encloses said padding;
- (d) and sound isolating members isolate said cover from said subframes.
13. An acoustical window construction as set forth in claim 6, wherein:
- (a) said subframes are provided with inwardly directed flanges backing the margins of said windowpanes, said flanges defining therebetween an inwardly directed peripheral channel;
- (b) at least one additional windowpane and a frame therefor is mounted in said channel;
- (c) and sound isolating means is interposed between said additional windowpane frame and said subframes.

References Cited by the Examiner

UNITED STATES PATENTS

2,264,176	11/41	Englehart et al.	20—56.5	X
2,303,149	11/42	Verhagen.		
2,781,111	2/57	Kunkel	189—75	
2,877,515	3/59	Haas	20—56.5	
3,018,524	1/62	Schlegel	292—342	X
3,055,468	9/62	Horejs et al.	189—76	X

HARRISON R. MOSELEY, *Primary Examiner*.
 CHARLES E. O'CONNELL, *Examiner*.