

Jan. 28, 1964

A. C. BOOKMAN  
LIQUID FILLED DIE AGITATOR CONTAINING A DIE HAVING  
RAISED INDICIA ON THE FACETS THEREOF  
Filed Jan. 2, 1962

3,119,621

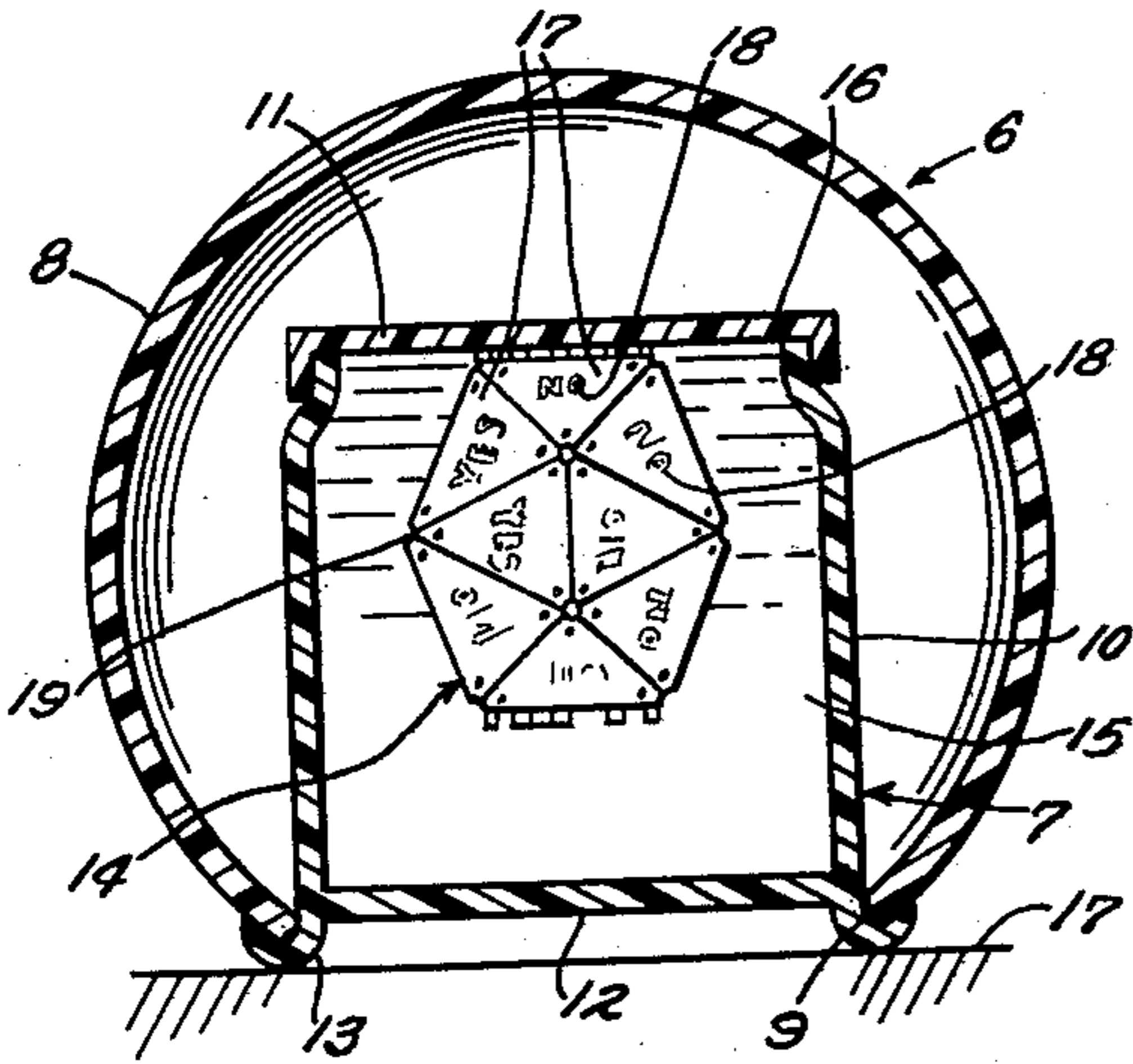

Fig. 1

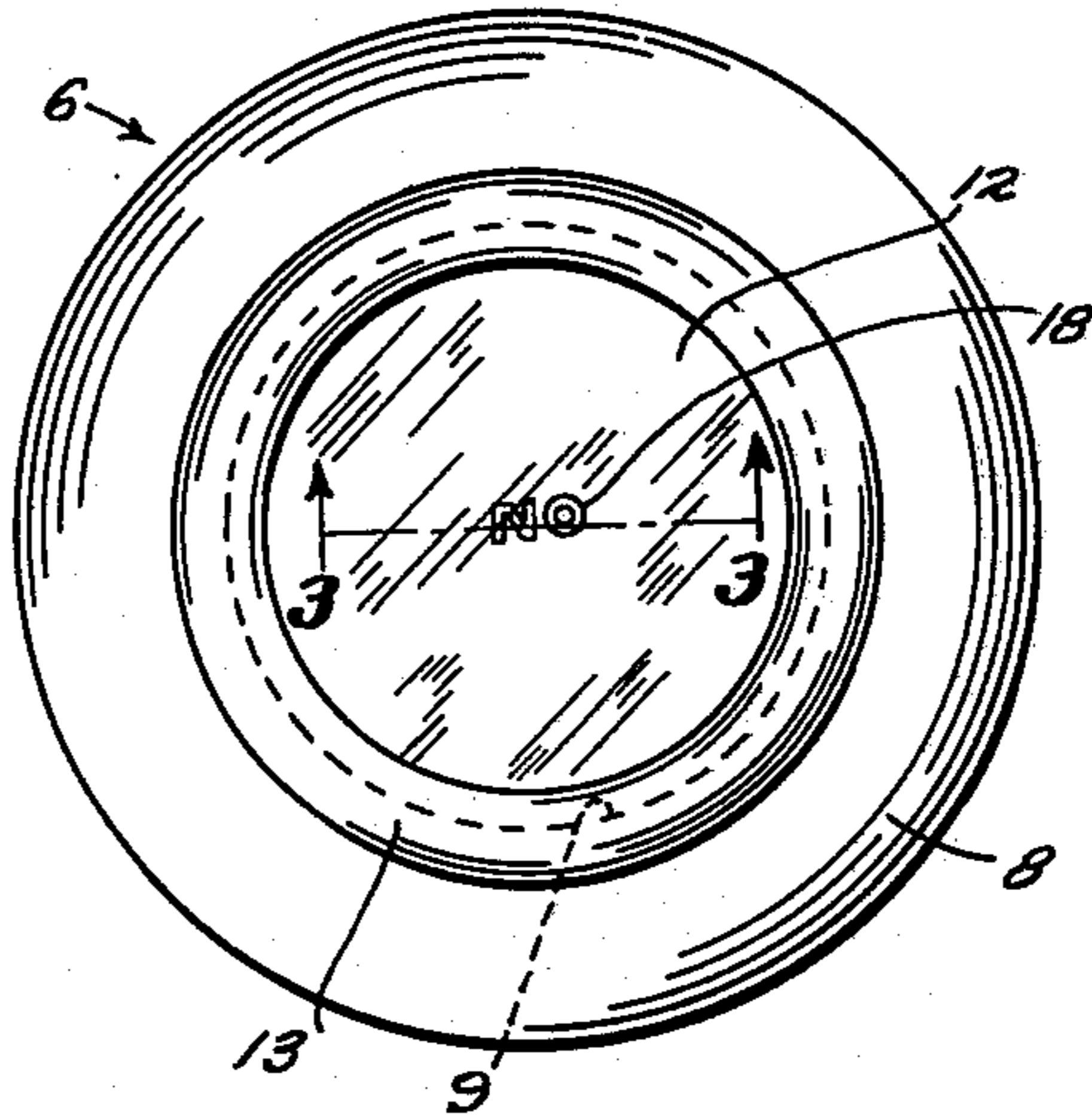

Fig. 2

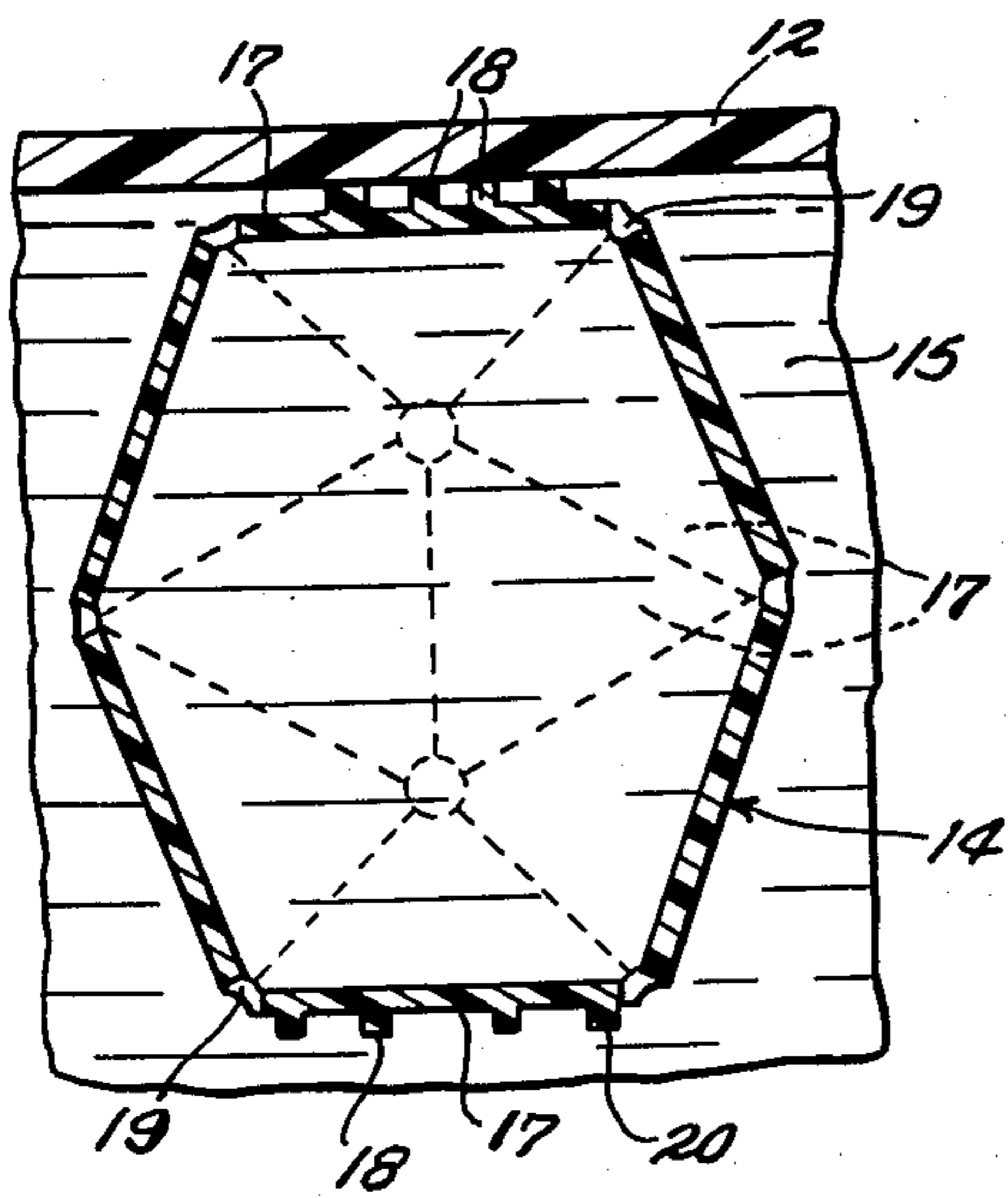

Fig. 3

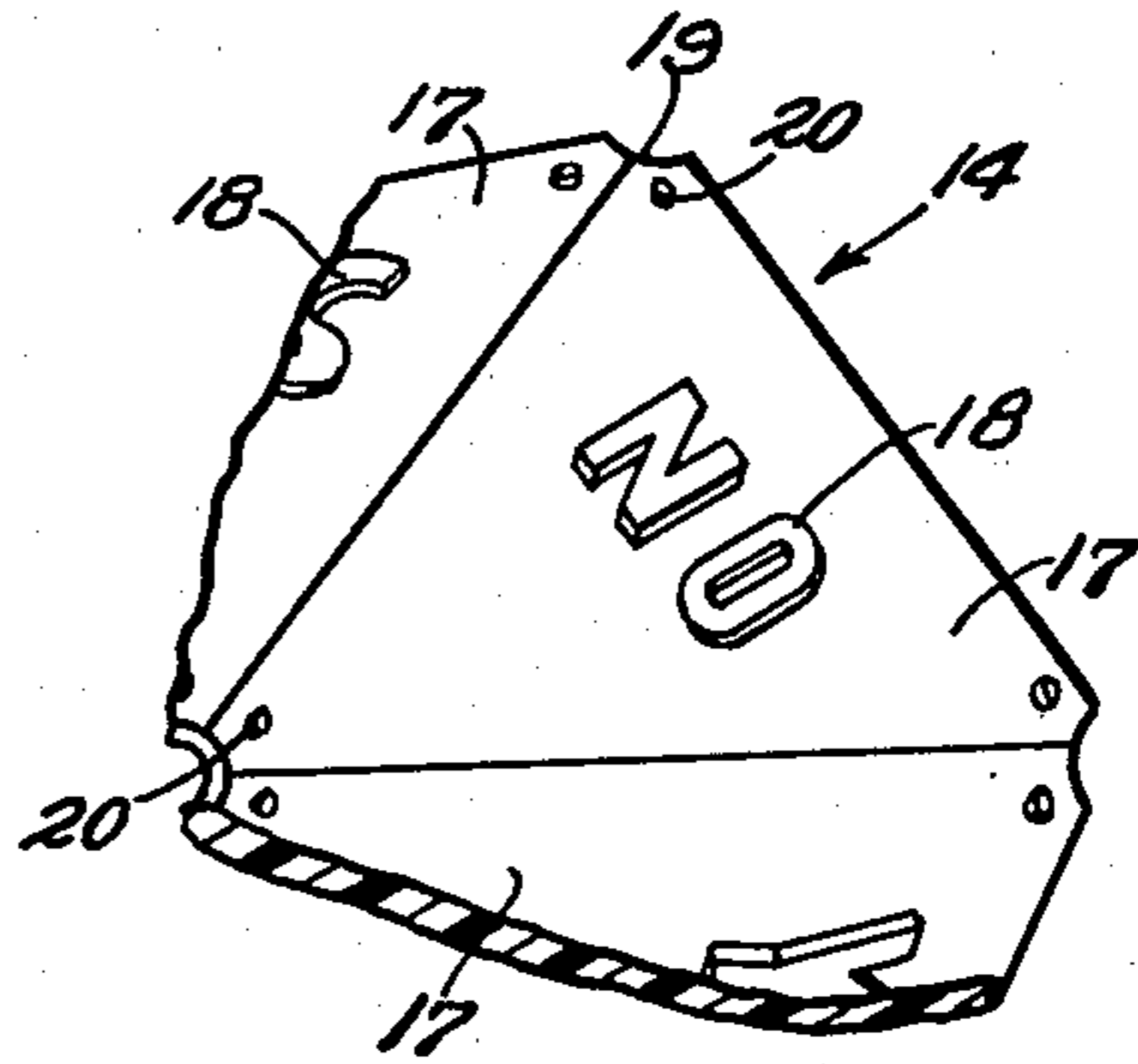

Fig. 4

INVENTOR.  
Abe C. Bookman

BY

*Arthur S. Murray*  
ATTY



1

3,119,621

**LIQUID FILLED DIE AGITATOR CONTAINING A DIE HAVING RAISED INDICIA ON THE FACETS THEREOF**

Abe C. Bookman, % Alabe Crafts, 348 W. 5th St., Cincinnati, Ohio

Filed Jan. 2, 1962, Ser. No. 163,674  
4 Claims. (Cl. 273-145)

This invention relates to improvements in liquid filled die agitators and is particularly directed to a novel die structure that co-operates with the agitator parts to secure desirable and practical advantages over prior devices.

In the past liquid filled die agitators have been provided. Such agitators were relatively expensive to produce due to the required characteristics of the buoyant, multi-faced die member therefor and the application of different and informative sets of indicia on each of the said faces. Such buoyant die members required many steps in their manufacture which increased the production costs of each agitator whilst the die members so produced did not present to view uniform and distinct sets of indicia and often functioned unsatisfactorily in that a relatively long elapsed time was required to operate the agitator because the face of the member would adhere too long to the end walls of the agitator.

The present invention is designed to overcome all of the shortcomings mentioned heretofore and to this end an important object is to provide in a device of the character described a multi-faced, buoyant die member that has a set of embossed indicia on each of its facets, such set of indicia being of uniform height and co-operable with the inside face of a transparent end wall of the opaque liquid container for the agitator whereby the set of indicia will be clearly and distinctly visible through the said end wall while the facet carrying said set will be maintained in spaced relation beneath the window and concealed from view by the intervening liquid.

Another object of the invention is to provide a means for greatly reducing surface tension between each of the facets of a buoyant die member and the end walls of the liquid filled container thus increasing the responsiveness and dependability of the agitator.

A further object of the invention is to provide a greatly simplified yet improved buoyant die construction for a liquid filled die agitator of the class described.

Further objects of the present invention and certain other improvements and practical advantages will be apparent from the following description of the preferred embodiment of the invention, said embodiment being illustrated in the accompanying drawings, in which:

FIG. 1 is a central, sectional view of my liquid filled die agitator.

FIG. 2 is a plan view of the bottom of the agitator shown in FIG. 1 when it is inverted end-for-end from the position illustrated in FIG. 1.

FIG. 3 is a greatly enlarged section taken on line 3-3 of FIG. 2.

FIG. 4 is an enlarged, fragmental perspective view of a portion of the buoyant die member for my agitator shown in FIGS. 1-3 of the drawings.

Referring to the drawing in detail the reference numeral 6 generally indicates a liquid filled die agitator composed of an inner, closed chamber 7 and a decorative outer shell or casing 8, the latter preferably having the form of a truncated sphere. An example of an agitator like the present device is illustrated in the A. C. Carter Patent No. 2,452,730, issued November 2, 1948. The shell 8 has a one-piece hollow body molded from a suitable opaque, plastic material and is provided with a circular hole 9 through which the chamber 7 is entered into the shell for connection therewith. The chamber 7 is constructed from

2

a clear, transparent plastic material and comprises a cylindrical side wall 10, open at one end 11 and closed at its opposed end by a transverse, planar window 12 which is formed integral with the side wall and disposed about flush with the opening 9 in the shell. The side wall 10 may have an outwardly projecting, continuous circular flange 13 formed integral therewith around the window 12 which overlaps and is adhesively secured to the marginal portion of the shell adjacent the opening 9 therein.

As best shown in FIG. 1 a buoyant die member 14 is immersed in an opaque liquid 15 which with the die completely fills the chamber 7, said chamber being sealed off by a suitable closure 16 that is secured across its open end 11. Normally when the agitator is inoperative it rests upon a suitable supporting surface 17 (FIG. 1) in which position the buoyant die member 14 will be borne upwardly by the liquid 15 against the inner surface of the closure 16. When the agitator is turned end-for-end the window 12 will move from the downwardly facing position shown in FIG. 1 to an upwardly facing position depicted in FIGS. 2 and 3 of the drawing, such inversion moving and rotating the buoyant die member from the position shown in FIG. 1 to an opposite position in engagement with the inside surface of the transparent window 12.

Now with reference to FIGS. 3 and 4 of the drawing it will be seen that the buoyant member 14 has a generally round shape and is provided with a plurality of marginally inter-connected, flat exterior facets 17. In the buoyant die member depicted in the drawings each facet 17 has a planar, triangular shape in plan and has a set of embossed indicia 18 made integral with the body of the member and raised a uniform height upon and projected outwardly from the plane of each facet. This buoyant die member is constructed from any well known and appropriate plastic material that has a density slightly lighter than the density of the fluid 15 in the container 10 to provide the desired operating buoyancy for the member.

The die member may have a solid body in which eventually the member and the raised sets of indicia integral on its facets would be made by the conventional split mold process. Preferably, as shown in the drawings, the die member will be hollow to effect economies in manufacture, and will then be produced by the compression molding process wherein a flat thermo-plastic strip is cut and indicia pressed therein, the strip being folded and the ends secured together to form the finished hollow member shown in the drawings. As the body of the die member and the sets of raised indicia on the facets have a one-piece plastic body the buoyant member will simply have one overall solid color, such color being preferably white for the purpose to be presently set forth. The body of the buoyant die member is provided with a number of holes 19 to permit filling of the member with liquid to thus give the desired buoyant effect to the die member.

As has been specified the fluid 15 in the container is opaque in nature and is preferably black in color. Thus the overall color of the die and the color of the liquid are greatly contrasted and with reference to FIGS. 2 and 3 it will be noted that when the raised set of indicia 18 on one facet of the buoyant die member come into contact with the inside face of the window 12 the clear and distinct outline of the set of indicia will be observed therethrough but the indicia carrying facet 17 cannot be observed because the raised set of indicia will hold said facet in spaced relation from the inside window surface and the intervening, opaque fluid between said window surface and the facet will conceal the image of the facet from view. Further the contrasting colors of the indicia and the opaque liquid will greatly enhance and make a very distinct image of the indicia beneath the window.

Because of the small difference in the specific gravities



of the die member and the liquid the flat facets of the buoyant members of heretofore constructed agitators had a tendency to adhere to the planar, inside surfaces of the window 12 or the opposed closure 16, depending upon the position of the agitator. Furthermore this adhering tendency became quite strong under sub-normal temperatures which increased the viscosity of the fluid, and there was therefore a noticeable degree of sluggishness in the movement of the buoyant die member from one end of the container to the other. The utilization of the raised set of indicia on each facet of the buoyant die member has altogether remedied this drawback in that only the relatively small uppermost areas along the tops of the sets of indicia contact the window or the closure and the total area being relatively small all tendency of the member to adhere to the closure or window has been eliminated.

With particular reference to FIG. 4 it will be seen that a set of indicia 18 has a marginally disposed alignment lug or boss 20 formed integral with the body of the buoyant die member 14 which projects outwardly from the face thereof and has its outer terminal end lying in the common plane of the outer faces of said set of indicia. As illustrated in FIGS. 1 and 4 of the drawing the indicia carrying facets 17 are angularly shaped in plan and, where required, each facet 17 has a corner disposed lug or boss 20 projecting upwardly therefrom to the same height as the plane of raised set of indicia thereon. These bosses are devised to guide and then hold the proper facet in parallelism beneath the window 12 to thereby overcome any tendency of the facet to lodge in an inclined position under the window which would otherwise prevent clear sighting of the set of indicia thereunder. It is thought that the bosses could be very small in section so that they could not be observed beneath the window.

Having thus described my invention, what I claim as new is:

1. In a liquid filled die agitator the combination of a closed chamber having a side wall, an end wall and an opposed transparent end wall forming a window for the chamber, an opaque liquid filling the chamber, a substantially round, buoyant die member made of a plastic material immersed in the liquid, said die member having a plurality of marginally inter-connected flat facets on the exterior thereof, and a set of raised indicia molded on and projecting a uniform distance from each facet, the overall color of the die member contrasting with the color of the opaque liquid, whereby in operative die position, the uppermost surfaces of a set of indicia on one facet will engage the inside face of the window and the upper surface of said facet will be maintained in spaced relation to said inside face of the window by the set of indicia.

2. In a liquid filled die agitator the combination of a closed chamber having a side wall, an end wall and an opposed transparent end wall forming a window for the chamber, an opaque liquid filling the chamber, a substantially round, thin walled and hollow buoyant die mem-

ber made of thermo-plastic material immersed in the liquid, said die member having a plurality of marginally inter-connected flat facets on the exterior thereof, and a set of raised indicia on and projecting from each facet, the overall color of the die member contrasting with the color of the opaque liquid, whereby in operative die position the uppermost surfaces of a set of indicia on one facet will engage the inside face of the window and the upper surface of said facet will be maintained in spaced relation to said inside face of the window by the set of indicia.

3. In a liquid filled die agitator the combination of a closed chamber having a side wall, an end wall and an opposed transparent end wall forming a window for the chamber, an opaque liquid filling the chamber, a substantially round, buoyant die member made of plastic material immersed in the liquid, said die member having a plurality of raised sets of indicia projecting from the exterior face thereof, and a raised boss adjacent to a set of indicia and projecting from the face to the same height as said set of indicia, the overall color of the die contrasting with the color of the opaque liquid whereby in operative die position the uppermost surfaces of the set of indicia and the adjacent boss will engage the inside face of the window, the face of said buoyant member being maintained in spaced relation to said inside face of the window by the boss and the set of indicia.

4. In a liquid filled die agitator the combination of a closed chamber having a side wall, an end wall and an opposed transparent end wall forming a window for the chamber, an opaque liquid filling the chamber, a substantially round, thin walled, perforate and hollow buoyant die member made of a thermo-plastic material immersed in the liquid, said die member having a plurality of triangularly shaped and marginally inter-connected flat facets on the exterior thereof, a raised set of indicia of uniform height on and projecting from each facet, and a raised boss on and projecting from a corner of each facet and having the same uniform height as the set of indicia thereon, the overall color of the die contrasting with the color of the opaque liquid whereby in operative die position the uppermost surfaces of the set of indicia and the corner located boss on a facet will engage the inside face of the window, the upper surface of said facet being maintained in spaced relation to said inside face of the window by the boss and the set of indicia.

#### References Cited in the file of this patent

##### UNITED STATES PATENTS

50	1,586,429	Kiesling -----	May 25, 1925
	1,974,782	Muench -----	Sept. 25, 1934
	1,986,710	Brown -----	Jan. 1, 1935
	2,452,730	Carter -----	Nov. 2, 1948

##### FOREIGN PATENTS

55	363,329	Great Britain -----	1932
	1,162,423	France -----	Apr. 8, 1958