

Aug. 8, 1961

W. H. BUSSEY

2,995,642

INDUCTION HEATING APPARATUS

Filed June 4, 1959

2 Sheets-Sheet 1

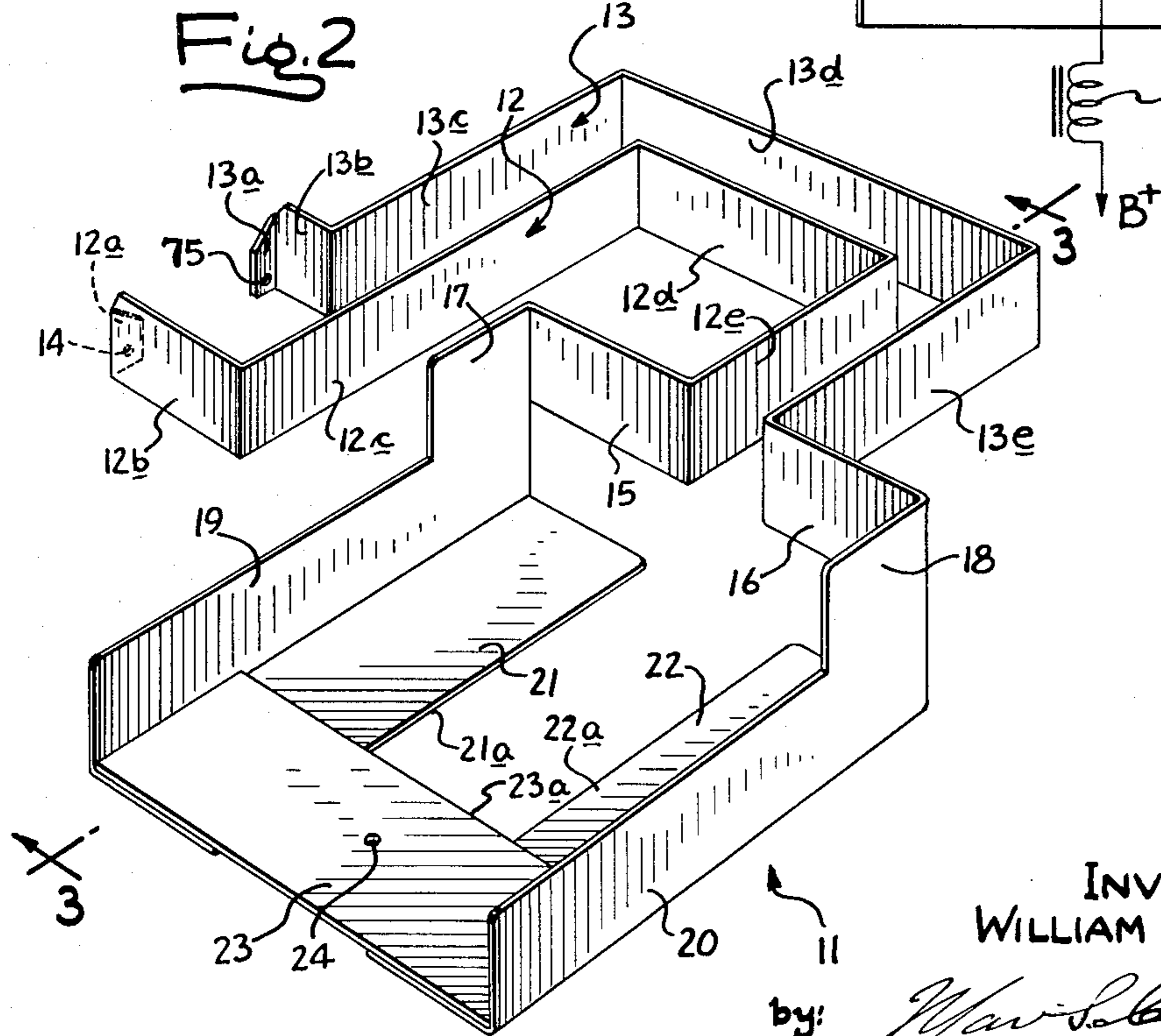
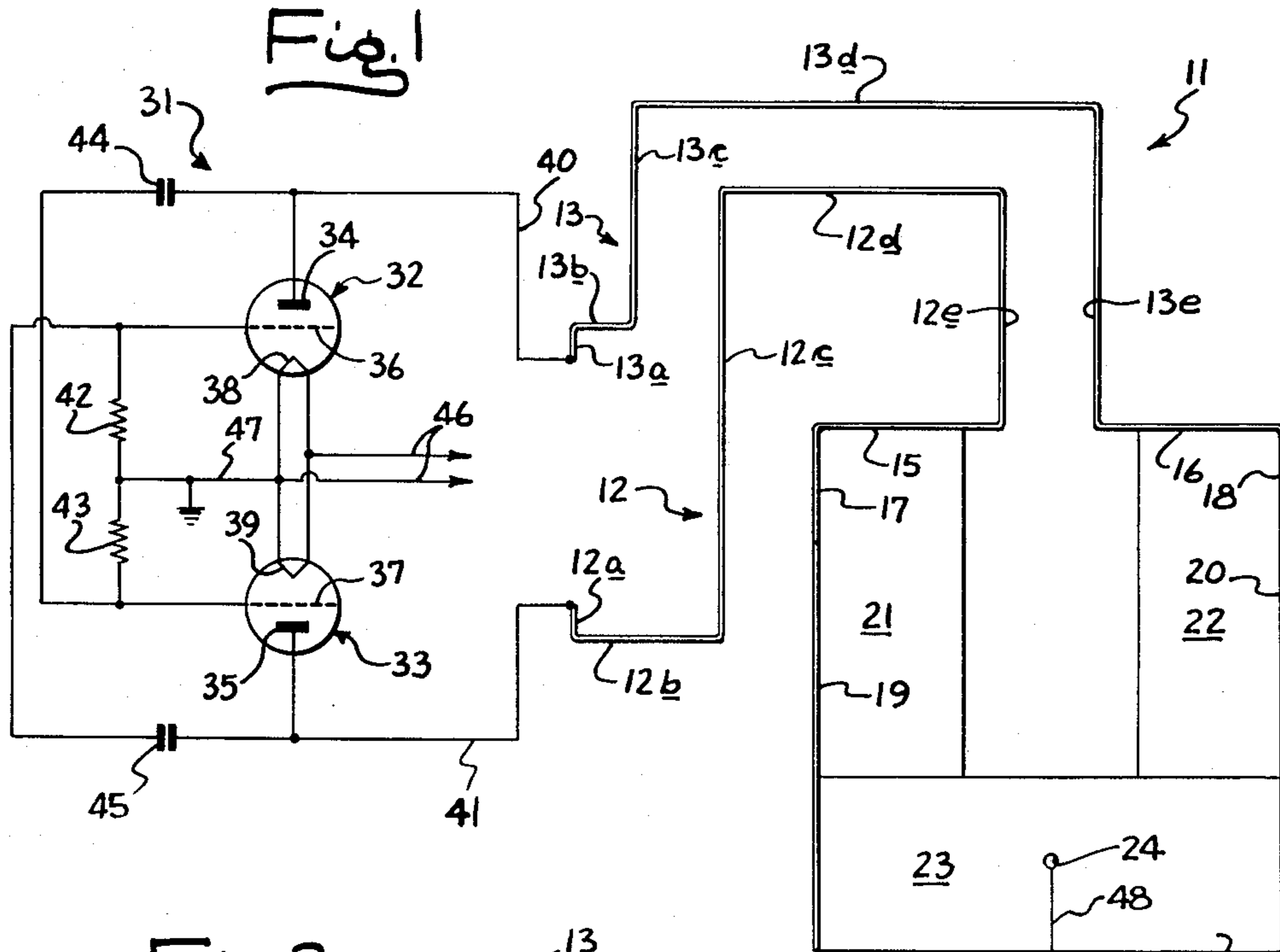

INVENTOR
WILLIAM H. BUSSEY

by:

W. S. Bayne
ATTY.

Aug. 8, 1961

W. H. BUSSEY

2,995,642

INDUCTION HEATING APPARATUS

Filed June 4, 1959

2 Sheets-Sheet 2

Fig. 3

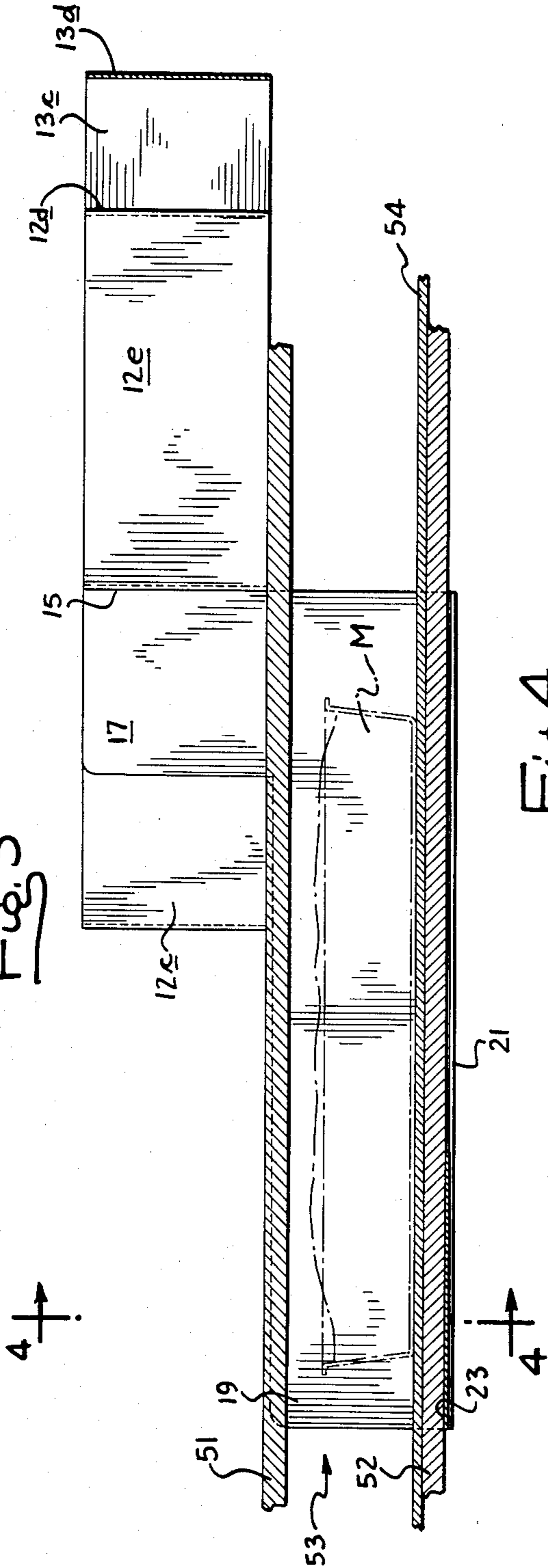
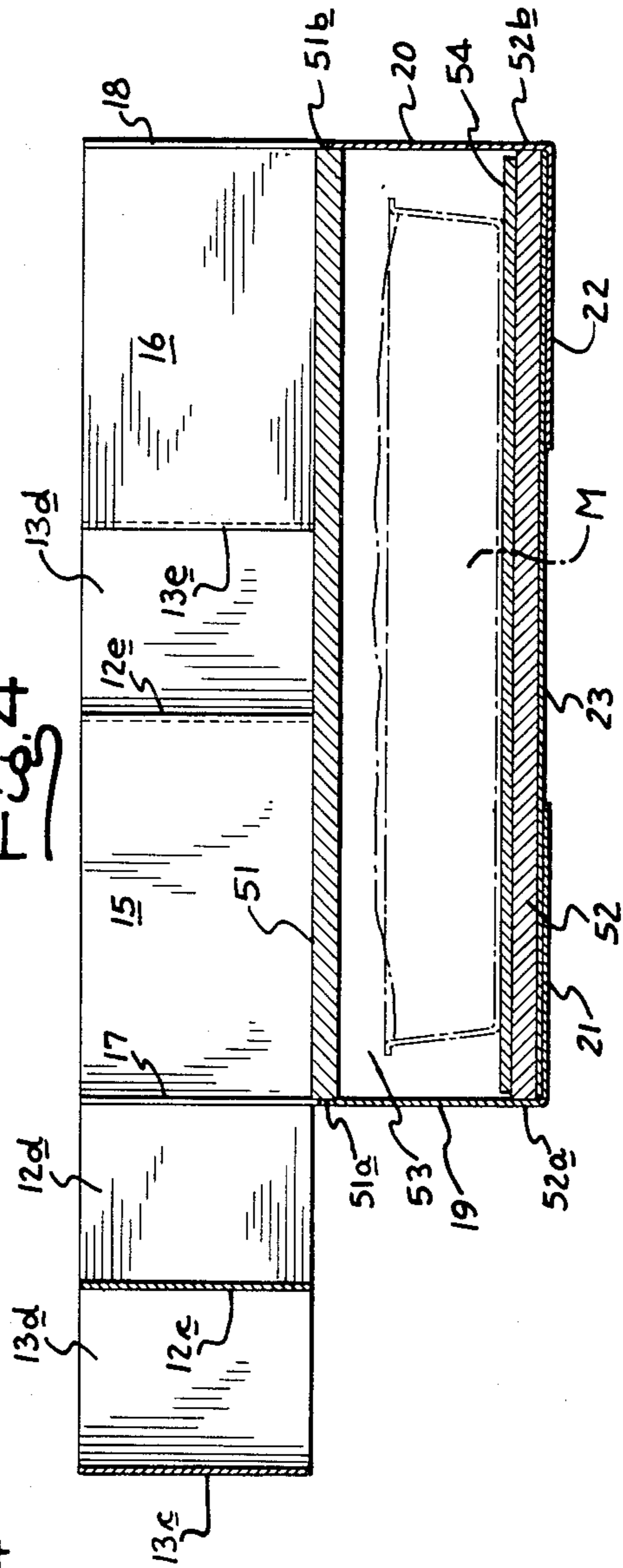

Fig. 4



INVENTOR
WILLIAM H. BUSSEY

by: *Harold Payne*
ATTY.

1

2,995,642

INDUCTION HEATING APPARATUS

William H. Bussey, Rockford, Ill., assignor to Stoner Investments Inc., a corporation of Illinois

Filed June 4, 1959, Ser. No. 818,122

5 Claims. (Cl. 219-10.69)

This invention relates to an induction heating apparatus and, more particularly, to a novel electronic heating coil in the form of a compact folded quarter-wave transmission line having a lumped inductance load termination for generating the magnetic flux.

Electronic heating by induction is well known in the prior art. A coil is supplied with high frequency alternating current by means of a conventional oscillator circuit. The alternating current flowing through the coil generates an alternating magnetic field in which the object to be heated is placed. The alternating magnetic field induces alternating currents in the object which, of course, must be somewhat conductive, and the induced currents flowing in the object produce the desired heating effect.

Such heating coils, as heretofore employed in the prior art, were usually of spiral or rectangular configuration and were connected directly to the oscillator circuit so as to constitute a conventional inductive load for the latter. This prior art arrangement, while satisfactory for some applications where the heating time and the initial cost of the apparatus were not of vital importance, is nevertheless inadequate for other applications where such factors are vital. For example, in automatic vending machines which dispense hot sandwiches, meals, and other foods, it is necessary that the merchandise be heated from the refrigerated temperature (at which it is stored to prevent spoilage) to the desired temperature within a very short time. Furthermore, the heating apparatus for an automatic vending machine cannot be too complex or expensive in order that the cost of the machine may not be prohibitive. For an oscillator circuit of a given power output, the rapidity with which an object can be inductively heated is dependent upon the efficiency with which the coil converts the oscillator power output into current-inducing magnetic flux. Heretofore, the available inexpensively constructed inductive heating arrangements were not efficiency enough to satisfy the requirements as to heating time, while those which did heat rapidly were prohibitively expensive.

The present invention solves these problems by a novel heating arrangement in the compact form of a folded quarter-wave transmission line having substantially uniformly distributed parameters therealong and a load termination in the form of a single conductive loop for generating the magnetic field in response to the current flow therethrough. Because the equivalent electrical length of the line is a quarter of the wave length of the alternating current supplied thereto by the oscillator circuit, the current will be a maximum at the termination of the line, whereby the magnetic field will also be a maximum to provide the ultimate induced current in the food or other product for a given power rating of the oscillator.

By the use of a heating arrangement comprising a compact folded transmission line, the present invention provides a higher "Q" than the prior art devices; that is, for a given oscillator circuit, less of the energy generated thereby is dissipated as a power loss.

Another novel feature of the present invention resides in the particular construction of the loop or single-turn coil constituting the load termination of the transmission line, whereby an optimum number of ampere-turns are so located with respect to the food or other product as to provide a field producing the maximum induced cur-

2

rent in the food for any given oscillator output. This load termination loop comprises thin wide planar conductive elements formed of sheet copper and lying in a horizontal plane parallel to and closely adjacent the plane of the food or other product to be heated. The resultant upwardly extending electromagnetic field diverges outwardly as it rises through the food so that the diffused part of the field goes through the periphery of the food or other product and is not wasted.

The conductive elements are preferably provided with vertical flanges which dissipate heat by radiation and conduction. This, together with the heat dissipation provided by the large surface to volume ratio of the sheet-like conductive elements, eliminates the necessity of forced air cooling. The vertical flanges also serve the additional important functions of preventing the electromagnetic field from leaking horizontally below the plane of the food or other product and for rigidifying the coil structure.

Another novel feature of the present invention is the arrangement whereby the entire transmission line including the load termination constituting the flux generating loop or coil may be economically formed of one or a few integral metal sheet strips.

Other advantages and novel features of the present invention are inherent in the structure described and claimed below or will become apparent to those skilled in the art from the following detailed description in connection with the accompanying drawings wherein:

FIG. 1 is a schematic view showing a conventional push-pull oscillator circuit connected to the novel transmission line arrangement constituting the present invention;

FIG. 2 is a perspective view showing the transmission line with the flux generating single-loop coil constituting the load termination thereof;

FIG. 3 is a longitudinal sectional view taken substantially on line 3-3 in FIG. 2 and showing the single-loop coil in combination with insulating sheets and a conveyor belt for carrying a packaged meal through the field of the coil so as to illustrate how the invention may be employed in an automatic vending machine for vending hot packaged meals; and

FIG. 4 is a vertical transverse sectional view taken substantially on line 4-4 of FIG. 3.

Referring first to FIG. 2, reference numeral 11 indicates generally a quarter wave transmission line having a flux generating single-loop coil as the load termination thereof. Line 11 comprises a pair of longitudinal mutually-parallel planar conductive portions 12, 13 which lie in vertical planes and extend in a folded configuration in a horizontal plane. The line portions 12, 13 comprise input terminal portions 12a, 13a having apertures at 14, 15, respectively, for electrical connection to the plates of a push-pull oscillator circuit as will be described in more detail below. Terminal portions 12a, 13a are formed integral with and extend perpendicular to line portions 12b, 13b, respectively, which are mutually spaced and parallel to each other. Line portions 12c, 13c extend perpendicular to portions 12b, 13b, respectively, and lead to parallel line portions 12d, 13d which extend perpendicular to portions 12c, 13c. Portions 12d, 13d in turn lead to parallel line portions 12e, 13e extending perpendicular thereto.

Formed integral with line portions 12e, 13e are a pair of oppositely extending connecting portions 15, 16 each in turn formed integral with an edge of a respective upwardly extending portion 17, 18 of vertical flange portions 19, 20. The latter extend along and are formed integral with the outer longitudinal edges of a pair of parallel longitudinal mutually-spaced planar conductive ele-

ments 21, 22 which lie in a common horizontal plane. A transverse planar conductive element 23 has its opposite ends secured to the respective ends of elements 21, 22 as by soldering. The transverse element 23 is provided with an aperture 24 for connection to the B+ plate supply voltage.

The entire transmission line 11 is preferably stamped or otherwise formed of sheet copper, and is silver plated in order to prevent the formation of copper oxide which would increase the resistivity of the line and thereby lower the "Q." Portions 12, 15, 17, 19 and 21 may be formed of a single integral sheet, as may also portions 13, 16, 18, 20 and 22. If desired, the transverse portion 23 may be integral with the portions 21 and/or 22 so that the entire line 11 may be stamped or cut from a single integral sheet.

Referring now to FIG. 1, there is shown schematically a push-pull oscillator circuit indicated generally by the reference numeral 31 and comprising a pair of triode vacuum tubes 32, 33 having plates 34, 35, grids 36, 37, and directly heated cathodes 38, 39 respectively.

A lead 40 secured within aperture 75 connects plate 34 with portion 13 of the transmission line 11, and a lead 41 similarly connects the other plate 35 with line portion 12. Grids 36, 37 are respectively connected to grid leak resistors 42, 43 which have their other ends connected to ground. A capacitor 44 is connected between the plate 34 of one tube 32 and the grid 37 of the other tube 33. In a similar manner, another capacitor 45 is connected between the plate 35 of the second tube 33 and the grid 36 of the first tube 32.

The leads 46 extend from the cathodes 38, 39 to a conventional heater supply (not shown) for heating the cathodes 38, 39. One side of the cathode heater supply may be grounded by the lead 47. A lead 48 has one end secured within aperture 24 of transverse portion 23 and its opposite end is connected to a choke 49 which is in turn connected to the B+ plate supply voltage.

Referring now to FIGS. 3 and 4, the reference numerals 51, 52 indicate a pair of horizontal planar insulating sheets formed of boro-silicate glass and powdered mica such as manufactured by the General Electric Company under the trademark "Mycalex," or by Mykroy, Inc. under the trademark "Mykroy." Sheet members 51, 52 have respective longitudinal edges 51a, 52a in abutment with or closely adjacent to vertical flange 19, and their opposite longitudinal edges 51b, 52b are similarly disposed with respect to the other flange 20. The lower sheet member 52 rests upon conductive elements 21, 22, 23. The upper sheet member 51 is arranged a predetermined height above the lower sheet member 52 so as to form therebetween a channel or passageway 53 through which may pass the product to be heated by the apparatus, which may be, for example, a frozen packaged meal shown in dash-dot lines and indicated by the reference letter "M" and of a type suitable for dispensing by an automatic vending machine.

The meal package "M" may be in the form of a conventional container of plastic, paper or other non-conductive material and is refrigerated while in storage in the vending machine. However, it is to be understood that other types of products may be heated by the subject invention which is not limited in its application to food heating or to the vending machine field. In order to carry the meal package "M" through the channel 53, there is provided a continuous conveyor belt 54 formed of cloth or polyethylene and which has a run portion riding along the upper surface of the lower sheet member 52. Continuous belt 54 is entrained in the usual manner around a pair of pulleys (not shown) and travels in a direction from left to right as viewed in FIG. 3.

The oscillator circuit 31 generates a high-frequency alternating voltage, preferably in the range of about 20 to 55 megacycles, which is imposed across the input terminals 12a, 13a of transmission line 11. As previously noted

the transmission line comprises line portions 12, 13 and a load termination or "end" of the line consisting of elements 21, 22, 23 and flange portions 19, 20. This load termination is in effect an enlarged rectangular loop and may be considered as a one-turn coil. The line portions 12, 13 are so constructed and oriented as to have substantially uniformly distributed parameters of inductance, capacitance and resistance, insofar as may be practically attainable in view of the folded construction, except at the input end where there is a lumped capacitance due to the effective anode capacitance of tubes 32, 33 and except at the load termination "end" of the line where the enlarged rectangular loop constitutes a lumped inductance.

The line 11 has an equivalent electrical length equal to one-quarter of the wave length of the oscillator frequency. As a result, the current at the electrical end of the line will be at a maximum for any given power rating of the oscillator circuit 31. That is, the alternating current flowing through the rectangular loop formed by elements 19, 20, 21, 22, 23 will be at a maximum and hence the magnetic flux generated by the loop will also be at a maximum. At the same time, the alternating voltage in the loop will be at a minimum.

The transmission line arrangement of the present invention is superior to the conventional electronic heating coil in several respects. The line has a characteristically higher "Q" at the relatively high frequencies employed in electronic heating, and, as a result, less of the oscillator energy will be dissipated as a power loss. In addition, the construction of the rectangular loop forming the end of the line provides a maximum coupling of the generated flux to the food or other product to be heated. That is, a maximum number of ampere-turns are so located as to provide a field producing a maximum induced current in the food for a given oscillator output. Furthermore, the sheet metal construction of the line portions and rectangular loop provides for rapid heat dissipation by radiation and conduction due to the relatively large surface-volume ratio, and eliminates the necessity for expensive forced air cooling. The sheet metal construction is further advantageous in that it is economical to fabricate.

The field generated by the alternating current flowing through the rectangular loop extends vertically upward through the rectangular space formed by the inner edges 21a, 22a, 23a of the respective horizontal conductive elements 21, 22, 23. As the field extends upwardly, it also diverges outwardly whereby the diffused part or fringe of the field goes through the periphery of the food and is not wasted.

The vertical flanges 19, 20 prevent the field from leaking in a horizontal path below the food. That is, flanges 19, 20 tend to direct the field upwardly through the food so as to reduce the leakage flux. Flanges 19, 20 further function to dissipate heat by radiation and conduction and also increase the rigidity of the rectangular loop.

It is to be understood that the specific embodiment shown in the drawing and described above is merely illustrative of one of the many forms which the invention may take in practice and that many changes therein may be devised by those skilled in the art without departing from the scope of the invention as delineated in the appended claims which are to be construed as broadly as permitted by the prior art.

I claim:

1. An induction heating apparatus comprising an oscillator circuit, a transmission line having input terminals connected to said oscillator circuit and having a load termination comprising an induction coil for generating a magnetic field, and means for locating the object to be heated in the field of said coil, said coil comprising a plurality of relatively thin wide planar conductive elements connected to each other in end-to-end relation and lying substantially in a single plane, the flux lines of said coil field extending perpendicularly through said

5

plane, a pair of said conductive elements extending longitudinally parallel to each other and each having a vertical flange formed integral therewith along a respective outermost longitudinal edge thereof, said vertical flanges extending parallel to each other and forming a horizontal channel therebetween, said locating means comprising a conveyor belt having a portion extending horizontally through said channel and through said coil field.

2. An induction heating apparatus comprising an oscillator circuit, a transmission line having input terminals connected to said oscillator circuit and having a load termination comprising an induction coil for generating a magnetic field, and means for locating the object to be heated in the field of said coil, said coil comprising a pair of parallel longitudinal mutually spaced conductive elements lying in a horizontal plane, a third longitudinal planar conductive element lying substantially in said horizontal plane and extending transversely of said first recited pair of conductive elements, said third element having each of its ends in electrical contact with an end of a respective one of said first pair of elements, each of said first pair of elements having a vertical flange portion formed integral therewith along the longitudinal edge thereof farthest removed from the other of said pair of elements, said locating means comprising a conveyor belt having a run portion thereof extending longitudinally of said conductive elements between said flange portions thereof and in a second horizontal plane spaced parallel to and closely adjacent said first recited plane.

3. An induction heating apparatus comprising an oscillator circuit, a transmission line having input terminals connected to said oscillator circuit and having a load termination comprising an induction coil for generating a magnetic field, and means for locating the object to be heated in the field of said coil, said coil comprising a pair of parallel longitudinal mutually-spaced planar conductive elements lying in a horizontal plane, a third longitudinal planar conductive element lying substantially in said horizontal plane and extending transversely of said pair of conductive elements, said third conductive element

6

having each of its ends in electrical contact with a first end of a respective one of said pair of elements, each of said pair of elements having a vertical flange portion formed integral therewith along its longitudinal edge farthest removed from the other element of said pair, each of said flange portions having a vertical extension thereof located adjacent the other end of its respective conductive element, said transmission line having vertical planar connecting portions in electrical contact with and extending transversely of said flange portions, said connecting portions having horizontal lower edges, said locating means comprising a conveyor belt extending longitudinally of said conductive elements between said flange portions thereof and in a second horizontal plane immediately above said first recited plane and spaced a predetermined distance below said horizontal edges of said connecting portions so as to permit the conveyed objects to pass below the latter.

4. An induction heating apparatus as recited in claim 3 wherein said line comprises a pair of longitudinal mutually-parallel portions lying vertically and extending in a folded configuration lying in a horizontal plane, each of said line portions being in electrical contact with a respective one of said connecting portions.

5. An induction heating apparatus as recited in claim 4 wherein each of said line portions together with its respective connecting portion, flange portion and conductive element constitutes an integral unitary sheet of conductive material.

References Cited in the file of this patent

UNITED STATES PATENTS

2,456,611 Baker ----- Dec. 21, 1948
 2,842,650 Naylor et al. ----- July 8, 1958

FOREIGN PATENTS

809,759 Great Britain ----- Mar. 4, 1959
 1,023,535 Germany ----- Jan. 30, 1958