

Aug. 8, 1961

W. MORELLO, JR., ET AL

2,995,388

GRIPPING DEVICE

Filed April 3, 1959

2 Sheets-Sheet 1

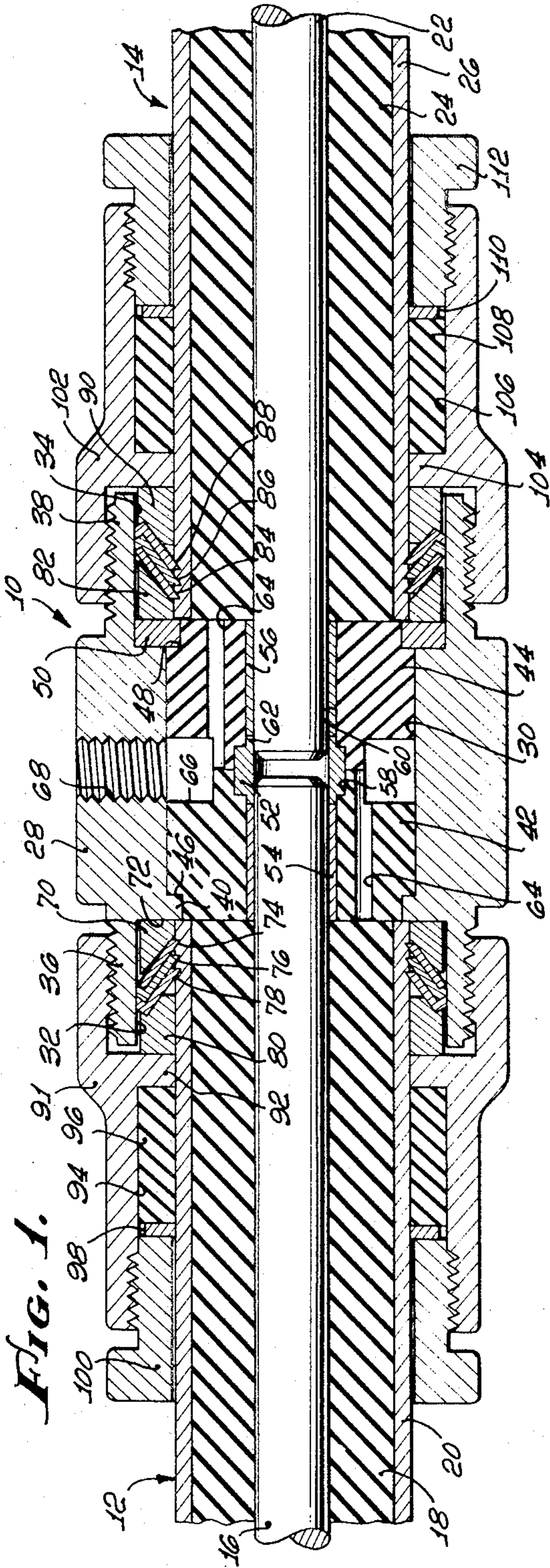

FIG. 1.

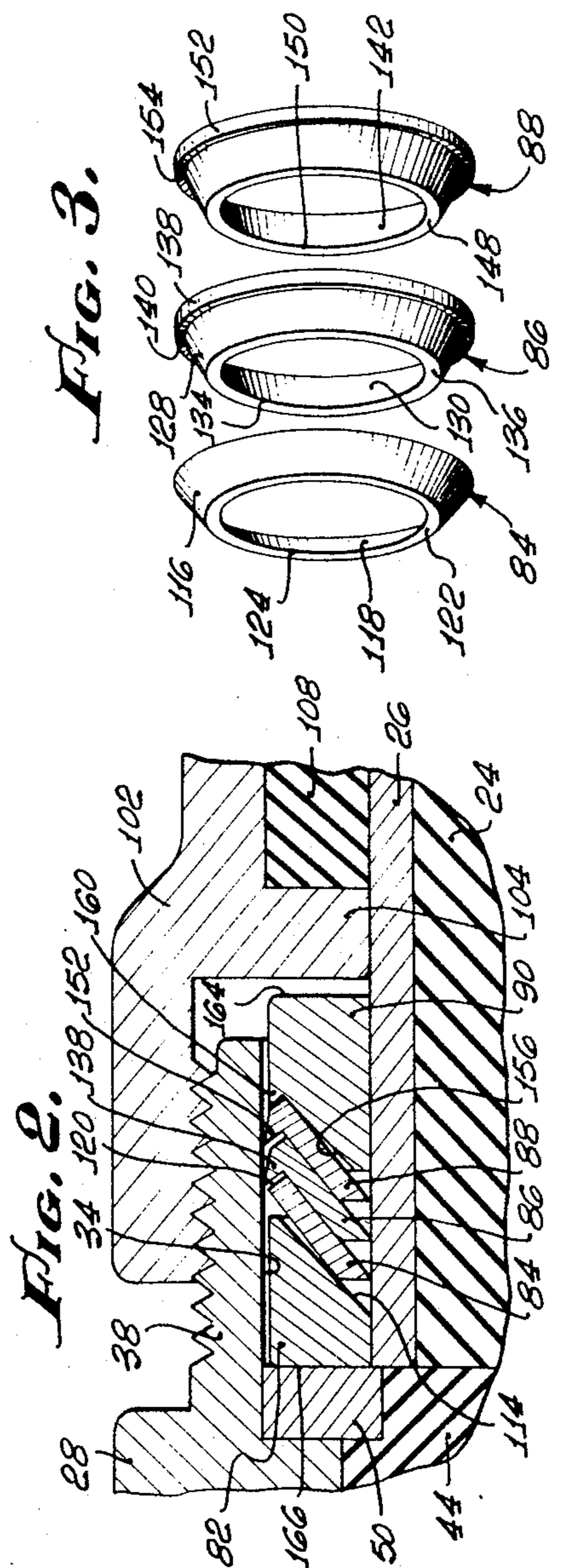

FIG. 3.

FIG. 2.

WILLIAM MORELLO, JR.
 WINTHROP E. JACKSON
 INVENTORS.

BY *Huebner & Worrel*
 ATTORNEYS.

Aug. 8, 1961

W. MORELLO, JR., ET AL

2,995,388

GRIPPING DEVICE

Filed April 3, 1959

2 Sheets-Sheet 2

Fig. 4.

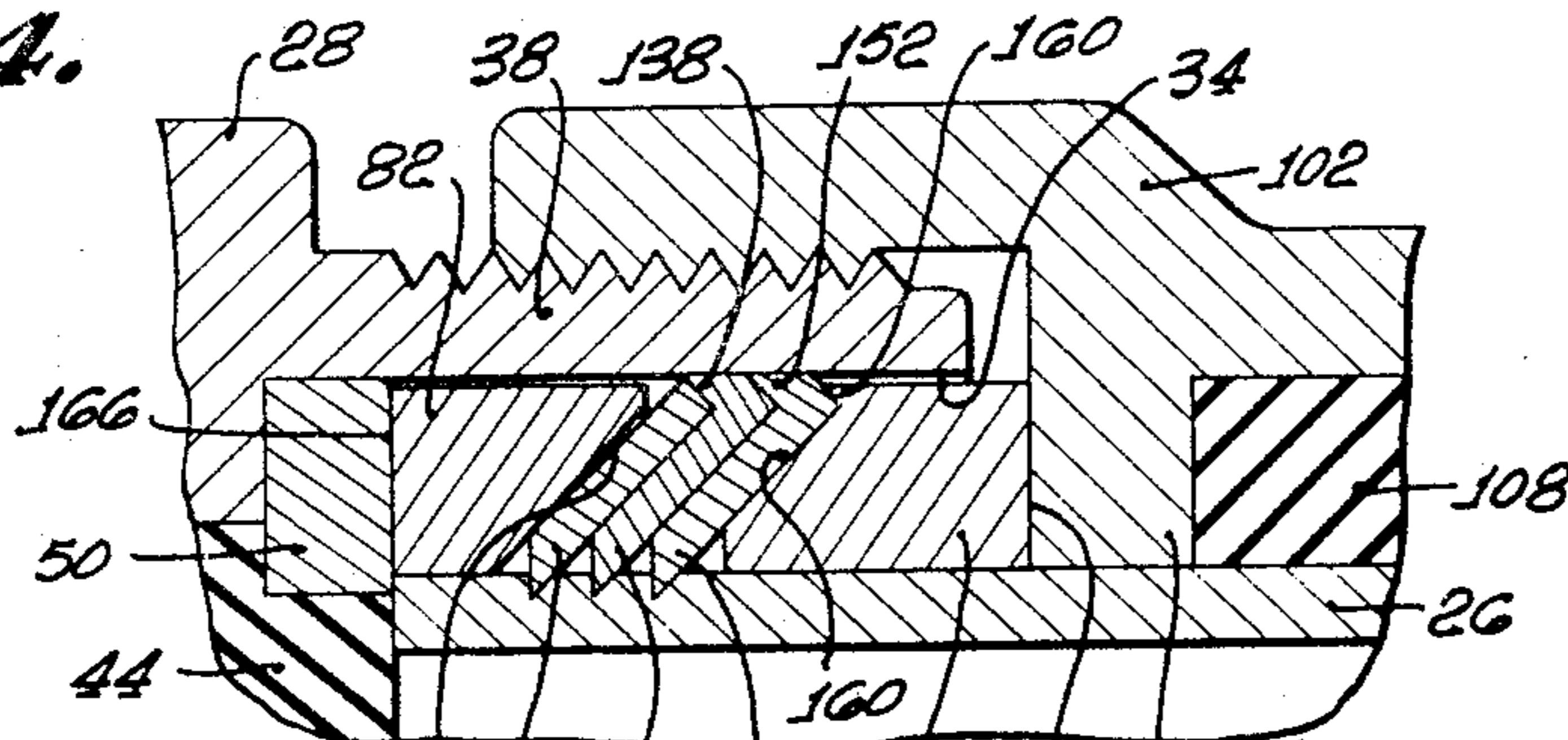

Fig. 5.

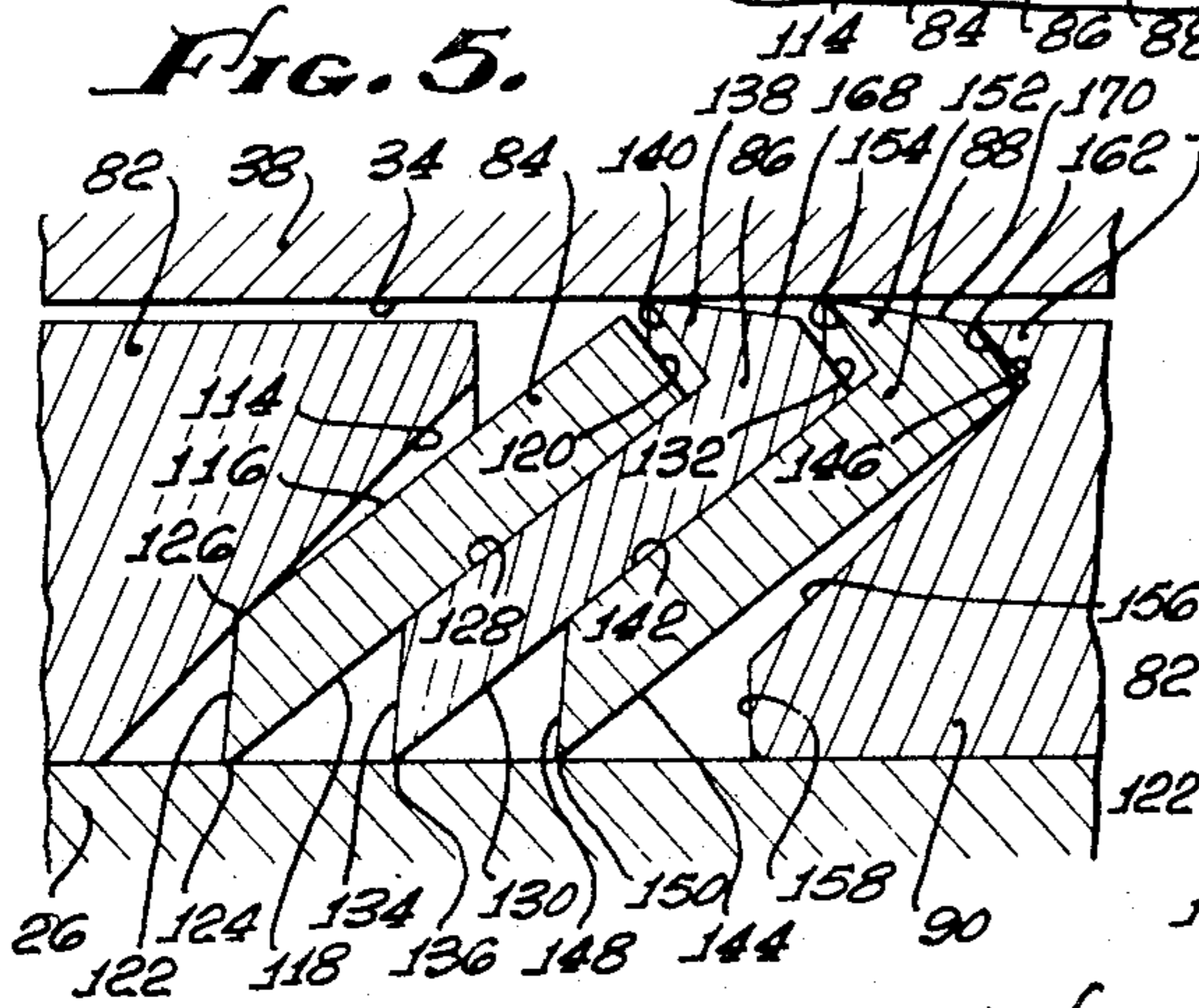

Fig. 6.

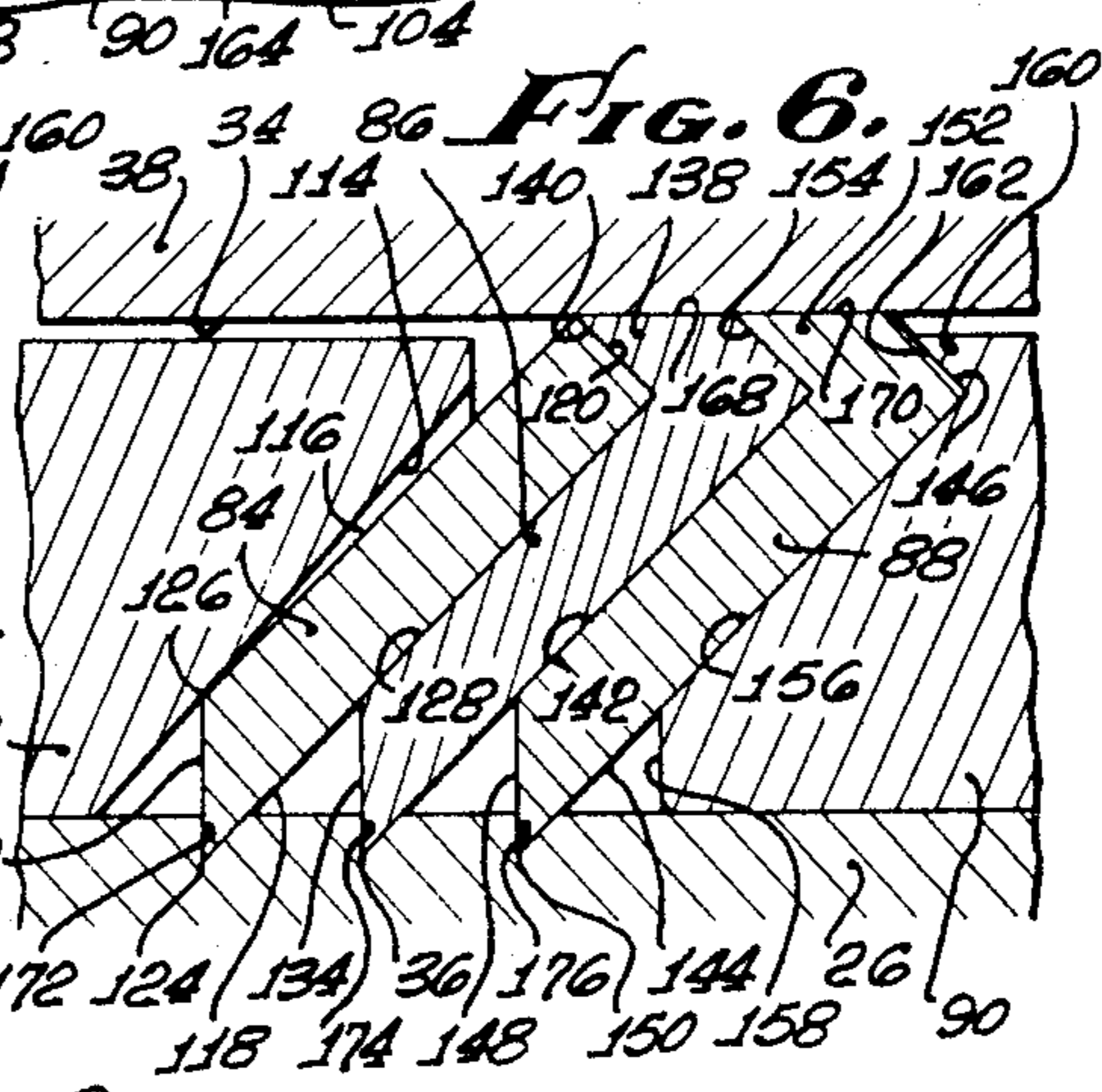

Fig. 8.

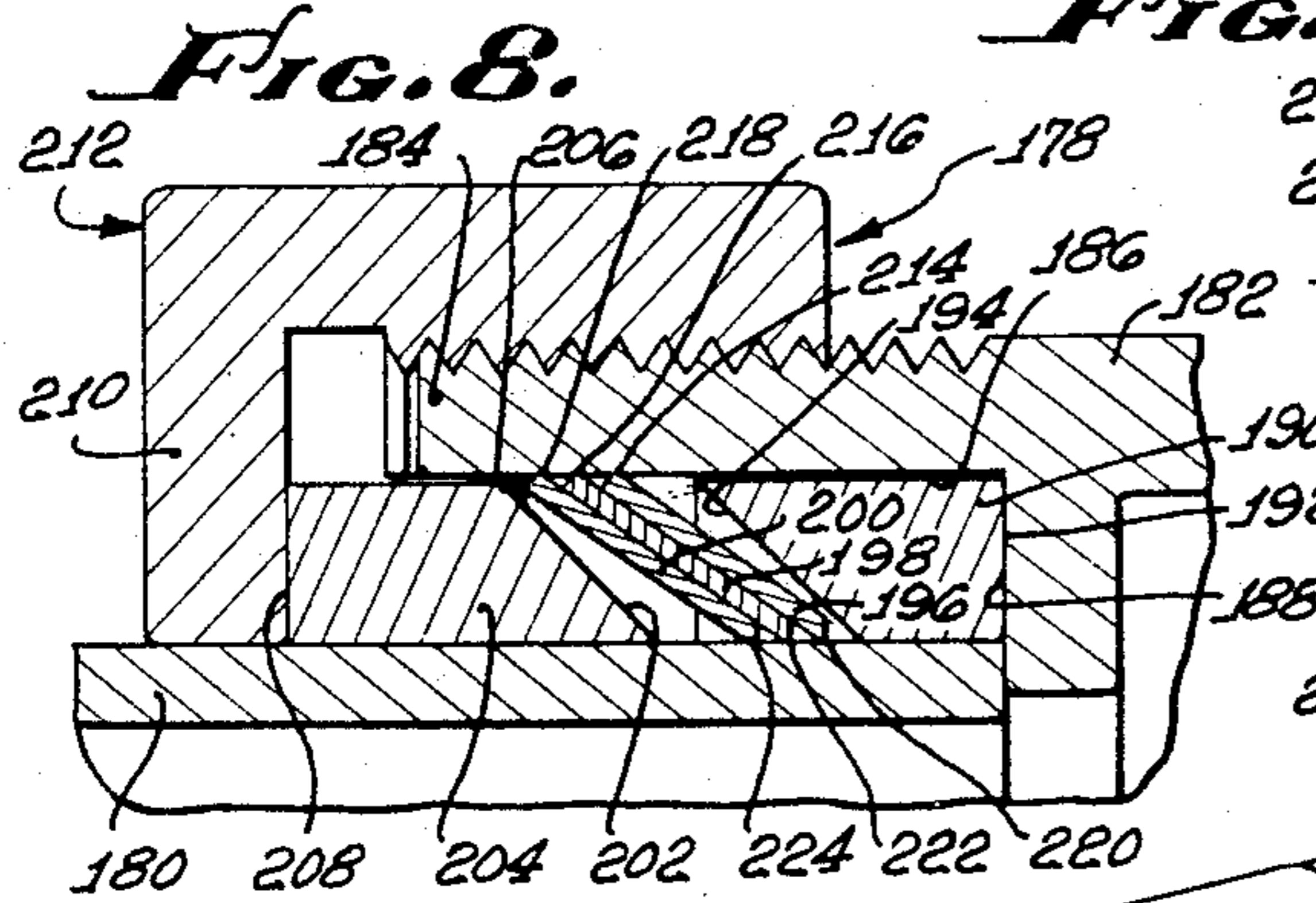

Fig. 9.

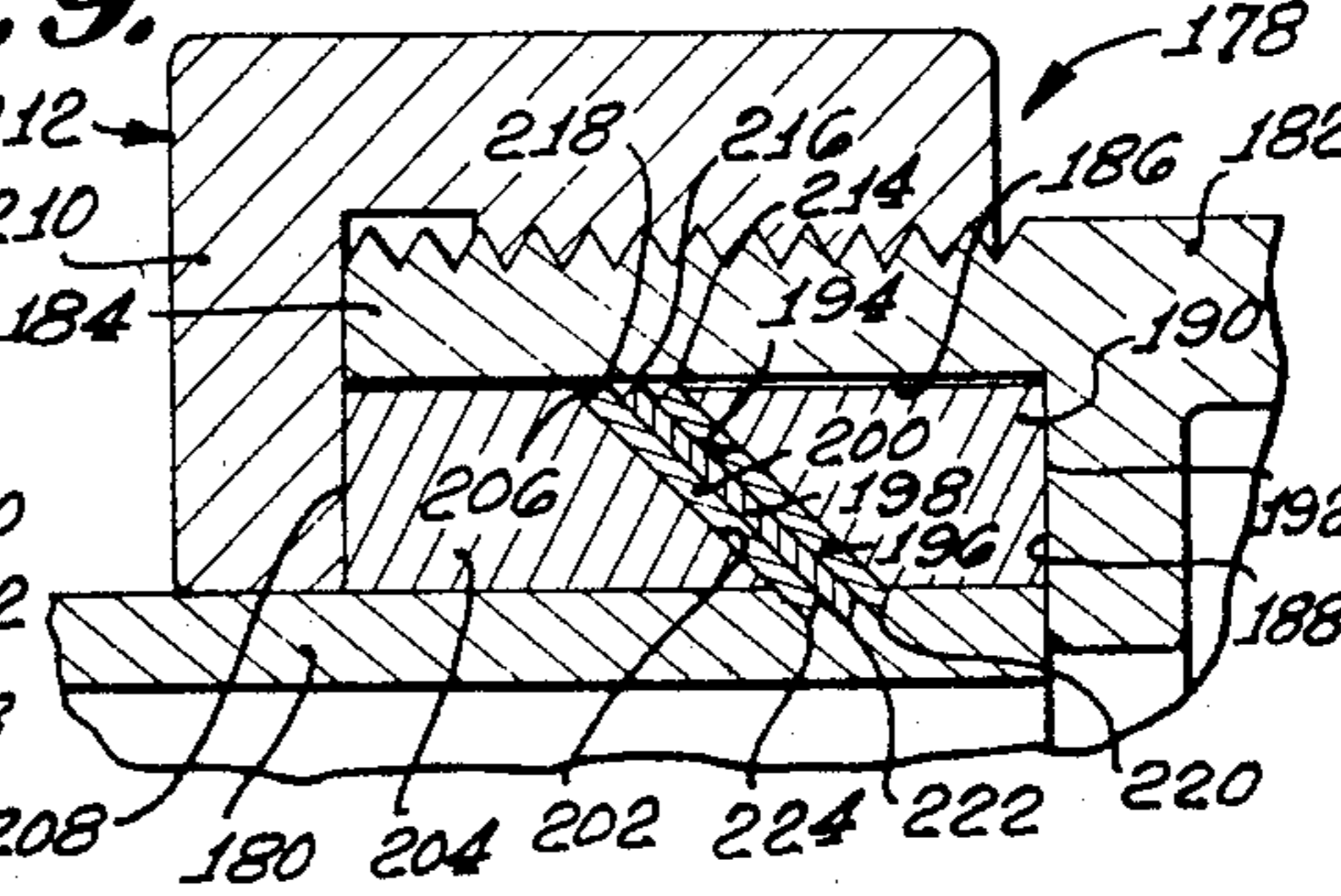
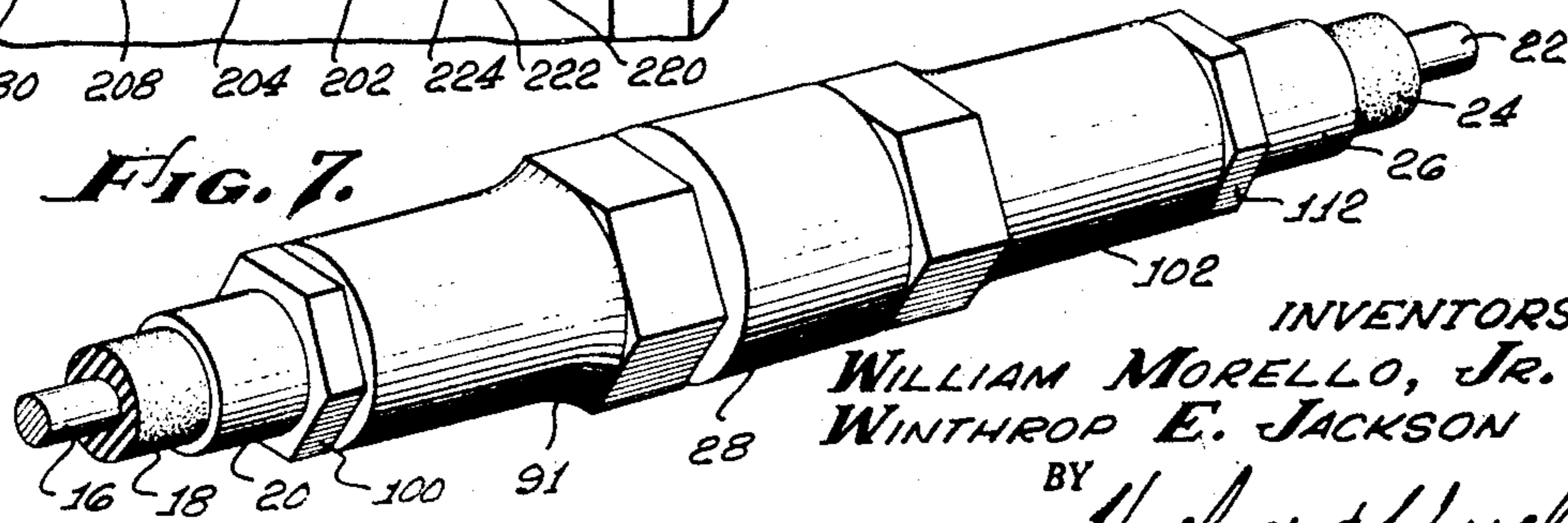

Fig. 7.



INVENTORS.
 WILLIAM MORELLO, JR.
 WINTHROP E. JACKSON
 BY
 Huebner & Worrel
 ATTORNEYS.

1

2,995,388

GRIPPING DEVICE

William Morello, Jr., Wakefield, Mass., and Winthrop E. Jackson, Winthrop, Maine, assignors to Cannon Electric Company, Los Angeles, Calif., a corporation of California

Filed Apr. 3, 1959, Ser. No. 803,852
3 Claims. (Cl. 285—340)

Our present invention relates to clamps for gripping elongated members such as cables and the like, and relates more particularly to clamping devices for attaching electrical connectors to electrical cables and tubular conducting members.

An object of our present invention is to provide means for gripping an elongated member which is capable of withstanding high axial loads while at the same time causing a minimum amount of distortion of the elongated member, whereby the gripping means is particularly useful for attaching an electrical cable or a tubular electrical conducting member to an electrical connector without causing sufficient distortion on the cable jacket or tubular transmission member to substantially adversely effect the electrical characteristics.

Another object of the present invention is to provide clamping means of the character described for attaching a jacketed electrical cable or tubular conducting member to a connector, the engaging means providing a positive grip against high axial loads without requiring the conventional flaring or similar forming of the cable jacket or tubular conducting member, and without injuriously distorting the cable jacket or tubular conducting member.

Another object of our invention is to provide a cable grip of the character described which, when embodied in an electrical connector to secure the end of a jacketed cable or tubular conductor within the connector, effects an efficient seal against the entrance of low viscosity fluid into the electrical field of the connector.

Another object of the present invention is to provide a gripping device of the character described which embodies an annular gripping means comprising a plurality of frusto-conical washers, hereinafter referred to as "conical washers" for convenience, which are nested within a collar about the cable or tubular conducting member to be gripped, the washers being axially compressed together between a pair of spaced actuating members or bushings within the collar, whereby the conical washers will be flattened sufficiently to reduce the inside diameter of the washers so that the inner edges of the washers grip the cable or conducting member, and to expand the outside diameter of the washers so that the outer edges of the washers grip the inner surface of the collar. An important aspect of the present invention resides in our novel guide shoulder means engaging the outer peripheral portions of one or more of the washers as the washers are constrained between the bushings, whereby the inner gripping edges of the washers will be caused to incise the cable or conducting member before the outer edges of the washers grip the inner surface of the collar. This novel guide shoulder action causes the washers to smoothly slide and contract into substantially uniform penetrating engagement with the cable jacket or tubular conductor, and also to finally grip the inner surface of the collar at the completion of the constraining movement of the bushings against the washers.

A further object of our present invention is to provide a clamping device of the character described which is simple and sturdy in construction, which requires no special tools for operatively engaging the clamp to an elongated member or disengaging the clamp from an elongated member, which has components that are re-usable, and which is not substantially adversely affected by me-

2

chanical vibrations or relatively large variations in temperature.

Further objects and advantages of this invention will appear during a course of the following part of this specification wherein the details of construction and mode of operation of a preferred embodiment are described with reference to the accompanying drawing, in which:

FIGURE 1 is a central longitudinal section through a connector embodying the present invention, the connector operatively connecting a pair of aligned cable ends;

FIGURE 2 is an enlarged, fragmentary longitudinal section similar to a portion of FIGURE 1, illustrating details of construction of a presently preferred embodiment of the cable grip in its unactuated position;

FIGURE 3 is an exploded perspective view illustrating the conical gripping washers embodied in the connector shown in FIGURES 1 and 2;

FIGURE 4 is an enlarged, fragmentary longitudinal section similar to FIGURE 2, but with the grip in the actuated position;

FIGURE 5 is a greatly enlarged, fragmentary section similar to FIGURE 2 showing the conical washers and engaging bushings in their unactuated positions;

FIGURE 6 is a greatly enlarged, fragmentary section similar to FIGURE 4, illustrating the conical washers and engaging bushings in their actuated positions;

FIGURE 7 is a perspective view of the electrical connector shown in FIGURE 1;

FIGURE 8 is a fragmentary central longitudinal section through a retaining device or connector for a radio frequency transmission tube, embodying a modified form of the present invention; and

FIGURE 9 is a fragmentary central longitudinal section through the retaining or connector device of FIGURE 8 showing the completed connection.

Referring to the drawings, and at first particularly to FIGURE 1 thereof, a cable connector 10 embodying one form of our new gripping means is shown in detail. The connector 10 provides an operative mechanical and electrical connection between the ends of a pair of cables 12 and 14. The cable 12 includes a center conductor 16, suitable insulation 18 surrounding the conductor 16, and a cable jacket 20 normally composed of aluminum or other suitable metal.

Although the present invention is shown in the accompanying drawings and will be described herein in detail in connection with the engagement of jacketed electrical cable or a tubular electrical conducting member in an electrical connector or retaining device, it is to be understood that the present invention is broader in scope and is applicable to the clamping of other elongated members for other purposes.

The cable 14, like cable 12, comprises a center conductor 22, surrounded by insulation 24 and a cable jacket 26.

The cable connector 10 includes a tubular body 28 having an axial bore 30. Counterbores 32 and 34 are provided in the opposed ends of tubular body 28, and define the inner walls of externally threaded annular skirts 36 and 38 at the respective ends of the tubular body 28.

A radially inwardly directed annular flange 40 is provided at the left-hand end of axial bore 30 in FIGURE 1, adjacent to the counterbore 32. A pair of annular insulation inserts 42 and 44, composed of any suitable insulating material such as Teflon, are disposed within the axial bore 30 of tubular body 28. The inserts 42 and 44 are introduced into tubular body 28 through right-hand counterbore 34, and the left-hand insulation insert 42 seats against the flange 40, being provided with an annular notch 46 that is complementary to flange 40.

The right-hand end of insulation insert 34 is provided

with a similar external notch 48 which receives an annular retainer ring 50.

Centrally disposed within the insulation inserts 42 and 44 is a conductor collar 52 which receives the ends of electrical conductors 16 and 22. Conductor sleeves 54 and 56 engage over the respective conductors 16 and 22, and abut against the opposite ends of the central conductor collar 52.

The conductor collar 52 seats within an annular groove 58 in the axial bore 60 through insulation inserts 42 and 44. Axially projecting lips 62 on conductor collar 52 seat within the bore 60, as do the conductor sleeves 54 and 56.

Axially disposed air bleed passages 64 are provided through insulation inserts 42 and 44, these passages 64 communicating with a central annular recess 66 in the outer walls of the insulation inserts 42 and 44. The annular recess 66 communicates with a radially disposed tapped bore 68 which is adapted to receive a pneumatic fitting (not shown) to allow the cables to be pressurized. Compressed air introduced through bore 68 passes into annular recess 66 and thence bleeds through passages 64 into the cable.

A bushing or actuating member 70, preferably composed of stainless steel is passivated and nonmagnetic, is disposed within the left-hand counterbore 32 of body 28, seating against shoulder 72 at the inner end of counterbore 32. Nested conical washers 74, 76 and 78 seat against the bushing 70. The washers 74, 76 and 78, which together comprise an annular gripping means, are preferably composed of a hard, yet resilient, metal. I have found conical washers composed of silver-plated beryllium copper to have these desired physical characteristics.

The washers 74, 76 and 78 are backed up by a second bushing 80, preferably composed of passivated and nonmagnetic stainless steel like the bushing 70.

In a similar manner, inner bushing or actuating member 82, the annular gripping means comprising conical washers 84, 86 and 88, and outer bushing 90 are disposed in the right-hand counterbore 34 of body 28, the inner bushing 82 seating against the annular ring 50. The right-hand bushings 82 and 90, and right-hand conical washers 84, 86 and 88, are identical in construction to the corresponding left-hand bushings 70 and 80, and left-hand conical washers 74, 76 and 78.

An internally threaded take-up sleeve 91 is threadedly engaged over the externally threaded left-hand skirt 36. Take-up sleeve 91 is provided with an internal flange 92 which operatively engages the left-hand edge of bushing 80 as sleeve 91 is threaded over skirt 36, to compress the conical washers 74, 76 and 78 between bushings 70 and 80, in order to flare the washers 74, 76 and 78 into gripping engagement with the cable jacket 20 and with the counterbore 32, in the manner hereinafter described in detail.

To the left of flange 92, the sleeve 91 is provided with a bore 94 within which an elastomer vibration damper sleeve 96 is seated. Washer 98 engages the outer or left-hand end of the sleeve 96, and is engaged by the inner end of an externally threaded tubular nut 100 which is threadedly engaged in the internally threaded end portion of sleeve 91. By tightening the tubular nut 100 the sleeve 96 will be compressed into engagement between the take-up sleeve 91 and the cable jacket 20.

Referring to the right-hand end of tubular body 28, an internally threaded take-up sleeve 102 is threadedly engaged over the externally threaded skirt 38, with radially inwardly projecting flange 104 of skirt 102 operatively engaging the bushing 90 to compress the conical washers 84, 86 and 88 together and to thereby flare these washers into gripping engagement with the cable jacket 26 and with the counterbore 34.

To the right of flange 104 the take-up sleeve 102 is provided with bore 106 within which elastomer vibration damper sleeve 108 is seated. Washer 110 engages the

right-hand end of sleeve 108, and is in turn engaged by the inner end of tubular nut 112 which is threadedly engaged in the right-hand end of bore 106. Sleeve 108 thus provides engagement between take-up sleeve 102 and cable jacket 26.

Referring now particularly to FIGURES 2, 3, 4, 5 and 6 of the drawings, we have there illustrated in detail the structure and operation of the right-hand conical washers 84, 86 and 88 and their related parts. This detailed description will also apply equally as well to the similarly constructed left-hand conical washers 74, 76 and 78 and their related parts.

The right-hand end of bushings 82 is provided with an annular inside conical face or tapering countersinks 114. The angle of face 114 relative to the axis of the connector is shown as being about 45 degrees, although this angle is not critical.

The innermost conical washer 84 seats within the inside conical face 114 of bushing 82. Washer 84 is provided with outer and inner conical surfaces 116 and 118, respectively, which are preferably parallel surfaces. In the unflared or unactuated position of washer 84 as shown in FIGURES 2 and 5, the angle of conical surfaces 116 and 118 relative to the longitudinal axis is somewhat smaller than the angle of the inside conical surface 114 of bushing 82. The angle of separation between inside conical face 114 and the adjacent outer conical surface 116 of washer 84 is not in any way critical; however, we have found that an angle in the neighborhood of about 10 degrees is usually sufficient to provide adequate clearance for the necessary flaring of washer 84.

The outer edge surface 120 of washer 84 is preferably, but not necessarily, disposed substantially at right angles to the outer and inner conical surfaces 116 and 118. The inner edge surface 122 of conical washer 84 is generally radially oriented relative to the axis of the connector. This provides a sharp innermost gripping corner 124 on the inner circumferential edge of the washer adapted to bite into and engage the cable jacket 26. It will thus be seen that the edge surface 122 comprises a bevel contiguous with the inner circumferential edge of the washer. The annular junction between inner edge surface 122 and outer conical surface 116 provides an outwardly facing fulcrum corner 126 which abuts against the inside conical face 114 of bushing 82.

The second conical washer 86 has an outer conical surface 128 disposed as substantially the same angle relative to the axis of the connector as the inner conical surface 118 of washer 84, whereby these surfaces will rest flush against one another when the washer 86 is nested within washer 84. The inner conical surface 130 of washer 86 is preferably parallel to the outer conical surface 128.

Outer edge surface 132 of washer 86 is preferably disposed at substantially right angles to the conical surfaces 128 and 130 in the same manner as the outer edge surface of the washer 84.

The inner edge surface 134 of washer 86 is generally radially disposed relative to the axis of the connector to provide the relatively sharp innermost gripping corner 136.

Washer 86 differs from washer 84 in that it is provided with a flange 138 at its outer end. The flange 138 extends over the outer edge of the innermost washer 84 when washers 86 and 84 are nested together. Flange 138 has an inwardly directed shoulder 140 disposed at substantially right angles to the outer conical surface 128 of washer 86, the outer edge surface 120 of washer 84 seating flush against this inwardly directed shoulder 140 when the washers are in their flared, actuated positions as shown in FIGURES 4 and 6.

The third conical washer 88 is substantially identical in construction to the second washer 86, being provided with parallel outer and inner conical surfaces 142 and

5

144, respectively, the outer conical surface 142 seating flush against the inner conical surface 130 of washer 86 when the washers are nested together. Washer 88 has an outer edge surface 146 disposed substantially at right angles to the conical surfaces 142 and 144, and has an inner edge surface 148 which is preferably generally radially disposed in order to provide a sharp innermost gripping corner 150. A flange 152 projects outwardly and to the left from outer conical surface 142, and has an inwardly directed shoulder 154 disposed substantially at right angles to the outer conical surface 142, whereby this inwardly directed shoulder 154 will operatively engage the outer edge surface 132 of the second washer 86 when the washers are in their flared, actuated positions as shown in FIGURES 4 and 6.

Referring now to bushing 90, this bushing is provided with an outside conical face 156 which is preferably disposed at a substantially greater angle relative to the axis than the opposed inwardly directed conical surface 144 of washer 88 when washer 88 is in the unflared or unactuated position as shown in FIGURES 2 and 5. The angle of outside conical face 156 relative to the axis is shown in FIGURES 2, 4, 5 and 6 as being slightly less than the angle of inside conical face 114 of bushing 82. These bushing faces 114 and 156 may, if desired, have the same angle relative to the axis. Outside conical face 156 terminates at its inner edge at generally radially disposed inner end wall 158.

Bushing 90 is also provided with a flange 160 which extends to the left over the outer edge 146 of the adjacent conical washer 88, this flange 160 having an inwardly directed shoulder 162 disposed preferably at substantially right angles to the outside conical face 156 of bushing 90. Thus, the inwardly directed shoulder 160 of bushing 90 engages against the complementary outer edge surface 146 of washer 88 when the washers are compressed axially together as shown in FIGURES 4 and 6.

In order to flare the washers 84, 86 and 88 from their undistorted, rest positions shown in FIGURES 2 and 5, so that the washers 84, 86 and 88 will grip the cable jacket 26 and engage against counterbore 34 as in FIGURES 4 and 6, all that is required is to rotate the take-up sleeve 102 on its threaded mounting so that it moves to the left. The flange 104 on take-up sleeve 102 operatively engages the outer end wall 164 of bushing 90 to move bushing 90 to the left. The inner bushing 82 is held against inward movement by abutment of its inner end wall 166 against the annular ring 50, so that this movement of the outer bushing 90 to the left will axially compress the conical washers 84, 86 and 88 between the bushings 90 and 82.

When the conical washers 84, 86 and 88 are thus constrained between bushings 90 and 82, they will all flare substantially a uniform amount as shown in FIGURES 4 and 6, so that their inner gripping corners 124, 136 and 150 will be reduced substantially equally in diameter to provide substantially equal penetrations into the cable jacket 26. Similarly, the outside diameters of conical washers 84, 86 and 88 will expand outwardly substantially equally, so that the outer peripheral surfaces 168 and 170 of the respective washer flanges 138 and 152, and also the outer peripheral corner 172 of washer 84, will engage the counterbore 34.

Referring now particularly to FIGURES 5 and 6 of the drawings, when bushing 90 is moved toward bushing 82 in order to actuate the gripping device, the bushing 90 engages and exerts a force on washer 88 near the outer edge of washer 88. The inside conical face 114 of bushing 82 exerts a generally oppositely directed force against the fulcrum corner 126 of washer 84, this force being directed substantially vertically to the face 114 of bushing 82. Thus, a force couple is provided which urges the washers 84, 86 and 88 anti-clockwise as pictured in axial section in FIGURES 5 and 6, or toward a more flattened condition.

6

However, while bushing 90 is moving to the left to compress the washers between the bushings, the inwardly facing shoulder 162 on bushing flange 160 engages the outer edge surface 146 of washer 88 to apply sufficient axial force to the peripheral portions of the washers so that the peripheral portions of the washers will slide to the left relative to counterbore 34. This axial movement of the peripheral portions of the washers will cause the inner gripping corners 124, 136 and 150 of the washers to incise the surface of cable jacket 26 before the outer peripheries of the washers come into fixed engagement with counterbore 34.

As the bushings 82 and 90 are brought further together, the inner gripping corners 124, 136 and 150 of the respective conical washers 84, 86 and 88 will be further compressed radially inwardly to dig into the cable jacket 26 in the manner best shown in FIGURE 6, to provide a tight locking engagement with the cable jacket 26.

As the washers are thus distorted from their initial, unactuated positions of FIGURE 5 to their fully actuated positions of FIGURE 6, they will slide relative to each other until the outer edge surface 120 of washer 84 engages against the inwardly directed shoulder 140 of the flange 138 on washer 86, and the outer edge surface 132 of washer 86 engages against the inwardly directed shoulder 154 of the flange 152 on washer 88. Thus, in the fully actuated position shown in FIGURE 6, the shoulders 138 and 152 will couple the washers 84, 86 and 88 together for substantially uniform cable jacket penetration.

It will thus be seen that, regardless of external forces which may be applied on the cable, the gripping forces applied by the respective washers 84, 86 and 88 on the cable jacket 26 will be generally equally distributed, so that no single large distorting force is applied at any place along the cable. Similarly, relatively wide variations in temperature do not cause any particularly concentrated forces to be applied to the cable, and do not particularly alter the gripping engagement of the washers in the cable jacket 26.

During the actual penetration of the gripping corners 124, 136 and 150 into the cable jacket 26, the gripping corner 124 penetrates substantially radially inwardly into the cable jacket because of the combined inward sliding and anti-clockwise distortion of the washer 84 as viewed in FIGURES 5 and 6. The inward sliding and anti-clockwise distortion of the washers 86 and 88 is such that their gripping corners 136 and 150 are moved slightly to the left from their initial penetrating positions shown in FIGURE 5 to their final positions shown in FIGURE 6, whereby these gripping corners 136 and 150 will tend to draw the cable jacket 26 slightly tighter into the connector.

In the final gripping positions of the washers as shown in FIGURE 6, it will be noted that the inner edge surfaces 122, 134 and 148 of the respective washers 84, 86 and 88 will be substantially radially disposed, whereby these surfaces will provide a maximum locking engagement against the corresponding generally radial surfaces of the penetration grooves 172, 174 and 176, respectively, in the cable jacket 26.

In the presently preferred embodiment of our invention the angle of outside conical face 156 of bushing 90 relative to the axis of the connector will correspond to the final, distorted angles of the conical surfaces of the washers 84, 86 and 88. By thus defining the final angle of distortion of the washers against the outside conical face 156 of bushing 90, the amount of penetration of all of the washers is fixed, and the relative penetrations of the respective washers are likewise fixed.

In the final, flattened positions of the washers as shown in FIGURE 6, it will be noted that the outer peripheral corner 172 of washer 84, and the outer peripheral surfaces 168 and 170 of the flanges 138 and 152 on the respective washers 86 and 88, will tightly engage against the counterbore 34 of skirt 38. This operative engage-

ment, together with the gripping engagement of the sharp inner edges of the washers into the cable jacket 26, will provide an excellent seal between the tubular body of the connector and the cable jacket against the entrance of any low viscosity moisture.

It is to be noted that in the actuated or locking positions of the parts as shown in FIGURES 4 and 6, the bushing 90 is compressed sufficiently tightly against the take-up sleeve 102 by the distortion of the conical washers so that the take-up sleeve 102 is locked in place by a "lock-washer" action. Thus, the coupling will not accidentally become released due to vibrations, variations and temperature or the like.

By providing conical washers which are composed of a resilient material, such as beryllium copper, the washers will return substantially to their initial shapes as shown in FIGURES 2 and 5 when the coupling is released by unscrewing take-up sleeve 102 from skirt 38. Thus, the parts of the present coupling are not in any way damaged during operation, so that the various components are reusable.

It is to be noted that our present coupling may be operatively engaged to a cable and disengaged therefrom by merely utilizing conventional tools, such as conventional wrenches, and does not require the use of special tools.

Referring now to the electrical circuit between cables 12 and 14, the electrical conductor 16 of cable 12 is electrically operatively connected to the conductor 22 of cable 14 through the conductor collar 52 and through the conductor sleeves 54 and 56.

An excellent electrical connection is also provided between the metal cable jacket 20 of cable 12 and the metal cable jacket 26 of cable 14. This electrical connection is directly provided from cable jacket 20 through the conical washers 74, 76 and 78, thence through the skirt 36, tubular body 28 and skirt 38 to the right-hand conical washers 84, 86 and 88, and thence to the cable jacket 26. The penetration of the washers into the respective cable jackets, and the compression of the outer peripheries of the washers against the respective skirts 36 and 38 on the tubular body 28, provides an electrical connection between the cable jackets 20 and 26 which is positive.

It will also be apparent that the cable jackets 20 and 26 are in contact with the respective flanges 90 and 104 of the respective take-up sleeves 91 and 102, to provide an additional electrical connection between the cable jackets 20 and 26. Further, the cable jacket 20 will normally abut directly against the flange 40 on the tubular body 28 and the cable jacket 26 will normally abut against the annular ring 50.

It will be apparent that the present invention provides a means for positively engaging a cable in a connector, both mechanically and electrically, with a minimum amount of distortion of the cable jacket, and without requiring flaring or other similar forming of the cable jacket.

In FIGURES 8 and 9 of the drawings we have shown an alternative embodiment of our present invention employed in a retaining device 178 for gripping a metallic tubular conducting member 180 adapted for use in radio frequency transmission.

The retaining device 178 includes a body portion 182 having a tubular skirt 184 thereon. Tubular skirt 184 has an internal bore 186 which terminates at an annular, radially directed shoulder 188.

Annular bushing 190 is disposed within the inner or right-hand end of bore 186, the right-hand end of bushing 190 having a radially disposed annular face 192 which seats against the shoulder 188.

Bushing 190 is provided at its left-hand end with an inside conical face 194 within which nesting conical washers 196, 198 and 200 seat. The outermost washer

200 fits over the outside conical face 202 of the right-hand bushing 204.

The conical washers 196, 198 and 200, and the outermost bushing 204, are substantially the same in construction as the corresponding parts of the preferred embodiment shown in FIGURES 1 to 7 inclusive, except that the washers 196, 198 and 200 of the alternative embodiment of FIGURES 8 and 9 do not include flanges at their outer edges. Bushing 204 is, however, provided with flange 206 projecting from its conical surface 202.

The outer end 208 of bushing 204 is operatively engaged by a radially inwardly directed flange 210 at the end of a tubular nut 212 which is threadedly engaged over tubular skirt 184. Tightening of the tubular nut 212 will force the bushings 204 and 190 axially together against the washers 196, 198 and 200 to flare the washers into locking engagement with the cable jacket 184 and with the bore 192 of skirt 190.

The outer peripheral edge surfaces of the washers 196, 198 and 200 are preferably substantially at right angles to the conical surfaces of the washers, to provide outer gripping corners 214, 216 and 218 which are sufficiently sharp to incise the surface of bore 186 at the final actuated position shown in FIGURE 9. However, because of the axial force applied by the flange 206 on bushing 204 to the outer periphery of washer 200, and thus to the outer peripheries of the other washers, the inner gripping corners 220, 222 and 224 of the washers will incise the tubular member 180 during the early part of the compression of the washers between the bushing, before the outer gripping corners 214, 216 and 218 incise the wall of bore 186 at the final compressed positions of the washers.

It will be apparent that the alternative embodiment of our invention shown in FIGURES 8 and 9 not only tightly mechanically and electrically connects the cable to the connector, but also provides an efficient seal against the entry of low viscosity fluids into the electrical field of the connector, without requiring the use of any additional conventional sealing gaskets. The seal is provided by the conical washers 196, 198 and 200, the inner edges of which penetrate into the tubular member 180, and the peripheral edge portions of which penetrate into the surface of bore 186 of skirt 184.

It will be noted that in the embodiment of FIGURES 8 and 9 the opposed conical bushing surfaces 194 and 202 have substantially the same angle of incline relative to the axis, whereby these conical bushing surfaces 194 and 202 will engage flush against the adjacent conical washer surfaces when the washers are fully compressed between the bushings. This provides an excellent seal, and also determines the amount of penetration of the washers into the tubular member 180.

The alternative embodiment of FIGURES 8 and 9 thus produces maximum gripping action on the tubular member 180 with negligible distortion at the inner wall of tubular member 180. Also, the resultant grip produces excellent electrical characteristics without appreciably weakening the physical strength of tube 180.

The retaining device 178 of the alternative embodiment of FIGURES 8 and 9 is actually a type of electrical connector, and is included in that term as employed in the appended claims. Similarly all elongated members for conducting electricity will be referred to as "cables" in the appended claims, this term including but not being limited to both jacketed electrical conducting members, such as the cables 12 and 14 of FIGURE 1, and unjacketed conducting members such as the tubular radio frequency transmission members of FIGURES 8 and 9.

Although the present invention has been shown and particularly described in connection with metal jacketed cables and tubular conducting members, it is to be understood that the present invention is also applicable to cables and other elongated members having non-metallic

outer surface portions. In the case of non-metallic electrical cable jackets, we prefer to employ conical washers composed of a non-metallic, resilient material, such as a suitable plastic material, to minimize the possibility of injurious cutting into the cable jacket. However, metal conical washers of proper design may also be satisfactorily employed in connection with cables having non-metallic jackets.

While the instant invention has been shown and described herein, in what is conceived to be the most practical and preferred embodiment, it is recognized that departures may be made therefrom within the scope of the invention which is therefore not to be limited to the details disclosed herein, but is to be accorded the full scope of the claims.

Having thus described our invention, what we claim as new and desire to secure by Letters Patent is:

1. An apparatus for gripping an elongated member comprising: spaced first and second actuating members having opposed, annular, axially aligned faces, at least one of said members having an axial bore therethrough, said bore being adapted to receive an elongated member to be gripped, a resilient annular washer of frusto-conical shape disposed between and axially aligned with said faces and adapted to encircle said elongated member, said washer having outer and inner frusto-conical surfaces extending from an inner circumferential edge of the washer to an outer peripheral edge, the outer surface of said washer being disposed contiguous to the face of the first actuating member, said inner circumferential edge comprising a sharp annular gripping edge adapted to engage the elongated member and formed by a bevel contiguous with said inner circumferential edge of the

washer, the bevel extending at an obtuse angle from the outer frusto-conical surface of the washer radially inward to an acute angular intersection with the inner frusto-conical surface thereof and presenting an annular abutment disposed in a plane generally normal to the axis of the washer and confronting the face of the first actuating member, and means operatively engaging said actuating members to draw said actuating members axially together and compress the washer between the actuating members and thus constrict said inner circumferential gripping edge of the washer into penetrating engagement with said elongated member.

2. An apparatus as defined in claim 1 wherein a plurality of washers of the character defined are axially superimposed between the actuating members, and the respective actuating members bear against the adjacent surfaces of the washers adjacent thereto.

3. Apparatus as defined in claim 1 wherein said annular face of said first actuating member is in the form of a tapering countersink.

References Cited in the file of this patent

UNITED STATES PATENTS

2,445,580	Kasten	June 20, 1948
2,456,081	Penick	Dec. 14, 1948
2,456,203	Loepsinger	Dec. 14, 1948
2,474,880	Woodling	July 5, 1949
2,670,223	Ream	Feb. 23, 1954

FOREIGN PATENTS

641,793	France	Apr. 3, 1928
840,649	France	Jan. 23, 1939