

Sept. 20, 1960

W. L. G. HEÜSNER

2,953,343

TWO-PART MINE PROP

Filed Oct. 24, 1957

4 Sheets-Sheet 1

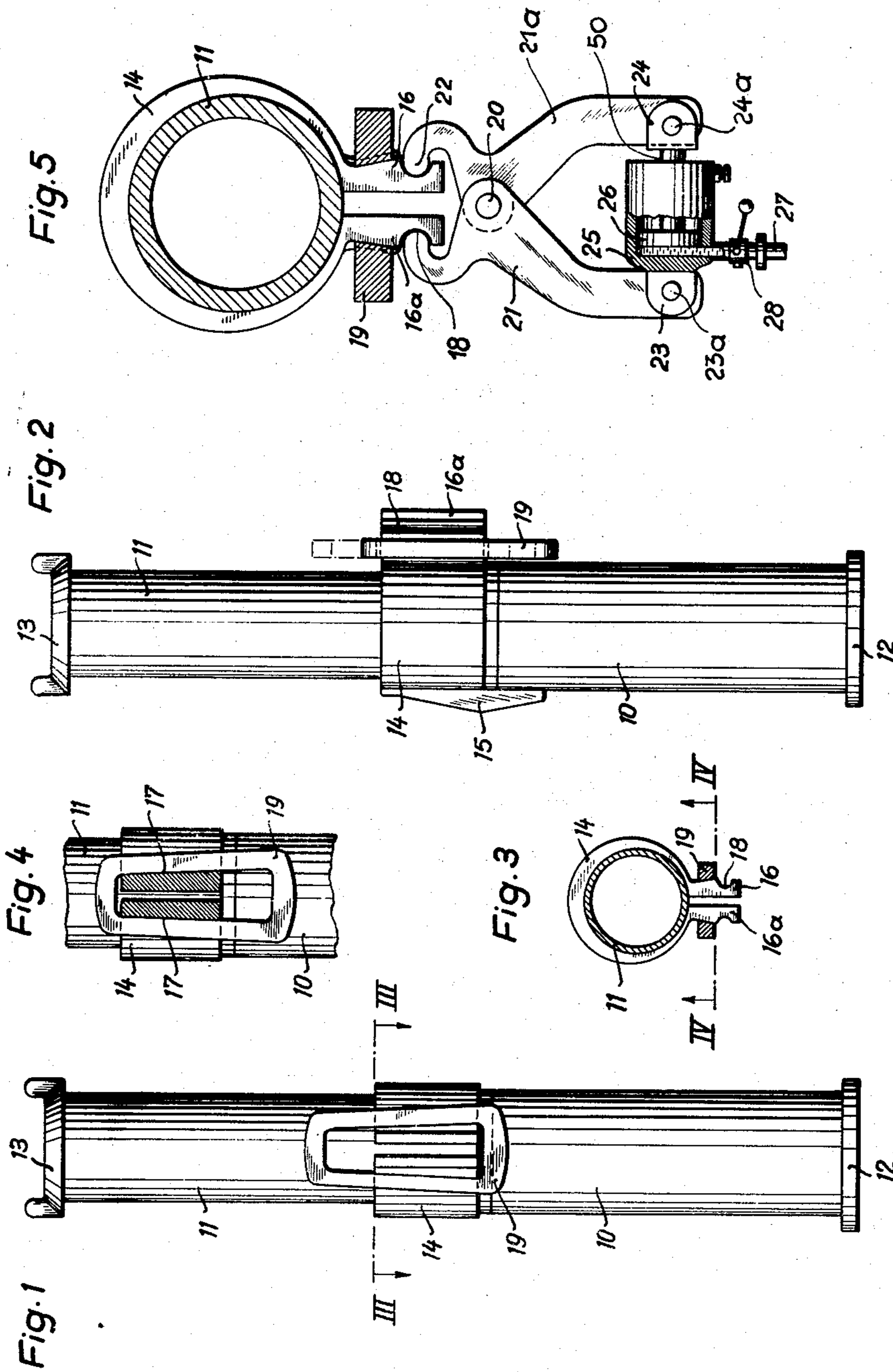

Sept. 20, 1960

W. L. G. HEÜSNER

2,953,343

TWO-PART MINE PROP

Filed Oct. 24, 1957

4 Sheets-Sheet 2

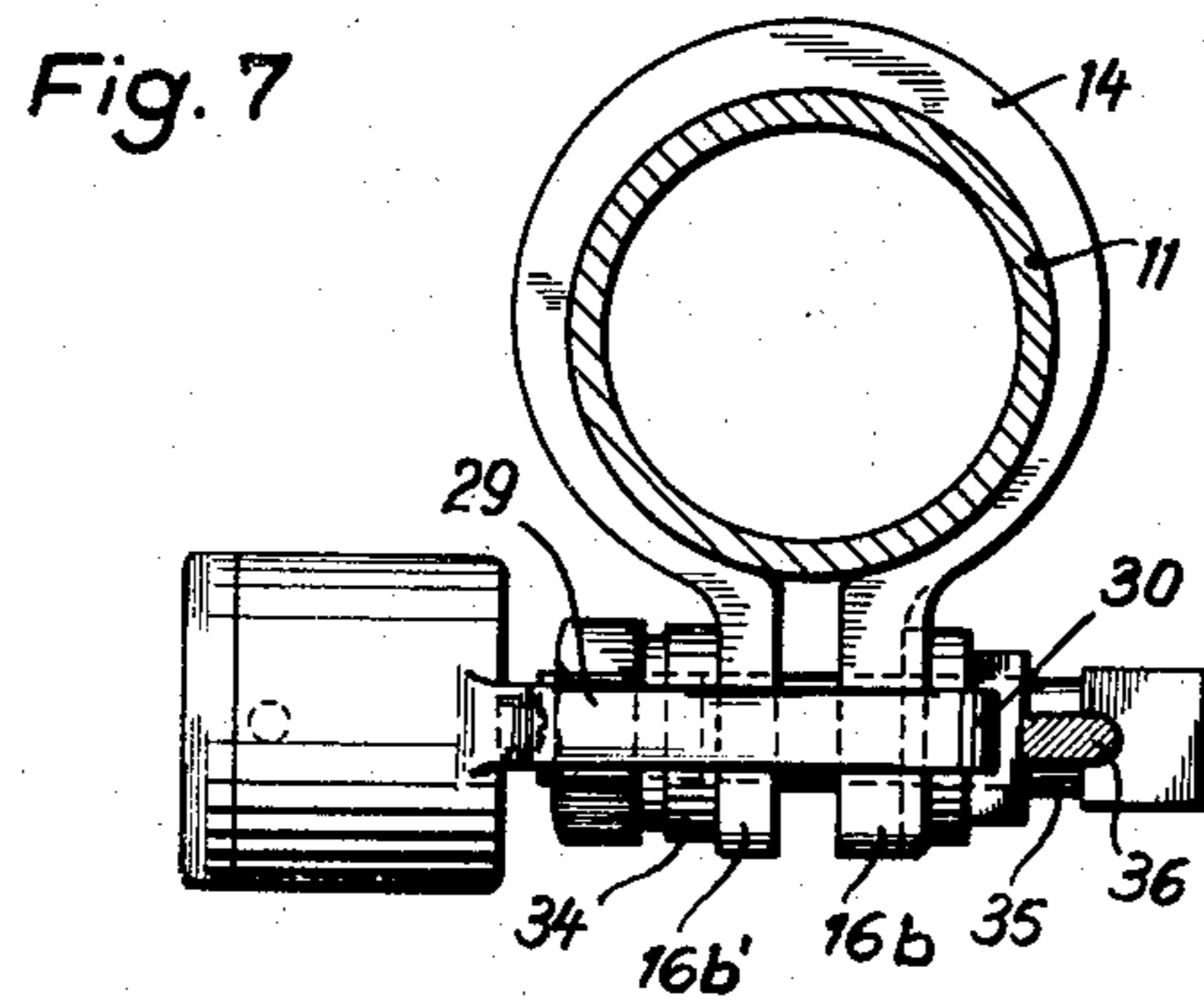
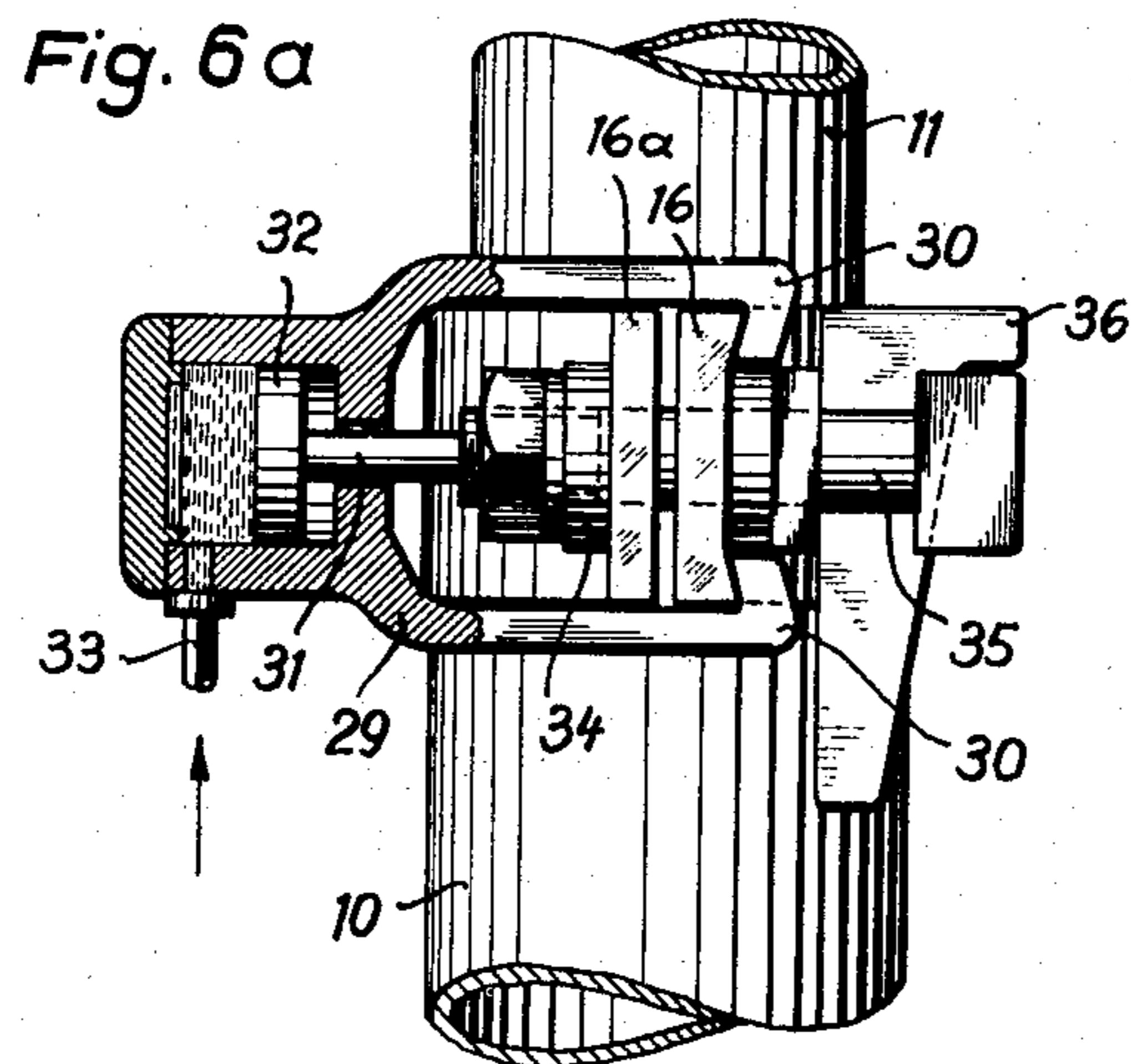
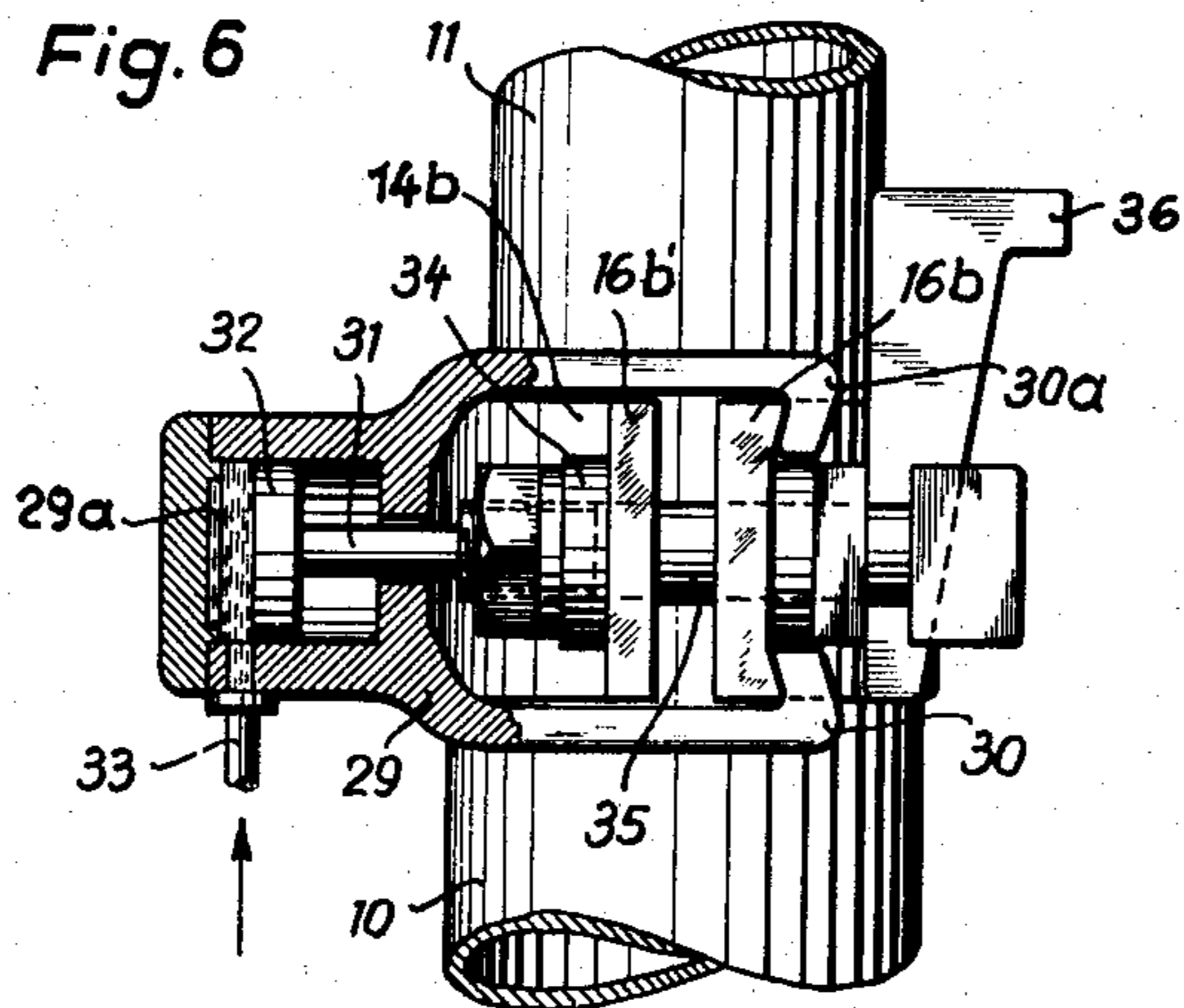

Sept. 20, 1960

W. L. G. HEUSNER
TWO-PART MINE PROP

2,953,343

Filed Oct. 24, 1957

4 Sheets-Sheet 3

Fig. 8

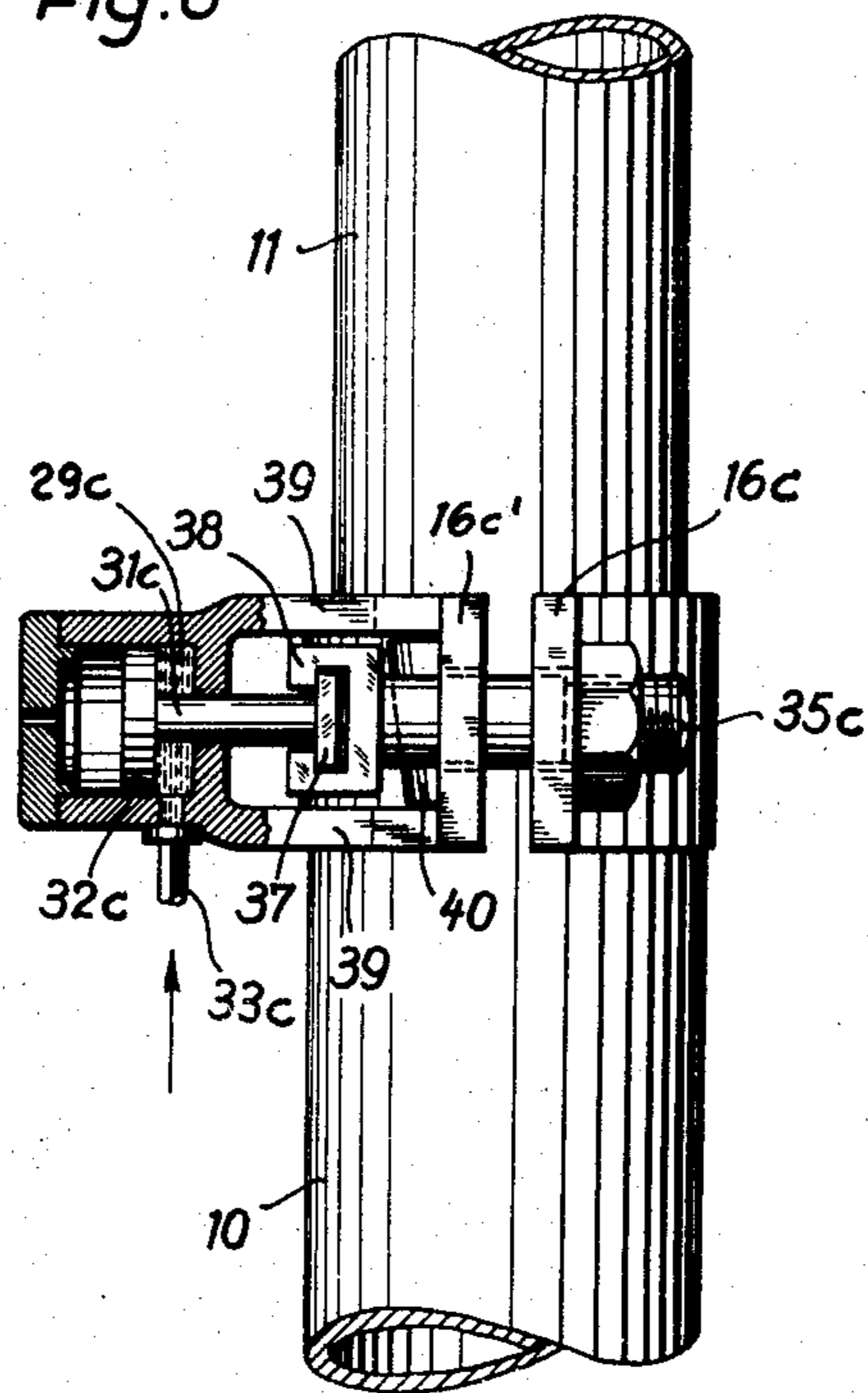
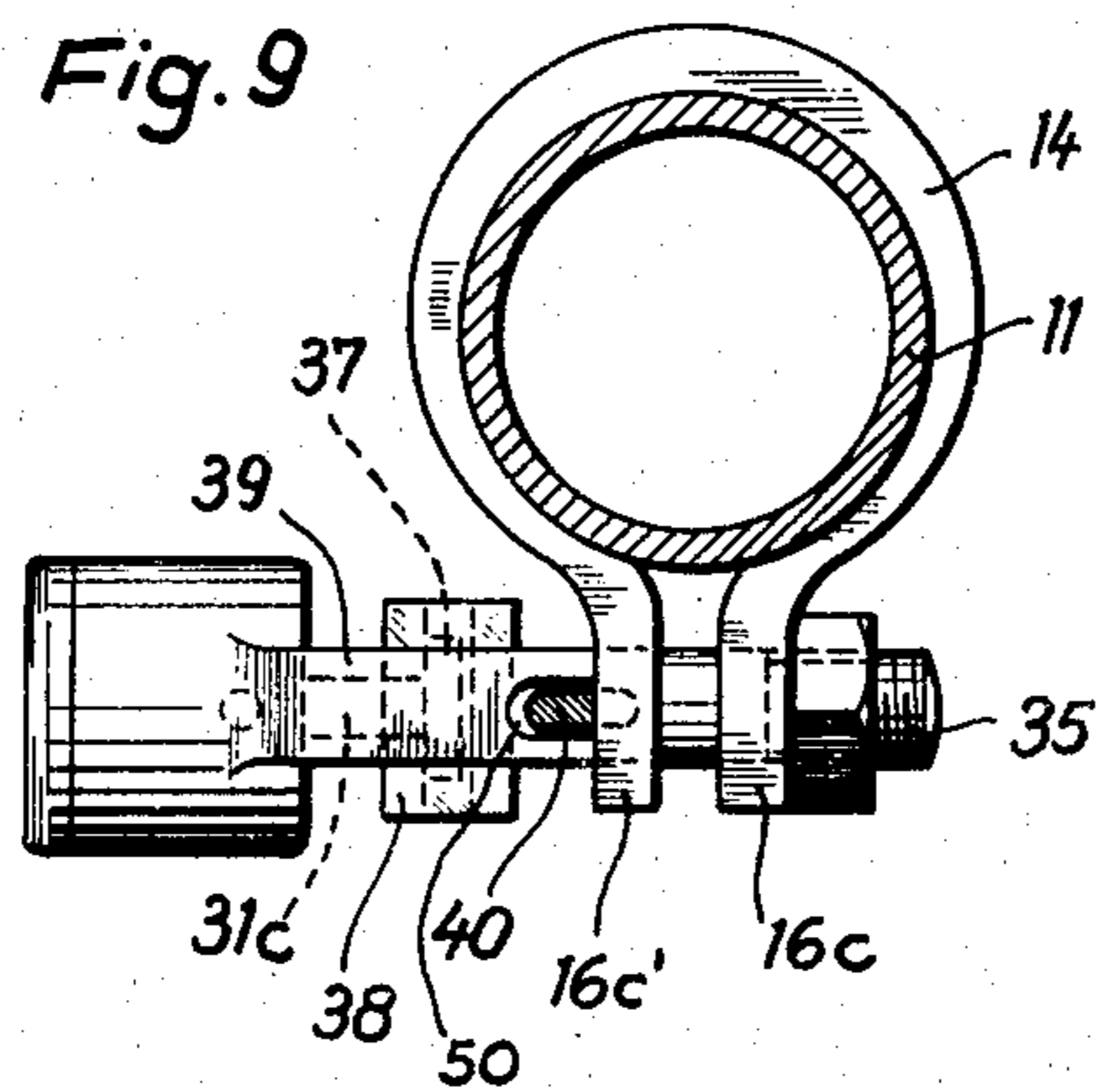

Fig. 9



Sept. 20, 1960

W. L. G. HEÜSNER

2,953,343

TWO-PART MINE PROP

Filed Oct. 24, 1957

4 Sheets-Sheet 4

Fig. 10

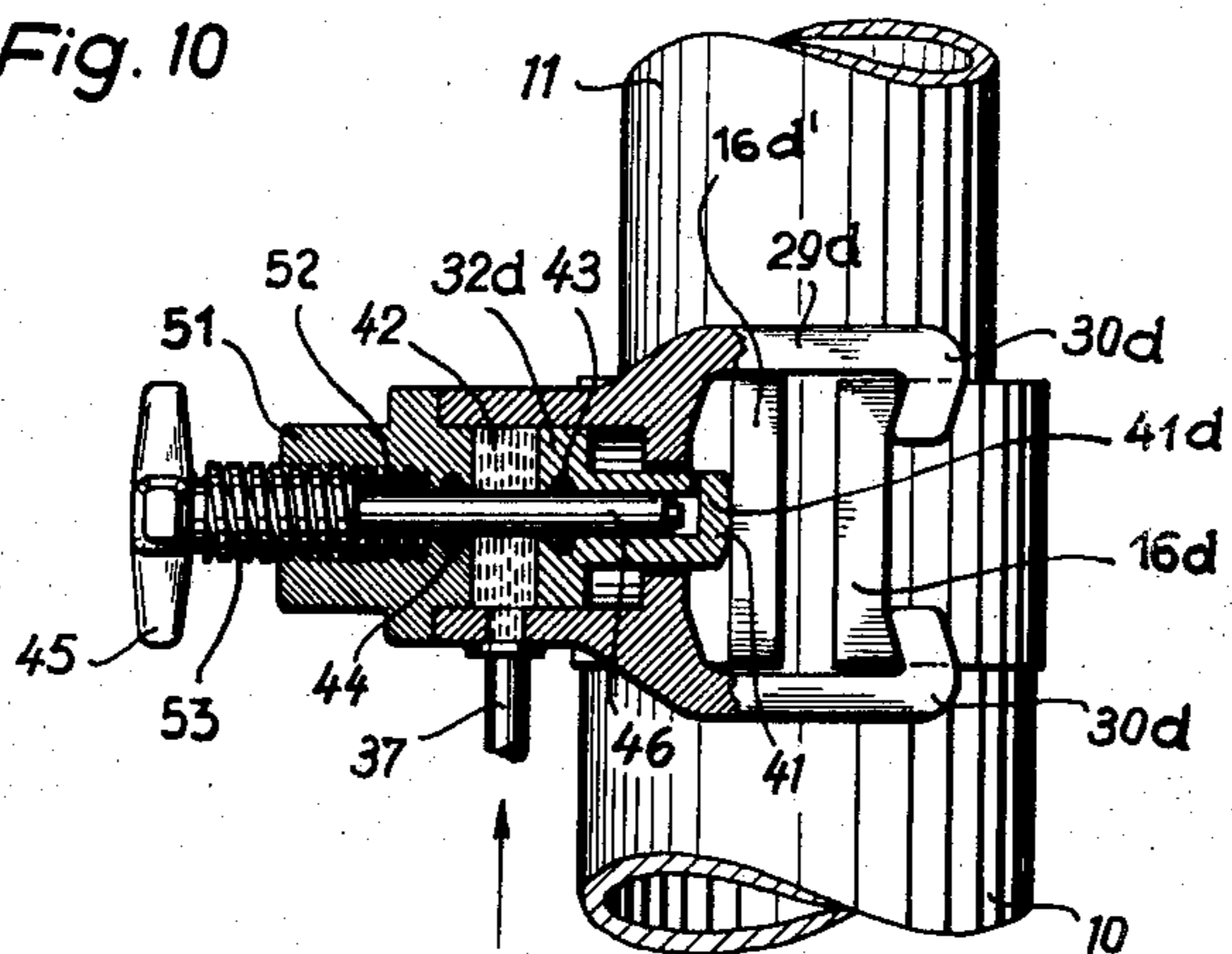

Fig. 10a

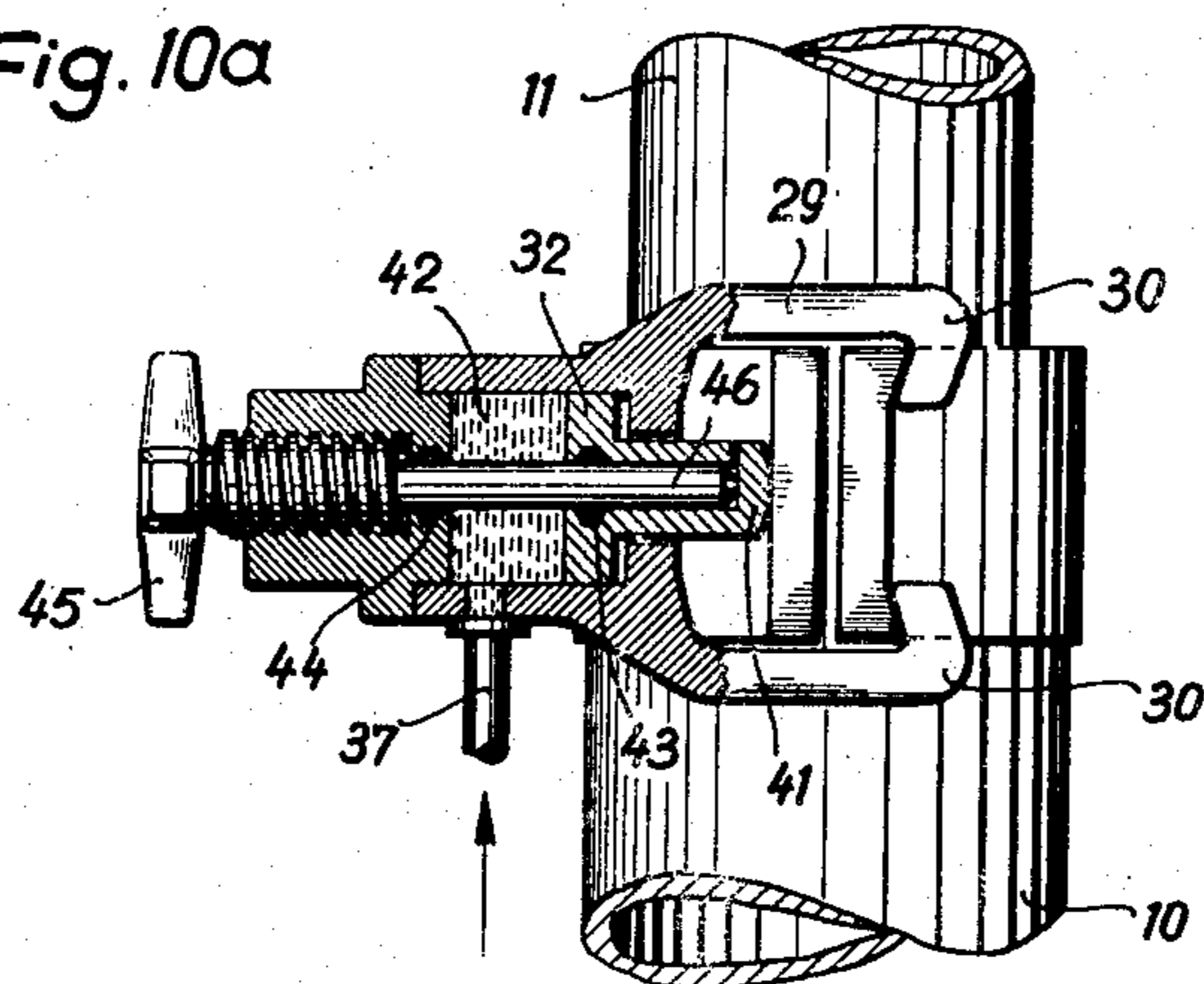
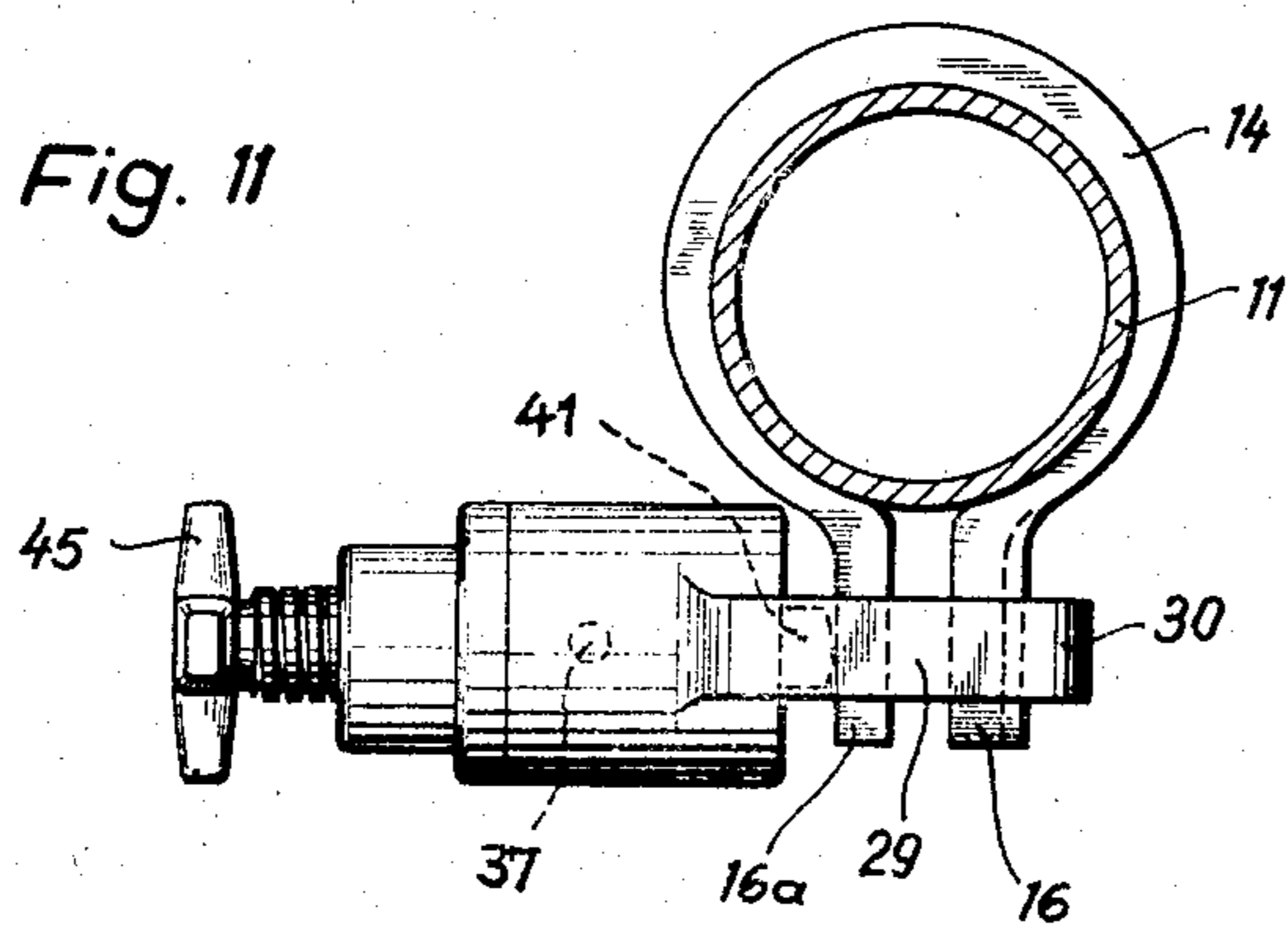

Fig. 11



1

2,953,343

TWO-PART MINE PROP

Wilhelm Ludwig Gustav Heisner, Bochum-Weitmar, Germany, assignor to Hermann Schwarz K.G., Watten-scheid, Germany

Filed Oct. 24, 1957, Ser. No. 692,152

10 Claims. (Cl. 248—354)

The present invention relates to a two-part metallic mine prop. With mine props of this type it is common knowledge to fix the two prop members, an upper prop member and a lower prop member, relative to each other in operating position by means of a prop lock, while for purposes of robbing or abstracting the prop, the two prop members are released so that they can telescope relative to each other.

With most two-part metallic mine props, the prop members are held relative to each other in their supporting position by a frictional force preventing the sinking of the upper prop member. This frictional force depends on the frictional surfaces of said two prop members, which are in frictional engagement with each other and also on the pressure at which said frictional surfaces are pressed against each other, said pressure generally being produced by the elastic deformation of one or a plurality of locking elements. Thus, the magnitude of the frictional force is among others dependent on the obtainment of a certain degree of deformation of the locking elements during the tightening of the lock.

In order that the supporting ability will be at least approximately uniform for all mine props installed at the same working station, it is necessary to apply uniform force to each mine prop in order to obtain uniform elastic deformation of the lock element. If the elastic deformation of the locking elements is obtained by wedge means, it is necessary to drive the locking wedges at such a force that the same end condition will be obtained with each mine prop at the same working station. It is obvious that such a condition cannot be realized in view of the fact that it is impossible for human beings to develop such fine discriminative feel, particularly since also differences in the material of the respective locking elements are unavoidable.

It is, therefore, an object of the present invention to provide a two-part mine prop, in which the elastic deformation of the locking elements will be approximately the same with all mine props installed at the same working station.

It is another object of this invention to provide a mine prop of the type set forth in the preceding paragraph, in which the prop members of each mine prop will be held in their finally set position by a mechanical latching mechanism.

It is another object of this invention to provide a two-part mine prop, in which the prop members can be clamped against each other at a certain precisely defined predetermined pressure by means of a clamping ring connecting the upper prop member with the lower prop member for bringing about frictional engagement between the upper and lower prop members.

It is still another object of this invention so to design a clamping ring for clamping the upper and lower prop members of a mine prop together that the frictional pressure at which the inner surface of the clamping ring acts upon the upper prop member will have at least

2

nearly uniform pressure along the entire circumference of said clamping ring.

It is a further object of this invention so to design the frictional pressure producing means for a two-part mine prop that said frictional producing means may selectively be detached from the mine prop to reduce the weight of the mine prop.

These and other objects and advantages of the invention will appear more clearly from the following specification in connection with the accompanying drawings, in which:

Fig. 1 diagrammatically illustrates the front view of a mine prop with a clamping ring according to the invention.

Fig. 2 is a side view of the mine prop shown in Fig. 1. Fig. 3 is a section taken along the line III—III of Fig. 1.

Fig. 4 is a vertical section taken along the line IV—IV of Fig. 3.

Fig. 5 is a horizontal section through a mine prop similar to that of Fig. 3 but on a larger scale than the latter and equipped with a clamping pressure producing device.

Fig. 6 is a side view of a modified clamping lock, showing the locking mechanism in open position.

Fig. 6a is a view similar to that of Fig. 6 but with the locking mechanism in locked or latched condition.

Fig. 7 is a top view of Fig. 6.

Fig. 8 represents the side view of a further modification of a mine prop locking arrangement according to the invention.

Fig. 9 is a top view of the lock shown in Fig. 8.

Fig. 10 represents a side view of a further modified mine lock in opened condition.

Fig. 10a shows the mine lock of Fig. 10 in closed position.

Fig. 11 is a top view of the arrangement shown in Fig. 10.

General arrangement

The mine prop according to the invention is characterized primarily in that the parts of the mine prop in working condition of the latter are while elastically deforming the same tightened relative to each other and are mechanically latched, while the tightening of the lock is effected by a fluid pressure operable device. The actuating fluid may be in gaseous or liquid condition. As actuating fluid or pressure medium among others compressed air may be used which is amply available in mining installations. If desired, however, the pressure fluid means may be compressed by means of a corresponding pump. Also water or oil may be employed as pressure fluid. In some instances the pressure in the strut water line will suffice in order to produce the power in the fluid pressure operable device for producing the tightening action.

When the fluid pressure operable tightening device has brought about the desired elastic deformation and thereby the required tightening of the lock, the latching of the lock is effected mechanically. Locking means to this end may comprise a wedge, a clamping screw, or other adjustable locking means. After such locking means have become effective, the pressure fluid in the fluid pressure operable device may be released therefrom.

In order to be able at high precision to maintain the locking tension produced by the fluid pressure operable device and to do so by a mechanical latching mechanism, the arrangement is in conformity with a further development of the invention so selected that with a two-part mine prop according to the invention, the fluid pressure operable clamping device will attack at the lock in the same plane as the device employed for latching the lock

under tension. In this way it will be possible precisely to maintain the clamping effect in the lock obtained by the hydraulic clamping device, at precisely the adjusted value without running the risk that when lowering the hydraulic pressure or when removing the clamping device, a change in the clamping condition will occur.

A very important field of employment of the present invention is the employment of such two-part mine props in which the upper prop member and also the lower prop member are in frictional engagement with each other through the intervention of a clamping ring connected to the lower prop member. Preferably, the upper prop member as well as the lower prop member are designed as hollow cylinders or hollow cylindrical tubes. The tightening of the clamping ring is with a mine prop of the above mentioned type effected by pulling toward each other the two ears connected to or forming a part of the free ends of the clamping ring. The forces exerted upon the ears when tightening the clamping ring first act in circumferential direction. By means of the ring, the said forces are split up in radially directed force components which produce the important frictional pressure for tightening the mine prop members relative to each other. This frictional pressure should be substantially uniform along the circumference of the clamping ring. In order to obtain this goal, in conformity with the present invention, the clamping ring is so designed that its cross section beginning from the ends increases gradually toward the center in the manner of a girder of uniform resistance. In this way, the forces acting upon the ends of the clamping ring are sub-divided and distributed over the entire prop circumference to produce a uniform frictional pressure. While the fluid pressure operable clamping device contracts the clamping ring at the ends thereof to an ever increasing extent, the deforming forces exerted in this way upon the clamping ring are distributed in such a way that at the end condition of the tightening operation, a uniform frictional pressure is exerted upon the upper mine prop member. This tensioning condition is then maintained by making the mechanical latching means effective for the entire period in which the mine prop occupies its working position.

Structural arrangement

Referring now to the drawings in detail and Figs. 1 to 5 thereof in particular, the mine prop shown therein comprises a tubular lower prop member 10 telescopically engaged by an upper tubular prop member 11. The prop member 10 is provided with a foot 12 while the upper prop member 11 is provided with a head 13. The device furthermore comprises a clamping ring 14 the free ends of which have connected thereto ears 16 and 16a. The lower prop member 10 and the clamping ring 14 are connected to each other by a band 15 connected to said clamping ring and said lower prop member 10 in any convenient manner for instance by welding.

As will be evident from Figs. 3 and 5, the thickness of the clamping ring increases in a continuous manner from the ears 16 and 16a toward that portion which is diametrically opposite the gap between said ears. The height of the clamping ring is the same along the entire circumference thereof as is particularly clearly shown in Figs. 1 and 2. The increase in the cross section from the ears 16, 16a toward that portion of the clamping ring which is diametrically opposite the gap between the ears 16, 16a is such that the strength of the clamping ring is substantially uniform throughout the same in the manner of a girder of even strength. Such an arrangement brings about the advantage that the force exerted upon the ends of the clamping ring is split up into such radial force components that the frictional pressure exerted by the clamping ring 14 upon the tubular upper prop member 11 will have approximately the same value through-

out the circumference of the clamping ring when the latter is in clamped condition.

With the arrangement according to Figs. 1 to 5, the ears 16 and 16a increase in thickness from their connecting point with the clamping ring 14 towards the outside, their lateral surfaces 17 being inclined as shown in Fig. 4. The said ears are provided with grooves 18 adapted to be engaged by the jaws 22 of the plier-like arranged arms 21 and 21a which are pivotally connected to each other by a pivot 20. The outer ends of the arms 21 and 21a are pivotally connected by pivots 23a and 24a to ears 23 and 24 respectively. The ear 23 is connected to a pressure cylinder 25, whereas the ear 24 is connected to a piston rod 50 which in its turn is connected to the piston 26 reciprocally mounted in the pressure cylinder 25. The cylinder 25 communicates with a pipe 27. A relief valve 28 is interposed between the pipe 27 and the cylinder 25.

When the mine prop has been adjusted as to height and when the clamping ring is to be tightened, the jaws 22 of the arms 21, 21a are caused to engage the recesses 18, and pressure fluid is conveyed to the cylinder 25 through pipe 27 and valve 28. As a result thereof, the clamping ring is contracted. The piston 26 moves relative to the cylinder 25 until a certain maximum pressure has been established within the cylinder piston system 25, 26 which maximum pressure is determined by the setting of the relief valve 28. The trapezoidal wedge-shaped body 19 drops during the tightening operation effected by the clamping ring from the position shown in Fig. 1, which position corresponds to the open position of the clamping ring, into the position shown in Fig. 4 along the inclined surfaces 17 of the clamping ring. Thus, the lock when in tightened condition is latched by the member 19. When relieving the fluid from the cylinder piston system 25, 26, the plier-like device 21, 21a can be opened and can be withdrawn from the ears 16, 16a of the clamping ring, while the mine prop remains in operative position in view of the locking by the member 19.

When robbing or abstracting the mine prop, it is merely necessary to knock the wedge body 19 upwardly whereby the clamping ring 14 will be released and the upper prop member 11 will due to its own weight sink downwardly.

According to the embodiment shown in Figs. 6, 6a and 7, the tightening device is provided with a fork-shaped portion 29 the ends of which are provided with jaws 30, 30a respectively. These jaws catch from above and below behind the ears 16b of the clamping ring 14b, whereas the piston rod 31 connected to the piston 32 due to fluid pressure admitted through pipe 33 acts through a collar 34 connected to piston rod 31 upon the ear 16b'. In this way, the ears 16b and 16b' are moved toward each other thereby bringing about a tightening of the clamping ring 14b. The wedge 36 will then move downwardly in a slot provided in bolt 35 which is connected to the ear 16b'. In this way the lock is latched or locked in its respective tightened position. After the wedge 36 has latched the lock, the pressure fluid may be relieved from the cylinder 29a so that the piston rod 31 may be pushed back and the entire tightening device including the cylinder 29a with fork 29 and jaws 30, 30a may be removed from the mine prop while the latter remains in its operative position due to the wedge 36. The tightening device may then be used for tightening the lock of another mine prop.

As has been particularly clearly shown in Fig. 7, those points where the jaws of the tightening element or the latching bolts are effective upon the ears 16b and 16b' are located in the same plane.

According to the arrangement shown in Figs. 8 and 9, the piston rod 31c of the piston 32c is provided with a head 37 which is located within the jaw 38 which latter

is connected to one end of the bolt 35c. If pressure fluid is conveyed into the cylinder 29c through the conduit 33c, the piston rod 31c will pull the bolt 35c toward the left with regard to Fig. 8 thereby also moving the ear 16c which is connected to bolt 35c toward the left. Similarly the pressure acting in the cylinder 29c moves the fork-shaped portion 39 toward the right thereby causing the ear 16c' engaged by the fork-shaped portion 39 to move toward the right so that the ears 16c and 16c' are moved toward each other thereby tightening the clamping ring. This arrangement is furthermore provided with a wedge 40 which in its effect corresponds to the wedge 36 of Fig. 6a and extends through a corresponding slot 50. This wedge 40 brings about the locking or latching of the clamping device.

The tightening device according to Figs. 10, 10a and 11 is likewise so designed that one of the two ears namely the ear 16d is grasped by the jaws 30d of the fork-shaped portion 29d, whereas the piston 32d has connected thereto a hollow piston rod 41 which is adapted to engage the ear 16d'. Extending into the hollow piston 41 is a bolt 46 which extends into the cylinder head 51 which latter is provided with a threaded bore 52. The threaded bore 52 is engaged by a correspondingly threaded bolt 53 provided with a handle 45.

If pressure fluid is admitted through conduit 37 into the cylinder 42, the ears 16d and 16d' are moved toward each other. When the lock is properly tightened, the threaded bolt 53 by means of the handle 45 is rotated so as to cause the bolt 46 to engage the end wall 41d of the hollow piston rod 41. In this way, the tightening device is mechanically locked so that the pressure fluid may be released from the cylinder 42.

The arrangement according to Figs. 10, 10a and 11 is furthermore provided with sealing means 43 and 44 to prevent pressure fluid from entering the interior of the tightening elements, especially the thread 52 in the cylinder head 51.

It is, of course, to be understood that the present invention is, by no means, limited to the particular constructions shown in the drawings but also comprises any modifications within the scope of the appended claims.

What I claim is:

1. A two-part mine prop comprising inner and outer telescoping members, a clamping element carried by the telescoping end of the outer member operable to clamp the inner member to secure said members against telescoping movement, a force applying device adjustable to exert a desired force engageable with said clamping element to actuate said element to clamp said inner member, and a locking member movable to engage said clamping element to lock said clamping element upon actuation to clamp said inner member.

2. In combination in a lock arrangement for a mine prop having a first prop member and a second prop member telescopically movable in said first prop member: clamping ring means carried by said first prop member and adapted to be tightened to thereby clamp said prop members together in their respective relative position, pressure fluid operable means detachably supported by one of said prop members and detachably engaging said clamping ring means, said pressure fluid operable means being operable to tighten said clamping ring means, and mechanical locking means engaging said clamping ring means and operable mechanically to lock said clamping ring means in the tightened position into which it was moved by said pressure fluid operable means and to hold said clamping ring means in said tightened position regardless of the status of operation of said pressure fluid operable means.

3. An arrangement according to claim 1, in which said pressure fluid operable means and said mechanical locking means are arranged to act upon said clamping ring means in substantially one and the same plane.

4. In combination in a lock arrangement for a mine

prop having a first prop member and a second prop member telescopically movable in said first prop member: clamping ring means carried by said first prop member and adapted to be tightened to thereby clamp said prop members together in their respective relative position, pressure fluid operable means supported by one of said prop members and operable to engage said clamping ring means for tightening the same, pressure relief valve means associated with said pressure fluid operable means for limiting the tightening force exerted by said pressure fluid operable means upon said clamping ring means to a predetermined value, and mechanical locking means for engaging said clamping ring means and for mechanically locking said clamping ring means in tightened position of the latter.

5. In combination in a lock arrangement for a mine prop having a lower prop member and an upper prop member telescopically movable in said lower prop member: an open clamping ring member having its free ends provided with ears spaced from each other and being connected to said lower prop member, the cross section of said clamping ring member increasing from said ears toward a line substantially opposite the gap between said ears, a fluid pressure cylinder piston assembly supported by said lower prop member and operable to engage said ears and to move the same toward each other to thereby tighten said clamping ring member and effecting frictional connection between said prop members, and mechanical locking means biased to engage said clamping ring member and mechanically to lock the same in its respective tightened position.

6. In combination in a lock arrangement for a mine prop having a first prop member and a second prop member telescopically movable in said first prop member: an open clamping ring having its free ends provided with ears extending outwardly, said clamping ring being carried by said first prop member and being adapted to be tightened to thereby clamp said prop members together and to hold the same in frictional engagement with each other, pressure fluid operable means supported by one of said prop members, power conveying means operatively connected to said pressure fluid operable means and arranged to convey clamping pressure from said pressure fluid operable means to said clamping ring through said ears, and a frame-like locking member having a trapezoidal cutout with the inclined sides thereof arranged for engagement with said ears and movable relative to said ears to hold said ring in its respective tightened position.

7. In combination in a lock arrangement for a mine prop having a lower prop member and an upper prop member telescopically movable in said lower prop member: an open clamping ring member having its free ends provided with a first ear and a second ear spaced from each other, said clamping ring member being connected to said lower prop member, a cylinder carried by said lower prop member and adapted to receive pressure fluid, a piston reciprocally mounted in said cylinder, a piston rod connected to said piston, a bolt extending through and in sliding engagement with said ears, said bolt being operatively connected to said piston and having a slot therethrough, the outer end of said bolt being provided with abutment means for engagement with said second ear, said cylinder having arms for engagement with said first ear, and a wedge-shaped locking member extending through said slot.

8. In combination in a lock arrangement for a mine prop having a lower prop member and an upper prop member telescopically movable in said lower prop member: an open clamping ring member having its free ends provided with a first ear and a second ear spaced from each other, said clamping ring member being connected to said lower prop member, a cylinder carried by said lower prop member and adapted to receive pressure fluid, a piston reciprocally mounted in said cylinder, a piston rod connected to said piston and to said first ear of said

clamping ring member, said cylinder being provided with arms for engagement with said second ear, a bolt slidably extending through said second ear and connected to said first ear, said bolt being provided with a slot between the outer end of said bolt and said second ear, and a wedge member having a tapered side and extending through said slot.

9. In combination in a lock arrangement for a mine prop having a first prop member and a second prop member telescopically movable in said first prop member: an open clamping ring member carried by said first prop member and adapted to be tightened to thereby clamp said prop members together in their respective relative position, said clamping ring member having its open ends provided with outwardly extending ears, a cylinder adapted to receive pressure fluid, a piston reciprocally mounted in said cylinder, a piston rod connected to said piston, and a pair of arms pivotally interconnected in a plier-like manner and having one end thereof pivotally connected to said cylinder and said piston rod respectively and having the other ends respectively in engagement with said ears for moving said ears toward each other in response to pressure fluid entering said cylinder and effecting relative movement between said cylinder

and said piston to thereby move said ears toward each other and tighten said clamping ring member.

10. A two-part mine prop comprising inner and outer telescoping members, a clamping ring carried by the telescoping end of the outer section and contractible to engage and clamp the inner section, a locking member movable to engage and lock said clamping ring in any contracted position, said locking member being biased toward locking position, and a clamping device adjustable to exert a desired force engageable with said clamping ring to contract said clamping ring into clamping engagement with said inner member so that said locking member will move into locking engagement to maintain said clamping ring in clamping engagement with said inner member.

References Cited in the file of this patent

UNITED STATES PATENTS

2,433,413 Williams ----- Dec. 12, 1950

FOREIGN PATENTS

921,563 Germany ----- Dec. 20, 1954

927,146 Germany ----- May 2, 1955

1,027,658 France ----- May 13, 1953

UNITED STATES PATENT OFFICE
CERTIFICATION OF CORRECTION

Patent No. 2,953,343

September 20, 1960

Wilhelm Ludwig Gustav Heusner

It is hereby certified that error appears in the above numbered patent requiring correction and that the said Letters Patent should read as corrected below.

In the grant, line 1, and in the heading to the printed specification, line 3, name of inventor, "Wilhelm Ludwig Gustav Heusner", each occurrence, read -- Wilhelm Ludwig Gustav Heusner --; in the drawings, Sheets 1 to 4, in the headings thereof, name of inventor, for "W. L. G. Heusner", each occurrence, read -- W. L. G. Heusner --.

Signed and sealed this 25th day of April 1961.

(SEAL)

Attest:

ERNEST W. SWIDER
Attesting Officer

DAVID L. LADD
Commissioner of Patents