

Sept. 2, 1958

T. E. SUESS

2,850,325

NOZZLE AND CONTROL ASSEMBLY FOR THE INTRODUCTION OF
FLUID MATERIAL INTO A HEATED CHAMBER

Original Filed Jan. 16, 1951

3 Sheets-Sheet 1

FIG. 1.

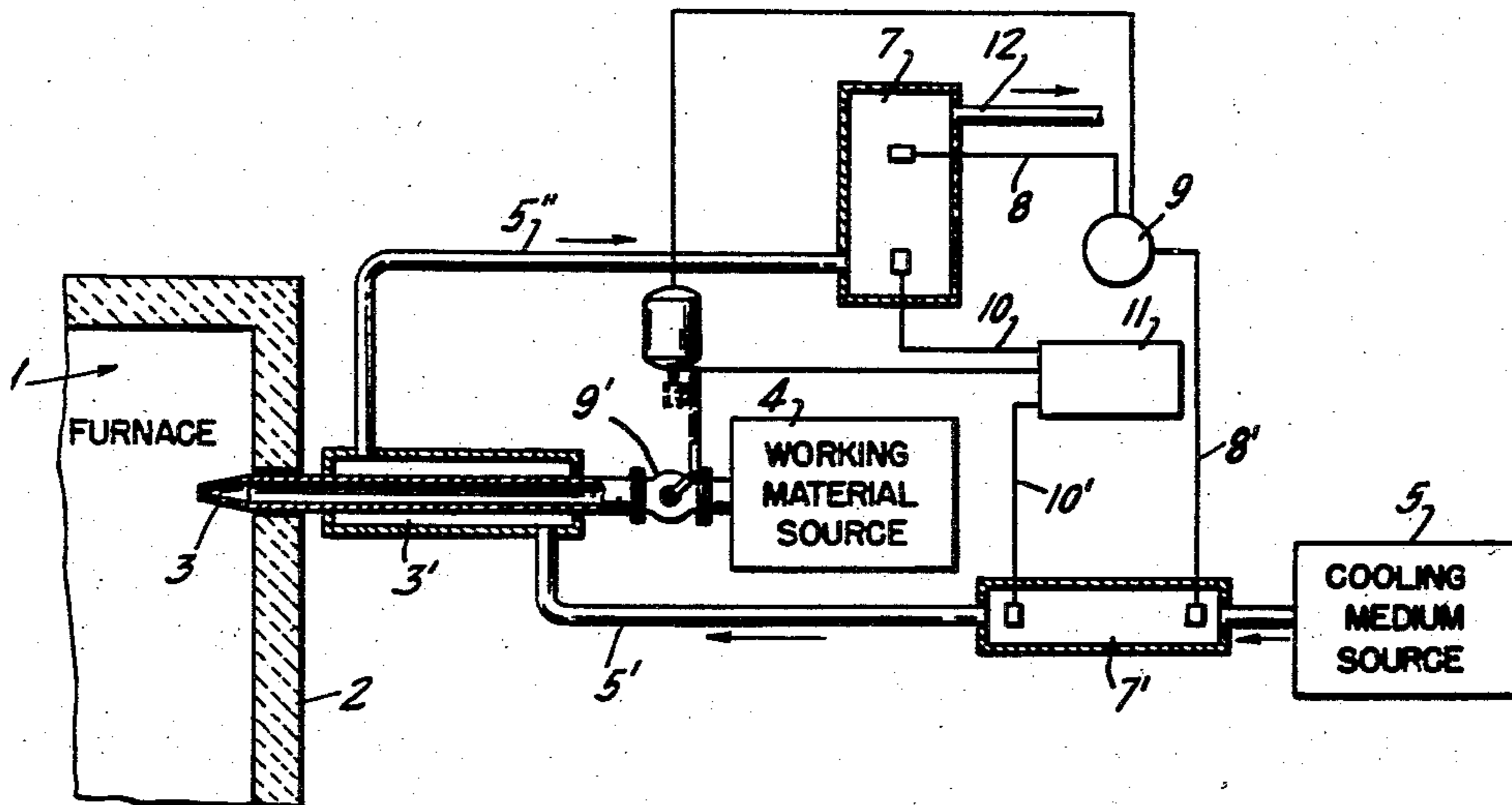
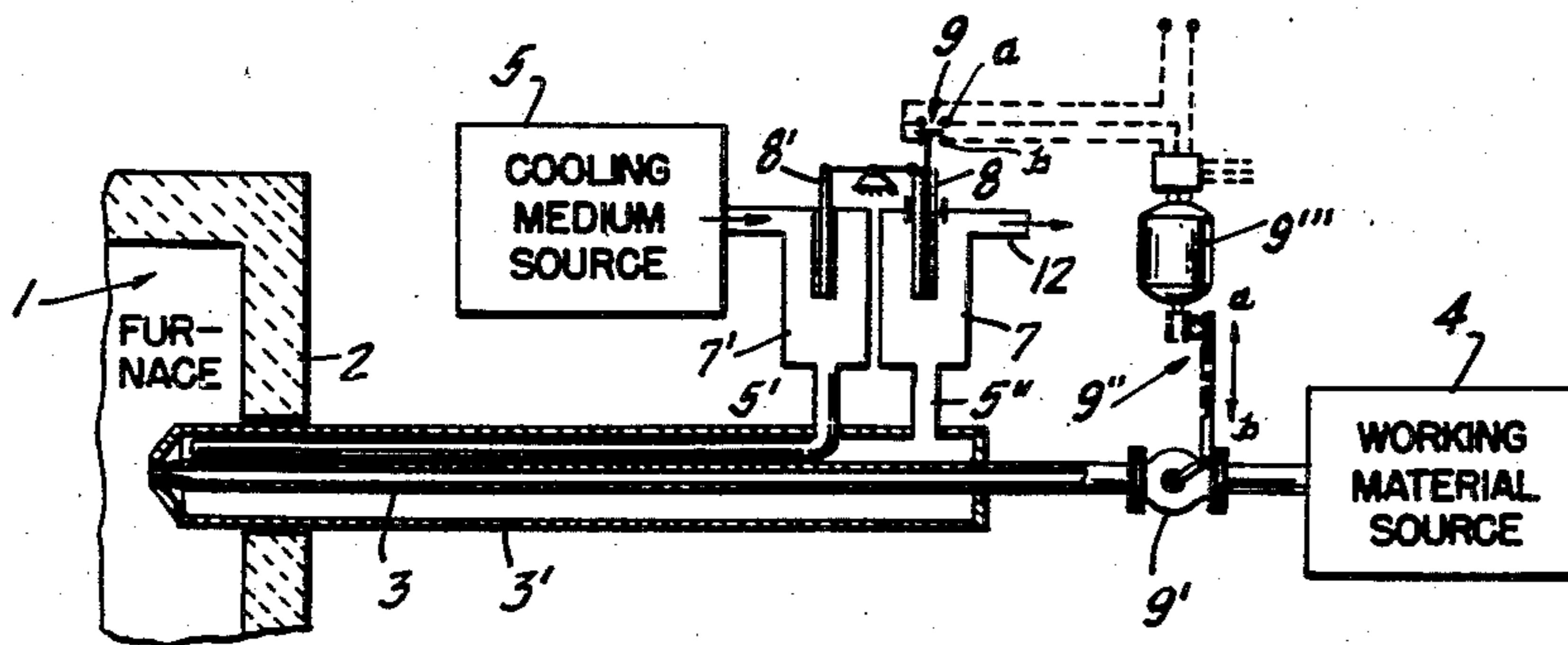

FIG. 2.



INVENTOR.
THEODOR EDUARD SUESS

BY

Prumbaugh, Free, Graves & Donohue

his ATTORNEYS

Sept. 2, 1958

T. E. SUESS

2,850,325

NOZZLE AND CONTROL ASSEMBLY FOR THE INTRODUCTION OF
FLUID MATERIAL INTO A HEATED CHAMBER

Original Filed Jan. 16, 1951

3 Sheets-Sheet 2

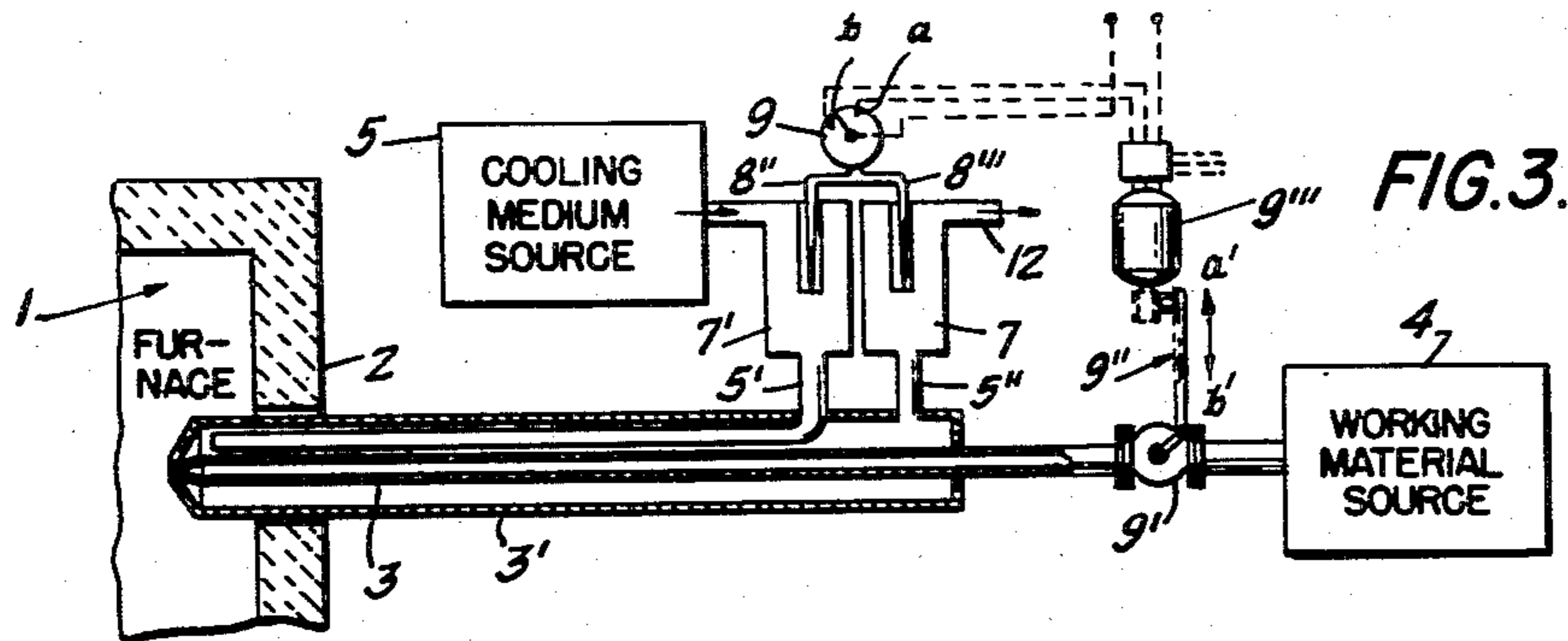

FIG. 3.

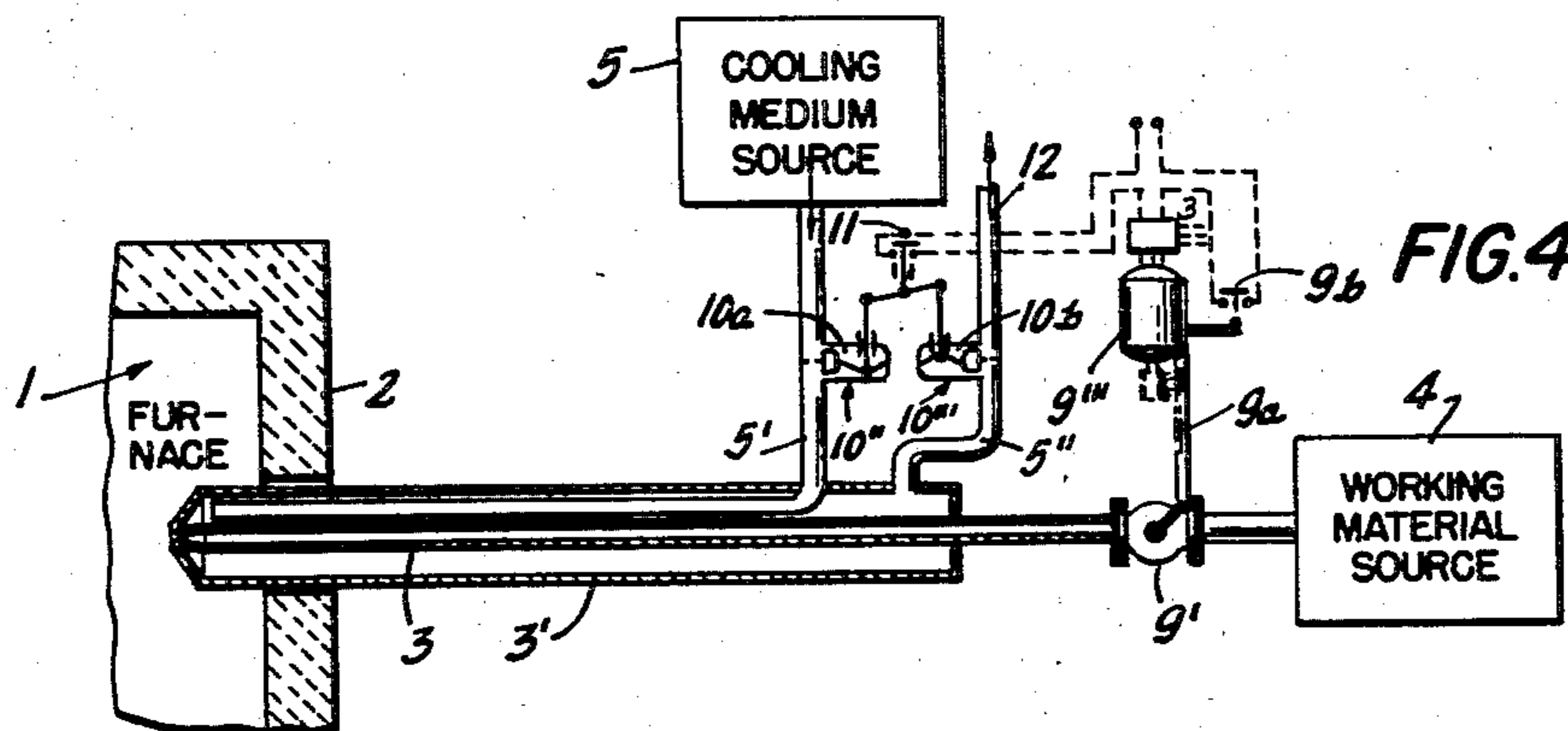

FIG. 4.

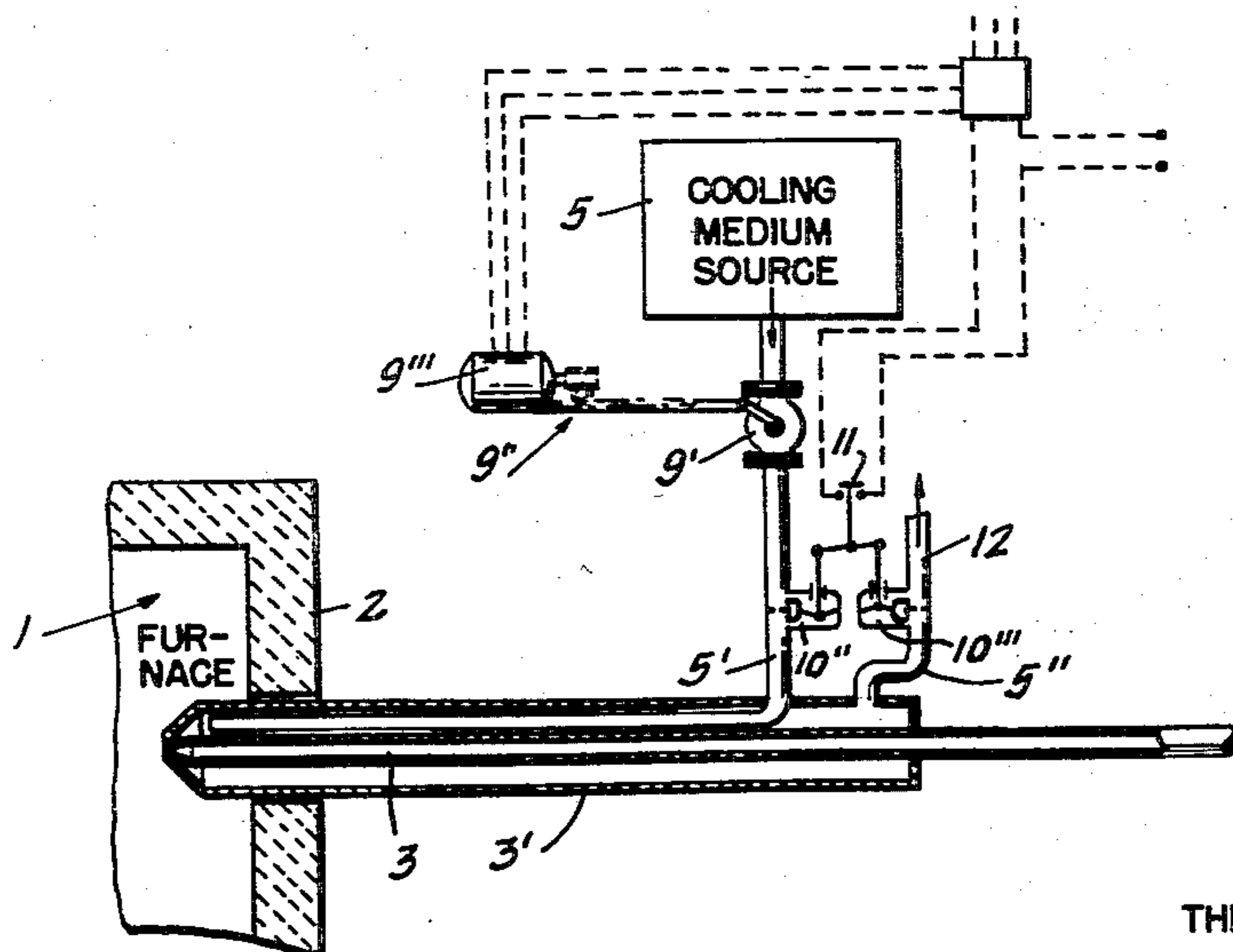

FIG. 5

INVENTOR.
THEODOR EDUARD SUESS

BY

Brumby, Free, Jones & Donohue

his ATTORNEYS

Sept. 2, 1958

T. E. SUESS

2,850,325

NOZZLE AND CONTROL ASSEMBLY FOR THE INTRODUCTION OF
FLUID MATERIAL INTO A HEATED CHAMBER

Original Filed Jan. 16, 1951

3 Sheets-Sheet 3

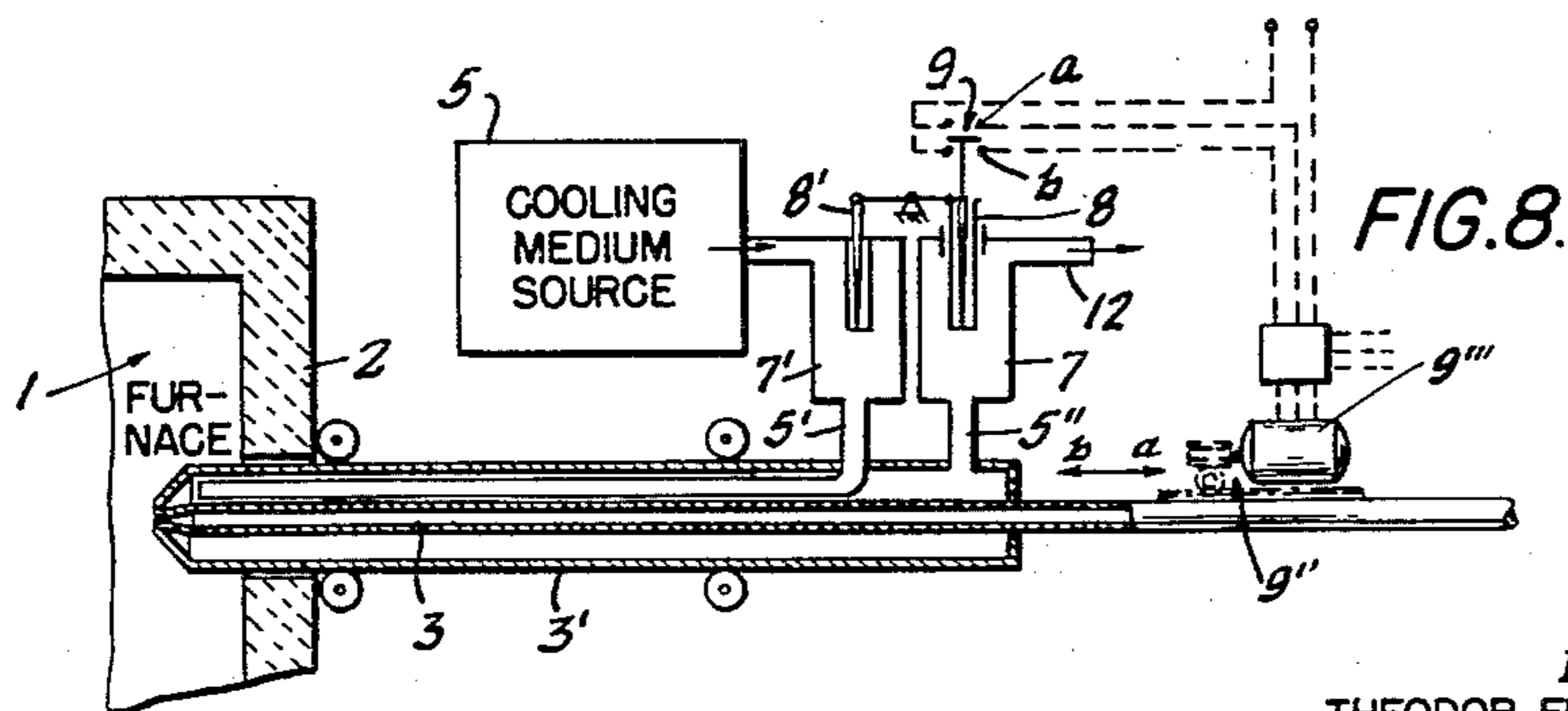
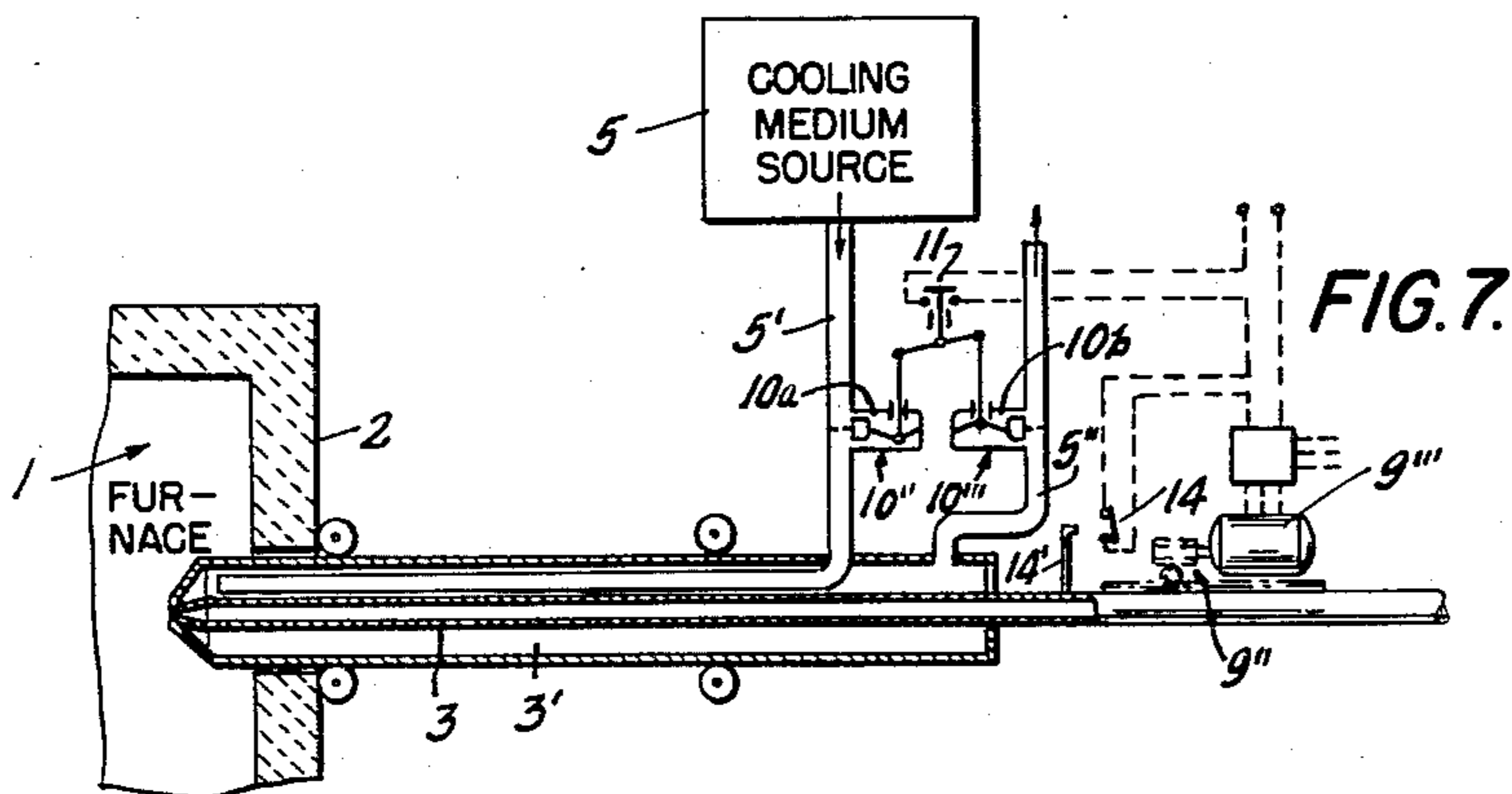
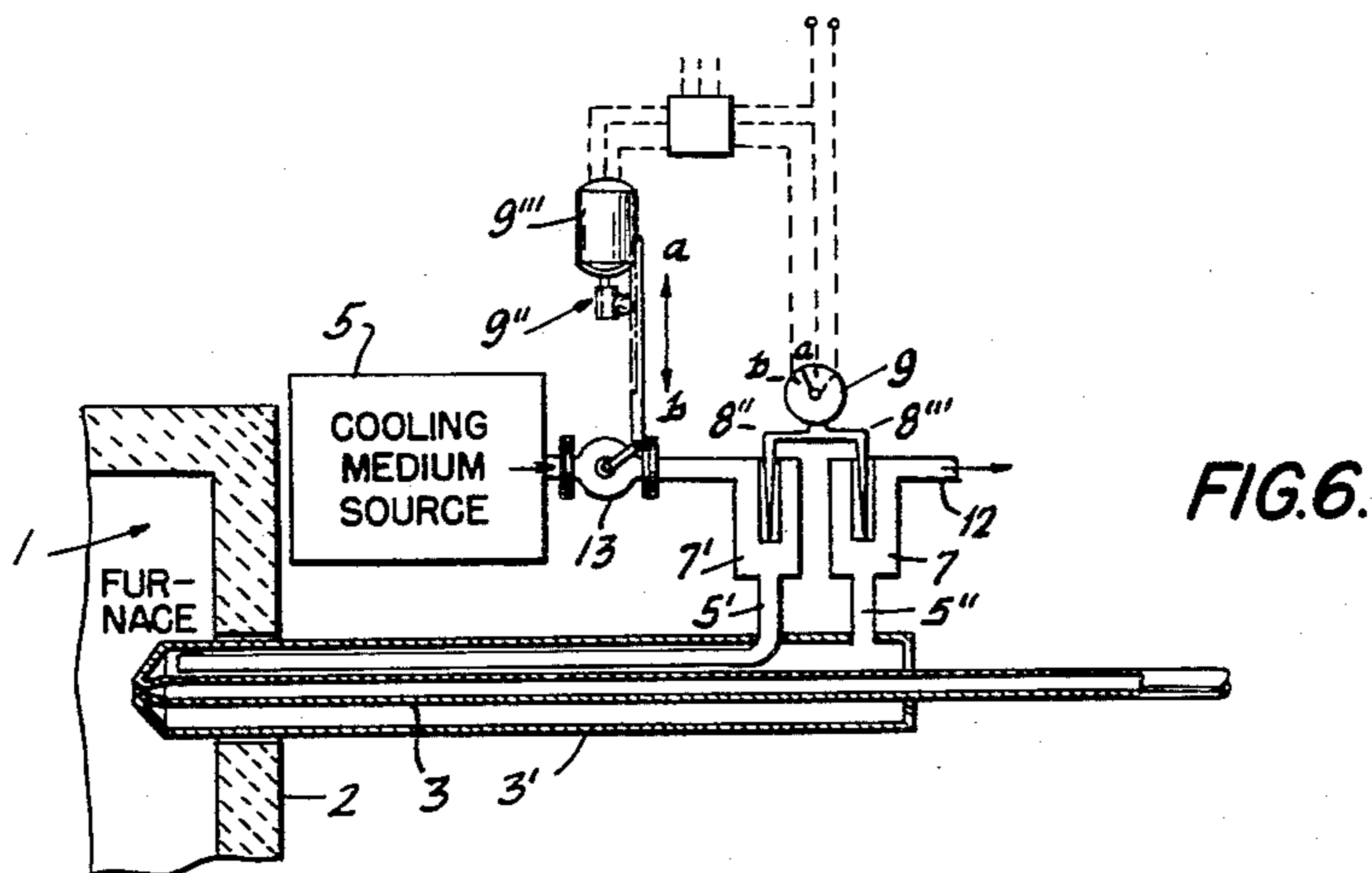

INVENTOR.
THEODOR EDUARD SUESS

BY

Arundel, Free, Graves & Donohue

his ATTORNEYS

1

2,850,325

NOZZLE AND CONTROL ASSEMBLY FOR THE INTRODUCTION OF FLUID MATERIAL INTO A HEATED CHAMBER

Theodor Eduard Suess, Linz-Spallerhof, Austria, assignor, by mesne assignments, to Vereinigte Osteneichische Eisen- und Stahlwerke Aktiengesellschaft, Linz, Austria, an Austrian joint-stock company

Original application January 16, 1951, Serial No. 206,146, now Patent No. 2,794,681, dated June 4, 1957. Divided and this application February 14, 1957, Serial No. 652,645

Claims priority, application Austria January 31, 1950

4 Claims. (Cl. 299—107)

This invention relates to the introduction of materials into the heated interior of devices, such as reaction chambers, furnaces, converters and the like, and it has particular relation to a system and procedure of this type, in which nozzles are used for the introduction of said materials into such devices.

This is a division of the Theodor E. Suess application Serial No. 206,146, filed January 16, 1951, now Patent 2,794,681.

The main object of the present invention is to avoid disturbances caused by leakage or similar defects occurring in the nozzles and parts or elements connected therewith, used in the before mentioned systems or procedures.

It is also an object of the invention to provide means adapted to automatically bring about adjustment of the operation of nozzles used in devices of the before mentioned type, in accordance with differences of the temperatures and/or amounts of cooling fluid supplied to and discharged from the nozzle.

Other objects and the advantages of the invention will be apparent from the following specification and the appended drawing which disclosed by way of example, and without limitation, some embodiments of the invention.

In the use of nozzles for introducing liquid, vaporous or gaseous substances, such as fuel, chemically acting ingredients, gases and the like, into a space of high temperature, for example a reaction chamber, furnace, combustion chamber, converter or the like, the nozzles are usually subjected to cooling by a liquid medium, particularly water, in order to prevent or reduce the harmful effect on the nozzles, of such high temperatures. However, as a result of chemical corrosion or as a result of different thermal expansion of the cooled and not cooled parts of the nozzles, leakage may occur in the nozzles and/or their cooling jacket. Such leakages may cause not only disturbances in the functioning of the nozzles and the processes in which the nozzles are used, but they may even result in the formation of explosive mixtures in the reaction space or the like, into which the nozzles are discharged.

It is in many cases difficult or impossible to find and repair the leaking spots, because, owing to the type of mounting the nozzles in the apparatus used and owing to the presence of flames, smoke and the like in such apparatus, the discharge openings of the nozzles are in most cases not accessible to observation during operation.

It has now been found that the above mentioned defects in nozzles and parts connected therewith, can be easily discovered and the dangers resulting from the defects can be eliminated by constant observation and registration of the temperature and quantity of the cooling medium fed to and discharged from the nozzle.

2

In case of a leakage in the nozzle, the temperature of the discharged cooling liquid rises relatively quickly, while the quantity of the discharged liquid decreases.

According to the present invention, the increase of temperature of the discharged cooling liquid, over the temperature of the cooling liquid supplied to the nozzle and/or the decrease of the amount of the discharged cooling liquid in comparison to the amount supplied to the nozzle are used for controlling the flow of the cooling medium and/or the flow of materials supplied through the nozzles.

In carrying out the invention, devices for measuring said differences of temperature and amounts of cooling liquid, are utilized for the control and/or actuation of alarm devices, throttle means, or shut-off devices and, if desired also of devices for retracting the nozzles from the reaction space or the like.

In measuring the temperature of the cooling fluid, a conventional temperature measuring device may be used, which is provided with adjustable or fixed contacts adjusted to certain predetermined temperatures. As examples of such devices, contact thermometers, resistance thermometers, thermo-electric pyrometers and the like are mentioned. For measuring the quantity of the fed and discharged cooling fluid, conventional liquidmeters can be used, which are also provided with contacts adjustable to predetermined amounts of liquid.

If the temperature of the discharged fluid rises over a certain predetermined limit, and/or the amount of the discharged cooling fluid decreases below a certain predetermined limit, the above correspondingly adjusted contacts will bring about closing of an electric circuit including, if desired a suitable relay, and said electric circuit will then cause actuation of alarm, throttling or shutting off devices acting, for example, on the supply of cooling fluid and/or the supply of material fed through the nozzle.

For a more complete understanding of the invention reference may be had to the accompanying drawings in which:

Fig. 1 diagrammatically illustrates, by way of example and without limitation, the present invention and shows a reaction chamber provided with a nozzle for the introduction of air into said chamber.

Figs. 2 and 3 diagrammatically illustrate alternative arrangements for regulating the volume of working material introduced through the nozzle in accordance with variations in the temperature of the medium for cooling the nozzle;

Fig. 4 illustrates a similar arrangement except that the volume of working material supplied to the nozzle is regulated in accordance with variations in the pressure of the nozzle-cooling medium;

Figs. 5 and 6 respectively illustrate arrangements similar to those of Figs. 4 and 3 except that the corresponding cooling medium pressure- and temperature-responsive means are employed to regulate the volume of cooling medium supplied to the nozzle jacket; and

Figs. 7 and 8 respectively illustrate arrangements similar to those of Figs. 4 and 2 except that the variations in the corresponding pressure or temperature of the nozzle-cooling medium are employed to regulate the position of the nozzle relative to the reaction chamber interior.

Referring to Fig. 1 of the drawing, reference numeral 1 denotes a reaction chamber, in the wall 2 of which nozzle 3 is inserted and serves for the introduction of preheated air into said reaction chamber 1. The source of hot air 4 is connected to nozzle 3 through a valve or other control device 9'. Nozzle 3 is provided with a cooling jacket 3'. The cooling fluid is supplied to jacket 3' through tube 5' and discharged through tube 5''. The

cooling liquid discharged through tube 5'' flows to vessel 7, while the water supplied to the nozzle flows through vessel 7'. Means 8, 8' are provided for measuring the difference between the temperatures of the cooling liquid supplied to and discharged from the cooling jacket of nozzle 3. Said means 8, 8' may be of the aforementioned contact or resistance thermometer or thermoelectric pyrometer types, examples of which are shown in Figs. 2, 3, 6 and 8, to be described, and are connected with an adjustable switching device 9, which, at a predetermined difference between the temperatures of the cooling liquid supplied to and discharged from the cooling jacket of the nozzle, closes an electric circuit, which, in turn, causes actuation of an alarm, throttling or shut-off device 9'. Reference numerals 10, 10' denote means for measuring the difference in the amounts of cooling liquid supplied to and discharged from the cooling jacket of nozzle 3 and may be of the aforementioned liquid meter type, an example of which is shown in Figs. 4, 5 and 7, to be described. Numeral 11 denotes an adjustable switching device which brings about actuation of the above mentioned alarm, throttling or the like device 9', at a predetermined difference between the amounts of the cooling fluid supplied to and discharged from the cooling jacket 3' of nozzle 3. Reference numeral 12 denotes a tube for the final discharge of cooling fluid.

Control systems according to the invention, wherein the difference in temperature of the cooling medium is utilized for controlling the amount of the material introduced through the nozzle 3, are illustrated in Figs. 2 and 3.

In Fig. 2 and in all the other figures, the reaction chamber is designated by 1, the refractory lining by 2, the cooled working material nozzle by 3. The numerals 5' and 5'' denote the tubes for the supply, or discharge, of the cooling medium to and from nozzle jacket 3'. In an extension of the conduit 7' for the supply of the cooling medium there is provided a stationary extension piece 8', and in an extension of the conduit 7 for the discharge of the cooling medium there is provided a thermostatically movable extension piece 8. This piece is connected through a lever with a feeler projecting into the extension piece 8', the feeler provided in 8 being connected with a contact means 9 which, according to a contact being made at *a* or *b*, moves the valve 9' for the supply of working material into the nozzle 3 in the directions *a* or *b* by a rack and pinion combination 9'' actuated by a servomotor 9'''.

A similar device is illustrated in Fig. 3, wherein, instead of the extension pieces 8 and 8', there are provided thermic fluid elements 8'' and 8''' in the extended conduits 7' and 7 for the supply and discharge of the cooling medium to and from cooling jacket 3', the difference in temperature of said elements 8'' and 8''' being indicated by having a movable pointer-contactor adapted to close either contacts *a* or *b*. By movement of the pointer, contacts *a* or *b* are closed, thus energizing motor 9''' to effect through rack and pinion combination 9'' a corresponding movement in the directions *a'* or *b'* of the valve 9' for controlling the supply of the working material to the nozzle 3. There may be provided several contacts like *a* and *b* for effecting a more accurate graduation of the control operation.

A control of the amount of the working material introduced through the nozzle 3, by a change in the amount of the cooling medium supplied or discharged, is illustrated in Fig. 4. Therein numerals 10 and 10' denote a device indicated by the pressure of the cooling medium the amount of the material which has passed through nozzle cooling jacket 3'. In conduits 5' and 5'' for the supply and discharge respectively of the cooling fluid, respective diaphragm plate or piston 10'', 10''' is provided, in front of which and behind which a connection to a corresponding membrane 10*a*, 10*b* is provided. Said membrane 10*a* or 10*b* deflects, according to the pressure

difference in front of and behind the same, and changes its degree of deflection, as soon as there is a change in the amount of the materials passed. Rods leading from the two membranes 10*a* and 10*b* to a lever system are provided, said lever system carrying an electrical contact 11. With a determined amount of the materials supplied, whereby likewise the amount of the materials discharged is determined, provided there are no losses, both membranes 10*a* and 10*b* remain in unchanged position. By means of an adjusting screw the contact 11 is adjusted so as to remain in only open position. As soon as the amount discharged is smaller than the amount supplied, e. g., in consequence of a leakage, the membrane 10*b* changes its shape. Because of the smaller pressure difference it becomes flatter; thereby the contact 11 is moved downwards by the lever system, closes the circuit across contact 11, and thus energizes the motor 9''' actuating the rack 9*a* connected to valve 9' to control the amount of working fluid supplied to nozzle 3. As the valve 9' is thus driven to one or the other extreme position, say to the fully open position, rack 9*a* engages and opens normally closed switch 9*b* to de-energize motor 9'''.

A device whereby the difference in the amount of the cooling medium supplied and discharged to and from jacket 3' is controlled, is illustrated in Fig. 5. The latter shows in a manner similar to that of Fig. 4, that by the contact 11 controlling servomotor 9''' the amount of the cooling medium is increased at the moment in which the amount discharged decreases because of a leakage. The working fluid supply valve 9' is opened by motor 9''' until there is restored a certain pressure difference between the cooling medium supplied and discharged by respective pipes 5' and 5'' to and from nozzle cooling jacket 3', said difference being adjusted in advance by an adjusting screw upon the contact 11. In this manner the detrimental effect of a leakage on the cooling procedure may be compensated to a certain extent.

An arrangement, wherein the amount of the cooling medium supplied to nozzle cooling jacket 3' is controlled by changes of temperature thereof as in Fig. 3, is illustrated in Fig. 6, with the distinction that the servomotor 9''' does not actuate the valve of the nozzle conduit, but the valve 13 of the conduit for supplying the cooling medium.

Devices wherein by a change of temperature in the cooling medium, or a change in the amount of cooling medium, both the cooling medium and the supply of the working fluid to the nozzle 3 are controlled, are combinations of the details of the devices illustrated in Figs. 1 to 6 of the drawings. Similarly, the difference in temperature, or in the amount of the cooling medium supplied and discharged, is used for controlling the supply of the working material to the nozzle conduit 3 or the amount of the cooling medium at the jacket 3', or both.

Devices for withdrawing the nozzle 3, which are controlled by the difference in the amount or by the temperature difference of the cooling medium supplied and discharged to and from jacket 3' are illustrated respectively in Figs. 7 and 8. According to Fig. 7, the servomotor 9''' is put into operation by a contact 11 actuated by the membranes 10*a* and 10*b* in response to pressure on the pistons 10'' and 10''' by the liquid in corresponding conduits 5' and 5'' supplying and discharging the cooling medium to and from jacket 3', as in the arrangement of Fig. 4, except that the servomotor 9''' through rack and pinion combination 9'' bodily retracts the nozzle 3 in response to a significant decrease in the volume of the cooling medium to a point where contact 14 is opened by detent 14' on nozzle 3 to open the circuit of servomotor 9'''.

In Fig. 8 there is illustrated the arrangement of Fig. 2, wherein the differential thermostatic expansion members 8 and 8' effect by means of a lever system the engagement by contact 9 of either the contact *a* or *b*, thus energizing the servomotor 9''' and advancing or retracting the nozzle

3 through rack and pinion combination 9" either toward *a* or *b*.

The means used for measuring the differences of temperatures and quantities of the supplied and discharged cooling fluid and actuating the alarm, throttling, etc. device, are of conventional design and construction. They do not form, per se, part of the present invention and are, therefore, not shown in detail in the drawing.

The present invention can be used in processes and equipments of all kind, in which pulverized liquid, vaporous or gaseous substances are introduced by means of nozzles into reaction chambers, furnaces, converters and the like. The invention is particularly suitable for use in connection with nozzles for the supply of gases, such as air, oxygen and the like or for blowing such gases onto the surface of a bath of molten metal, which may be covered with a layer of molten slag, for example for the refining of molten metals by means of air or oxygen.

As already mentioned above, the present invention may also be used for controlling the amount of the material supplied through the nozzles, for example for reducing the amount of, or shutting off, said materials toward the end of the reaction which takes place in the reaction chamber or the like, in chemical or metallurgical processes. If, at a certain phase of such process, the temperature in the reaction chamber or the like, changes, e. g. increases or decreases, such change will be accompanied by corresponding changes of temperature of cooling liquid discharged from the cooling jacket of the nozzle. If such changes pass certain predetermined limits, corresponding adjustments will be automatically brought about in the above described manner, e. g. the supply of the material fed through the nozzle will be affected by the above described automatically acting devices which are operated in accordance with predetermined differences of temperature of the cooling liquid supplied to and discharged from the nozzles.

It will be understood from the above disclosure that the present invention is not limited to the specific details, steps, etc. described above and illustrated in the drawing and may be carried out with various modifications. For example, instead of closing an electric circuit, actuation of the alarm, throttle and the like devices may be effected by the interruption of an electric circuit. Furthermore, actuation of the automatically operating alarm, throttle and similar devices may be based on measurements of temperature alone or on a combination with measurements of the amounts of the supplied and discharged cooling liquid. These and other modifications may be made by those skilled in the art without departing from the scope of the invention as defined in the appended claims.

The term "nozzle" is used in the present specification and claims to denote discharge means which are applied to the end of tubular conduits and consist of usually tapering tubular elements which may be provided with means for finely dividing the medium supplied through said conduits.

As examples of devices for measuring the amount of cooling fluid supplied to and discharged from the nozzle a ring balance, or a mercurial level, are mentioned.

As examples of devices for withdrawing the nozzle may be mentioned: lifting means with a vertical arrangement of the nozzle, or a carriage supporting the nozzle and movable for instance in horizontal direction.

What is claimed is:

1. A system for the introduction of materials supplied by a nozzle into the heated interior of a device, comprising a nozzle provided with first means through which a cooling medium is passed, further means arranged in contact with the cooling medium supplied to and discharged, respectively, from said first means, for indicating changes of the cooling medium discharged from the nozzle, with reference to the cooling medium supplied to the first means, said indicating means being combined with automatically operated means for causing withdrawal of the nozzle from the heated interior, upon the occurrence of changes of the discharged cooling medium, beyond predetermined limits.

2. A system for the introduction of materials supplied by a nozzle into the heated interior of a device, comprising a nozzle provided with first means through which a cooling medium is passed, further means arranged in contact with a cooling medium supplied to and discharged, respectively, from said first means, for indicating changes of the temperature of the cooling medium discharged from the first means with reference to the cooling medium supplied to the first means, said indicating means being combined with automatically operated means for causing withdrawal of the nozzle from the heated interior upon the occurrence of changes of the discharged cooling medium, beyond predetermined limits.

3. A system for the introduction of materials supplied by a nozzle into the heated interior of a device, comprising a nozzle provided with first means through which a cooling medium is passed, further means arranged in contact with a cooling medium supplied to and discharged, respectively, from said first means, for indicating changes in the amount of the cooling medium discharged from the first means per unit of time, with reference to the cooling medium supplied to the first means, said indicating means being combined with automatically operated means for causing withdrawal of the nozzle from the heated interior upon the occurrence of changes of the discharged cooling medium, beyond predetermined limits.

4. A system for the introduction of materials supplied by a nozzle into the heated interior of a device comprising a nozzle provided with first means through which a cooling medium is passed, further means arranged in contact with the cooling medium supplied to and discharged, respectively, from said first means for detecting changes of the cooling medium discharged from the first means with reference to the cooling medium supplied to the first means, said detecting means being combined with automatically operated means for causing movement of the nozzle relative to said heated interior, upon occurrence of said changes of the discharged cooling medium, beyond predetermined limits.

No references cited.

UNITED STATES PATENT OFFICE
CERTIFICATE OF CORRECTION

Patent No. 2,850,325

September 2, 1958

Theodor Eduard Suess

It is hereby certified that error appears in the above numbered patent requiring correction and that the said Letters Patent should read as corrected below.

In the grant, lines 2 to 4, for "assignor, by mesne assignments, to Vereinigte Osteneichische Eisen- und Stahlwerke Aktiengesellschaft, of Linz, Austria, an Austrian joint-stock company," read -- assignor, by mesne assignments, to Vereinigte Osterreichische Eisen- und Stahlwerke Aktiengesellschaft, of Linz, Austria, an Austrian joint-stock company, --; lines 13 and 14, for "Vereinigte Osteneichische Eisen- und Stahlwerke Aktiengesellschaft, its successors" read -- Vereinigte Osterreichische Eisen- und Stahlwerke Aktiengesellschaft, its successors --; in the heading to the printed specification, lines 5 to 8, for "assignor, by mesne assignments, to Vereinigte Osteneichische Eisen- und Stahlwerke Aktiengesellschaft, Linz, Austria, an Austrian joint-stock company" read -- assignor, by mesne assignments, to Vereinigte Osterreichische Eisen- und Stahlwerke Aktiengesellschaft, Linz, Austria, an Austrian joint-stock company --.

Signed and sealed this 18th day of November 1958.

(SEAL)

Attest:

KARL H. AXLINE

Attesting Officer

ROBERT C. WATSON
Commissioner of Patents