

April 17, 1956

R. W. MURRAY

2,742,555

FLAME BORING APPARATUS

Filed Oct. 3, 1952

2 Sheets-Sheet 1

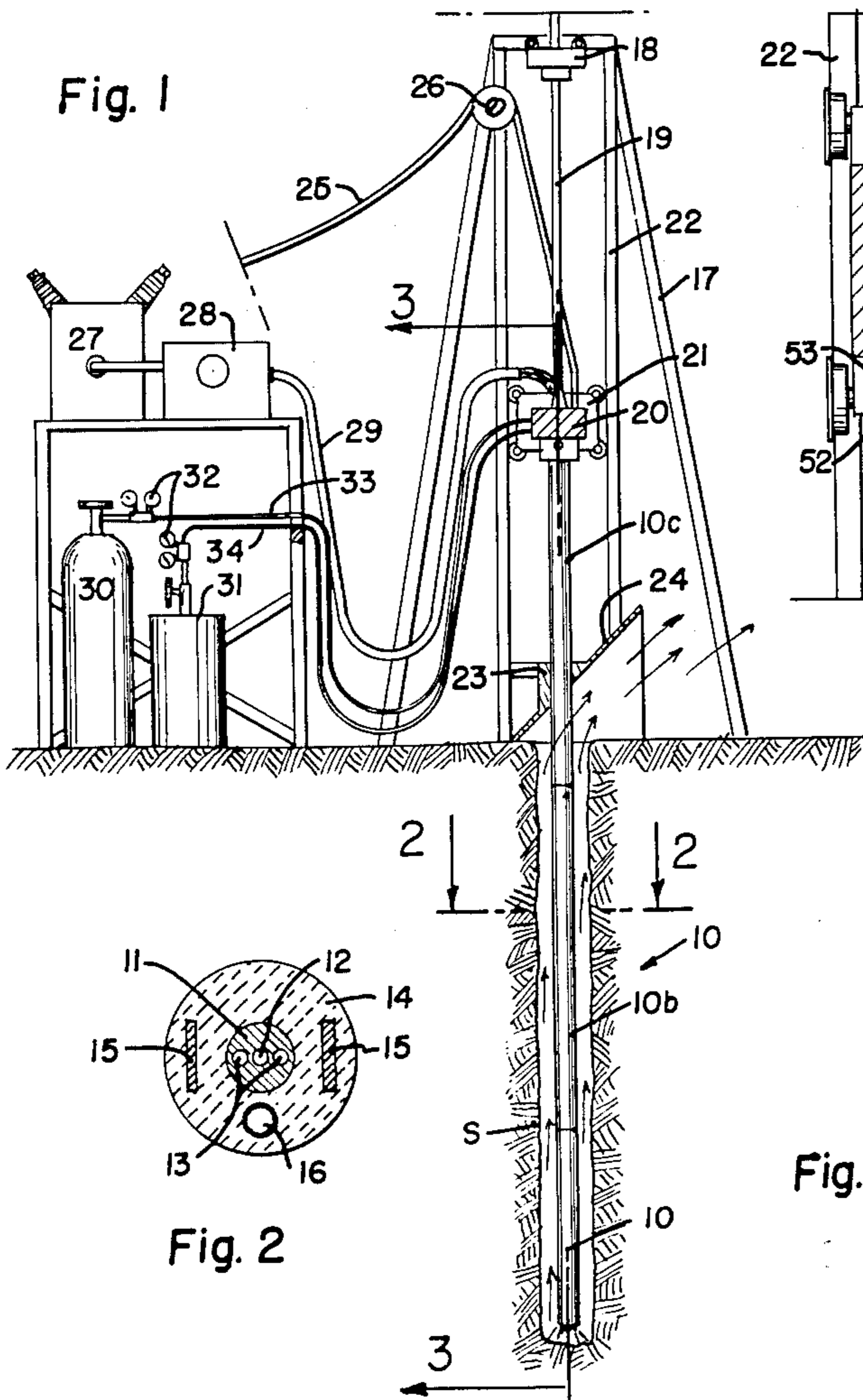

Fig. 1

Fig. 2

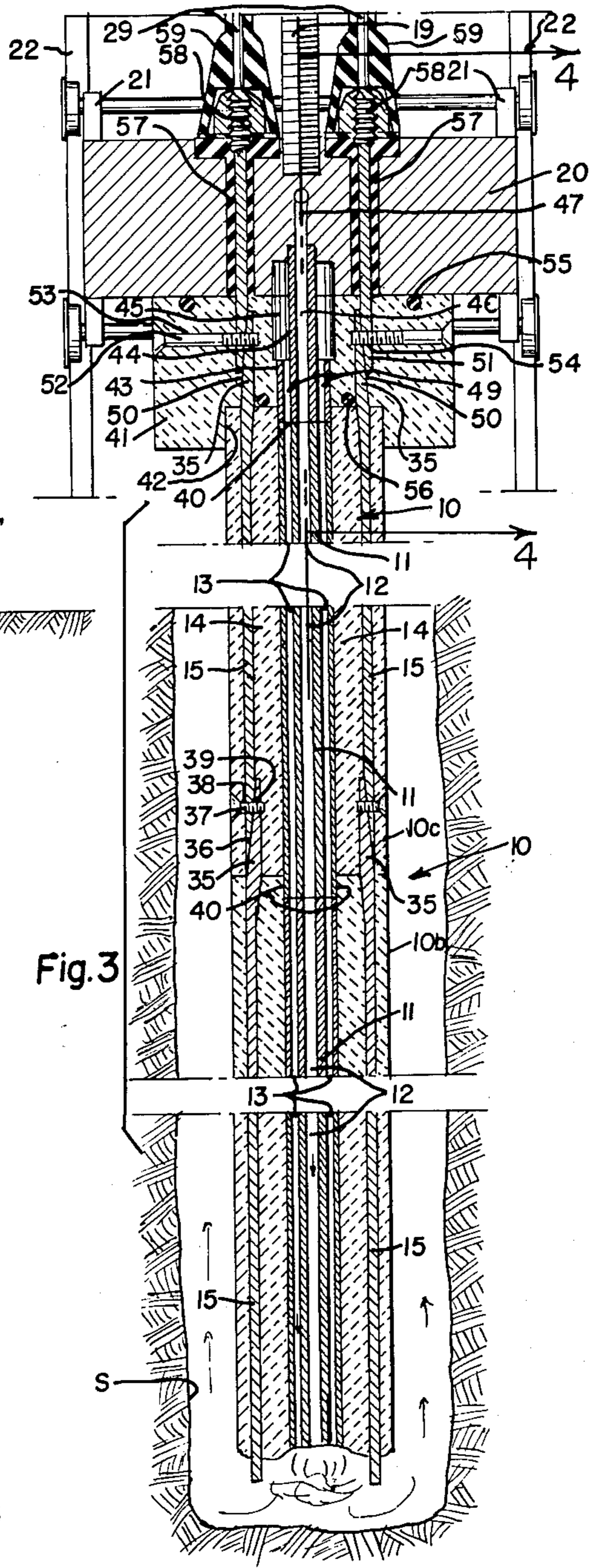

Fig. 3

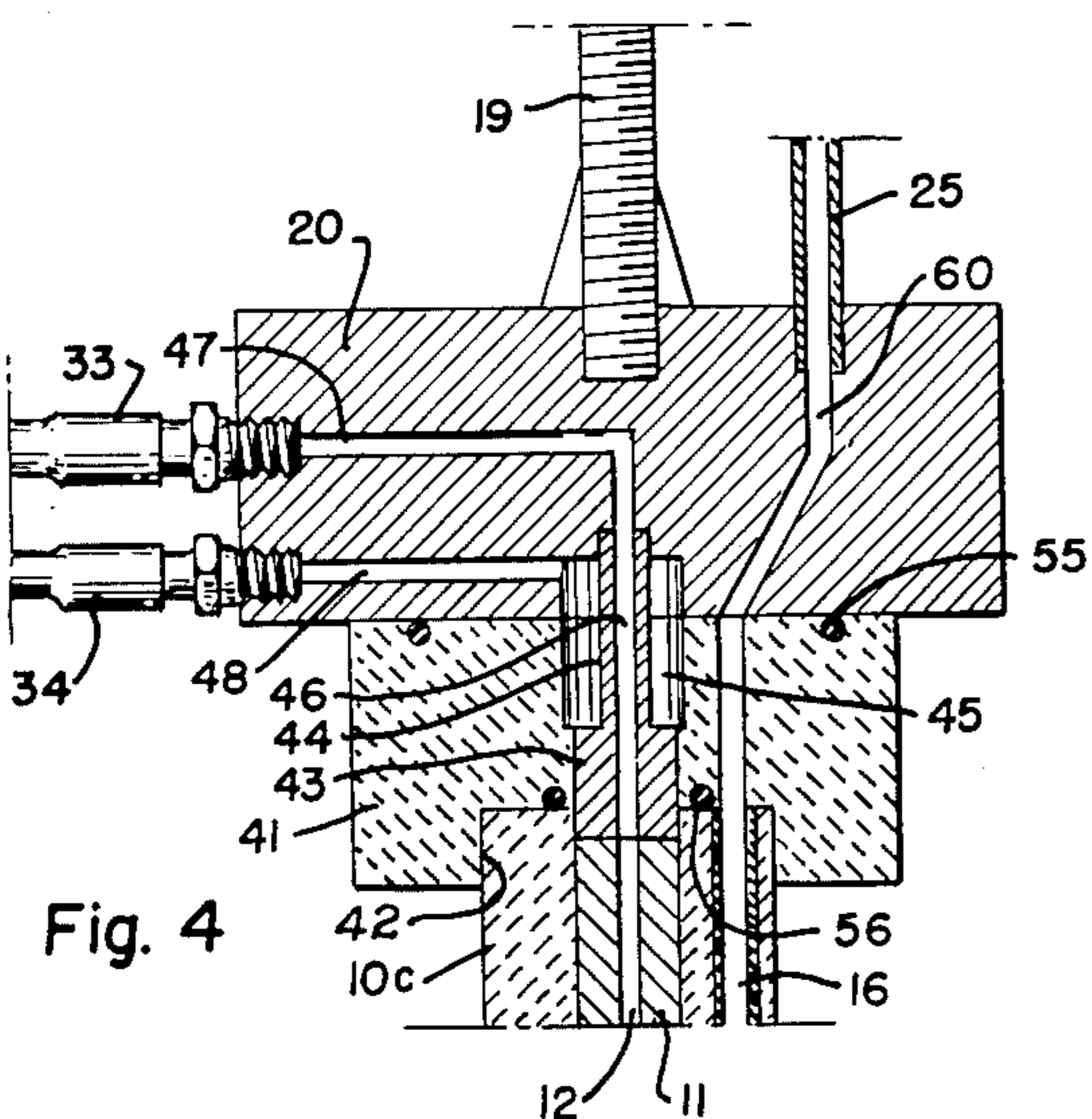

Fig. 4

INVENTOR.
ROBERT W. MURRAY
 BY WHITEHEAD & VOGL
 PER *Earle Whitehead*
 ATTORNEYS

April 17, 1956

R. W. MURRAY
FLAME BORING APPARATUS

2,742,555

Filed Oct. 3, 1952

2 Sheets-Sheet 2

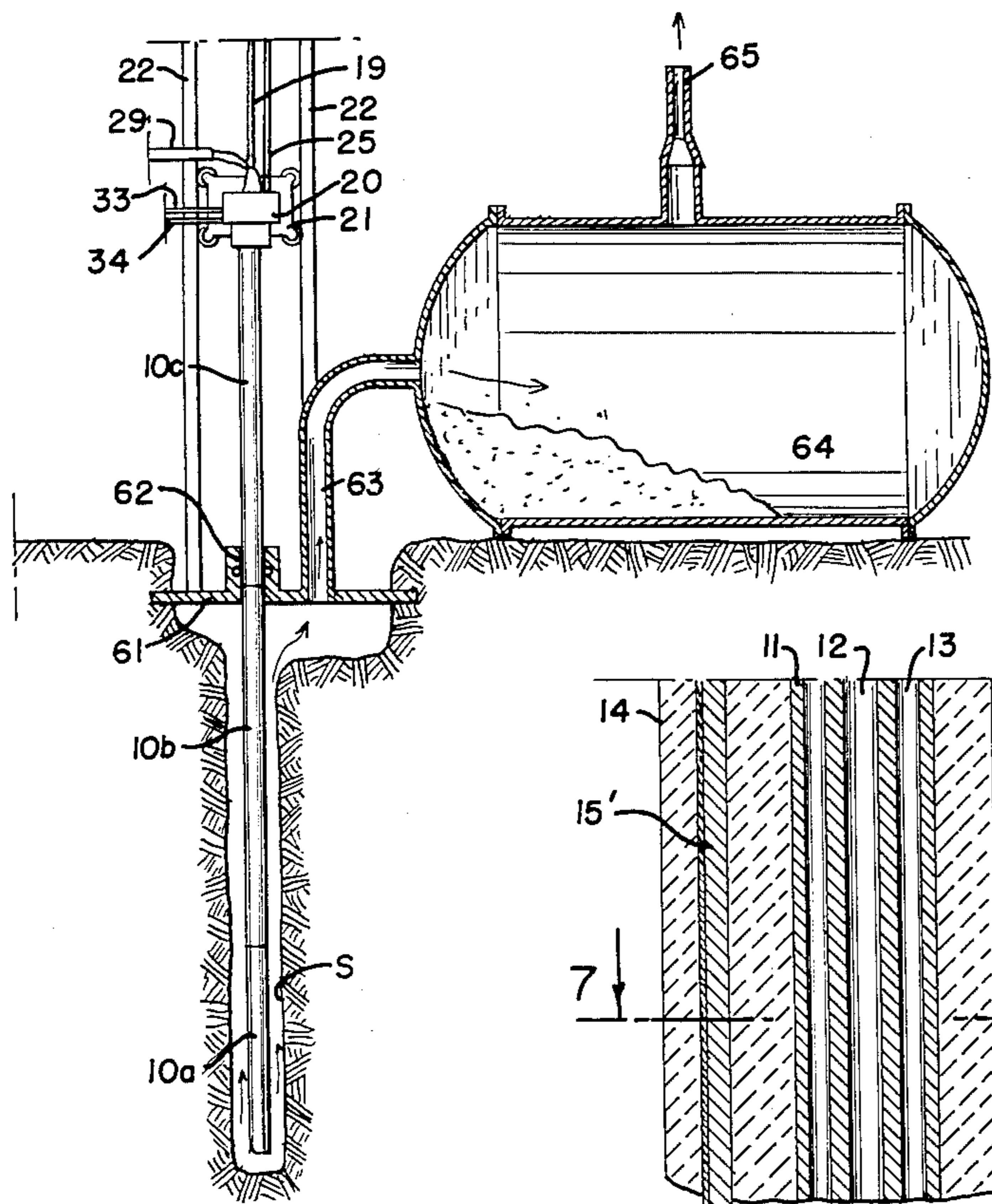

Fig. 5

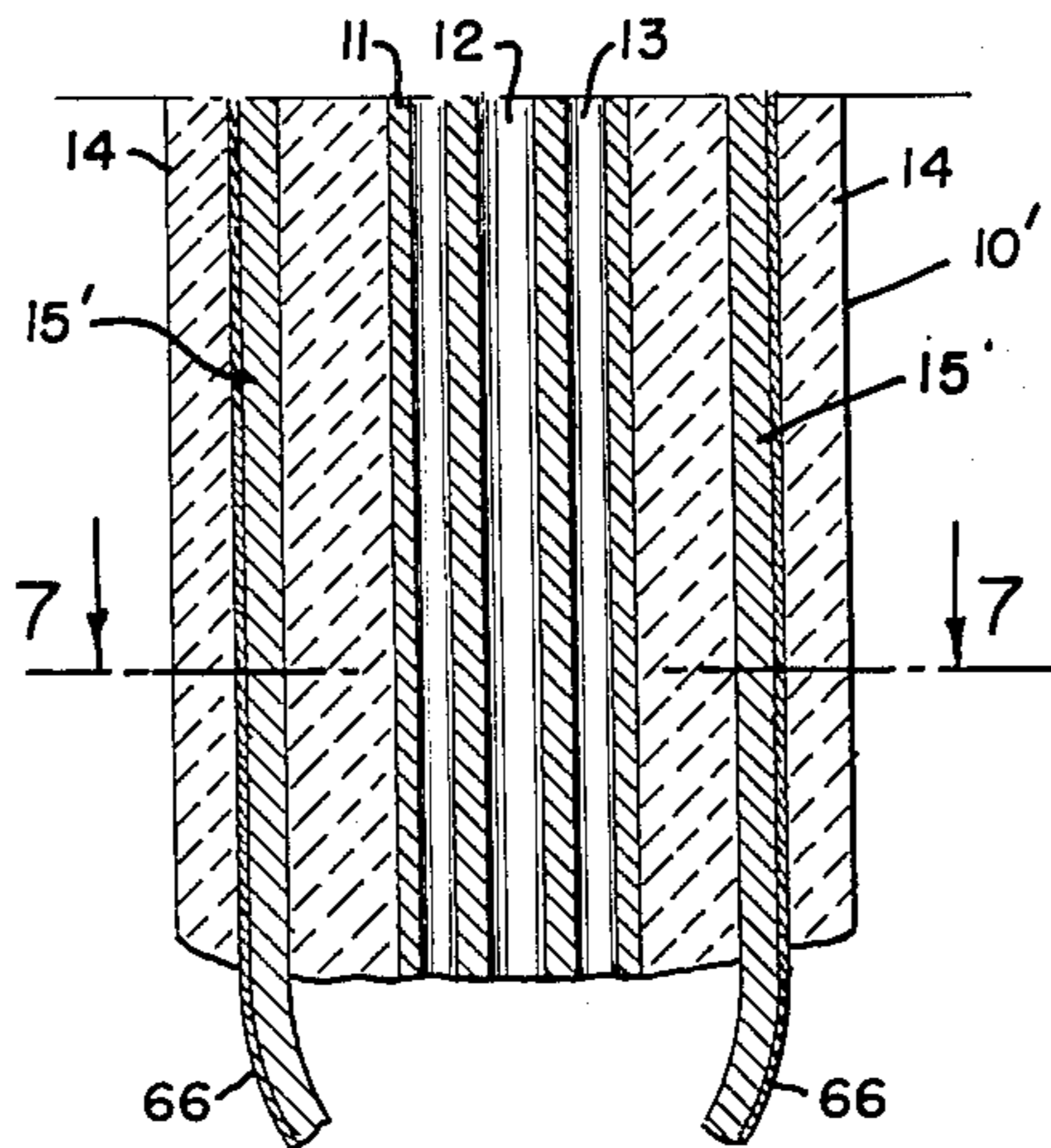

Fig. 6

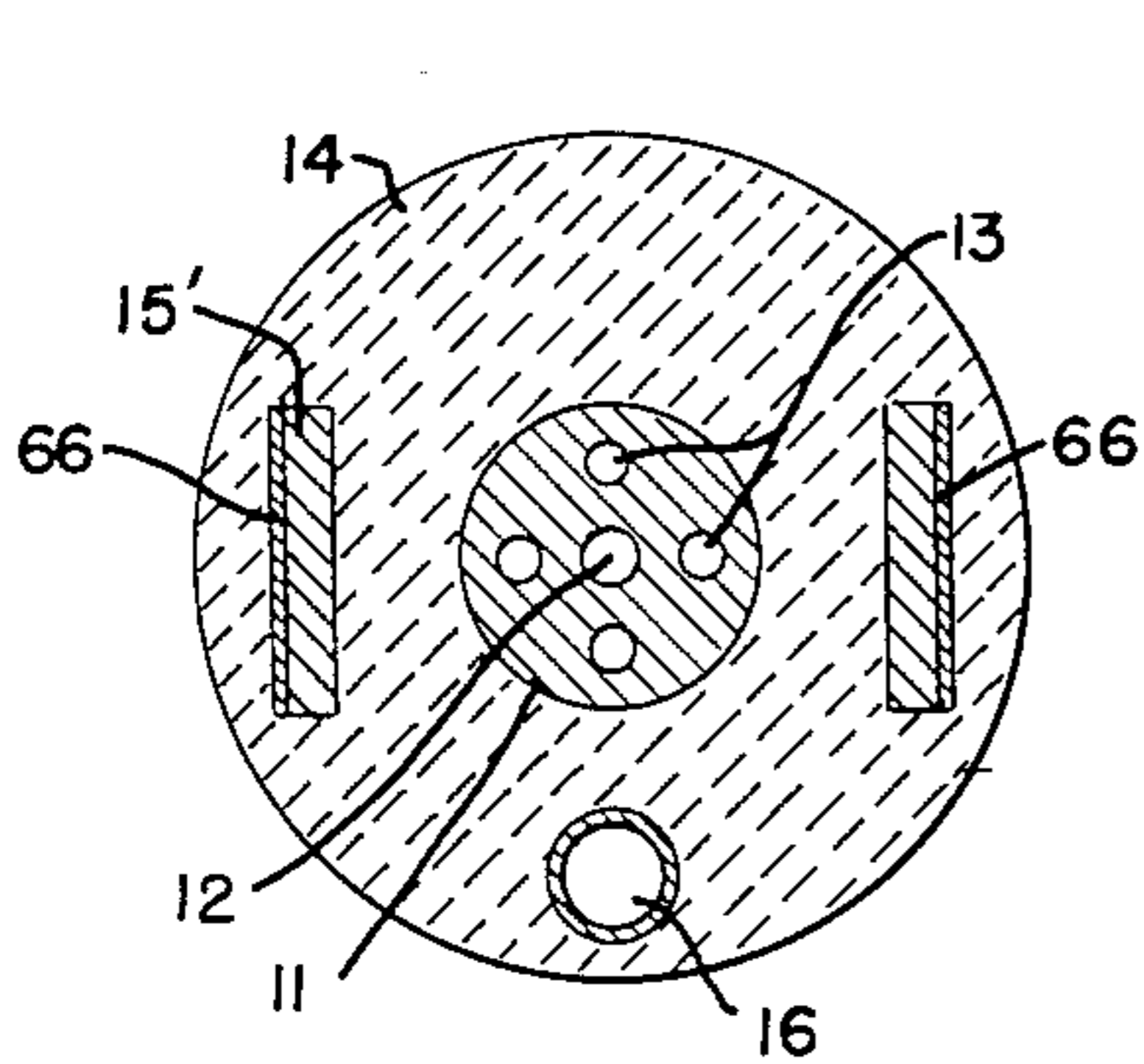

Fig. 7

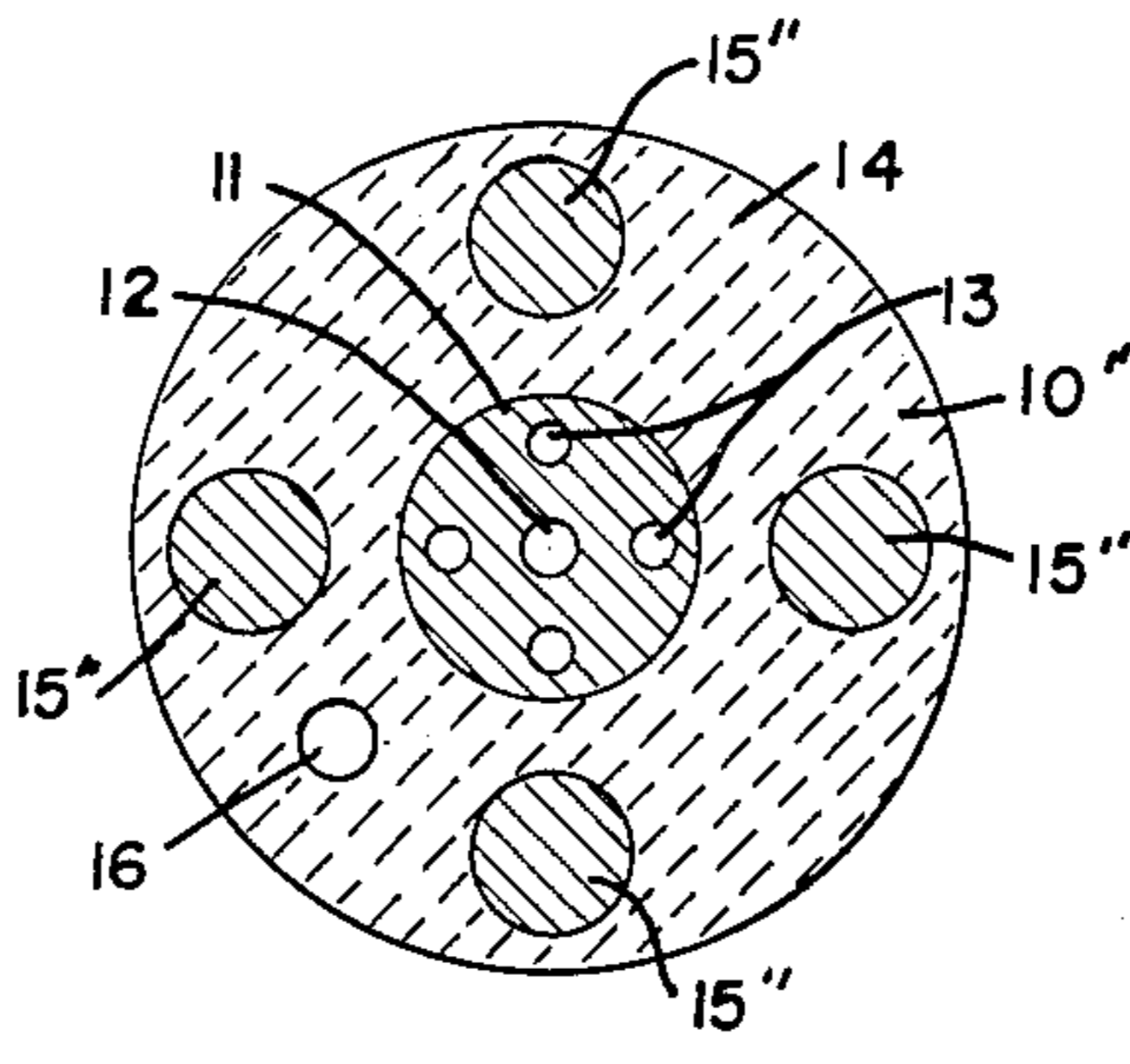

Fig. 8

INVENTOR.
ROBERT W. MURRAY
BY WHITEHEAD & VOGL
PER *Earle Whitehead*
ATTORNEYS

1

2,742,555

FLAME BORING APPARATUS

Robert W. Murray, Denver, Colo.

Application October 3, 1952, Serial No. 312,950

9 Claims. (Cl. 219—14)

This invention relates to flame boring and drilling apparatus of that class which is primarily adapted for drilling into rock, having as an object the provision of a new and improved flame boring apparatus which combines a gas flame with an electric arc.

Other objects of this invention are to provide an improved flame boring apparatus which combines a gas flame with an electric arc and which: (a) is adapted to produce such intense heat that the operation of the flame boring into a rock may proceed at a rapid rate; (b) ionizes the intensely hot gases to facilitate chemical reactions with certain constituents of the rock and thereby accelerates the boring operations; (c) provides means for supplying water or other liquid to the heating area to thereby cool the drill stem, to thereby form a steam blast to remove particles from the bore, to thereby react chemically with rock constituents and to thereby suddenly cool and disintegrate and scintillate heated and molten substances as minute particles; (d) includes an improved drill stem construction adapted for extension by interconnection with additional lengths of stem during a drilling operation; (e) includes improved arcing means comprising electrodes adapted to move together as the arc commences; and (f) is a simply constructed, easily operable apparatus adapted to rapidly and efficiently bore a hole into any type of rock.

With the foregoing and other objects in view, all of which more fully hereinafter appear, my invention comprises certain new and novel constructions, combinations and arrangements of parts and elements as hereinafter described and defined in the appended claims and illustrated, in preferred embodiment, in the accompanying drawing, in which:

Figure 1 is a diagrammatic elevation view of my improved flame boring apparatus carried upon a derrick and positioned for drilling a vertical hole into a body of rock.

Figure 2 is a transverse section through the drill stem as viewed from the indicated line 2—2 at Fig. 1, but on an enlarged scale.

Figure 3 is a sectional elevation of the drill stem as viewed from the indicated line 3—3 at Fig. 1, but on an enlarged scale and with portions broken away to conserve space.

Figure 4 is a fragmentary section of the head carrying the drill stem, as viewed from the indicated line 4—4 at Fig. 3.

Figure 5 is a diagrammatic elevation similar to Fig. 1, but showing an alternate construction wherein the boring operation is in a confined pressurized space.

Figure 6 is a sectional detail of the leading end of an alternate construction of the drill stem on an enlarged scale.

Figure 7 is a transverse section as viewed from the indicated line 7—7 at Fig. 6.

Figure 8 is a section similar to Fig. 7, but showing an alternate construction of the conductor elements for creating an electric arc covering the leading face of the drill stem.

2

One conventional apparatus for flame boring into rock is simply an iron pipe through which a combustible mixture of gas is passed to the leading end of the pipe. The gas, which is primarily oxygen, burns into the rock and also burns away the end of the iron pipe to produce an intensely hot flame, by the reaction of the oxygen with the iron. The heat is sufficient to melt the rock and to permit it to flow from the hole as the burning operation proceeds. The conventional types of flame boring apparatus have definite limitations. For example, this and other conventional types are expensive to operate because of the large quantities of gases which are used and because the iron pipe burns up rapidly or the intensity of the heat must be undesirably restricted.

It has long been recognized that if it were not for such limitations, a flame boring apparatus for boring holes into rock would be very desirable because of the speed at which such an operation can proceed. With the foregoing in view, the present invention was conceived and developed, and comprises, in essence, an apparatus for flame boring which uses a drill stem 10 formed with a tubular core 11 having within it a passageway 12 for oxygen and passageways 13 for a fuel gas. This core is enclosed by a refractory type insulating sheath 14 into which is embedded electrical conduits 15 and a passageway 16 for water. The operation of my improved drill stem, by apparatus hereinafter described, includes flowing oxygen and fuel gas through passageways 12 and 13 to the leading end of the stem 10, forming an electric arc across the leading ends of conduits 15 and flowing sufficient water through the passageway 16 to provide a desired amount of cooling and steam for the ejection of particles as the drilling operation proceeds.

With this arrangement of elements, the action of the arc, combined with burning gases, creates an extremely high temperature which is sufficient to melt and vaporize practically any known substance. Nevertheless, the movement of water through the passageway 16 keeps the leading end of the drill stem sufficiently cool so that it is not burned away at such a rapid rate that the boring operation becomes inefficient because of the cost of replacing drill stems. As the water is ejected from the drill stem, it is vaporized into steam, and in combination with the gases resulting from combustion, creates a blast which removes particles from the hole being drilled.

The amount of water used during a boring operation and the manner in which it is used will depend upon the type of rock encountered. A rock such as limestone which will calcine by the action of heat can be bored at a relatively low temperature and the blast will remove the calcined dust from the shaft. A rock such as granite will require a more intense heat sufficient to disintegrate spall and separate the crystalline particles of felspar and quartz by differential expansion, and it may be even necessary to melt some of the substances constituting the rock. When boring a rock such as quartz, still more intense heat must be used to melt the quartz and it is desirable that the water be intermittently forcibly ejected from the drill to atomize or break up and disintegrate the mass and scintillate the particles into a dust by sudden cooling.

The apparatus shown at Fig. 1 is mounted in a derrick 17, which may be of any conventional construction, having a hoist 18 at its top operable to raise or lower a lead screw 19 at any selected rate by controls not shown herein. The lead screw 19 carries a connector head 20 to which the drill stem 10 is attached in a manner herein described. The connector head is mounted within a wheeled carriage 21 which is confined within vertical guides 22 of the derrick 17.

This derrick is mounted in position for drilling a hole

3

S with the stem 10 depending from the head 20 in line with the hole axis. This stem extends through an orificed guide sleeve 23 which is mounted between the guides 22 at the bottom of the derrick, and this sleeve includes a deflector plate 24, which is adapted to deflect the exhaust gases and particles ejected from the hole S in a selected lateral direction during the drilling operation.

The accessory equipment essential to the operation of the apparatus includes a water supply tube 25 which may be hung from the derrick 17 as over a pulley 26. Conventional valve or regulation means, not herein shown are interposed in this line 25 to regulate the flow of water to the stem. Electrical power may be supplied through a conventional transformer 27 to a voltage regulator 28 having a lead 29 for connection with electrical conduits 15 within the drill stem. The oxygen and fuel gas are supplied from tanks 30 and 31 respectively, which include suitable pressure regulating and control valves as indicated at 32. The respective lines 33 and 34 from the oxygen and fuel tanks, the lead 29 and the water line 25 are all connected into the head 20 for connection with passageways and conduits within the drill stem 10.

The drill stem 10 is formed as a plurality of interconnected sections, such as indicated at 10a, 10b and 10c at Fig. 1, to permit it to be extended for drilling to any desired depth. These sections are joined together in any conventional manner which will permit the electrical conduits 15 and passageways 12, 13 and 16 of one drill stem section to contact and register with the corresponding conduits and passageways of the adjacent section to provide continuity of conduits and passageways throughout the stem.

In the drawing the drill stem sections are shown as joined together by using the electrical conduits 15 as a fastening means. This is possible where the conduits are made of metal or a material having a comparatively high tensile strength. Both of the electrical conduits 15 extend from the top of a section 10 to form tapered dowels 35 and corresponding tapered sockets 36 are formed in the bottom of each section. The dowels 35 at the top of one section 10 are simply inserted into the sockets 36 at the bottom of an adjacent upper section and they are locked into position by screws 37 which are inserted into orifices 38 in the wall of the upper section 10 opposite the sockets 36 and into threaded orifices 39 through the dowels 35. To provide a better seal at the joint where two sections 10 are interconnected and to avoid gas leakage, the core 11 of the upper section 10 extends below the bottom of the sheath 14 and into a socket 40 at the top of the lower section which is formed by terminating its core 11 below the top of the sheath 14.

The head 20 is the focus of the apparatus, for it is the point of interconnection of the drill stem 10 with the hoist lead screw 19, the water supply line 25, the gas lines 33 and 34 and the electrical lead 29. This head is divided into two portions, the upper portion being a rectangular block forming part of the carriage 21 and being attached to the lead screw 19. The lower portion is a collar 41 formed of an insulating type of material which includes a socket 42 at its underside into which the top of the drill stem 10 is inserted for connection thereto. A short cylindrical core 43, concentric with the socket 42, extends through the collar 41 and into the socket 42, the extended portion being adapted to fit into the socket 40 at the top of the drill stem 10 and against the end of the core 11. The top of the core 43 is narrowed to a central stem 44 which is within a chamber 45 in the upper portion of the collar 41 and lower portion of the head 20. A passageway 46 extends through the core 43 and stem 44 to register with the central passageway 12 of the drill stem and a passageway 47 in the head 20. The oxygen line 33 is connected in the head 20 to the passageway 47 whereby the flow of oxygen from the line 33 is through passageway 47 and to pas-

4

sageway 12 of the stem. A passageway 48 extends through the head 20 and to the chamber 45, and the fuel gas line 34 is connected in the head 20 to this passageway 48. Passageways 49 extend from the chamber 45 through the core 43 to register with passageways 13 of the stem 10. The flow of fuel gas from line 34 is thus through the passageway 48 to the chamber 45, through passageways 49 and to the passageways 13 of the drill stem 10.

The collar 41 has openings 50 which are adapted to receive the upstanding dowels 35 at the top of the drill stem and to receive fingers 51 which depend from the head 20 for contact with and engagement to the dowels 35. The engagement is secured by lock screws 52 which are mounted in orifices 53, in each side of the collar, and which extend through orifices 54 of fingers 51 and orifices 39 of the dowels 35. In this manner the head 20, the collar 41 and the drill stem 10 are interconnected.

Gas-tight seals are made between the surfaces of the head 20 and collar 41 and between the collar and drill stem 10 by suitable ring gaskets 55 and 56 respectively.

The fingers 51, connecting with the dowels 35, are electrical conduits which extend through the head 20 within an insulating sheath 57 and terminate at their upper end as threaded studs 58 to which the electrical leads 29 are connected. The connection of each electrical lead 29 is suitably enclosed within an insulating cap 59.

The water supply line 25 is connected to the head 20 in a passageway 60 which extends through the head 20 and through the collar 41 to a point of registration with the passageway 16.

The apparatus may be modified in several ways. The construction illustrated at Fig. 5 shows the drilled hole S enclosed at its top by a diaphragm 61 which includes an orifice 62 through which the stem may extend. The space within the hole is thereby enclosed for operation and burning under pressure. A tube 63 extends from the diaphragm 61 to a tank 64 which has a restricted discharge orifice 65 in its top. The flow of gas from the hole S is thus through the tube 63 into the tank 64 and thence from the orifice 65. The orifice is sufficiently restricted to create an increased pressure within the shaft and within the tank, yet to permit a flow of gas of sufficient velocity that the particles which are scavenged from the hole are moved by the flow of gas into the tank. With such an arrangement, a control of temperature is possible.

Figs. 5, 6 and 7 illustrate bi-metallic electrical conduits 15' formed with an exterior layer of metal 66, the layers on the respective conduits having different thermal coefficients of expansion, whereby the heating of the conduits at the bottom of the drilled hole causes them to coincidentally move toward each other to restrict the burning to the ends of the electrodes, as clearly illustrated at Fig. 6.

Figure 8 shows an alternate construction of a drill stem having four electrical conduits 15'' (although any suitable number may be used), positioned around the core 11. It is contemplated that several electrical currents can be passed through these conduits to create arcs between the various conduits 15'' and form a composite arc which covers the leading face of the drill stem 10 and provides an intensely hot flame.

While I have illustrated and described many details of construction, alternatives and equivalents will occur to those skilled in the art which are within the scope and spirit of my invention; hence it is my desire that my protection be not limited to the details herein illustrated and described, but only by the proper scope of the appended claims.

I claim:

1. A gas-arc flame-boring apparatus including, in combination, a drill stem having passageways in the center of the stem and electrical conduits at opposite sides of the passageways longitudinally throughout its length, a head carrying said stem, and adapted to move an end of

5

the stem at a selected rate into a hole during a boring operation, means for supplying a combustible mixture of gas to the head, passageways in the head connecting the gas supplying means with said passageways in the stem leading to said stem end, means for supplying electrical power to the head and means within the head connecting said power supplying means with the conduits in the stem whereby to form an electric arc at the end of the stem and to ignite and combine with gas emitted from said passageways between the electrical conduits.

2. The flame-boring apparatus defined in claim 1 including means for supplying water to the head and through a passageway in the stem.

3. The flame-boring apparatus defined in claim 1 including a deflector plate inclinedly carried upon the stem near the head whereby to deflect gas and detritus from blowback as the apparatus is drilling a hole.

4. A drill stem for flame-boring apparatus comprising a plurality of sections, each having a core with longitudinal passageways therethrough and an insulating refractory sheath surrounding the core and electrical conduits embedded within the sheath, and means for interconnecting said sections with the core-passageways and conduits of each section connected with and forming continuations, respectively, of the core-passageways and conduits of the adjacent section.

5. The stem defined in claim 4 wherein said connecting means comprise dowels at the tops of the sections and dowel receiving sockets at the bottoms of the sections.

6. The stem defined in claim 5 wherein said dowels are extensions of the electrical conduits and said sockets are within the electrical conduits.

6

7. The stem defined in claim 6 wherein said core extends below the bottom edge of the sheath at the bottom of each section and terminates below the top edge of the sheath at the top of each section.

8. A gas-arc flame boring apparatus, including, in combination, a drill stem having a passageway extending longitudinally therethrough, a pair of electrical conduits extending longitudinally along the stem, said stem including a refractory type insulating material electrically separating said conduits along the stem, said conduits being spacially separated to permit the formation of an arc at one end of the stem and a head at the other end of the stem having connection means for the connection of a gas supply thereto in communication with said stem passageway and having terminal means for the connection of power supply leads thereto in circuit with said electrical conduits.

9. The apparatus defined in claim 8, wherein said stem includes a sheath of refractory type insulating material surrounding the gas passageway and said conduits are embedded in the sheath.

References Cited in the file of this patent

UNITED STATES PATENTS

1,371,094	Holslag	Mar. 8, 1921
1,847,864	Cross	Mar. 1, 1932
1,898,926	Aarts et al.	Feb. 21, 1933
1,927,135	Sammons	Sept. 19, 1933
2,398,427	Hediger	Apr. 16, 1946
2,441,319	Harding	May 11, 1948
2,471,695	McCullough	May 31, 1949