

Jan. 17, 1956

A. W. NELSON
APPARATUS FOR AUTOMATICALLY VACUUM COATING
OF INTERIOR OF GLASS TUBES WITH METAL

2,730,987

Filed March 25, 1954

4 Sheets-Sheet 1

FIG. 1.

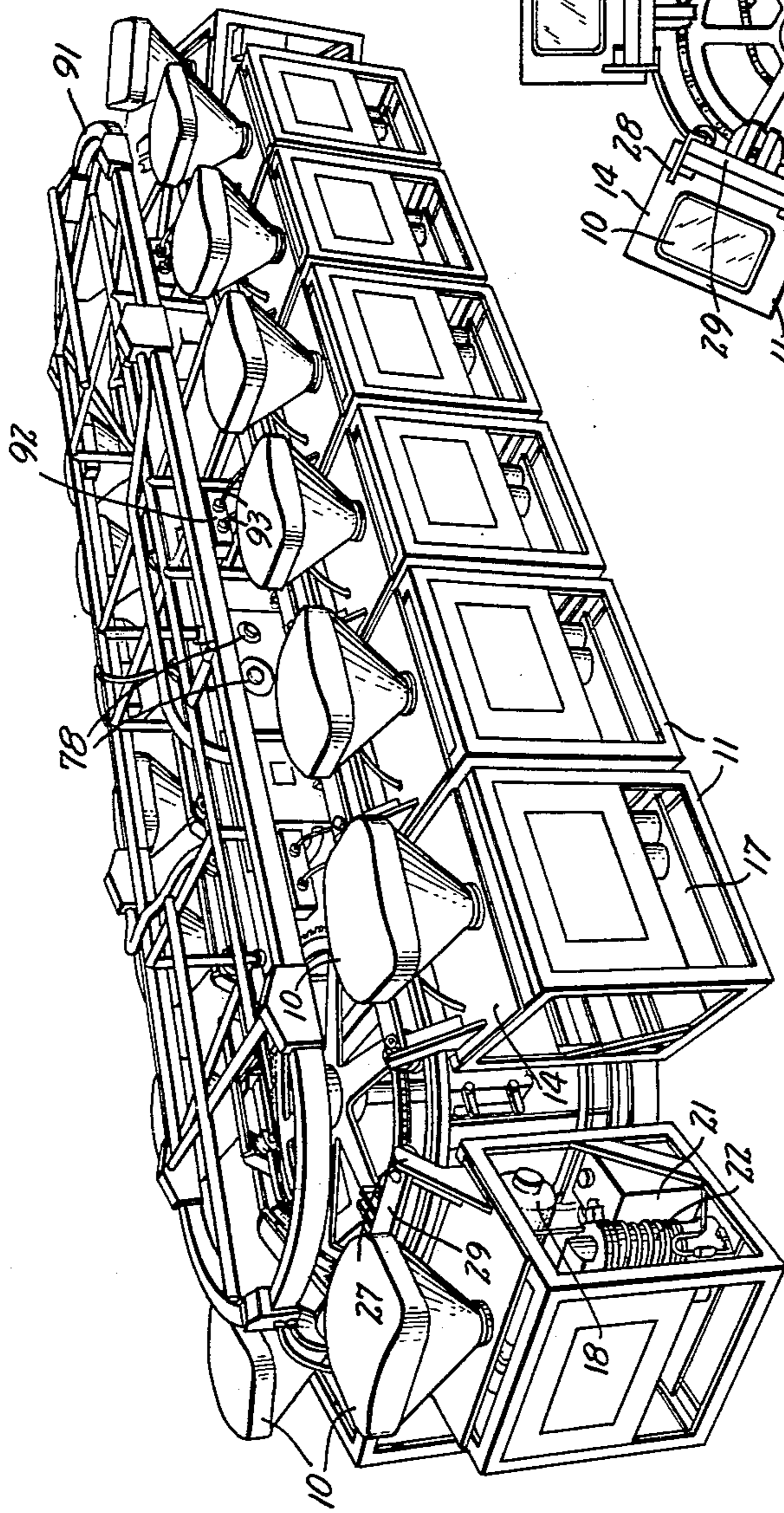
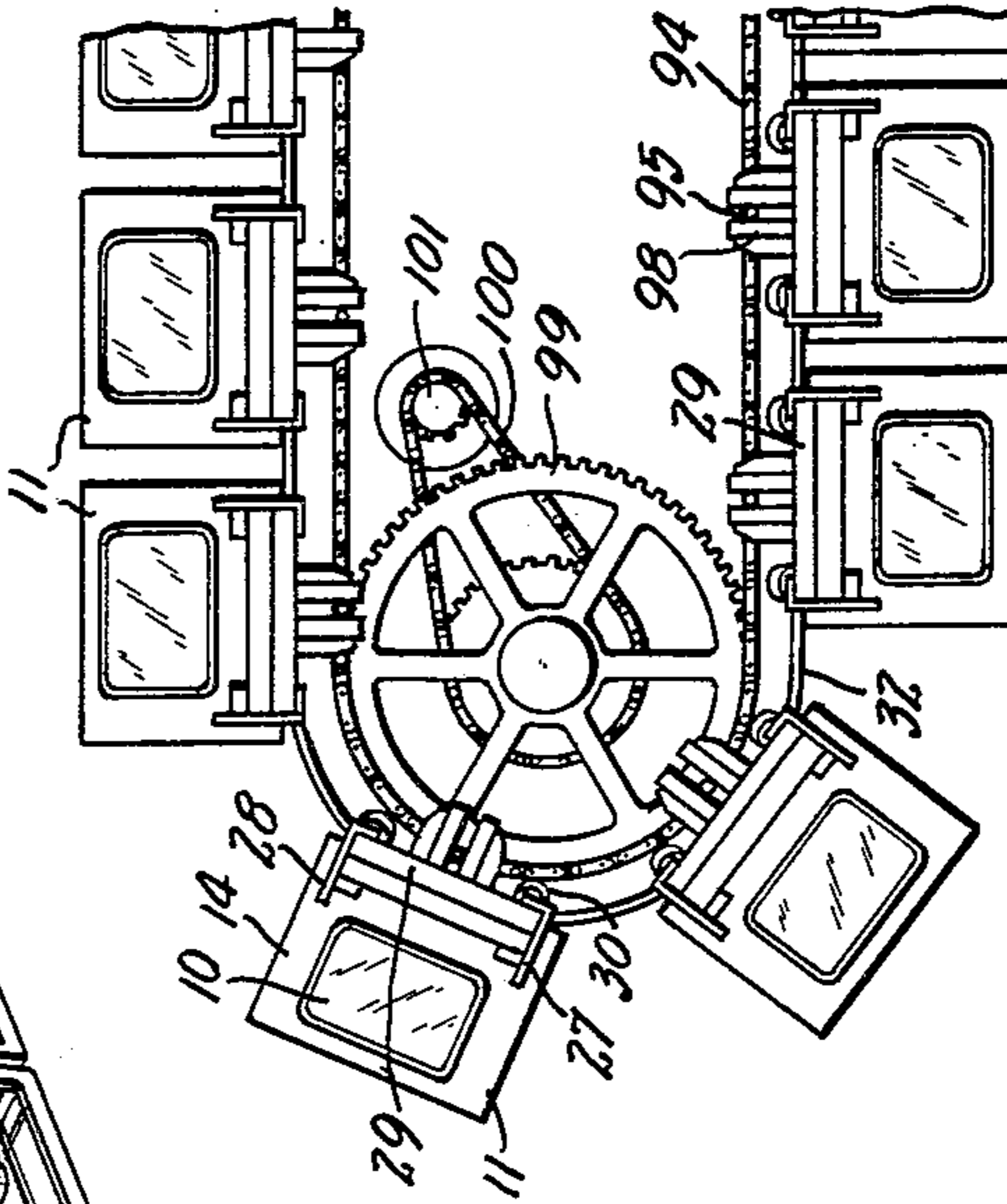

FIG. 2.



INVENTOR
ALDEN W. NELSON
BY *A. W. Nelson*
ATTORNEY

Jan. 17, 1956

A. W. NELSON
APPARATUS FOR AUTOMATICALLY VACUUM COATING
OF INTERIOR OF GLASS TUBES WITH METAL

2,730,987

Filed March 25, 1954

4 Sheets-Sheet 2

FIG. 3.

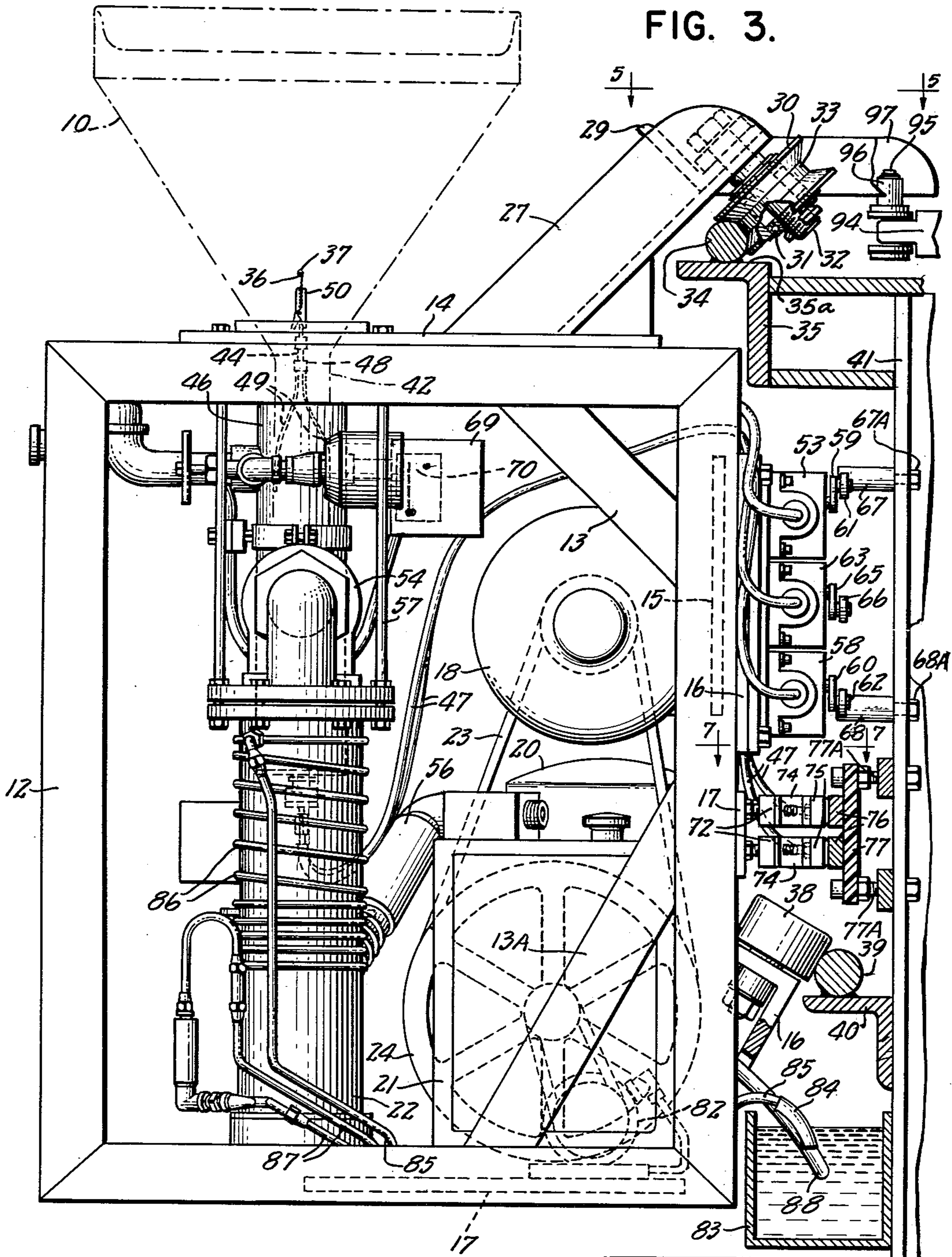

INVENTOR
ALDEN W. NELSON
BY *A. W. Nelson*
ATTORNEY

Jan. 17, 1956

A. W. NELSON
APPARATUS FOR AUTOMATICALLY VACUUM COATING
OF INTERIOR OF GLASS TUBES WITH METAL

2,730,987

Filed March 25, 1954

4 Sheets-Sheet 3

FIG. 4.

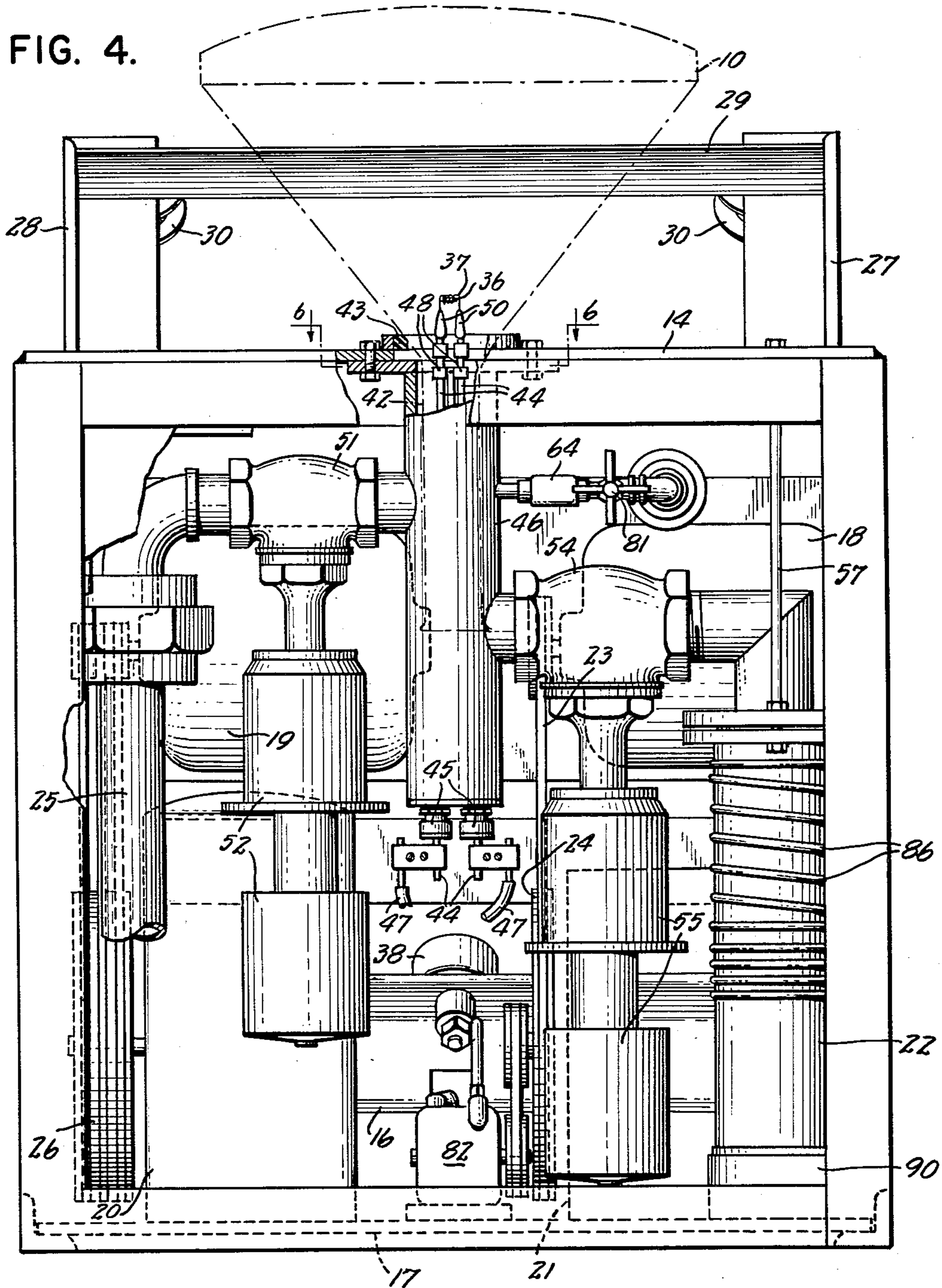

INVENTOR
ALDEN W. NELSON
BY *Alden W. Nelson*
ATTORNEY

Jan. 17, 1956

A. W. NELSON
APPARATUS FOR AUTOMATICALLY VACUUM COATING
OF INTERIOR OF GLASS TUBES WITH METAL

2,730,987

Filed March 25, 1954

4 Sheets-Sheet 4

FIG. 5.

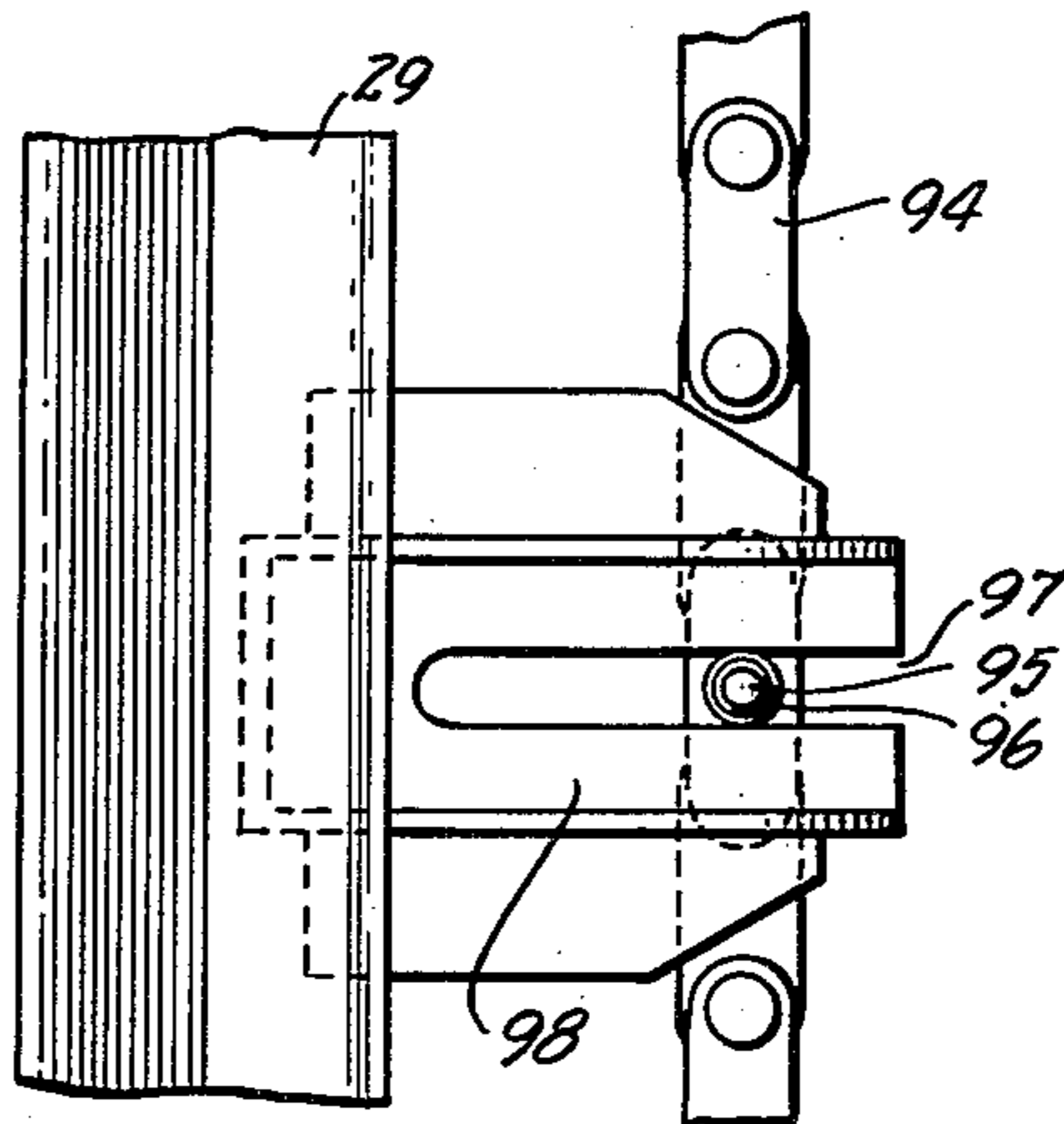

FIG. 6.

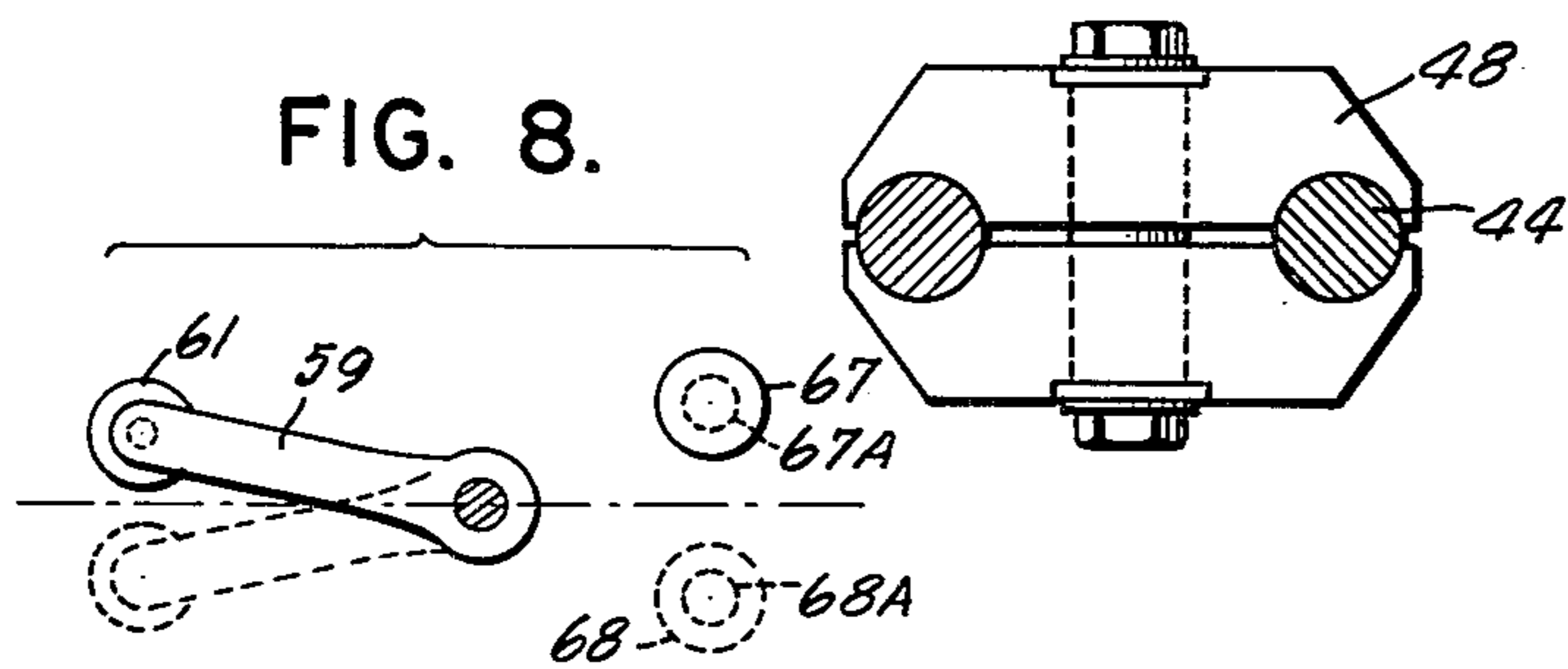
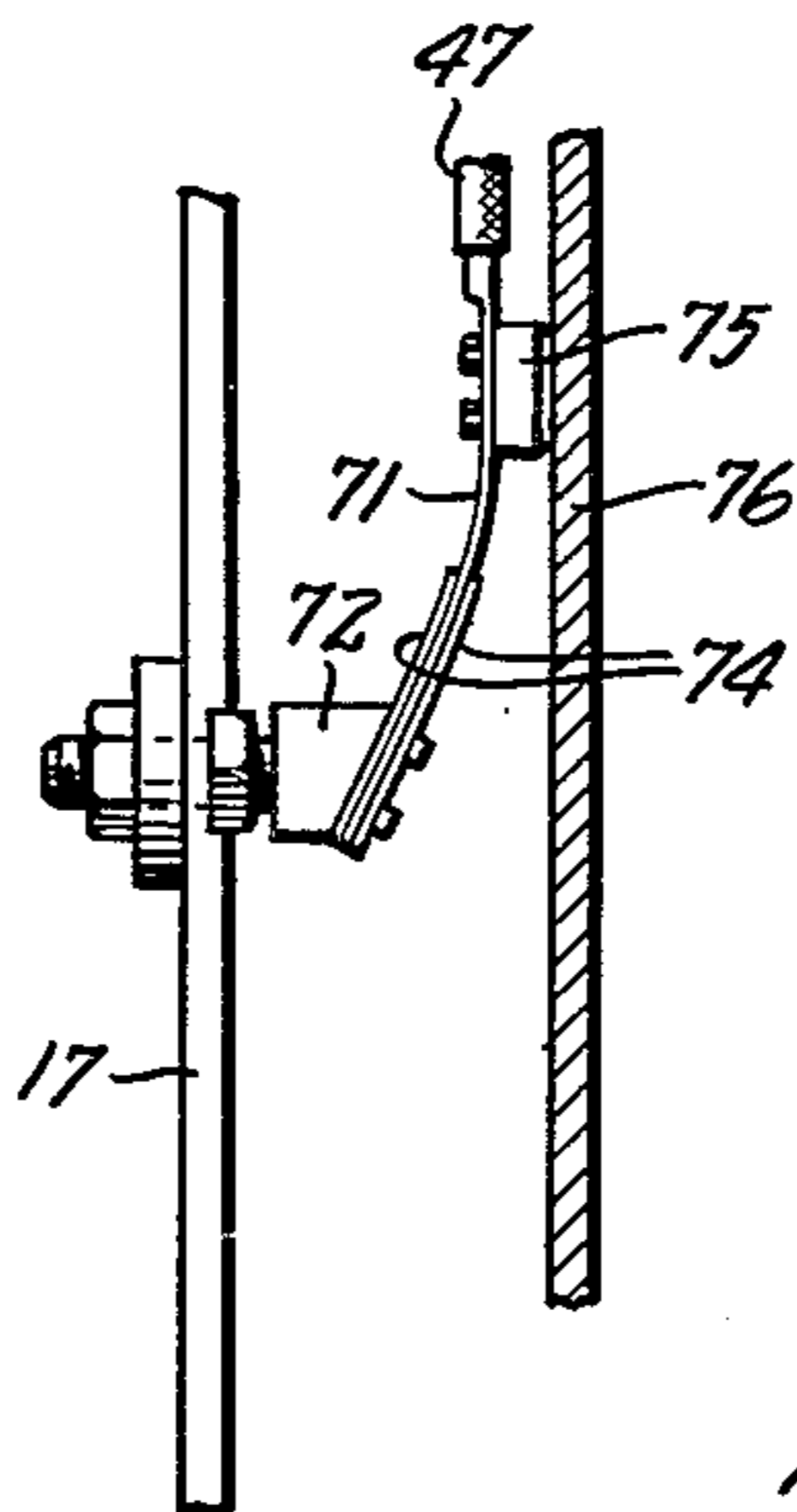

FIG. 7.



INVENTOR
ALDEN W. NELSON

BY *Paulson*
ATTORNEY

1

2,730,987

APPARATUS FOR AUTOMATICALLY VACUUM COATING OF INTERIOR OF GLASS TUBES WITH METAL

Alden W. Nelson, Pawtucket, R. I., assignor to James L. Entwistle Company, Providence, R. I., a copartnership

Application March 25, 1954, Serial No. 418,640

6 Claims. (Cl. 118—49)

This invention relates to new and useful improvements in apparatus for automatically processing the aluminizing of cathode ray tubes such as are employed in television receivers.

According to one of the objects of the invention, carts containing the required pumping and other processing equipment can be readily replaced in the installation and yet convey the tubes with minimum vibration.

This is accomplished by providing heavy carts, i. e. whose weight empty is a substantial part, e. g. one fourth of the total loaded weight, and which roll on wheels near the point where the aluminizing is effected. The object to be treated, i. e. the tube, is on top of the cart, and so are the cart supporting wheels or rollers. The processing equipment (pumps, valves, switches, etc.) constituting about three fourths of the total weight are below the top anchored to the top, bottom and back. Preferably, said wheels, and a third wheel below the center of gravity of the cart, are so mounted that the cart may be put on and taken off the tracks of the installation simply by lifting it vertically.

According to another object of the invention, switches are automatically tripped on the carts during their travel to control first the rough pumping, then the more intensive pumping, and finally the bleeding of the tubes to the atmosphere.

Still other objects of the invention have to do with easily accessible and adjustable electric current connections to the carts, with the adjustability of the cart drive, and with various features whose nature will more clearly appear from the claims and the detailed description applied to the drawings in which:

Fig. 1 is a perspective view of the complete assembly of carts and drive for aluminizing cathode ray tubes;

Fig. 2 is a top plan view of parts of Fig. 1;

Figs. 3 and 4 are two different side elevations of a cart;

Fig. 5 is a section along lines 5—5 of Fig. 3;

Fig. 6 is a transverse cross section of the heater electrode assembly along lines 6—6 of Fig. 4;

Fig. 7 is a cross section along lines 7—7 of Fig. 3 showing the current supply connections to the heater electrodes; and

Fig. 8 illustrates the manner in which the processing control switches are operated as the carts progress.

The aluminizing operation is performed within glass tubes 10 (Fig. 1) while they are carried by carts 11 (the drawings indicate sixteen carts as an example). The carts are heavy and rigid so as to absorb vibration; steel framework 12 (Fig. 3) braced at 13, and 13a and held firmly together by a top 14, back braces 15 and 16, and a bottom 17. The empty cart will weigh about 200 pounds and will, therefore, be heavy and rigid enough to absorb the vibration of motors 18, 19, and pumps 20, 21. The completely assembled cart will weigh about 800 pounds. The pumps are fastened to the bottom plate 17 and the motors to the back plate 15.

2

Motor 18 drives through the agency of belt 23 and pulley 24 the pump 21, and motor 19 drives through a similar belt 25 and pulley 26 pump 20.

The top 14 of each cart supports two arms 27 and 28 inclined at 45° to the horizontal and held together by a brace 29. A roller 30 is mounted on a ball bearing 31 on a stub shaft 32 fastened to the free end of arm 27, and a similar roller 30 is mounted on the free end of arm 28. Each roller has a grooved rim 33 engaging rail 34 mounted on horizontal leg 35a of angle iron 35 (Fig. 3), the rail 34 forming an oval track on which the carts ride as the aluminizing process advances.

Rollers 30 are located as near as possible to the aluminum slug 36 to minimize vibration so that the aluminum, when molten, will remain in place within heating coil 37 and be completely vaporized.

A third roller 38, intermediate to the pair of rollers 30 is mounted on one side of the angle plate 16 below the center of gravity of the cart to engage another oval track 39 mounted on shelf 40 of steel columns like 41 of the machine frame. By means of rollers 30 and 38 each cart 11 will have a three point mounting to rotate around the tracks 34, 39 which are so displaced as to maintain the carts upright. The carts can be placed on and removed from the rails simply by vertically lifting them by a lift truck. One is free to do this on account of the forty-five degree angle tilt of the rollers 30, 38, with respect to the horizontal plane. It will be noted that the rollers 30 are inclined towards the cart and the roller 38 away from the cart, so that their planes of rotation intersect at a right angle insuring firm seating of the cart on the oval tracks 34 and 39 which are located in different horizontal and vertical planes, 34 above, and 39 below the center of gravity of the cart.

The tubes 10 are mounted with their necks 42 projecting through an opening and supported and vacuum sealed by a rubber bushing 43 in the top 14. Two heater electrodes 44 project through neck 42 to a point near the bottom of the bulb portion of tube 10. The lower end of the electrodes 44 project through caps 45 in the bottom of a cylindrical casing 46 which forms a vacuum tight closure around the neck 42 of the tube. The cylinder 46 with rubber bushing 43 is suspended from cart top 14. The lower projecting free ends of the electrodes 44 are connected with conductors 47.

The upper ends of the two electrodes 44 are held in one plane fastened together by an insulating tie 48. Rigidity at an angle of 90° from this plane is insured by two flat springs 49 fastened on either side of the tie 48 and bent out to make contact inside the neck 42 of the tube so as to prevent vibration of heater coil 37 fastened to the upper ends of electrodes 44 by clips 50 and enclosing the aluminizing slug 36.

Pump 20 serves as a gas ballast vacuum pump individually powered by motor 19, quickly to rough down to about 100 microns of mercury the atmosphere within cylinder 46 and, therefore, the tube 10. This is the first pumping stage. While pump 20 operates, a vacuum valve 51 hydraulically operated by a device 52 marketed under the name "Hydro-motor" is automatically opened to the cylindrical chamber 46 when switch 53 is operated. Valve 51 closes when the desired vacuum has been attained in 46 and 10. During the succeeding stage a vacuum valve 54 which, as 51 is operated by Hydromotor 55, will be opened to the oil diffusion pump 22, which in turn is backed up by the vacuum pump 21 via conduit 56. Pump 22 is suspended from top 14 by rods 57 and quickly reduces the remaining atmosphere in the tube 10 from 100 microns to one half a micron or less of mercury, whereupon aluminizing may be effected. This is the second pumping stage.

3

Obviously, valves 51 and 54 may be operated during the travel of the carts by other means than the Hydromotors here disclosed.

The closing and opening of the valves 51 and 54 is controlled by switches 53 and 58 controlled by arms 59, 60, each equipped at its end with a roller 61, 62. The switch control boxes 53, 58 are mounted on the back 16 of the cart. A third box 63, controlling the bleeder valve 64 is mounted between 53 and 58, and has an arm 65 equipped with a roller 66. As shown in Figs. 3 and 8, each roller 61, 62, 66, and thus each arm 59, 60, 65, may be actuated by means of trip buttons, such as 67, 68, located around the oval track in the path of the rollers to push them down and up, and thus to open and close switches 53, 58, 63 at the appropriate time. By changing the position of the trip buttons, which can be readily done by bolts 67A, 68A holding them to uprights 41, any phase of the machine cycle can be easily varied.

A box 69 is mounted on and communicates with chamber 46 and encloses switch 70 which closes only when the cylinder 46 is substantially below atmospheric pressure. Switch 70 controls the circuit of valve 54 whereby the latter cannot open and thus the contamination of the oil diffusion pump 22 will be prevented if the operator fails to place a tube 10 on a cart.

A common source of aluminizing current is used for the carts. Two graphite alloy brushes 71 are mounted on blocks 72 of insulating material carried by the back bracing strip 17 of the cart. Approximately one square inch of the surfaces of brushes 71 is in contact with the terminals 73 of conductors 47 which lead to the heater electrodes 44. The brushes 71 are flexibly mounted and their ends are fastened between spring members 74 to the sloping faces of mounting blocks 72. A carbon brush 75 fastened to the end of brush 71 will be pressed against copper bus bars 76 around the machine frame on insulating strips 77 adjustably mounted on uprights 41. By adjusting the mounting on strips 77 and on blocks 72 by means of bolts 77A, the brush assembly 71, 74 will be bowed firmly to hold the entire flat face of brush 75 against the bus bar 76. It will be noted that the brush 75 will make firm and full contact with the bus bars 76 because its supporting spring 71 is mounted on the cart at 72 which is near the center of gravity of the cart.

The heating current is applied in two stages; a pre-heat of variable short duration to heat the aluminum slug 36 so that it becomes semi-fluid, and a variable final heat of much longer duration to flash and vaporize the semi-fluid aluminum. This vaporized aluminum collects on the inside surface of the tube which is the desired result of the process. The two stages of heat are individually powered by separate voltage indicating powerstats 78 on the primary side of transformers (not shown). For the sake of flexibility, the bus bars 76 are made up of a number of lengths which may be varied depending on the requirements of the final aluminizing heat.

When the carts reach predetermined positions in their travel, arm 60 with roll 62 will cause the closing of the high vacuum valve 54 to the diffusion pump 22 and arm 65 the opening of bleeder valve 64. This is the third and final bleeding step. Valve 64 will bleed the tube 10 back to atmospheric pressure. The bleeder valve 64 is controlled by means of an auxiliary needle valve 81 which may be set slowly to bleed to atmosphere during a desired length of time, whereupon arm 65 will close the valve.

When a cart completes the circuit, its switch arms 59, 60 and 65 will have been returned by appropriately placed pins like 68A (Fig. 8) into normal positions in which the valves 51, 54, and 64 controlling rough and fine pumping and bleeding are closed. The aluminized tube may now be removed from the cart and a new tube put in its place for processing.

A water pump 82 operated by the motor 18 supplies the necessary cooling agent for the oil diffusion pump 22 from a water trough 83, running all around the frame at

4

the feet of uprights 41, via hose 84, pipe 85, pipe 86 coiled around pump 22, and return to the trough via pipes 87, 88.

Power for the individual carts to operate the two pump motors 18 and 19, a diffusion pump heater 90, and to energize the three valve control switches 53, 58, 63, is supplied from a power feed rail system 91 which is located above and to the rear of the carts and is arranged in a continuous oval parallel with the tracks. Power is picked up from the rail 91 by trollies 92 each of which supplies two carts via a plug and receptacle power cord 93. The trollies are pulled around their track by means of a chain 93a (not shown) attached to the leading cart.

The carts are driven about the oval tracks by means of a chain 94 having protruding pins 95 equipped with rollers 96 that engage a slot 97 in a bracket 98 projecting from brace 29 of each cart. The chain 94 is stretched horizontally over two large sprockets 99 which are horizontally mounted at the two ends of the frame, adjustable with respect to one another for insuring that the chain be kept properly taut. One sprocket 99 is driven via a chain 100 from a power shaft 101.

By well-known means, the power input and, therefore, the machine cycle time may be readily varied to insure maximum operator and machine efficiency.

While the device has been described and is particularly adapted in the aluminizing of cathode ray tubes, it will be obvious to those skilled in the art that certain features may be usefully employed for use in other manufacturing processes.

I claim:

1. An automatic vacuum coating apparatus comprising in combination a stationary frame supporting an endless movable conveyor, a plurality of detachably mounted carts spaced on and driven by said conveyor and having means cooperable with said frame for holding each cart upright with its top substantially horizontal, means at the top of each cart for receiving and supporting substantially vacuum-tight the neck of a tube, said tube neck receiver means having means associated therewith comprising a supported heating filament adapted to enter the neck of the tube and adapted to hold a piece of vaporizable metal, the filament being electrically connectable by electrodes to a source of power, means connected to the tube neck receiver means for creating a vacuum, valve means between the receiver and vacuum creating means, switching means mounted on said cart for actuating the valve means, the vacuum creating means and to effect the electrical connection of the heating filament and means projecting into the path of said switches in spaced co-operable relation therewith to effect automatically the sequential operation of the various means via the switches during a vacuum coating cycle.

2. An automatic vacuum coating apparatus comprising in combination a stationary frame supporting an endless movable conveyor, a plurality of detachably mounted carts spaced on and driven by said conveyor and having means cooperable with said frame for holding each cart upright with its top substantially horizontal, an opening at the top of each cart leading into a chamber for receiving and supporting substantially vacuum-tight the neck of a glass tube, said chamber having supported therein and rising above the top of each cart a heating filament adapted to enter the neck of the tube and adapted to hold a piece of vaporizable metal, the filament being electrically connectable by electrodes to a source of power, a roughing vacuum pump and a finishing vacuum pump each connected to the chamber, valve means between the chamber and each of said vacuum pumps, a bleeder valve for bleeding air into the chamber, switching means mounted on said cart for actuating the valve means, for actuating each of said pumps, and to effect the electrical connection of the heating filament, and means projecting from the stationary frame into the path of said switching means in spaced cooperable relation therewith to effect

5

automatically the sequential operation of the various means during a vacuum coating cycle.

3. An automatic vacuum coating apparatus comprising in combination a stationary frame supporting an endless movable conveyor and having two tracks forming closed parallel paths in different horizontal planes vertically displaced one above the other, a plurality of detachably mounted carts spaced on and driven by said conveyor and having roller means cooperable with said tracks for holding each cart upright with its top substantially horizontal, an opening at the top of each cart leading into a chamber for receiving and supporting substantially vacuum-tight the neck of a cathode ray tube having at its other end a face to be coated by a vaporizable metal, said chamber having supported therein and rising above the top of each cart a heating filament adapted to enter the neck of the tube and adapted to hold a piece of vaporizable metal, the filament being electrically connectable by electrodes to a source of power, a roughing vacuum pump and a finishing vacuum pump each connected to the chamber, a first valve between the chamber and the roughing pump, a second valve between the chamber and the finishing pump, a bleeding valve connected to said chamber for restoring it to normal pressure, switching means mounted on said cart for actuating the first and second valves and their associated vacuum pumps, for effecting the electrical connection of the heating filament and for actuating the bleeder valve, and means projecting from the stationary frame into the path of said switching means in spaced cooperable relation therewith to effect automatically the sequential operation of the various means on the cart during a vacuum cycle, whereby the cathode ray tube is roughed down to a vacuum by the roughing pump and next brought down to a high vacuum by the finishing pump, the filament then heated electrically to evaporate the coating metal thereon and finally the bleeder valve actuated to bring the pressure in the tube back to normal to enable its removal from the cart.

4. The vacuum coating apparatus of claim 1 wherein the frame has an endless upper and an endless lower track each lying in a parallel horizontal plane and wherein each cart has two rollers mounted above the top in cooperative relation with the upper track, said rollers rotating in a

6

plane inclined toward the top of the cart at an angle of about 45°, and a roller at the back of the cart below and intermediate the top rollers in cooperable relation with the lower track, said roller rotating in a plane inclined away from the cart at an angle of about 45°, whereby each of said carts is supported upright with its top substantially horizontal.

5. The vacuum coating apparatus of claim 1 characterized in that the electrodes leading from the heating filament are made electrically connectable to a source of power by means of leaf springs of electrically conducting material connected by conductors to the electrodes of said filament, each of said leaf springs having a conducting brush attached thereto adapted to make contact with bus bars located on the frame during movement of the cart about the frame.

6. The vacuum coating apparatus of claim 1 characterized in that a plurality of switches are mounted on the back of each cart, one for controlling each pumping stage and one for controlling the bleeder valve, an arm for each switch having an open and closed position and adapted to cooperate in timed sequence with means projecting from the frame into their paths of travel during a vacuum coating cycle.

References Cited in the file of this patent

UNITED STATES PATENTS

1,492,569	McBride	May 6, 1924
1,812,473	Fay et al.	June 30, 1931
1,816,031	Willis	July 28, 1931
2,101,353	Waalkes	Dec. 7, 1937
2,246,502	Bramsen et al.	June 24, 1941
2,304,859	Strickland et al.	Dec. 15, 1942
2,309,587	Hassler	Jan. 26, 1943
2,569,852	Green	Oct. 2, 1951
2,660,978	Dyne et al.	Dec. 1, 1953

OTHER REFERENCES

Article—"The Automatic Aluminizing Process," page 5, vol. 21, No. 7, September 1954, Sylvania News, pub. by Sylvania Electric Products, Inc., 1100 Main St., Buffalo 9, N. Y.