

Aug. 9, 1955

T. B. SLICK

2,715,013

APPARATUS FOR ERECTING A BUILDING

Filed July 26, 1948

3 Sheets-Sheet 1

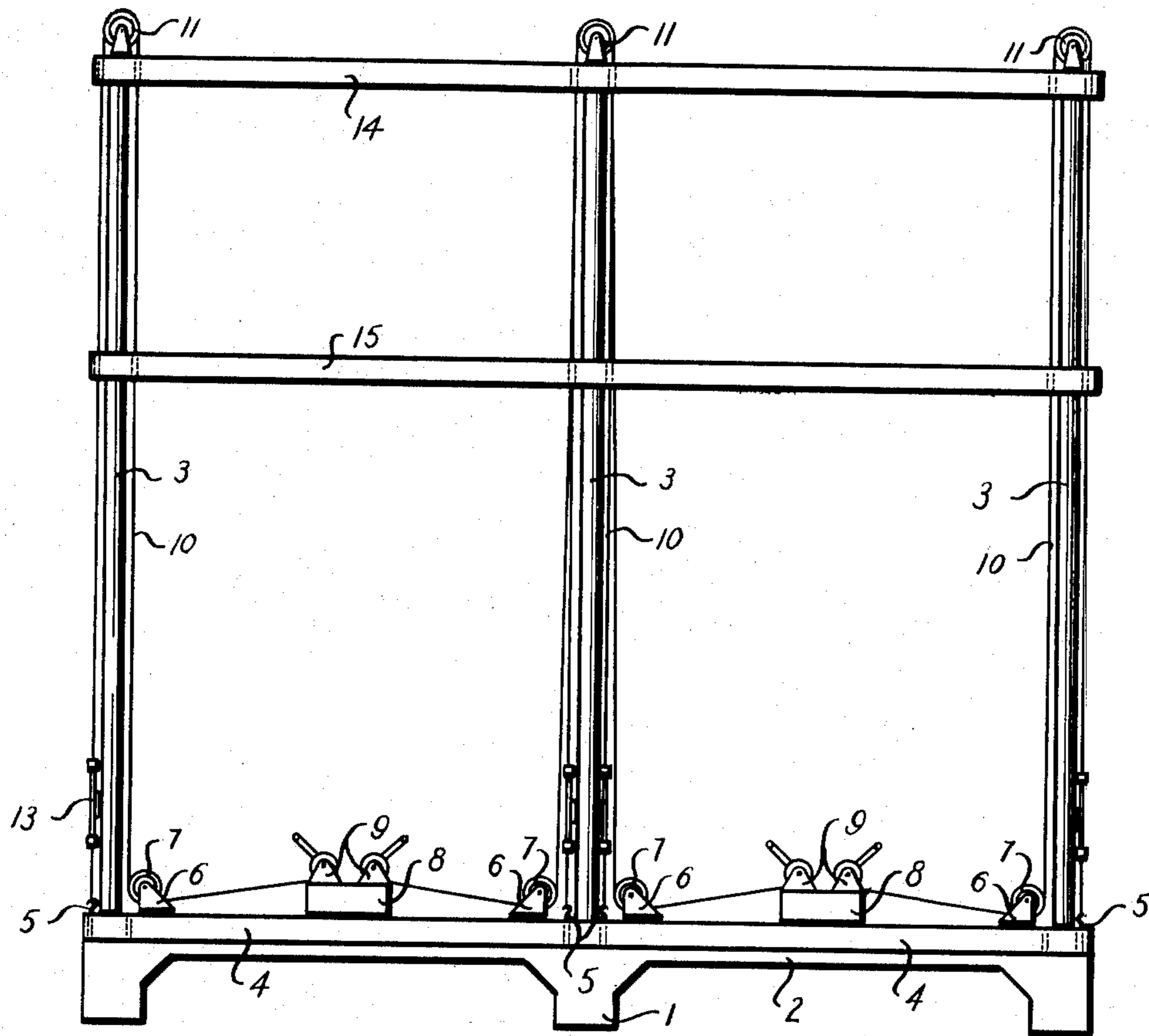
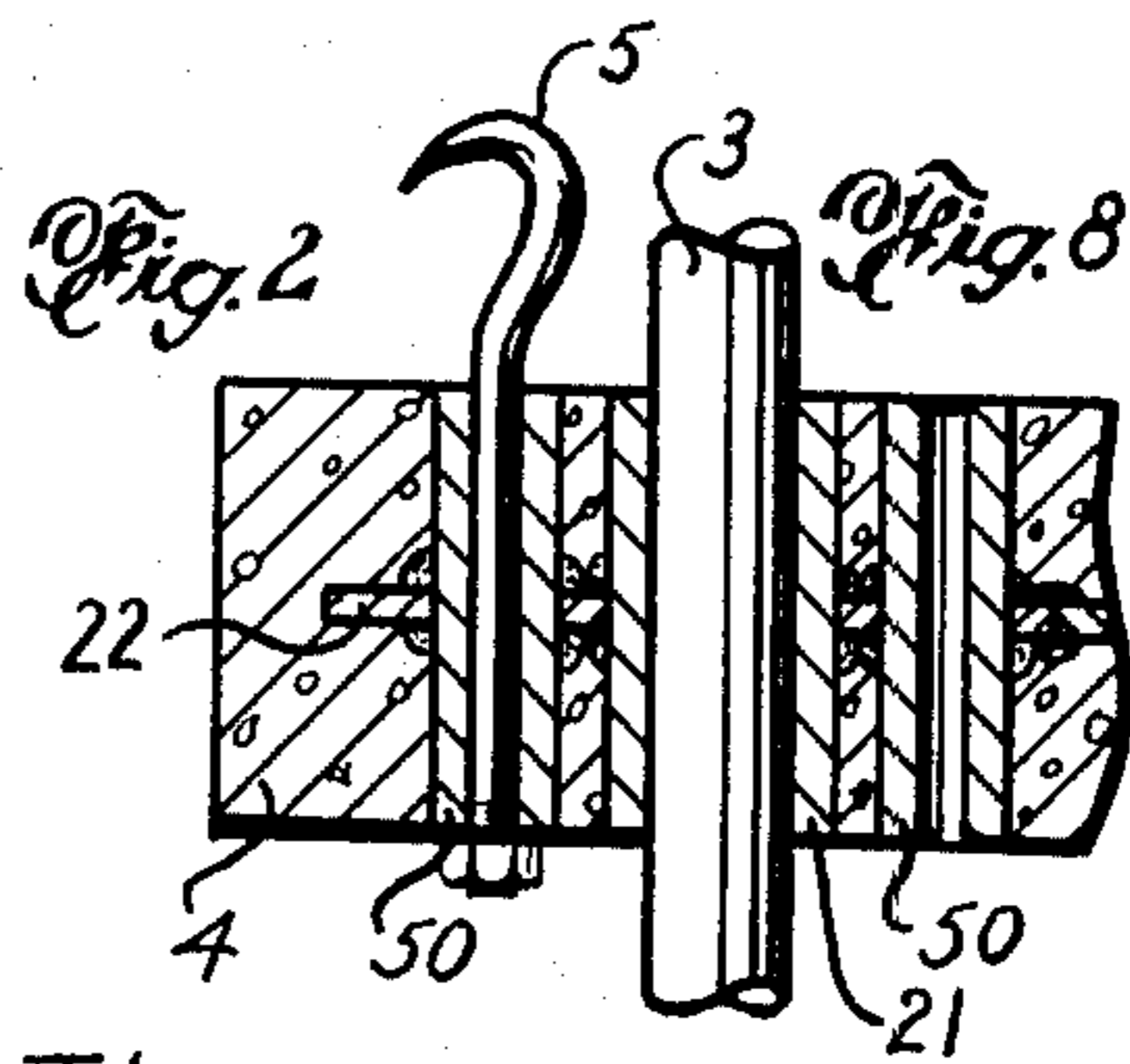
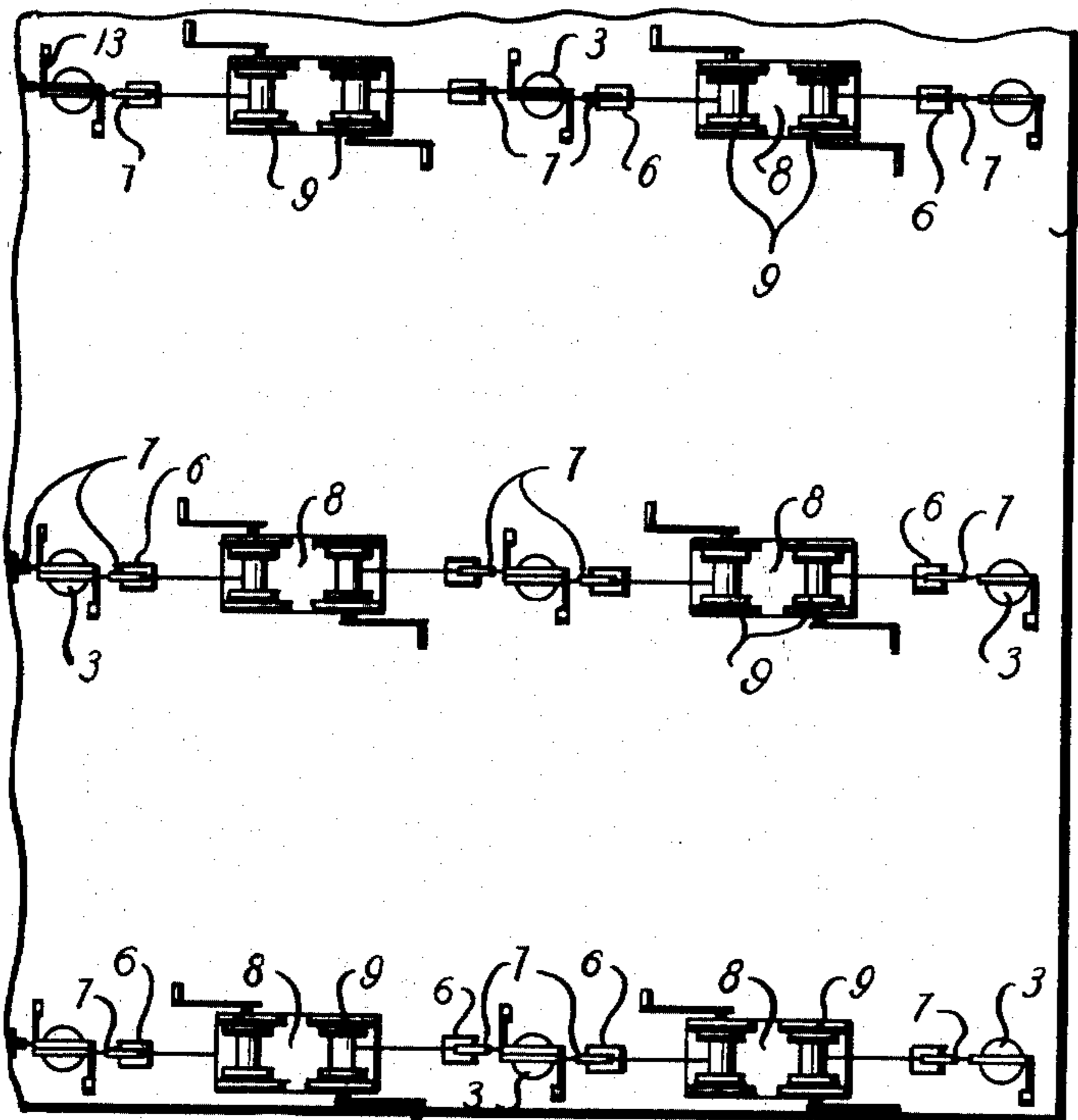

Fig. 1



Thomas B. Slick
INVENTOR.

BY *Browning & Sinner*

ATTORNEYS

Aug. 9, 1955

T. B. SLICK

2,715,013

APPARATUS FOR ERECTING A BUILDING

Filed July 26, 1948

3 Sheets-Sheet 2

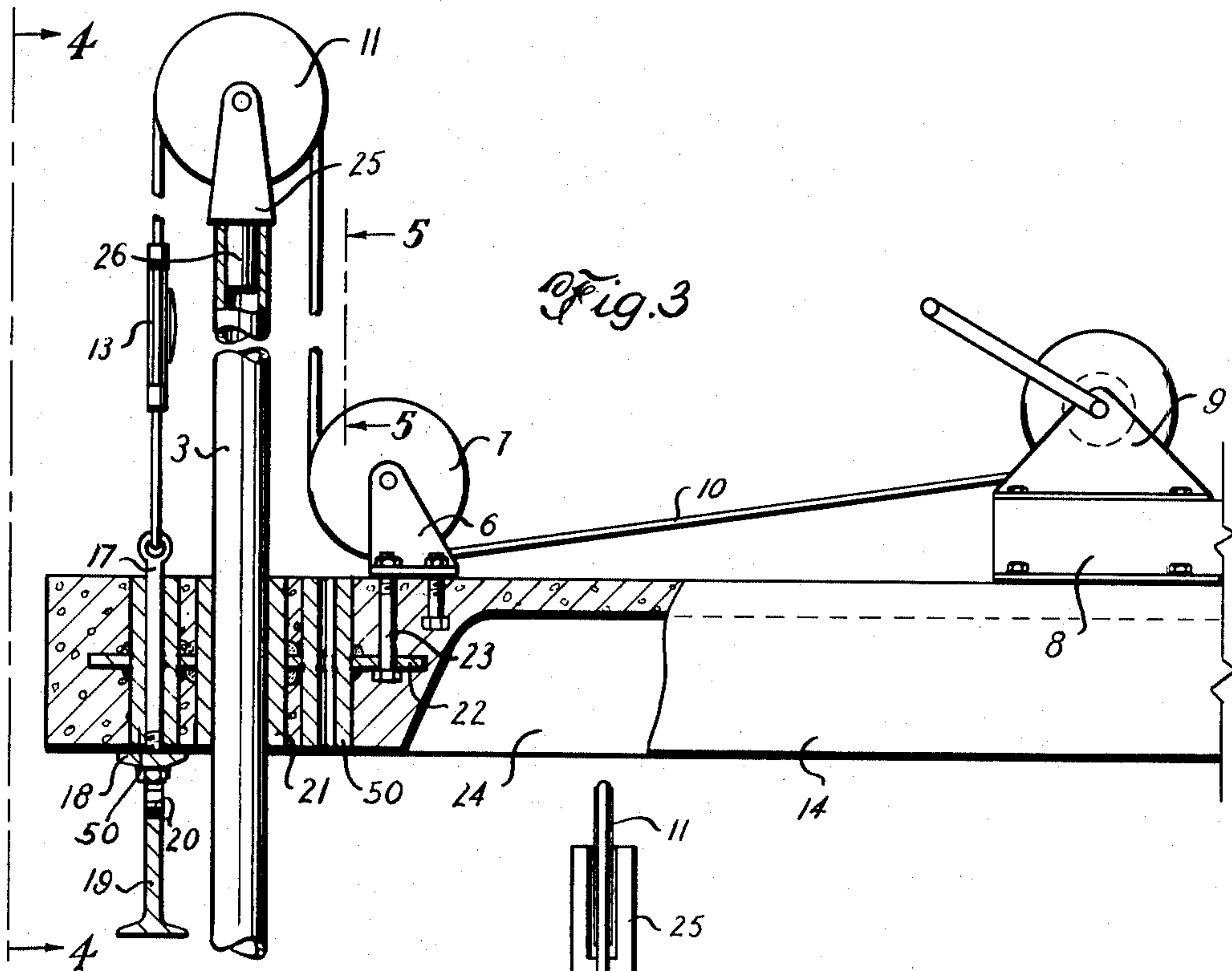

Fig. 3

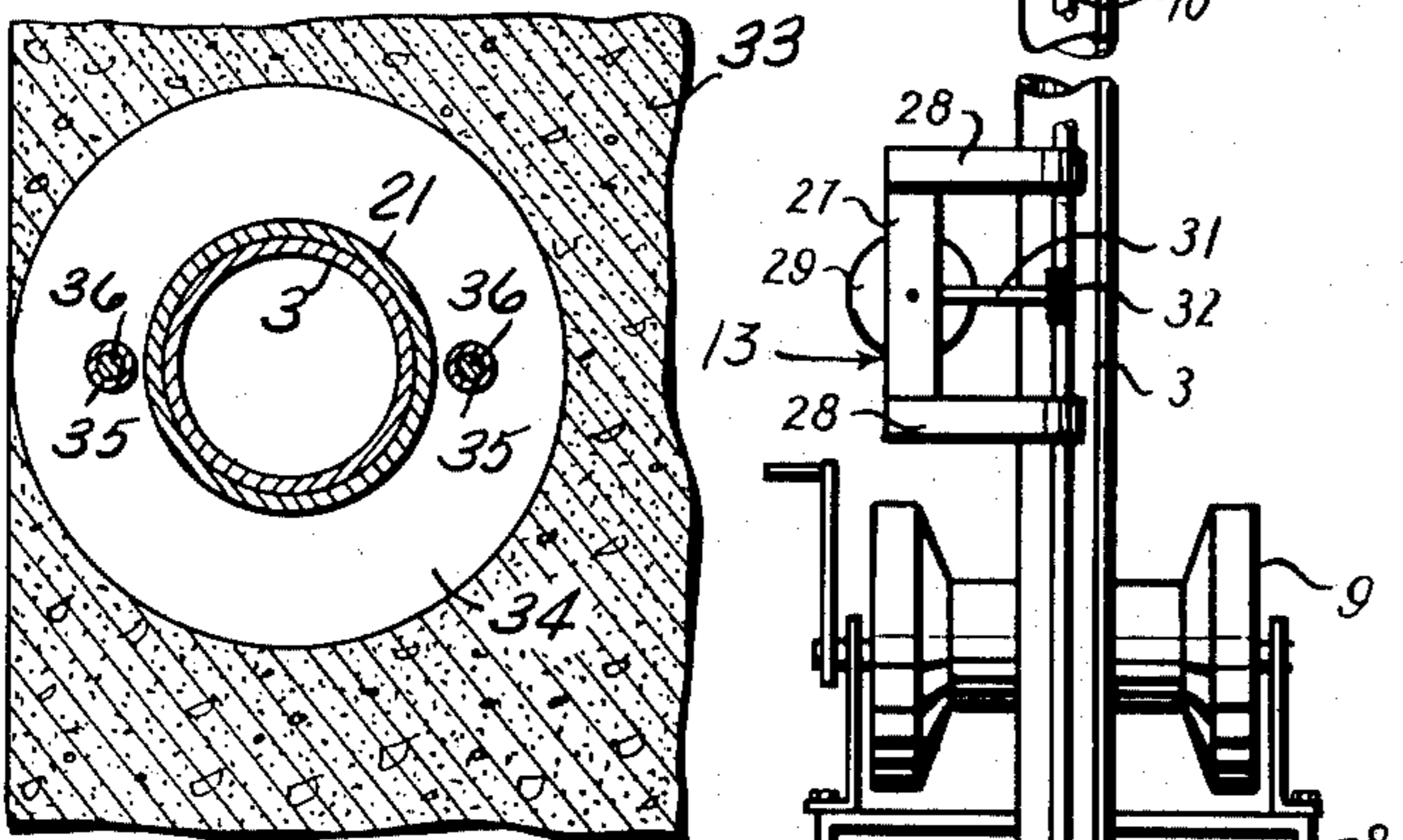

Fig. 4

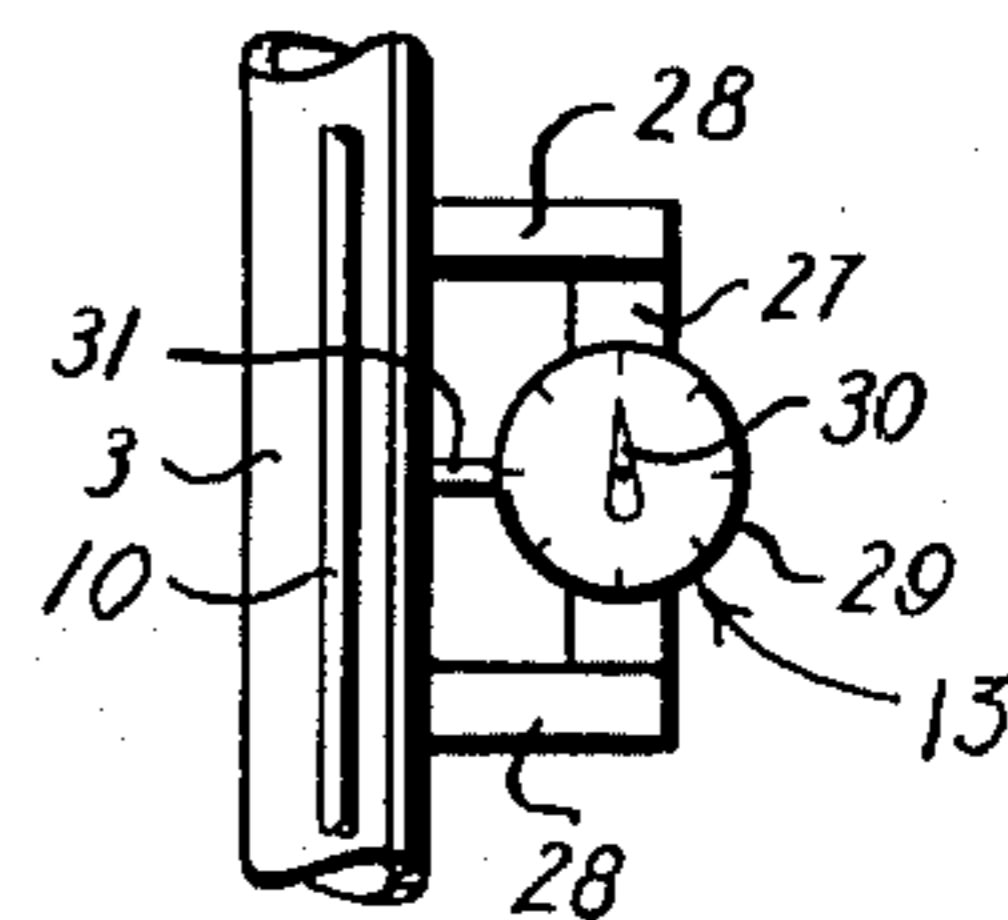

Fig. 5

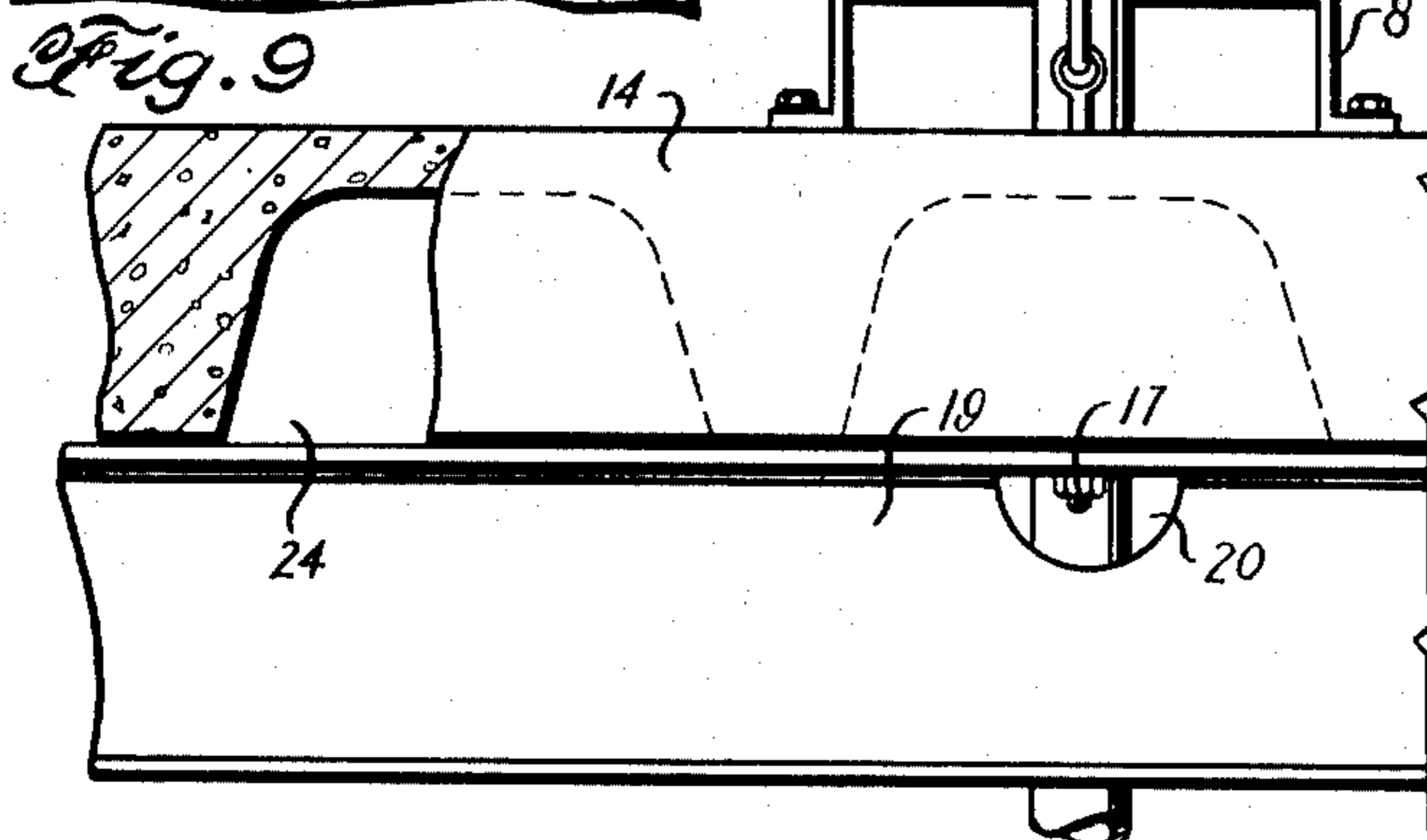

Fig. 9

Thomas B. Slick
INVENTOR.

BY *Browning & Simms*

ATTORNEYS

Aug. 9, 1955

T. B. SLICK

2,715,013

APPARATUS FOR ERECTING A BUILDING

Filed July 26, 1948

3 Sheets-Sheet 3

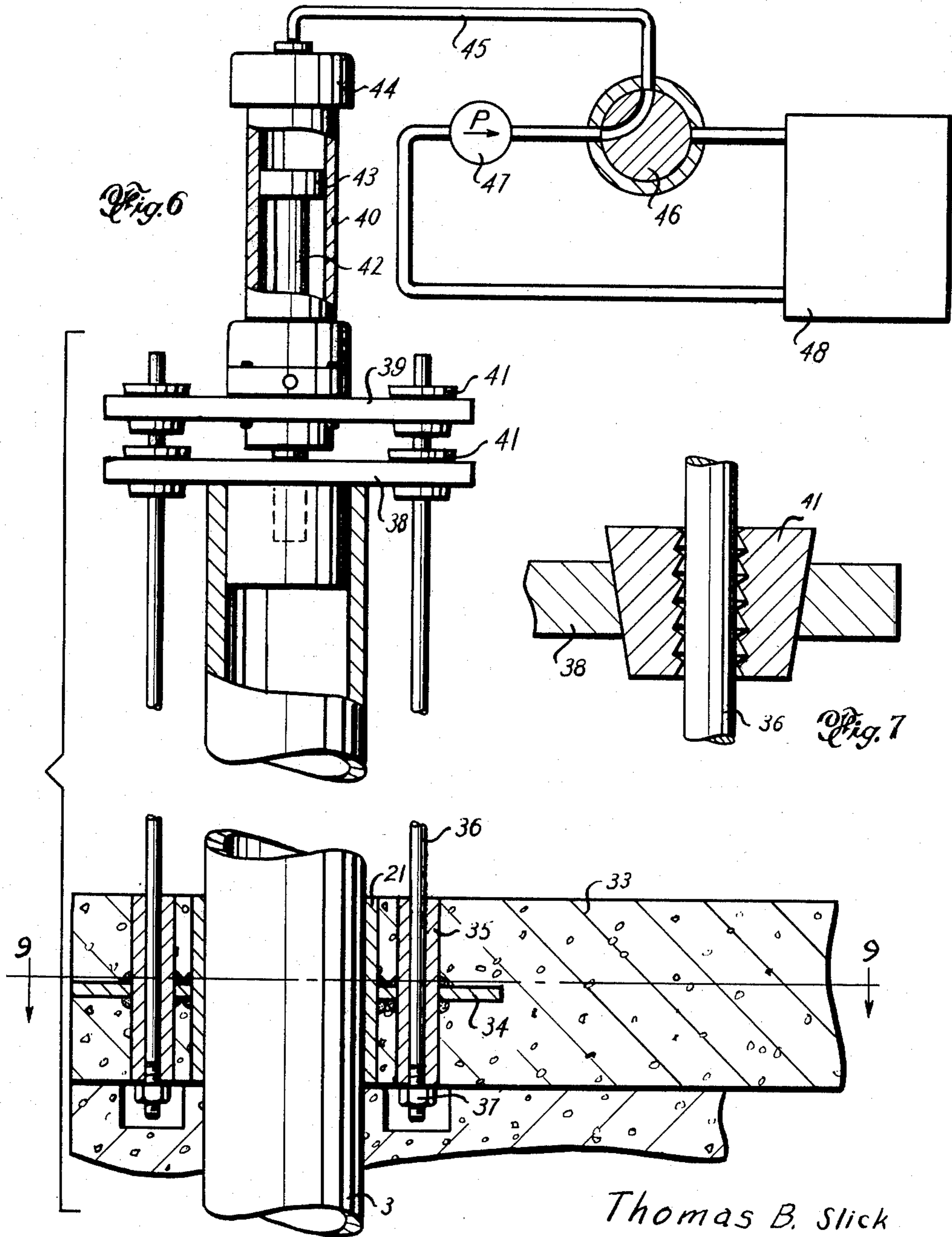

Thomas B. Slick
INVENTOR.

BY *Browning & Simms*

ATTORNEYS

1

2,715,013

APPARATUS FOR ERECTING A BUILDING

Thomas B. Slick, San Antonio, Tex., assignor, by mesne assignments, to United States Lift Slab Corporation, Austin, Tex., a corporation of Delaware

Application July 26, 1948, Serial No. 40,746

1 Claim. (Cl. 254—106)

This invention relates to the construction of buildings and has for its general object an improvement in the method of and apparatus for the economical construction of buildings, and an improvement in building structure.

This invention relates particularly to the construction of buildings of concrete or other moldable or formable material, although certain phases of the invention are likewise applicable to buildings constructed of wood, steel or the like.

A specific object of this invention is to avoid the practice in conventional building methods which involves the necessity for hoisting into position the parts or elements of the floor and roof structures of a building and the fabrication of such floor and roof structures at the upper levels which they are to occupy in the finished building.

Another object of this invention is to provide a method of building construction which will make it possible to carry out at approximately ground level the maximum amount of the work of fabrication of the floor and roof structures.

More specifically it is the object of this invention to make it possible to construct at approximately ground level the floor and roof structures of a building in which such structures are of monolithic concrete.

Another object of this invention is to provide a means whereby a substantially complete floor or roof structure may be readily elevated from a point of fabrication adjacent the ground level to a higher point which it is to occupy in the finished building.

Another object of this invention is the elimination of all concrete forms and shoring, both above ground and on the ground level with the exception of foundation forms and side forms for slabs which are poured on the foundation, ground, or ground floor.

Another object is to provide a building construction in which the necessity for extensive scaffolding or temporary supporting members will be avoided, and in which the support for the parts of the floor and roof structures during the fabrication will be solid and true, thus facilitating the accurate and economical fabrication of such floor and roof structures.

Another object is to provide a method of building construction in which the dangers attendant upon working at elevated levels will be reduced to a minimum.

Other objects and advantages of this invention will become apparent from the following description taken in connection with the accompanying drawings wherein are set forth certain embodiments of the invention.

In the drawings:

Fig. 1 is a side elevation of a partly completed building constructed in accordance with this invention.

Fig. 2 is a top plan view of a building such as illustrated in Fig. 1 but showing the same just prior to the elevation of the roof slab.

Fig. 3 is a view on an enlarged scale, partly in cross section and partly in elevation illustrating the details of

2

mounting and arrangement of one of the units of the hoisting apparatus shown in Fig. 1 and Fig. 2.

Fig. 4 is a view partly in elevation and partly in vertical cross section taken substantially along the line 4—4 of Fig. 3.

Fig. 5 is a fragmentary view taken along the line 5—5 of Fig. 3 and illustrating in elevation the tensiometer employed in connection with each of the elements of the hoisting apparatus shown in Figs. 1 to 4 inclusive.

Fig. 6 is a view similar to Fig. 3 illustrating a modified form of apparatus for hoisting a completed unit of the building structure into place.

Fig. 7 is a vertical cross-sectional view on an enlarged scale illustrating a portion of the apparatus shown in Fig. 6.

Fig. 8 is a vertical cross-sectional view on an enlarged scale showing the bearing, the guide, and the anchoring structure generally illustrated in Fig. 1 and Fig. 2.

Fig. 9 is a horizontal cross-sectional view taken on the line 9—9 of Fig. 6.

Referring now more in detail to the drawings, the numeral 1 in Fig. 1 designates a foundation structure which in its details forms no part of the present invention and which may be of any conventional form suitable for the weight and the nature of the building to be constructed. In the instance illustrated, it may be assumed that the foundation 1 is of concrete and that there is formed on the foundation a conventional concrete floor slab 2 which, if desired, may be integral with the foundation. In the construction of the foundation and of the conventional floor slab 2 there may be anchored a plurality of upright supports or columns 3 adapted to support the upper floors and roof of the building. These columns may be anchored in the body of the foundation by being placed before the foundation is poured or in any other conventional or desirable manner. In most instances they would be vertically arranged and in all cases must be parallel to each other. They may be of any well-known construction or design sufficient to support the load which they are intended to carry. In the illustration they are cylindrical and may be preferably of steel or other suitable metal, or of reinforced concrete with steel sleeves at the level where the floor and roof slabs are to be located.

In Fig. 1 there is shown resting directly upon the upper surface of the floor slab 2 a slab 4 which is adapted to form one of the upper floors of the building. This slab 4 is, in accordance with this invention, formed directly upon the floor slab 2 and is supported during the forming process by the floor slab 2 throughout the extent of the slab 4. It is readily apparent that, if desired, the lower slab 2 may be eliminated and the slab 4 formed on the ground or on suitable supports adjacent the ground, and then elevated and anchored at a position where it will constitute the lowermost floor.

In the construction of the slab 4, as illustrated, there is placed around the outside of the slab 2 a form (not shown) of any conventional design. The upper surface of the slab 2 is provided with a suitable parting material such as paraffin, paper, rubber sheets or similar material. Suitable bearing guide members 21 substantially surrounding each of the columns 3 and freely slidable thereon are placed around the respective columns. Tubular anchors 50 are also positioned adjacent the bearing members 21 for the purpose hereinafter stated. These members and anchors are of such a length as to extend through the slab to be poured and the members may be initially split to make it possible to place them around the columns.

Suitable reinforcements for the new slab, and also bolts for the pulley blocks 6 which carry the sheaves 7 are put in place so as to be anchored firmly in the new slab when it is poured. The hooks 5 will preferably be adapted to be anchored in anchors 50 as shown in Fig. 8. Fur-

3

thermore, suitable bolts are placed for anchoring the bases 8 upon which the winches 9 are later to be mounted.

The slab 4 is then poured directly on the floor slab 2 and allowed to set.

When the slab 4 has completely set so that it has sufficient inherent strength to enable it to be hoisted into position, suitable cables 10 are anchored to the hooks 5 and passed upwardly over sheaves 11 at the upper ends of the respective columns 3. These cables are then passed downwardly along the opposite sides of the respective columns 3 and through the sheaves 7 after which they are connected to the winches 9. Each cable has attached to it adjacent the hook 5 a tensiometer 13, the details of which will be presently set forth.

It will now be seen that by manipulation of the winches 9 the entire slab may be raised, sliding up along the column 3, until it is in the final position desired. During this raising operation substantially equal tension may be exerted upon the cables 10 by merely observing the respective tensiometers 13 and operating the winches in such a manner as to keep all tensiometers at substantially such readings as would place the least amount of bending stress upon the slab. When the slab 4 has been raised to the desired position, it may be anchored in any manner deemed desirable, and in cases in which the columns and bearing members within the slab are both of steel or the like, these bearing members may be welded directly to the columns in order to permanently position the slab at the elevation desired. After the slab has been so positioned and welded or otherwise secured, the winches, cables, sheaves, etc., mounted thereon may be removed for later use as desired.

In the showing to be found in Fig. 1, a roof slab 14 and a third-floor slab 15 are illustrated as already in place, but it will be understood that these slabs, within the contemplation of this invention will have been formed on the ground floor slab 2 and later elevated to position, in the same manner as has been described in connection with the slab 4. It will be apparent that in the structure illustrated in Fig. 1, the first slab to have been poured on top of the slab 2 will have been the roof slab 14 and that after the elevation of this roof slab to the position illustrated in Fig. 1, the pouring and elevation of the slab 15 will have been accomplished. Because the structure therein set forth is the same as that illustrated in Fig. 1 with the exception that the view shown in Fig. 2 is taken looking down upon the roof slab at the time that it is ready to be hoisted into its final position, no further description of Fig. 2 will be necessary.

In Fig. 3 the structure is illustrated more in detail and in this figure it will be seen that there is a slightly modified form of anchor employed. Instead of the hook 5 there is illustrated an eye-bolt 17 which extends through the anchor 50 in the slab 14 and is anchored at its lower end to the upper flange 18 of an I-beam 19 which extends along the underside of the slab 14. The I-beam 19 has its web provided with a hand hole 20 which affords access to the nut on the lower end of the bolt 17.

Extending through the slab 14 and surrounding the column 3 in slidable relation thereto is a tubular bearing guide member 21 which is preferably of metal or the like, and which, as hereinbefore stated, is put in place around the column 3 before the pouring of the slab 14. Also embedded in the slab 14, and surrounding and preferably secured to the bearing member 21 and the anchor 50 as by welding or the like, is a plate 22 forming a flange to properly space and assist in anchoring the anchor 50 and the bearing member 21. Thus there is formed a combined anchor and bearing guide which is slidably mounted on its respective upright support or column 3. Hollowed-out portions 24 may be formed in the under surfaces of roof and floor slabs constructed in accordance with this invention in the same manner that such hollowed-out portions are formed in similar slabs in conventional concrete structures.

4

The sheaves 11 are mounted on the upper ends of the respective columns 3 by means of pulley blocks 25 having portions 26 which extend into the hollow upper ends of the column 3. It will be understood, however, that any suitable means of mounting these sheaves 11 may be employed.

As illustrated in Figs. 4 and 5, the tensiometer 13 is mounted directly upon that portion of the cable 10 which is anchored to the slab. The mounting for this instrument includes a rigid bar 27 which is substantially parallel to and spaced from the cable 10, and a pair of bars 28 at substantially right angles to the bar 27, the bars 28 being secured to the opposite ends of the bar 27 and having parts embracing the cable 10.

The body 29 of the tensiometer has a dial properly graduated, together with an indicating hand or pointer 30 which swings over the graduation on the dial. This hand is connected to a fourth bar 31 located between the two bars 28 and having a part 32 bearing against a portion of the cable 10 between the bars 28. The lengths and adjustments of the bars 28 and 31 are such that when there is no tension or only slight tension on the cable, the bar 31 will deflect laterally that portion of the cable against which it bears. When additional tension is placed on the cable, this deflection will tend to be taken out of the cable with a consequent movement of the bar 31 and a turning of the pointer 30 which will serve to indicate the amount of increased tension on the cable. These tensiometers are so positioned that each will be in plain view of a person operating the winch which is connected to the cable on which the tensiometer is mounted.

Referring now to the modified form illustrated in Figs. 6 and 7, it will be noted that this form embodies a means for elevating the slab by means of hydraulic pressure instead of by a cable hoist such as just described.

In connection with Figs. 6 and 7 it will be noted that the slab 33 is provided with a tubular bearing member 21 extending therethrough in substantially the same manner as hereinbefore described. Also, there is provided an anchor plate or flange 34 similar in function and disposition to the flange 22. However, instead of the hook 5 or the eye-bolt 17 and the pulley block 6 the slab is provided with a pair of tubular anchors 35 extending therethrough substantially parallel to and on opposite sides of each column 3. Extending through these anchors 35 are bolts or rods 36 having nuts 37 on their lower ends. The upper ends of these bolts or rods extend through openings in cross heads 38 and 39 which are mounted respectively on the upper end of the column 3 and on cylinder 40 movable upwardly and downwardly with respect to the column 3 in a manner presently to be described.

As appears more in detail in Fig. 7, each of the cross heads 38 and 39 is provided with tapered toothed wedges or slips 41 which will move upwardly and apart to permit the bolts or rods 36 to move upwardly through the cross heads, but upon downward movement with respect to the cross heads, will move toward each other and grip these rods to prevent them from moving downwardly through the cross heads.

A piston rod 42 is carried on the upper end of the column 3 and extends upwardly into the cylinder 40. Located on the upper end of this piston rod is a piston 43 which effects a fluid-tight sliding seal within the cylinder 40. The upper end of the cylinder 40 is closed by a cylinder head 44 through which is connected a conduit 45 by which pressure fluid may be injected into the cylinder 40 above the piston 43.

This conduit 45 is connected to a 2-way valve 46 which is positionable to connect the conduit 45 to a pump 47 or to a reservoir 48 according to the desires of the operator.

It will be seen that when the valve 46 is in the

5

position shown in Fig. 6, pressure fluid will be drawn by the pump 47 from the reservoir 48 and forced into the upper end of the cylinder 40. This fluid will act between the cylinder head 44 and the upper end of the piston 43 to force the cylinder and its associated cross head 39 to move upwardly with respect to the column 3. In the course of this movement, slips 41 on cross head 39 will grip the rods 36 thereby causing the rods, and the slab 33 to which they are secured to move upwardly with respect to the column 3. Slips 41 on cross head 38 will allow the rods 36 to slip freely in an upward direction but will restrain rods 36 from downward movement.

When the upper limit of movement of the cylinder 40 has been reached, the valve 46 will be turned to permit pressure fluid from the upper end of the cylinder 40 to flow back into the reservoir 48. The weight of the cylinder 40 and the cross head 39 will during this time cause these parts to move downwardly to their original position. In the course of this movement the slips 41 within the cross head 39 will loosen to permit the cross head to move downwardly with respect to the rods 36, but the slips 41 within the cross head 38 will grip these rods and prevent downward movement of the rods and the slab 33 thus, by successive steps, the slab 33 may be raised to any amount desired.

It will be appreciated that by connecting all of the cylinders acting upon a single slab to a single source of pressure, balance lifting upon the slab may be obtained at desired points, and excessive stresses and strains in the slab will be avoided.

It will be appreciated that a method and means has been set forth by which all of the objects and advantages of this invention will be obtained. It will further be appreciated that while the specific means and method set forth represent preferred embodiments of the invention, the same may be varied within the scope of the appended claim without departing from the spirit or scope of this invention.

Having described my invention, I claim:

Apparatus for erecting a building including a hoisting unit, said unit comprising an elongated force transmitting member; a jack having parts relatively movable toward and away from each other alternately during operation and having tapered sockets therein; downwardly tapered segmented slips carried by each of said relatively movable jack parts in the correspondingly tapered sockets in the jack parts, said member extending through one of said sockets in each jack part and being spaced from the walls thereof with said slips positioned therebetween whereby, when the jack is operated in one direction, one of the parts will move upwardly with the respective slips thereof forming a fixed connection with

6

said force transmitting member to lift the member upwardly relative to the other of said jack parts as the member slides freely through the respective slips of said other part, and whereby, when the jack is operated in the opposite direction, said one jack part will move downwardly accompanied by initial downward movement of the member relative to said other jack part, the respective slips of said other part seating in the socket thereof to form a fixed connection with said member to hold it stationary, and simultaneously therewith the slips of the one jack part becoming free from their fixed connection with said member in said stationary position and sliding and following the one part as it moves downwardly; an upright support, said other jack part being supported on the upper end of said upright support, a combined anchor and bearing guide slidably mounted on said upright support below said jack, said force transmitting member being liftingly secured to said combined anchor and bearing guide, whereby a slab cast about said combined anchor and bearing guide may be raised by said jack to a desired elevated position for permanent attachment to said upright support.

References Cited in the file of this patent

UNITED STATES PATENTS

103,899	Lewis	June 7, 1870
216,326	Hyde	June 10, 1879
762,808	Cushing et al.	June 14, 1904
1,066,436	Peltzer	July 1, 1913
1,101,983	Barbour	June 30, 1914
1,163,210	Bush	Dec. 7, 1915
1,225,866	Schrears	May 15, 1917
1,398,209	Van Bavegem	Nov. 22, 1921
1,465,166	Matthews	Aug. 14, 1923
1,726,286	Bennet	Aug. 27, 1929
1,784,154	Mitchell	Dec. 9, 1930
1,859,814	Wyckoff	May 24, 1932
1,901,962	Greene	Mar. 21, 1933
1,912,149	Latimer	May 30, 1933
1,924,317	How et al.	Aug. 29, 1933
1,958,026	Walker	May 8, 1934
2,016,575	Nemec et al.	Oct. 8, 1935
2,099,662	Slonneger	Nov. 16, 1937
2,335,227	Baron	Nov. 30, 1943
2,339,152	Connelly et al.	Jan. 11, 1944
2,471,301	Boosey	May 24, 1949
2,482,027	Poole	Sept. 13, 1949
2,540,679	Laffaille	Feb. 6, 1951

FOREIGN PATENTS

684,089	France	1930
854,140	France	1940