

May 24, 1955

J. G. NIGRO

2,708,835

MOBILE AND PORTABLE AIR CONDITIONER

Filed Jan. 18, 1954

2 Sheets-Sheet 1

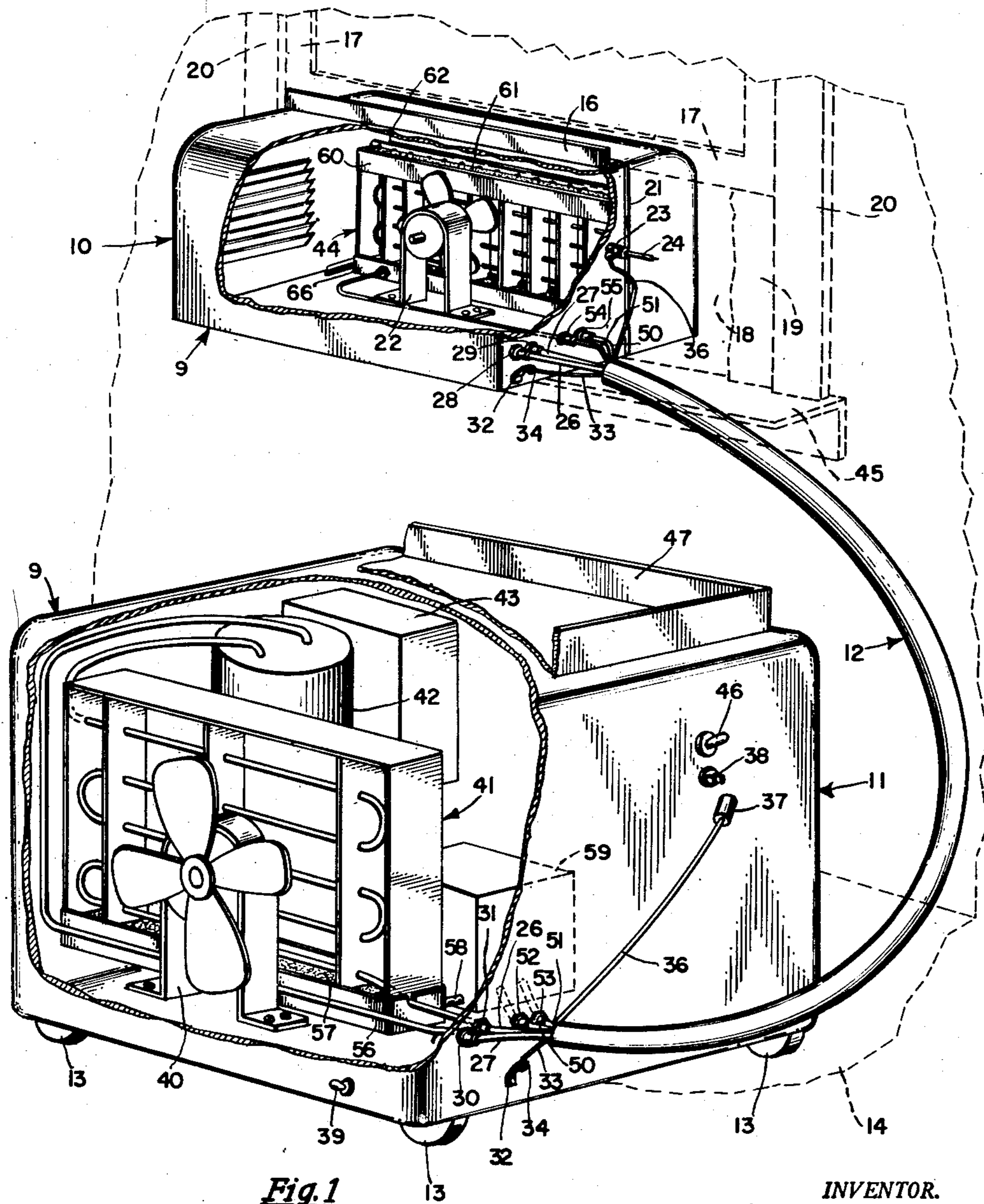

Fig. 1

INVENTOR.
JOSEPH G. NIGRO

BY

David Wray Selby

ATTORNEY

May 24, 1955

J. G. NIGRO

2,708,835

MOBILE AND PORTABLE AIR CONDITIONER

Filed Jan. 18, 1954

2 Sheets-Sheet 2

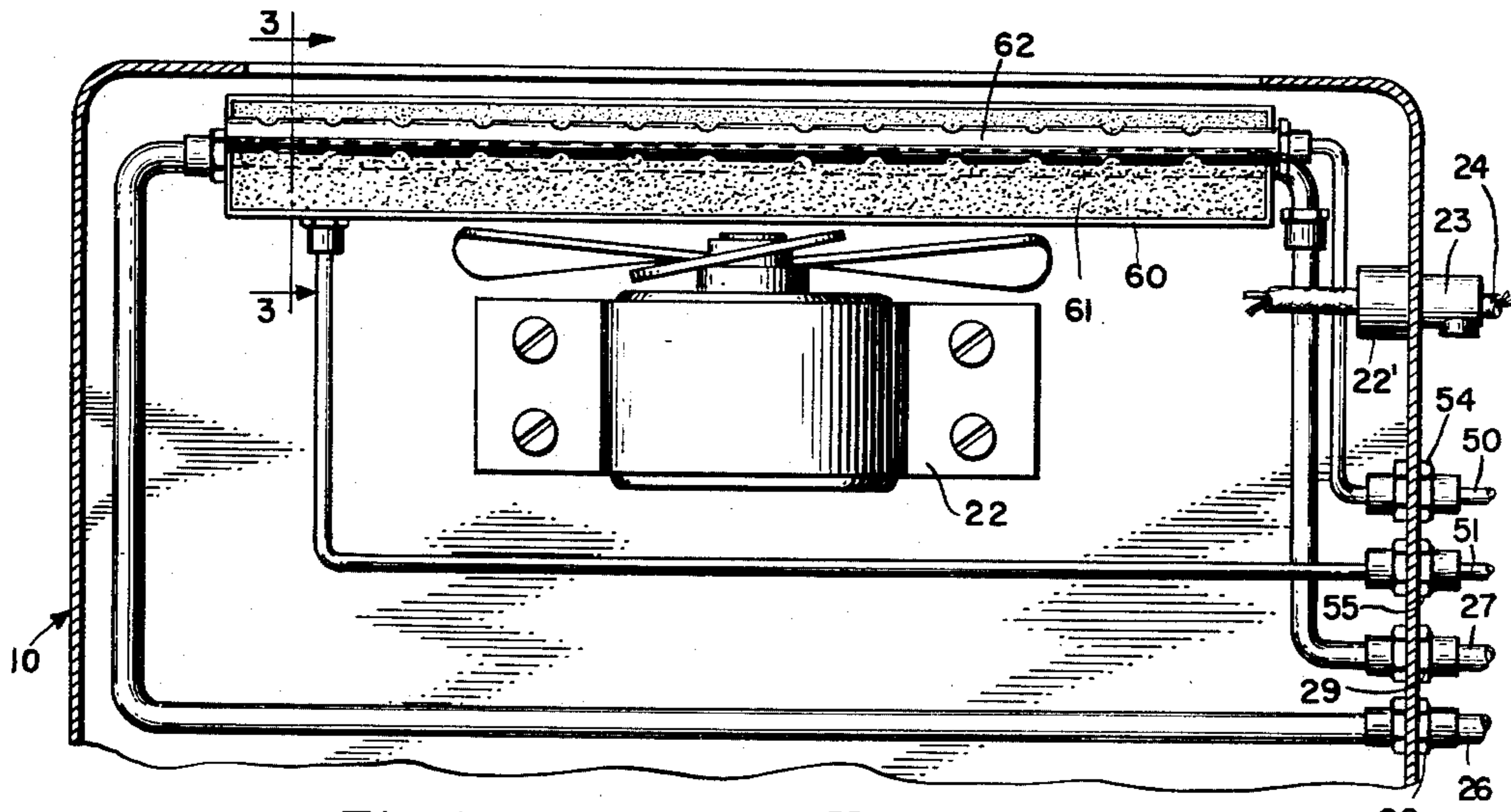

Fig. 2

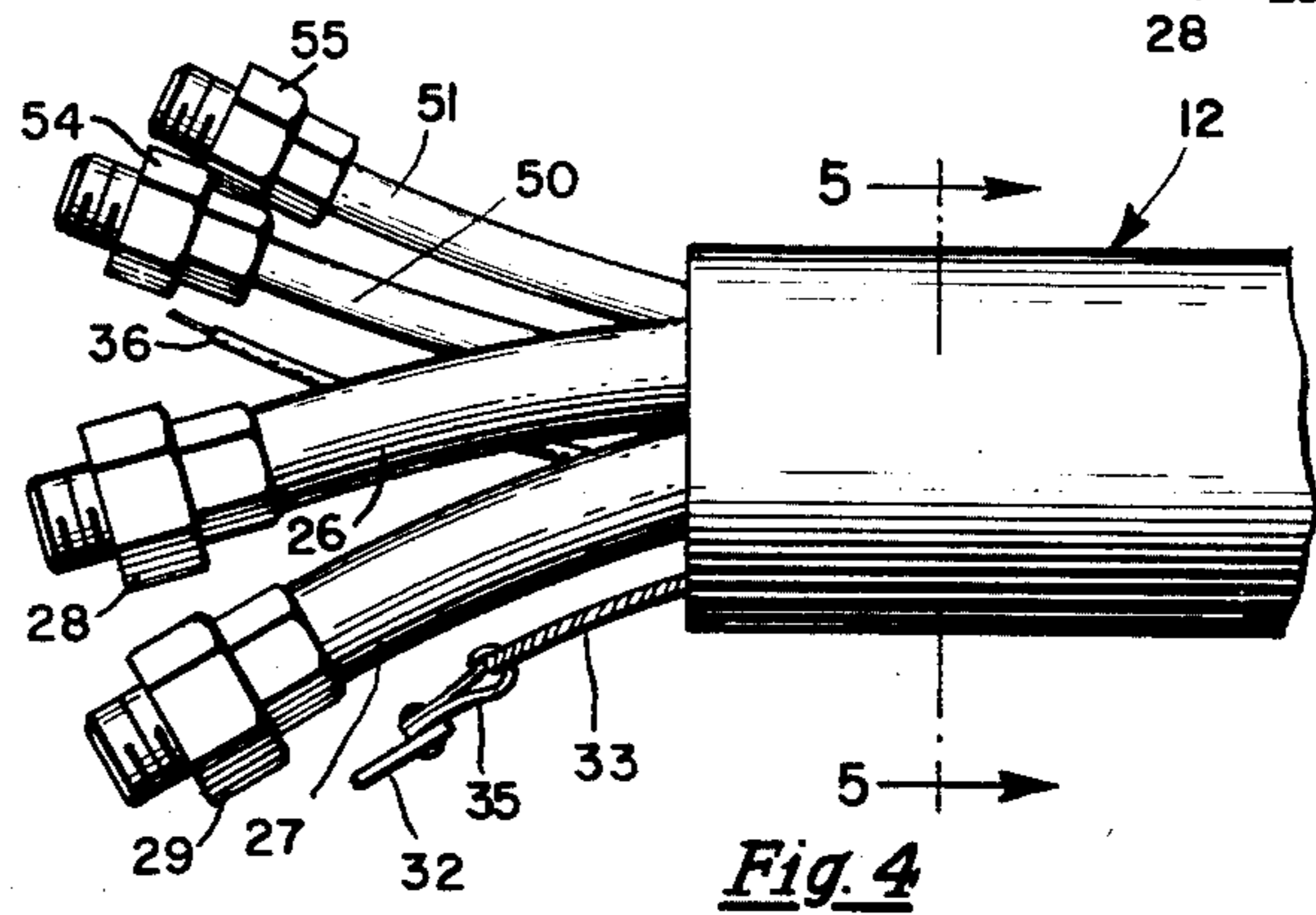

Fig. 4

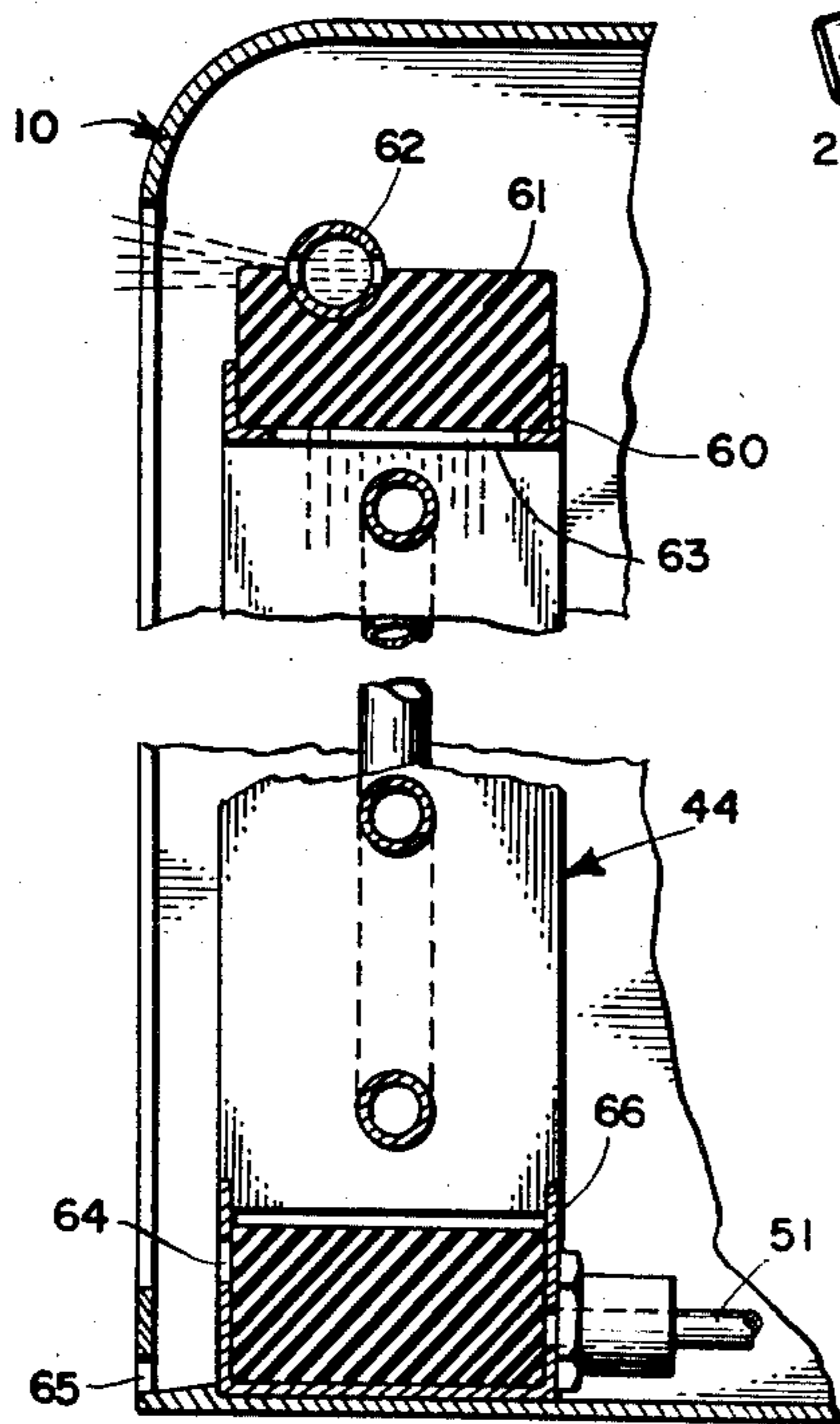

Fig. 3

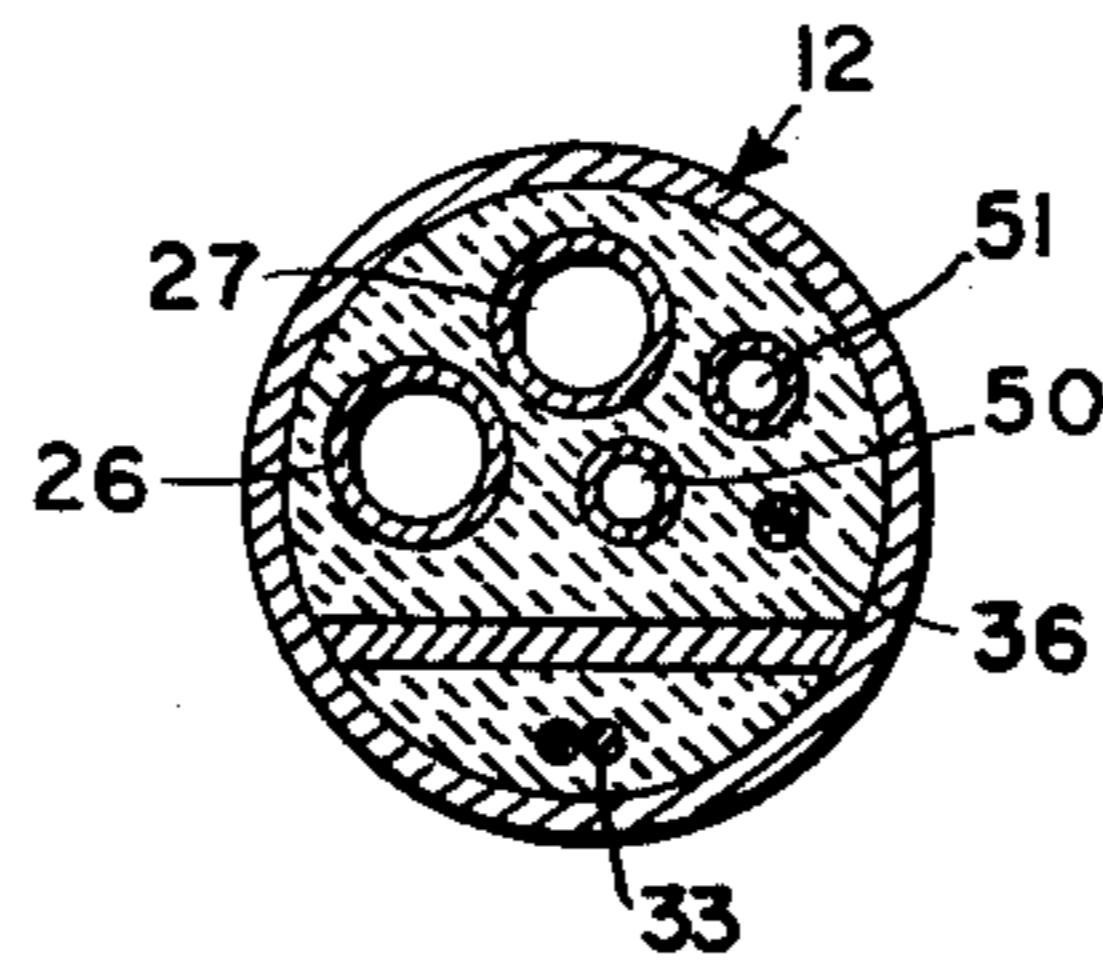

Fig. 5

INVENTOR.
JOSEPH G. NIGRO

BY *David M. Seller*
ATTORNEY

1

2,708,835

MOBILE AND PORTABLE AIR CONDITIONER

Joseph G. Nigro, Chicago, Ill.

Application January 18, 1954, Serial No. 404,461

5 Claims. (Cl. 62-140)

2

My invention relates to mobile air conditioning means and constitutes a continuation-in-part of my copending application, Serial No. 339,230, filed February 27, 1953.

A general object of my invention is to provide air conditioning means of the aforementioned character, which consists of two units, namely, a mobile compressor unit, and a portable condensing unit, as component units interconnected by flexible cable means, so that the same may be moved from room to room or from one part of a room to another, near windows, so that the same may be installed in a window as indicated in Fig. 1.

A still further object of my invention is to provide, in air conditioning means of the aforementioned character, condensate circulating means operating in concert with absorbent means to circulate and, if necessary, to recirculate the condensate resulting from the operation of the device.

The line of division between the present application and my earlier and copending application, Serial No. 339,230, is based upon the following principles:

(a) The cases shall have priority in the order of their respective filing dates;

(b) All claims properly based upon the disclosure of the earlier application, Serial No. 339,230 shall be included therein; and

(c) Claims not supported by the disclosure of said earlier application, but supported by the present disclosure are included in the present application.

Other objects and advantages inherent in my invention will become apparent from an examination of the accompanying drawings, and will be further set forth in the following description. In the drawings, in which like parts are designated by like numerals:

Fig. 1 is a perspective view of my invention shown installed in a window opening and indicating certain portions thereof broken away in order to show more clearly the structural relationship of the parts comprising my invention;

Fig. 2 is a plan view of the upper or condenser unit with certain portions cut away and in horizontal section;

Fig. 3 is a fragmentary vertical cross-sectional view taken on line 3-3 of Fig. 2;

Fig. 4 is an enlarged view of one end of the cable unit comprising an important structural element of my invention; and

Fig. 5 is a cross-sectional view taken substantially on line 5-5 of Fig. 4.

Referring to the various views, the apparatus of my invention is generally designated 9, and consists of a condensing unit 10, connected to a compressor unit generally designated 11, by means of a flexible cable element designated 12.

The condensing unit 10 is provided with a fan assembly 22 having a male electrical connection 22' to which is connected the double female electrical plug 23 attached to an electrical wire connection 24, the other end thereof having secured thereto a male plug not shown in the drawing, suitable for connecting the entire air condition-

ing unit to an electrical source of supply or an electrical socket.

Within the cable 12, which is made of flexible material, are the flexible gas conduits 26 and 27 terminating in unions 28, 29, 30 and 31, for suitably connecting the condensing unit 10 to the compressor unit 11. Within the said cable 12 is also contained an electrical wire connection 36, having a suitable male plug adapted to be secured to one of the outlets of the female plug 23; and in like manner at the other end of the wire 36, there is provided a female plug 37 adapted to be connected to the prongs 38, which in turn are connected to switches 46 and 39, in order to control the operation of the device. A pair of condensate conduits designated 50 and 51 and terminating in unions 52, 53, 54 and 55 are also contained in the flexible cable 12.

Within the compressor unit 11, there is indicated a compressor 42, and a relay 43, as well as a cooling coil assembly 41. In the condensing unit 10, is also shown a coil assembly 44, interconnected in order to circulate the gases through the flexible conduits 26 and 27, the same being connected by virtue of the union connections 28, 29, 30 and 31, as heretofore mentioned.

During its normal operation, the cooling coil or evaporator assembly 41 in which the refrigerant expands in the usual manner is effective not only to cool air which is blown past this cooling coil, but also to condense out of this air some of the moisture content thereof. A drain pan 56 is provided below this cooling coil assembly to receive condensate. As shown, it is usually preferred that this drain pan shall contain some absorbent material 57, as a sponge. This in practice prevents the condensate from splashing about possibly due to vibration of the motor-compressor unit or from any other cause. After the absorbent material 57 is substantially saturated, some condensate may flow through a tube 58 to a water pump 59 driven possibly by the same source of mechanical power as the refrigerant compressor or by a separate motor and connected to force the condensate through a feed conduit 50, which is connected as shown in Fig. 2, to a perforated nozzle or tube 62 disposed in the upper portion of the unit 10 (see Figs. 2 and 3). There is provided below the nozzle or tube 62 an elongate well 60, which is provided with an absorbent mass 61, as a sponge. Condensate supplied through the nozzle or tube 62 is taken up in the absorbent material 61 and thence may pass dripwise through an opening 63 as shown in Fig. 3 onto the coil of the condenser coil assembly 44. The condensate thus delivered to the well 60 is prevented from undesired splashing around by the absorbent mass 61 and is delivered dripwise onto the coil assembly 44 in a substantially uniform manner irrespective of any irregularities in the rate of supply of condensate to the absorbent mass 61. The condensate may be evaporated as it flows over the condenser coil of the assembly 44 incident to the flow of air past this coil. In evaporating, it helps cool the condenser coil as well as to dispose of this condensate in a manner which will prevent such condensate from running down the outside of the building in which the device is installed and causing unsightly streaking of the building and/or annoyance to passersby. Any condensate not so evaporated may collect in a lower well or drain pan 66 below the condenser coil and may flow back through a return line 51 to be recirculated by the pump 59. Under normal circumstances, it is contemplated that all the condensate will be recirculated until it is evaporated as aforesaid. Any excess, perhaps a small amount, of condensate which is not so evaporated may pass through overflow openings 64 in the pan 66 and will be disposed of through drain openings 65 out-

3

side of the window sill. The refrigerant gas is circulated from the compressor 42 through the coil assembly 41 and upwardly through the condensing unit coil assembly 44 and returned through the gas conduits 26 and 27.

For safety purposes I provide a flexible wire cable 33, having eyes 34 at each end thereof, to be releasably secured to the snap locks 35, said locks having terminal straps 32 for securing them to the walls of the condensing unit 10 and the walls of the compressor unit 11 respectively. Thus if the condensing unit 10 were to be dropped in handling to fall outside the confines of the room, namely, outside the window, it would not drop and be damaged or injure someone who might be passing therebelow.

The condensing unit 10 can be separated in use a limited distance from its other component, the compressor unit 11, so that the condensing unit 10 may be placed between the window frame 20 and the sash frame 17, to rest on the window sill or ledge 45, with one end thereof against the side of the window frame 20, the opening 18 remaining being sealed by a sliding transparent organic plastic shutter 19. A slotted section 21 in the cabinet of unit 10 permits the shutter 19 to be extended to operative position or retracted when not in use. An angle iron 16 stabilizes the unit 10 against the sash frame 17, thus holding the assembly rigidly in place.

The condensing unit 10 has a fan assembly 22 and a condensing coil 44 as aforesaid. The compressor unit 11 has a fan assembly 40 and a coil assembly 41, the coil assemblies 41 and 44 and the compressor 42 being interconnected by the conduits 26 and 27 in a conventional manner, so as to form a continuous passageway for the gases which are liquefied and volatized to absorb the heat from the air circulated thereabout, resulting in the air conditioning cycle of operation.

The flexible cable 12 permanently connects the units 10 and 11 and contains the wire 36 for electrical connection to operate the fan assemblies 40 and 22, the compressor 42 as well as the pump 59.

The electrical wiring diagram interconnecting all elements electrically is not included per se, but the principles thereof have been generally indicated in this description, the mechanism for air conditioning being of conventional arrangement, and the specific details thereof not being materials of the present invention.

The compressor unit 11, which is the heavier of the two units, may (in a preferred embodiment of the invention) weigh about 125 lbs. and is supported on casters 13, so that it may be moved about on the floor 14 to any desirable window location in the room or in an apartment, at which time the unit 10 rests in the recess provided by the frame 47 on top of the compressor unit 11. The unit 10 may (in the same preferred embodiment) weigh about 10 lbs.

The advantage of the present invention lies in the fact that the air conditioner is made up of a relatively heavy unit 11, which is mobile and may be moved from place to place, and a component or complementary relatively light weight window receiving unit 10, so that it can be readily lifted and installed. The entire combination may thus be moved readily and easily from room to room, or from window to window, as desired.

An important feature of my invention is in the disposition of the condensate present as a consequence of the operation of air conditioning equipment, almost the entire condensate is circulated and recirculated during the operation of my invention.

Although the drawings and the above specification disclose the best modes in which I have contemplated embodying my invention, I desire to be in no way limited to the details of such disclosure, for in the further practical application of my invention many changes in the form and construction thereof may be made as circumstances require or experience suggests without departing

4

from the spirit of the invention as expounded within the scope of the appended claims.

Having thus described and revealed my invention, what I claim as new and desire to secure by Letters Patent is:

1. In combination with a room air-conditioning means, including a condenser unit adapted in its normal operation to be positioned at least partly outside a window of a room to be air-conditioned by said means, said means including a motor-compressor unit for a refrigerant, a closed refrigerant system including the compressor of said unit, a condenser coil forming a part of said condenser unit and arranged outside said room, and an evaporator coil arranged inside said room; a drip pan beneath said evaporator coil to receive condensate water, means to receive water from said drip pan and to discharge it onto said condenser coil, so that evaporation of this water on the outside of said condenser coil will assist in cooling the condenser coil, a drip pan below said condenser coil for water which is not evaporated in a single passage past said condenser coil, and means for conducting water from the second named drip pan to said means to discharge water onto said condenser coil, so that water not evaporated as aforesaid may be recirculated past said condenser coil.

2. The combination in accordance with claim 1, in which at least one of said drip pans is provided with a filling of absorbent material for retaining condensate water therein and preventing such water from splashing out of such drip pan.

3. In combination with a room air-conditioning means, including a condenser unit adapted in its normal operation to be positioned at least partly outside a window of a room to be air-conditioned by said means, said means including a motor-compressor unit for a refrigerant, a closed refrigerant system including the compressor of said unit, a condenser coil forming a part of said condenser unit and arranged outside said room, and an evaporator coil arranged inside said room; a drip pan beneath said evaporator coil to receive condensate water, means to receive water from said drip pan and to discharge it onto said condenser coil, so that evaporation of this water on the outside of said condenser coil will assist in cooling the condenser coil, said water discharge means including a well chamber arranged above said condenser coil for receiving condensate from said drip pan, absorbent material in said well chamber, passage means in the bottom of said well chamber through which water may pass onto said condenser coil, said well chamber and its associated absorbent material serving to supply condensed water dripwise and in a substantially uniform manner onto the outside of said condenser coil, irrespective of variations from time to time in the rate of supply of condensate water to said well chamber, a drip pan below said condenser coil for water which is not evaporated in a single passage past said condenser coil, and means for conducting water from the drip pan below said condenser coil to said means to receive and discharge water, so that water not evaporated as aforesaid may be recirculated past said condenser coil.

4. The combination in accordance with claim 3, comprising in addition, absorbent material substantially filling said drip pan below said condenser coil, and an overflow passage arranged above the bottom of the last named drip pan for the overflow of any water therefrom which may flow out of said overflow passage after the absorbent material in said last named drip pan has been substantially saturated.

5. The combination in accordance with claim 3, comprising in addition, absorbent material substantially filling said well chamber as aforesaid and other absorbent material filling said drip pan below said condenser coil, so as to minimize the possibility of water in liquid form splashing out of either said well chamber or the last named drip pan as long as the capacity of said condenser

5

coil to evaporate water supplied onto the outside thereof as aforesaid is adequate to evaporate all the condensate water removed from the air by the air-conditioning means.

References Cited in the file of this patent

UNITED STATES PATENTS

2,145,776 Muffly ----- Jan. 31, 1939

2,181,213
2,185,387
2,251,960
2,362,698
5 2,472,792
2,583,149

6

Smith ----- Nov. 28, 1939
Weiland ----- Jan. 2, 1940
Smith ----- Aug. 12, 1941
Hull ----- Nov. 14, 1944
Cohler ----- June 14, 1949
Malkoff ----- Jan. 22, 1952