

Dec. 14, 1948.

T. T. GOLDSMITH, JR., ET AL

2,455,992

CATHODE-RAY TUBE AMUSEMENT DEVICE

Filed Jan. 25, 1947

2 Sheets-Sheet 1

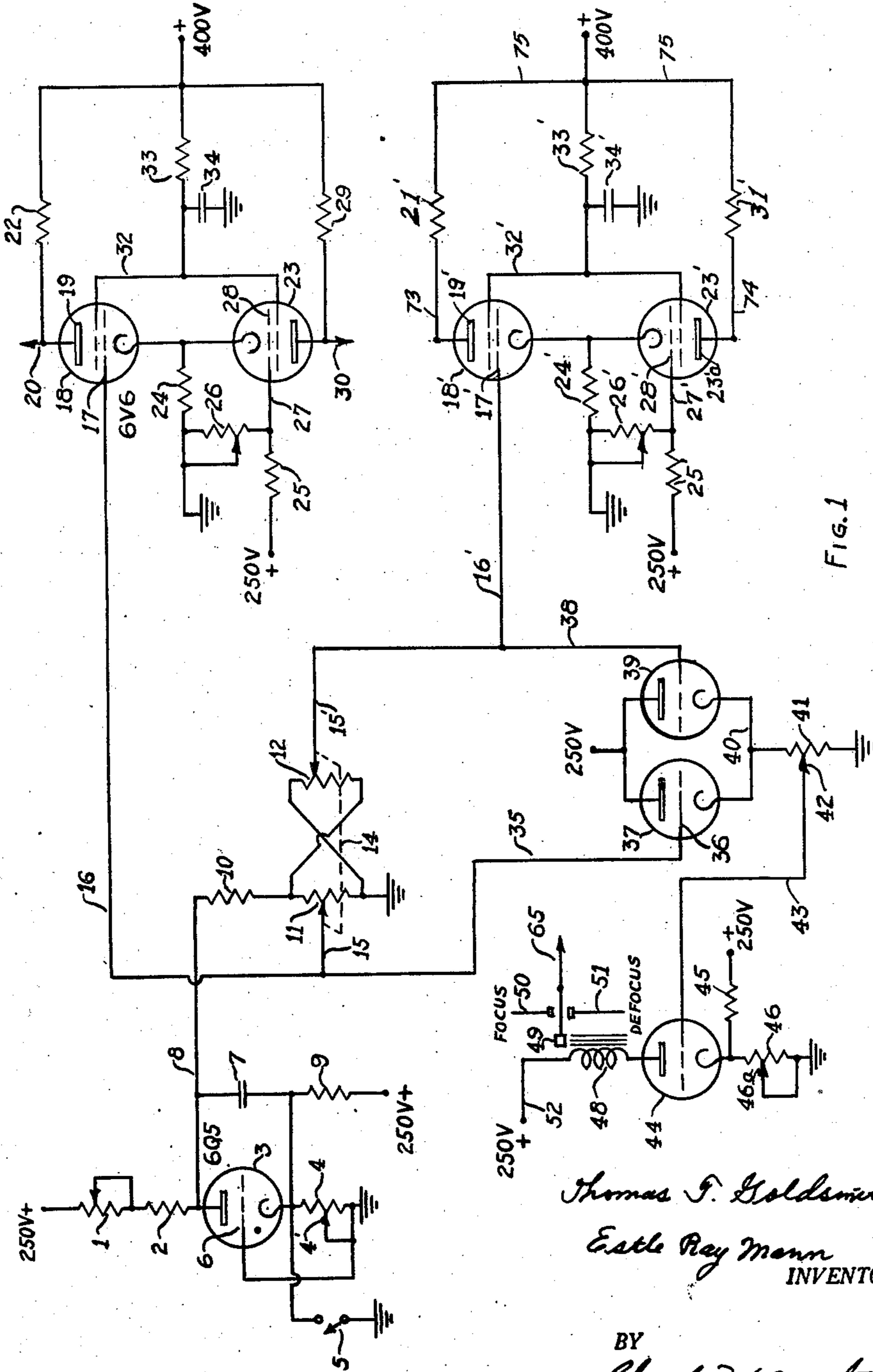

FIG. 1

Thomas T. Goldsmith, Jr.
Estle Ray Mann
INVENTORS

BY
Charles W. Mortimer

Dec. 14, 1948.

T. T. GOLDSMITH, JR., ET AL
CATHODE-RAY TUBE AMUSEMENT DEVICE

2,455,992

Filed Jan. 25, 1947

2 Sheets-Sheet 2

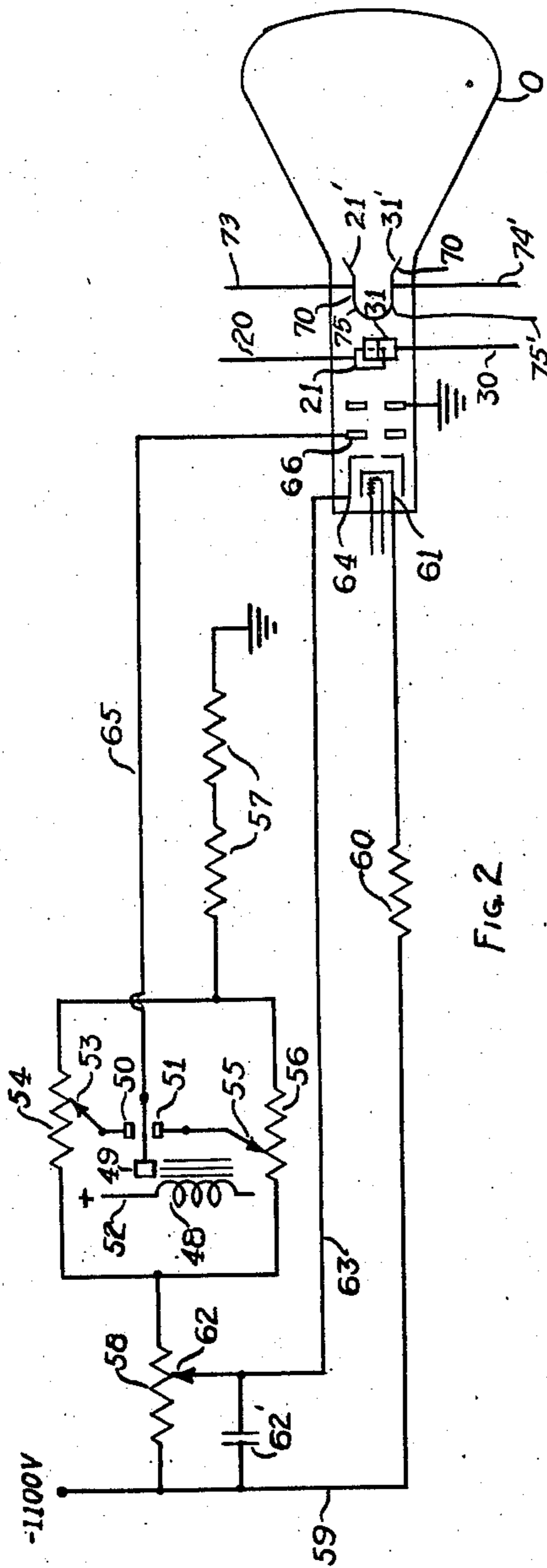

FIG. 2

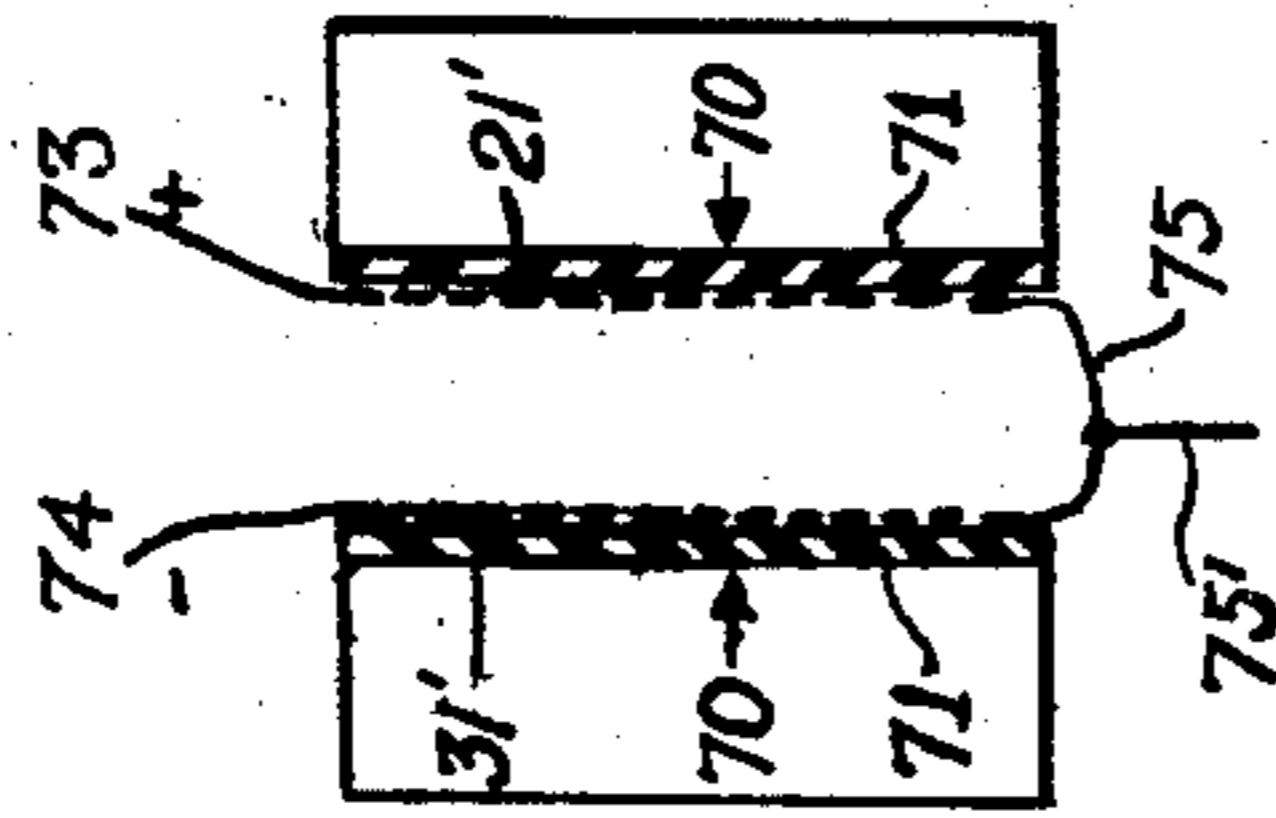

FIG. 3

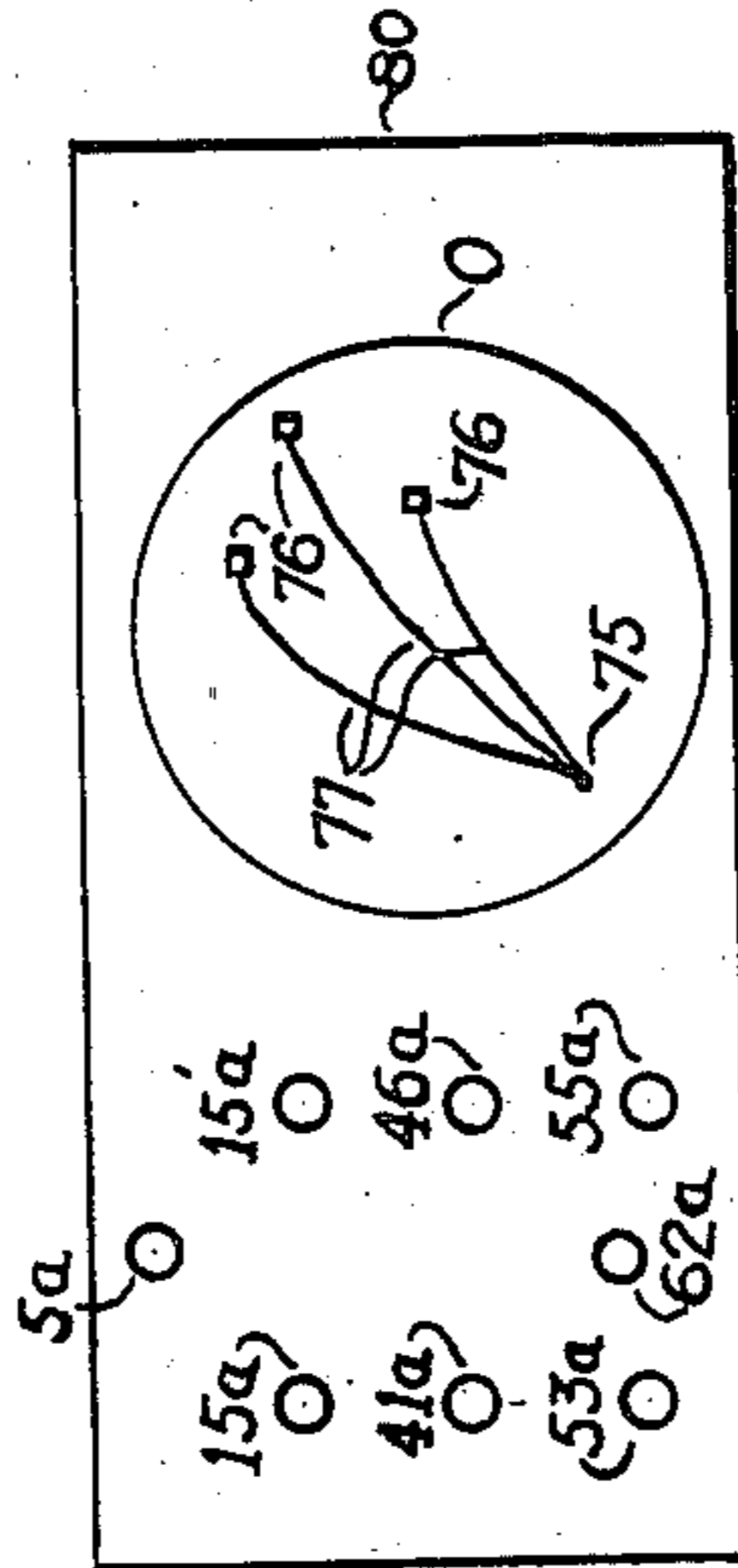

FIG. 4

Thomas T. Goldsmith, Jr.
Estle Ray Mann, INVENTORS

BY
Charles W. Montimer

UNITED STATES PATENT OFFICE

2,455,992

CATHODE-RAY TUBE AMUSEMENT DEVICE

Thomas T. Goldsmith, Jr., Cedar Grove, and Estle Ray Mann, Upper Montclair, N. J., assignors to Allen B. Du Mont Laboratories, Inc., Passaic, N. J., a corporation of Delaware

Application January 25, 1947, Serial No. 724,444

6 Claims. (Cl. 315—26)

1

This invention relates to a device with which a game can be played. The game is of such a character that it requires care and skill in playing it or operating the device with which the game is played. Skill can be increased with practice and the exercise of care contributes to success.

In carrying out the invention a cathode-ray tube is used upon the face of which the trace of the ray or electron beam can be seen. One or more targets, such as pictures of airplanes, for example, are placed upon the face of the tube and controls are available to the player so that he can manipulate the trace or position of the beam which is automatically caused to move across the face of the tube. This movement of the beam may be periodic and its repetition rate may be varied. Its path is preferably caused to depart from a straight line so as to require an increased amount of skill and care for success in playing the game.

The game can be made more spectacular, and the interest therein both from the player's and the observer's standpoint can be increased, by making a visible explosion of the cathode-ray beam take place when the target is hit.

The invention may be understood from the description in connection with the accompanying drawings, in which:

Fig. 1 is a diagram of electrical connections suitable for operating the device;

Fig. 2 is a diagram on an enlarged scale, showing some of the details of Fig. 1 and additional elements;

Fig. 3 is a diagram showing some of the details of a pair of deflecting plates; and

Fig. 4 shows the end of a cathode-ray tube, and suitable controls for operating the device.

In the drawings, reference character 1 indicates a variable resistor that is in series with a fixed resistor 2. These resistors are fed from any convenient source of positive potential. They are the load resistors of the thyatron 3 which has a variable resistor 4 in its cathode circuit. A switch 5 is provided for short-circuiting the resistor 4, thus firing the thyatron manually whenever desired for a purpose to be explained later. The grid 6 of the thyatron 3 is connected to ground. The condenser 7 together with variable resistor 1 and fixed resistor 2 gives the desired time constants for the sawtooth wave which is the output on lead 8 that is connected to the plate of the thyatron 3. Resistor 9 in series with the variable resistor 4 is used for setting or fixing the positive voltage of the cathode of thyatron 3.

An attenuating resistor 10 is provided in the

2

lead 8. This resistor 10 is in series with the resistors 11 and 12 which are in parallel with each other and have one end of each grounded. Resistors 11 and 12 are ganged to a common control 14 as indicated by the dotted line so that as one contactor 15 is moved toward ground the other contactor 15' is moved away from ground. The movable contactor 15 on resistor 11 is connected by lead 16 to the control grid 17 of tube 18 which is part of a balanced phase inverter deflection amplifier which is to be described below.

The plate 19 of tube 18 is connected by lead 20 to one of the vertical deflection plates 21 of the cathode-ray tube mentioned above and which is indicated at O in Fig. 2. The load resistor for tube 18 is resistor 22.

The cathode of tube 18 is connected to the cathode of tube 23 which is another tube of the balanced deflection amplifier mentioned above. A resistor 24 connects the cathodes of tubes 18 and 23 to ground. Resistor 25 and a variable resistor 26 are connected in series between a source of positive potential and ground. Lead 27 connects a point between resistors 25 and 26 to the control grid 28 of tube 23. The plate load of this tube is resistor 29, and the plate of this tube is connected by lead 30 to the other vertical deflection plate 31 of the cathode-ray tube O. The screen grids of tubes 18 and 23 are connected together by lead 32. This lead is connected by resistor 33 to the source of positive potential, and a capacitor 34 is connected between this resistor 33 and ground.

The amplifier for the horizontal deflection plates of tube O is like the one just described, corresponding parts being designated by the same reference characters with primes. However, the plate load resistors 21' and 31' of the two vacuum tubes 19' and 23' differ from resistors 22 and 29. These load resistors 21' and 31' are high resistance coatings on the two horizontal deflection plates of the cathode-ray tube O which will be described later.

Lead 35 from contactor 15 extends to the grid 36 of tube 37. The plate of this tube is connected to a regulated power supply which may be at 250 v. Lead 38 from the contactor 15' on resistor 12 extends to the grid of tube 39. The plate of this tube is also connected to the regulated power supply. The cathode of tube 37 is connected to the cathode of tube 39 by lead 40 which is grounded through resistor 41. A sliding contact 42 on resistor 41 is connected by lead 43 to the grid of tube 44. The cathode of tube 44 is connected through resistor 45 to a source of

positive potential, and this cathode is also grounded through a variable resistor 46. The plate load of the tube 44 is the field coil 48 of a single-pole spring-biased relay. Contactor 49 is spring biased so that as long as this coil is not energized the contactor 49 of this relay is caused to contact with the contactor 50 to focus the beam of the cathode-ray tube O, as explained more fully below. When the coil 48 is energized by current passing through tube 44 contactor 49 is caused to contact with the contactor 51. This defocuses the beam of the tube O. A positive voltage is applied to the lead 52 that is connected to coil 48. Contactor 50 is connected to a sliding contact 53 (Fig. 2) which slides on resistor 54, and contactor 51 is connected to a sliding contact 55 on resistor 56. The resistors 54 and 56 are connected in parallel. Resistor 57 is connected between one end of the resistors 54, 56 and ground, and resistor 58, which is connected to a source of negative potential, is connected between the other ends of these resistors opposite resistor 57. This source of negative potential is connected through lead 59 and resistor 60 to the cathode 61 of the cathode-ray tube O. A sliding contactor 62 on resistor 58 is coupled by condenser 62' to the lead 59. This sliding contactor 62 is connected by lead 63 to the control grid 64 of the cathode-ray tube O. The contactor 49 is connected by lead 65 to the focussing anode 66 of this cathode-ray tube.

The purpose of contactor 49 and its attendant circuits is to provide the operator with means for de-focussing the beam in the tube O at some previously determined position of the spot on the screen, this previously determined position being controlled both by the variable resistor 46 (Fig. 1) and the sliding contact 42.

The cathode-ray tube O is similar to well known cathode-ray tubes. However, the pair of deflection plates for producing horizontal deflection of the beam is different from deflection plates previously used. The vertical deflection plates are the same as those normally used in cathode-ray tubes. Each of the horizontal deflection plates 70 consists of a non-conducting base or plate, or support 71 (Fig. 3), similar in shape to the present horizontal deflection plates.

High resistance conducting material 21' and 31', such as aquadag, is applied to the inner surface of each of these plates as shown by dotted lines in Fig. 3. The resistance from the lower edge to the upper edge of each conducting layer may, for example, be approximately 30,000 ohms. The cathode-ray tube O is assumed to be mounted with its axis horizontal. The upper ends of these high resistance materials 21' and 31' are in contact with conductors 73 and 74. The lower edges thereof are connected by conductor 75. By lead 75' either through the base or through the glass of the tube O positive potential is applied to conductor 75. The outer ends of the conductors 73 and 74 are connected by leads either through the base or through the glass of the tube O to plates 19' and 23'a (Fig. 1) so that the difference of potential between the two plates 70 (Fig. 3) is greatest at the edges opposite the conductor 75. The electrostatic field between the two plates increases as the distance from the conductor 75 increases.

As the electrons of the cathode-ray or beam pass between the vertical deflecting plates 21, 31 (Right hand portion of Fig. 2) described above, the beam is deflected vertically by the sawtooth voltage which is applied to these plates. After

this vertical deflection, as these electrons proceed along the tube they pass between the horizontal deflecting plates 70. Since the field between these horizontal plates increases as the distance from the conductor 75 at the lower edge increases, due to the potential drop along the resistors 21', 31' (Fig. 3) on these plates, the greater the vertical deflection the greater will be the horizontal deflection.

The operation is as follows:

The switch 5 is closed, whereupon sawtooth voltage is applied to resistors 11 and 12.

The sawtooth signals are taken off by the sliding contactors 15 and 15' and are impressed simultaneously on the grids of tubes 37 and 39. The output of these tubes is taken from the common cathode load resistor 41 by adjustable contactor 42 and lead 43. This output is impressed on the grid of vacuum tube 44 through lead 43. Vacuum tube 44 is adjusted by variable resistor 46 in its cathode circuit and has a positive potential applied through resistor 45 to its cathode so that this cathode is sufficiently positive to make this tube normally non-conducting. When no current flows through coil 48 the relay 49 (Figs 1 and 2) is spring-pressed into contact with the contactor 50. This contactor 50 is connected to the sliding contactor 53 (Fig. 2) on resistor 54, which is manually adjusted to the position at which the spot on the cathode-ray tube O is sharply focussed due to the fact that the focus electrode 66 is then connected by lead 65 to contactor 50.

When the current through resistor 41, Fig. 1, is sufficiently high to cause the potential on the grid of tube 44 to start the plate current in this tube, the plate current which varies in a sawtooth wave manner passes through the coil 48 and when of sufficient strength brings contactor 49 into contact with contactor 51, Figs. 1 and 2. The sliding contactor 55 is adjusted on resistor 56 so that it causes the beam on the cathode-ray tube O to be considerably out of focus when the contactor 49 is connected to it by contactor 51, so that instead of there being a sharp spot to trace a pattern on the screen of tube O, there is a large round spot which is not nearly as bright as it would be if the beam were a sharply focussed image.

When a sawtooth voltage on lead 8 (Fig. 1) is impressed in phase upon both balanced phase-inverter deflection amplifiers 18, 23 and 18', 23' as shown in Fig. 1, the trace of the beam on the screen of tube O is parabolic. If there were no difference of potential from one edge to the other on the deflection plates, then the deflection due to sawtooth voltages would cause a straight line to appear on the screen. The axis of the parabolic path traced on the screen of the cathode-ray tube O as well as the location of this tracing can be controlled by the common control 14 (shown by a dotted line in Fig. 1).

The device may be placed in any suitable cabinet with the face of the tube O visible through an opening in the front panel thereof. Buttons or knobs for operating the controls may also be mounted on this panel.

In playing a game with this device the player takes a position where he can see the face of the tube O, Fig. 4. The end of the beam is at the spot 75 so long as the switch 5 is open. The object is to cause the beam to be deflected in such a manner that it will strike a selected one of the objects 76 on the face of the tube and become defocussed just as it reaches said object

76, thus simulating destruction or explosion of the object which may be represented as an airplane, for example. The paths 77 of the spot depend upon the potentials applied to the plates 21, 31, and 21', 31' which the player can control by adjusting the contactors 15 and 15' on resistors 11 and 12, Fig. 1.

Knobs or buttons 5a, 15a, 15a', 41a, 46a, 53a, 55a and 62a are provided at any convenient place, such as upon the front of a cabinet 80 for the device where the player can reach them and watch the face of the tube O (Fig. 4). The knob 5a enables the player to close and open the switch 5 (Fig. 1 at the left) at will. When it is closed a trace 77 appears upon the face of tube O. The knobs 15a and 15a' operate the sliding contacts 15 and 15' (shown in the upper left hand portion of Fig. 1) which control the direction of the trace 77 of the beam from the starting point 75 along the face of the tube O. The controls 41a and 46a operate the sliding contacts 42 and 46a (bottom left Fig. 1) to control the point at which the cathode-ray beam that produces the traces 77 becomes defocussed or "explodes." The controls 53a and 55a operate the sliding contacts 53 and 55 (shown at the upper left hand portion of Fig. 2) which regulate the focussing and defocussing of the cathode-ray beam, and control 62a controls the contactor 62 which adjusts the negative potential that is applied to grid 64, thus controlling the brilliance of the trace.

The object of the game is for the player to adjust the controls within a specified predetermined interval of time so that one of the parabolic traces 77 of the beam will start from the gunner's position 75 and hit a selected target or airplane 76 and explode on the selected target.

What is claimed is:

1. In a device of the character described, an electrical circuit comprising a cathode-ray tube, adjustable means including a sawtooth wave voltage generator, a pair of adjustable resistors between the output of said generator and ground to cause the beam of said tube to sweep from a fixed point along different paths along the face of said tube and means to cause said beam to become defocussed at different positions of its sweep by the output from said voltage generator.

2. In a device of the character described, a sawtooth wave generator, a cathode-ray tube, means to vary the output voltage of said gener-

ator, means to obtain impulses from said generator to control the beam of said cathode-ray tube, a spring contactor operated by said output voltage to make and break contact between said generator and said contactor, and means to operate said contactor by the output of said generator.

3. In a device of the character described, a sawtooth wave generator, a cathode-ray tube, means to vary the output voltage of said generator, means to obtain impulses from said generator to control the beam of said cathode-ray tube, a spring contactor operated by said output voltage to make and break contact between said generator and said contactor, and means to control said contactor by the output of said generator.

4. In a device of the character described, a cathode-ray tube having a beam intensity control and vertical and horizontal deflecting plates, a sawtooth wave generator comprising a vacuum tube having a variable resistor in its cathode circuit, a switch in parallel with said resistor, a vacuum tube having its control grid connected to the output of said sawtooth wave generator, a relay operated by the output of said vacuum tube and adapted to connect a source of negative potential to said beam intensity control electrode of said cathode-ray tube.

5. The device of claim 4 in which at least one of said deflecting plates is coated with a high resistance material.

6. The device of claim 4 in which one pair of said deflection plates is coated with high resistance material and the plates of this pair are connected in series.

THOMAS T. GOLDSMITH, JR.
ESTLE RAY MANN.

REFERENCES CITED

The following references are of record in the file of this patent:

UNITED STATES PATENTS

Number	Name	Date
2,062,538	Van Den Bosch	Dec. 1, 1936
2,098,384	Goodrich	Nov. 9, 1937
2,179,097	Law	Nov. 7, 1939
2,313,018	Krause	Mar. 2, 1943
2,406,858	Shepherd et al.	Sept. 3, 1946
2,413,785	Robinette	Jan. 7, 1947
2,425,330	Kenyon	Aug. 12, 1947