

Jan. 28, 1947.

R. T. JAMES
TOY AND PROCESS OF USE
Filed Aug. 21, 1946

2,415,012

3 Sheets-Sheet 1

Fig. 1.

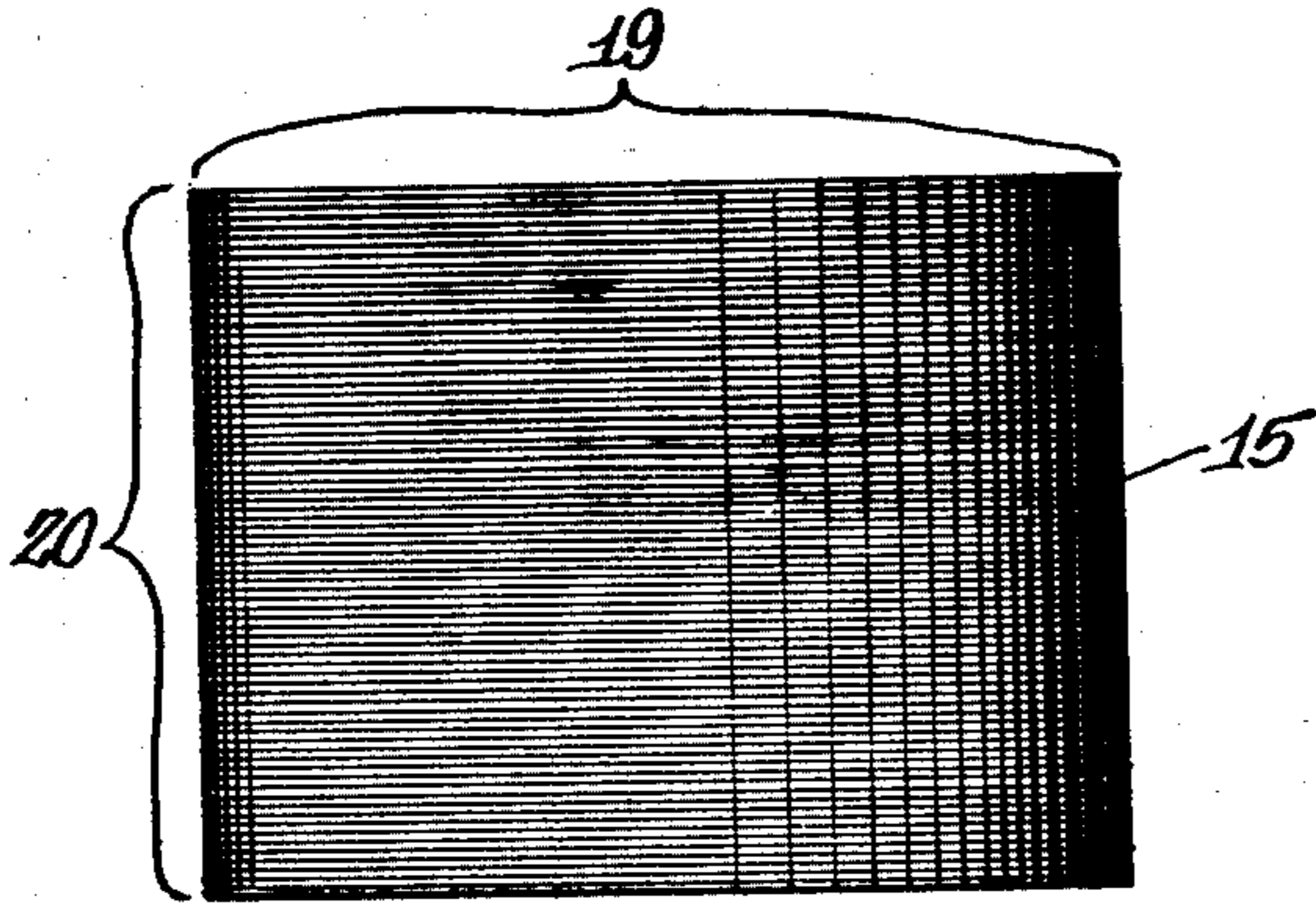

Fig. 2.

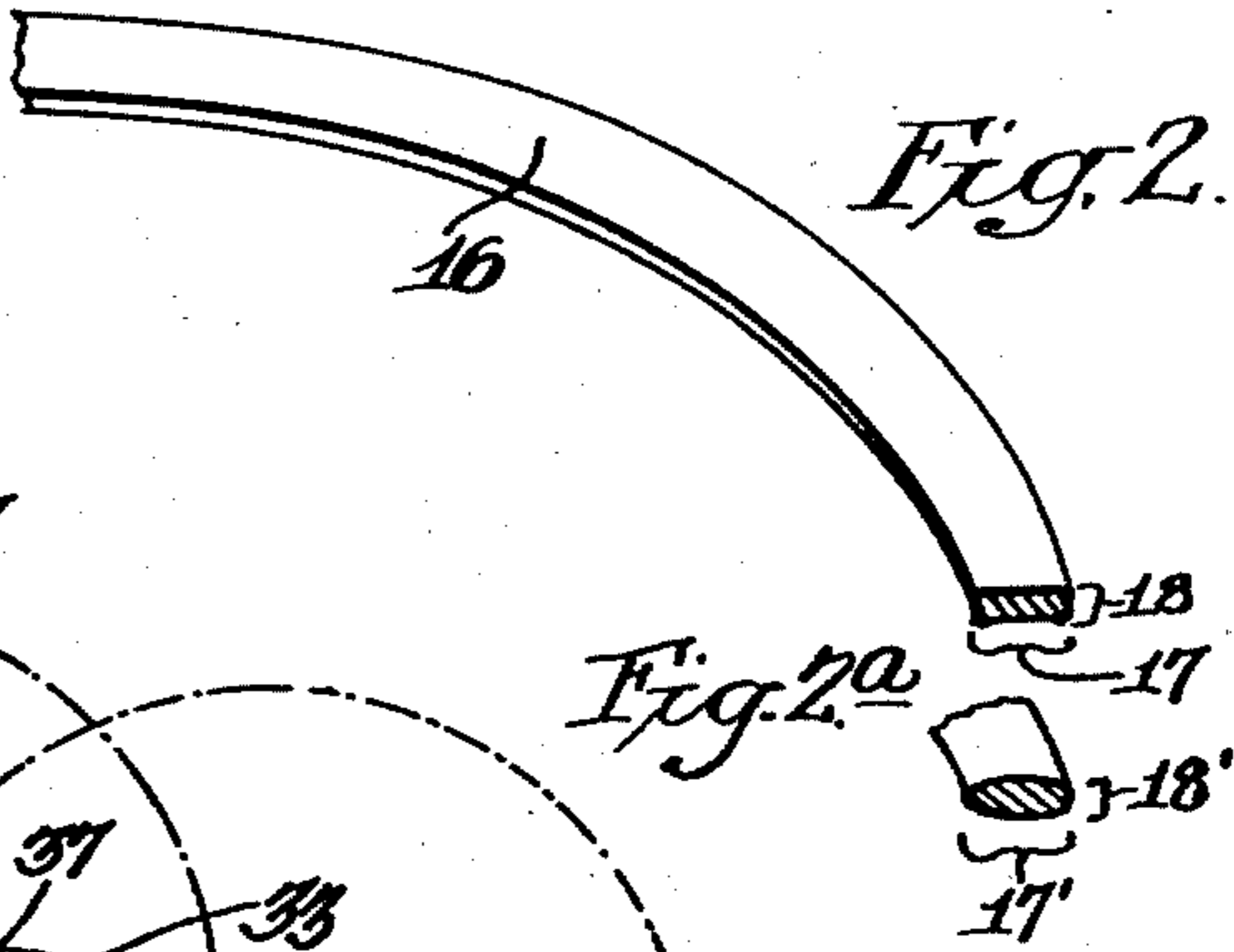

Fig. 6.

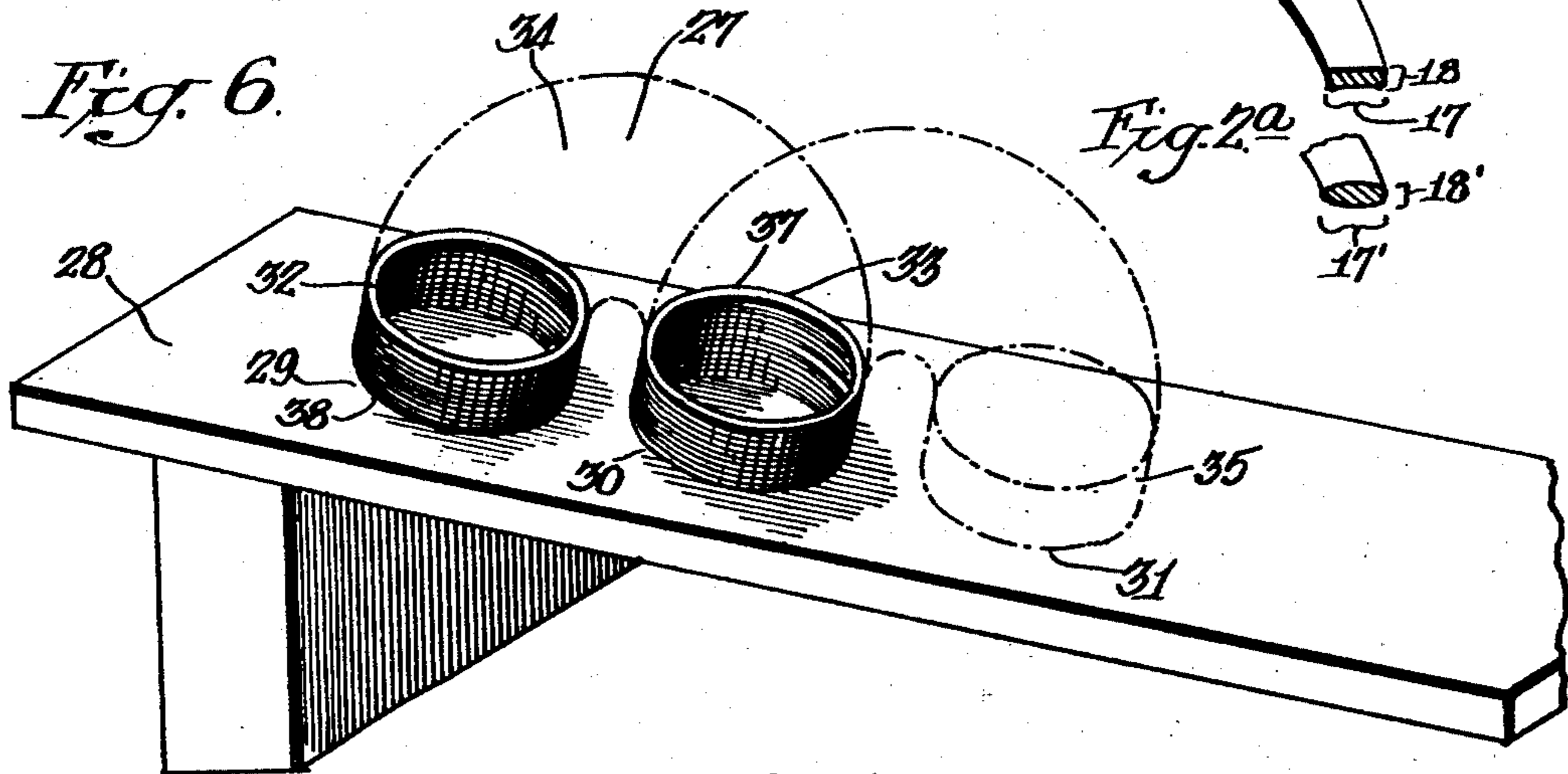

Fig. 8.

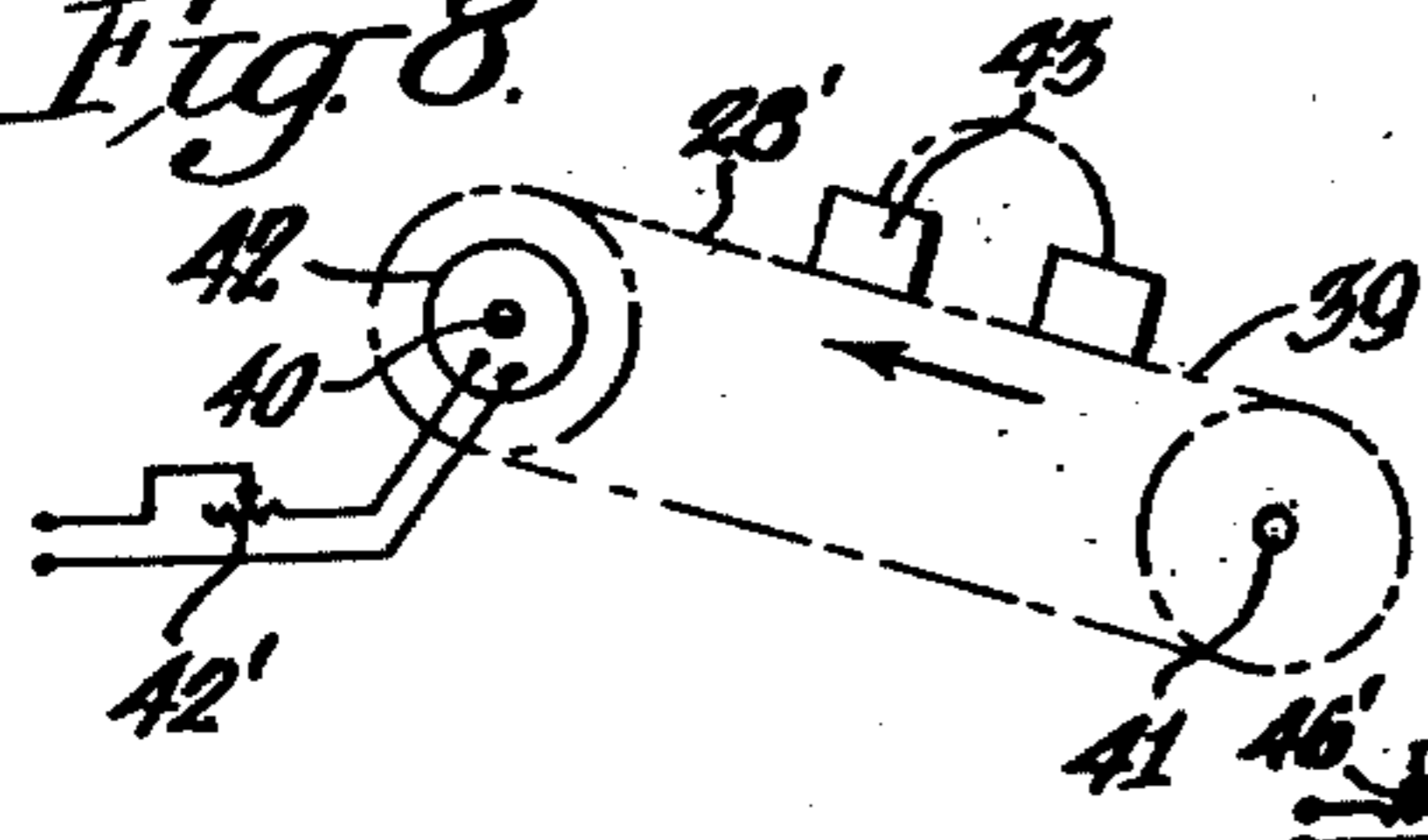
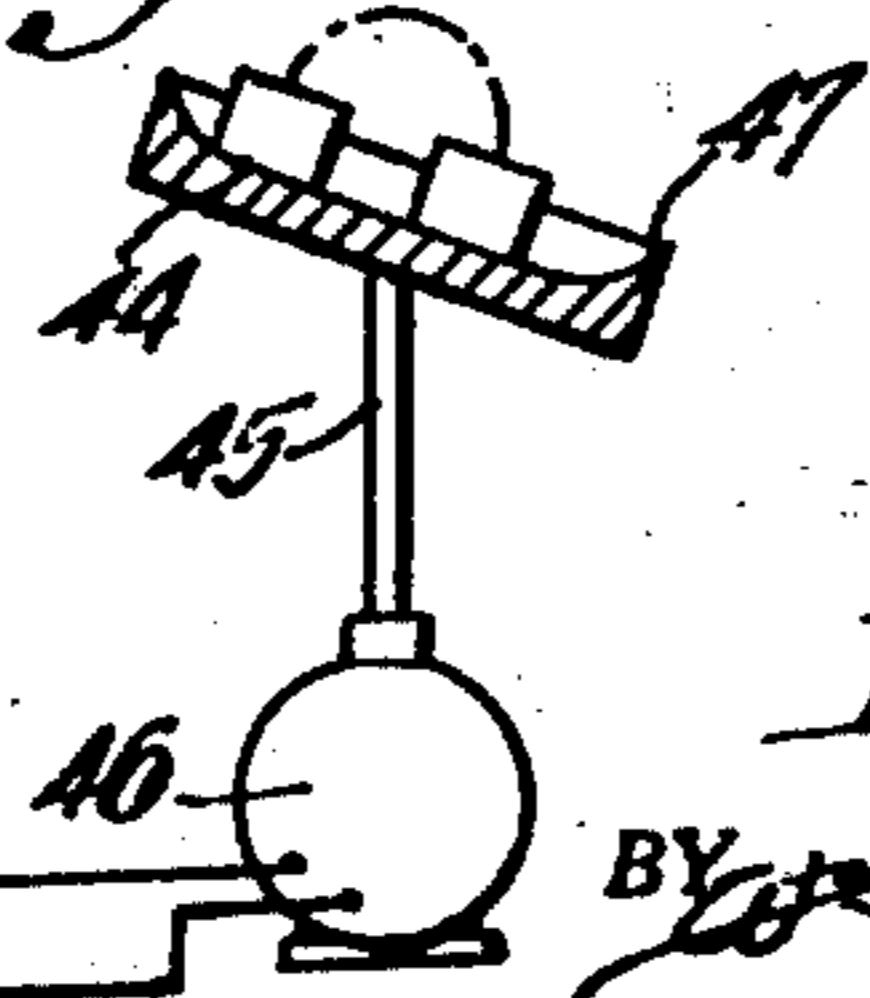

Fig. 9.



INVENTOR:
Richard T. James,
BY *W. Stall* ATTORNEYS.

Jan. 28, 1947.

R. T. JAMES

2,415,012

TOY AND PROCESS OF USE

Filed Aug. 21, 1946

3 Sheets-Sheet 2

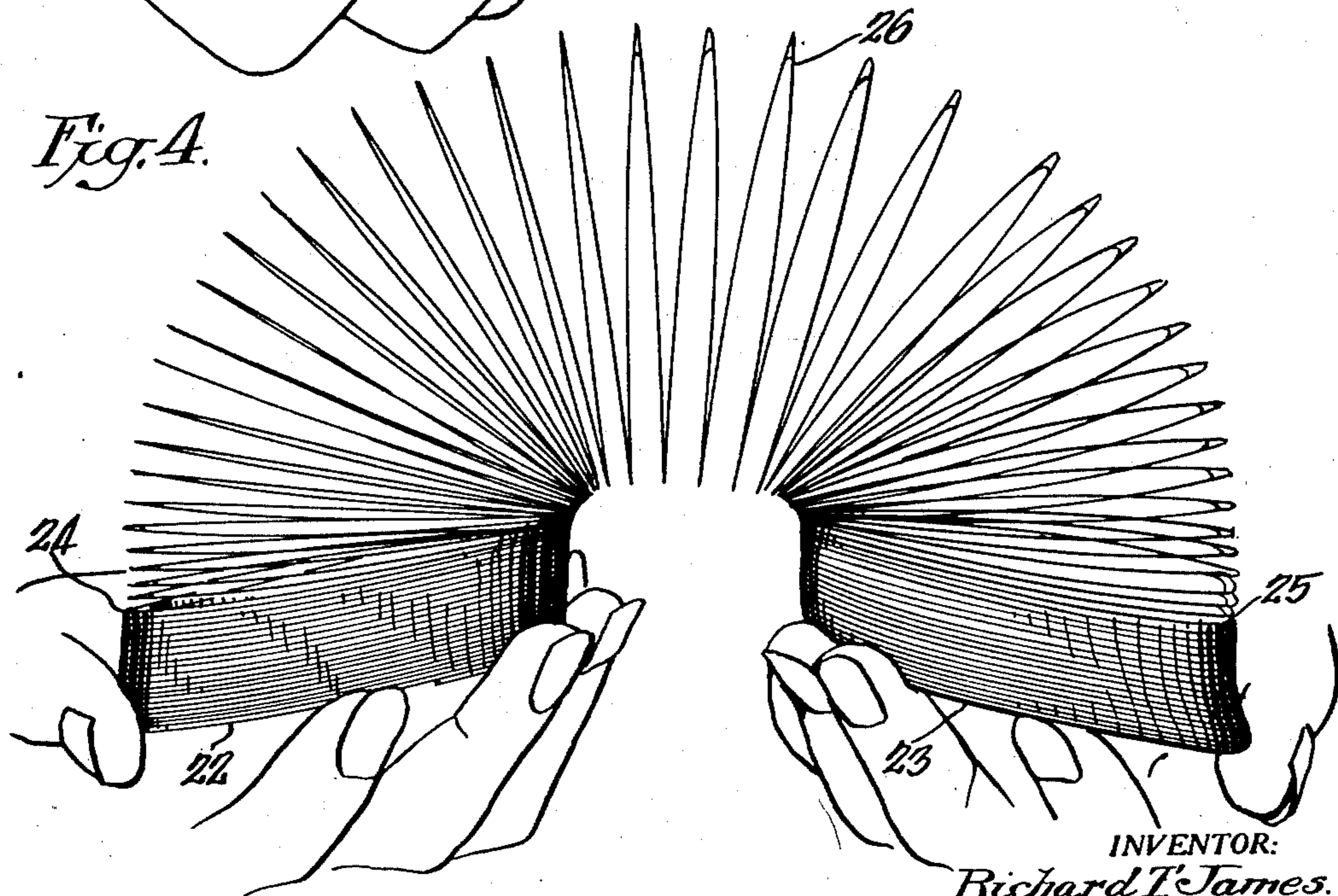
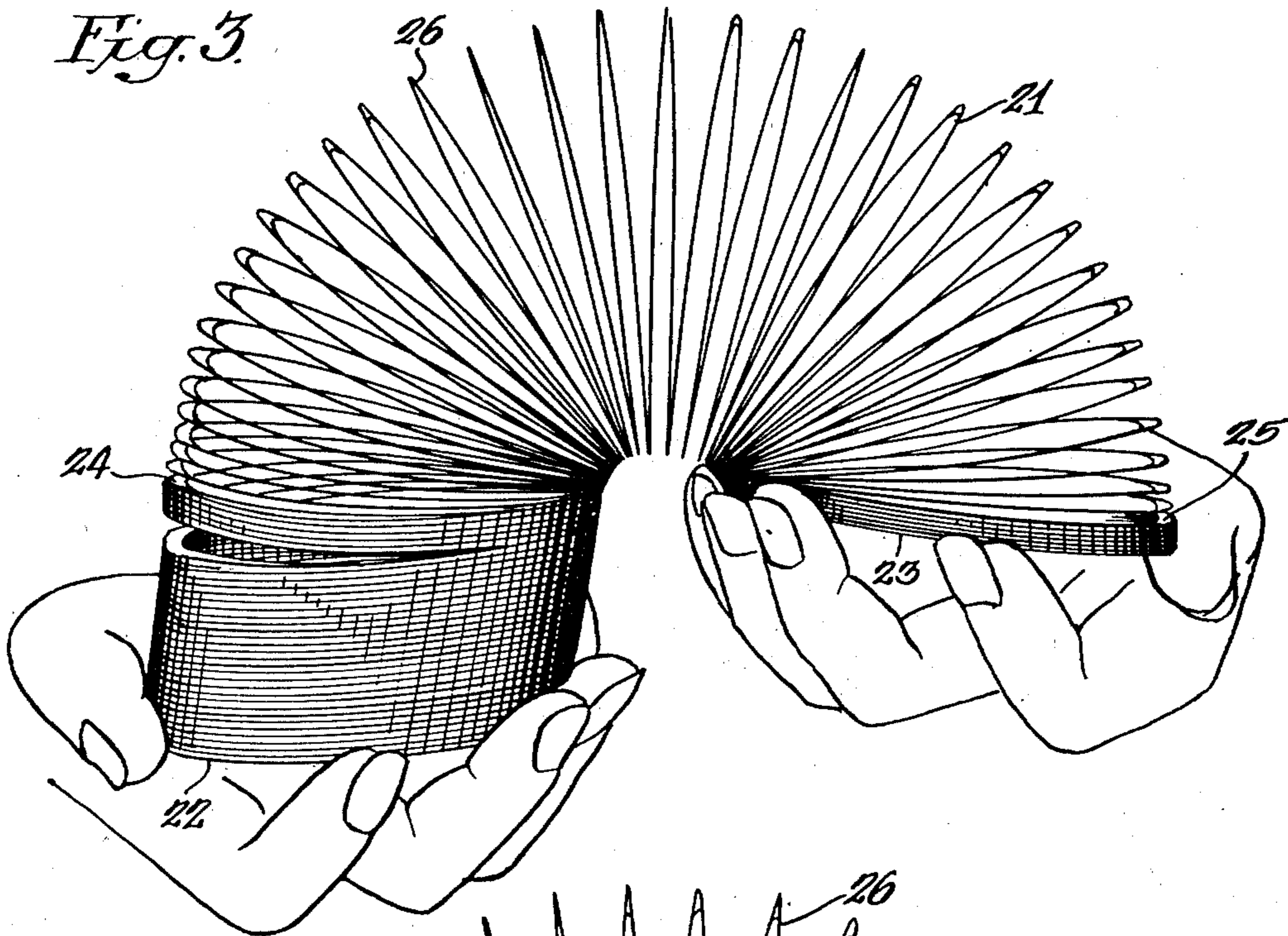

INVENTOR:
Richard T. James.
BY *W. Stull Speck* and Son
ATTORNEYS.

Jan. 28, 1947.

R. T. JAMES

2,415,012

TOY AND PROCESS OF USE

Filed Aug. 21, 1946

3 Sheets-Sheet 3

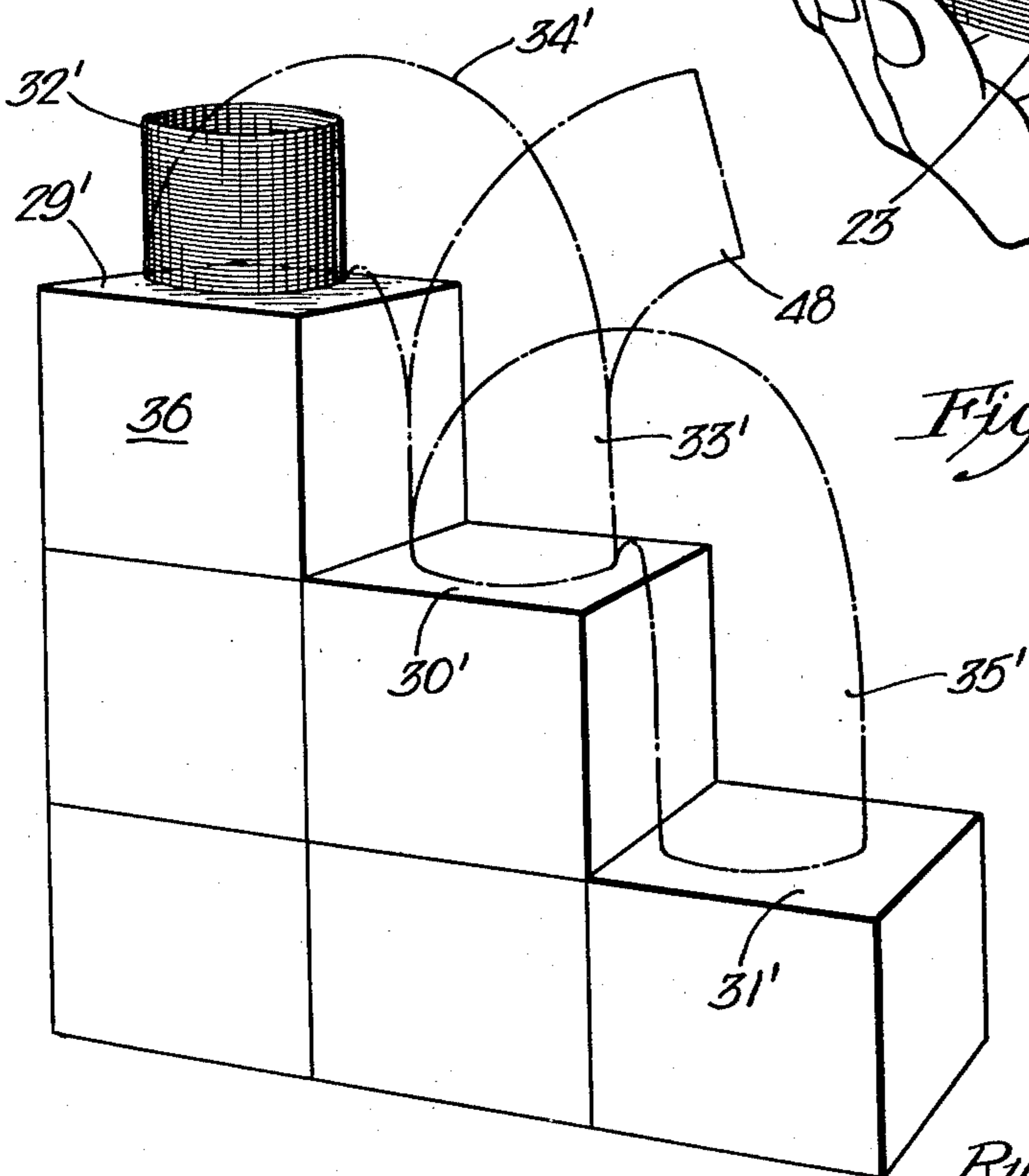
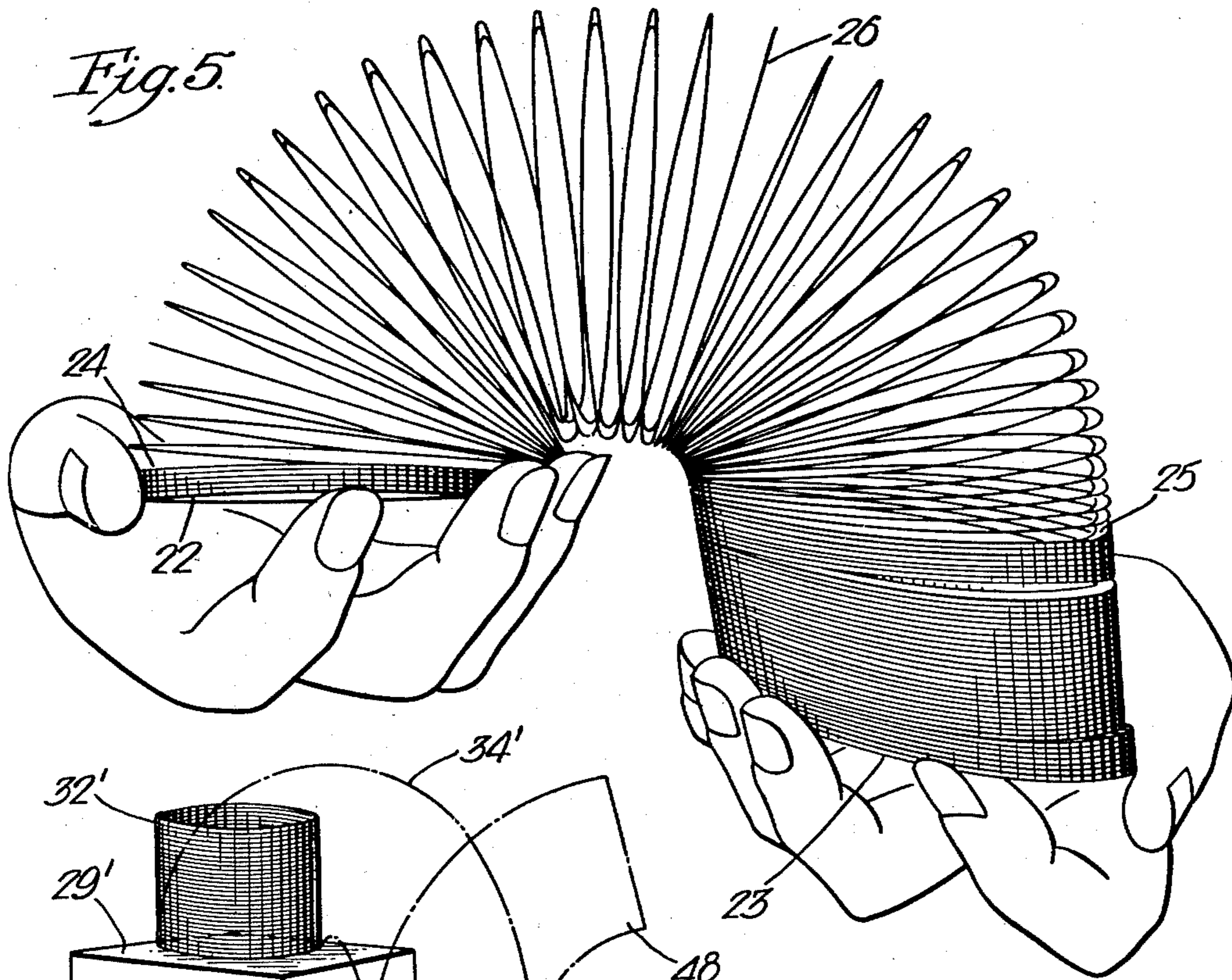

INVENTOR.
Richard T. James
BY
Wm. D. Jackson & Co.
Attorneys.

UNITED STATES PATENT OFFICE

2,415,012

TOY AND PROCESS OF USE

Richard T. James, Upper Darby, Pa., assignor to
James Industries, Inc., Philadelphia, Pa., a cor-
poration of Pennsylvania

Application August 21, 1946, Serial No. 691,981

19 Claims. (Cl. 46—1)

1

My invention relates to toys primarily in-
tended for amusement of children, but also for
family use as parlor games and the like, and for
advertising purposes.

A purpose of my invention is to provide a
helical spring toy which will transfer its turns
from one end to the other in an entertaining
manner when it is bent into general semi-circular
form and the ends are moved up and down.

A further purpose is to provide a helical spring
toy which will walk on an amusement platform
such as an inclined plane or set of steps from a
starting point to successive lower landing points
without application of external force beyond the
starting force and the action of gravity.

A further purpose is to design a helical spring
toy of essentially low natural frequency, suitably
between 10 and 100 cycles per minute, having
substantially no compression between turns in
closed position when no external force is acting,
and having dimensions and proportions which
permit manual handling.

A further purpose is to design a helical spring
toy adapted to walk and oscillate, consisting es-
sentially of a helical spring having substantially
no compression or tension between turns in closed
position when no external force is acting, and
in which the spring cross section has substan-
tially lower torsional stiffness than a square cross
section of the same cross sectional area, thereby
producing low natural frequency.

A further purpose is to design a helical spring
toy having substantially no compression or ten-
sion between turns when no external force is act-
ing, having a radial cross sectional dimension
between 1.1 and 10 times (preferably between 2
and 6 times, and most desirably about 4 times)
the axial cross sectional dimension, with an out-
side diameter of coil between 4 and 100 times
(preferably between 10 and 50 times, and most
desirably about 30 times) the radial cross sec-
tional dimension, and having a solid height be-
tween one-half and 5 times (preferably between
 $\frac{3}{4}$ and one and one-half times, and most de-
sirably equal to) the diameter, the coil being
capable of bridging an axial semi-circle without
external force holding it in position.

Further purposes appear in the specification
and in the claims.

This application is a continuation in part of my
application Serial No. 625,996, filed November 1,
1945, for Toy and process, copending herewith.

In the drawings I have chosen to illustrate one
only of the embodiments in which my invention
might appear, with a minor variation, the form

2

primarily shown being chosen from the stand-
points of convenience in illustration, satisfactory
operation and clear demonstration of the prin-
ciples involved.

Figure 1 is a side elevation of my helical spring
toy.

Figure 2 is a fragmentary sectional perspective
of part of a single turn of the coil.

Figure 2a is a fragmentary sectional perspective
of a variant coil cross section.

Figures 3, 4, and 5 are side elevations partly in
perspective showing successive steps in manipula-
tion of the toy by the hands.

Figure 6 is a partially diagrammatic perspec-
tive showing the toy walking down an inclined
plane.

Figure 7 is a partially diagrammatic perspec-
tive showing the toy walking down a set of steps.

Figures 8 and 9 are fragmentary diagrammatic
side elevations showing continuously operating
amusement platforms. In Figure 9 the amuse-
ment platform is shown in central vertical sec-
tion.

In the drawings like numerals refer to like
parts.

As shown in Figures 1 and 2, the helical spring
toy 15 has its individual turns 16 made up of
spring stock having a radial cross sectional
dimension or width 17 and an axial cross sectional
dimension or thickness 18. The outside diameter
of the coil is shown at 19 and the solid height of
the coil is shown at 20.

It is important for the present invention that
the coil be wound without any substantial com-
pression or tension (lateral force) in closed posi-
tion between the turns when no external force is
acting as in Figure 1. Thus in this figure the
turns are resting in lateral contact without the
necessity of any external compression other
than the weight of the turns, and the coils can
be extended slightly without overcoming any ap-
preciable internal force due to spring action.

While the toy of the present invention can be
manufactured from various materials as required,
it has been found that for best results a suitable
spring steel such as S. A. E. 1050 to S. A. E. 1095
is desirable, of course suitably heat treated to
develop spring properties.

One very desirable method of manipulating the
toy is illustrated in Figures 3, 4, and 5. The ends
of the coil have been grasped in the hands (Fig-
ure 3) and the coil has been bent into an axial
semi-circle 21 having a lower end 22 and a higher
end 23, with the effective top of the solid pile
on the low end at 24 and the effective top of the

3

solid pile at the high end at 25, the intermediate coils between 24 and 25 being fanned out at 26.

The condition shown in Figure 3 may be assumed to be the end of a cycle of manipulation during which the hand carrying the coil end 23 has been moving up or the hand carrying the coil end 22 has been moving down, or both operations have been taking place.

Between the positions of Figures 3 and 4, the relative elevation of the end 22 with respect to the end 23 has increased, and turns of the coil have been transferred from the solid pile 24 to the solid pile 25 in a very entertaining manner, while retaining the fan-like intermediate coils 26.

Between the positions of Figures 4 and 5, a relative upward movement of the coil end 22 with respect to the coil end 23 has continued, with resultant decrease in the solid pile 24 and increase in the solid pile 25, while turns are amusingly transferred across the fan-like portion 26.

The next step after that shown in Figure 5 will be relative elevation of the coil end 23 with respect to the coil end 22, causing a reverse transfer of turns from the solid pile 25 to the solid pile 24 to reach the condition shown in Figure 3. Thus by successively elevating one hand or the other, the turns of the coil move back and forth across the fan portion 26 and successively build up at one or the other end of the coil, with production of very interesting and attractive effects. The effect may be accentuated by the turns in solid color or variegated designs.

This oscillating action described in connection with Figures 3, 4 and 5 can be transferred to a walking motion by the use of an amusement platform such as an inclined plane or set of steps.

As shown in Figure 6 the coil bent in an axial semi-circle at 27 rests upon an amusement platform 28 having the character of an inclined plane, with a starting portion at 29 and successive landing portions at 30 and 31. The solid pile 32 at the rearward or high end is transferring to the solid pile 33 at the forward or low end across the fan-like intermediate portion 34. When the end of the solid pile 32 is reached, the last turn of the pile and the turns of the fan-like portion 34 will themselves be transferred across to the position 30. The energy stored in the system however will next carry the top-most turns over to the next landing portion 31, building up a solid pile 35.

Assuming a proper incline is used, this action will continue until the end of the amusement platform is reached.

The start of the operation in Figure 6 may be accomplished either by knocking over the top of the pile down hill, or actually bending the coil into an axial semi-circle with the lower end placed against a lower landing place.

In order to accomplish the walking action described in connection with Figure 6, the amusement platform may be a set of steps 36 as shown in Figure 7, having a starting portion 29' and successive landing portions 30' and 31', the solid pile at 32' on the starting portion moving through the fan-like intermediate turns 34' to the solid pile 33' at the landing portion 30', and then, when the coil has built up at 33', walking to the solid pile 35' at the next landing portion 31', and so on down the remainder of the steps.

In Figures 6 and 7, the amusement platforms 28 and 36 are necessarily limited in extent, and the device will stop when it reaches the end of the platform.

4

It is possible to use a continuous amusement platform as shown in Figures 8 and 9.

In Figure 8, an inclined plane 28' consists of a belt 39 extending over tension pulleys 40 and 41 suitably driven uphill as by providing an electric motor 42 (suitably of variable speed type) on the shaft of pulley 40. The spring toy 43 will then endlessly walk down the inclined plane as long as the device is driven at a speed which synchronizes with the walking speed of the spring. From this standpoint, therefore, it is desirable that the motor 42 be a variable speed motor (as provided by rheostat 42') to adjust the speed of upward movement of the platform.

A similar result can be accomplished by the use of an eccentric platform 44 as shown in Figure 9, the platform being circular and angularly disposed on the desirably vertical shaft 45 of a motor 46 supported on a suitable base. The edge of the platform 44 is suitably raised at 47, or an edge rim is provided around the entire circular perimeter of the platform, to prevent the spring toy from jumping off. The platform in Figure 9 can be rotated at any desired speed, as controlled by the rheostat 46'; and though it is best to have it synchronized with the walking speed, if there is lack of synchronism, the device will hop. One amusing way to use the device is to permit the operator to control the desired character of walk or hop by the speed. The general course followed by the device in walking in Figure 9 is around the circumferential edge or over a portion of the arc of the circumferential edge.

Based upon my experience with the device, and theoretical considerations, I am able to set forth certain theories of operation, but in doing this it is not desired to limit to this identical operation or predicate the disclosure upon the validity of the theory.

The property of the coil in transferring turns from a solid pile at the high end to a solid pile at the low end of a coil bent in an axial semi-circle, whether held in the hands or resting on an amusement platform having lower landing areas, is due to the gravitational force imparted to the coil. In the case of walking, once the toy is started, during the downward movement of the coil sufficient momentum is gained to carry the toy through the next cycle. Of course, to start the action, the necessary energy must be applied by an outside force such as the hand. This force must overcome the resisting torque which the material of the spring has when bending the coil axis through 180° arc.

As set forth below based upon experience and theoretical limitations, there are certain dimensional ranges which are important in permitting the device to operate. The theory given, while believed to be correct, is not essential to my invention.

To illustrate the action, it should be assumed that the spring in Figure 7 has initially been standing at 29' on the first step, and the upper end has been bent downward and placed in contact with the second step at 30', making the intermediate portion of the spring assume the curved contour 34'. In this deflected condition, the downwardly moving coils will follow a circular course, producing a centrifugal force which tends to carry the moving coils radially outward with respect to the center of the circle of motion. The value of this centrifugal force will depend upon the weight or mass of the moving coils and the velocity of the motion. The velocity in turn is determined by the force with which the spring

5

tends to reduce its deflection, or, in other words, by the stiffness of the spring.

A very stiff spring will create rapid motion, throwing the deflected end of the spring abruptly outward and transmitting such motion over the stiff coils to the stationary pile 33', thus tending to upset the spring.

When the stiffness of the spring is small as compared to its weight, the deflected end will move as indicated, tending to restore its balanced position by transferring the deflected coils along the curved center line of the spring, thus producing motion along a circular path 34', and thereby creating centrifugal force which tends to throw the moving end coils, after they leave the step 29', over to the opposite side as shown at 48, thus tending to start the next step in the walk of the spring. A position will be reached where the tension of the coils and the initial forces are balanced. If, in this position, the weight of the end coils is greater than the strength of the spring, the end will follow this excess force or weight and move downward until it reaches the next lower step at 31', at which the cycle will be repeated.

This walking process will stop if insufficient force has been applied. The force in the first step is the initial force plus the force of gravity and in the succeeding steps is the force of gravity. It has been found as a practical matter that an incline of from 2 to 4 inches per foot is optimum in the case of an inclined plane as shown in Figure 6. If the slope is not about 2 inches per foot, the gravitational force will hardly be enough to keep the coil walking. The limiting factor on the steepness of the slope is the tendency of the base of the coil to slide rather than walk. This limiting factor is not met in steps as shown in Figure 7, but in the case of inclined surfaces it has been found that about 30° inclination to the horizontal is the limit when reliance is placed upon the friction of steel against wood to prevent sliding. The surface of the inclined plane will function best when it is not slippery, and it is often desirable to provide the amusement platform with an anti-slip surface such as fabric at 28.

In order to make the spring walk, therefore, it is necessary to keep the ratio of stiffness to weight below a certain limiting value. This ratio of stiffness to weight or mass also determines the natural frequency of the spring, which is the criterion for the velocity of the walk of the spring. The natural frequency of an oscillating system in its basic form is expressed by the formula

$$f = C \sqrt{\frac{k}{m}}$$

wherein

k =stiffness

m =mass of the system

C =constant

I find it to be important to design the spring for a low natural frequency between the limits of 10 and 100 cycles per minute, the spring also having substantially no compression or tension between turns in closed position when no external force is acting, and having dimensions and proportions which permit manual handling.

For a helical spring of a given material, given number of turns and given outside diameter, the torsional strength of the cross section of the spring wire will determine the stiffness of the

6

spring. Stiffness in this connection may be defined as the force which creates a given deflection of the spring. For the same cross sectional area (and also for the same amount of material and therefore the same weight), a circular cross section will give the greatest stiffness while a thin rectangular cross section with its long side directed radially will give the smallest.

The rectangular cross section also has the further distinct advantage that the spring stacks and unstacks readily and without interfering of turns with one another.

Mathematical comparisons of the values of torsional strength may be obtained by computing the angular deflections of rods of unit length and unit cross sectional area, loaded by a unit torque, but differing in the shape of the cross section.

The above calculations have been carried out for a rod of circular cross section, a rod of square cross section and a rod of rectangular cross section with a ratio of the sides of 1 to 4, and the long and short sides disposed in the manner of the present invention, all having the same cross sectional areas. The deflection of the rectangular rod is 9.25 times as great as the deflection of the round rod and 8 times as great as the deflection of the square rod. In other words, the torsional stiffness of the round rod is more than 9 times as great as that of the rectangular rod and the torsional stiffness of the square rod is more than 8 times as great as that of the rectangular rod.

In making the above calculations it is convenient to use the formulas found in Timoshenko, Strength of Materials (1940), pages 264 and 270. For a circular cross section the angular deflection is:

$$\theta_0 = \frac{T}{GI_p}$$

wherein

T =torque

G =modulus of the material for shear

I_p =polar moment of inertia for a circular section

$I_p = 0.098 \times D^4$

where D =diameter of the circle. For a circle having an area of one square inch, the value of θ_0 is 1.13.

For a square or rectangular cross section the deflection is:

$$\theta = \frac{T}{\beta bc^3 G}$$

wherein

b =the long side of the rectangle

c =the short side of the rectangle, or the dimension in the direction of the force.

β =factor depending on the ratio of the sides of the rectangle.

For a ratio

$$\frac{b}{c} = 1, \beta = 0.141$$

and for a ratio

$$\frac{b}{c} = 4, \beta = 0.281$$

Substituting these values and computing the ratios of the deflections of the circular and square cross sections to the rectangular cross section, the values above mentioned are found.

The rectangular cross section also has a decided advantage in assuring proper stacking and unstacking of the turns without interference be-

tween turns, which of course would impede the walking action. In the case of a circular cross section the difficulty in obtaining proper stacking of the turns would of course be particularly serious.

From the above considerations, it will be evident that the rectangular cross section with the long side extending in the radial direction is of great advantage.

It has been found that to permit the invention to operate practically, the cross sectional dimension in a radial direction (Width 17, Figure 2) must be not less than 1.1 and not more than 10 times the cross-sectional dimension in an axial dimension (thickness 18, Figure 2) the preferable value being between two and five times and the most desirable value being about four times. This may be achieved by a rectangular section as shown Figure 2, in which the radial dimension or width of the section 17 is between 1.1 and 10 times the axial dimension or thickness of the section 18. The same result can be achieved by an oval or distorted oval section as shown in Figure 2a (made for example by flattening a wire), in which the major axis dimension of the oval 17' is radial of the coil and the minor axis dimension of the oval 18' is axial of the coil.

It has also been found that for practical operation of the device the outside diameter of the coil should be between 4 and 100 times the radial dimension of the coil section, the preferable value being between 10 and 50 times and the most desirable value about 30 times.

Limitations should also be imposed on length in order that the fan-like portion of the coil can spread over the semi-circular axial arc without causing permanent deformation, or without making it impossible to hold the turns in position in the absence of external force, or at the other extreme without falling side-ways and losing control. I find that the range of solid height of the spring should be between 1/2 and 5 times the outside diameter for practical operation, the preferable range being between 3/4 and one and one-half times and the most desirable value being substantially equal to the outside diameter.

With the dimensional ranges set forth, the coil will have adequate turns to bridge the axial semi-circle without external force being applied, and will be capable of bending 90° of arc under its own weight when the solid pile is reduced to half the coil.

Without attempting to limit to particular dimensions but in the interest of informing the public of a desirable set of dimensions, by way of example, the following values are given

	Inches
Axial dimension of coil cross section.....	0.025
Radial dimension of coil cross section.....	0.100
Outside diameter of coil.....	3
Solid height of coil.....	3

In view of my invention and disclosure variations and modifications to meet individual whim or particular need will doubtless become evident to others skilled in the art, to obtain all or part of the benefits of my invention without copying the structure shown, and I therefore, claim all such insofar as they fall within the reasonable spirit and scope of my claims.

Having thus described my invention what I claim as new and desire to secure by Letters Patent is:

1. A toy consisting of a helical spring of natural frequency between 10 and 100 cycles per minute, adapted to walk and oscillate, in which the lateral

force between turns is substantially zero in closed position when no external force is acting, and in the position of rest each coil contacts an adjacent one.

2. A helical spring toy adapted to walk and oscillate, consisting essentially of a helical spring having substantially no lateral force between turns in closed position when no external force is acting, in which in the position of rest each coil contacts an adjacent one, and in which the spring cross section is of a shape which has essentially lower torsional stiffness for a given cross sectional area than a square, thus producing a low natural frequency.

3. A toy consisting of a helical spring in which the force between turns is substantially zero in closed position when no external force is operating, in which in the position of rest each coil contacts an adjacent one, in which the spring cross section is of a shape which has essentially lower torsional stiffness for a given cross sectional area than a square, which when bent in the hands transfers turns bodily from a high end to a low end, and when started by a user on a suitable surface walks end over end down hill.

4. A toy comprising a helical spring adapted to walk and oscillate, in which the compression and tension between turns are substantially zero in closed position when no external force is acting, the radial cross sectional dimension is between 1.1 and 10 times the axial cross sectional dimension, the outside diameter is between 4 and 100 times the radial cross sectional dimension, the solid height is between one-half and 5 times the diameter, and the coil is capable of bridging an axial semi-circle without external force to hold it in position.

5. A helical spring toy adapted to walk and oscillate, consisting essentially of a spring having substantially no compression or tension between turns in closed position when no external force is acting, in which the spring radial cross sectional dimension is between 2 and 6 times the axial cross sectional dimension, the spring outside diameter is between 10 and 50 times the radial cross sectional dimension, the solid height is between 3/4 and one and one-half times the diameter and the coil bridges an axial semi-circle without external force holding it in place.

6. A helical spring toy adapted to walk and oscillate, consisting essentially of a spring having substantially no compression or tension between turns in closed position when no external force is acting, having a radial cross sectional dimension approximately 4 times the axial cross sectional dimension of the coil material, having an outside diameter approximately 30 times the radial cross sectional dimension, having a solid height approximately equal to the outside diameter and bridging an axial semi-circle without external force holding it in place.

7. An amusement device comprising an amusement platform having an upper starting portion and a plurality of landing portions, in combination with a helical spring bent in an axial semi-circle having its forwardmost turn resting on a landing portion and its rearwardmost turn resting on a starting portion, the spring having dimensions and energy relations which permit it to walk from the starting portion to the next landing portion and on to successive landing portions without application of force beyond an initial starting force and the action of gravity.

8. An amusement device comprising an amusement platform in the form of an inclined plane

having an upper starting portion and a plurality of lower landing portions, in combination with a helical spring toy of natural frequency between 10 and 100 cycles per minute, in which the force between turns is substantially zero in closed position when no external force is acting, and which walks end over end down the inclined plane.

9. An amusement device comprising an amusement platform having an anti-slip surface and in the form of an inclined plane having an upper starting portion and a plurality of lower landing portions, in combination with a helical spring of natural frequency between 10 and 100 cycles per minute, in which the force between turns in closed position is substantially zero when no external force is acting, and which walks end over end down the inclined plane.

10. An amusement device consisting of an amusement platform having a higher starting portion and a plurality of successively lower landing portions, in combination with a toy of helical spring form having substantially no compression or tension between turns in closed position when no external force is acting, having a radial cross sectional dimension between 1.1 and 10 times the axial cross sectional dimension, having an outside diameter between 4 and 100 times the radial cross sectional dimension and having a solid height between $\frac{1}{2}$ and 5 times the outside diameter, the spring bent in an axial semi-circle extending from the starting portion to the next landing portion on the amusement platform, and capable of walking to the next landing portion in successive end-over-end steps without further application of external force beyond the starting force and the action of gravity.

11. A helical spring toy having its turns of cross sectional dimensions which are substantially longer in the radial than in the axial dimension, curved in generally axially semi-circular form with one end higher than the other and having the property of transferring turns bodily from the high side to the low side as the elevation of the successive sides changes.

12. A helical spring toy having substantially no compression or tension between turns in closed position when no external force is acting, the radial dimension of the coil section being between 1.1 and ten times the axial dimension, the outside diameter of the coil being between 4 and 100 times the radial dimension of the coil section and the solid height being between $\frac{1}{2}$ and 5 times the diameter, the coil being adapted when bent in an axial semi-circle to transfer turns bodily from one end to the other by mere raising and lowering the elevations of the respective ends.

13. An amusement device comprising an endless amusement platform having an upper starting portion and a plurality of landing portions, and means for continuously driving the amusement platform, in combination with a helical spring bent in an axial semi-circle having its forwardmost turn resting on a landing portion and its rearwardmost turn resting on a starting portion, the spring having dimensions and energy relations which permit it to walk from the starting portion to the next landing portion and on to successive landing portions without application of force beyond an initial starting force and the action of gravity.

14. An amusement device consisting of an endless amusement platform having a higher

starting portion and a plurality of successively lower landing portions, and means for driving the amusement platform, in combination with a toy of helical spring form having substantially no compression or tension between turns in closed position when no external force is acting, having a radial cross sectional dimension between 1.1 and 10 times the axial cross sectional dimension, having an outside diameter between 4 and 100 times the radial cross sectional dimension and having a solid height between $\frac{1}{2}$ and 5 times the outside diameter, the spring bent in an axial semi-circle extending from the starting portion to the next landing portion on the amusement platform, and capable of walking to the next landing portion in successive end-over-end steps without further application of external force beyond the starting force and the action of gravity.

15. An amusement device comprising an amusement platform in the form of an inclined plane having an upper starting portion and a plurality of lower landing portions, variable speed means for driving the inclined plane uphill in synchronism with the walking of a helical spring, in combination with a helical spring bent in an axial semi-circle having its forwardmost turn resting on a landing portion and its rearwardmost turn resting on a starting portion, the spring having dimensions and energy relations which permit it to walk from the starting portion to the next landing portion and on to successive landing portions without application of force beyond an initial starting force and the action of gravity.

16. An amusement device comprising an amusement platform of circular form inclined to the horizontal and having a confining edge, and means for whirling the platform, in combination with a helical spring bent in an axial semi-circle having its forwardmost turn resting on a landing portion and its rearwardmost turn resting on a starting portion, the spring having dimensions and energy relations which permit it to walk from the starting portion to the next landing portion and on to successive landing portions without application of force beyond an initial starting force and the action of gravity.

17. An amusement device comprising an amusement platform having an endless succession of upper starting portions and lower landing portions, means for driving the amusement platform, means for controlling the speed of the platform to harmonize with the walking speed of a helical spring, in combination with a toy of helical spring form having substantially no compression or tension between turns in closed position when no external force is acting, having a radial sectional dimension between 1.1 and 10 times the axial sectional dimension, having an outside diameter between 4 and 100 times the radial cross sectional dimension and having a solid height between $\frac{1}{2}$ and 5 times the outside diameter, the spring bent in an axial semi-circle extending from the starting portion to the next landing portion on the amusement platform, and capable of walking to the next landing portion in successive end-over-steps without further application of external force beyond the starting force and the action of gravity.

18. The method of operating an amusement device comprising a helical spring having substantially no compression or tension between turns in closed position when no external force

11

is acting, and having a radial cross sectional dimension of between 1.1 and 10 times the axial dimension of the coil section, having an outside diameter of coil between 4 and 100 times the radial dimension of the coil section, and having a solid height between $\frac{1}{2}$ and 5 times the diameter, which comprises bending the coil into an axial semi-circle and alternately raising and lowering the respective ends of the coil to transfer turns bodily from one end to the other for the amusement of an observer.

19. The method of operating an amusement device comprising a helical spring having substantially no compression or tension between

12

turns when no external force is acting, and having a radial cross sectional dimension of between 1.1 and 10 times the axial dimension of the coil section, having an outside diameter of coil between 4 and 100 times the radial dimension of the coil section, and having a solid height between $\frac{1}{2}$ and 5 times the diameter, which comprises bending the coil into an axial semi-circle with the forward end of the coil arriving at one of a plurality of successive lower landing places to which the coil walks end-over-end without further application of external force other than gravity.

RICHARD T. JAMES.