

Nov. 3, 1942.

F. J. FETTE

2,300,663

HEAT EXCHANGE DEVICE

Filed Oct. 20, 1939

2 Sheets-Sheet 1

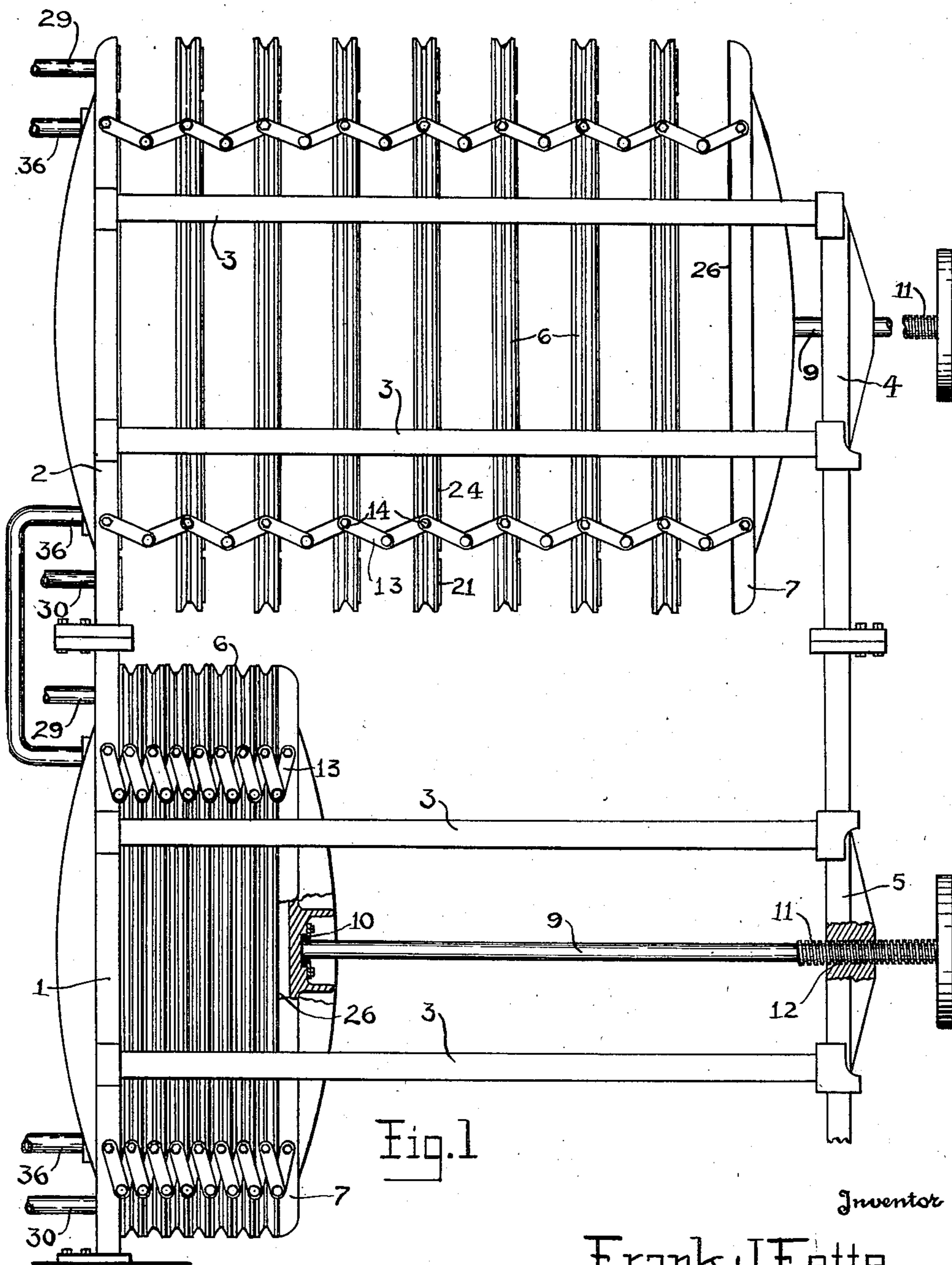

Inventor

Frank J. Fette

By

Arthur Minnick

Attorney

Nov. 3, 1942.

F. J. FETTE

2,300,663

HEAT EXCHANGE DEVICE

Filed Oct. 20, 1939

2 Sheets-Sheet 2

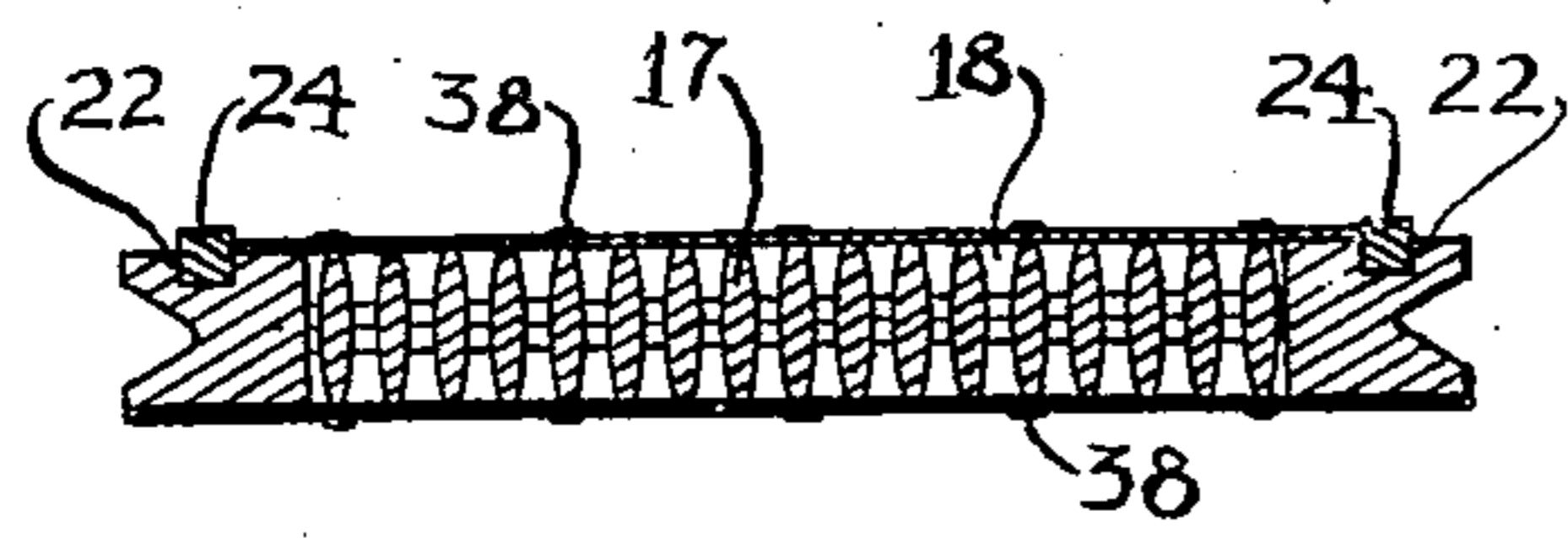
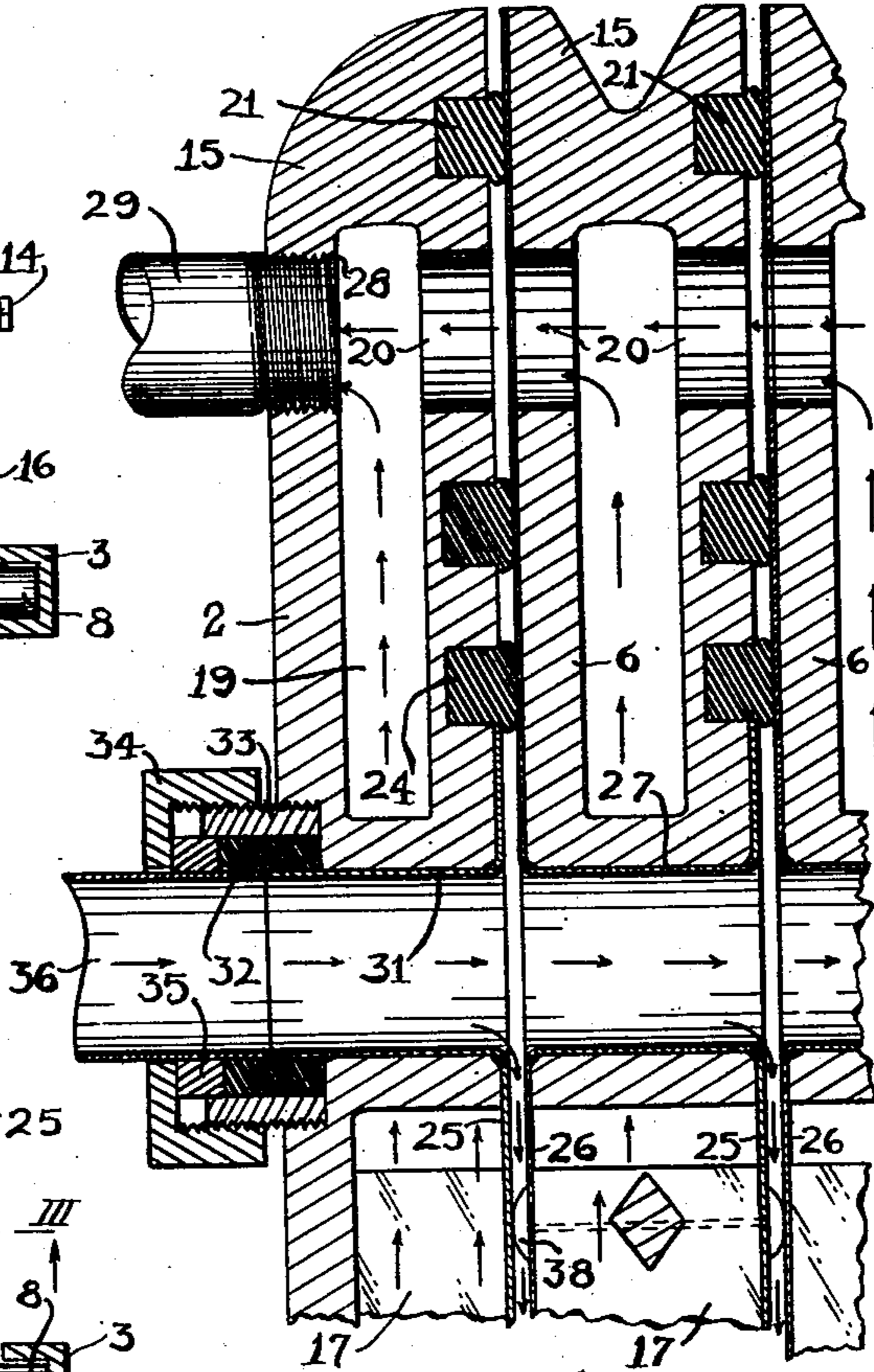
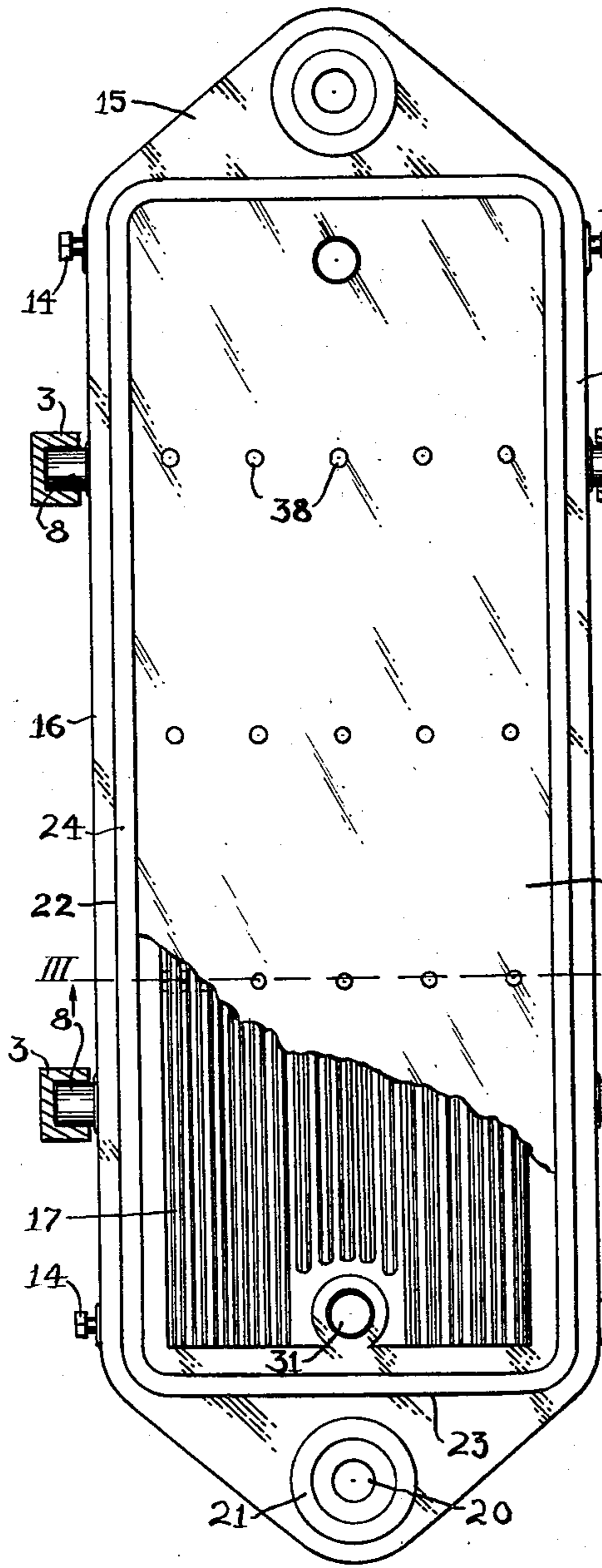

Fig. 3

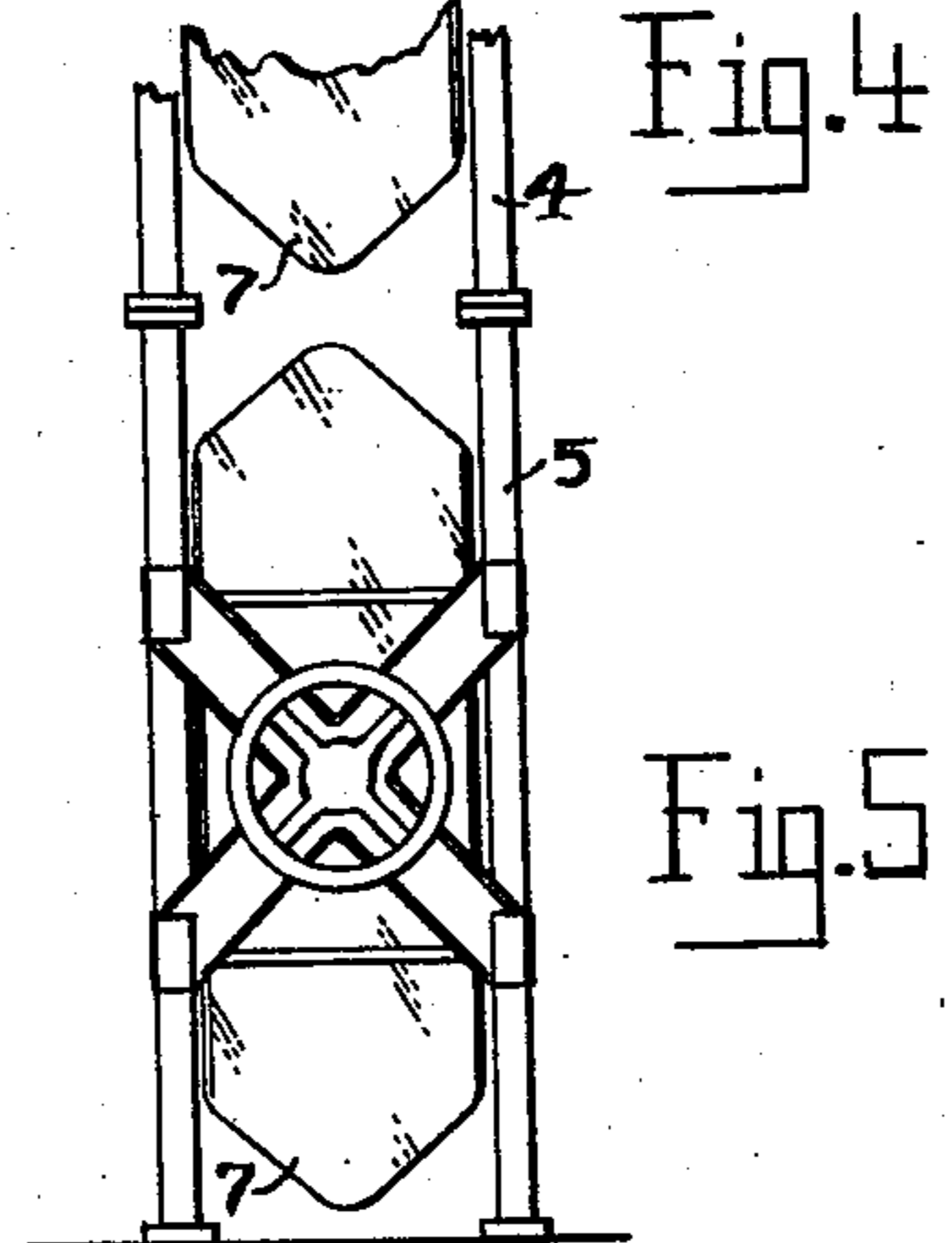

Fig. 4

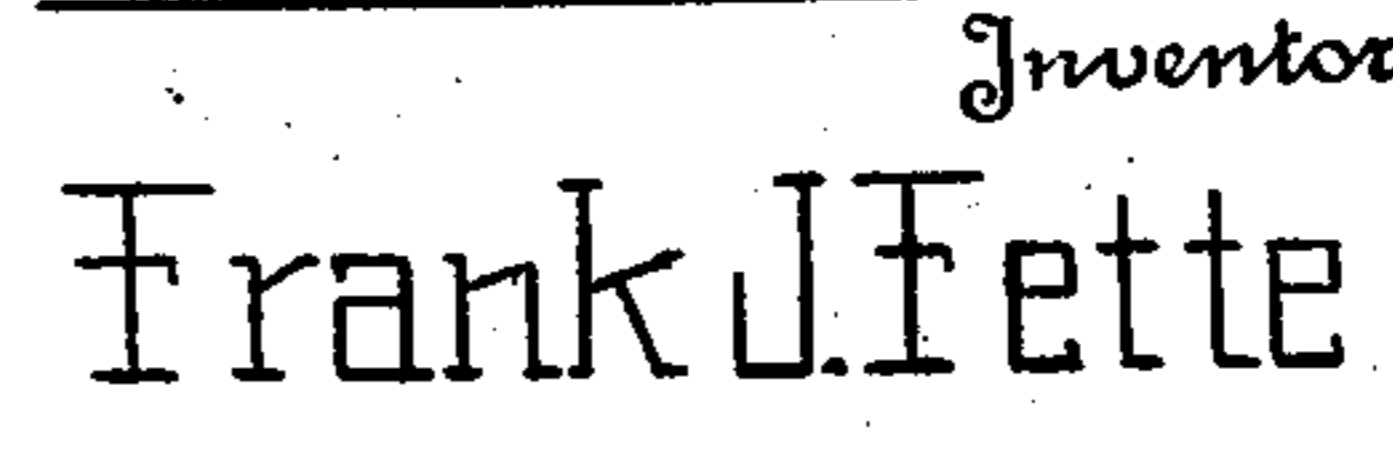

Fig. 5

Inventor  
Frank J. Fette

By  
Arthur Mimmick  
Attorney

# UNITED STATES PATENT OFFICE

2,300,663

## HEAT EXCHANGE DEVICE

Frank J. Fette, Tampa, Fla.

Application October 20, 1939, Serial No. 300,352

3 Claims. (Cl. 257—245)

This invention relates to devices for transferring heat from one fluid to another. It has for its primary object the provision of means by which the fluid to be treated may flow in thin flat streams between thin, smooth, sheet metal plates of stainless steel or other non-corrodible material, the plates being supported in a manner to prevent either too close approach or too great separation. A further object of the invention is to provide means by which a plurality of units may be drawn apart for ready and efficient cleansing and may be forced and held together in operative relation, while being supported and guided in their movement toward proper assembly. Another important object of the invention is to provide efficient gaskets to retain the fluids, the mounting of the gaskets being such that the spaces between the metal plates will not be dependent solely upon the thickness of the gaskets. A still further object of the invention is to provide a large surface of contact between the heating or cooling liquid and the metal by which the heat is conducted toward or from the liquid under treatment.

The device is especially adapted for pasteurizing milk or beer without danger of overheating while insuring uniformity of action throughout the liquid and it is also highly efficient in the subsequent cooling or chilling of the liquid.

My previous Patent No. 2,165,094, July 4, 1939, discloses sheet metal units of lighter construction arranged for pasteurization, cooling, and chilling in successive operations with automatic means for maintaining desired temperatures, and it will be understood that the present device, while of heavier construction and intended for a greater capacity, may be used in the same manner and with the same controls as suggested in the patent.

In the drawings, Figure 1 is a side elevation showing a preferred embodiment of the invention, the units of the upper group being separated, as for cleaning, and the units of the lower group being assembled in closed position ready for use; Fig. 2 is a front elevation of one of the intermediate units, having a portion of the sheet metal surface broken away; Fig. 3 is a cross section taken on the line III—III of Fig. 2; Fig. 4 is a fragmentary sectional view through the center of the upper end portions of an end unit and of two of the intermediate units; and Fig. 5 is a fragmentary end elevation of the structure of Fig. 1 on a smaller scale.

It will be understood that the details of construction, the proportions, the number of units,

and the mode of arrangement of the parts are intended to be for purposes of illustration and not as limiting the scope of the invention.

In Fig. 1, an inner end unit 1 has mounted thereon an upper end unit 2. On each side of each of these units, are secured the ends of channel members 3, which, at their other ends, are secured to and supported by end frames 4 and 5. The intermediate units 6 and the outer end units 7 have supporting rollers 8 journaled on studs upon opposite sides of the units, these rollers extending into channels in the members 3 which serve as tracks or runways for the rollers. A rod 9 for each of the outer end members 7 has its front end swivelled centrally of the member as by a detachable plate 10, and at its rear end, is screw-threaded at 11 to engage a threaded socket 12 in an end frame 4 or 5, the length of the threaded portion of the rod being such that it may engage within the socket before any great amount of pressure is required to bring the units 6 and 7 together and against the end units 1 or 2, in the closed position shown in the lower portion of Fig. 1.

The unthreaded front portion of the rod 9 being smaller in diameter than the threaded portion will slide freely through the socket 12 after the threaded portion has been unscrewed out of the socket. Each of the intermediate units 6 is connected by a jointed or flexible connection 13 to the adjacent units on each side and as the rod 9 is pulled backward, the units 6 and 7 will separate from each other successively, the pull exerted on each unit being transmitted through the connections 13 to the next units in order until all are pulled apart. In the upper portion of Fig. 1, the units are shown as separated by sufficient distances to allow easy cleaning of both surfaces of the units. If a greater space is desired, the connections 13 may be detached from the studs 14 by which they are attached to the units to permit any or all of the units to be slid in either direction along their supporting runways 3 until they are as far apart as may be deemed necessary.

The present units comprise a body portion which will preferably be cast from aluminum or other metal or alloy having a high thermal conductivity, this body portion being formed with a plurality of longitudinal passages or channels having a large surface for contact with a liquid flowing through the channels. In Figs. 2, 3, and 4, the cast metal body is shown as having top and bottom end portions 15 connected by side bars 16, the central portion of the body having a plu-

rality of intermediate web members 17 spaced to provide channels 18, which communicate with the channels 19 formed within the end portions 15. Near each end of the body portions 15 are passages 20 communicating with the channels 19 and surrounding these passages 20 are annular recesses formed within one outer surface of each end portion for the reception of gaskets 21. At a little distance inward from the side edges of the same surface of the body of each unit are longitudinal recesses 22 formed in the side bars 16, these recesses being connected, preferably by a curved recess at each corner, with transverse recesses 23 which cross the surface of the body between the annular gaskets 21 in the two end portions 15. A continuous gasket 24 set within the recesses 22 and 23 thus surrounds the entire central portion of the body.

The surface of the body, including the outer edges of the webs 17, within the gasket 24, will be machined smooth for the reception of a sheet metal plate 25 which will be brazed, soldered, or welded upon the smooth surface of the body. This plate 25 will be of some suitable corrosion-resistant material such as Monel metal or stainless steel, and its edges will lie in contact with the gasket 24. In the intermediate units, only one surface will have the gasket 24, the other surface being smooth over its entire extent to receive a plate 26 which may cover the entire surface but which will at least extend outward far enough to be engaged by the gaskets 21 and 24. In these intermediate units, the plates 25 and 26 are connected near each end of the units by tubes 27 secured to the plates by liquid-tight joints. The fixed end units 1 and 2 are provided with ports 28 communicating with the channels 19 in the top and bottom end portions 15, these ports being preferably threaded to receive the ends of pipes 29 and 30 through which hot or cold liquids may enter and leave the channels within the cast metal body portions of the units. The inner end units 1 and 2 near the top and bottom of the spaces within the gaskets 24, will be provided with outwardly extending tubes 31 secured to the plates 25 and having their outer ends within rubber tubes 32 in threaded fittings 33 which have threaded caps 34 bearing upon glands 35 which act to compress the tubes 32 upon the adjacent ends of tubes 31 and tubes 36 which serve as inlet and outlet ports for liquids which are to be heated or cooled by the liquids which flow through the channels within the bodies of the units.

It will be seen that as the units are brought closely together, the gaskets 21 and 24 of each of the units 1, 2, and 6 will come into contact with a sheet metal surface of a plate 26 of an adjacent unit. The movable outer end units 7 will have a surface plate 26 to engage the gaskets on the adjacent unit 6, and it will have inlet and outlet passages 20 and channels 18 and 19 within the cast body portion, but the plate 26 will have no tubes 27 therein.

When the units have been forced closely together by the action of the screw 11, the gaskets 21 will be compressed to form liquid-tight seals around the ports 20 and the gaskets 24 will be similarly compressed to form tight seals around the edges of the plates 25, the gaskets slightly overlapping the edges, thus forming broad but thin passages between the plates 25 and 26. The thickness of these passages may be definitely limited by the use of rivets 38 which pass through web members 17 and serve not only as securing means to assist in holding the plates upon the

webs but the heads of the rivets also provide a plurality of knobs over the surface of the plate to prevent too close approach of one plate to another. As shown in Fig. 2, these rivet heads may be arranged in spaced rows, the rows being at such distances from the ends that when the units are alternately reversed in assembling, the heads of the rivets of one row will engage the adjacent plate midway between the rows of heads on that plate. It will be seen that the plates will be rigidly held from buckling, so that differences of pressure of the liquids on either side of the plates cannot cause an increase or decrease in the space between them.

The liquid to be treated flows between smooth, non-corrosive surfaces in a thin, broad sheet so that no part of the liquid stream can be far from a surface, and the transfer of heat between the two liquids will be limited only by the rate of conductivity of the metals used and by the temperatures of the two liquids.

While only two groups of plates have been illustrated, it will be evident that as many groups will be used in any instance as are needed for the kind of operation or sequence of operations to be performed. The prior patent referred to shows three groups and additional plates or groups of units and additional operations may be added as desired.

It has not been deemed necessary to illustrate herein such pumps and temperature controls as are indicated in the prior patent, or to illustrate any of the various circulations or recirculations of the heat exchange liquids whereby heat taken up by such liquid in one group of units may be used to warm an incoming cold liquid in another group, and so on, since such regeneration is well known to those familiar with the art.

Many modifications and changes in the specific constructions illustrated may be made without departure from what is claimed.

I claim:

1. A heat exchange unit for use as one of a series of identical units and comprising a framework having a plurality of communicating cavities within its interior and having two substantially parallel flat walls separated by said cavities, each of these walls having a central open portion, one of said walls having a continuous recess surrounding the central open portion, a gasket in said recess projecting outward therefrom, a sheet metal plate secured to the outer surface of the framework with its edges closely adjacent to the inner periphery of the gasket recess, the said framework having ports therein through the parallel walls on both surfaces to communicate with the cavities at the opposite ends thereof and outside of the space defined by the gasket surrounding the central portion, a continuous recess surrounding one of the ports being formed in the surface of the wall at each end of the framework, a gasket in each recess, a sheet metal plate upon the opposite surface of the framework from the gaskets and having a greater area than the space surrounded by the gasket whereby to form a means for contact with a corresponding gasket on an adjacent unit of an assembly, means constituting a passage for liquid opening to the remoter faces of the metal plates on opposite surfaces and forming a liquid-tight connection therebetween, a plurality of webs of high thermal conductivity within the cavity between the plates and in heat-exchange contact therewith along the edges of the webs, said webs and plates forming a plurality of channels for a

liquid, the ports in the walls constituting inlet and outlet passages for the heat-exchange liquid communicating with the channels.

2. A heat exchange unit for use as one of two end members for a series of intermediate units and comprising a framework provided with an interior cavity forming a flow space for a heat-exchange fluid, the framework having inlet and outlet ports formed in the walls thereof communicating with the said cavity, the framework also having a flat wall having a continuous recess surrounding an open central portion, a gasket in said recess, a sheet metal plate secured to the framework with its edges closely adjacent to the inner periphery of the gasket and means constituting a passage for liquid to be treated open-

ing to the surface of the sheet metal plate remote from the framework and forming a liquid-tight connection therewith.

3. A heat exchange apparatus for the exchange of heat between two streams of fluids, comprising a series of identical intermediate units as defined in claim 1, end units at each end of the series and means for clamping together the end units and the intermediate units, whereby to compress the gaskets of each unit against an adjacent smooth sheet metal surface to form liquid tight thin flow passages for one liquid between the confronting surfaces of adjacent plates and passages for the heat exchange fluid communicating with the spaces between the webs.

FRANK J. FETTE.