

Jan. 6, 1942.

L. C. KARRICK

2,268,989

PROCESS FOR IMPROVING FUEL

Filed April 17, 1936

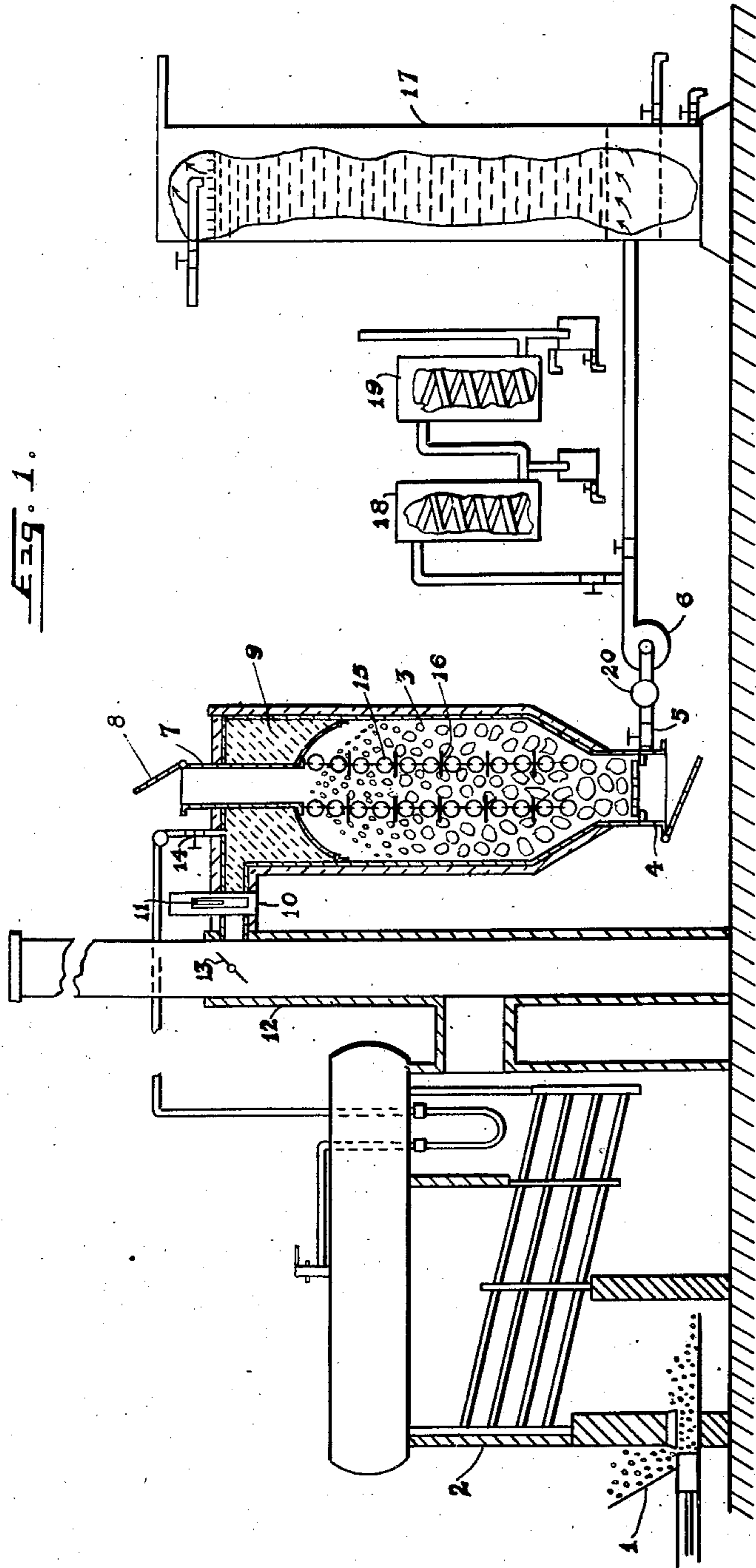

FIG. 1.

Inventor

Lewis C. Karrick

By

P. M. Thomas

Attorney

UNITED STATES PATENT OFFICE

2,268,989

PROCESS FOR IMPROVING FUEL

Lewis C. Karrick, Salt Lake City, Utah

Application April 17, 1936, Serial No. 74,835

10 Claims. (Cl. 202—15)

This invention relates to the low temperature carbonization of coals and other solid carbonaceous materials so that the coal will yield a reactive easily ignited form of solid smokeless lump fuel which is very well suited to burning in all types of household heating and cooking equipment, and also is excellently adapted to burning in charcoal braziers. The invention is especially adapted to the treatment of mixed sizes of coals which have been crushed to the sizes used in power plants, and thereby produce domestic fuel in the lump sizes that are found to be most popular in all domestic uses.

I have discovered a method for the treatment of dust-free graded sizes of coal, all being treated simultaneously in the same chamber or retort, while applying the thermochemical principles that cause the formation of a series of sizes of dense lumps of chemically reactive fuel, also coal oils that can be easily refined into high anti-knock gasoline and other oil products, and fuel gases of both high and low heating value. At the same time I make use of thermal principles that produce economies in cost of heating while carrying out the treatments, so that the fuel cost is low. A new heat-exchange step is used in the treatment by which I have found it unnecessary to construct and maintain costly steam superheaters, and yet I am able to use highly-heated superheated steam which enables this process to yield the afore-mentioned unusual products from coals. The process has been found to produce from Utah coals, or other partially-coking coals, large yields of low-heating value gases for industrial needs, and at the same time a less amount of gas with heating value as high as natural gas. Steam and electric power are produced simultaneously with the above treatment, by the heat cycles through which the combustion gases and steam, used in the processing, are routed. The apparatus required in this coal-treating process is simple to erect and its maintenance is low so that the manufacturing cost of the coal products will be low. Combustion of the new fuel gives a beautiful smokeless fire with long blue and amber colored flames.

I have discovered that certain types of coals used in my studies, especially the large bodies of eastern Utah coals on the Public Lands, reach a stage of partial plasticity at a temperature beginning below 365° C., at which oil vapors begin to form, and extending through the oil-yielding range of temperatures. These types of coals do not fuse as do the ordinary coking coals, nor do they disintegrate like sub-bituminous coal or

lignites. The tendency of the Utah coals to become weak structurally during this softening stage, and fall to pieces if not held together, is a unique property which is made use of in this process. I have found that the smaller lumps of coal will become soft to the center within this range of temperature but the largest lumps are not uniformly soft to the center for the reason that the change from the rigid coal stage into the rigid coke state is a gradual and progressive transition through the softened stage, and at no time, if the heating is rapid, is the temperature the same throughout the large lumps. Thus the large lump is always hard at its surface, part way in, or at the center, and it is desirable to heat it more slowly than the small lumps. Because the lumps of large size are stronger, and because they are advantageously heated slower, I place them at a position in the retorts where they are under greater pressure, also where they are more remote from the source of heat and thus become heated at a slower rate. These conditions are observed in treating the various sizes of lumps so that the smallest lumps are therefore placed at the top of the retort and nearest to the source of heat. This treatment causes by my process all of the lumps of coal, regardless of size, to become quite dense and hard while still observing the thermochemical conditions that produce reactive carbon with simultaneous evolution of high quality oil and gases. These points are more fully described in my U. S. Patent No. 2,011,054.

Since some of the above types of coals are more compressible than others, or they may vary somewhat from the same coal seam, it is found to be desirable to apply means of controlling the pressure throughout the mass of coal undergoing treatment. This is accomplished by interposing within the coal mass an unyielding member or members which is unaffected by the compressibility or compacting of the coal mass. Several forms of apparatus for accomplishing this step are fully described in my copending application for U. S. Patent, Serial No. 701,838, now Patent No. 2,165,143, and one form is shown in the accompanying drawing which forms a part of this application for patent.

I have found that it is very much better to treat the non-coking or partially-coking types of coals in large batches with a heat-carrying fluid passing between the lumps. This makes possible the speeding up of the distilling time over that which would be required if the coal were heated in ovens surrounded with combustion

gases or other heating mediums. By contacting the lumps with a suitable heat-carrying medium, the distilling time is reduced to the time required for any individual lump. I have found that suitable gases for carrying out this treatment of coal, are: combustion gases with a minimum of free oxygen, producer gas, water gas, and superheated steam, or a combination of these gases. I have accomplished the successful treating of coal with a combination of these gases in a simple manner, and important economies are obtained.

In carrying out this process the coal such as is normally delivered to power plant or industrial plants, say dust to 2-inch, is screened into a continuous series of sizes with minimum steps between screens. The dust to say $\frac{5}{8}$ -inch is sent to bunkers for use as heating-fuel for the process, and the remaining dust-free lumps are charged into a tall shaft retort chamber with the smallest lumps at the top and the largest lumps at the bottom of the charge. The coal in the chamber, consisting of a column of graduated lumps, is heated by passing hot gases downwardly through the chamber between the lumps. The temperature of the gases is kept below 1150° F. while carrying on the low temperature carbonization, but if producer gas or water gas is desired from the process then the temperature is increased and rapid gas generation will follow.

I have found that substantially neutral combustion gases may be used for the heat-carrying fluid provided their temperature is not excessively high. It is the top layer of coal only that would suffer by excessive gas temperature inasmuch as layers of coal lower down in the retort will receive their heat gradually as the rise in temperature of the superposed coal permits hotter and hotter gases to pass down through the charge. I provide means, however, for preventing overheating of the coal until after the oil-forming volatiles are removed, after which the combustion gases are increased in temperature in order that producer gas is formed from the top layers of small-sized lumps of coal.

I have also found that superheated steam is a very desirable heating medium for distilling the lumps of coal. This heat-carrying fluid has the advantage of any of the other gases mentioned in that there is no diluent gas mixed with the rich coal gases, and thus gas as rich as natural gas (900 to 1100 B. t. u. per cubic foot) may be obtained from treating Utah coals with this process. In this invention I provide means for obtaining superheated steam without the necessity of installing superheaters which are rather costly to install and to maintain.

This invention will be understood from the description in connection with the accompanying drawing. Figure 1 is a side elevation partly in section and partly broken away showing an illustrative embodiment of the invention. Crushed coal is screened into a series of closely spaced sizes by a screening plant not shown, the dust to say $\frac{5}{8}$ -inch size being subsequently fed into stoker hopper 1 from which it is burned under the boilers of steam plant 2. The sized dust-free coal lumps are deposited into bins provided for the different sizes, and from these bins the coal is deposited into retort 3 by means of chutes or charging larries, also not shown.

Retort 3 comprises a cylindrical steel wall surrounded with a thick layer of insulating material. The bottom is conical and connects with an outlet neck and door 4. Leading from the

side of neck 4 is pipe connection and valve 5 through which the gases and vapors are drawn by exhauster 6. The top of retort chamber 3 is of steel plate covered with insulation, and passing down through the top is loading pipe 7 provided with gas-tight door 8. This loading pipe extends about one third to one half the height of the retort. Within the top of the retort chamber is a built-in checker work of fire brick 9 which fills the space down to the lower extremity of the loading pipe 7. Leading out of one side of the top of the retort is conduit 10 and gate 11, leading into the side of the steam plant stack 12. A damper or gate 13 is provided in the stack just above the connection with the conduit 10. Also, leading into the top of the retort chamber is steam line and valve 14. At the bottom of loading pipe 7 is hung the coal-supporting members 15 which may be large link chain with lateral extension members 16. These extension members are so spaced that the lumps of coal which "arch" against these members limit the downward component of weight to a small portion of the actual weight of the coal column, also part of the weight of the coal is resolved into a horizontal stress. The supporting members 15 are placed near enough together throughout the coal charge that their space is not more than three times the average diameter of the contacting lumps of coal. This is a safe spacing but need not be adhered to, in fact some of our coals do not require more than occasional lateral supports.

Exhauster fan 6 delivers the gases and vapors into the base of gas-cooler 17, of the Doherty or other well known types, in which the water and oil condensates are collected and drawn off at the base and the fixed gases are drawn off at the top. Cooler 17 is used while combustion gases are being passed down through the coal, the resulting gases coming from the cooler being of low fuel value due to dilution with the combustion gases.

Exhauster fan 6 may also deliver the gases, oil and water vapors into fractionating condensers 18 and 19. Condenser 18 is maintained at a temperature above the condensing temperature of the water vapor. I have found that this procedure permits condensation of the oils that are heavier than water in condenser 18, and thereafter the balance of the oils and all of the water is condensed in condenser 19, thus permitting the oil and water to be separated by decantation.

A number, at least two, retorts may advantageously be operated simultaneously from the same heat sources, originating with the combustion gases of the steam plant and from the steam generated therein. To do this another connection is made to stack 12, like conduit 10, and leading into the top of another retort. Also, the same condensing and cooling system will serve both units, the exhauster 6 being connected through manifold 20 to the different retort outlets 5.

When the coal is charged into the retort as described above, gate 11 is opened, damper 13 is closed, gates 8 and 4 are closed, then exhauster 6 is started. The hot products of combustion from stack 12 are drawn into the retort and down through the coal charge via the checkerwork 9. As soon as the checkerwork reaches about 700° F. at its bottom the top layer of coal will begin to distil, and as the heating continues and the top temperature rises the heating zone moves downwardly through the coal while the

hot gases are continuously serving to preheat the lower layers of coal. I have found that when the coal has been distilled of its oil-yielding volatiles down to about the middle of the retort, the combustion gases from the steam plant may be shut off and diverted into another retort. Thereupon the steam valve 14 is opened, gate 11 having been closed, and the incoming steam passes through the highly heated checkerwork wherein the steam becomes superheated and then passes down through the hot semi-coke residue, thence through the coal and accomplishes further distillation. It will be recognized that the stored heat in the checkerwork and in the hot semi-coke residue are made use of for superheating steam and that this heat is again utilized to complete the distillation of the bottom part of the charge. This procedure makes it possible to dry the coal well with a small flow of combustion gases such that practically no distillation of the coal takes place. After the drying of the coal a larger flow of the combustion gases may be used to effect the distillation of the coal part way down the retort height. During this stage of the treatment I have found that it is desirable to use a small amount of excess air in order that some combustion of the top layers of semi-coke takes place, thereby heating the reacting carbon and carbon dioxide to a point at which the producer reaction takes place; this causes, thereby, the generation of producer gas instead of permitting the coal gases to be diluted with incombustible combustion gases. It should be noted that the producer gas is formed from the relatively low value semi-coke in the smallest pieces. When the top half, or thereabouts, is distilled by the heat of the stack gases, the superheated steam completes the distillation to the bottom of the charge. During this last stage the gases formed from the coal are free of any diluents of any kind and, from Utah coals, will have a fuel value of 1,000 B. t. u. per cubic foot or higher. The gases from the two stages of heating, that with the stack gases and that with the superheated steam, are of very different heating value and have their advantageous fields of uses. Therefore they should be stored in separate gas holders.

It should be noted further that during the last stage of distilling, with the superheated steam, that cooling or dry-quenching has been progressing as the top heat of the charge is being transferred into the bottom of the retort. Consequently when the charge is completely distilled the steam should be permitted to flow into the top of the retort until the entire body of semi-coke is cooled to 400° F. or less as at this temperature this reactive semi-coke will not take fire. Preferably, the steam used in the treatment is steam coming from an engine or other power generator, that is, bled steam that has already provided work energy.

I claim:

1. The process of preparing an improved fuel from Utah type coal comprising forming a column of lumps of said coal within a vertical retort, passing hot gases of combustion downwardly through said column to partially carbonize said lumps, discontinuing the flow of said hot gases of combustion and passing steam heated to a temperature below that of the said hot gases of combustion downwardly through said column to complete the carbonization of said lumps.

2. The process of preparing an improved fuel from Utah type coal comprising forming a col-

umn of lumps of said coal within a vertical retort, passing hot gases of combustion through a heat accumulator and thereafter passing said gases downwardly through said column to partially carbonize said lumps, discontinuing the flow of said gases and passing steam heated to a temperature below that of the said gases through said heat accumulator and thereafter passing said steam downwardly through said column to complete the carbonization of said lumps.

3. The process of preparing an improved fuel from Utah type coal comprising forming a column of lumps of said coal within a vertical retort, passing hot gases of combustion through a heat accumulator and thereafter passing said gases downwardly through said column to partially carbonize said lumps, discontinuing the flow of said gases and passing steam heated to a temperature below that of the said gases through said heat accumulator and thereafter passing said steam downwardly through said column to complete the carbonization of said lumps, said heat accumulator being brick checkerwork, whereby said heat accumulator is heated to a high temperature by said hot gases of combustion and said steam is superheated during passage through said heat accumulator.

4. The process of preparing an improved fuel from Utah type coal comprising forming a column of lumps of said coal within a vertical retort, said lumps being of graduated size within the column with lumps of progressively smaller size being positioned at progressively higher points within said retort, passing hot gases of combustion downwardly through said column to partially carbonize said lumps, discontinuing the flow of said hot gases of combustion and passing steam heated to a temperature below that of the said hot gases of combustion downwardly through said column to complete the carbonization of said lumps.

5. The process of preparing an improved fuel from Utah type coal comprising forming a column of lumps of said coal within a vertical retort, said lumps being of graduated size within the column with lumps of progressively smaller size being positioned at progressively higher points within said retort, passing hot gases of combustion through a heat accumulator and thereafter passing said gases downwardly through said column to partially carbonize said lumps, discontinuing the flow of said gases and passing steam heated to a temperature below that of the said gases through said heat accumulator and thereafter passing said steam downwardly through said column to complete the carbonization of said lumps.

6. The process of preparing an improved fuel from Utah type coal comprising forming a column of lumps of said coal within a vertical retort, said lumps being of graduated size within the column with lumps of progressively smaller size being positioned at progressively higher points within said retort, passing hot gases of combustion through a heat accumulator and thereafter passing said gases downwardly through said column to partially carbonize said lumps, discontinuing the flow of said gases and passing steam heated to a temperature below that of the said gases through said heat accumulator and thereafter passing said steam downwardly through said column to complete the carbonization of said lumps, said heat accumulator being brick checkerwork, whereby said heat accumu-

lator is heated to a high temperature by said hot gases of combustion and said steam is superheated during passage through said heat accumulator.

7. The process of preparing an improved fuel from Utah type coal comprising forming a body of lumps of said coal in graduated sizes within a retort, the size of the lumps being smallest at one end of said body and being progressively larger at points therein farther from said end, introducing hot gases of combustion into said end and passing said gases through said body to partially carbonize said lumps, discontinuing the flow of said gases and introducing steam heated to a temperature below that of said gases into said end and passing said steam through said body to complete the carbonization of the lumps.

8. The process of preparing an improved fuel from Utah type coal comprising forming a body of lumps of said coal in graduated sizes within a retort, the size of the lumps being smallest at one end of said body and being progressively larger at points therein farther from said end, passing hot gases of combustion through a heat accumulator, thereafter introducing said gases into said end and passing said gasses through said body to partially carbonize said lumps, discontinuing the flow of said gases, passing steam heated to a temperature below that of said gases through said heat accumulator, thereafter introducing said steam into said end and passing said steam through said body to complete the carbonization of said lumps.

9. The process of preparing an improved fuel from Utah type coal comprising forming a body of lumps of said coal in graduated sizes within a

retort, the size of the lumps being smallest at one end of said body and being progressively larger at points therein farther from said end, passing hot gases of combustion through a heat accumulator, thereafter introducing said gases into said end and passing said gases through said body to partially carbonize said lumps, discontinuing the flow of said gases, passing steam heated to a temperature below that of said gases through said heat accumulator; thereafter introducing said steam into said end and passing said steam through said body to complete the carbonization of said lumps, said heat accumulator being brick checkerwork, whereby said heat accumulator is heated to a high temperature by said hot gases of combustion and said steam is superheated during passage through said heat accumulator.

10. The process of forming improved fuel products by carbonizing graded sizes of Utah type coal, which comprises separating said coal into a series of sizes, with the dust removed, and the coal introduced into a vertical retort, with the largest lumps at the bottom, supporting said coal throughout its height and reducing its downward and internal pressure, passing hot combustion gases downwardly through the layers of coal in such a manner that said gases contact first the small lumps of coal and last the largest lumps to remove part of the volatile materials, discontinuing the hot combustion gases and introducing steam into said retort from the top end thereof, passing said steam down through the coal to complete the distillation thereof with the contained heat of the partly distilled coal.

LEWIS C. KARRICK.