

Dec. 23, 1941.

J. B. CLARK

2,267,079

SEPARABLE FASTENER

Filed Feb. 21, 1941

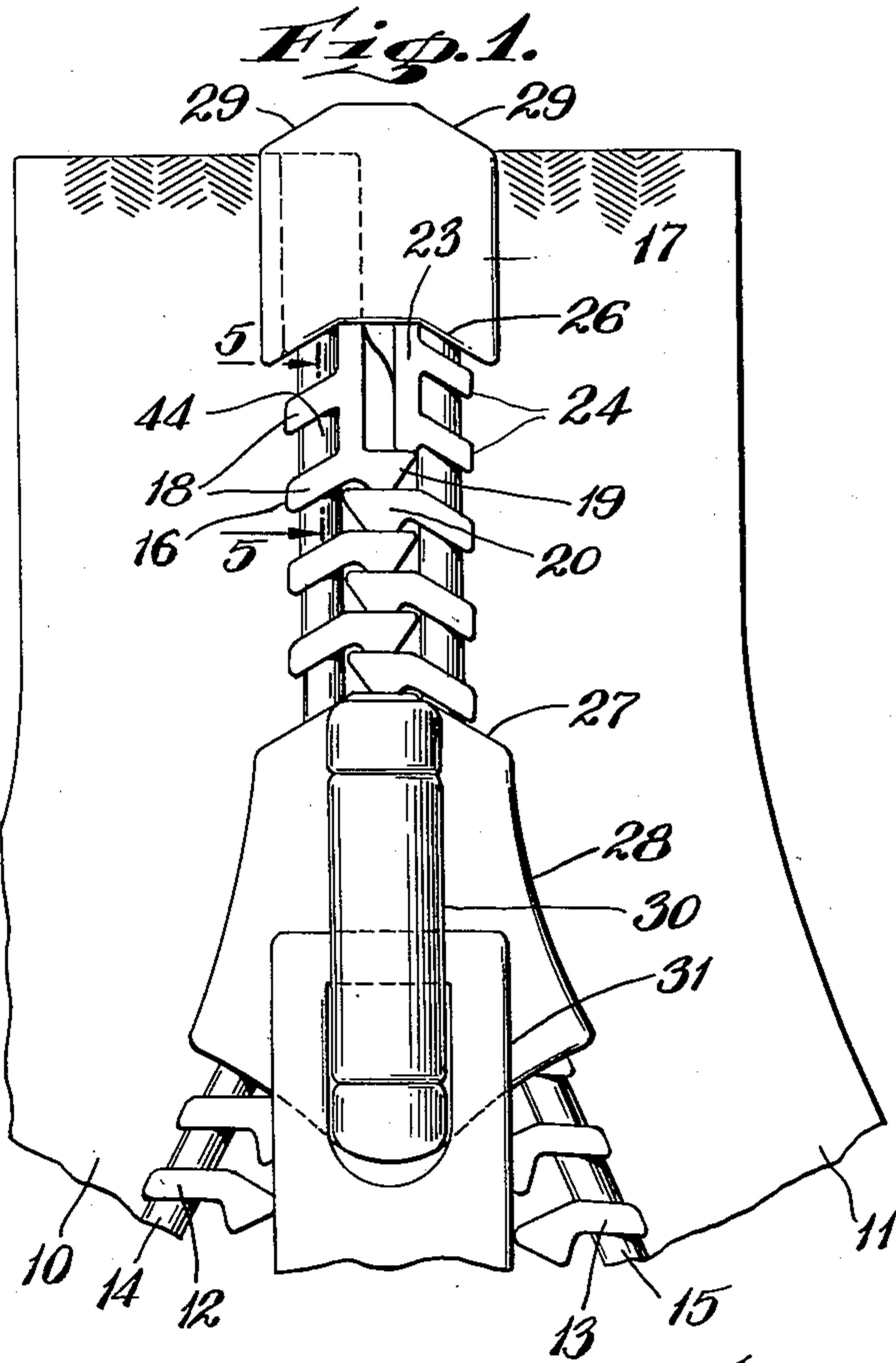

Fig. 2.

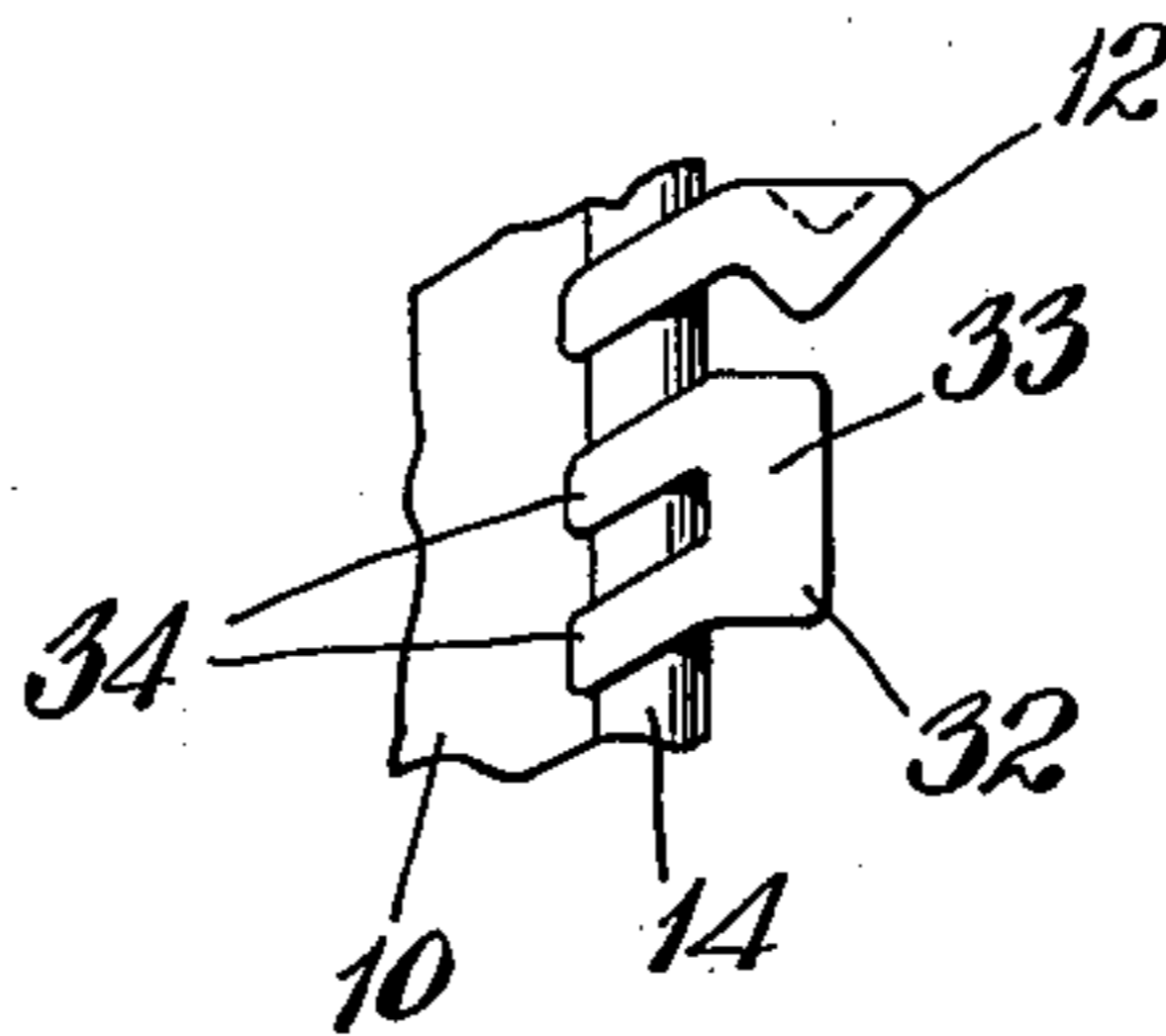

Fig. 5.

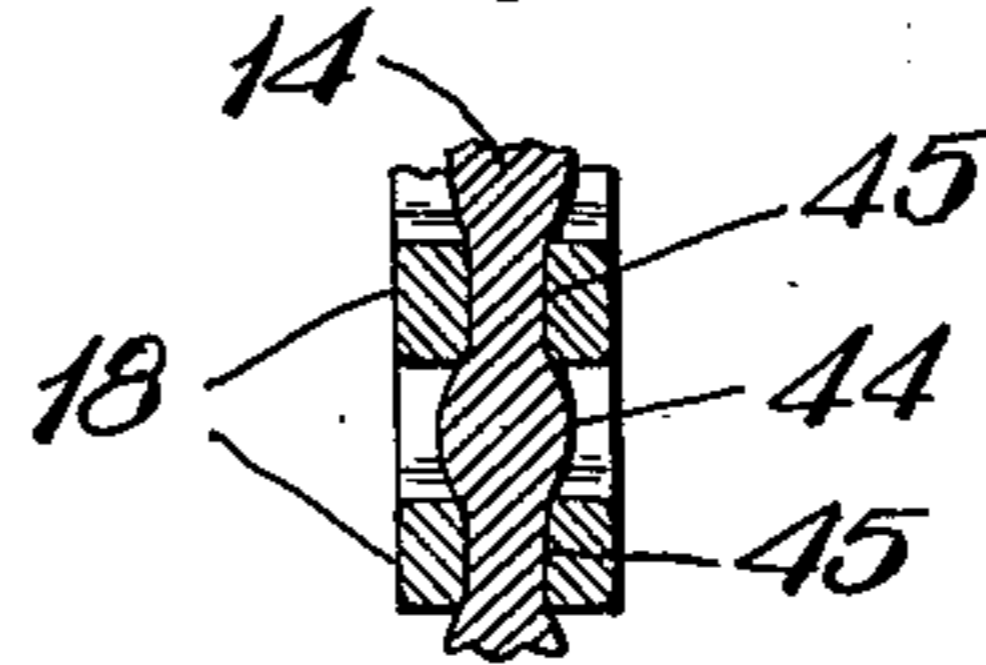

Fig. 3.

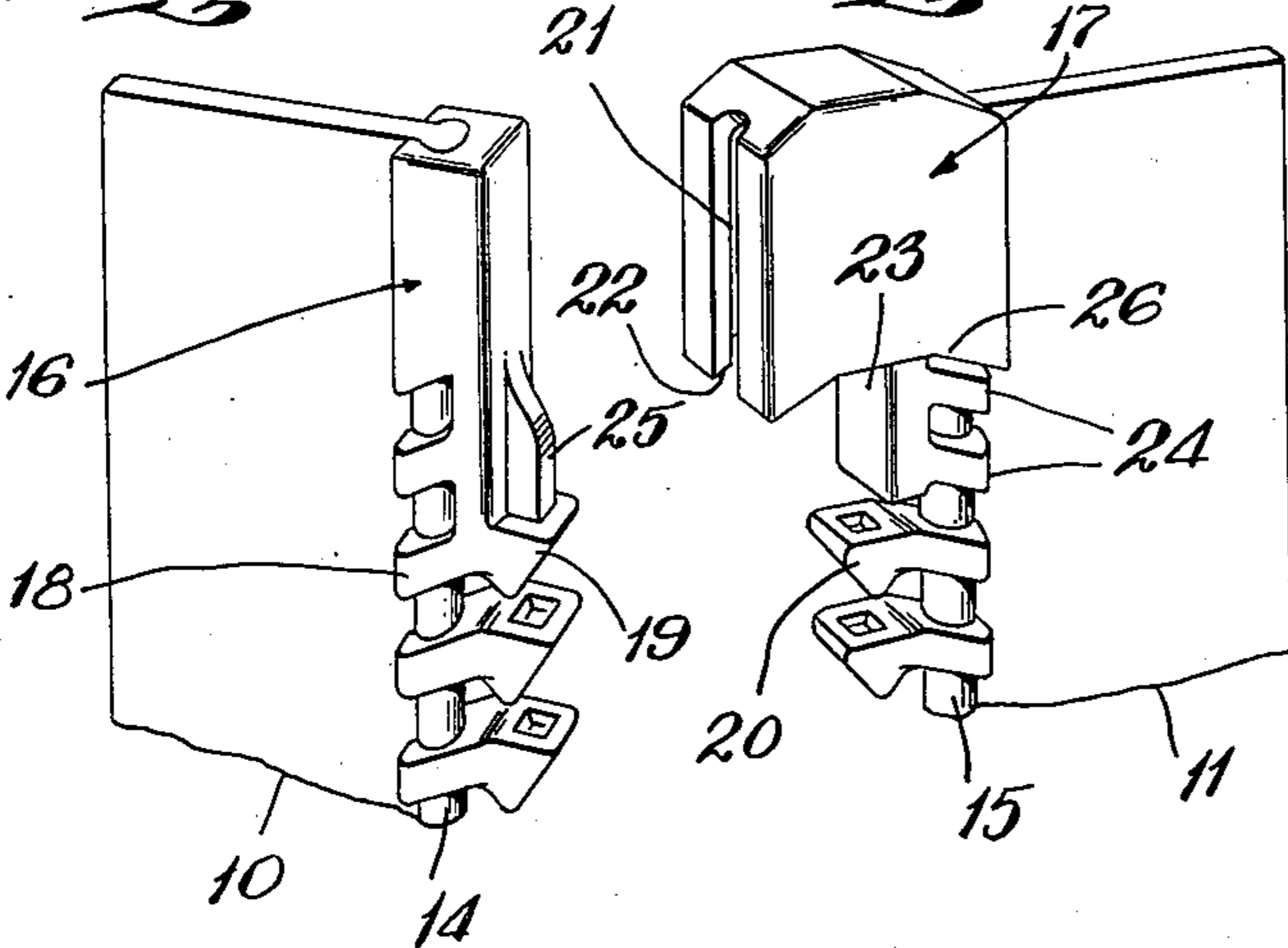

Fig. 4.

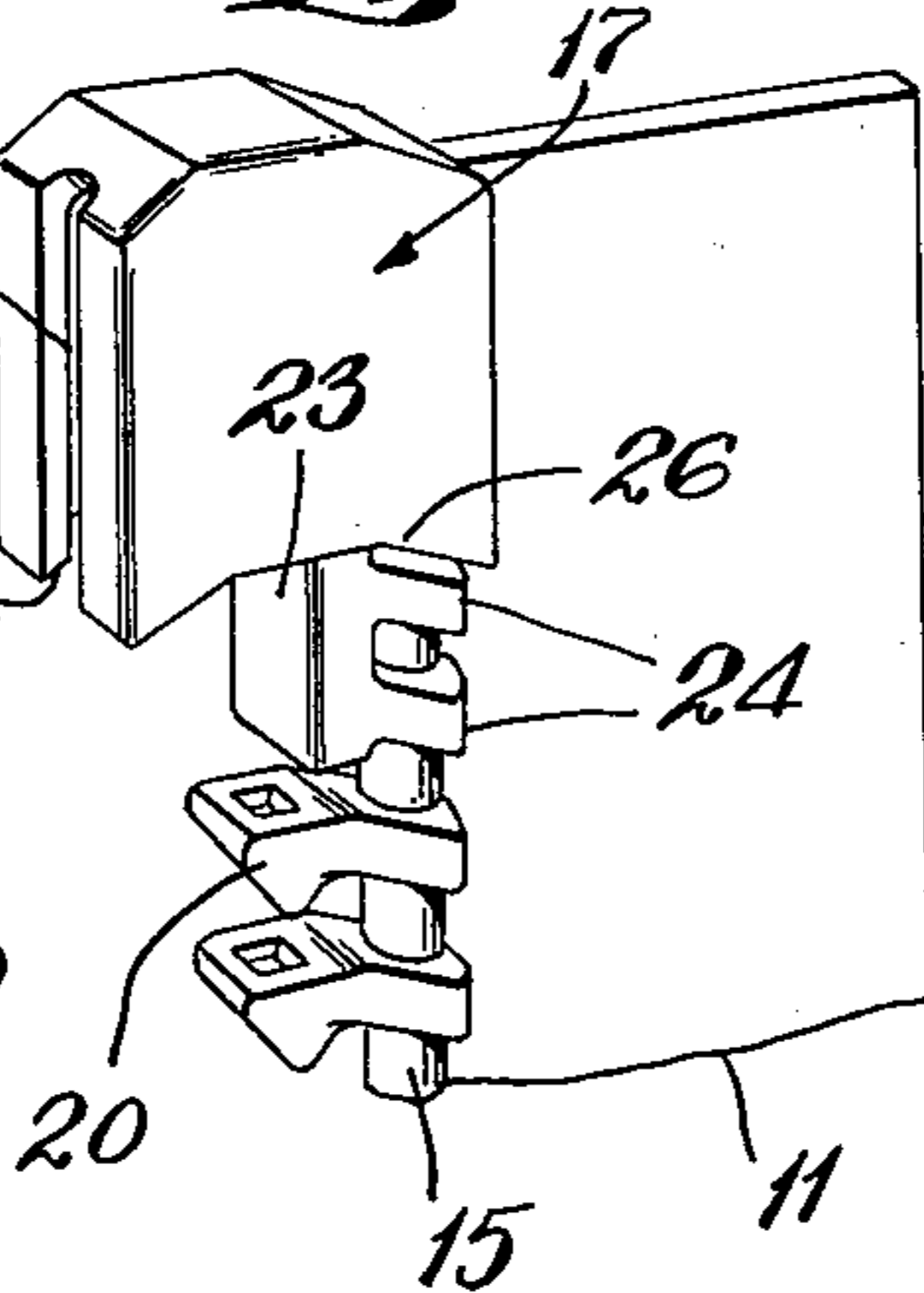
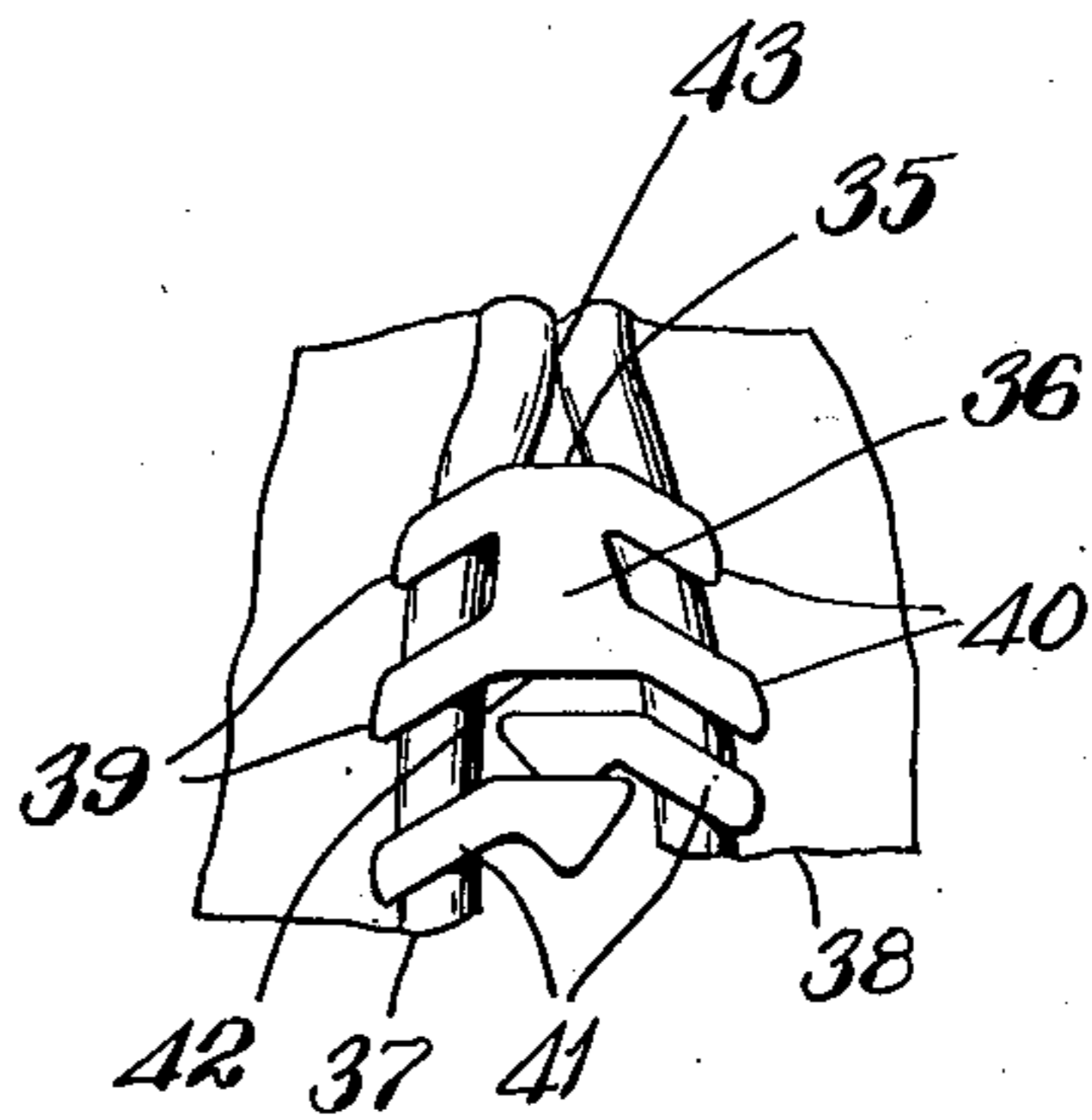

Fig. 6.



INVENTOR
JOHN B. CLARK
BY
Gifford, Scull & Burgess,
ATTORNEYS

UNITED STATES PATENT OFFICE

2,267,079

SEPARABLE FASTENER

John B. Clark, Old Westbury, N. Y., assignor to
Crown Fastener Corporation, Warren, R. I., a
corporation of Delaware

Application February 21, 1941, Serial No. 379,935

11 Claims. (Cl. 24—205)

This invention relates to separable slide fasteners employing stringers adapted to be coupled and uncoupled by a slider movable longitudinally thereof, including fasteners of this kind wherein the stringers are detachable. More particularly the invention relates to the construction of end stops and coupling elements of a fastener of the class described in such manner as to provide two or more prong engagements of the end stops or elements with the stringer tapes in securely retaining the same against displacement from the tapes, and still further in minimizing the engagement of molten metal with the tape in forming die cast couplings or elements directly upon the tape. The novel features of the invention will be best understood from the following description when taken together with the accompanying drawing in which certain embodiments of the invention are disclosed and in which the separate parts are designated by suitable reference characters in each of the views, and in which:

Fig. 1 is a plan view of one end portion of a detachable separable fastener of the class described illustrating one adaptation of the invention.

Fig. 2 is a detail view of the other end portion of one of the stringers of the fastener shown in Fig. 1.

Fig. 3 is a perspective of part of the structure shown in Fig. 1, detached.

Fig. 4 is a view similar to Fig. 3 showing the other part detached from the part shown in Fig. 3.

Fig. 5 is a partial section on the line 5—5 of Fig. 1; and

Fig. 6 is a view similar to Fig. 1 showing the invention applied to the permanent coupling of opposed stringers.

In the construction of separable fasteners of the type and kind under consideration, it has been customary in the formation of end stops or end couplings to provide relatively long body portions extending longitudinally of the stringer tapes. To insure firm coupling of the members with the tapes, it has been essential to utilize some other element to insure firm and positive engagement of the couplings with the tapes. Oftentimes, mounting or reinforcing plates have been used as well as prongs and similar devices, the latter having a tendency to rupture or otherwise weaken the tape structure. Furthermore, in the die casting of members of this type and kind directly upon the stringer tape, relatively large bodies of molten metal are applied to the tape, which, in the construction of larger type of fas-

teners, might have a tendency to char or otherwise weaken the tape fibres. Furthermore, in applying such devices to what are termed chevron or herringbone fasteners, of the type and kind herein later described, these conventional end stops and couplings were distorted with respect to the continuity of the fastener as a whole. By utilizing the pronged structure on the end stops, the continuity of the fastener linkage may be maintained throughout the entire length of the fastener, and in fact, this continuity may be carried out through the contour of the stop itself, thus producing a very neat and finished appearance in the complete device.

For the purpose of illustrating one adaptation of the invention, the same has been illustrated in the accompanying drawing as applied to separable fastener stringers 10, 11 having the chevron or herringbone links 12, 13 arranged and spaced longitudinally of the beaded edges 14, 15 of said tapes. Stringers of this type and kind are disclosed in detail in Patent #2,219,657 dated October 29, 1940, and the links possess the advantages set forth in said patent, namely of the added security of the links upon the stringers by reason of the angular arrangement of the parts of the links attached to the beaded edges 14 and 15 of the tapes. Of course these advantages also prevail in the devices which are hereinafter set forth.

In Figs. 1, 3 and 4 of the drawing, I have shown at one end of the stringers 10 and 11, usually the lower end when stringers of this type and kind are applied to lumber jackets and similar garments, detachable couplings 16 and 17 commonly termed the pin and box parts of a detachable fastener. These parts usually have long body portions extending longitudinally of the tape and are either crimped or die cast directly thereon, depending upon the structure of the members and the method of producing the same, and difficulty has been experienced in securely retaining these members upon the tape as heretofore set forth. To eliminate these objectionable features, the pin part 16 is provided with a number of link or prong portions 18, preferably arranged adjacent the inner end portions thereof. The innermost link or prong 18 has an integral coupling head 19 adapted to engage the end link 20 of the opposed stringer 11 as will clearly appear from a consideration of Figs. 1, 3 and 4 of the drawing.

The box part 17 has a channel 21 therein for the reception of the pin part 16, as is common in other devices of this type and kind, the channel having a slit or opening 22 along the outer side of

the box part to receive the tape of the stringer 10. The side of the box part 17, which is attached to the stringer, has an extending bar portion 23 along the edge of the bead 15. This bar portion has a plurality of link or prong portions 24 which are similar to the prongs 18 in firmly engaging the tape 11. The inner surface of the pin part 16 adjacent the link end 19 has a protruding cam portion 25 which operates upon the surface of the bar 23 in maintaining alignment of the pin part 16 within the box part when these parts are coupled together. It will also appear that the inner end of the box part 17 has an angular recess 26 forming the end stop wall proper of the coupling against which the correspondingly formed end 27 of a slider 28 is adapted to strike. The outer end of the box part has its corners beveled as seen at 29 to maintain the general continuity of the chevron links of the fastener as will readily appear from a consideration of Fig. 1 of the drawing.

The slider 28 may be of any desired form or construction and includes on at least one surface thereof a pivot portion 30 in connection with which a finger piece or pull 31 is coupled.

By utilizing the link or prong members 18, 24 on the couplings 16, 17, a more secure attachment of these couplings is made possible. It will be understood that in pinching or pressing these members on the stringer tapes, individual pressures will be applied to the elements in firmly engaging the tape, irrespective of any irregularities that may prevail in the tape structure. Furthermore, in die casting the members 16 and 17 directly upon the tapes, the secure mounting is maintained while at the same time the amount of metal directly enveloping the tape edge is minimized, thus eliminating the danger of charring the tape, particularly in the construction of the larger type of fasteners. In this connection, it will be understood that while that part of the pin portion 16 which extends into the box part 17 is made continuous, this is not absolutely essential.

At the other end of each of the stringers 10, 11, another stop link or element is employed to prevent detachment of the slider from said ends of the stringer when the fastener is completely closed. In Fig. 2 of the drawing the end portion of one of the stringers, the stringer 10, is shown. Arranged thereon is an end stop element or link 32 which consists of an elongated bar portion 33 arranged upon the surface of the bead 14. Extending from the ends of the bar portion are two links or prongs 34 similar in all respects to the links or prongs 18, 24. Here again, a secure mounting of the end stop is provided on the tape as well as maintaining the other advantageous features set forth.

In Fig. 6 of the drawing, the invention is shown applied to the permanent coupling between two opposed stringers in fasteners wherein the stringers are not completely separable, as is the case with the fastener shown in Fig. 1. In Fig. 6, I have shown at 35 an end stop and coupling of this type and kind having a central body 36 arranged along adjacent and beaded edges of opposed stringers 37, 38. At each side of the body 36, are pairs of mounting links or prongs 39, 40 which are arranged angularly to conform with the contour of the links 41 on the stringers. This arrangement of linkage also carries out the general continuity of the complete fastener as will readily appear. The inner recessed surface 42 of the end stop is substantially similar to the sur-

face 26 and forms a seat upon which a slider end 27, similar to that shown in Fig. 1, may abut. In the construction shown in Fig. 6, the end stop is contracted toward its outer end by tapering the body 36 and by shortening the outer prongs 39, 40 thereof. The purpose of this is to draw together the adjacent beaded edges of the tapes 37 and 38 as indicated at 43, to facilitate attachment of the tapes to suitable supports and to close the gap which would otherwise be formed at the end of the fastener.

By crimping, pinching or otherwise applying the various end stops or couplings to the stringer tape, and in fact in pressure casting these members or elements thereon, the part of the beaded edge of the tape engaged by the prongs of these members or elements will be compressed a greater degree than that part of the beaded edge disposed therebetween. To diagrammatically illustrate this result, I have shown for illustrative purposes in Fig. 5 of the drawing, a partial section taken through the prongs 18 and the bead 14. It will be noted that between the prongs 18, the bead 14 is of greater thickness as at 44 than as at 45 where the prongs engage the bead. The advantages of this construction is to securely retain the end stops against sliding movement longitudinally of the stringers, thus preventing shifting thereof when engaged by the slider. This structure eliminates the objection to the longitudinally extending bodies which have heretofore been employed and which are subject to shifting longitudinally of the stringers, unless prongs or other means are provided, and particularly where such devices are crimped or pinched upon the beaded edge. However, the present structure eliminates any distortion to the tape or the beaded edge thereof, but simply compresses this edge sufficiently to form the intermediate enlarged portion, as at 44, a key which eliminates the possibility of longitudinal shifting of the device on the stringers.

It will appear from a consideration of the several devices that in all cases, the linked end stop or coupling structure comprises a bar portion extending along and abutting the beaded edge of the tape. This bar portion has spaced prongs extending therefrom and engaging said beaded edge, and in utilizing the invention on the chevron type of linkage, the said prongs extend from the bar portion at angles other than 90° to be symmetric with or to carry out the continuity in the complete fastener.

Having fully described my invention, what I claim as new and desire to secure by Letters Patent, is:

1. In separable fasteners employing stringers having links spaced longitudinally of one edge of the tapes thereof coupled and uncoupled by a slider slidably engaging said links, a member arranged upon a stringer tape at one end portion thereof, said member having a part arranged directly upon and extending longitudinally of the link edge of the tape, and said part having prongs spaced longitudinally thereof and engaging the edge of the tape at longitudinally spaced intervals corresponding to the spacing of the links on the tape in securing said member against displacement therefrom.

2. In separable fasteners employing stringers having links spaced longitudinally of one edge of the tapes thereof coupled and uncoupled by a slider slidably engaging said links, a member arranged upon a stringer tape at one end portion thereof, said member having a part arranged

directly upon and extending longitudinally of the link edge of the tape, said part having prongs spaced longitudinally thereof and engaging the edge of the tape at longitudinally spaced intervals corresponding to the spacing of the links on the tape in securing said member against displacement therefrom, and said prongs compressing that part of the tape engaged thereby to form on the tape intermediate said prongs enlarged portions keying the member against movement longitudinally of the tape.

3. An end stop for the tapes of separable fastener stringers, said end stop comprising a member coupling opposed tapes of a fastener adjacent end links on the stringer tapes, said member comprising at least two prongs on each tape spaced longitudinally of the link edge thereof, and said prongs firmly engaging the tape edges without rupturing the tape structure.

4. An end stop for the tapes of separable fastener stringers, said end stop comprising a member coupling opposed tapes of a fastener adjacent end links on the stringer tapes, said member comprising at least two prongs on each tape spaced longitudinally of the link edge thereof, said prongs firmly engaging the tape edges without rupturing the tape structure, and said member comprising detachably coupled parts providing separation of the stringer tapes at said end thereof.

5. An end stop for the tapes of separable fastener stringers, said end stop comprising a member coupling opposed tapes of a fastener adjacent end links on the stringer tapes, said member comprising at least two prongs on each tape spaced longitudinally of the link edge thereof, said prongs firmly engaging the tape edges without rupturing the tape structure, said member comprising detachably coupled parts providing separation of the stringer tapes at said end thereof, one of said parts comprising a box part and the other part a pin part insertable into the box part, and said last named part including an integral link portion adapted to engage an end link on the stringer tape to which the box part is secured.

6. In separable fasteners employing stringers having interengaging links coupling and uncoupling the stringers, a detachable end stop adjacent the end links at one end of the stringers, said end stop comprising a box part on one stringer and a pin part on the other stringer insertable into the box part in coupling said stringers, and both of said parts having adjacent the end links on the stringers integral link portions spaced longitudinally of the stringers and firmly engaging the tapes thereof, and that part of the links on the stringer tapes conforming in contour and arrangement to the links of the stringer tapes.

7. An attachment for separable fastener stringers having coupling links spaced longitudinally of the edges of the tapes thereof, said attachment comprising a link body having link

portions adapted to firmly engage the link edge of a stringer tape at longitudinally spaced intervals corresponding to the spacing of said coupling links, and said spaced link portions having an integral bar portion arranged longitudinally of and in abutting engagement with said edge of the tape leaving the edge portion of the tape exposed intermediate said spaced link portions.

8. An attachment for separable fastener stringers comprising a link body having spaced link portions adapted to firmly engage one edge portion of a stringer tape at longitudinally spaced intervals on said tape edge, said spaced link portions having an integral bar portion arranged longitudinally of and in abutting engagement with said edge of the tape leaving the edge portion of the tape exposed intermediate said spaced link portions, and said link portions extending angularly onto the tape edge at an angle other than 90° to the longitudinal edge of the tape.

9. An end stop for the tapes of separable fastener stringers, said end stop comprising a central body portion tapered to form narrow and wide ends, side portions of said body having longitudinally spaced tape engaging prongs adapted to engage opposed tapes in coupling said tapes together adjacent end links of the stringers, said prongs firmly engaging the tape edges without rupturing the tape structure, and the tapered contour of said central body converging the tape edges beyond and adjacent said end stop.

10. In separable fastener stringers having longitudinally spaced coupling links at the edges of the tape thereof with mounting portions of the links extending angularly onto the edges of the tapes, an end stop on the tapes adjacent end links thereof, the end stop comprising a box part on one stringer and a pin part on the companion stringer insertable into the box part in coupling the stringers, each part having, adjacent the links, a projecting tape-engaging portion extending onto the tape, said projecting portion of each part being arranged at an angle corresponding to the angularity of the mounting ends of said links and spaced from the adjacent end links a distance corresponding to the spacing of the links from each other on each stringer tape.

11. An end stop for the stringers of separable fasteners employing longitudinally spaced coupling links on one edge of each stringer, said end stop comprising a box part on the link edge of one stringer, a pin part on the link edge of the other stringer, the pin part being insertable into the box part in coupling the stringers, each of said parts comprising a portion extending along and outwardly of the edge of its stringer and a stringer engaging portion, said stringer engaging portion of each part projecting along the stringer beyond the first-named portion of each part to extend the attachment of each part on the stringer to a point in close proximity to the end links of the stringers.

JOHN B. CLARK.