

March 4, 1941.

M. S. WELLS

2,234,098

CAN CRUSHER AND BALER

Filed Dec. 6, 1938

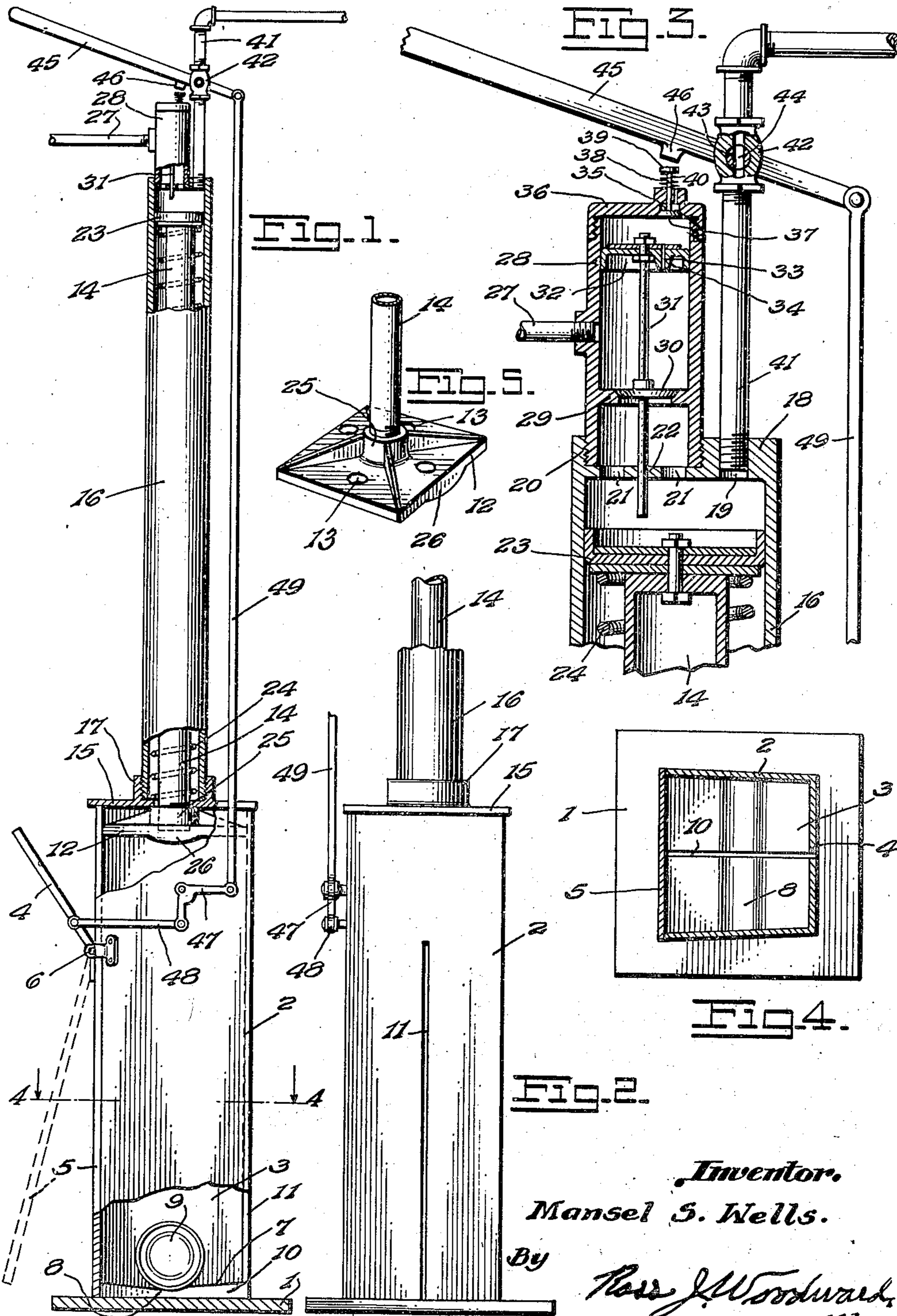

Inventor.
Mansel S. Wells.

By *Ray J. Woodward*
ATTY.

UNITED STATES PATENT OFFICE

2,234,098

CAN CRUSHER AND BALER

Mansel S. Wells, Shinglehouse, Pa.

Application December 6, 1935, Serial No. 244,269

6 Claims. (Cl. 100--71)

This invention relates to a can crusher and baler and more particularly to a machine of this character for use at a garage or filling station for disposing of empty oil cans which are customarily tossed upon a pile, but it is to be understood that the crusher and baler is not restricted to this particular use.

One object of the invention is to provide a crusher and baler including a housing or chamber in which the cans are to be deposited and a plunger which operates in the chamber to apply pressure to the cans and crush and flatten them to form a compact stack about which is engaged binding wire to tightly secure them in baled formation.

Another object of the invention is to provide the machine with an improved arrangement of entrance door and valve operating means for controlling operation of a plunger, the door being closed when the valves are adjusted to cause the plunger to move downwardly in a power stroke and thus eliminating danger of a person's hand becoming caught by being inadvertently thrust inwardly through the entrance during downward movement of the plunger.

Another object of the invention is to so arrange the means for admitting fluid under pressure that accidental downward movement of the plunger will be prevented but such movement assured when a lever is actuated to close the door and open a valve constituting an element of the press.

Another object of the invention is to so mount the plunger that it will be urged upwardly but permitted to be forced downwardly at high pressure and thus assure proper crushing and baling of the cans.

Another object of the invention is to so form the chamber in which the plunger operates that the cans will be centered therein and a compact stack of flattened cans formed which will be of even dimensions and held in a tightly compressed condition during application of the binding wire.

Another object of the invention is to provide a can crusher and baler which is of simple construction and very easy to operate.

The invention is illustrated in the accompanying drawing, wherein:

Fig. 1 is a view showing the improved can crusher and baler partially in side elevation and partially in vertical section.

Fig. 2 is a view looking at the rear of the machine with the upper portions of the plunger and its cylinder broken off.

Fig. 3 is a sectional view taken vertically through the upper portion of the cylinder and associated parts.

Fig. 4 is a sectional view taken transversely through the chamber along the line 4-4 of Fig. 1.

Fig. 5 is a perspective view of the piston and the lower portion of the plunger carrying the same.

This improved can crusher and baler has a base 1 from which rises a housing 2 defining a chamber 3 in which the cans are crushed and pressure applied to reduce a number of cans to a compact mass or stack about which wire is secured to form a bale. The housing may be of any desired diameter and height and is preferably rectangular in cross section, as shown in Fig. 4. The housing is open at its front and in order to close this open front, there have been provided upper and lower doors 4 and 5 which are hingedly mounted, as shown at 6, in order that they may be opened and closed. While upper and lower doors have been shown, it is to be understood that other specific closure means may be provided if found practical. The bottom 7 of the housing is formed with a transversely extending recess 8 to center a can 9 dropped into the housing and portions of the bottom at opposite sides of the recess slope somewhat toward the recess so that when a can is dropped into the housing it will roll along the bottom and come to rest in the recess. A slot 10 is formed across the bottom transversely of the seat or recess 8 and this slot registers with the lower end of a slot 11 extending vertically in the rear wall of the housing midway the width thereof so that after a number of cans have been crushed and are held under pressure, a wire may be passed about the stack of flattened cans after opening the door 5 and its ends twisted together or otherwise secured to hold the cans in baled formation. The door 5 is kept closed except when securing the wire about the stack of cans, but the upper door 4 is normally left open so that cans may be inserted and automatically moved to a closed position when the machine is operated for a crushing and compressing operation.

In order to crush and compress the cans, there has been provided a piston 12 which is in the form of a strong metal plate of dimensions adapting it to fit snugly within the chamber 3 of the housing 2 and slide vertically therein. Openings 13 are formed in the piston to provide air passages and allow the piston to slide freely. This

piston is mounted at the lower end of a plunger or piston rod 14 which extends through an opening in the head or top 15 of the housing 2 and is of tubular formation to reduce its weight.

5 The plunger extends longitudinally in a cylinder 16 disposed vertically over the housing and having its lower end mounted in a collar 17 rising from the top of the housing. The cylinder may be of any length and diameter desired and, at

10 its upper end, has a head 18 in which is formed a threaded opening 19 and a threaded socket 20 having openings 21 at its bottom about a center opening 22. A cup 23 of the type used upon reciprocating air pumps is mounted at the upper

15 end of the plunger 14 and, in order to urge the plunger upwardly, there has been provided a coiled spring 24 disposed in the cylinder about the plunger with its upper end abutting the cup and its lower end resting on the top of the hous-

20 ing, as shown in Fig. 1. Upward movement of the plunger is limited by engagement of the collar 25 of the piston 12 with the inner or under face of the cover 15. Below this collar the piston is formed with a depending rib or boss 26 which

25 extends the full width of the piston and is provided to engage the cans and force them into the recess so that when other cans are dropped into the housing they will become centered. This depending boss also serves to reinforce the cen-

30 tral portion of the piston and prevent fracture or other damage when the piston is subjected to pressure.

The plunger is to be forced downwardly in a power stroke by fluid under pressure, such as

35 compressed air, and in order to control the flow of this compressed air from the feed pipe 27 into the upper end of the cylinder, there has been provided a valve casing 28 which is of cylindrical formation and extends upwardly from the upper

40 end of the cylinder 16 with its lower end screwed into the socket 20. An annular valve seat 29 is formed about walls of the valve casing below the feed pipe for engagement by a valve disc 30 carried by a stem 31 which extends vertically in the

45 casing 28 axially thereof and its upper end is secured through a piston 32 which fits snugly in the valve casing and is slidable longitudinally therein above the air inlet. It will thus be seen that the valve disc is operatively connected with

50 the piston and will be moved into and out of engagement with the valve seat 29 when the piston is moved longitudinally in the casing by air pressure. A small perforation 33 is formed through the piston 32 in order that air pressure above

55 and below the piston may be equalized at certain times and allow the weight of the valve disc and piston to carry the valve disc downwardly into engagement with the valve seat, and it should be noted that about this perforation the piston

60 is formed with a depending boss 34 which tapers downwardly and reduces likelihood of the perforation becoming clogged by particles of foreign matter which may enter the valve casing with the compressed air from the pipe 27.

65 An air outlet 35 is formed through the head 36 of the valve casing and flow of air through this outlet is controlled by a valve 37 which has its stem 39 projecting upwardly and terminating in a head 39 engaged by a spring 40 which

70 urges the valve upwardly to a closed position. When this valve is closed air passing through the perforation 33 will cause pressure to be equalized above and below the piston 32 and the valve 30 will be held closed by its weight and also by

75 pressure exerted thereon. When, however, the

valve 37 is opened and air allowed to escape from the upper portion of the valve casing, pressure of air against the under surface of the piston 32, which is of greater area than the valve 30, will cause the piston to be shifted upwardly and the

5 valve 30 will be lifted from the seat 29 to an open position and the compressed air may then enter the cylinder 16 to act upon the cup or piston 23 and force the plunger 14 downwardly so that the

10 piston 12 will be moved downwardly in the housing 2 and crush and flatten a can therein.

During upward movement of the plunger 14, air must be allowed to escape from the cylinder 16, and in order to do so, there has been provided an outlet pipe 41 which may be of any length

15 desired. A valve 42 is mounted in the pipe 41 and is of the plug type, the plug 43 being formed with a bore 44 for permitting escape of air when the plug is in the open position shown in Fig. 3. An operating lever 45 is provided for the valve

20 plug and this lever carries a depending lug 46 disposed over the head 39 so that when the lever is swung downwardly to close the valve 42, the valve 37 will be opened by pressure applied to the head 39 of its stem. The valve 42 being

25 closed and the valve 37 in open position, air will move the valve 30 to its open position and then flow through the openings 21 into the cylinder 16 to act upon the cup 23 and force the plunger

30 downwardly in a power stroke. When the lever is returned to its normal position, the valve 37 will be closed by the spring 40, and since the valve 30 will then close and the valve 42 be opened, the spring 24 will force the plunger upwardly to

35 its initially raised position, air in the cylinder above the cup being forced out through the pipe 41 during this upward movement of the plunger to its normal position.

When the plunger is forced downward in a power stroke, there would be danger of a person

40 being injured if his hand were extending into the housing 2 through the inlet at the front thereof after dropping a can into the housing. It is, therefore, desirable to have the door 4

45 closed during downward movement of the piston 12 and the plunger 14 and, in order to do so, there has been provided a bell crank lever 47 which is pivotally mounted at one side of the housing and has one arm connected with the door

50 4 by a link 48 and its other arm connected with the rear end of the lever 45 by a link or rod 49.

When this can crusher and baler is in use, it is set up at a convenient location in a garage or

55 filling station and the pipe 27 connected with a storage tank or other convenient source of air under pressure. Under normal conditions, the door 4 is open and cans may be dropped into the housing through the open front thereof. As each can is dropped into the housing, the lever 45 is

60 grasped near its front end and swung downwardly to close the valve 42 and open the valve 37. Air will then act upon the piston 32 to open the valve 30 and air under pressure enters the cylinder to force the plunger 14 downwardly in the

65 cylinder 16. During movement of the lever to adjust the valves 37 and 42, the door 4 will be closed and there will be no danger of a person's hand becoming caught under the plunger and injured, it being obvious that the lever cannot

70 be moved into position to close the valve 42 and open the valve 37 until the hand has been moved out of the way and the door closed by action of the bell crank lever 47 and the rods or links 48 and 49. When the piston engages the can which

75 has come to rest in the seat or recess 8, pressure

applied to the can by the piston will crush and flatten the can and the rib or boss 26 will cause a portion of the can to be depressed into the recess and form a recess for centering the next can dropped into the housing. The cans are dropped into the housing one at a time and, as each is crushed and flattened to form a compact stack of flattened cans, the lever is moved to open the valve 42 and allow closing of the valve 37. Pressure will then be equalized above and below the piston 28 and the air will act upon this piston to close the valve 30 and shut off flow of compressed air into the housing from the valve casing 29. The spring 24 will then force the plunger upwardly and return the piston 12 to the raised position of Fig. 1, where it will be brought to a stop by engagement of its collar 25 with the head or top of the housing. The door 5 will be opened when the lever is moved to the normal position of Fig. 1, and as soon as the piston 12 is in its raised position, another can may be dropped into the housing to be crushed, as previously set forth.

After a desired number of cans have been crushed and pressed into a compact mass or stack within the housing 2, the door 5 is opened and a binding wire passed through the chamber 3 between the piston and the top of the stack of cans. The piston will then be shifted downwardly onto the stack of cans to apply pressure thereto and the portion of the wire which projects rearwardly from the housing through the slot 11 will be bent downwardly and then passed inwardly and forwardly under the stack of cans through the slot 10, the protruding forward portion of the wire being then drawn upwardly after being pulled tightly into place and the two ends of the wire twisted together to hold the wire firmly about the stack of cans and form a bale which will be removed from the housing when the piston is shifted upwardly to its raised position. The door 5 may then be closed and the machine is ready for crushing and baling other cans.

It is to be understood that the invention is not restricted to the specific details of construction illustrated but may be modified within the scope of the appended claims. It is also to be understood that instead of compressed air, other mediums, such as hydraulic pressure or the like, may be employed.

Having thus described the invention, what is claimed is:

1. A can crusher and baler comprising a housing disposed vertically, a closure for said housing movable into and out of closed position, a piston slidable vertically in said housing, a cylinder rising from said housing, a plunger extending from said piston into said cylinder and slidable vertically therein and yieldably held raised, a valve casing communicating with the upper end of said cylinder, a feed pipe for fluid under pressure communicating with the valve casing, a valve in said casing between the feed pipe and the cylinder, a piston in said casing between the feed pipe and the upper end of the casing, a stem connecting said valve with said piston to shift the valve to an open position when the piston is shifted upwardly by fluid pressure, said piston having a perforation therein to permit equalizing of pressure above and below the piston and closing of the valve, an opening at the top of said casing, an inwardly opening valve for the opening yieldably held closed, a discharge pipe for said cylinder extending

from the upper end thereof, a valve for said pipe, actuating means for the pipe valve adapted to open the valve at the top of the casing when the pipe valve is closed, a lever pivoted to said housing, means connecting said lever with the actuating means, and a link connecting the lever with said closure for closing the closure when the valve actuating means is moved in a direction to close the pipe valve and open the valve at the top of the casing and permit movement of the valve within the casing to an open position and effect downward movement of the plunger and the piston in a power stroke to crush cans in the housing and compress the flattened cans into a compact mass.

2. A can crusher and baler comprising a housing disposed vertically and having an inlet, a closure for the inlet normally open, a piston slidable vertically in said housing, a cylinder rising from said housing, a plunger slidable vertically in said cylinder and normally held raised and having its lower end extending into said housing and connected to said piston, a discharge pipe leading from the upper end of said cylinder, a valve casing rising from said cylinder, a feed pipe for fluid under pressure communicating with said casing, valve means in said casing for controlling flow of fluid therefrom into said plunger to force the cylinder downwardly in a power stroke, an upwardly opening check valve having a stem extending outwardly through the top of said casing, actuating means for the valve of the discharge pipe adapted to engage the stem of the check valve and open the same when the valve of the discharge pipe is closed, and means actuated by said actuating means for shutting the closure when the valve of the discharge pipe is closed and the check valve opened.

3. A can crusher and baler comprising a housing having an inlet at one side, a closure for the inlet of said housing, a piston slidable longitudinally in said housing, a cylinder extending from one end of said housing, a plunger slidable longitudinally in said cylinder and yieldably held in its normal position with its inner end extending into the housing and connected to said piston, a valve controlled outlet pipe leading from the outer end of said cylinder, a valve casing communicating with the outer end of said cylinder and having a valve seat therein and an inlet for fluid under pressure intermediate the valve seat and the outer end of the casing, an outwardly opening valve in said casing for seating against said valve seat, a piston connected with said valve and located between the fluid inlet and the outer end of the casing and constituting means for opening the valve when acted upon by fluid under pressure in the casing, an inwardly opening check valve at the outer end of said casing having an outwardly extending stem, a lever for actuating the valve of the outlet pipe adapted to engage the stem of the check valve and open the same when the valve of the outlet pipe is closed, and means connecting the closure with said lever for closing the closure when the pipe valve is closed and the check valve opened.

4. A can crusher and baler comprising a housing having an inlet, a closure for the inlet of said housing normally open, a piston slidable longitudinally in said housing, a cylinder extending from one end of said housing, a valve controlled discharge pipe at the outer end of said cylinder, a plunger slidable longitudinally in said

cylinder and yieldably held raised with its inner
 end connected to said piston, a piston carried by
 said plunger within the cylinder, a valve casing
 communicating with the outer end of said cylin-
 5. der, a feed pipe for fluid under pressure com-
 municating with said casing, an outwardly open-
 ing valve in said casing for controlling flow of
 fluid into said cylinder to impart a power stroke
 to the cylinder and the piston, an inwardly
 10. opening check valve at the outer end of said
 casing, an actuating member for the discharge
 pipe valve constituting means for opening the
 check valve when moved to close the valve of
 the discharge pipe, and an operative connection
 15. between the actuating member and the closure
 for closing the closure when the valve of the dis-
 charge pipe is closed.

5. A can crusher and baler comprising a hous-
 ing disposed vertically and having an inlet, a
 20. closure for said inlet movable into and out of
 closed position, a piston slidable vertically in
 said housing and yieldably held raised and when
 moved downwardly in a power stroke adapted to
 crush cans in the lower portion of the housing
 25. and build up a compact mass of flattened cans
 therein, a cylinder rising from the top of said
 housing about an opening therein, a plunger
 extending from said piston into said cylinder
 and slidable vertically therein, a valve controlled
 30. outlet at the top of said cylinder, valve con-
 trolled means for admitting fluid under pressure
 into the upper end of said cylinder for forcing
 the plunger and the piston downwardly in a

power stroke, said fluid inlet means including a
 main valve and a normally closed check valve
 for controlling opening of the main valve, an
 actuating lever for the outlet valve constituting
 means for opening the check valve when the 5
 outlet valve is closed, and a connection between
 the actuating lever and said closure for closing
 the closure when the actuating lever is moved
 to position for closing the outlet valve and open- 10
 ing the check valve to allow opening of the main
 valve and consequent flow of fluid under pressure
 into the cylinder above the plunger to cause
 downward movement of the plunger and piston.

6. A can crusher and baler comprising a hous- 15
 ing formed with an inlet, a closure for the inlet
 movable into and out of closed position, a piston
 slidable vertically in said housing from raised
 position at the top of the housing to lowered
 position and when moved downwardly in a power
 stroke being adapted to crush cans therein and 20
 build up a compact mass of crushed cans for
 baling, valve controlled fluid operated means for
 rapidly moving the piston downwardly in a power
 stroke, a valve controlled outlet for the cylinder,
 an actuating lever for the valve of the outlet 25
 constituting operating means for the valve of
 said fluid operated means, and means connect-
 ing said actuating lever with said closure for
 closing the closure prior to downward movement
 of the piston and holding the closure closed 30
 during the downward movement of the piston
 in a power stroke.

MANSEL S. WELLS.