



(19) **United States**

(12) **Patent Application Publication**  
**Jamali et al.**

(10) **Pub. No.: US 2024/0319509 A1**

(43) **Pub. Date: Sep. 26, 2024**

(54) **POLARIZATION-SELECTIVE VARIFOCAL LIQUID LENS**

*G02B 5/30* (2006.01)

*G02B 26/00* (2006.01)

(71) Applicant: **Meta Platforms Technologies, LLC**,  
Menlo Park, CA (US)

(52) **U.S. Cl.**

CPC ..... *G02B 27/0172* (2013.01); *G02B 3/14*  
(2013.01); *G02B 5/3016* (2013.01); *G02B*  
*26/004* (2013.01)

(72) Inventors: **Afsoon Jamali**, Issaquah, WA (US);  
**Changwon Jang**, Bellevue, WA (US);  
**Sandro Pintz**, Menlo Park, CA (US)

(57)

**ABSTRACT**

A varifocal liquid lens includes a body filled with two different fluids separated by an interface of a variable curvature across a clear aperture of the varifocal liquid lens. At least one of the first or second fluids is birefringent, such that a refractive index difference between the first and second fluids and resulting optical power of the varifocal liquid lens is dependent on polarization of impinging light. At a first light polarization, the first and second fluids may be matched in refractive index, while at a second, orthogonal light polarization, the first and second fluids may be mismatched in refractive index, whereby the first interface between the first and second fluids may have a variable, non-zero optical power for the second polarization while having a substantially non-variable, zero optical power for the first polarization of light.

(21) Appl. No.: **18/734,641**

(22) Filed: **Jun. 5, 2024**

**Related U.S. Application Data**

(62) Division of application No. 17/231,824, filed on Apr. 15, 2021.

**Publication Classification**

(51) **Int. Cl.**

*G02B 27/01* (2006.01)

*G02B 3/14* (2006.01)

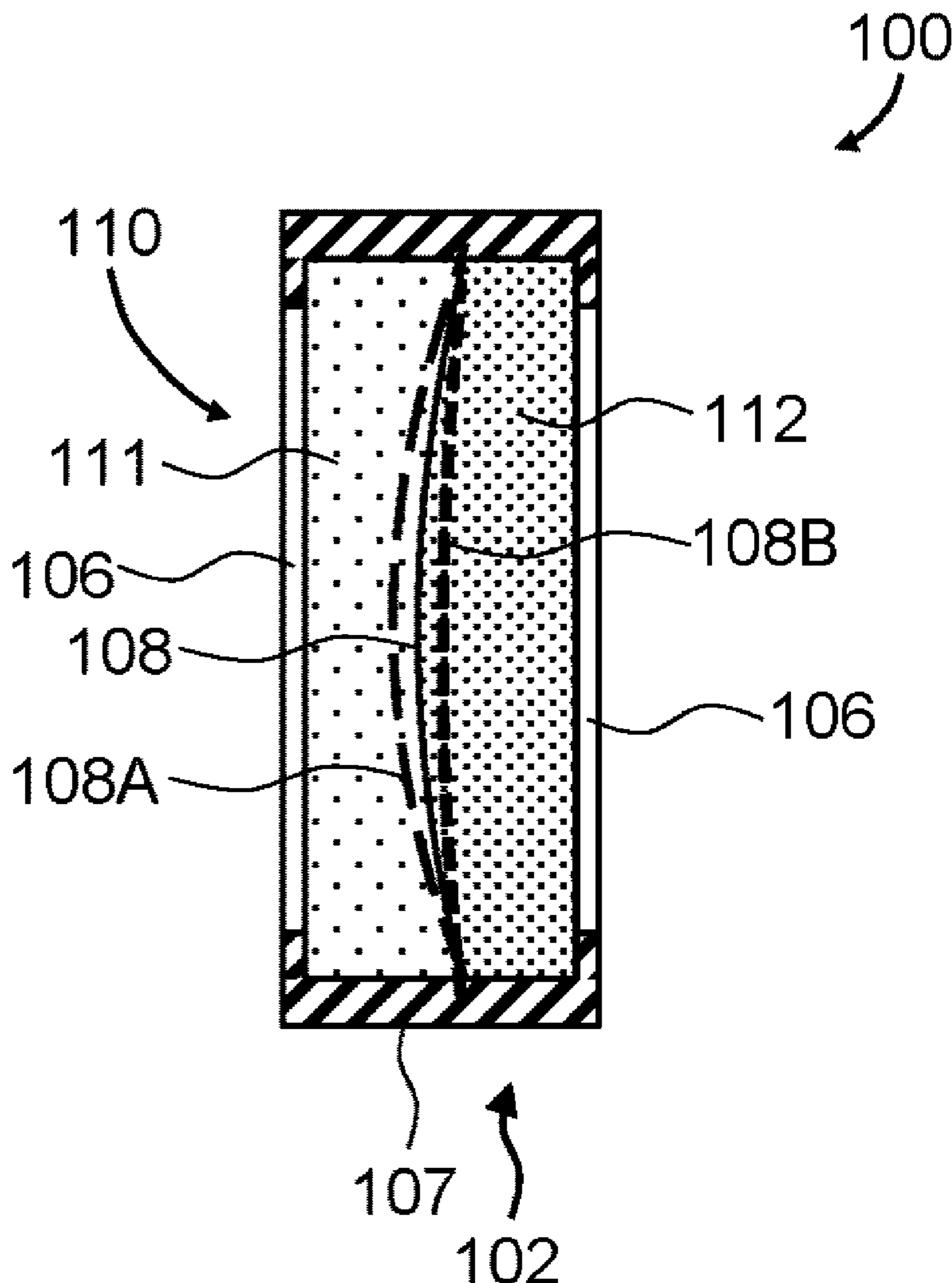

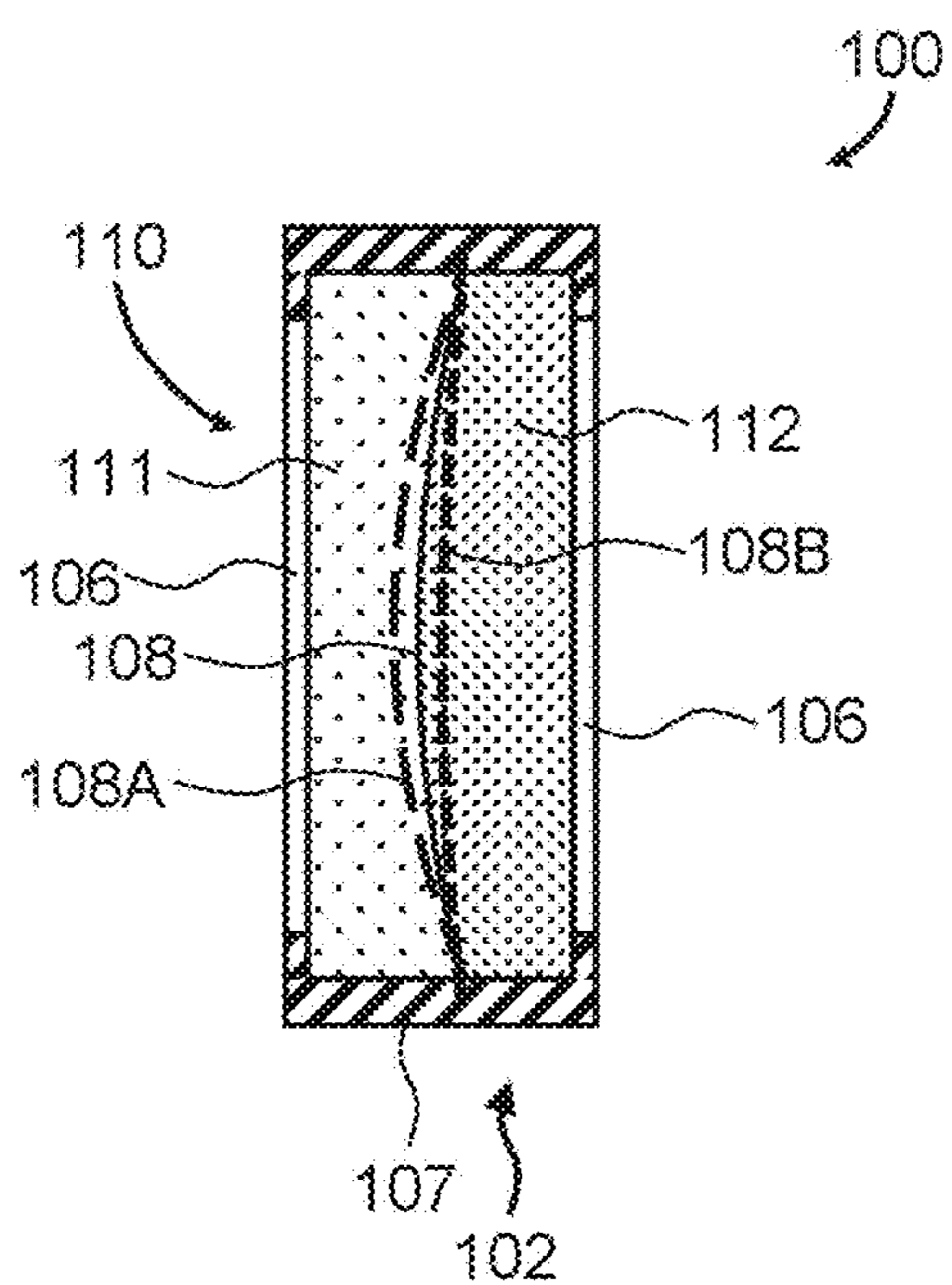

FIG. 1A

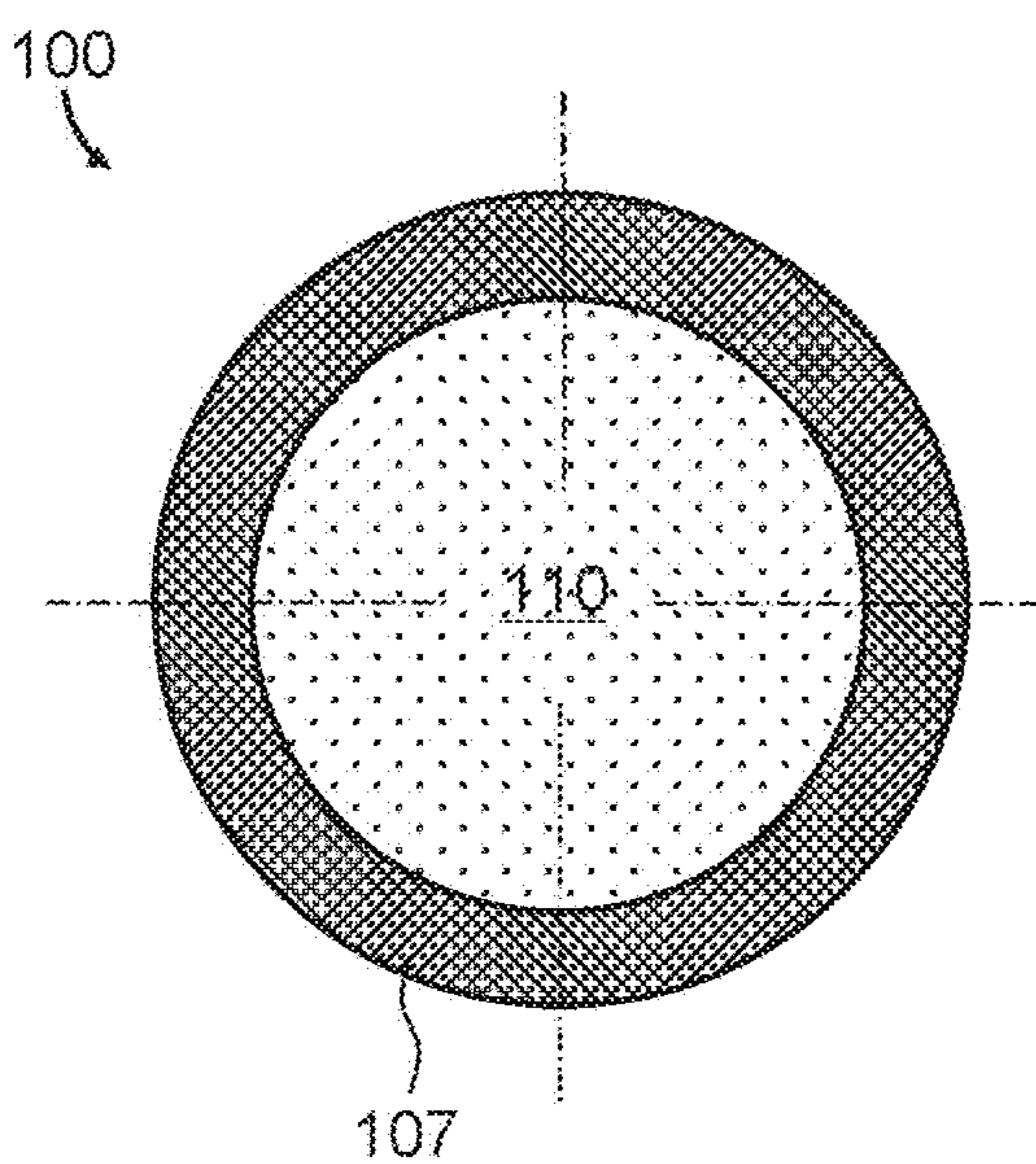

FIG. 1B

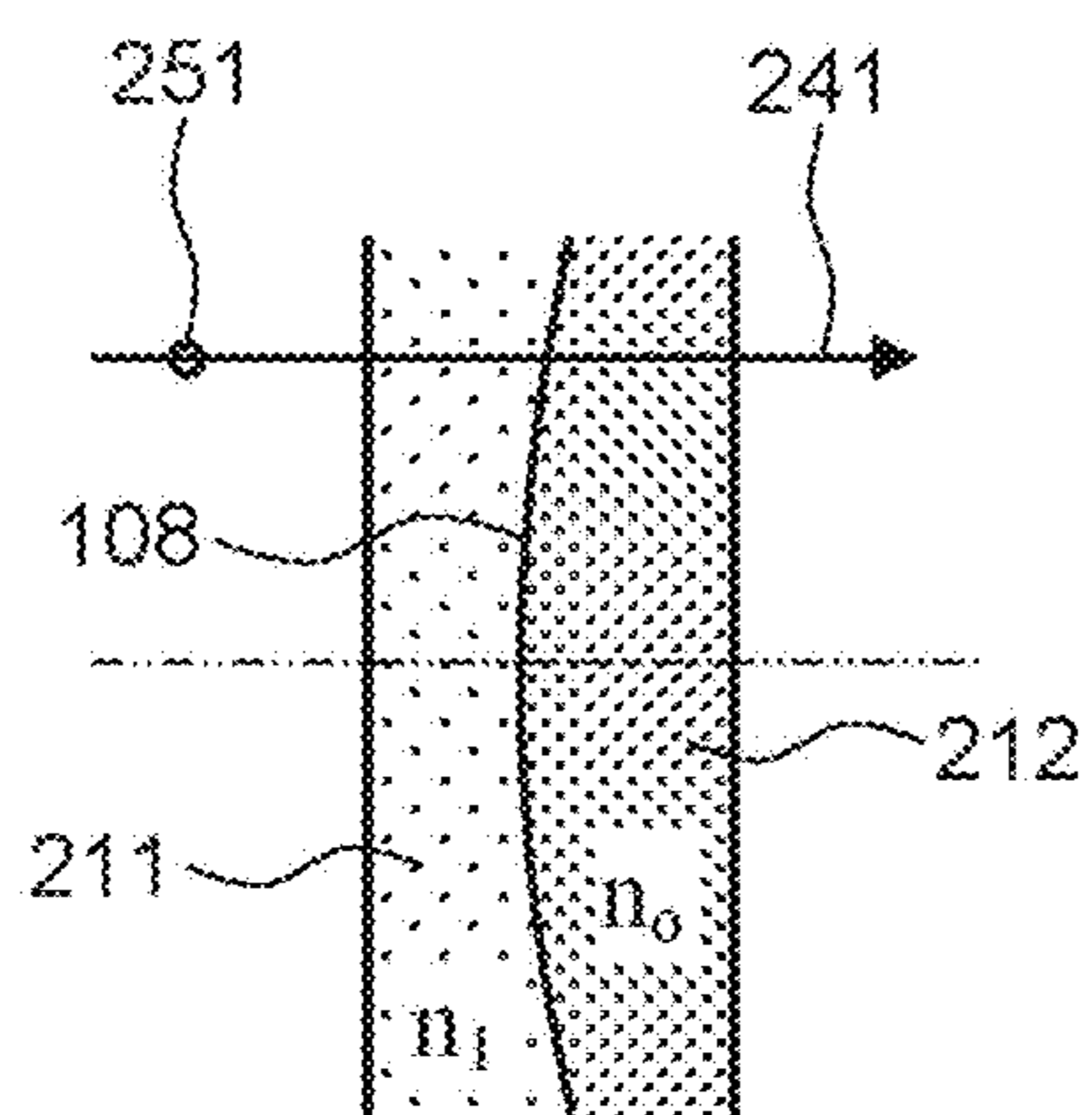

FIG. 2A

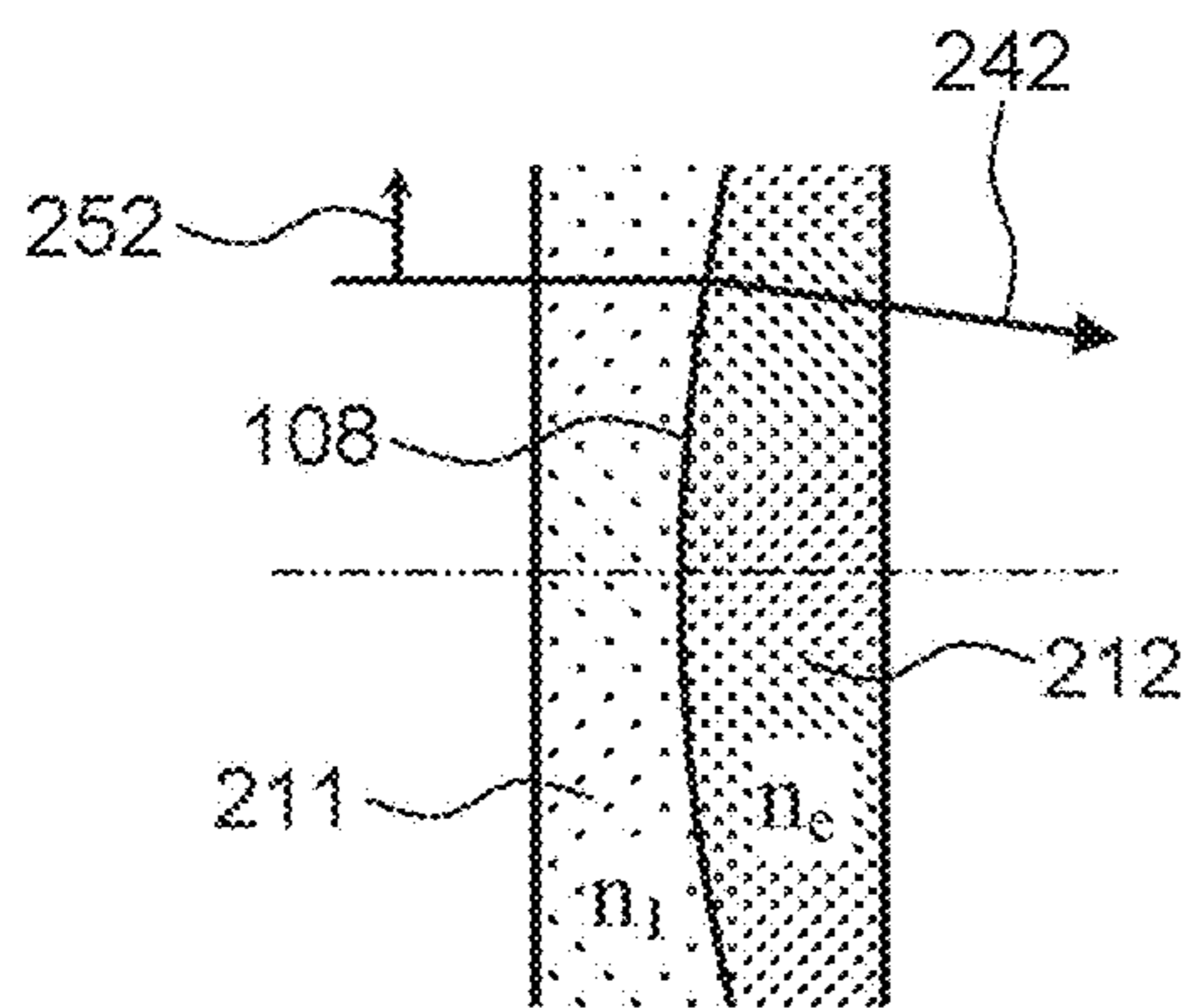

FIG. 2B

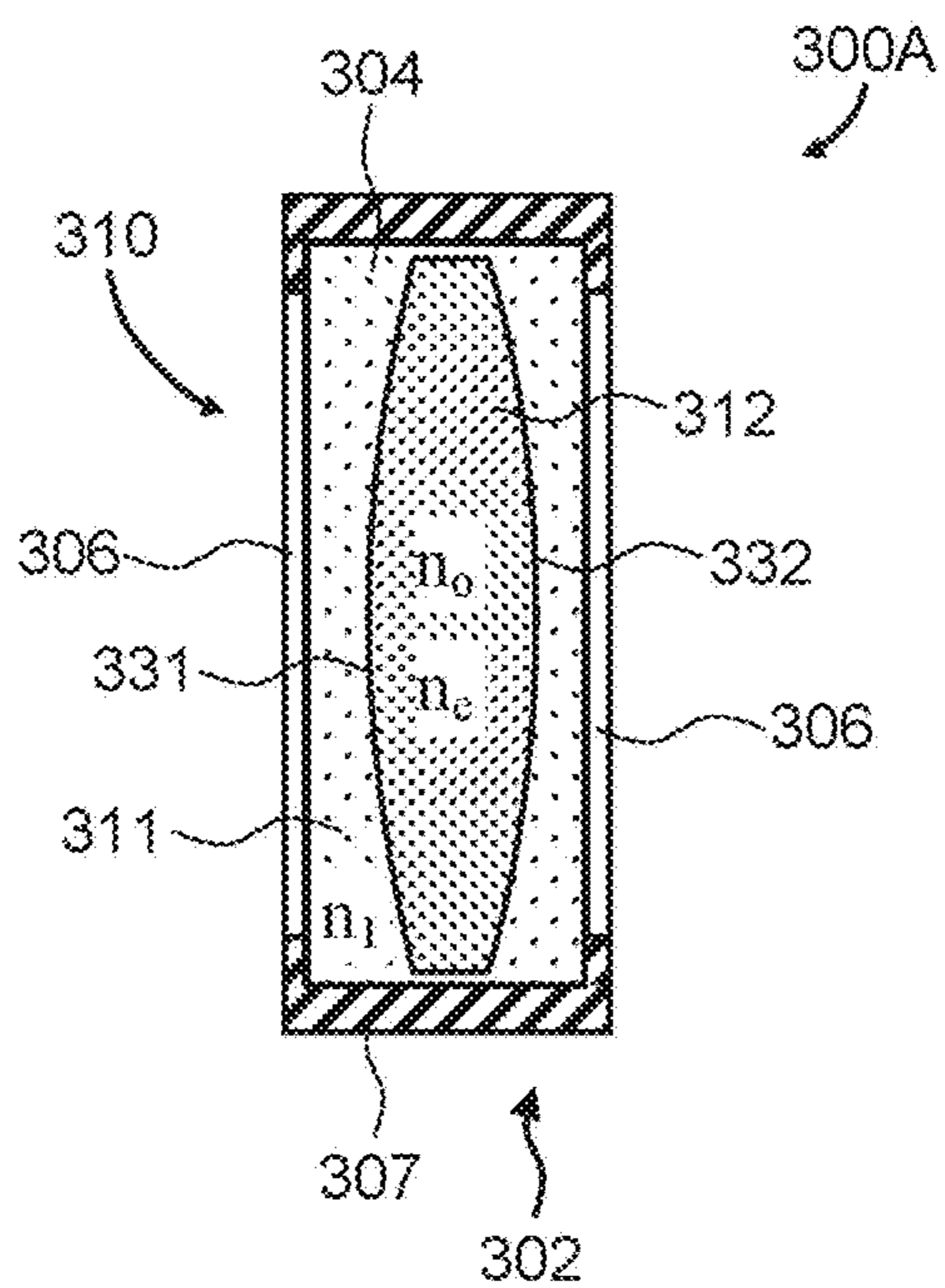

FIG. 3A

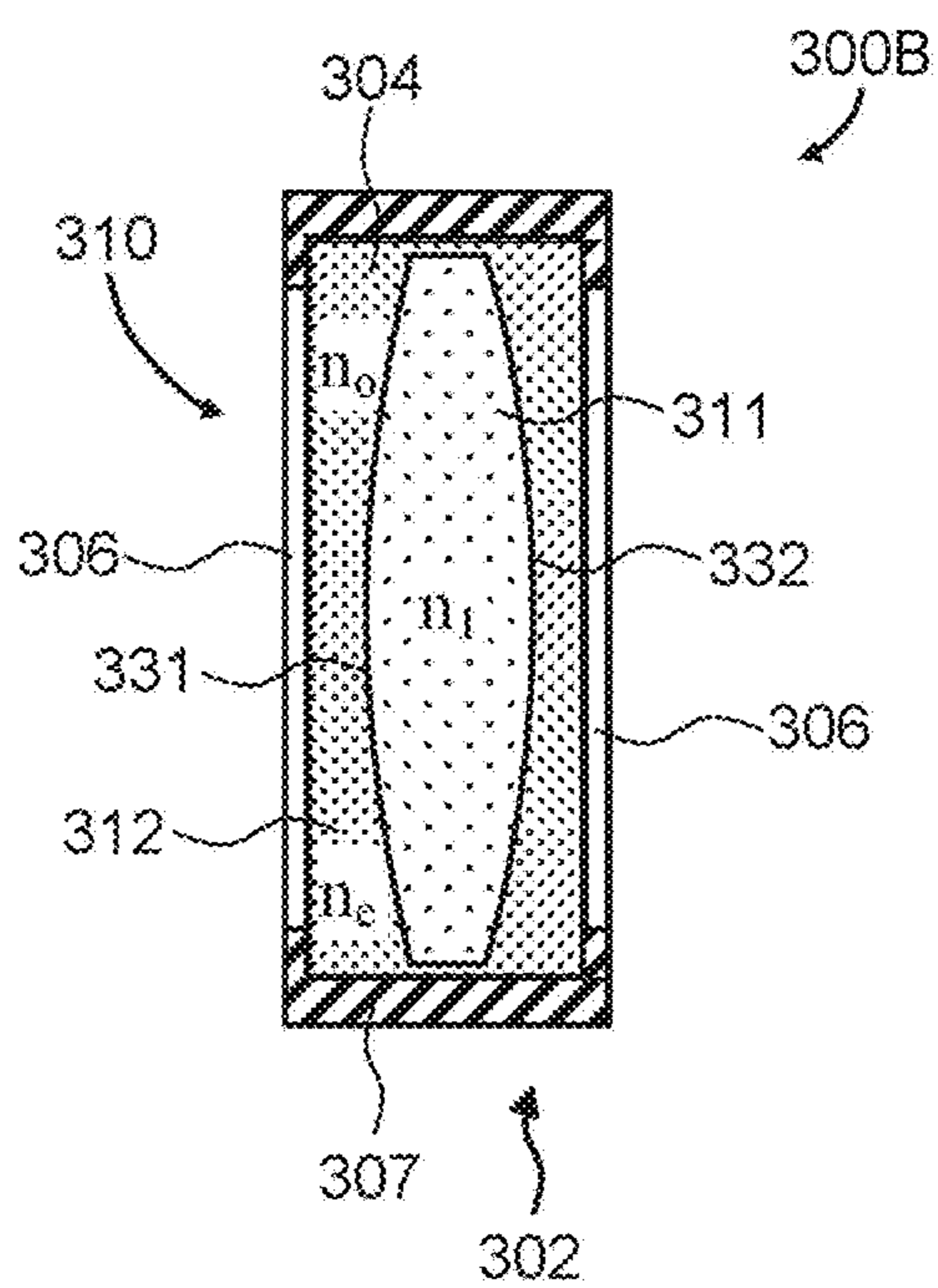
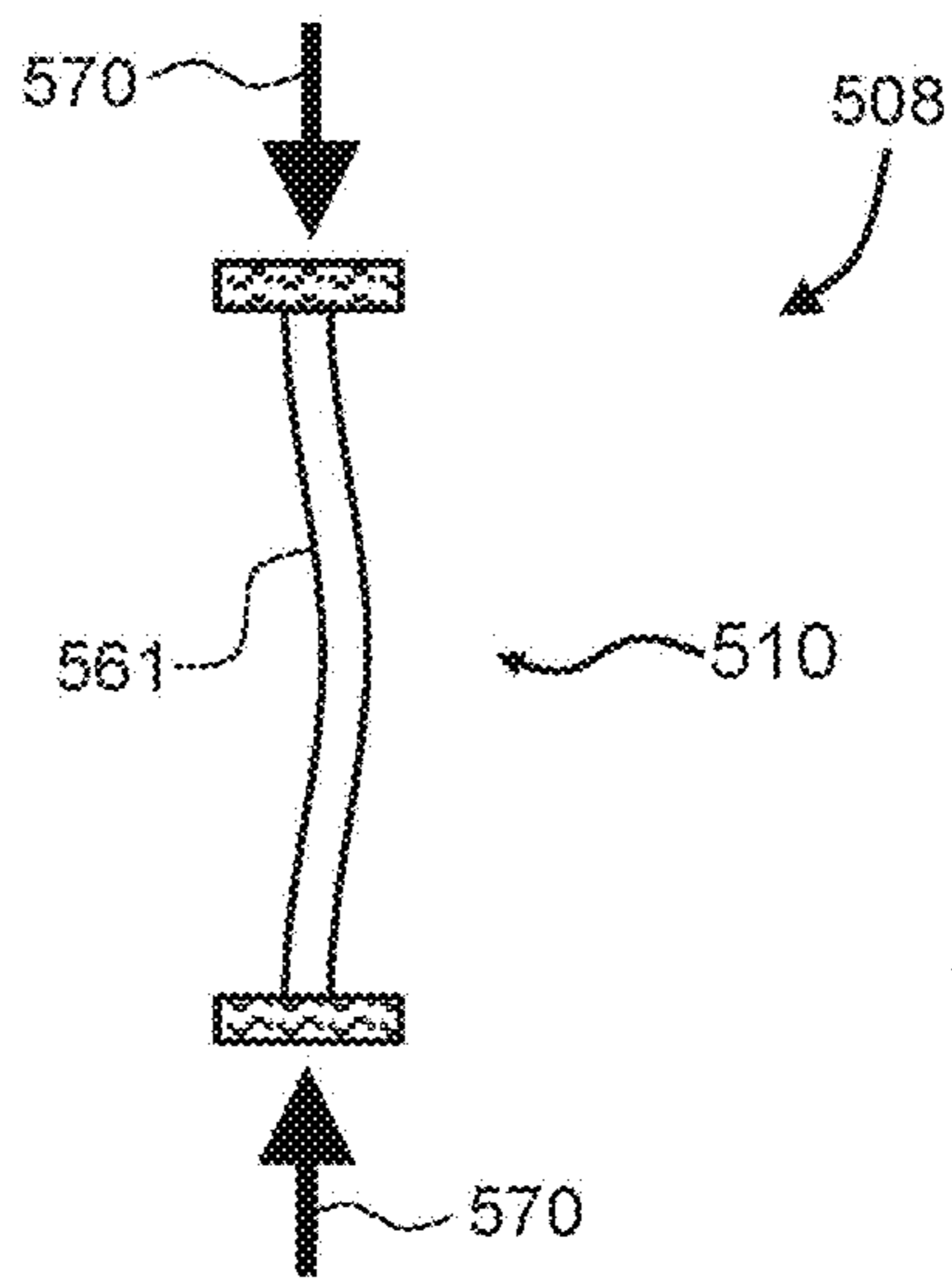
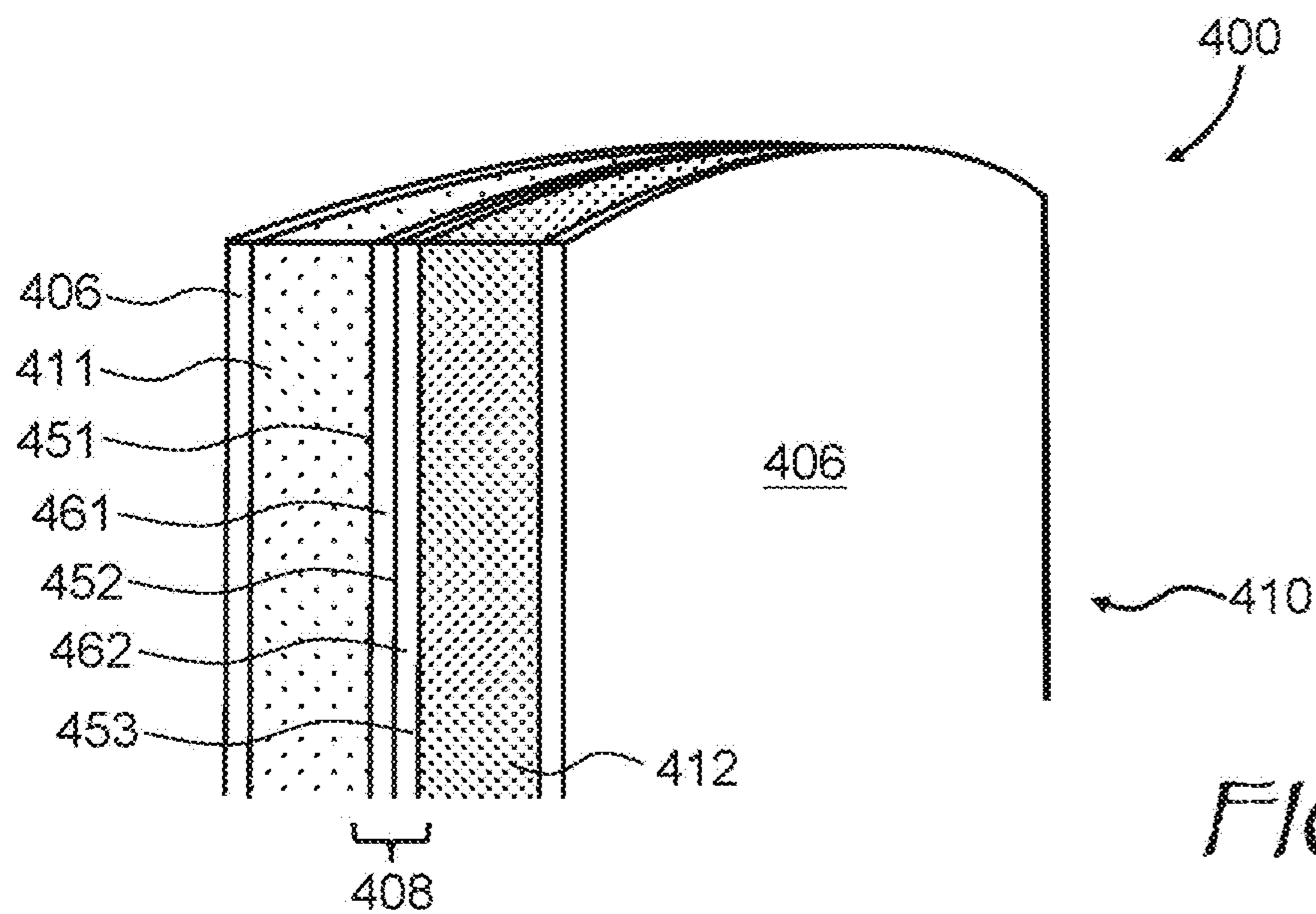

FIG. 3B



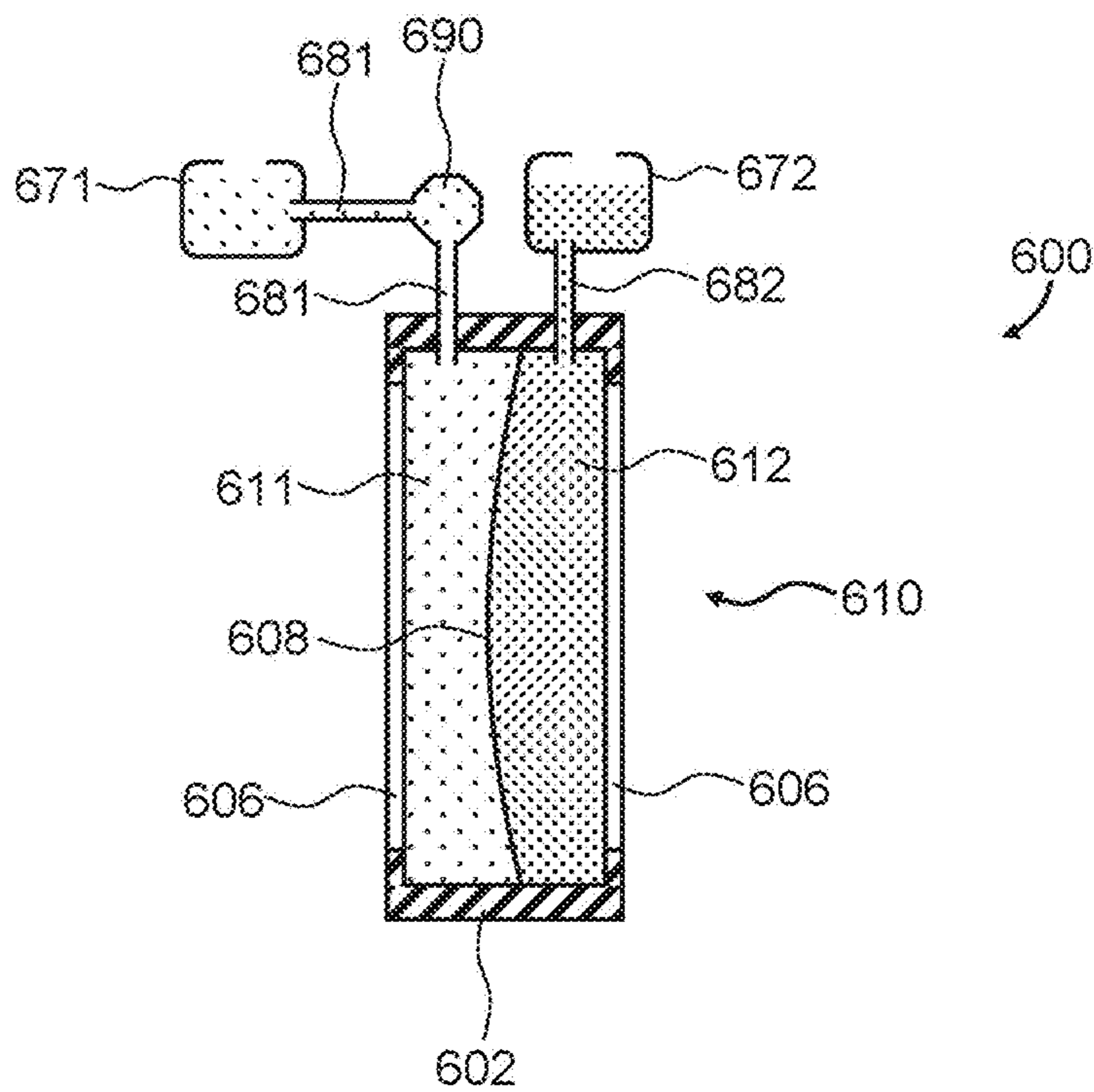

FIG. 6

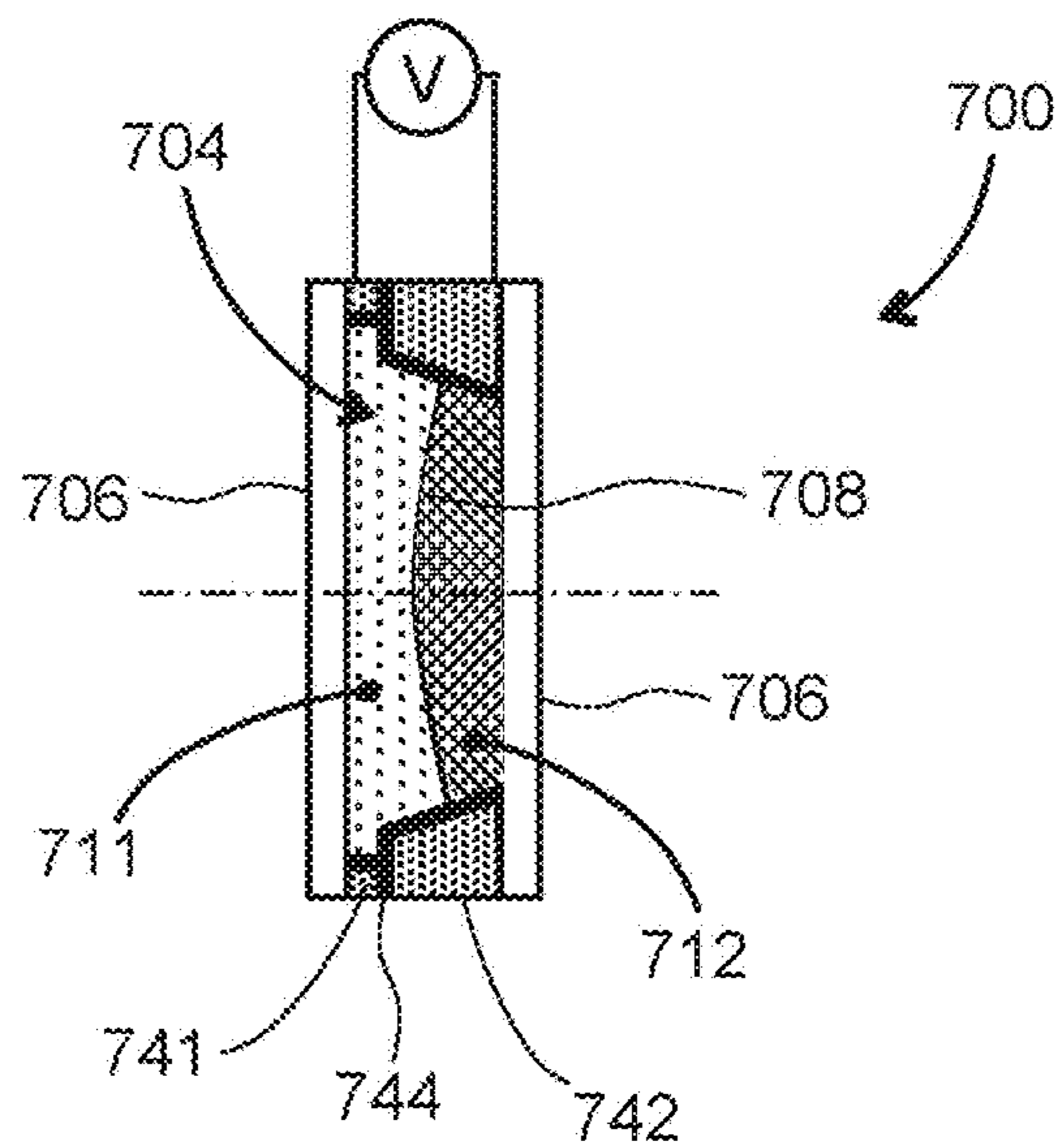

FIG. 7

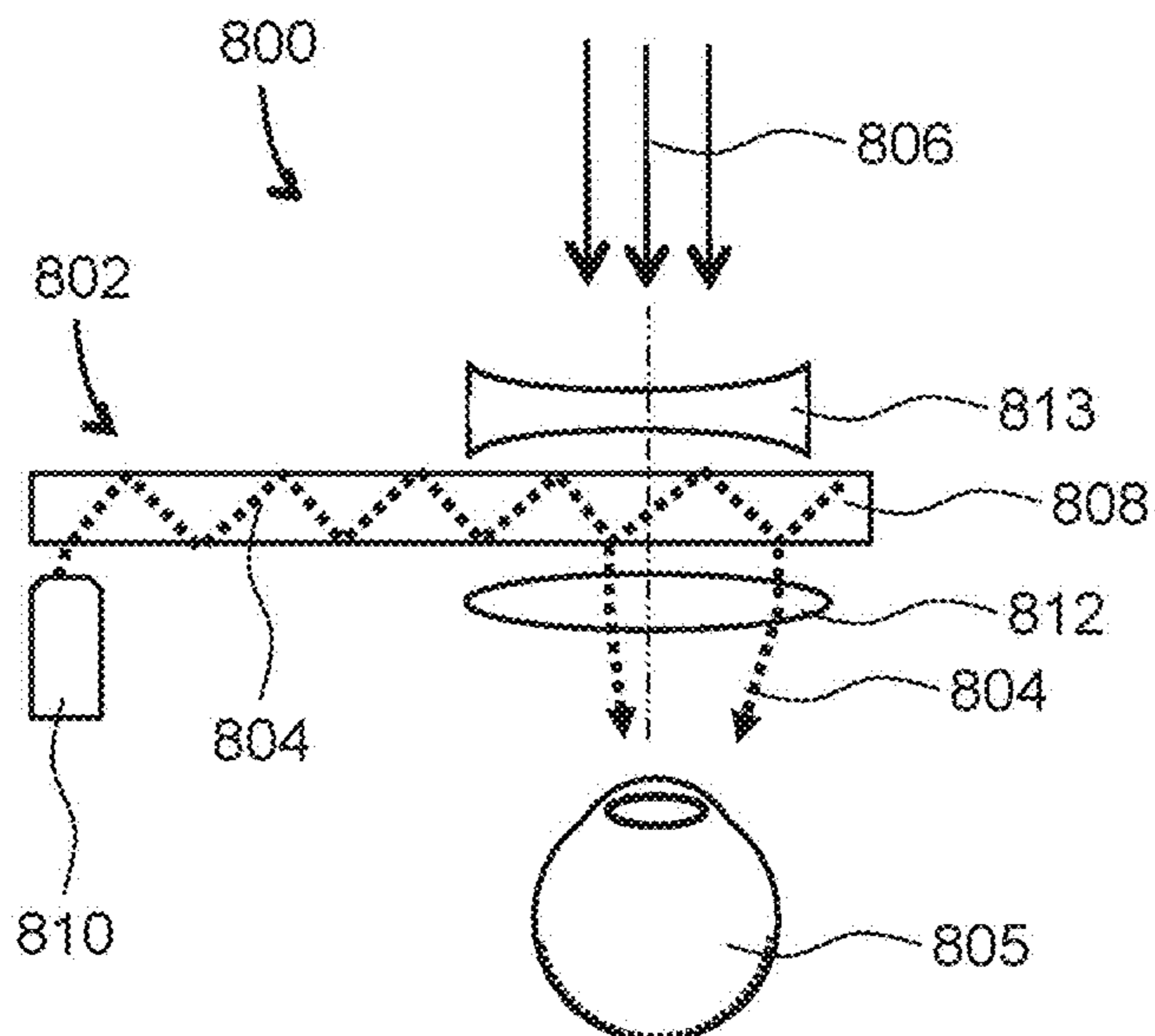

FIG. 8

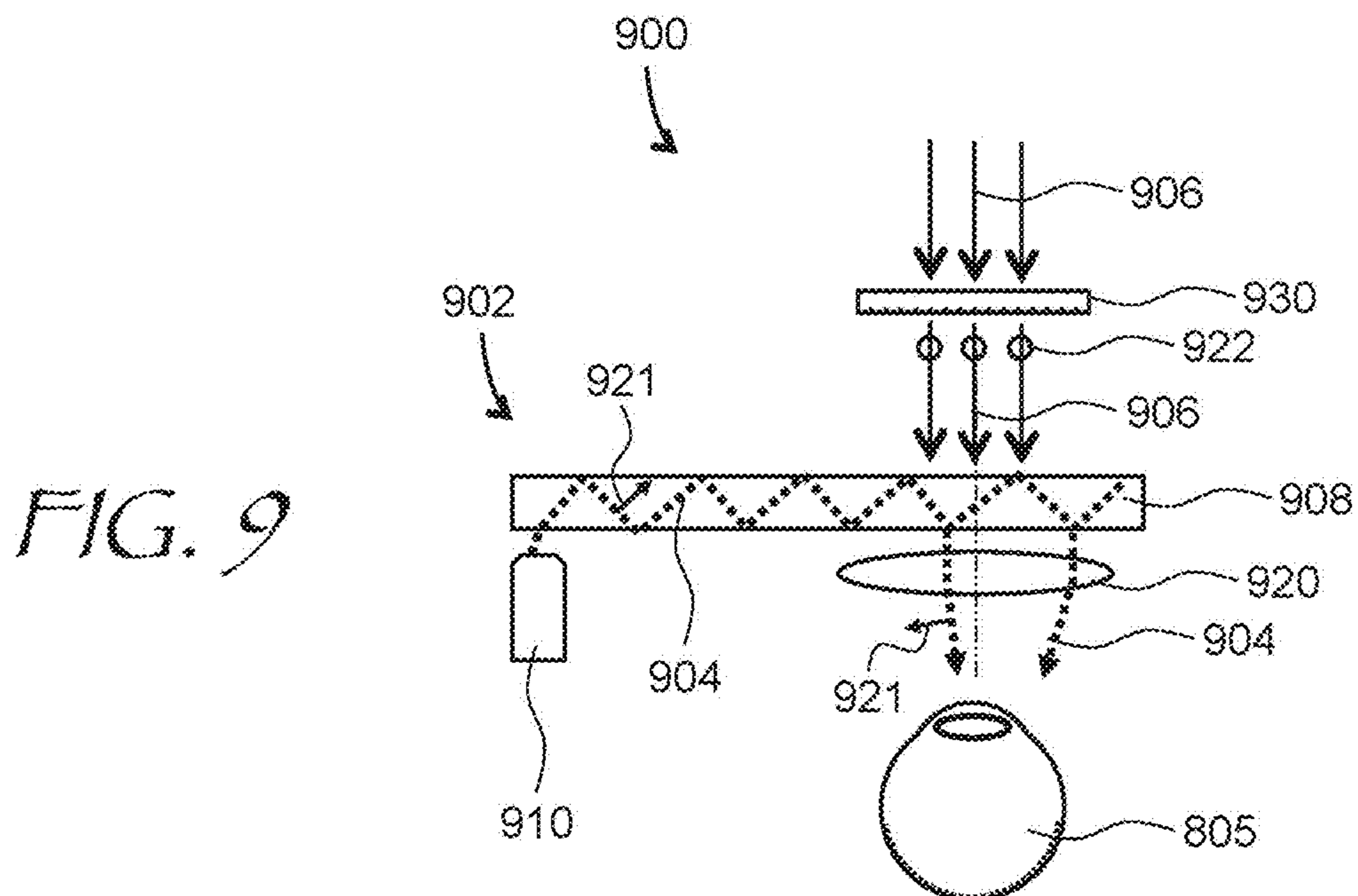

FIG. 9

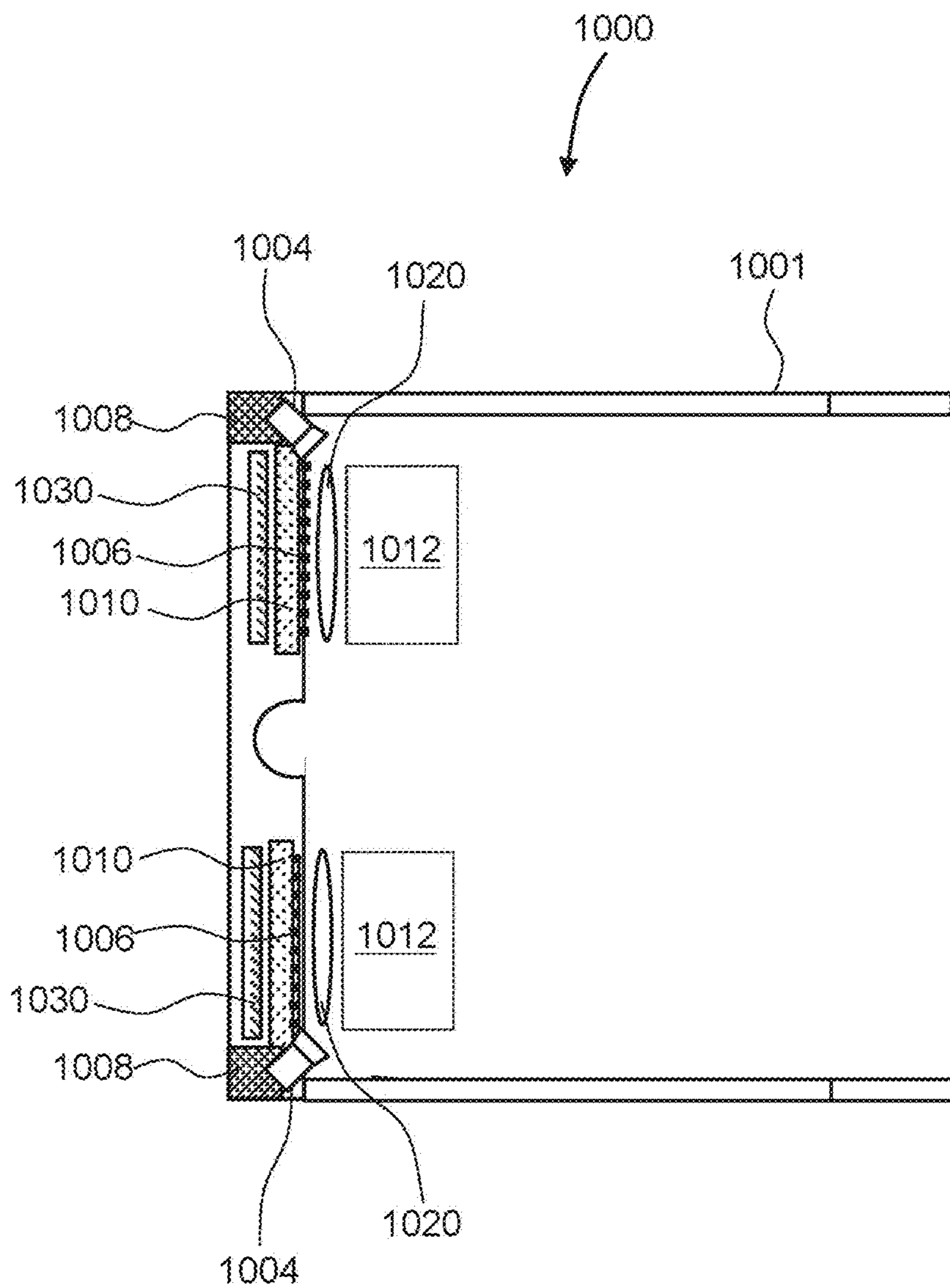

FIG. 10



## POLARIZATION-SELECTIVE VARIFOCAL LIQUID LENS

### CROSS-REFERENCE TO RELATED APPLICATION

[0001] This application is a Divisional of U.S. application Ser. No. 17/231,824 filed on 15 Apr. 2021, the disclosure of which is incorporated, in its entirety, by this reference.

### TECHNICAL FIELD

[0002] The present disclosure relates to optical devices, and in particular to varifocal lenses usable e.g. in visual display systems.

### BACKGROUND

[0003] Visual displays provide information to viewer(s) including still images, video, data, etc. Visual displays have applications in diverse fields including entertainment, education, engineering, science, professional training, advertising, to name just a few examples. Some visual displays, such as TV sets, display images to several users, and some visual display systems are intended for individual users.

[0004] An artificial reality system generally includes a near-eye display (e.g., a headset or a pair of glasses) configured to present content to an individual user. The near-eye display may display virtual objects or combine images of real objects with virtual objects, as in virtual reality (VR), augmented reality (AR), or mixed reality (MR) applications. For example, in an AR system, a user may view both images of virtual objects (e.g., computer-generated images (CGIs)) and the surrounding environment by seeing through a “combiner” component. The combiner of a wearable display is typically transparent to external light but includes some light routing optic to direct the display light into the user’s field of view.

[0005] Compact display devices are desired for head-mounted displays. Because a display of HMD or NED is usually worn on the head of a user, a large, bulky, unbalanced, and/or heavy display device would be cumbersome and may be uncomfortable for the user to wear. Compact display devices require compact and efficient light sources, image projectors, lightguides, focusing and redirecting optics, and so on.

### BRIEF DESCRIPTION OF THE DRAWINGS

[0006] Exemplary embodiments will now be described in conjunction with the drawings, in which:

[0007] FIG. 1A is a side cross-sectional view of a polarization-selective varifocal liquid lens of this disclosure;

[0008] FIG. 1B is a frontal view of the polarization-selective varifocal liquid lens of FIG. 1A;

[0009] FIG. 2A is a schematic view showing light propagation through the lens of FIGS. 1A and 1B at a first polarization;

[0010] FIG. 2B is a schematic view showing light propagation through the lens of FIGS. 1A and 1B at a second polarization orthogonal to the first polarization;

[0011] FIG. 3A is side cross-sectional view of a polarization-selective varifocal liquid lens of this disclosure including two surfaces of variable curvature, where the outside fluid is birefringent and the inside fluid is isotropic;

[0012] FIG. 3B is side cross-sectional view of a polarization-selective varifocal liquid lens of this disclosure includ-

ing two surfaces of variable curvature, where the outside fluid is isotropic and the inside fluid is birefringent;

[0013] FIG. 4 is a three-dimensional sectional view of a polarization-selective varifocal liquid lens embodiment including an elastic membrane comprising an electrically responsive polymer layer;

[0014] FIG. 5 is a side cross-sectional view of a membrane of a varifocal liquid lens of this disclosure changing its radius of curvature by application of mechanical force to a perimeter of the membrane;

[0015] FIG. 6 is a side cross-sectional view of a polarization-selective varifocal liquid lens of this disclosure with fluid volume changing actuation;

[0016] FIG. 7 is a side cross-sectional view of a polarization-selective varifocal liquid lens of this disclosure with electro-wetting actuation;

[0017] FIG. 8 is a top schematic view of a near-eye display with a pair of varifocal lenses, one upstream and one downstream of a waveguide of the display;

[0018] FIG. 9 is a top schematic view of a near-eye display with a varifocal polarization-selective liquid lens downstream of a waveguide of the display; and

[0019] FIG. 10 is a view of an augmented reality (AR) display of this disclosure having a form factor of a pair of eyeglasses.

### DETAILED DESCRIPTION

[0020] While the present teachings are described in conjunction with various embodiments and examples, it is not intended that the present teachings be limited to such embodiments. On the contrary, the present teachings encompass various alternatives and equivalents, as will be appreciated by those of skill in the art. All statements herein reciting principles, aspects, and embodiments of this disclosure, as well as specific examples thereof, are intended to encompass both structural and functional equivalents thereof. Additionally, it is intended that such equivalents include both currently known equivalents as well as equivalents developed in the future, i.e., any elements developed that perform the same function, regardless of structure.

[0021] As used herein, the terms “first”, “second”, and so forth are not intended to imply sequential ordering, but rather are intended to distinguish one element from another, unless explicitly stated. Similarly, sequential ordering of method steps does not imply a sequential order of their execution, unless explicitly stated.

[0022] In an AR near-eye display, artificially created imagery is superimposed onto a view of outside environment, augmenting the outside view with artificial objects, indicators, information, etc. Such a display may have a combiner element that combines outside light with image light generated by the display. The combiner element is placed in front of user’s eye. The combiner element may include, for example, a pupil-replicating waveguide that guides the image light within a transparent or translucent plate placed in front of the user’s eye, out-coupling portions of the image light at different locations of the waveguide towards the user’s eye. Since the waveguide plate is transparent or translucent, outside world may be observed simultaneously with viewing the artificially generated imagery.

[0023] Some AR display configurations use variable focusing of the image light to properly display objects in 3D space. To that end, a varifocal lens may be placed between the waveguide of a translucent display and the eye viewing

the image generated by the display. This creates a problem for viewing outside world, because the varifocal lens is placed in the common optical path of the image light and the outside light, and varying the focus by the varifocal lens will affect the outside world view. To overcome this deleterious effect, a “counter-lens” may be placed in an optical path of the outside light upstream of the translucent display. Optical power i.e. focusing/defocusing power of the counter-lens may be adjusted to be equal with opposite sign to the optical power of the varifocal lens to cancel its focusing power, thereby keeping the views of the outside world in proper focus. This solution is not optimal because it requires a varifocal counter-lens (i.e. an extra varifocal lens) that needs to be operated in perfect synchronism to the varifocal ocular-side lens. Any time lag between operation of these two lenses will momentarily bring the view of outside world out of focus.

**[0024]** In accordance with the present disclosure, optical paths of the outside light and the image light may be isolated from one another by polarization. The combiner element may be made to operate in a single polarization of light while being substantially transparent in the other, orthogonal polarization. The outside light is polarized at the orthogonal polarization. The varifocal ocular lens may also be made polarization-selective, so as not to impact the outside light at the orthogonal polarization, obviating the need for a counter-lens upstream of the translucent display or combiner element. A liquid lens of this disclosure is a varifocal polarization-selective lens. This lens can be used in AR displays, or in any other suitable devices and applications.

**[0025]** In accordance with the present disclosure, there is provided a varifocal liquid lens comprising a body filled with first and second fluids separated by a first interface, the first interface having a variable curvature across a clear aperture of the varifocal liquid lens. At least one of the first or second fluids is birefringent, such that a refractive index difference between the first and second fluids and resulting optical power of the varifocal liquid lens is polarization-dependent. By way of a non-limiting example, at a first polarization of light propagating through the clear aperture, the first and second fluids may be matched in refractive index, while at a second, orthogonal polarization, the first and second fluids may be mismatched in refractive index, such that the first interface between the first and second fluids has a variable, non-zero optical power for the second polarization of light while having a substantially non-variable, zero optical power for the first polarization of light. The first and second fluids may be separated by a second interface; the second interface may be coaxial with the first interface and may also have a variable curvature across the clear aperture. The second fluid may be birefringent and may surround the first fluid, which may be isotropic, or vice versa. In some embodiments, the second fluid may include a polymer-stabilized liquid crystal (LC) and/or an LC elastomer, for example.

**[0026]** In embodiments where the first interface comprises an elastic membrane, the latter may include an electrically responsive polymer layer for changing a radius of curvature of the elastic membrane by applying an electric field to the electrically responsive polymer layer. The elastic membrane may also be configured to change its radius of curvature by application of mechanical force to a perimeter of the elastic membrane. In embodiments where the first and second fluids

are immiscible, the first interface may include a boundary between the immiscible first and second fluids.

**[0027]** In accordance with the present disclosure, there is provided a varifocal liquid lens comprising first and second liquid lens components having an interface between them. The interface extends across a clear aperture of the varifocal liquid lens and had a curvature variable within a curvature range by applying a control signal. The first and second liquid lens components comprise first and second fluids, respectively. At least one of the first or second fluids is birefringent, such that: for a first light beam having a first polarization state, the first and second liquid lens components are index-matched, whereby the interface has a substantially zero optical power for the first light beam at any curvature of the interface within the curvature range; and for a second light beam having a second polarization state orthogonal to the first polarization state, the first and second liquid lens components are index-mismatched, whereby the interface has a substantially non-zero optical power for the second light beam, the non-zero optical power depending on the curvature of the interface within the curvature range.

**[0028]** In some embodiments, the first fluid is isotropic and has a first refractive index, and the second fluid is anisotropic and has an ordinary refractive index and an extraordinary refractive index. The ordinary refractive index of the second fluid may be matched to the first refractive index e.g. to within 0.05 or better. In embodiments where the interface comprises an elastic membrane, the latter may include an electrically responsive polymer layer for changing a radius of curvature of the elastic membrane by applying an electric field to the electrically responsive polymer layer. In some embodiments, elastic membrane may be configured to change its radius of curvature by application of mechanical force to a perimeter of the elastic membrane. In embodiments where the first and second fluids are immiscible, the interface may include a boundary between the immiscible first and second fluids.

**[0029]** In accordance with the present disclosure, there is further provided a near-eye display device comprising a polarization-selective display module for providing image light at a first polarization while propagating therethrough external light at a second, orthogonal polarization, the image light carrying an image to be displayed by the near-eye display device. A polarization-selective varifocal liquid lens is disposed in an optical path downstream of the polarization-selective display module, for focusing or defocusing the image light at the first polarization while propagating the external light at the second polarization substantially without focusing or defocusing. The polarization-selective varifocal liquid lens comprises a body filled with first and second fluids separated by an interface between them. The interface has a variable curvature across a clear aperture of the polarization-selective varifocal liquid lens. At least one of the first or second fluids is birefringent, such that a refractive index difference between the first and second fluids and resulting optical power of the interface is polarization-dependent. The near-eye display may further include a polarizer in an optical path upstream of the polarization-selective display module, for polarizing the external light to have the second polarization. Due to separation of the optical paths by polarization, the near-eye display may lack a varifocal lens in an optical path of the external light upstream of the polarization-selective display module. The polarization-selective display module may include a polar-

ization-selective pupil-replicating waveguide for expanding the image light at the first polarization across the clear aperture of the polarization-selective varifocal liquid lens.

[0030] Referring now to FIGS. 1A and 1B, a varifocal liquid lens 100 includes a body 102 having a pair of windows 106 mounted in a round wall 107. The cavity between the windows is filled with first 111 and second 112 fluids separated by an interface 108 between the first 111 and second 112 fluids. The interface 108 has a variable curvature across a clear aperture 110 of the varifocal liquid lens 100. The interface 108 extends across the clear aperture 110 of the varifocal liquid lens 100 and has a curvature that may be varied within a curvature range by applying some control signal such as voltage, current, pressure, etc. For example, the interface 108 may change shape between approximately spherical shapes 108A and 108B having different radii of curvature when a control signal is applied. The first 111 and second 112 fluids form respective first and second lens components having the interface 108 between them.

[0031] To provide polarization-selective performance of the lens 100, at least one of the first 111 or second 112 fluids of the lens 100 can be made optically birefringent, such that a refractive index difference between the first 111 and second 112 fluids and resulting optical power of the interface 108 of the varifocal liquid lens 100 is polarization-dependent. For instance, at a first polarization of light propagating through the clear aperture 110, the first 111 and second 112 fluids may be matched in refractive index, whereas at a second, orthogonal polarization of light propagating through the clear aperture 110, the first 111 and second 112 fluids may be mismatched in refractive index. Due to the birefringence-caused polarization-selective index matching, the interface 108 between the first 111 and second 112 fluids has a variable, non-zero optical power (i.e. focusing or defocusing power) for the second polarization of light, while having a substantially non-variable, zero optical power for the first polarization of light.

[0032] The patten point is illustrated in FIGS. 2A and 2B. For certainty, a first liquid lens component 211 may be isotropic with a refractive index  $n_1$ , and a second liquid lens component 212 may be anisotropic, i.e. birefringent, with ordinary  $n_o$  and extraordinary  $n_e$  refractive indices; in this example,  $n_1 = n_o$  to within e.g. 0.05 or better. For a first light beam 241 having a first linear polarization state 251 perpendicular to the plane of FIG. 2A, the first 211 and second 212 liquid lens components are index-matched, whereby the interface 108 between them has a substantially zero optical power for the first light beam 241 at any curvature of the interface 108 in the curvature range defined by the shapes 108A and 108B (FIG. 1A). This causes the first light beam 241 to propagate straight through the lens as it would propagate through a plano-parallel slab of a transparent material. For a second light beam 242 (FIG. 2B) having a second linear polarization state 252 orthogonal to the first linear polarization state 251, i.e. in the plane of FIG. 2B, the first 211 and second 212 liquid lens components are index-mismatched, whereby the interface 108 has a substantially non-zero optical power for the second light beam 242, causing the second light beam 242 to refract at the interface 108. The non-zero optical power depends on the curvature of the interface 108 in the curvature range defined by the shapes 108A and 108B.

[0033] In embodiments where the first and second indices of refraction are not matched for the first polarization, a

refractive index difference between the first 111 and second 112 fluids and resulting optical power of the varifocal liquid lens 100 is polarization-dependent. In such embodiments, the windows 604 may be made non-flat i.e. curved to offset a non-zero optical power of the interface 108 of the varifocal liquid lens 100 at the first polarization. The curved windows may have uniform or laterally varying thickness.

[0034] Referring to FIG. 3A, a varifocal liquid lens 300A is similar to the varifocal liquid lens 100 of FIGS. 1A and 1B. The varifocal liquid lens 300A includes a body 302 having a cavity 304 defined e.g. by a pair of windows 306 mounted in a cylindrical wall 307. The cavity 304 is filled with first 311 and second 312 fluids separated by first 331 and second 332 coaxial interfaces between the first 311 and second 312 fluids. The first 331 and second 332 coaxial interfaces have a variable radii of curvature across a clear aperture 310 of the varifocal lens 300A. In the embodiment shown in FIG. 3A, the second fluid 312 surrounds the first fluid 311. The second fluid 312 is birefringent, having an ordinary refractive index  $n_o$  for linearly polarized light with electric vector pointing perpendicular to the plane of FIG. 3A, and an extraordinary refractive index  $n_e$  for linearly polarized light with electric vector pointing parallel to the plane of FIG. 3A. The first fluid 311 is isotropic, i.e. non-birefringent, having an isotropic refractive index  $n_1$ , which may be matched to the ordinary refractive index  $n_o$  or the extraordinary refractive index  $n_e$  of the second fluid 312. Herein and throughout the rest of the specification, the term “fluid” is taken to mean a medium capable of flowing or changing shape upon application of an external force while reacting with a viscous counterforce, or a mixture of viscous and elastic counterforce, such as very viscous fluids and/or elastomers. One non-limiting example of a birefringent fluid within the meaning of this disclosure is a polymer-stabilized liquid crystal (LC). Another non-limiting example of a birefringent fluid is an LS elastomer. The first fluid 111 may be isotropic with a first isotropic refractive index, and the second fluid 112 may be an anisotropic fluid having ordinary refractive and an extraordinary refractive index. The ordinary refractive index of the second fluid may be matched to the first refractive index to e.g. within 0.1 or better, 0.05 or better, or 0.02 or better.

[0035] Turning to FIG. 3B, a varifocal liquid lens 300B is similar to the varifocal liquid lens 300A of FIG. 3A. In the varifocal liquid lens 300B of FIG. 3B, the first 311 and second 312 fluids are swapped, i.e. the second (birefringent) fluid 312 surrounds the first (isotropic) fluid 311. The principle of operation of the varifocal liquid lens 300B of FIG. 3B remains the same: for one of the two orthogonal polarizations of light, the fluids are index-matched and thus no refraction of a beam propagating through the clear aperture 310 occurs, while for the other polarization, the fluids are index-mismatched and thus variable refraction occurs causing the varifocal liquid lens 300B focus or defocus light in a controllable, variable manner.

[0036] The interface 108 (FIGS. 1A and 1B, 2A and 2B), 331 and 332 (FIGS. 3A and 3B) between the first and second fluids, or in other words the first and second liquid lens components, may include an elastic physical barrier, e.g. a transparent elastic membrane. The membrane may be made electrically responsive. Referring to FIG. 4 for example, a varifocal liquid lens 400 includes an electrically responsive transparent elastic membrane 408 separating first 411 and second 412 fluids disposed between transparent outer win-

dows 406. The body of the varifocal liquid lens 400 is not drawn for clarity. At least one of the first 411 and second 412 fluids is birefringent. The varifocal liquid lens 400 operates similarly to the lenses 100 of FIGS. 1A and 1B, 300A of FIG. 3A, and 300B of FIG. 3B. The light enters a clear aperture 410 of the varifocal liquid lens 400 and propagates through the windows 406, both fluids 411 and 412, and the electrically responsive transparent elastic membrane 408. For one of two orthogonal polarizations of the incoming light, the first 411 and second 412 fluids are index-matched. For this polarization of the incoming light, the varifocal liquid lens 400 operates as a plano-parallel transparent slab of material. For the second, orthogonal polarization of light, the first 411 and second 412 fluids are mismatched in refractive index, and accordingly, a focusing/defocusing power (optical power) of such a lens depends on the radius of curvature of the electrically responsive transparent elastic membrane 408.

[0037] The electrically responsive transparent elastic membrane 408 includes a stack of the following transparent layers: a first electrode 451, a first material 461, a second electrode 452, a second material 462, and a third electrode 453. The first 461 and/or second 462 materials may be electrostrictive materials. When an electric field is applied to the first 461 and/or second 462 materials by means of the first 451, second 452, and/or third 453 electrodes, the membrane 408 deforms, causing the optical power of the liquid lens 400 for light at the second polarization to vary.

[0038] The first 461 and/or second 462 material may include e.g. a piezoelectric material or an electrically responsive polymer, such as an electrostrictive polymer layer. The first 451 and second 452 electrodes and, for bimorph piezoelectric materials, the third electrode 453 may be, without limitation, a transparent conductive oxide such as indium tin oxide (ITO) or indium gallium zinc oxide (IGZO), or a nanowire electrode, graphene or carbon nanotube electrodes, metal electrodes, including aluminum or silver, or multilayer optical stacks of, for example, ITO and silver thin films. The electrostrictive material may be acrylate elastomer, silicone, PVDF-TrFE-CTF, and the like. Piezoelectric materials may be PVDF, PVDF-TrFE polymers, or ceramics such as PMN-PT, PZT, LiNbO<sub>3</sub> and the like. For unimorph membranes, either of the first 461 or second 462 materials may be a passive material such as polymer, glass, or ceramic, or a combination of these materials.

[0039] Referring to FIG. 5, a membrane 508 of a varifocal liquid lens of this disclosure may be driven by edge actuation. To that end, the membrane 508 may include a layer 561 of an elastic transparent material extending over a clear aperture 510. A radius of curvature of the layer 561 may be changed by applying a mechanical force, e.g. a compressive force 570 to a perimeter of the layer 561. The compressive force 570 may be applied uniformly to a perimeter of the layer 56, and may be directed to a center of the clear aperture 510. A stretching force, that is a force directed to stretch the layer 561, may also be applied, e.g. it may be applied symmetrically away from the center of the clear aperture 510.

[0040] In some embodiments, a varifocal liquid lens of this disclosure may be actuated by varying a fluid volume of the two liquid lens components. Referring to FIG. 6, a varifocal liquid lens 600 is similar to the varifocal liquid lens 100 of FIGS. 1A and 1B, and includes similar elements: a

body 602 with windows 606 defining a clear aperture 610, and first 611 and second 612 fluids separated by a flexible transparent membrane 608 which, together with the windows 606, forms two adjacent liquid lens components of a compound liquid lens. A volume of the first fluid 611 may be varied by means of a pump 690 in fluid communication with a first fluid reservoir 671 by means of a first tube 681. When the volume of the first fluid 611 is increased by pumping the first fluid 611 from the first fluid reservoir 671, the flexible transparent membrane 608 expands to the left in FIG. 6, reducing its radius of curvature and pushing the second fluid 612 out via the second tube 682 into a second fluid reservoir 672. When the volume of the first fluid 611 is decreased, the radius of curvature of the flexible transparent membrane 608 is decreased. At least one of the first 611 or second 612 fluids of the varifocal liquid lens 600 is optically birefringent, such that a refractive index difference between the first 611 and second 612 fluids and resulting optical power of the varifocal liquid lens 600 is polarization-dependent. At a first polarization of light propagating through the clear aperture 610, the first 611 and second 612 fluids may be matched in refractive index, whereas at a second, orthogonal polarization of light propagating through the clear aperture 610, the first 611 and second 612 fluids may be mismatched in refractive index. Due to the polarization-dependent refractive index step in going from the first 611 to the second 611 fluid, the varifocal liquid lens 600 has a variable, non-zero optical for the second polarization of light, while having a substantially non-variable, zero optical power for the first polarization of light. More generally, the refractive index difference between the first 611 and second 612 fluids and resulting optical power of the varifocal liquid lens 600 may be polarization-dependent due to the birefringence of at least one of the first 611 or second 612 fluids, and an optical power resulting from refractive index mismatch between the first 611 and second 612 fluids at one of the two orthogonal polarizations may be offset by a curved shape of at least one of the windows 606.

[0041] In configurations where the first and second fluids are immiscible, the interface may include a boundary between immiscible fluids, or in other words, the interface may be simply an inter-fluid boundary formed by surface tension at the boundary. In such lenses, the interface curvature may be controlled with the use of a phenomenon known as electrowetting. Referring to FIG. 7 as a non-limiting illustration, a varifocal liquid lens 700 includes a cavity 704 formed by first 741 and second 742 circular electrodes and a pair of windows 706. The cavity 704 includes first 711 and second 712 immiscible fluids having different indices of refraction at one polarization of impinging light and a substantially same index of refraction (e.g. less than 0.05 refractive index difference) at a second, orthogonal polarization of the impinging light. To that end, at least one of the first 711 or second 712 fluids may be birefringent. The first 711 and second 712 fluids are separated by an inter-fluid boundary 708. The first 741 and second 742 circular electrodes are electrically insulated from each other by an insulation layer 744 spanning between the first 741 and second 742 circular electrodes and shown in FIG. 7 with a thick black line. In operation, when a voltage V is applied between the first 741 and second 742 electrodes, a radius of curvature of the inter-fluid boundary 708 changes due to the electrowetting effect. Since the first 711 and second 712 fluids have different refractive indices for one of the two

orthogonal polarizations of incoming light, a change of the radius of curvature of the inter-fluid boundary **708** results in a variation of optical power of the varifocal liquid lens **700**. The windows **706** may be flat as shown, or at least one of the windows **706** may be curved e.g. concave or convex to compensate a slight index mismatch between the two fluids **711** and **712**. In some embodiments, a flexible transparent membrane may be provided for a liquid lens for separating two media having different refractive indices.

[0042] Referring to FIG. 8, a near-eye display device **800** includes a display module **802** for providing image light **804** to a user's eye **805** while propagating external light **806** through a pupil-replicating waveguide **808** of the display module **802**. The image light **804** carries an image to be displayed by the near-eye display device **800** to the user. The display module **802** may include a projector **810** for generating the image light **804**, which is coupled to the pupil-replicating waveguide **808**. Such a configuration enables the generated imagery to be superimposed with the outside world view. A varifocal lens **812** is provided between the pupil-replicating waveguide **808** and the eye **805**, for variably focusing the image light **804**. A counter-lens **813** needs to be provided upstream of the pupil-replicating waveguide **808** for counter-acting in real time, the focusing of the external light **806** by the varifocal lens **812**. This adds to weight and complexity of the near-eye display device **800**.

[0043] Turning now to FIG. 9, a near-eye display device **900** includes a polarization-selective display module **902** for providing image light **904** at a first polarization **921** while propagating through the polarization-selective display module **902** external light **904** at a second, orthogonal polarization **922**. In the embodiment shown, the polarization-selective display module **902** includes a projector **910** coupled to a polarization-selective pupil-replicating waveguide **908**. The projector **910** generates image light **904** at the first polarization **921** carrying an image to be displayed by the near-eye display device **900**. The polarization-selective pupil-replicating waveguide **908** expands the image light **904** at the first polarization **921** across an eyebox of the near-eye display device **900**, while propagating through the external light **904** at the second polarization **922**. A polarization-selective varifocal liquid lens **920**, which may include any of the polarization-selective liquid lenses disclosed herein, is disposed in an optical path downstream of the polarization-selective display module **902**, for focusing or defocusing the image light **604** at the first polarization **921** while propagating the external light **906** at the second polarization **922** substantially without focusing or defocusing.

[0044] A polarizer **930** may be provided in an optical path upstream of the polarization-selective display module **902**, i.e. upstream of the polarization-selective pupil-replicating waveguide **908**, for polarizing the external light **906** to have the second polarization **922**. Notably, the near-eye display device **900** may be absent a lens, varifocal or otherwise, in an optical path of the external light **906** upstream of the polarization-selective display module **902**, simplifying overall construction and ensuring that the outside world view is not affected by the polarization-selective varifocal liquid lens **920**, regardless of its focusing power for the image light **904** at the first polarization state **921**.

[0045] Turning to FIG. 10, an augmented reality (AR) near-eye display **1000** includes a frame **1001** having a form factor of a pair of eyeglasses. The frame **1001** supports, for

each eye: a projector **1008** for providing polarized image light, a polarization-selective pupil-replicating waveguide **1010** optically coupled to the projector **1008**, an eye-tracking camera **1004**, a plurality of illuminators **1006**, and a polarization-selective varifocal lens **1020** disclosed herein. The illuminators **1006** may be supported by the polarization-selective pupil-replicating waveguide **1010** for illuminating an eyebox **1012**. The projector **1008** provides a fan of polarized light beams carrying an image in angular domain to be projected into a user's eye at the eyebox **1012**. The polarization-selective pupil-replicating waveguide **1010** receives the fan of polarized light beams and provides multiple laterally offset parallel copies of each beam of the fan of polarized light beams, thereby extending the projected image over the eyebox **1012**.

[0046] Multi-emitter laser sources may be used in the projector **1008**. Each emitter of the multi-emitter laser chip may be configured to emit image light at an emission wavelength of a same color channel. The emission wavelengths of different emitters of the same multi-emitter laser chip may occupy a spectral band having the spectral width of the laser source.

[0047] In some embodiments, the projector **1008** may include two or more multi-emitter laser chips emitting light at wavelengths of a same color channel or different color channels. For AR applications, the polarization-selective pupil-replicating waveguide **1010** can be transparent or translucent for light at the other, orthogonal polarization, to enable the user to view the outside world together with the images projected into each eye and superimposed with the outside world view. The images projected into each eye may include objects disposed with a simulated parallax, so as to appear immersed into the real world view. The polarization-selective varifocal lenses **1020** may be used to focus or defocus the image light substantially without impacting the view of outside environment. To that end, polarizers **1030** may be provided in front of the polarization-selective pupil-replicating waveguides **1010** that polarize outside light at the polarization orthogonal to the polarization of the image light. For example, both polarizations can be linear orthogonal polarizations.

[0048] The purpose of the eye-tracking cameras **1004** is to determine position and/or orientation of both eyes of the user. Once the position and orientation of the user's eyes are known, a gaze convergence distance and direction may be determined. The imagery displayed by the projectors **1008** may be adjusted dynamically to account for the user's gaze, for a better fidelity of immersion of the user into the displayed augmented reality scenery, and/or to provide specific functions of interaction with the augmented reality. In operation, the illuminators **1006** illuminate the eyes at the corresponding eyeboxes **1012**, to enable the eye-tracking cameras to obtain the images of the eyes, as well as to provide reference reflections i.e. glints. The glints may function as reference points in the captured eye image, facilitating the eye gazing direction determination by determining position of the eye pupil images relative to the glints images. To avoid distracting the user with illuminating light, the latter may be made invisible to the user. For example, infrared light may be used to illuminate the eyeboxes **1012**.

[0049] Embodiments of the present disclosure may include, or be implemented in conjunction with, an artificial reality system. An artificial reality system adjusts sensory information about outside world obtained through the senses

such as visual information, audio, touch (somatosensation) information, acceleration, balance, etc., in some manner before presentation to a user. By way of non-limiting examples, artificial reality may include virtual reality (VR), augmented reality (AR), mixed reality (MR), hybrid reality, or some combination and/or derivatives thereof. Artificial reality content may include entirely generated content or generated content combined with captured (e.g., real-world) content. The artificial reality content may include video, audio, somatic or haptic feedback, or some combination thereof. Any of this content may be presented in a single channel or in multiple channels, such as in a stereo video that produces a three-dimensional effect to the viewer. Furthermore, in some embodiments, artificial reality may also be associated with applications, products, accessories, services, or some combination thereof, that are used to, for example, create content in artificial reality and/or are otherwise used in (e.g., perform activities in) artificial reality. The artificial reality system that provides the artificial reality content may be implemented on various platforms, including a wearable display such as an HMD connected to a host computer system, a standalone HMD, a near-eye display having a form factor of eyeglasses, a mobile device or computing system, or any other hardware platform capable of providing artificial reality content to one or more viewers.

**[0050]** The present disclosure is not to be limited in scope by the specific embodiments described herein. Indeed, other various embodiments and modifications, in addition to those described herein, will be apparent to those of ordinary skill in the art from the foregoing description and accompanying drawings. Thus, such other embodiments and modifications are intended to fall within the scope of the present disclosure. Further, although the present disclosure has been described herein in the context of a particular implementation in a particular environment for a particular purpose, those of ordinary skill in the art will recognize that its usefulness is not limited thereto and that the present disclosure may be beneficially implemented in any number of environments for any number of purposes. Accordingly, the claims set forth below should be construed in view of the full breadth and spirit of the present disclosure as described herein.

What is claimed is:

**1.** A varifocal liquid lens comprising first and second liquid lens components having an interface therebetween, the interface extending across a clear aperture of the varifocal liquid lens and having a curvature variable within a curvature range by applying a control signal;

wherein the first and second liquid lens components comprise first and second fluids, respectively, wherein at least one of the first or second fluids is birefringent, such that:

for a first light beam having a first polarization state, the first and second liquid lens components are index-matched, whereby the interface has a substantially zero optical power for the first light beam at any curvature of the interface within the curvature range; and

for a second light beam having a second polarization state orthogonal to the first polarization state, the first and second liquid lens components are index-mismatched,

whereby the interface has a substantially non-zero optical power for the second light beam, the non-zero optical power depending on the curvature of the interface within the curvature range.

**2.** The varifocal liquid lens of claim **1**, wherein the first fluid is isotropic and has a first refractive index, and wherein the second fluid is anisotropic and has an ordinary refractive index and an extraordinary refractive index;

wherein the ordinary refractive index of the second fluid is matched to the first refractive index to within 0.05 or better.

**3.** The varifocal liquid lens of claim **1**, wherein the interface comprises an elastic membrane.

**4.** The varifocal liquid lens of claim **3**, wherein the elastic membrane comprises an electrically responsive polymer layer for changing a radius of curvature of the elastic membrane by applying an electric field to the electrically responsive polymer layer.

**5.** The varifocal liquid lens of claim **3**, wherein the elastic membrane is configured to change its radius of curvature by application of mechanical force to a perimeter of the elastic membrane.

**6.** The varifocal liquid lens of claim **1**, wherein the first and second fluids are immiscible, and wherein the interface comprises a boundary between the immiscible first and second fluids.

**7.** A near-eye display device comprising:

a polarization-selective display module for providing image light at a first polarization while propagating therethrough external light at a second, orthogonal polarization, wherein the image light carries an image to be displayed by the near-eye display device; and

a polarization-selective varifocal liquid lens in an optical path downstream of the polarization-selective display module, for focusing or defocusing the image light at the first polarization while propagating the external light at the second polarization substantially without focusing or defocusing, the polarization-selective varifocal liquid lens comprising a body filled with first and second fluids separated by an interface therebetween, the interface having a variable curvature across a clear aperture of the polarization-selective varifocal liquid lens;

wherein at least one of the first or second fluids is birefringent, such that a refractive index difference between the first and second fluids and resulting optical power of the interface is polarization-dependent.

**8.** The near-eye display device of claim **7**, further comprising a polarizer in an optical path upstream of the polarization-selective display module, for polarizing the external light to have the second polarization.

**9.** The near-eye display device of claim **7**, absent a varifocal lens in an optical path of the external light upstream of the polarization-selective display module.

**10.** The near-eye display device of claim **7**, wherein the polarization-selective display module comprises a polarization-selective pupil-replicating waveguide for expanding the image light at the first polarization across the clear aperture of the polarization-selective varifocal liquid lens.

\* \* \* \* \*