



(19) **United States**

(12) **Patent Application Publication**
GANDY et al.

(10) **Pub. No.: US 2024/0250745 A1**

(43) **Pub. Date: Jul. 25, 2024**

(54) **PORTABLE DEPLOYABLE UNDERGROUND COMMUNICATION SYSTEMS, DEVICES AND METHODS**

(60) Provisional application No. 62/298,297, filed on Feb. 22, 2016.

(71) Applicant: **Applied Minds, LLC**, Burbank, CA (US)

(72) Inventors: **Charles L. GANDY**, Annapolis, MD (US); **Clinton Blake HOPE**, Los Angeles, CA (US); **Edward Francis ADAMS**, Los Angeles, CA (US); **Donald Gregory LARIVIERE**, Glendale, CA (US); **Houstin L. LICHTENWALNER**, Macungie, PA (US)

Publication Classification

(51) **Int. Cl.**
H04B 7/145 (2006.01)
H04B 7/155 (2006.01)
H04L 67/12 (2006.01)

(52) **U.S. Cl.**
CPC **H04B 7/145** (2013.01); **H04B 7/15507** (2013.01); **H04L 67/12** (2013.01)

(21) Appl. No.: **18/593,150**

(22) Filed: **Mar. 1, 2024**

Related U.S. Application Data

(60) Continuation of application No. 17/935,227, filed on Sep. 26, 2022, now Pat. No. 11,923,949, which is a continuation of application No. 17/139,545, filed on Dec. 31, 2020, now Pat. No. 11,456,799, which is a continuation of application No. 16/730,300, filed on Dec. 30, 2019, now Pat. No. 10,887,000, which is a division of application No. 15/877,281, filed on Jan. 22, 2018, now Pat. No. 10,554,288, which is a continuation of application No. 15/439,761, filed on Feb. 22, 2017, now Pat. No. 9,876,556.

(57) **ABSTRACT**

Disclosed are passive reflector radio communications systems, such as for UHF frequencies or greater than UHF frequencies, and related deployment systems and devices that provide underground communications. Embodiments of the system include reflector elements to provide passive radio communications, structural frameworks to support and orient the reflector elements, methods for calculating reflector size, shape, and position corresponding to a desired wavelength, and deployment methods and devices to install the communication system at a desired location. The passive reflectors can be placed in a folded or otherwise compact mode, for transport into underground tunnels. Once at the desired installation location, the system can be installed, with the reflectors positioned appropriately for the radio frequencies used at the location. Some of the embodiments include any of vertical or horizontal foldable reflector poles, reflective sheets, reflective mesh sheets and/or ropes, inflatable reflective pucks, and rapid deployment systems and methods.

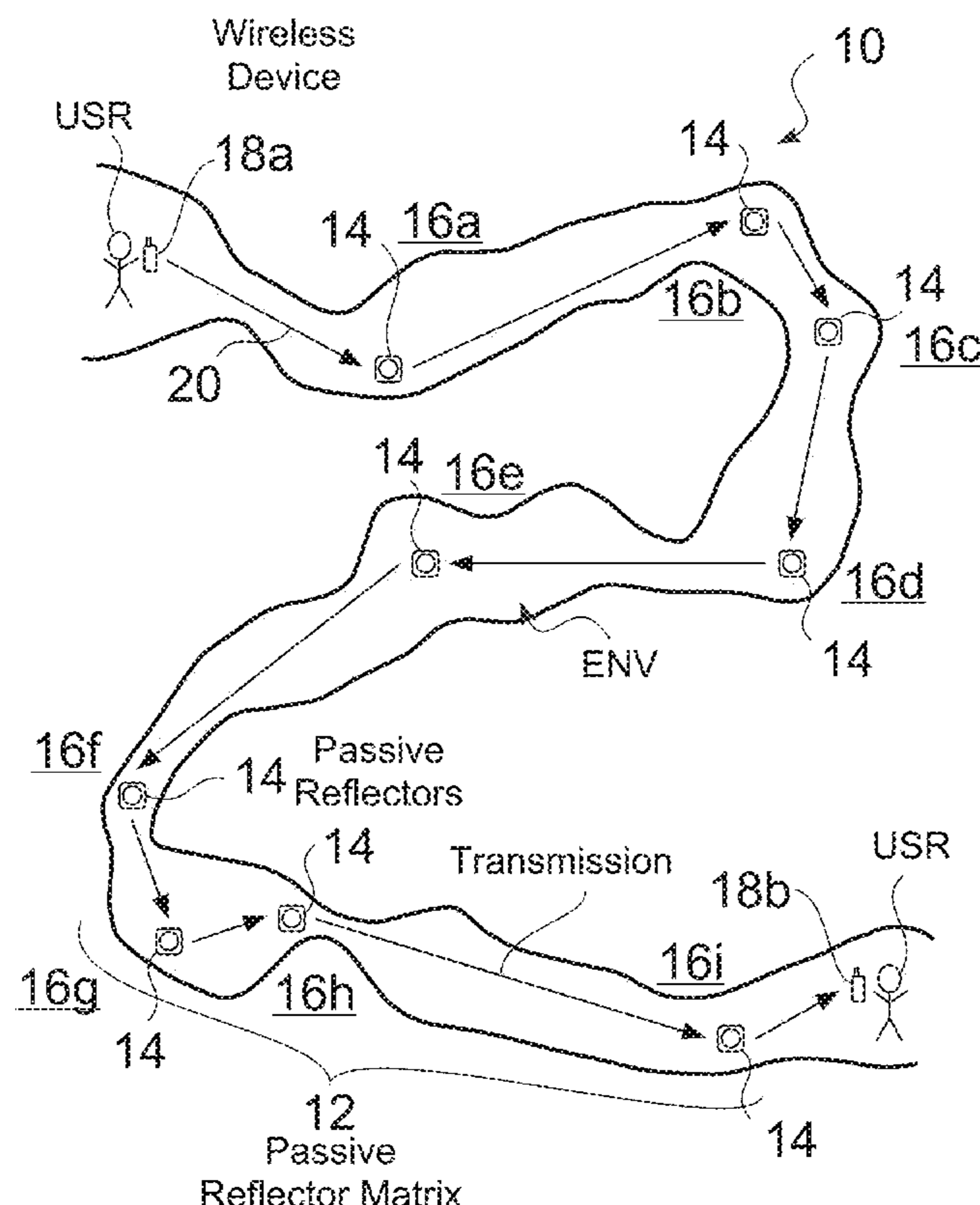

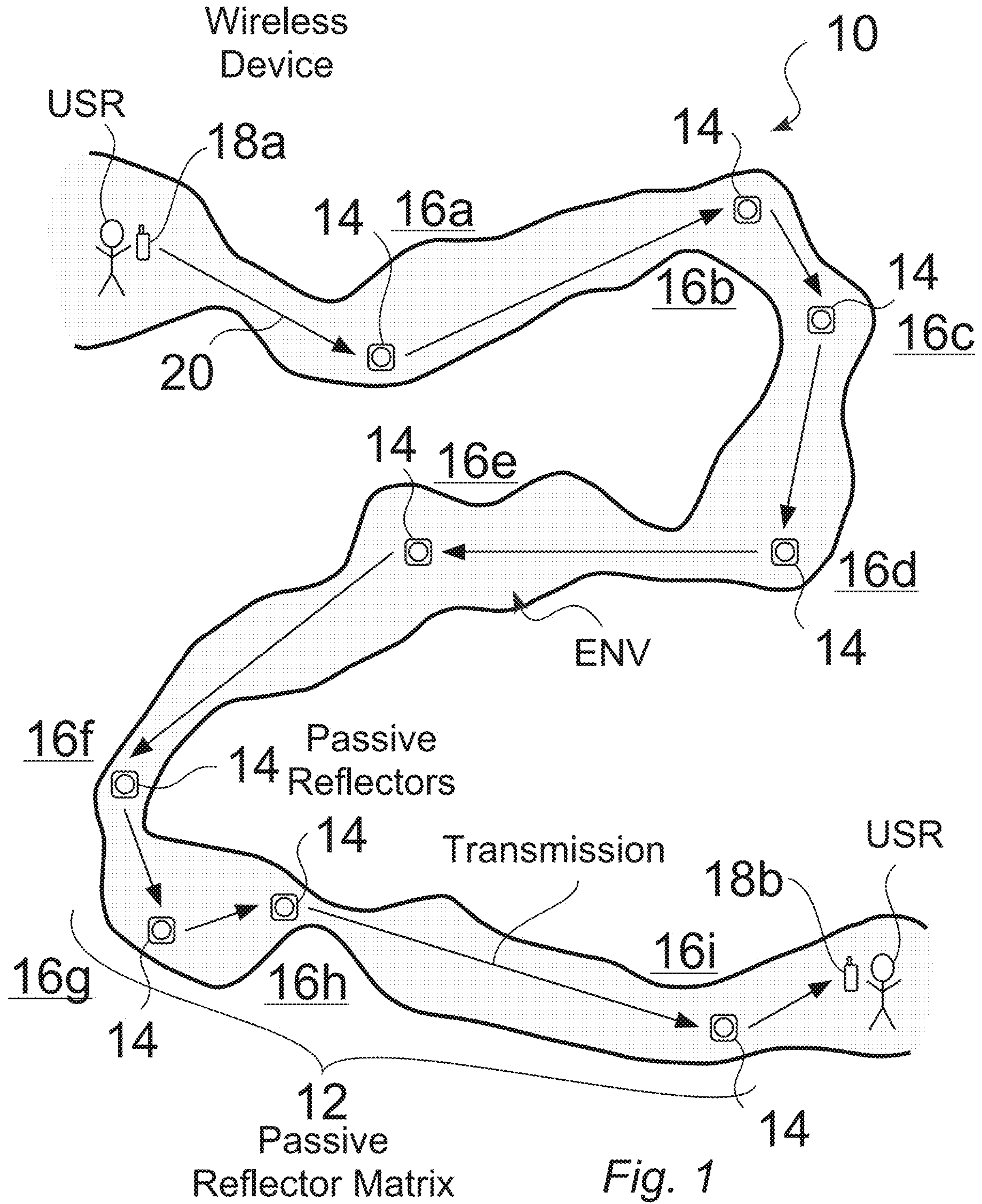

Fig. 1

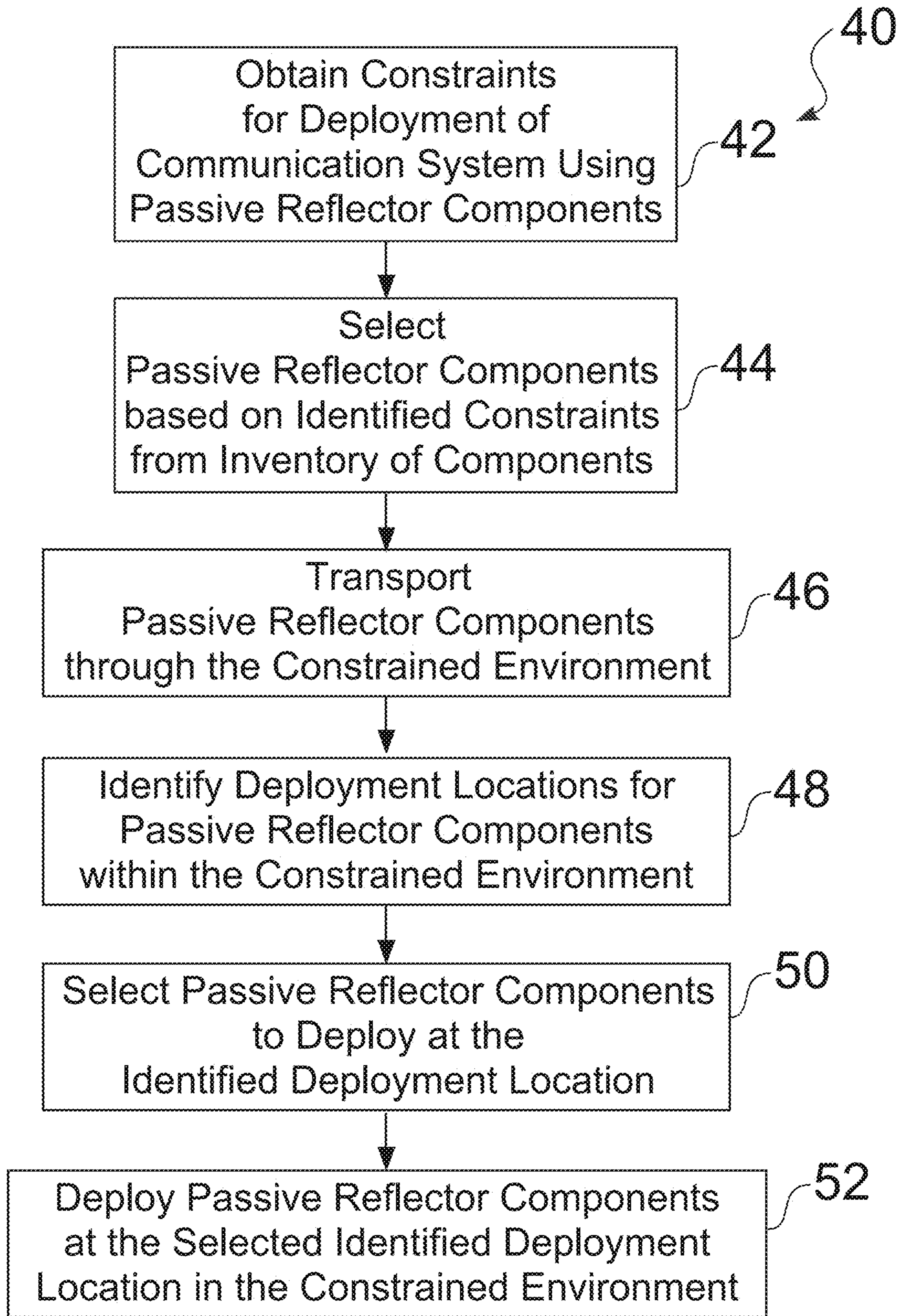

Fig. 2

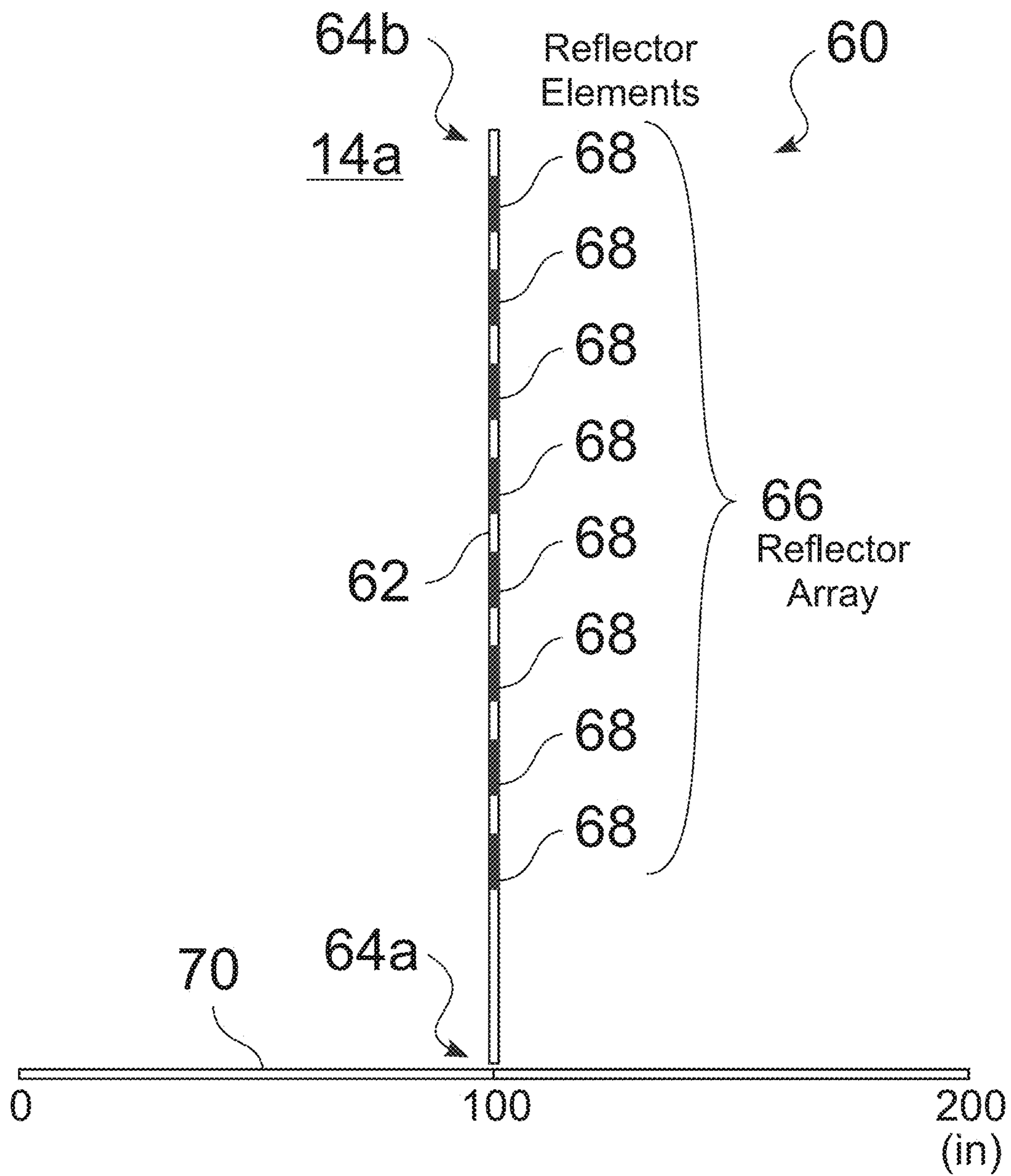

Fig. 3

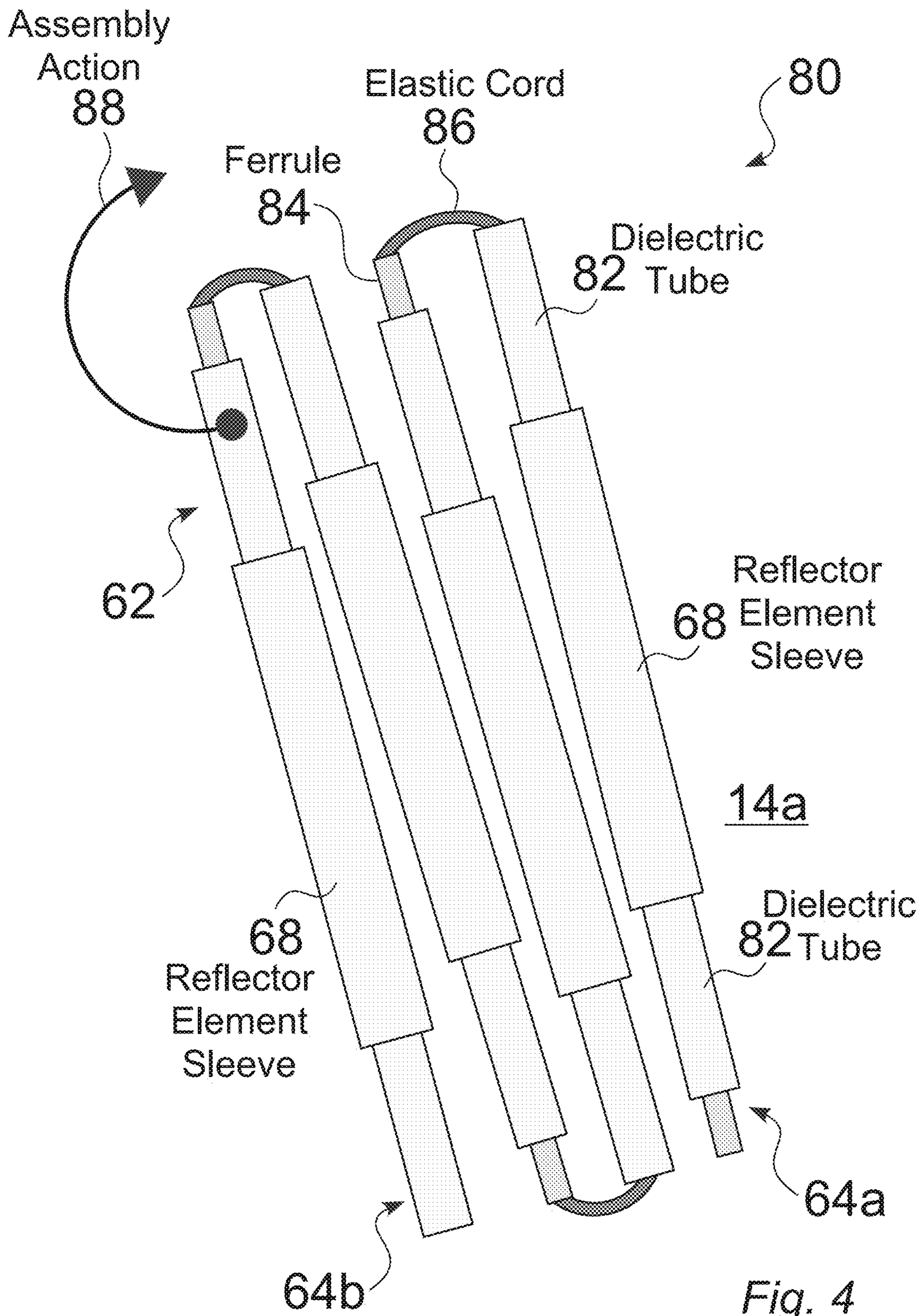

Fig. 4

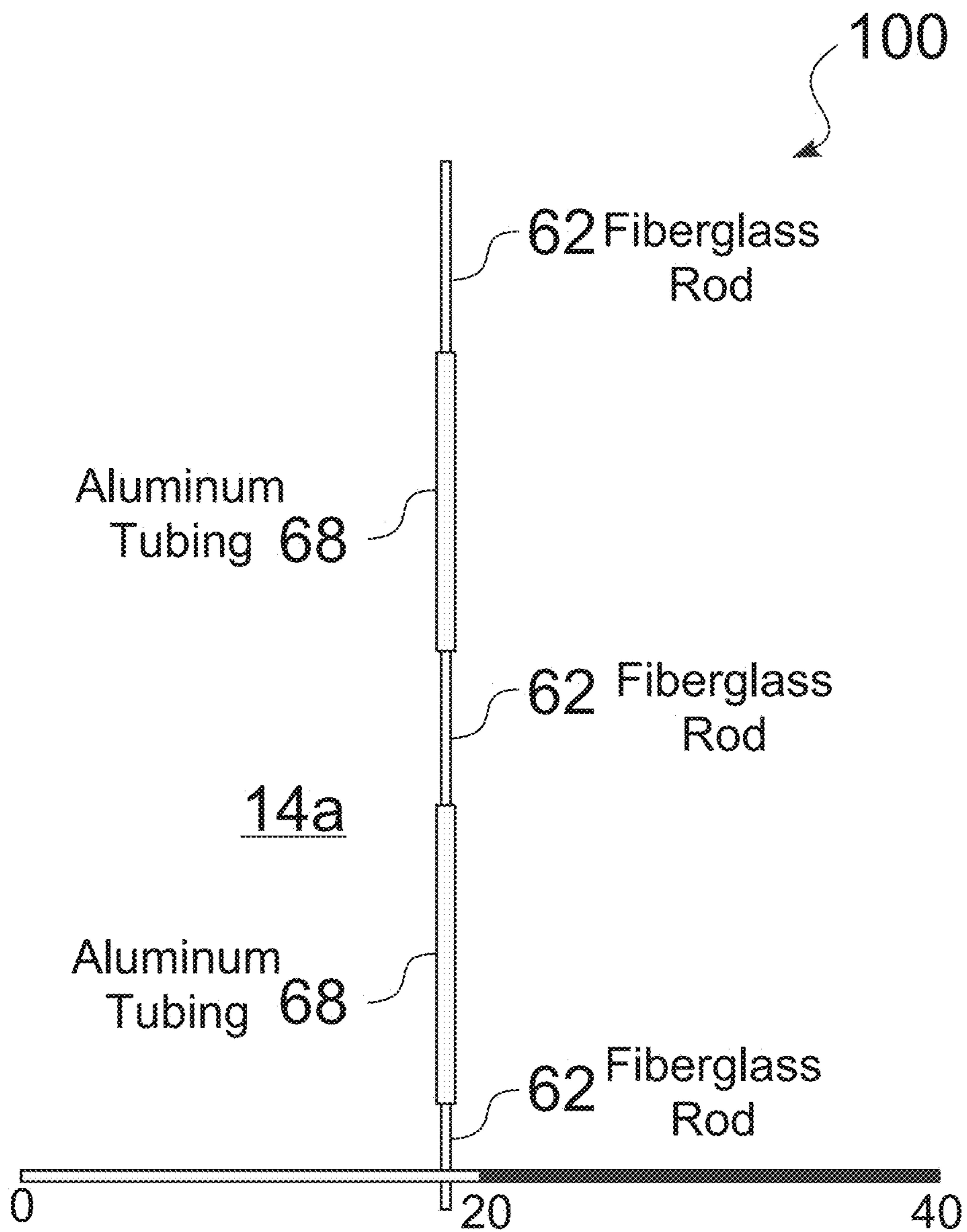

Fig. 5

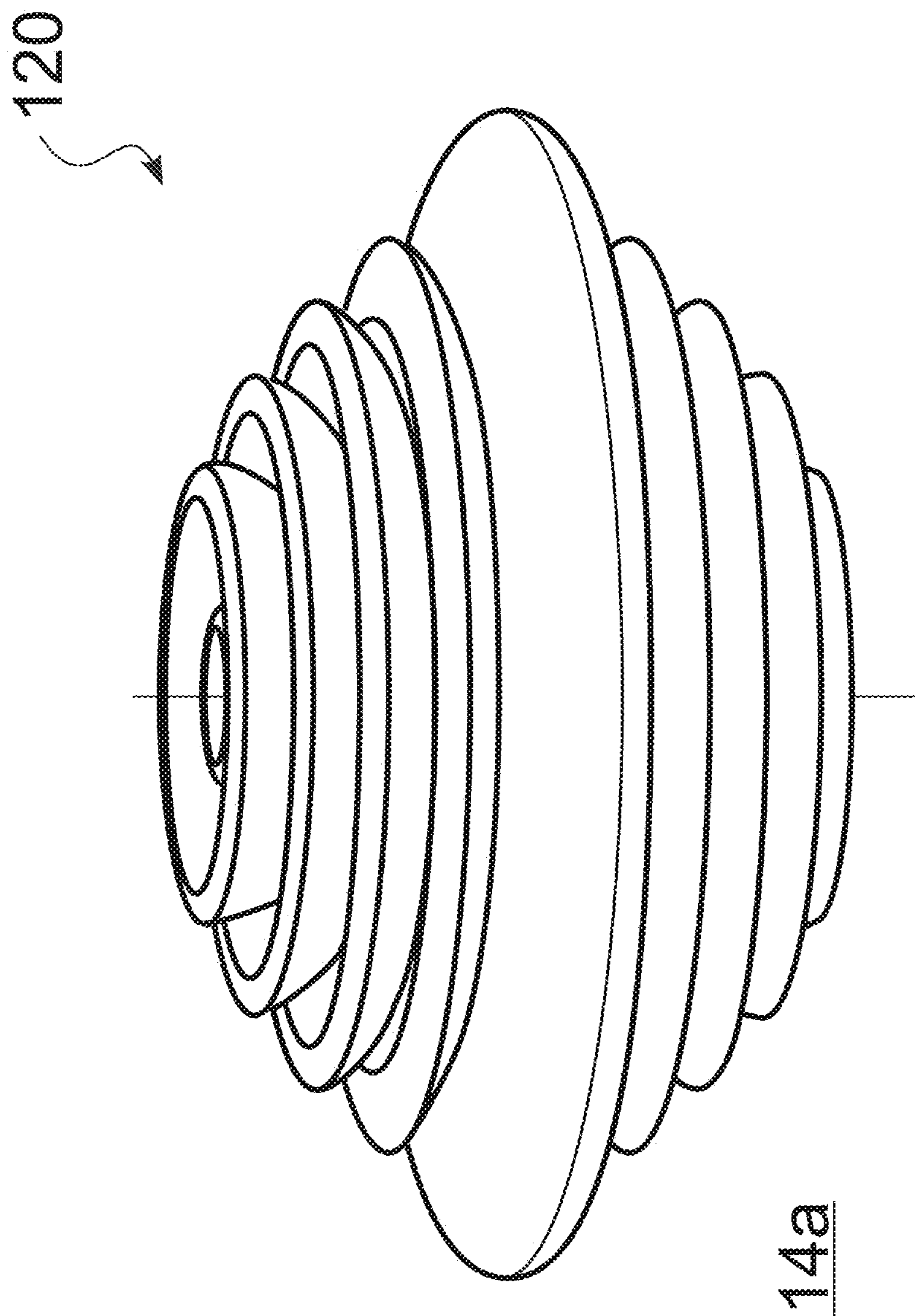
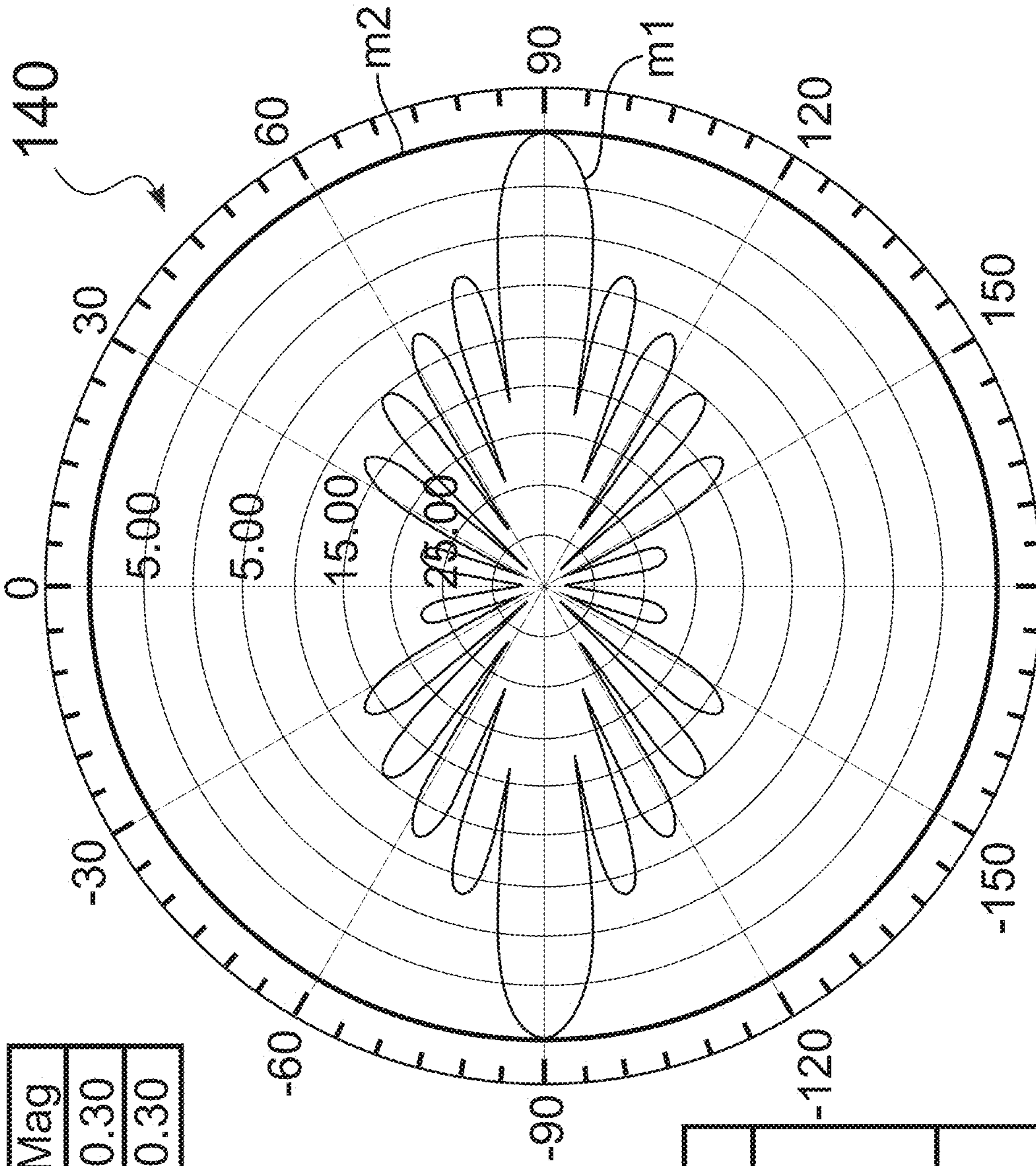

Fig. 6



Name	Theta	Phi	Ang	Mag
m1	90.00		90.00	10.30
m2		90.00	90.00	10.30

Curve Info	
—	dB (Realized Gain Total) 400MHz: Last Adaptive Freq= '0.4GHz' Phi='0deg'
—	dB (Realized Gain Total)_1 400MHz: Last Adaptive Freq= '0.4GHz' Theta='90deg'

Fig. 7

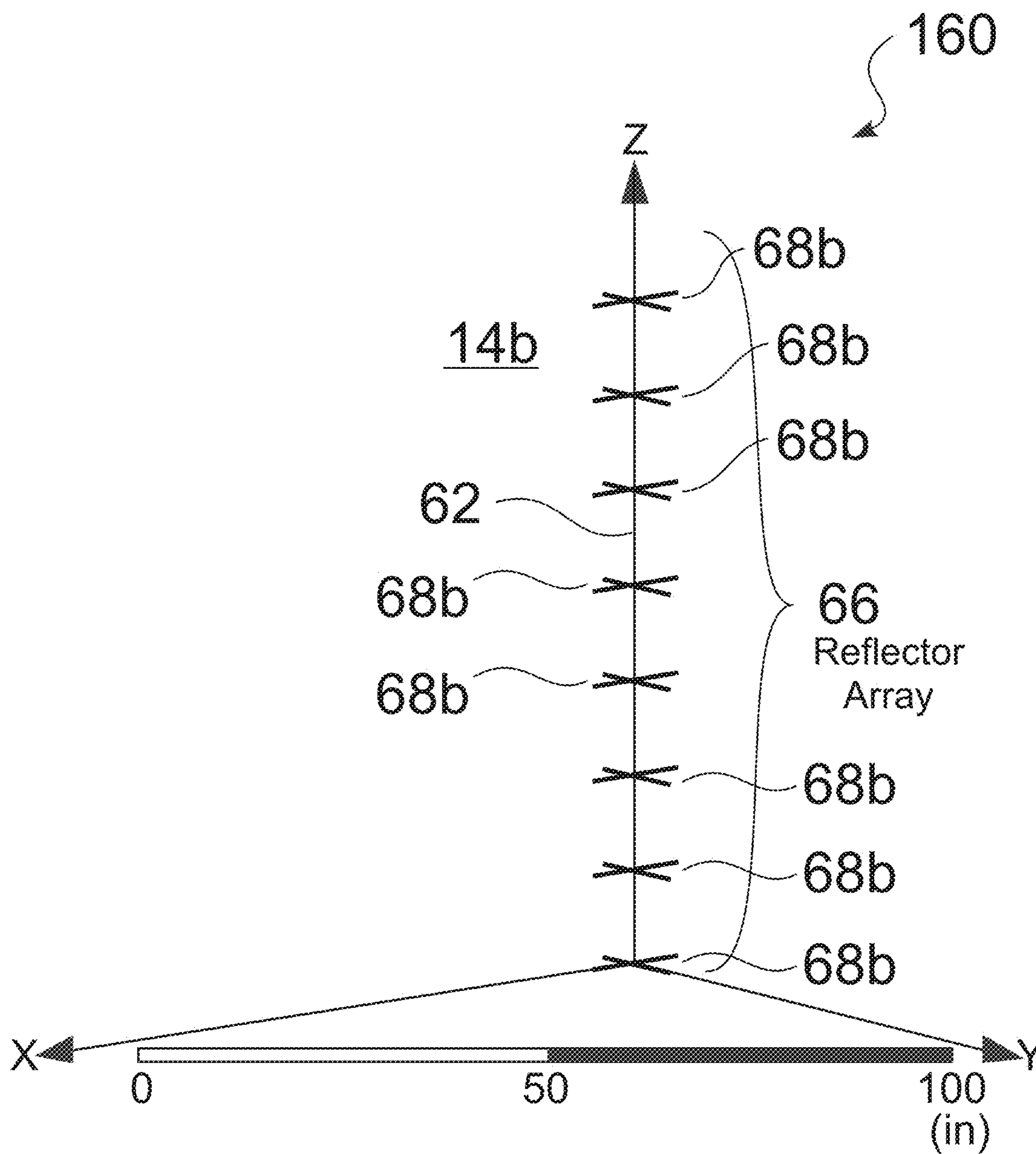
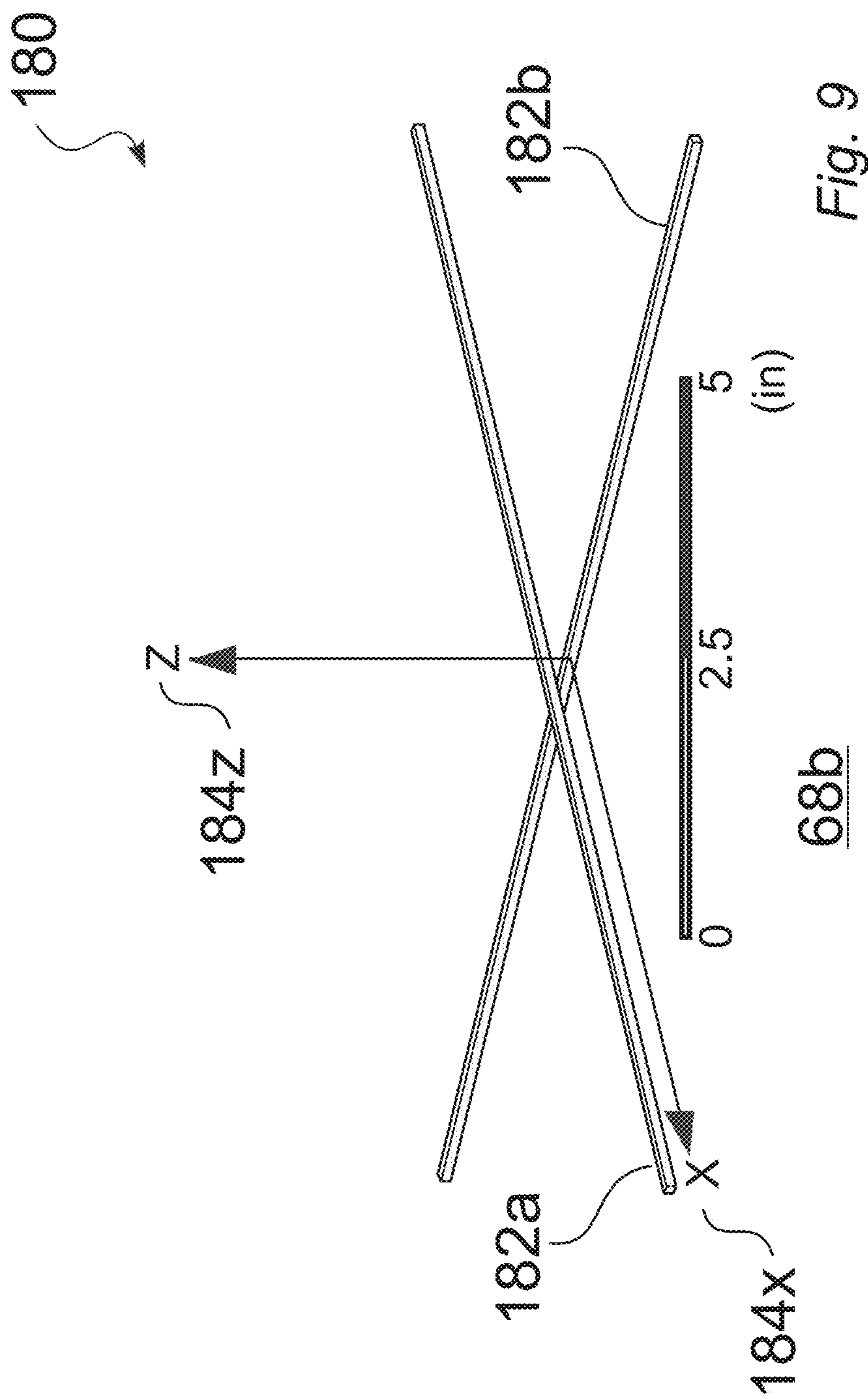

Fig. 8



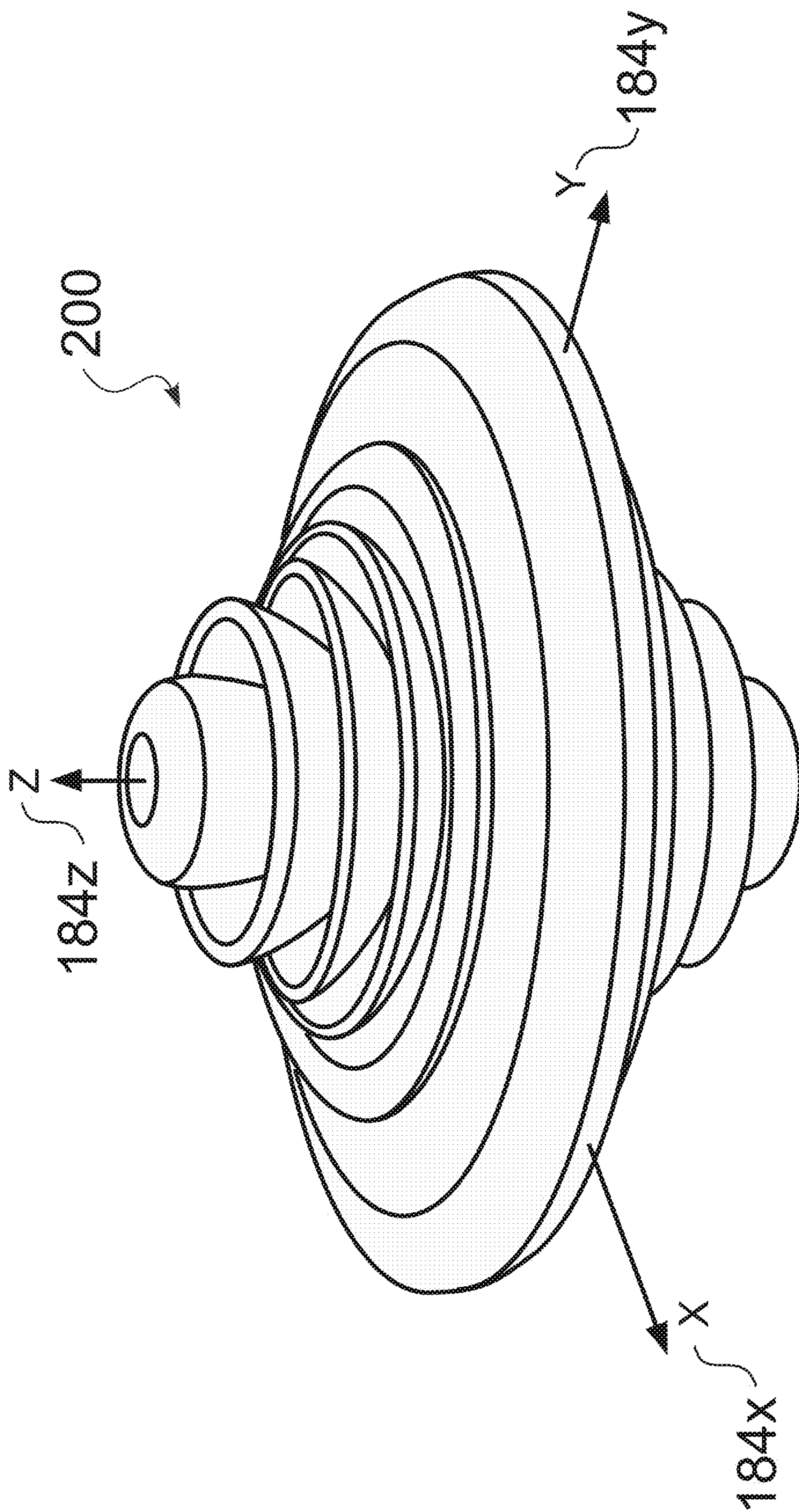

Fig. 10

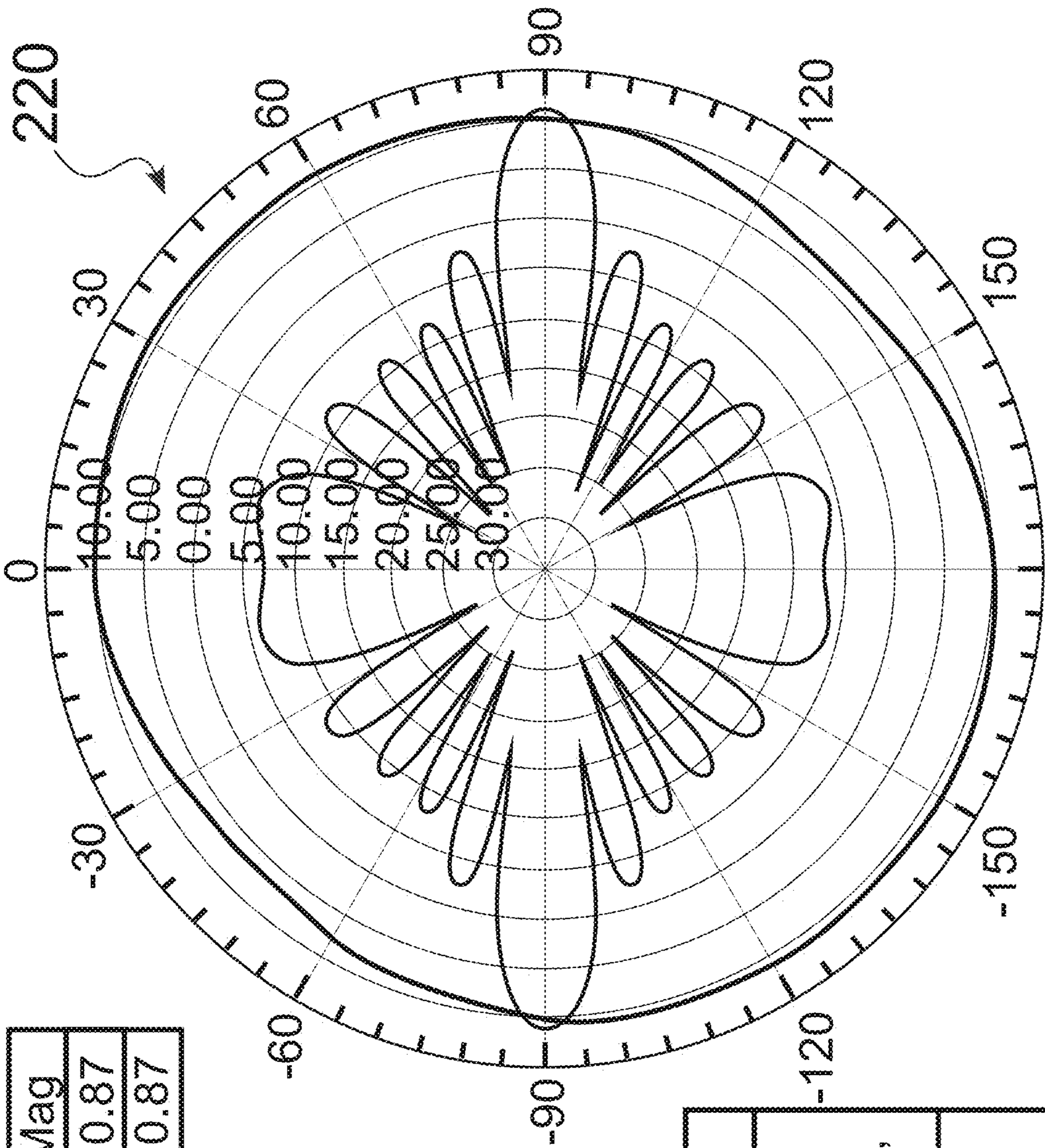
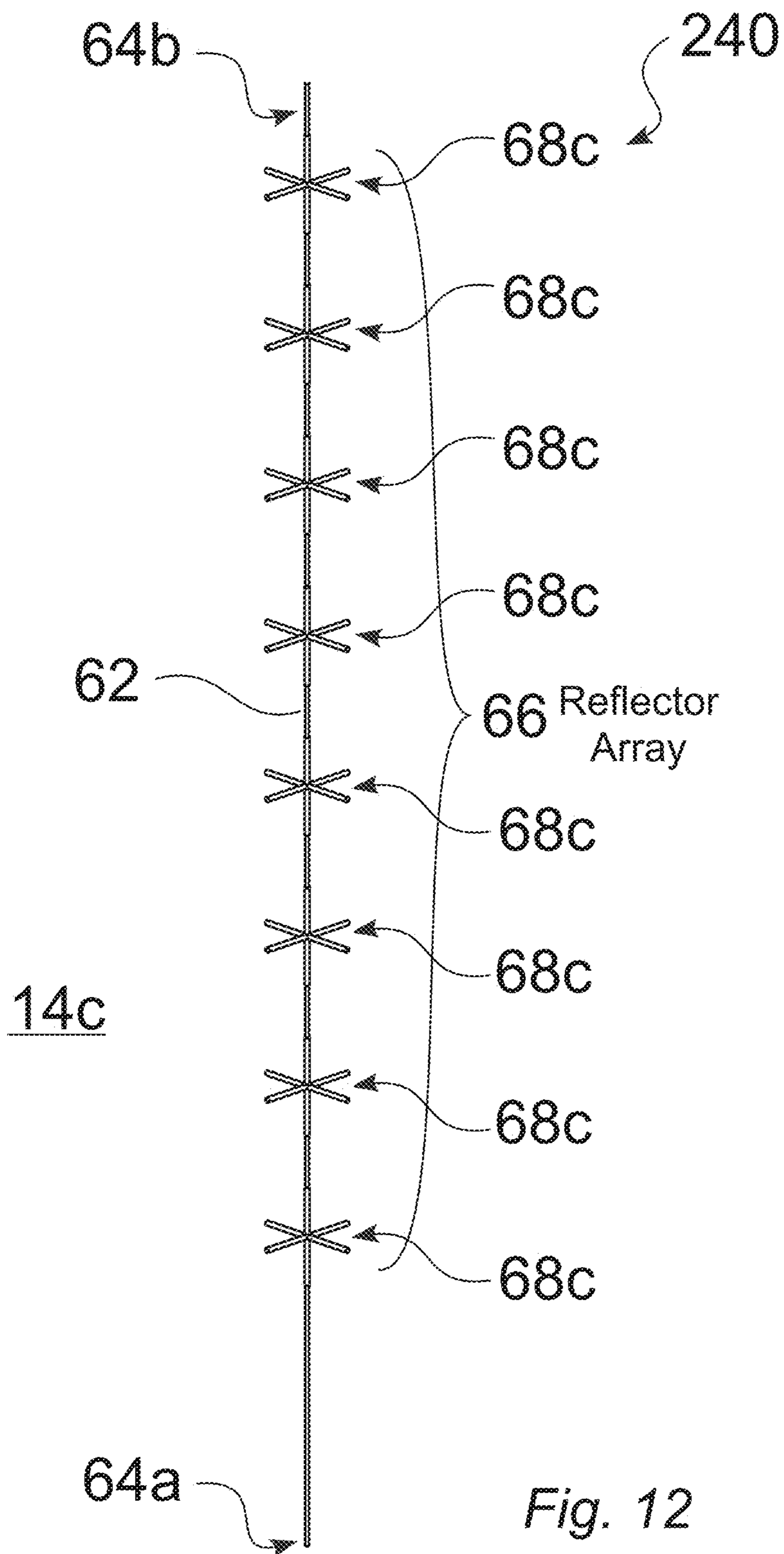
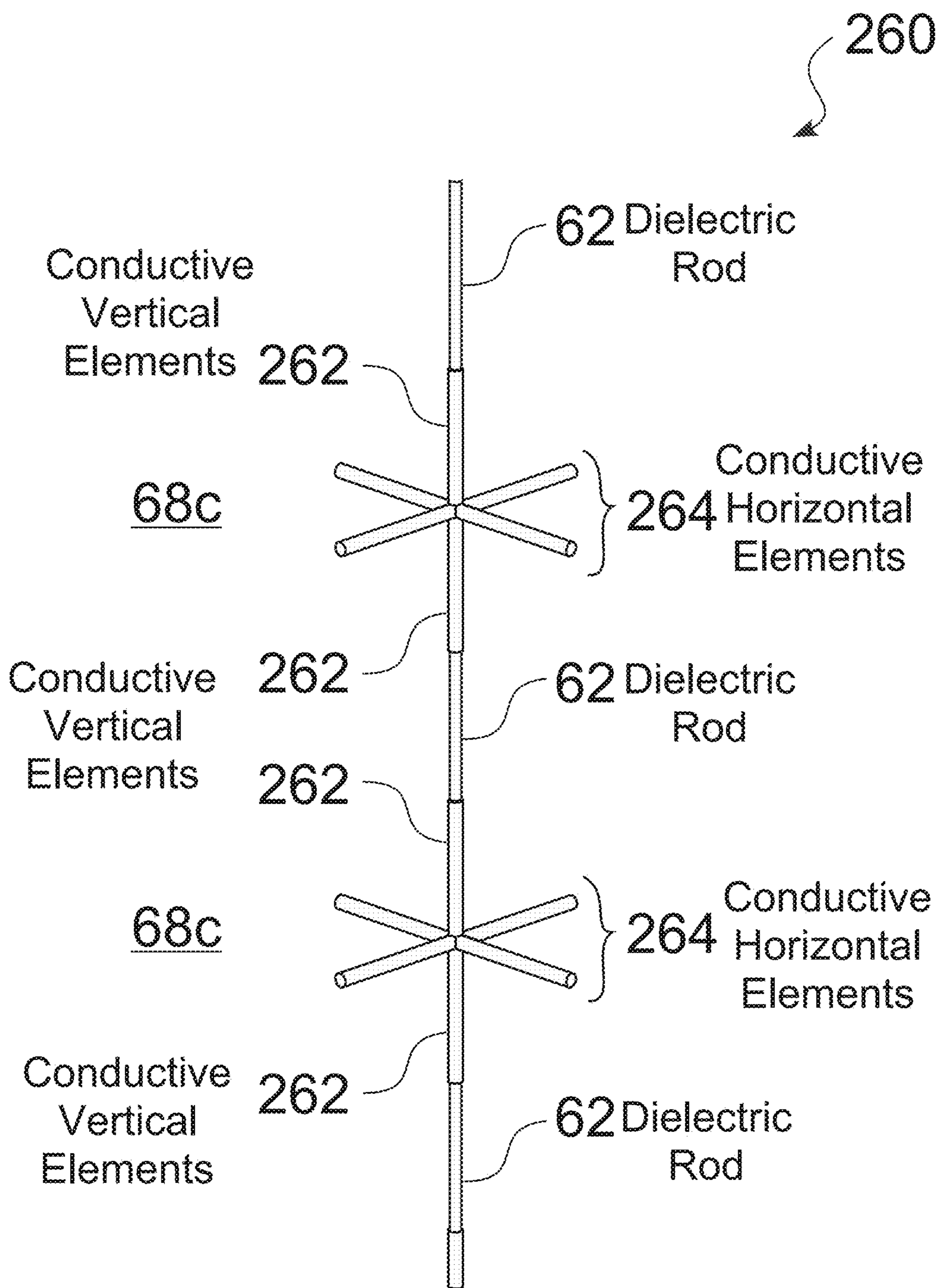

Fig. 11

Name	Theta	Phi	Ang	Mag
m1	90.00		90.00	10.87
m2		36.00	36.00	10.87

Curve Info	
—	dB (Realized Gain Total) Setup 1: Last Adaptive Freq= '0.4GHz' Phi='36deg'
—	dB (Realized Gain Total)_1 Setup 1: Last Adaptive Freq= '0.4GHz' Theta='90deg'





14c

Fig. 13

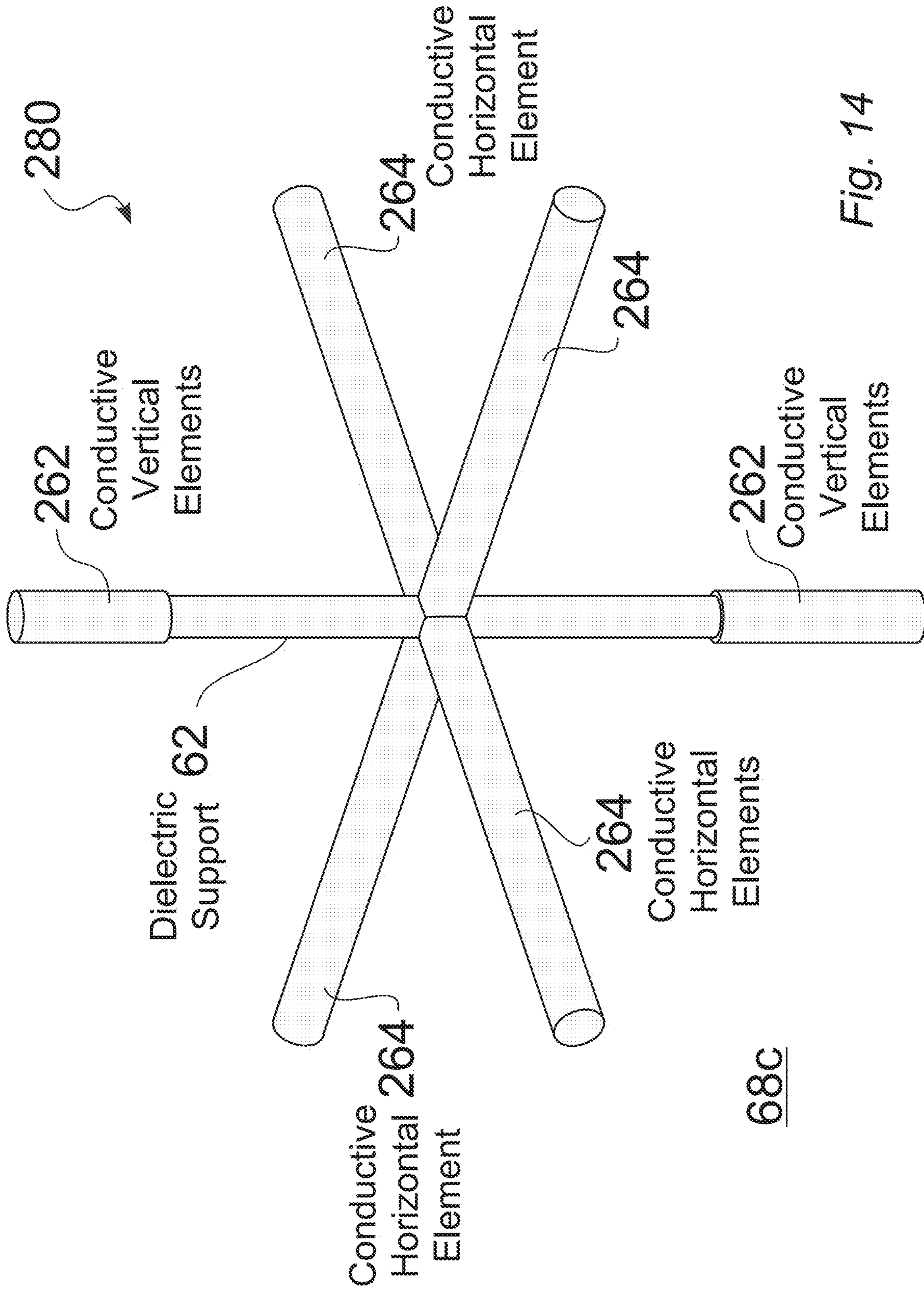

Fig. 14

68c

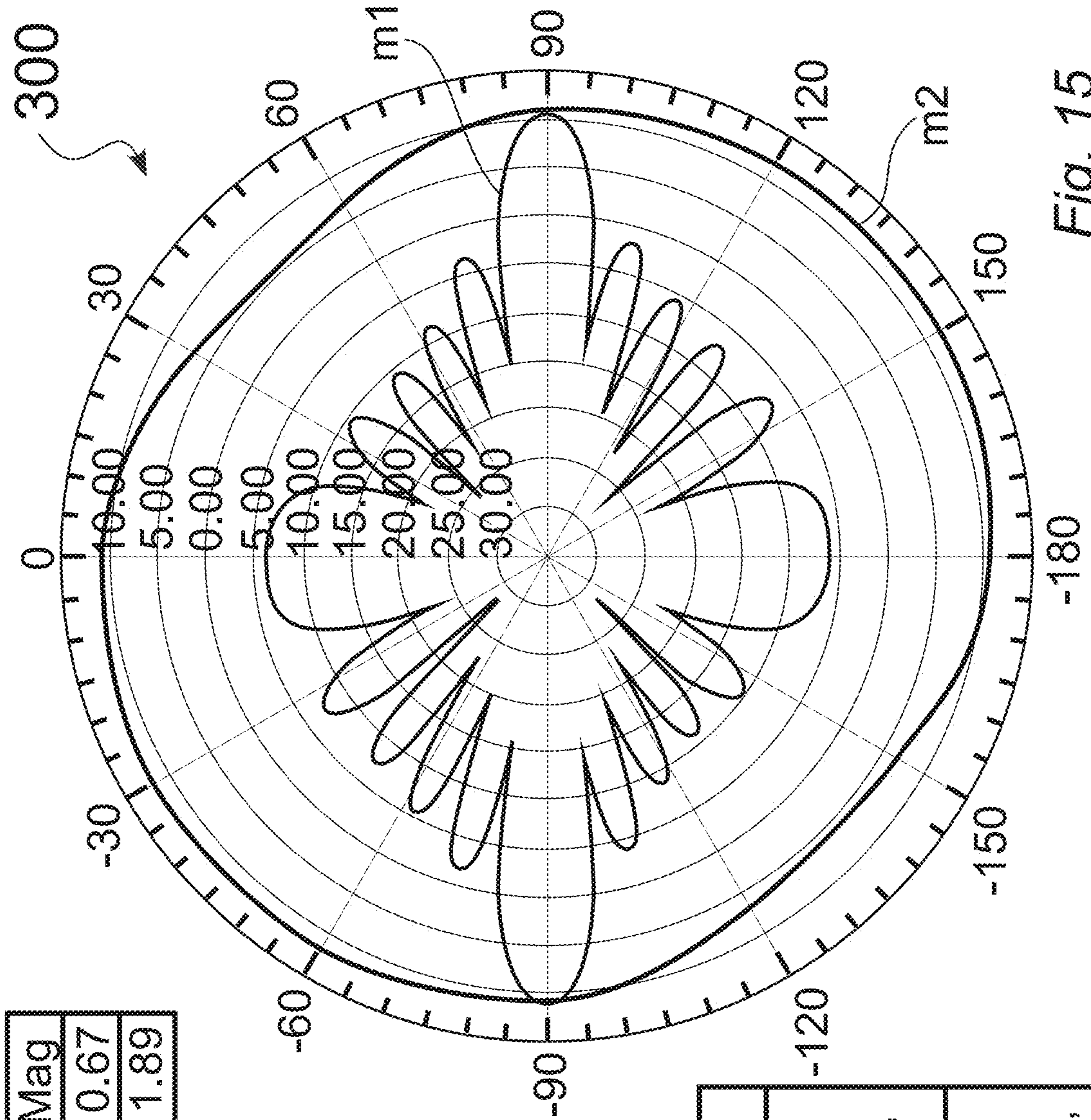

Fig. 15

Name	Theta	Phi	Ang	Mag
m1	90.00		90.00	10.67
m2		135.00	135.00	11.89

Curve Info	
—	dB (Realized Gain Total) 400MHz: Last Adaptive Freq= '0.4GHz' Phi='36deg'
- - -	dB (Realized Gain Total)_1 400MHz: Last Adaptive Freq= '0.4GHz' Theta='90deg'

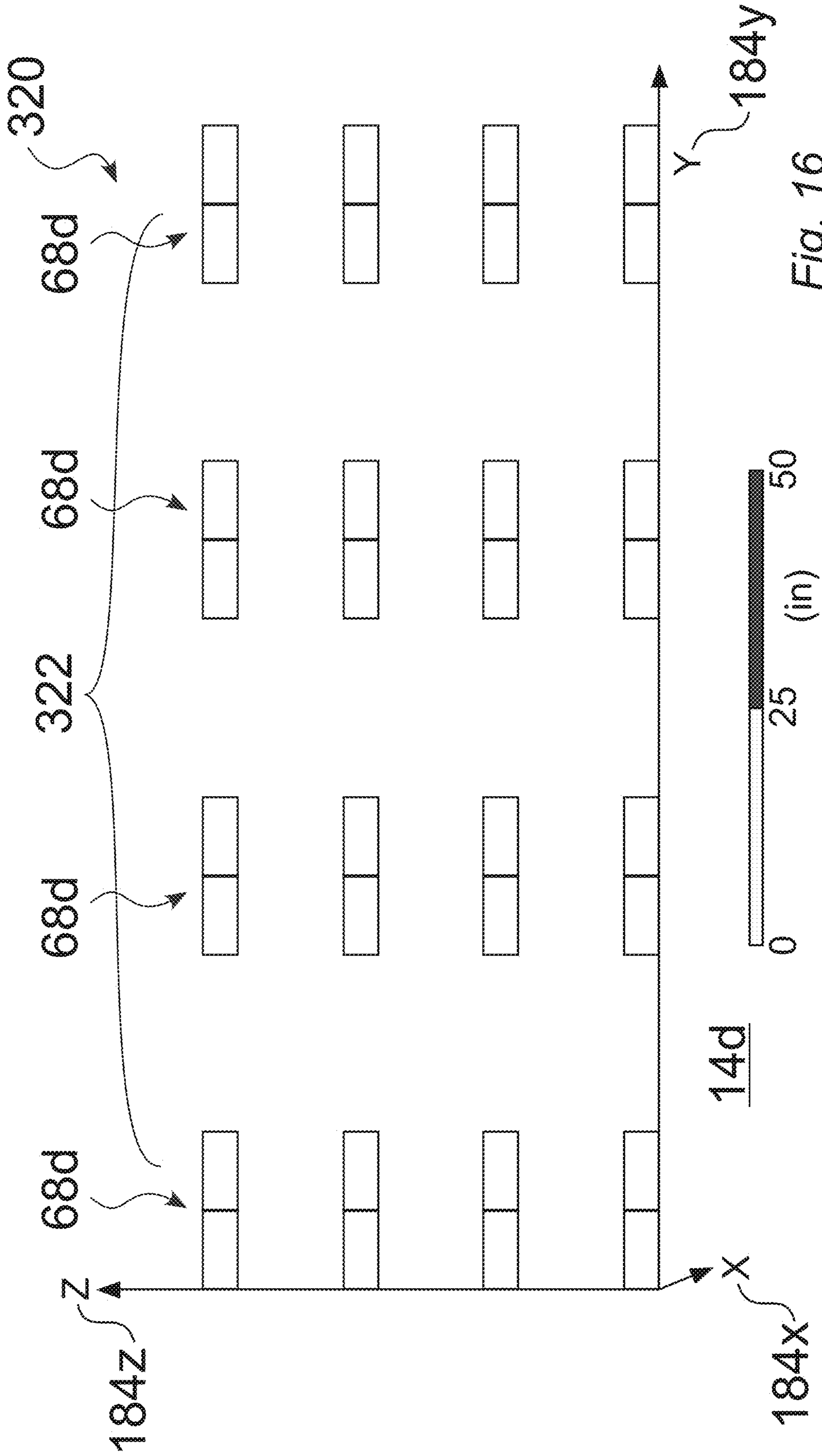

Fig. 16

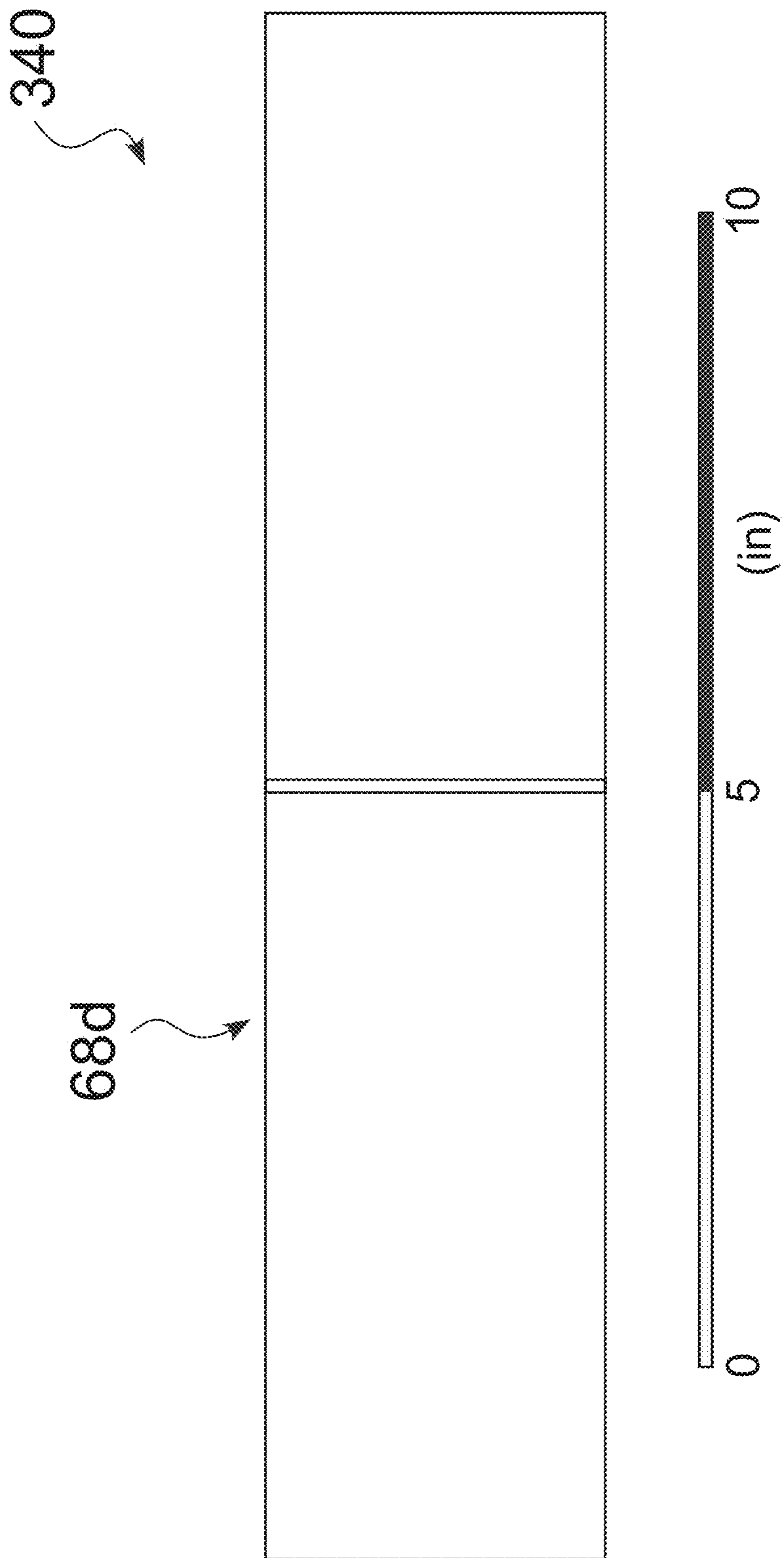

Fig. 17

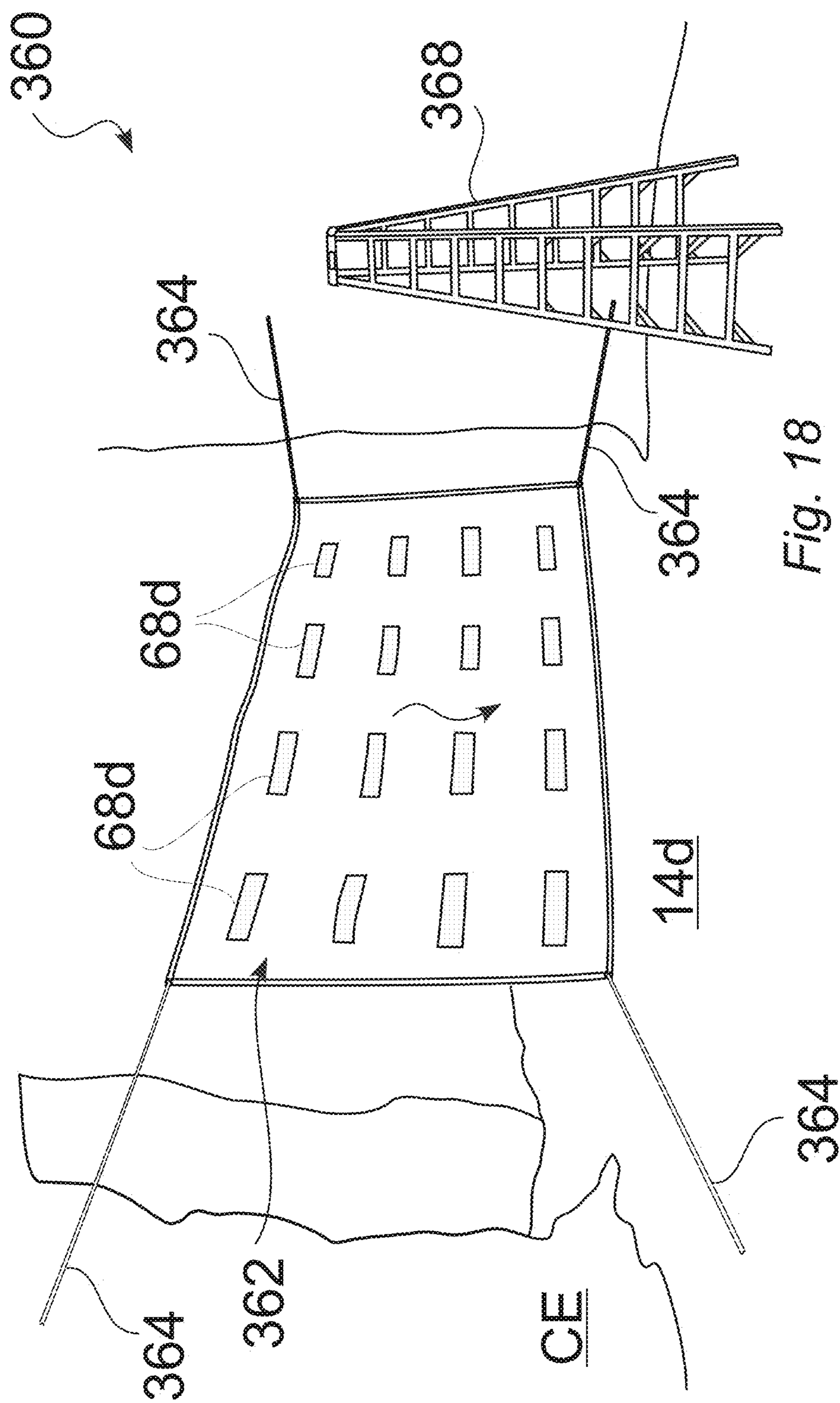

Fig. 18

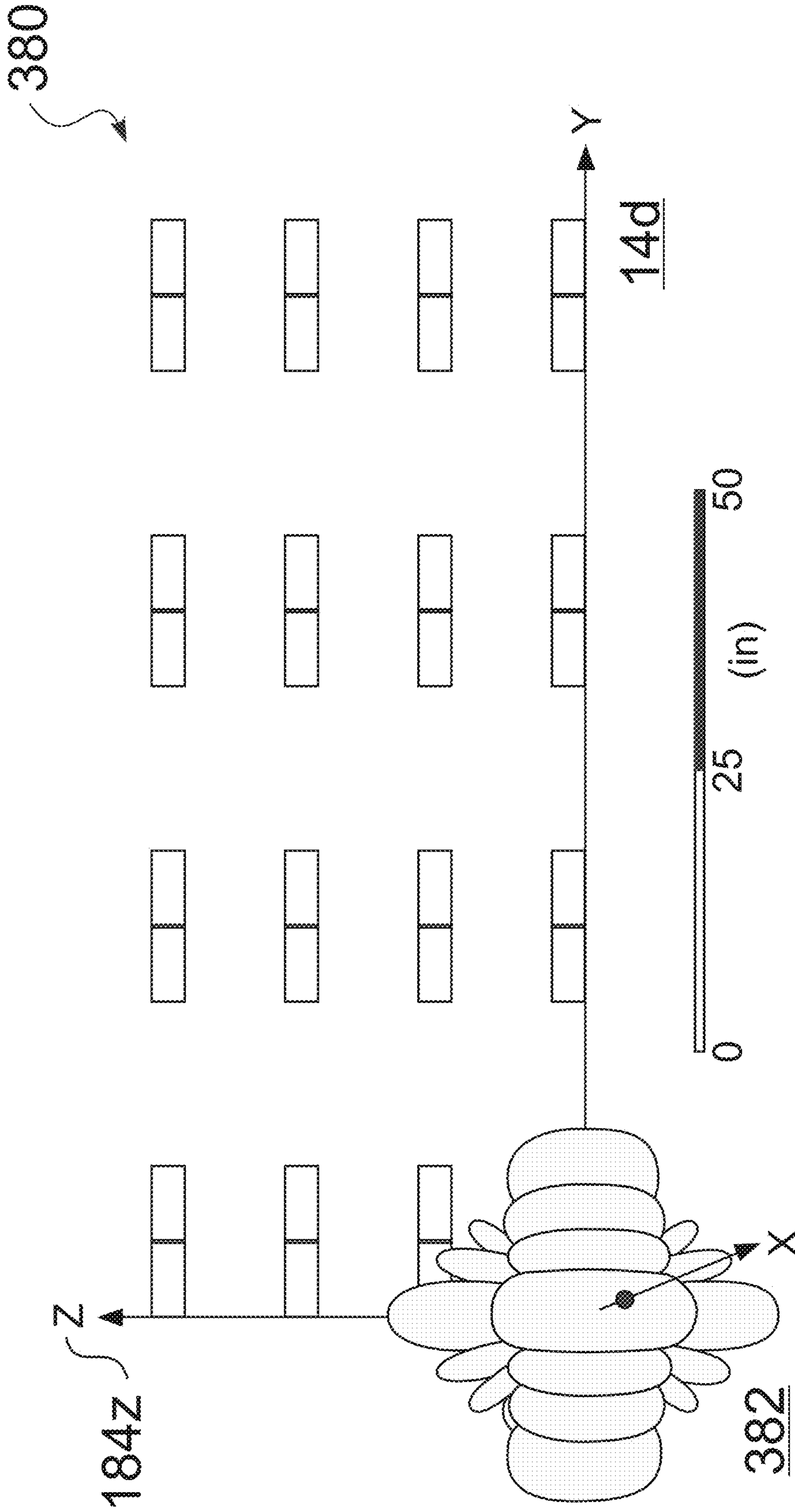
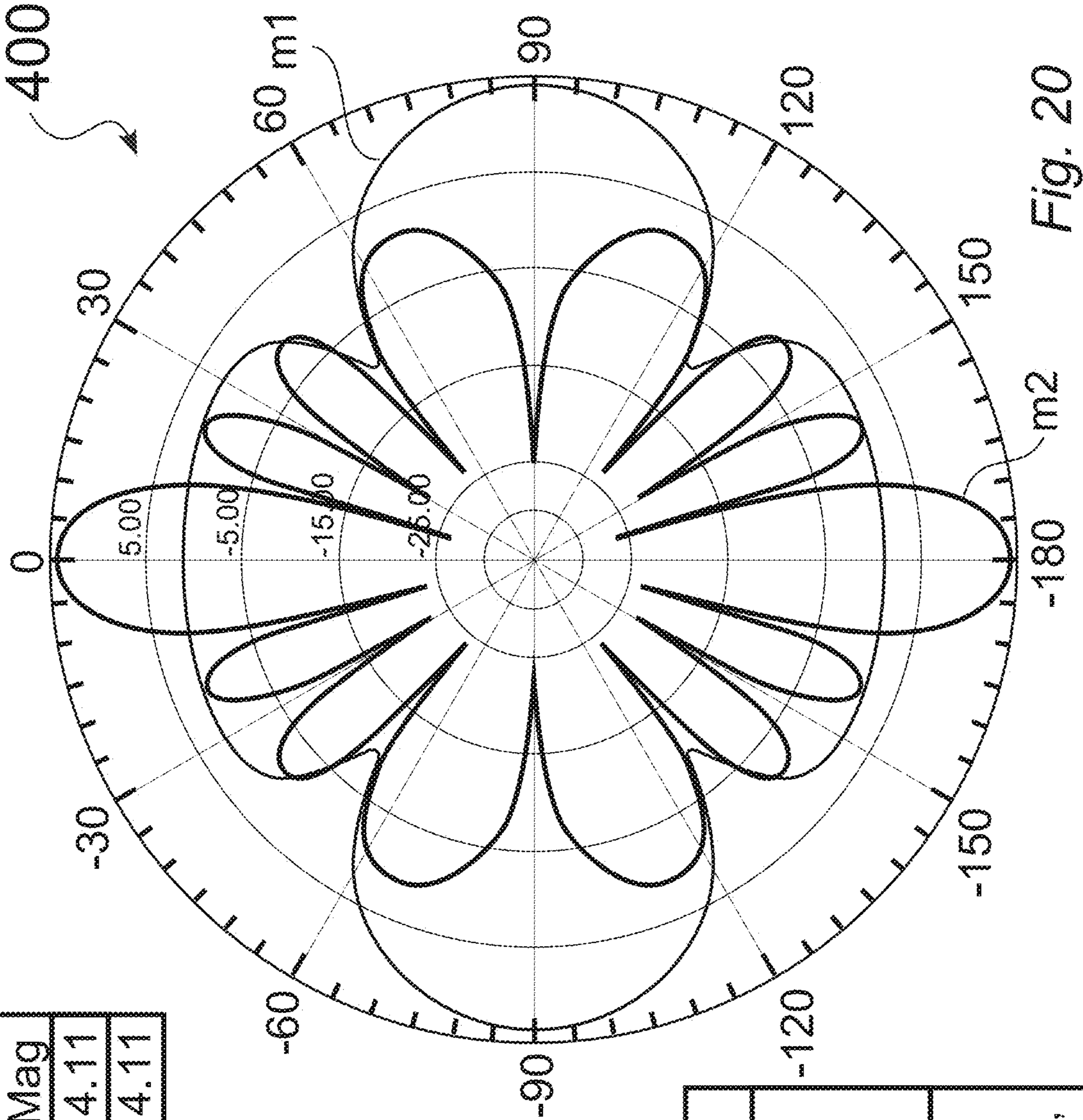
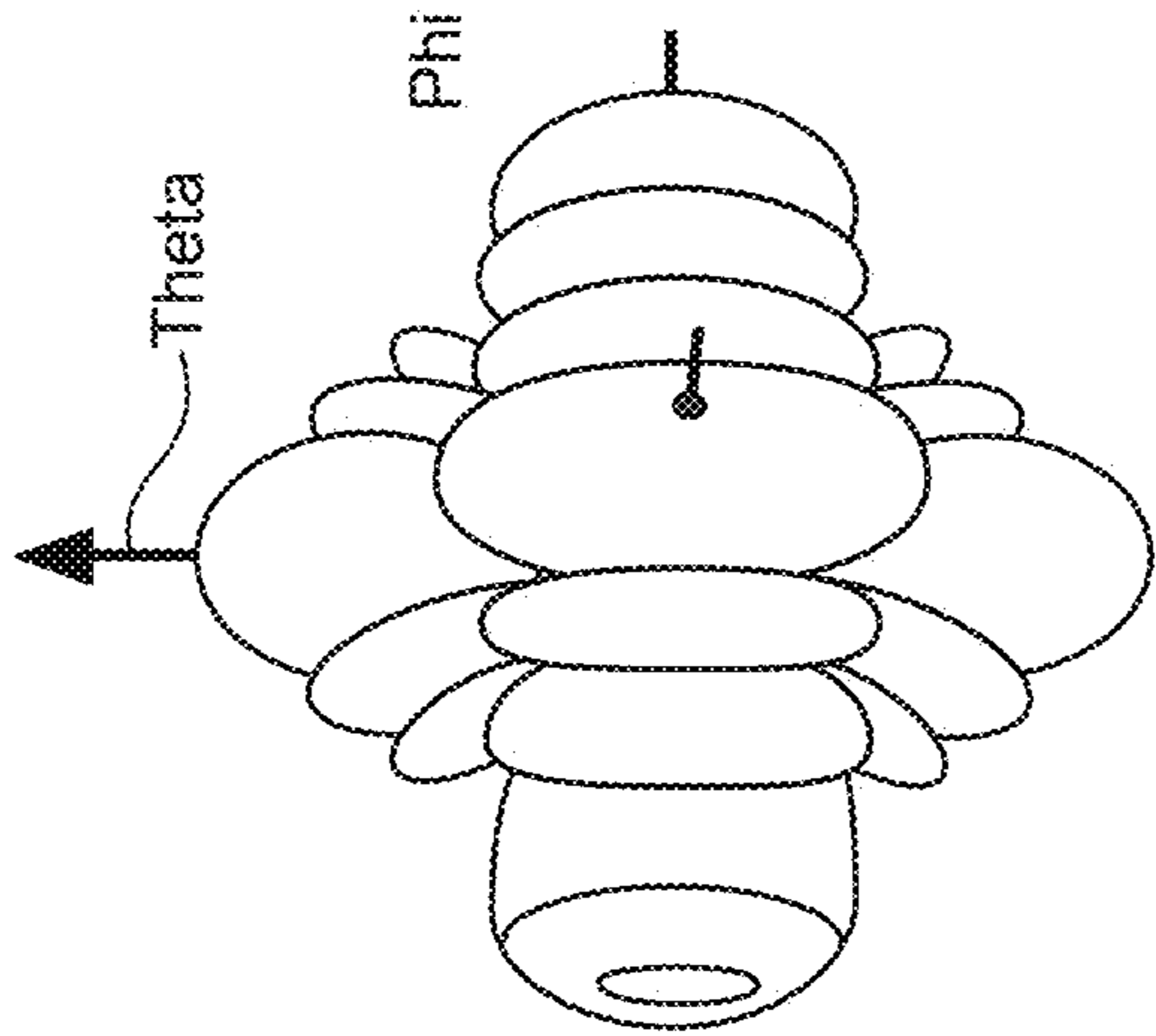

Fig. 19

Name	Theta	Phi	Ang	Mag
m1	90.00		90.00	14.11
m2		0.00	0.00	14.11



Curve Info	
—	dB (Realized Gain Total) 400MHz: Last Adaptive Freq= '0.4GHz' Phi='0deg'
- -	dB (Realized Gain Total)_1 400MHz: Last Adaptive Freq= '0.4GHz' Theta='90deg'

Fig. 20

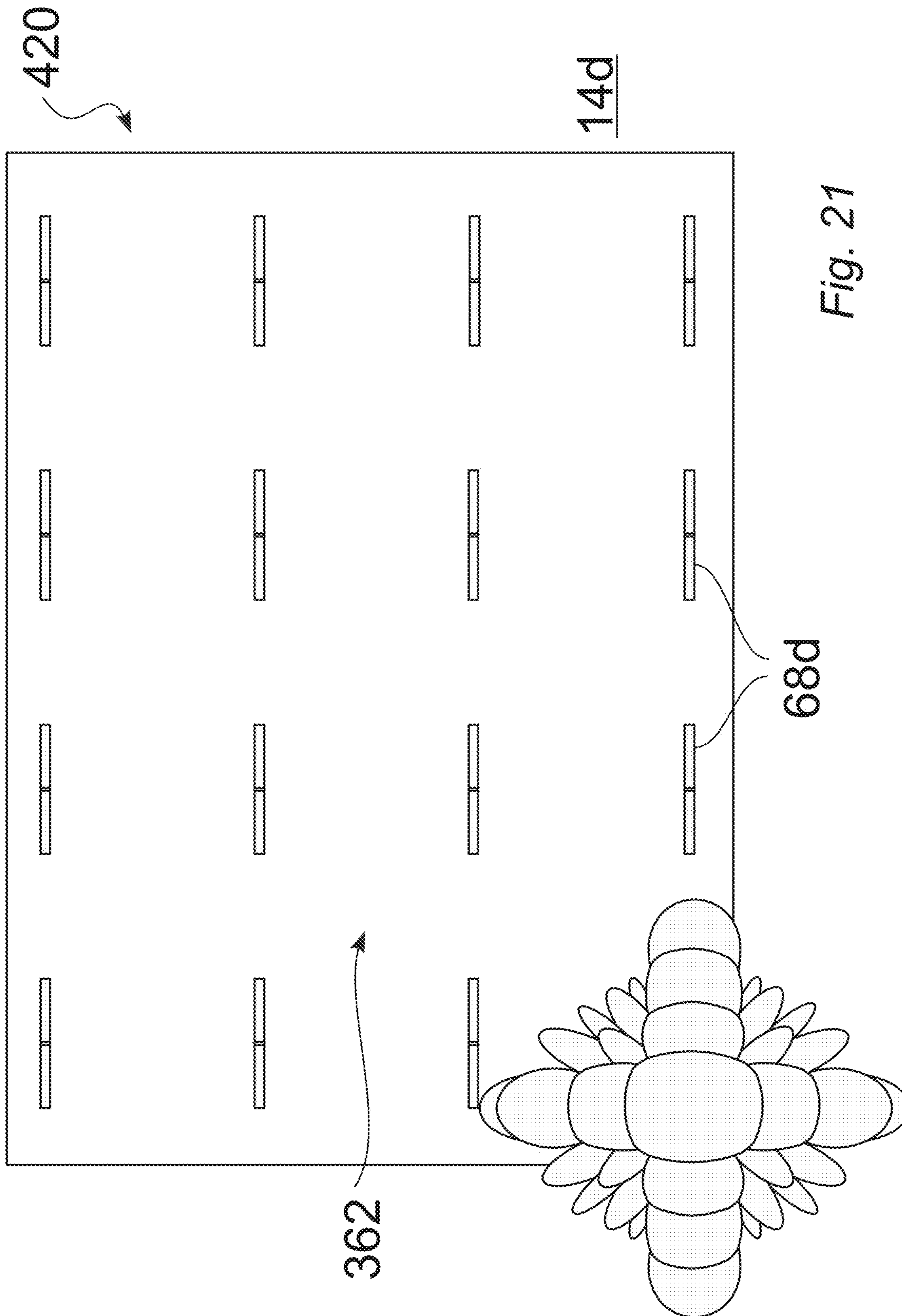

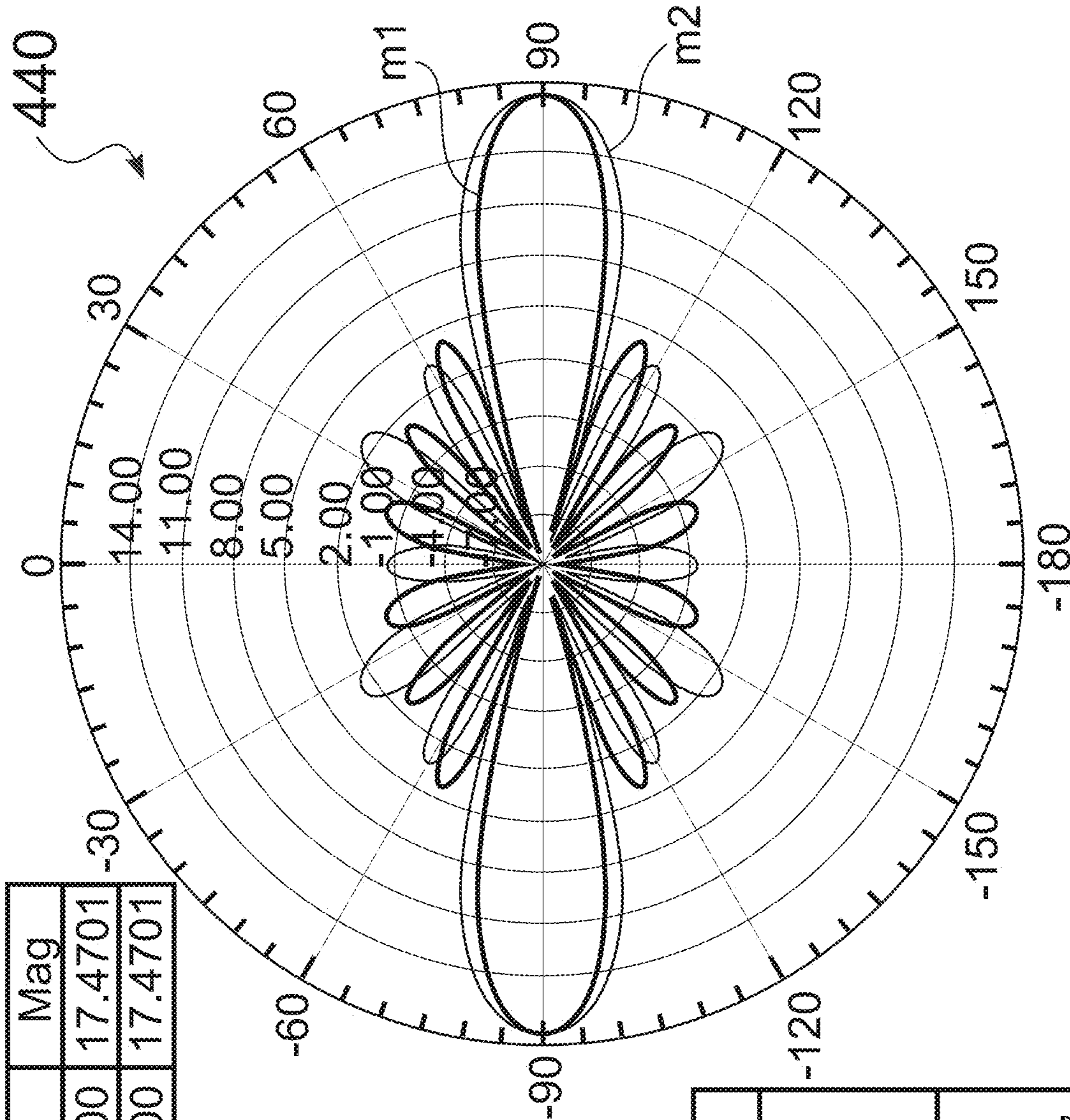

Name	Theta	Phi	Ang	Mag
m1		90.0000	90.0000	17.4701
m2	90.000		90.0000	17.4701

Curve Info	
—	dB (Realized Gain Total) 400MHz: Last Adaptive Freq= '0.4GHz' Phi='0deg'
—	dB (Realized Gain Total)_1 400MHz: Last Adaptive Freq= '0.4GHz' Theta='90deg'

Fig. 22

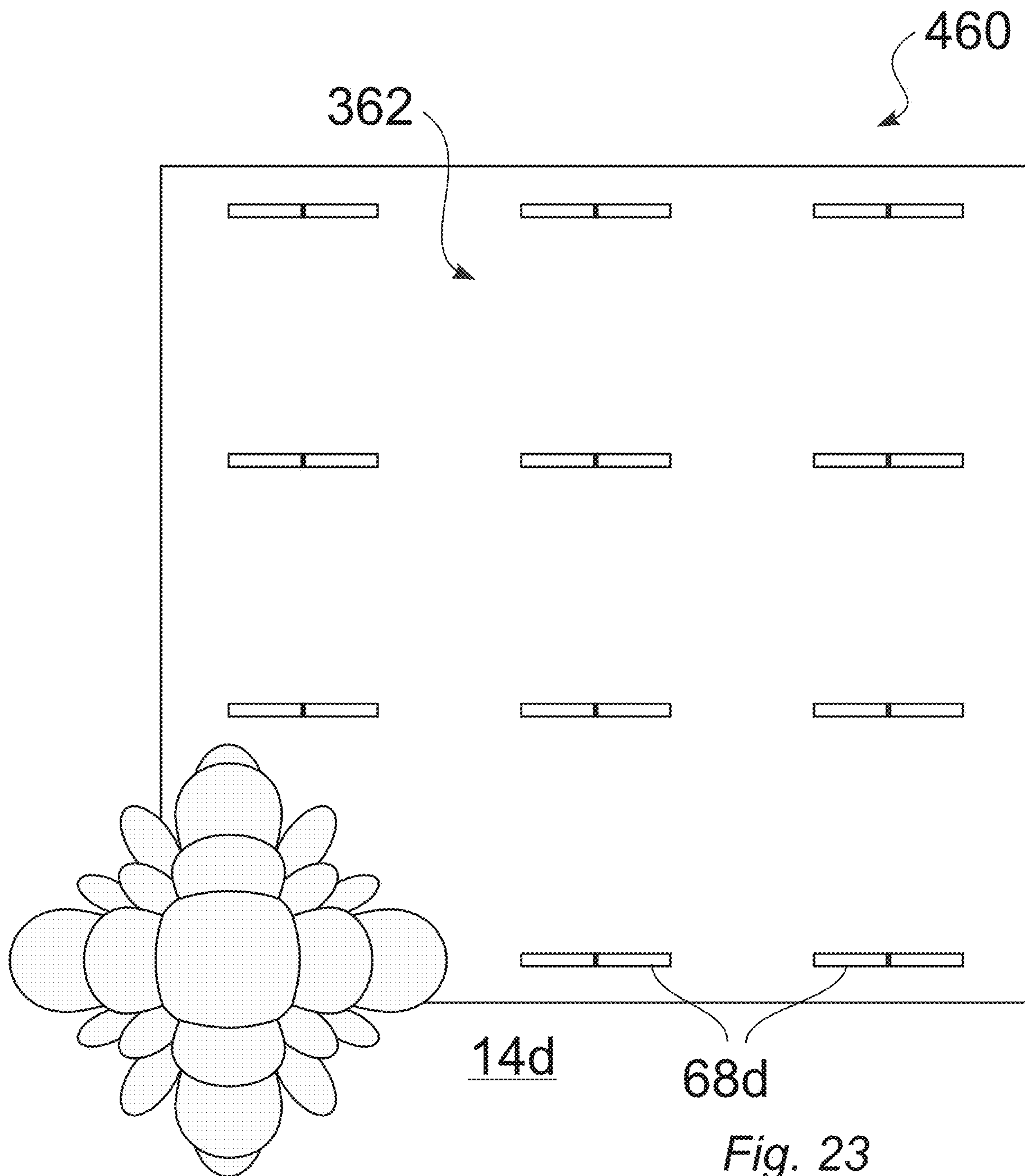

Name	Theta	Phi	Ang	Mag
m1		0.0000	90.0000	15.9257
m2	90.000		90.0000	15.9257

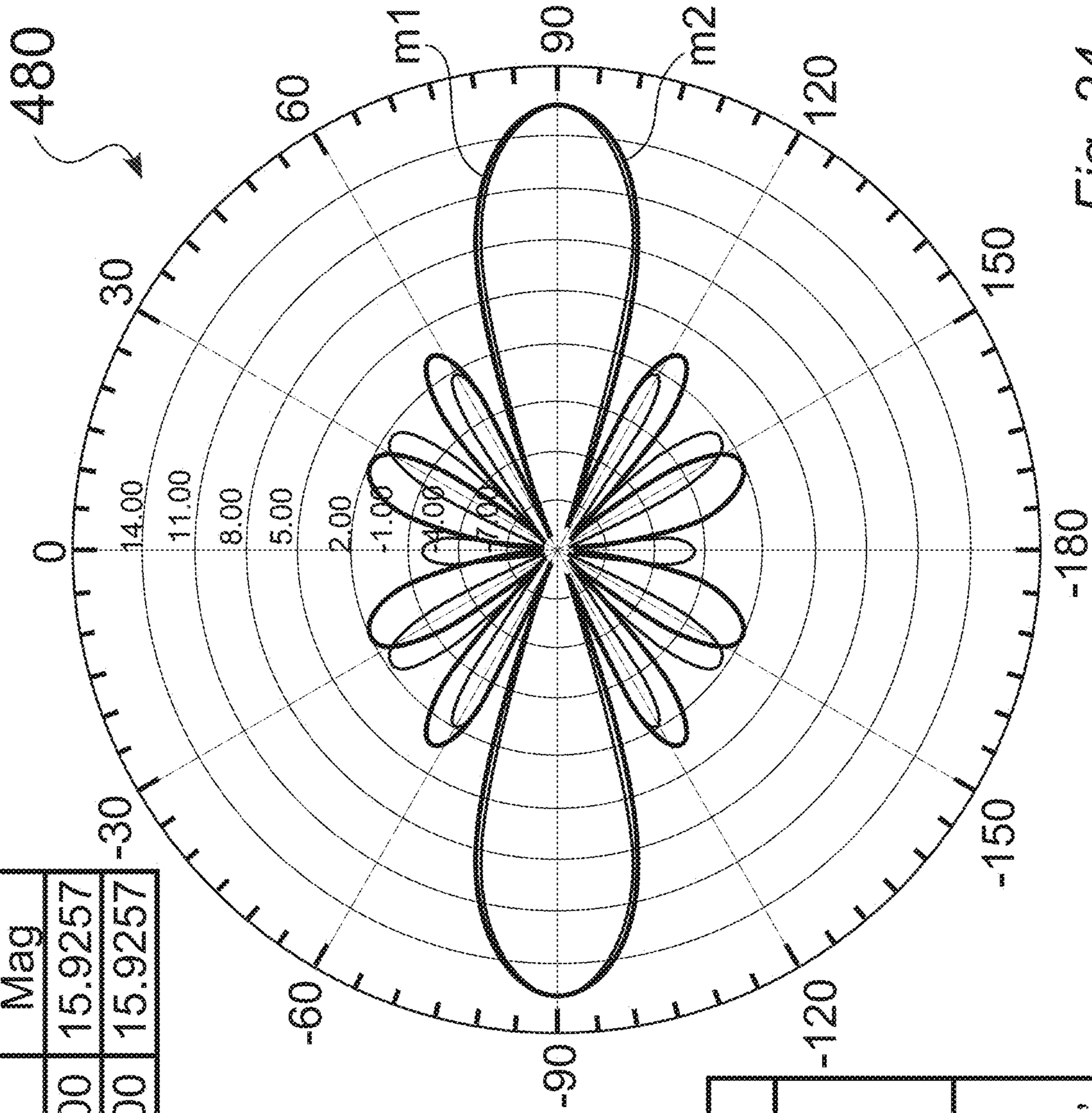

Curve Info	
—	dB (Realized Gain Total) 400MHz: Last Adaptive Freq= '0.4GHz' Phi='0deg'
—	dB (Realized Gain Total) 400MHz: Last Adaptive Freq= '0.4GHz' Theta='90deg'

Fig. 24

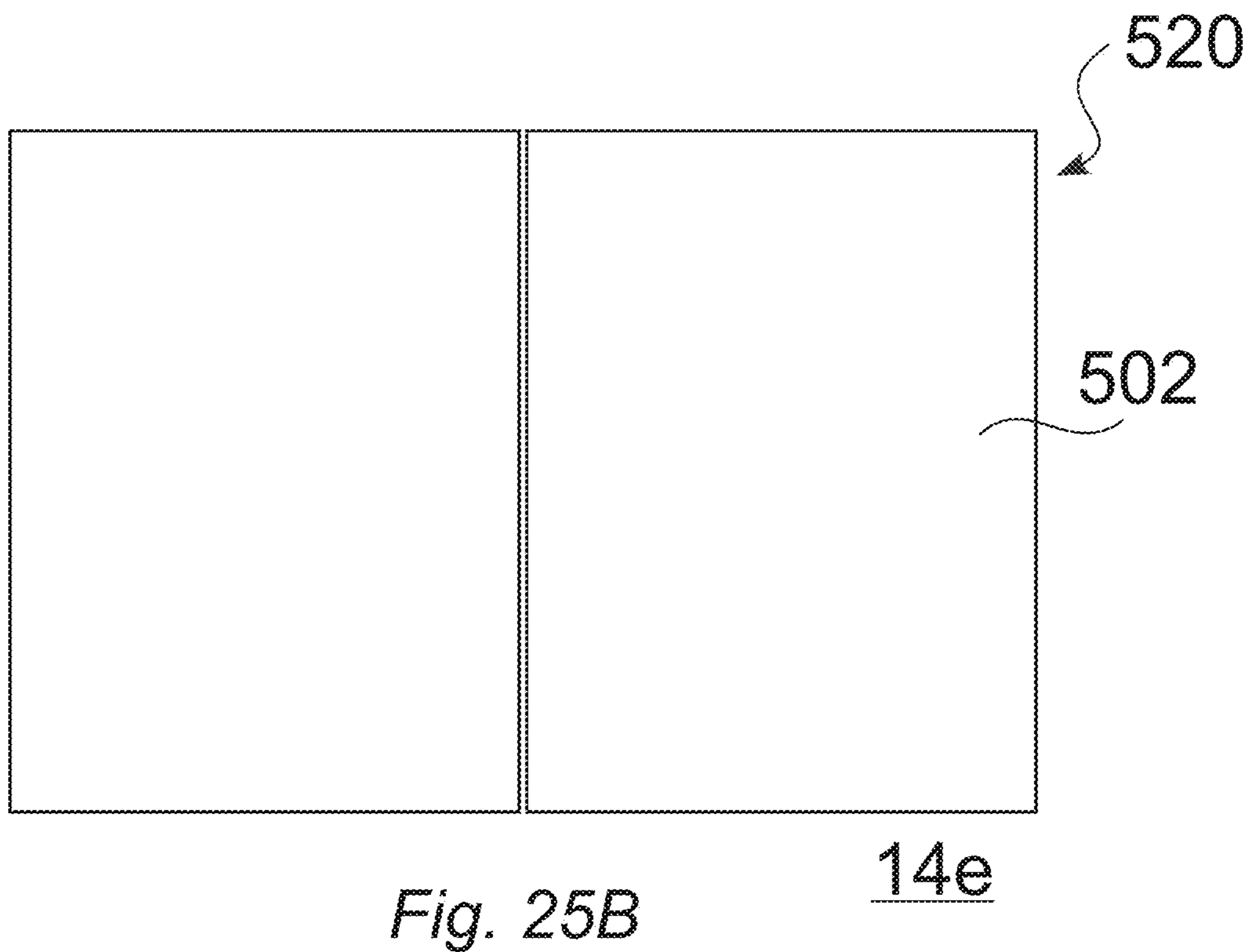
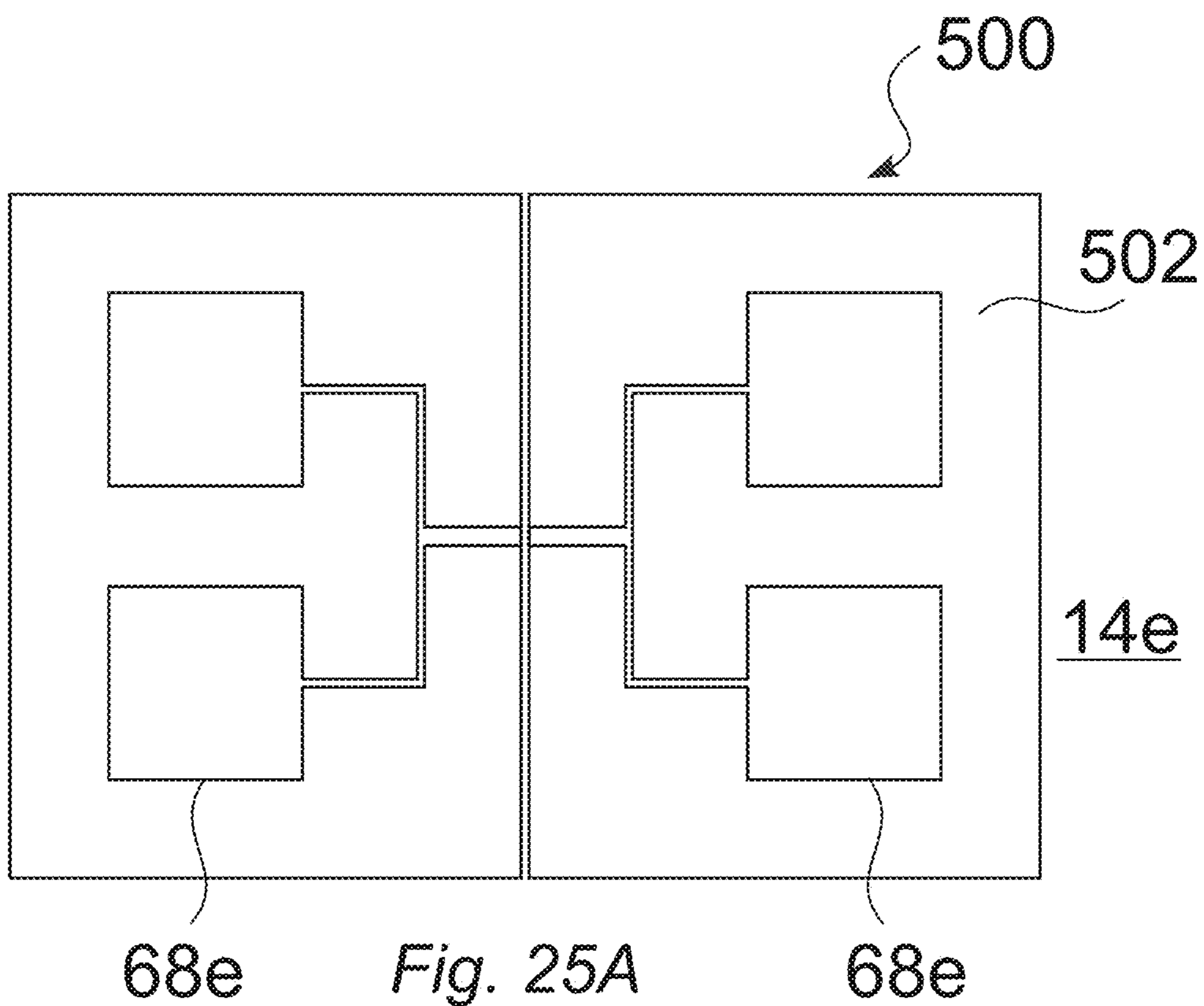

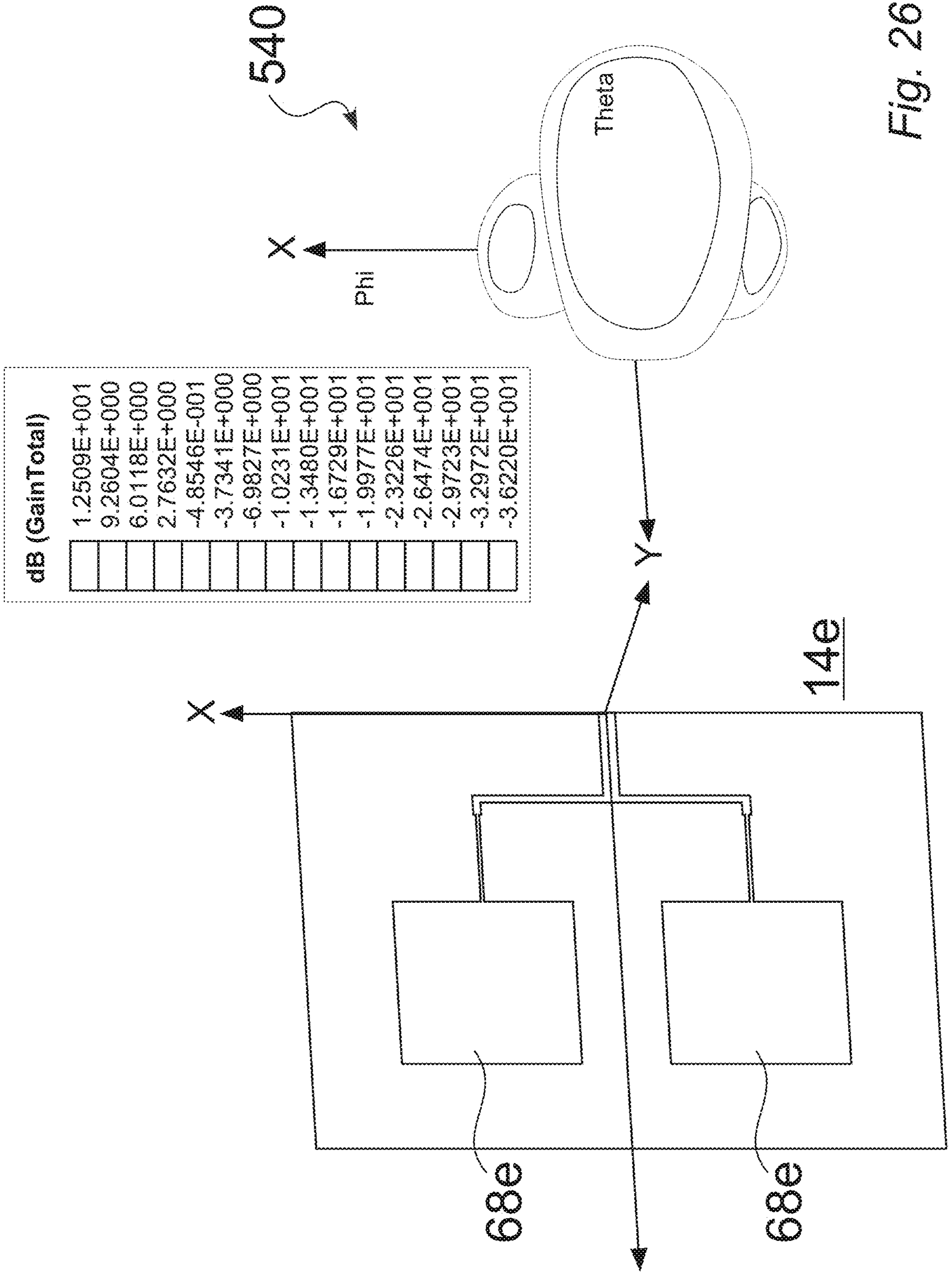

Fig. 26

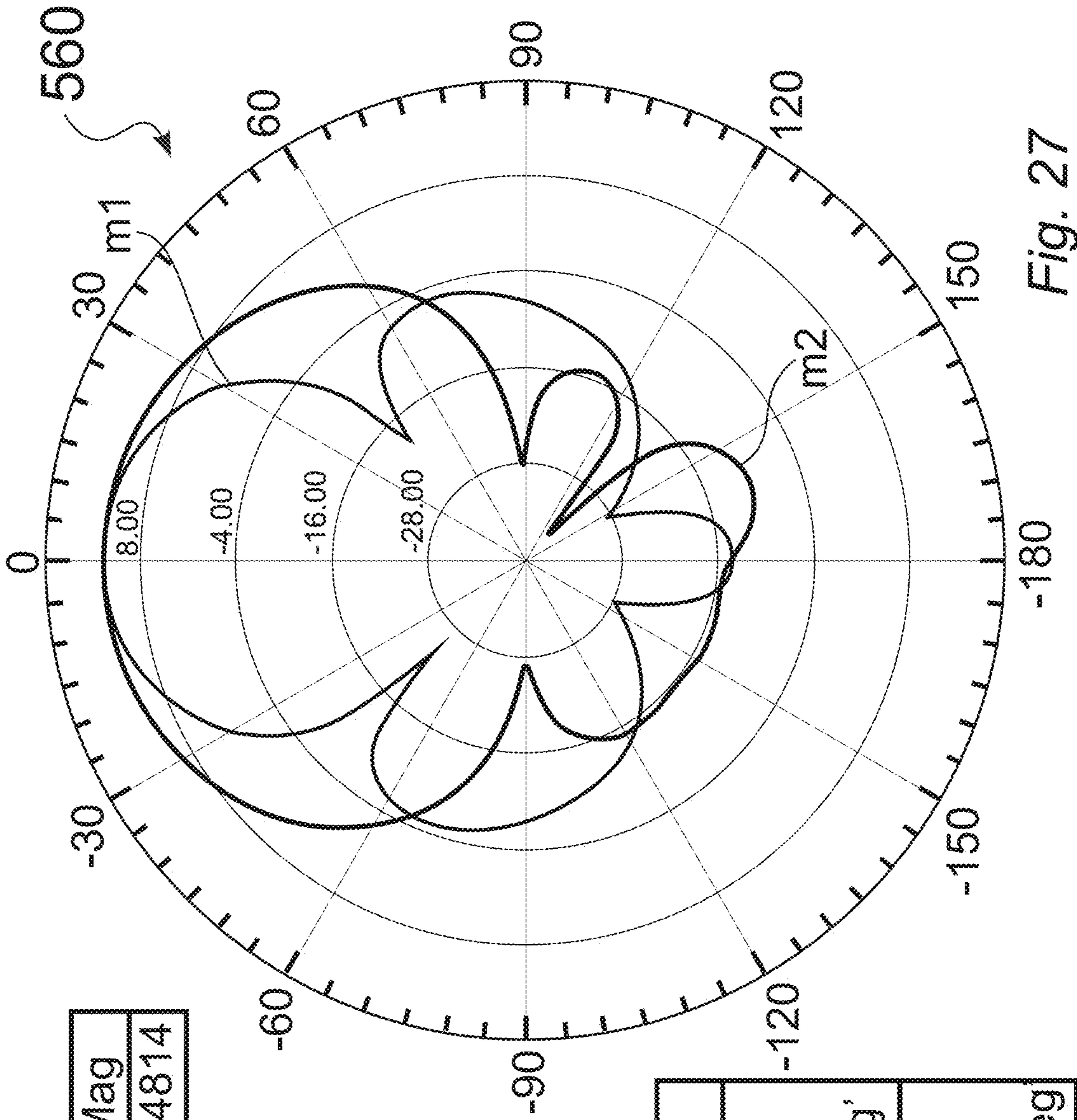

Fig. 27

Name	Theta	Ang	Mag
m1	0.0000	0.0000	12.4814

Curve Info	
—	dB (Realized Gain Total) Setup 1: Last Adaptive Freq= '0.415GHz' Phi='0deg'
---	dB (Realized Gain Total)_1 Setup 1: Last Adaptive Freq= '0.415GHz' Theta='90deg'

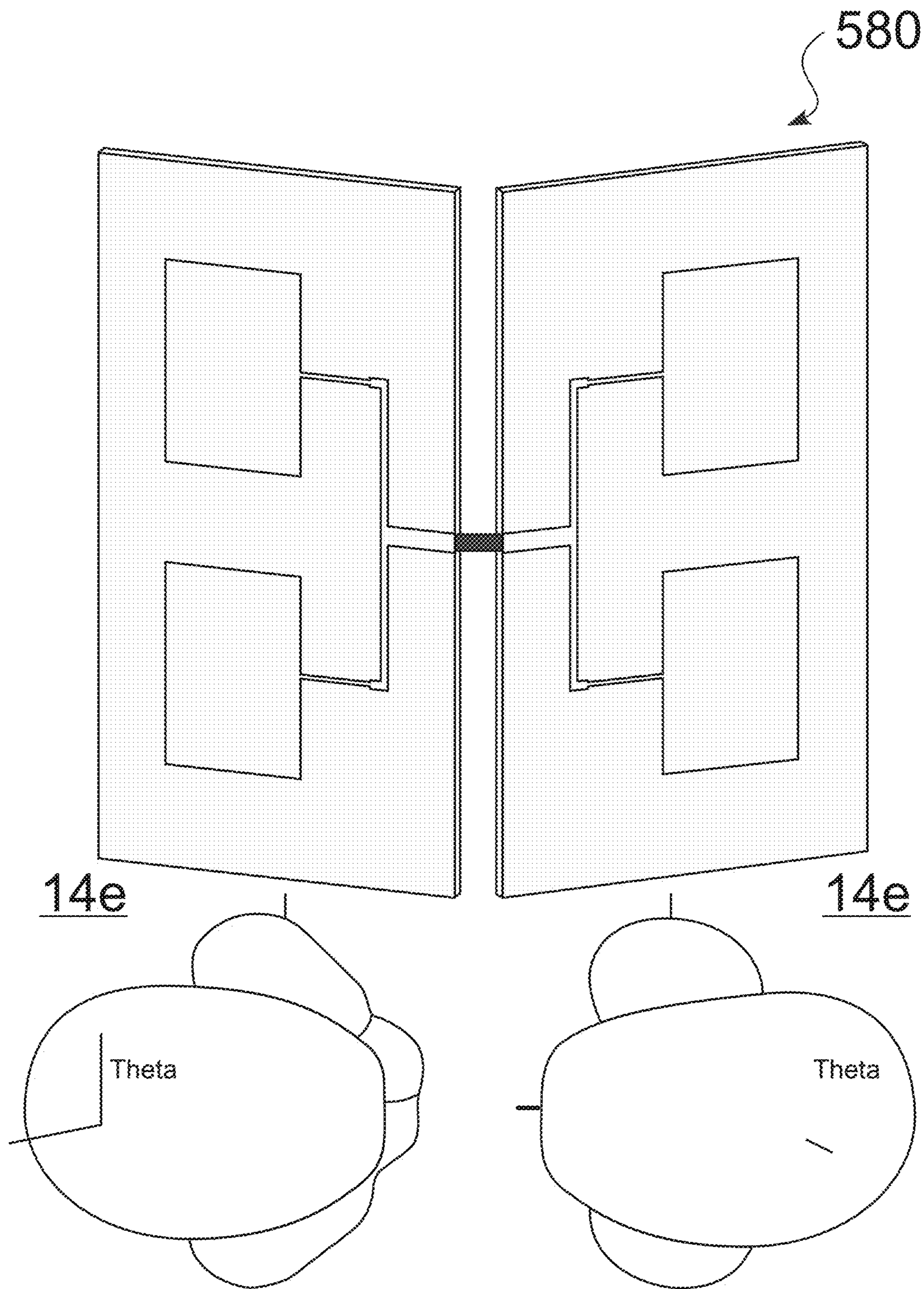

Fig. 28

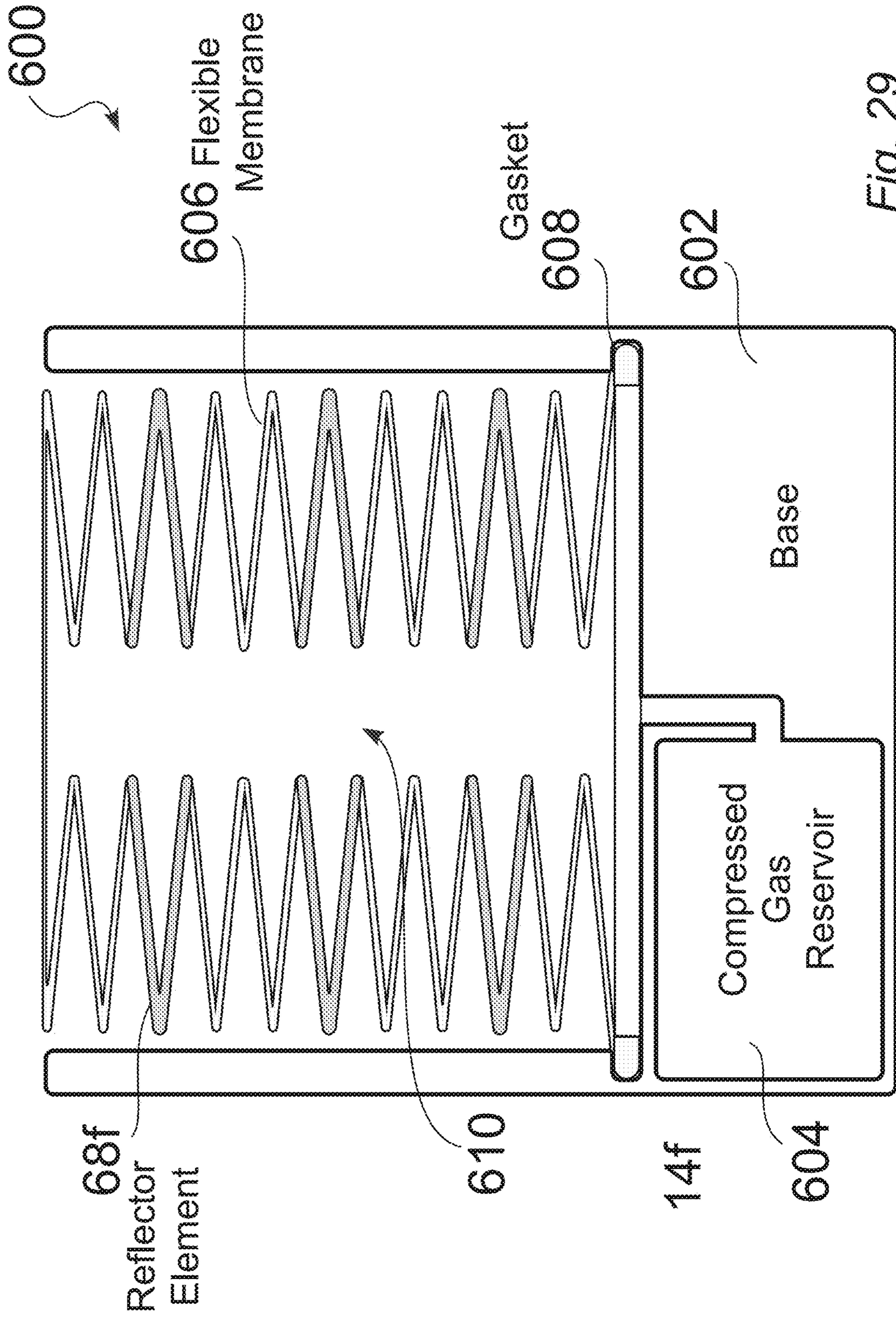

Fig. 29

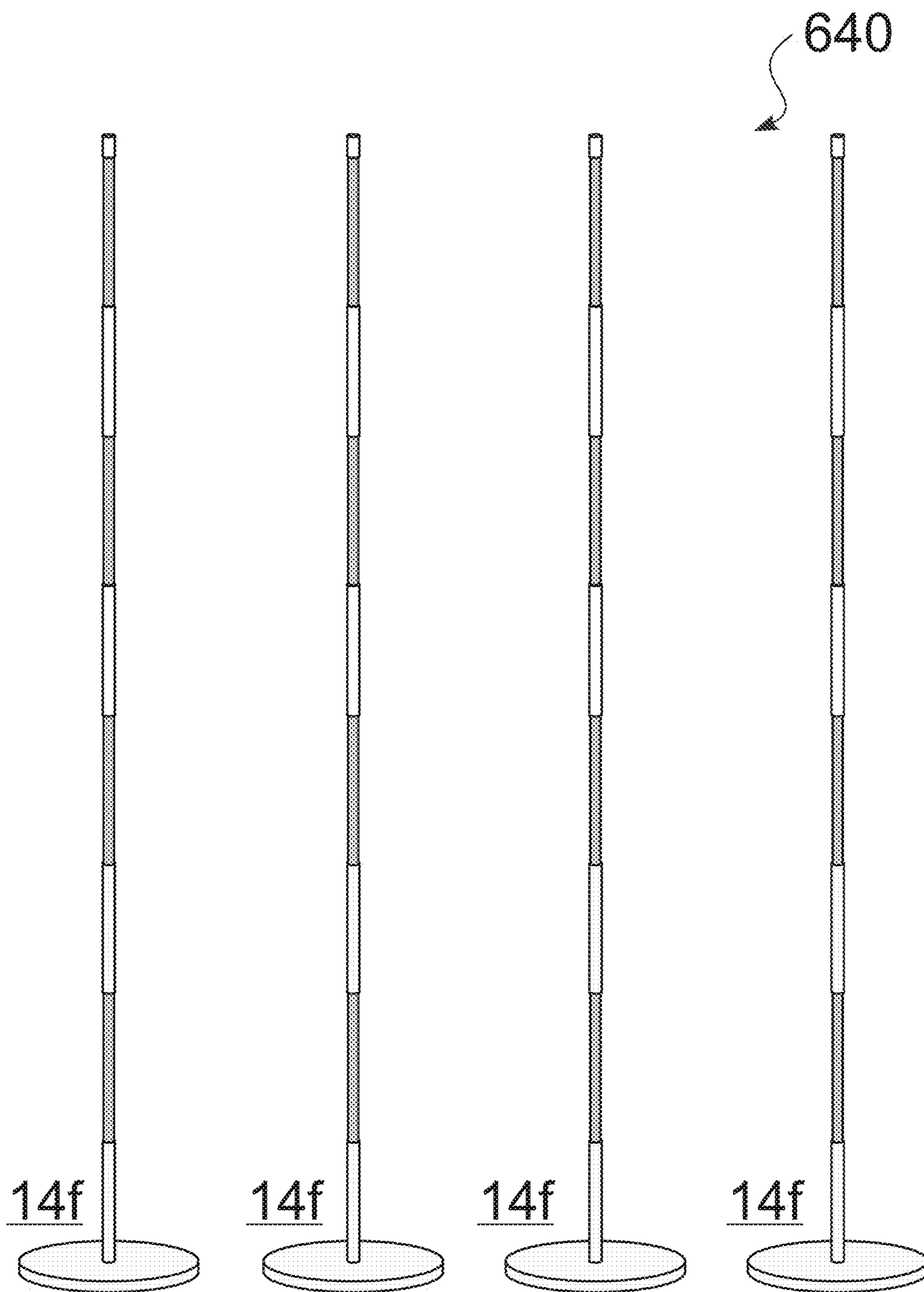
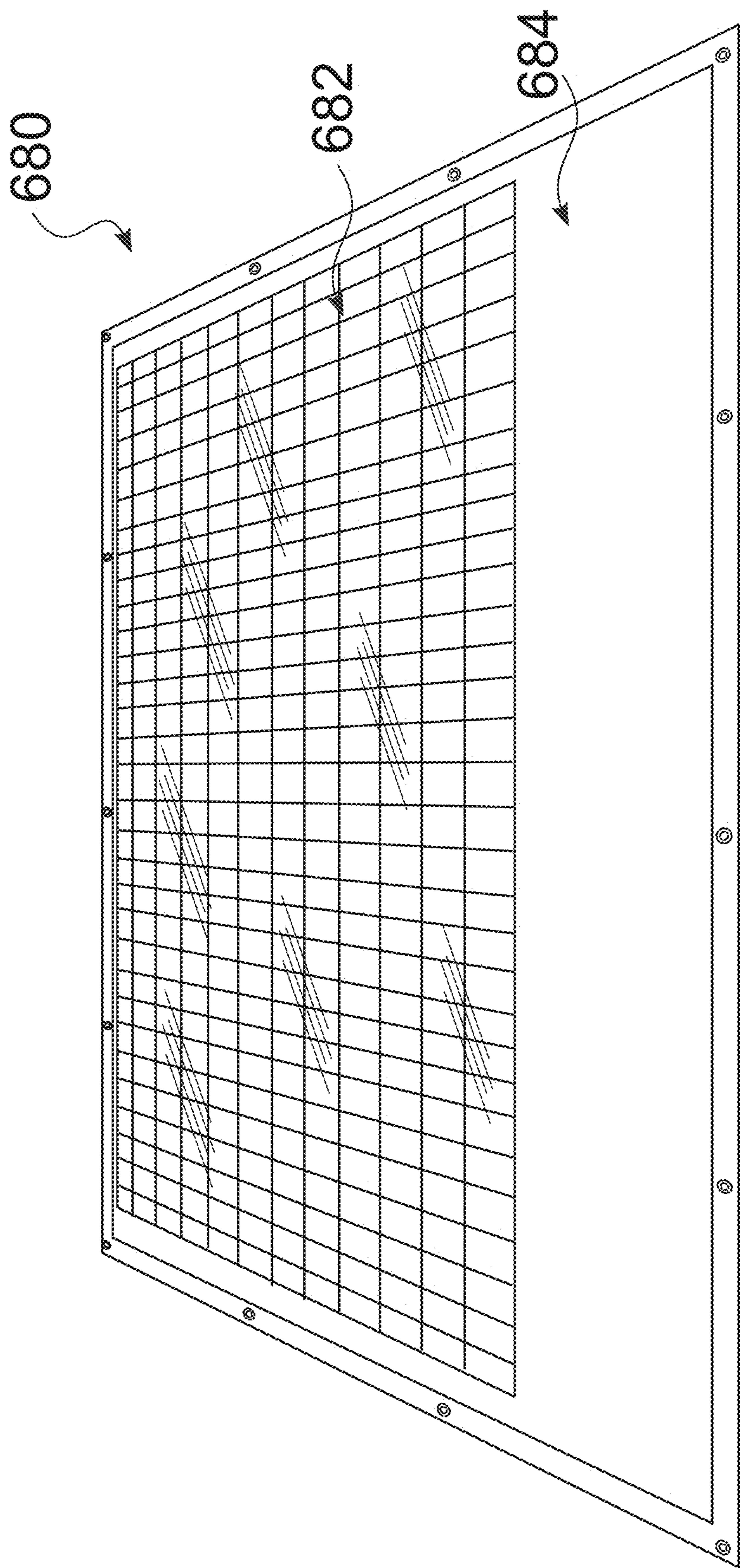

Fig. 30



149

Fig. 31

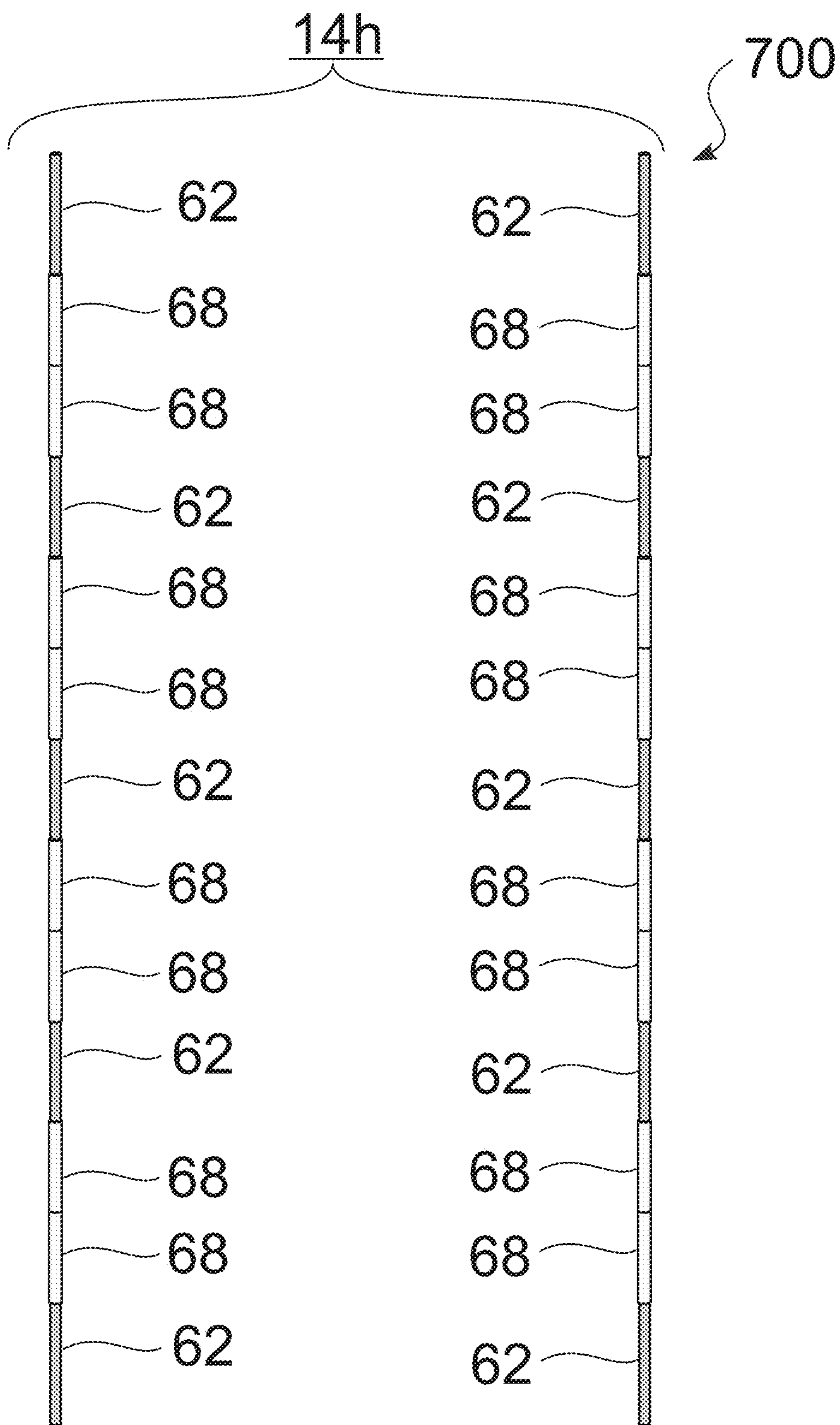

Fig. 32

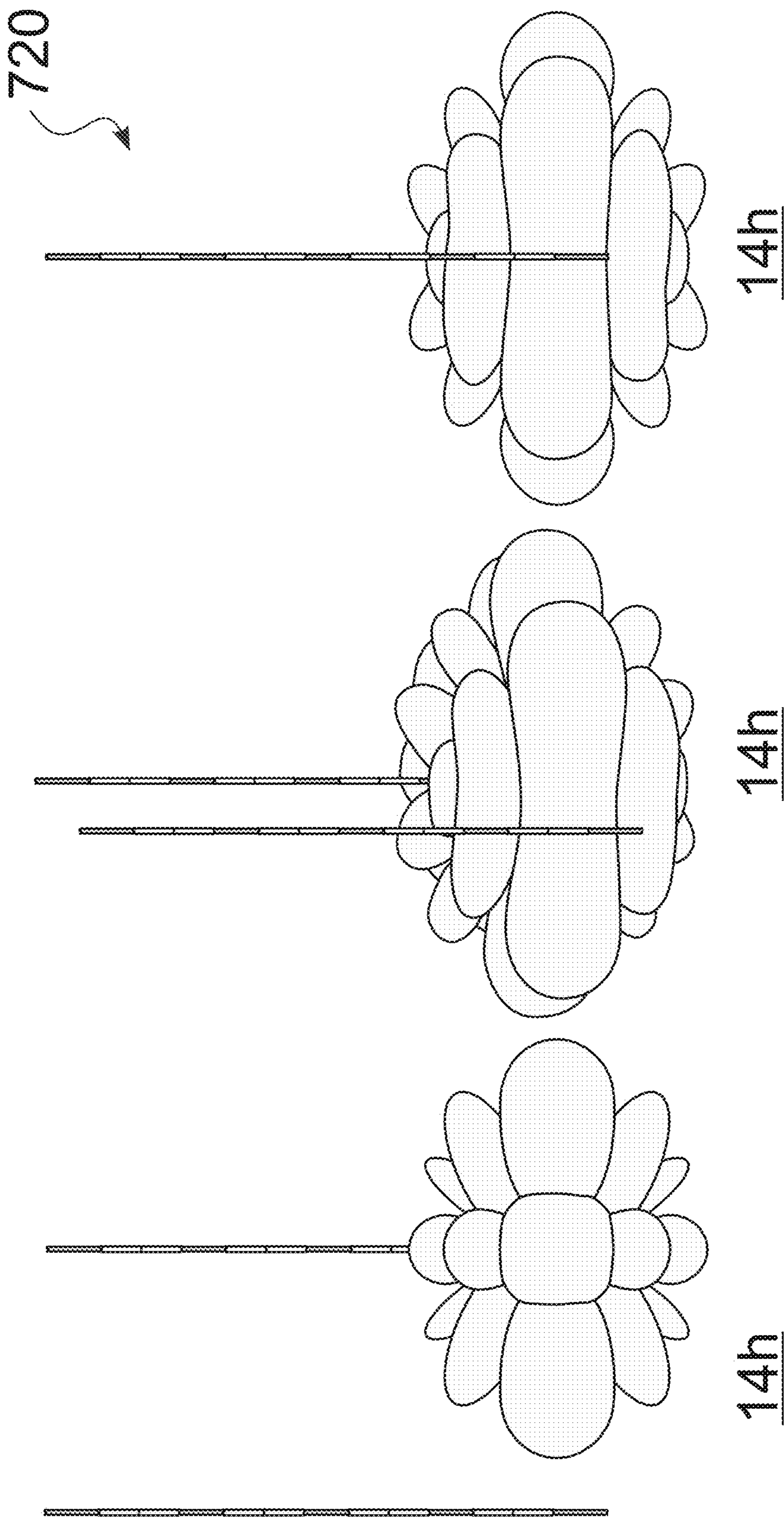

Fig. 33

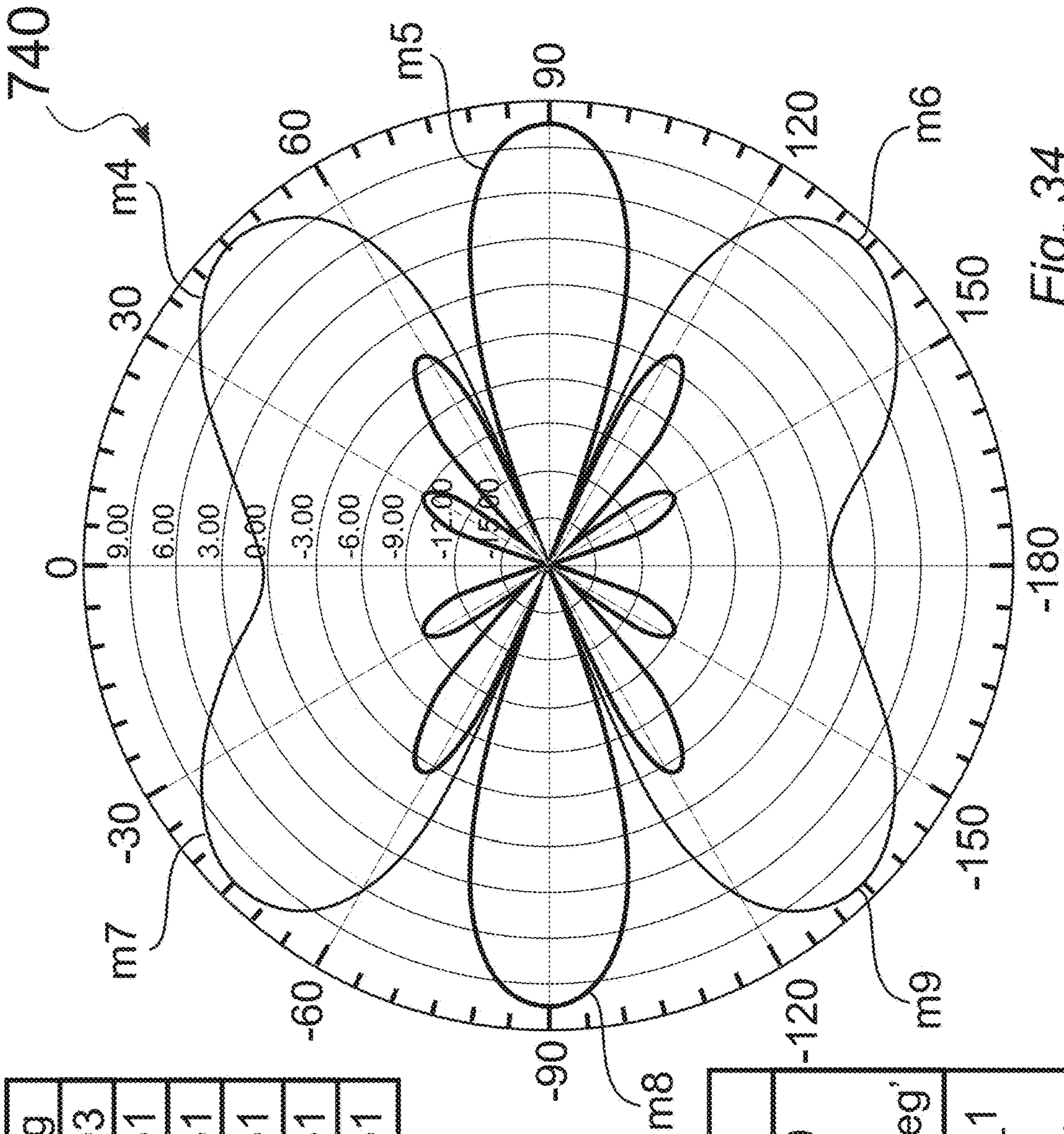

Fig. 34

Name	Phi	Ang	Mag
m4	45.00	45.00	10.93
m5	90.00	90.00	10.51
m6	135.00	135.00	10.51
m7	-46.00	-46.00	10.51
m8	-90.00	-90.00	10.51
m9	-135.00	-135.00	10.51

14h

Curve Info
— dB (Realized Gain Total) 400MHz: Last Adaptive Freq= '0.4GHz' Theta='90deg'
— dB (Realized Gain Total)_1 400MHz: Last Adaptive Freq= '0.4GHz' Phi='90deg'

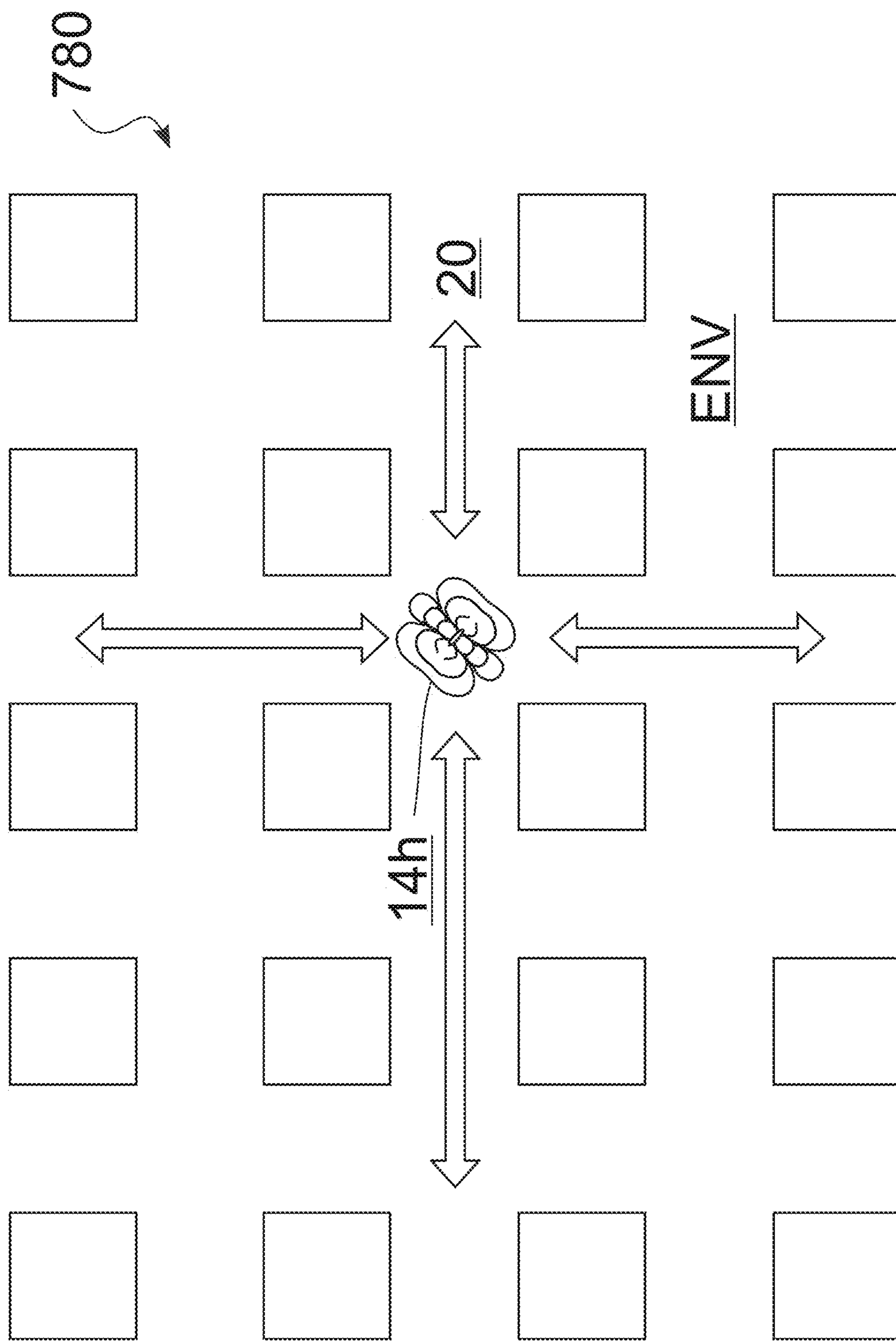

Fig. 35

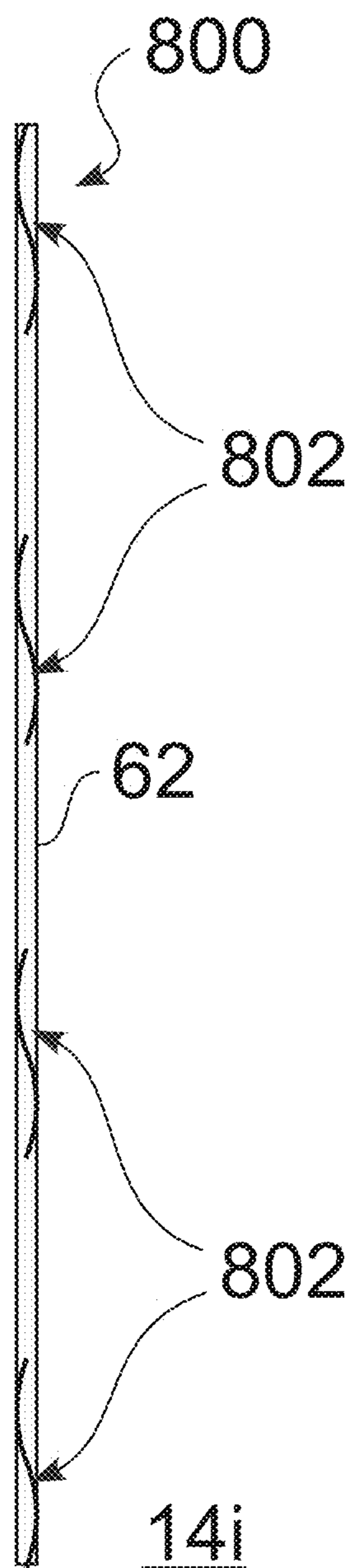

Fig. 36A

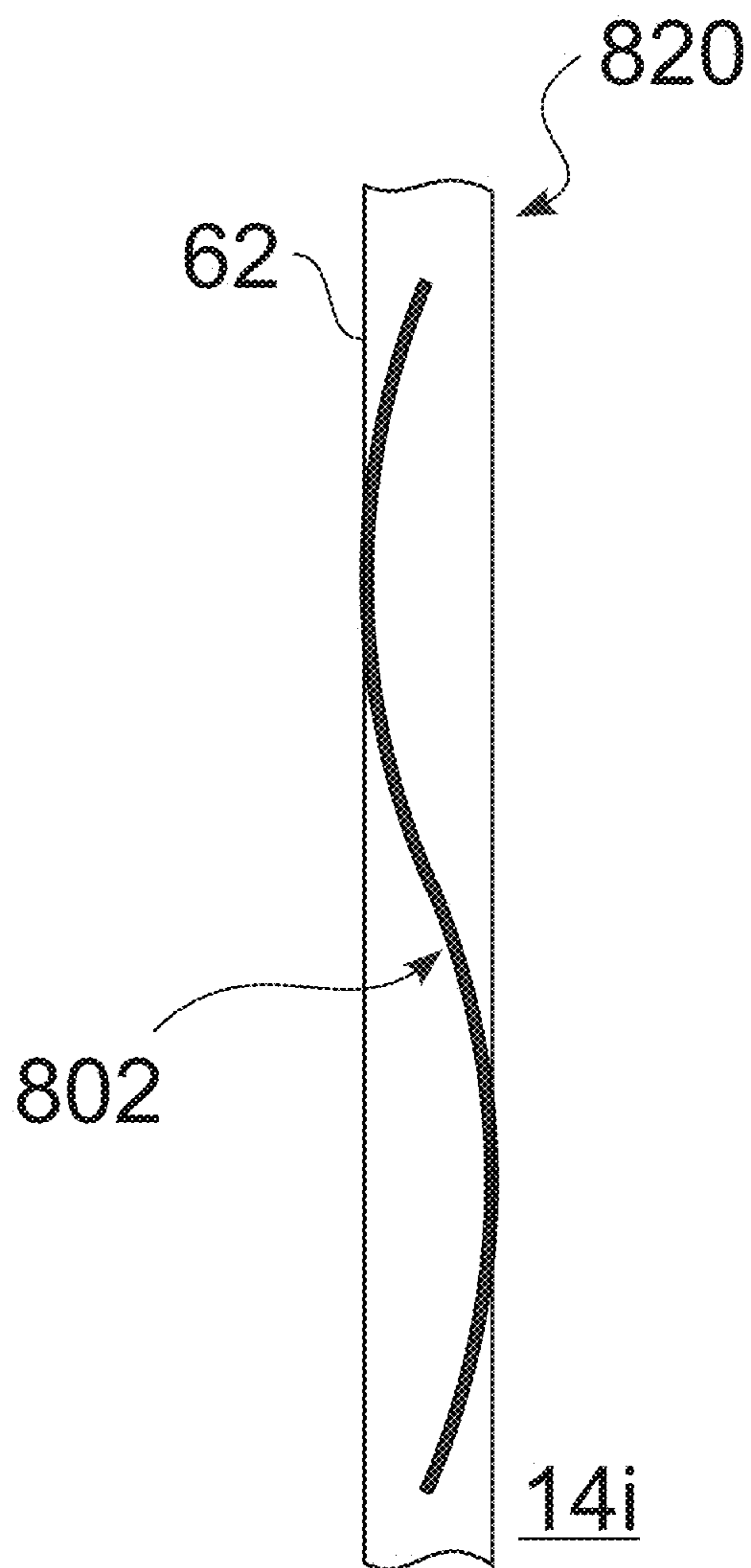
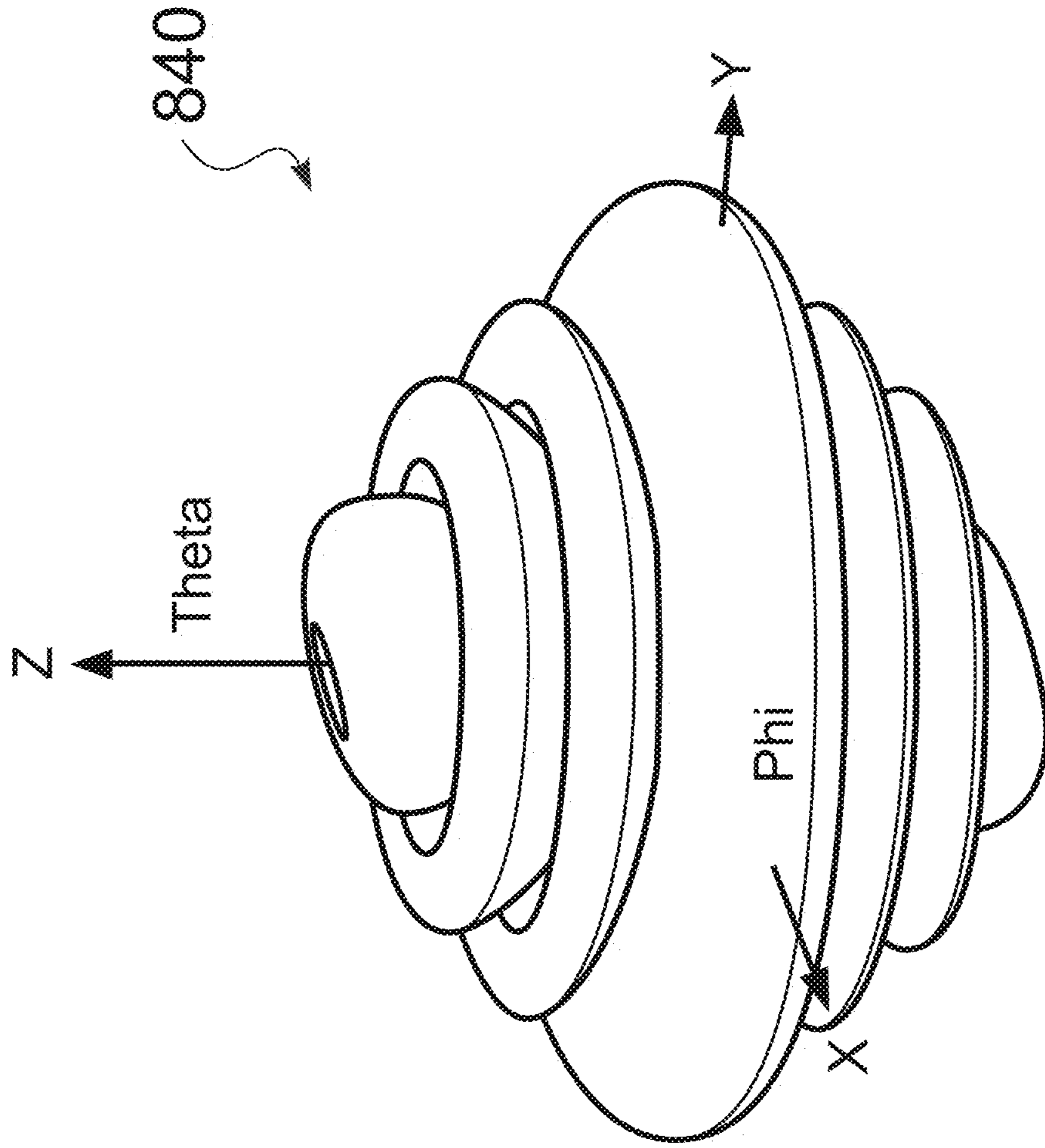

Fig. 36B



dB (RealizedGainTotal)	
	8.6172E+00
	4.0706E+00
	-4.7596E+01
	-5.0225E+00
	-9.5691E+01
	-1.4116E+01
	-1.8662E+01
	-2.3209E+01
	-3.2302E+01
	-3.6849E+01
	-1.9977E+01
	-4.1395E+01
	-4.5942E+01
	-5.0488E+01
	-5.5035E+01
	-5.9581E+01

Fig. 37

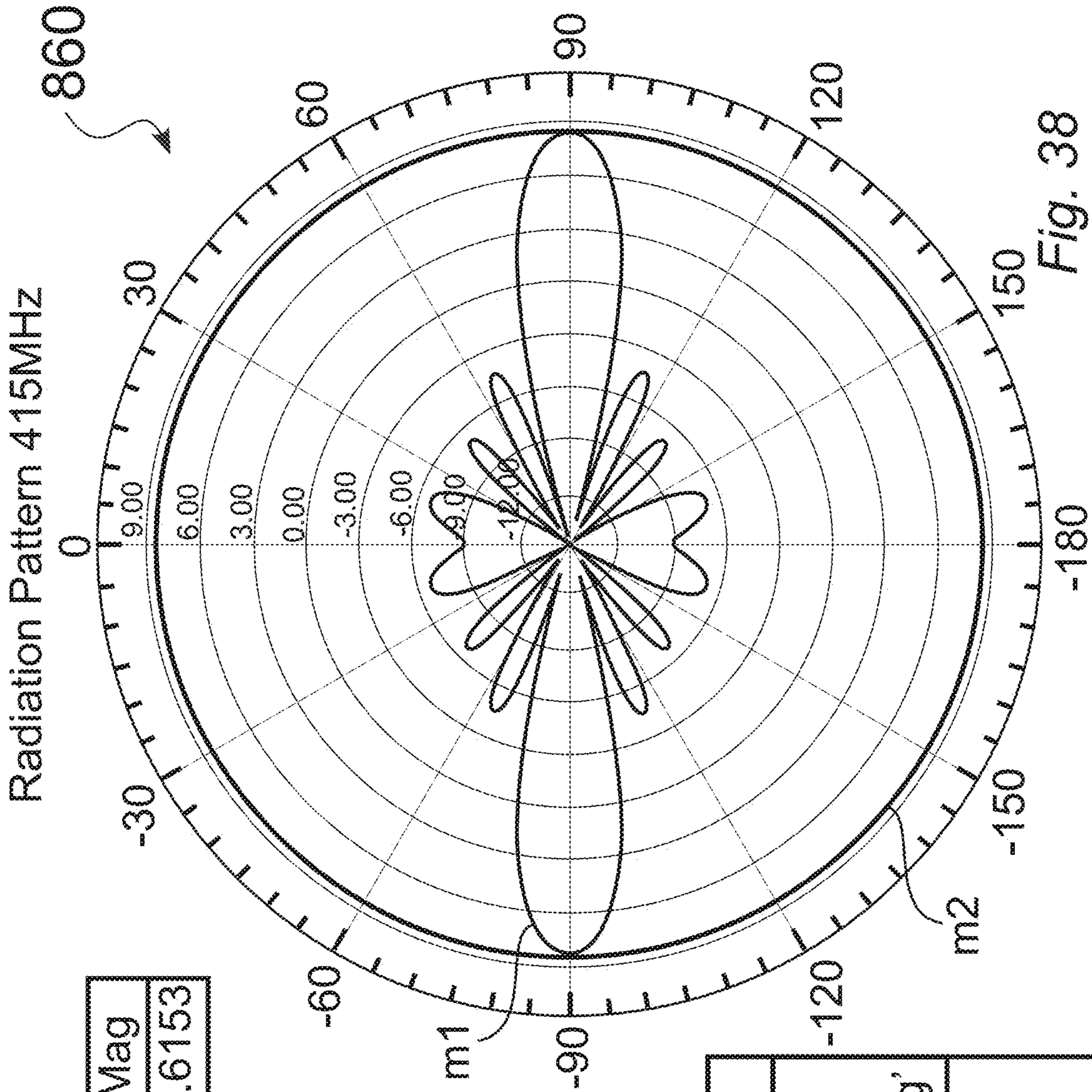

Fig. 38

Name	Phi	Ang	Mag
m1	45.0000	45.0000	8.6153

Curve Info	
—	dB (Realized Gain Total) Setup_400: Last Adaptive Freq= '416MHz' Theta='90deg'
—	dB (Realized Gain Total)_1 Setup_400: Last Adaptive Freq= '416MHz' Phi='0deg'

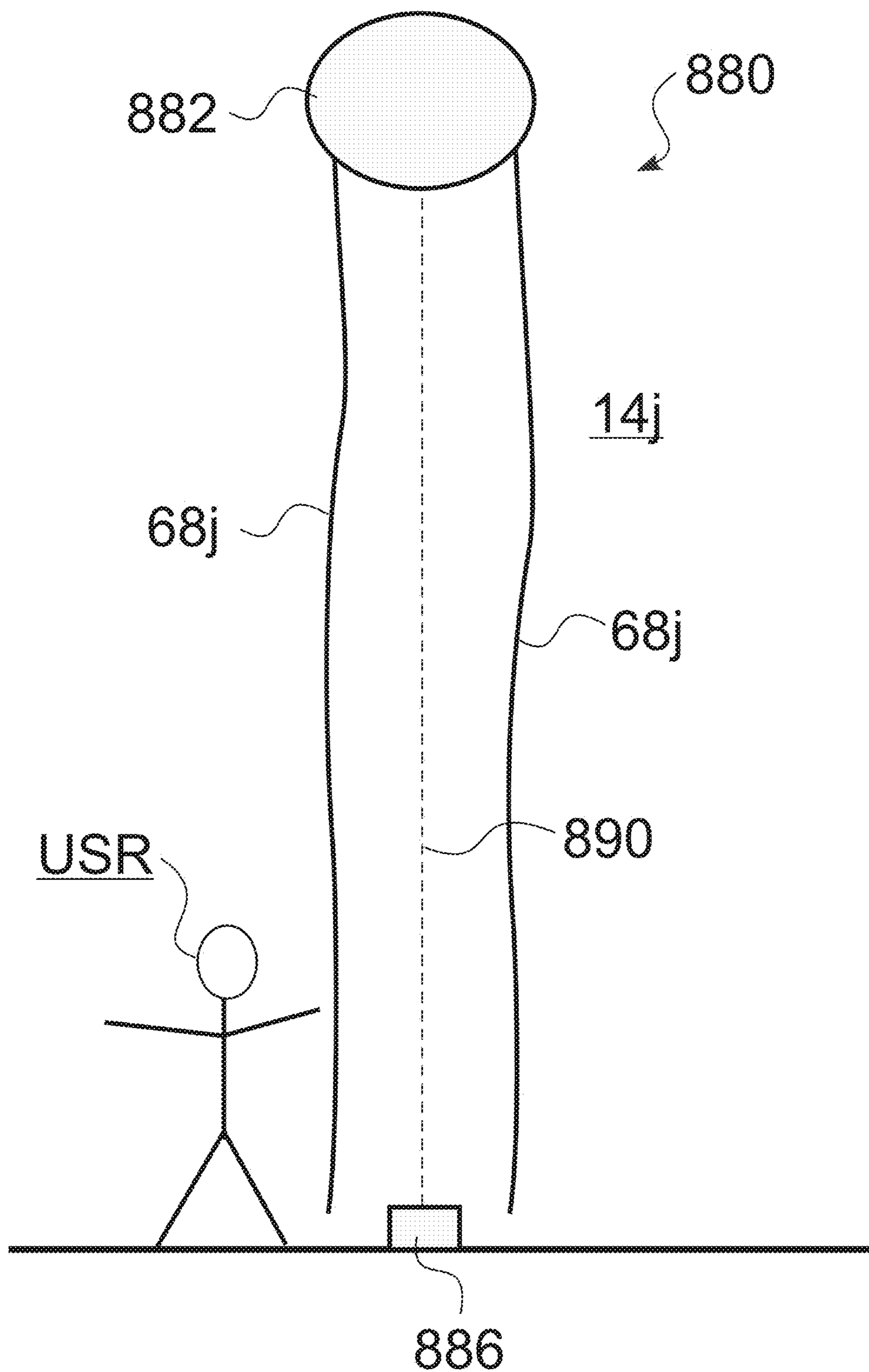
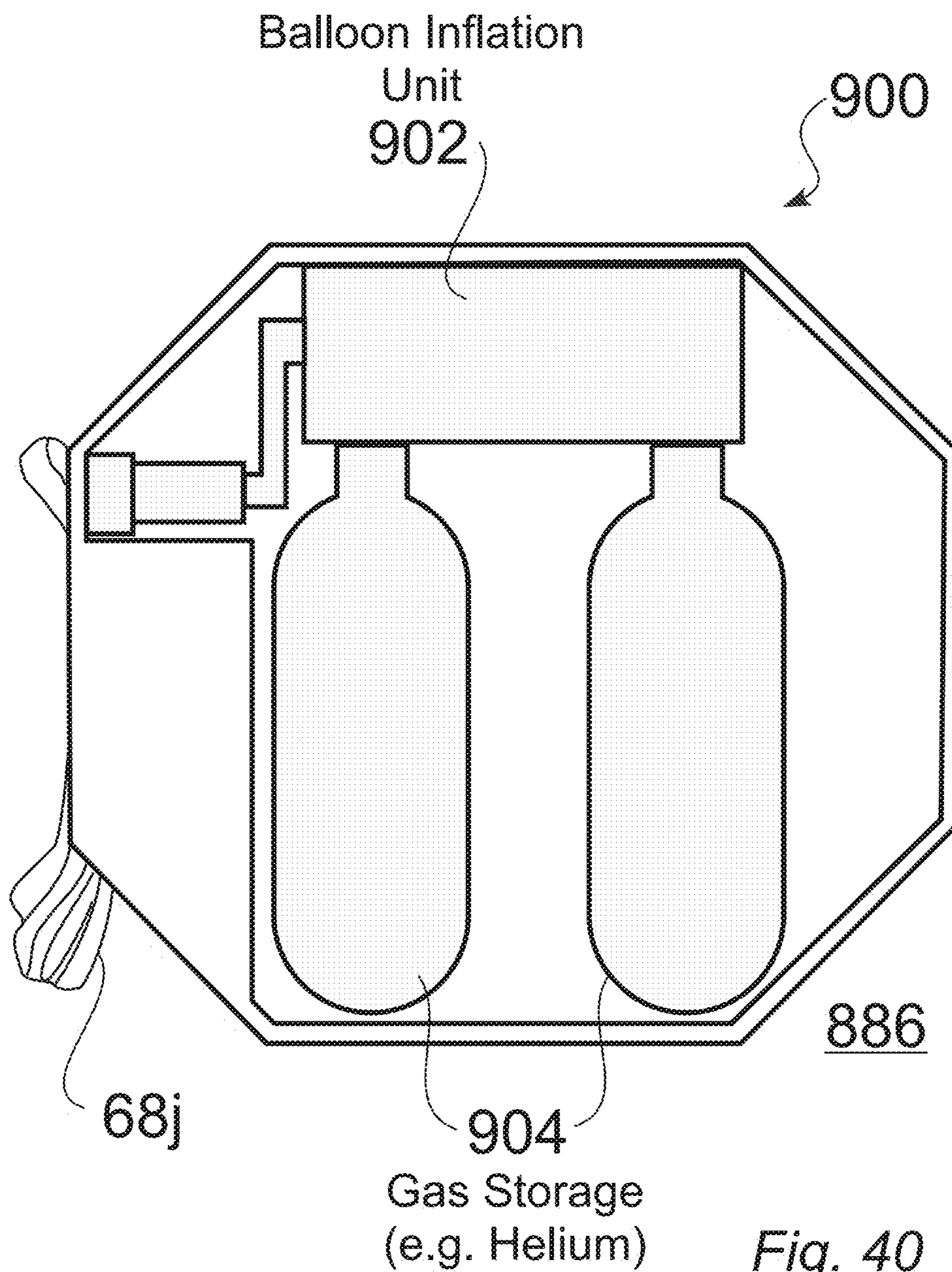

Fig. 39



**PORTABLE DEPLOYABLE UNDERGROUND
COMMUNICATION SYSTEMS, DEVICES
AND METHODS**

CROSS REFERENCE TO RELATED
APPLICATIONS

[0001] This application is a continuation of and claims priority to U.S. patent application Ser. No. 17/935,227, filed Sep. 26, 2022, which issued as U.S. Pat. No. XX,XXX,XXX on MONTH DAY YEAR, which is a continuation of and claims priority to U.S. Patent application Ser. No. 17/139,545, filed Dec. 31, 2020, which issued as U.S. Pat. No. 11,456,799 on Sep. 27, 2022, which is a continuation of and claims priority to U.S. patent application Ser. No. 16/730,300, filed Dec. 30, 2019, which issued as U.S. Pat. No. 10,887,000 on Jan. 5, 2021, which is a divisional of and claims priority to U.S. patent application Ser. No. 15/877,281, filed Jan. 22, 2018, which issued as U.S. Pat. No. 10,554,288 on Feb. 4, 2020, which is a continuation of and claims priority to U.S. patent application Ser. No. 15/439,761, filed Feb. 22, 2017, which issued as U.S. Pat. No. 9,876,556 on Jan. 23, 2018, which claims priority to U.S. Provisional Application No. 62/298,297, filed Feb. 22, 2016, which each is incorporated herein in their entirety by this reference thereto.

GOVERNMENT RIGHTS

[0002] This invention was made with government support under subcontract number SUB2015-AM-001-MIN awarded by prime contractor Robotic Research, LLC, under prime contract number W15QKN-14-C-0045 to the Defense Threat Reduction Agency (DTRA). The government has certain rights in the invention.

FIELD OF THE INVENTION

[0003] At least one embodiment of the present invention pertains to passive reflectors for wireless communication systems. More particularly, at least one embodiment of the present invention pertains to portable reflector components that can readily be positioned and deployed within a constrained environment, such as within an underground environment, to enable wireless communication between mobile radios.

BACKGROUND

[0004] Radio communications in underground and constrained environments such as mine tunnels is a complex challenge. The transmission of radio waves through the earth is limited due to severe attenuation of the signals, and most practical methods for communication use the tunnels themselves as paths for the radio waves. However, as radio waves travel in straight lines, and mine tunnels frequently change direction, curve, or intersect with other tunnels and shafts, it is necessary to install a complex infrastructure of radio equipment within mining tunnels to facilitate reliable communications between operators within the mine shaft and with personnel above ground.

[0005] Similar challenges and constraints occur in a variety of environments and situations. Cave exploration, as an example, is carried out in constrained conditions, with little or no knowledge of the terrain and the layout of underground pathways. In such applications, radio signals from an external source will have limited reach, such that repeaters are

often needed to ensure communications for the exploring party. In addition to underground complexes, challenging environments for radio communications exist in mountainous and canyon environments. In covert or military operations, there may be an existing radio communications infrastructure; however, it may be unavailable to the military team who may need to operate using different equipment and radio frequencies, as it is unlikely that they will have access to communications systems that may be controlled by potential adversaries.

[0006] Mining and underground tunnels are typically highly constrained in terms of space. It is thus valuable to have solutions that are compact or that otherwise take up little volume, especially within the pathways of the tunnels. Tunnels can extend to many kilometers underground, and all equipment must be transported to the installation location, often by operators traveling on foot or using very small vehicles. Equipment that is light and easy to transport is thus also valuable.

BRIEF DESCRIPTION OF THE DRAWINGS

[0007] One or more embodiments of the present invention are illustrated by way of example and not limitation in the figures of the accompanying drawings, in which like references indicate similar elements.

[0008] FIG. 1 is a schematic view of illustrative embodiment of a portable deployable underground communication system.

[0009] FIG. 2 is a flowchart of an illustrative process for deploying a portable underground communication system.

[0010] FIG. 3 shows an illustrative embodiment of a passive reflector element that includes a structural pole, and coaxially positioned reflectors.

[0011] FIG. 4 shows an illustrative embodiment of a storable passive reflector element in an undeployed state.

[0012] FIG. 5 shows a close-up view of reflector elements for an illustrative embodiment of a passive reflector element.

[0013] FIG. 6 shows a 3D radiation pattern image for an illustrative embodiment of a passive reflector element having a vertically-aligned structural pole and coaxially positioned reflectors, which provides 360 degree coverage in the horizontal plane.

[0014] FIG. 7 shows vertical and horizontal radiation patterns for an illustrative embodiment of a passive reflector element having a vertically-aligned structural pole and coaxially positioned reflectors.

[0015] FIG. 8 shows an illustrative embodiment of a passive reflector component having a structural pole with pairs of reflectors in the horizontal plane stacked on the vertical axis.

[0016] FIG. 9 shows a close up view of the reflector pair of the passive reflector component seen in FIG. 8.

[0017] FIG. 10 shows a 3D radiation pattern image for an illustrative embodiment of a passive reflector element having pairs of reflectors in the horizontal plane, which provides 360 degree coverage in the horizontal plane.

[0018] FIG. 11 shows vertical and horizontal radiation patterns for an illustrative embodiment of a passive reflector element having pairs of reflectors in the horizontal plane.

[0019] FIG. 12 shows an illustrative embodiment of a passive reflector component having a structural pole with horizontal reflectors and vertical reflectors.

[0020] FIG. 13 shows a close-up view of the reflector elements seen in FIG. 12.

[0021] FIG. 14 shows an alternative arrangement of a passive reflector component having a structural pole with horizontal reflectors and vertical reflectors.

[0022] FIG. 15 is a chart that shows vertical and horizontal radiation patterns for an illustrative embodiment of a passive reflector element having horizontal reflectors and vertical reflectors.

[0023] FIG. 16 shows an illustrative passive sheet reflector component that includes reflector elements arranged in a two-dimensional matrix.

[0024] FIG. 17 shows detailed view of a single-reflector element for an illustrative passive sheet reflector component.

[0025] FIG. 18 shows a prototype implementation of an illustrative passive sheet reflector component, including a structural sheet and a 4x4 matrix of copper tape reflector elements.

[0026] FIG. 19 shows a 3D radiation pattern image for an illustrative embodiment for one reflector element of a passive sheet reflector component.

[0027] FIG. 20 is a chart that shows vertical and horizontal radiation patterns for an illustrative embodiment of a passive sheet reflector component.

[0028] FIG. 21 shows an illustrative view and a 3D radiation pattern image for an alternate implementation of an illustrative embodiment for one reflector element of a passive sheet reflector component.

[0029] FIG. 22 is a chart that shows vertical and horizontal radiation patterns for an alternate implementation of an illustrative embodiment for one reflector element of a passive sheet reflector component.

[0030] FIG. 23 shows an illustrative view and a 3D radiation pattern image for a further implementation of an illustrative embodiment for one reflector element of a passive sheet reflector component.

[0031] FIG. 24 is a chart that shows vertical and horizontal radiation patterns for the implementation of an illustrative embodiment for one reflector element of a passive sheet reflector component shown in FIG. 23.

[0032] FIG. 25A and 25B provide a schematic front and rear views of reflector elements for an illustrative embodiment of patch antenna panels.

[0033] FIG. 26 shows an illustrative far field 3D radiation pattern for a corresponding patch antenna panel embodiment.

[0034] FIG. 27 is a chart that shows vertical and horizontal radiation patterns for an illustrative embodiment of patch antenna panels.

[0035] FIG. 28 shows conceptual 3D radiation patterns for two interconnected dual patch antenna panels.

[0036] FIG. 29 provides a schematic view of a passive reflector component that includes an inflatable puck having deployable structural elements and reflector elements.

[0037] FIG. 30 shows a plurality of inflatable pluck passive reflector components in their deployed state.

[0038] FIG. 31 provides a schematic view of a flat panel passive reflector component, using a metallized reflector element and a plastic tarpaulin structural element.

[0039] FIG. 32 provides a schematic view of dual pole passive reflector components, wherein each passive reflector component includes a structural pole with coaxially-positioned dual reflectors.

[0040] FIG. 33 shows 3D radiation patterns for one reflector element in a dual pole passive reflector.

[0041] FIG. 34 is a chart that shows vertical and horizontal radiation patterns for one reflector element of an illustrative dual pole reflector assembly.

[0042] FIG. 35 is a schematic diagram 780 for illustrative placement of a dual pole reflector assembly 14h in a tunnel network, which shows corresponding radiation patterns and preferred communication directions.

[0043] FIG. 36A and 36B are a schematic diagrams 800, 820 for illustrative helical wire reflector components.

[0044] FIG. 37 shows 3D radiation patterns for one helical wire reflector element associated with a helical wire reflector component.

[0045] FIG. 38 is a chart that shows vertical and horizontal radiation patterns for one helical wire reflector element associated with a helical wire reflector component.

[0046] FIG. 39 is a schematic diagram 880 of a deployed balloon reflector component in a tunnel network.

[0047] FIG. 40 is a schematic view of a deployment module for a balloon reflector component.

DETAILED DESCRIPTION

[0048] References in this description to “an embodiment”, “one embodiment”, or the like, mean that the particular feature, function, structure or characteristic being described is included in at least one embodiment of the present invention. Occurrences of such phrases in this specification do not necessarily all refer to the same embodiment. On the other hand, the embodiments referred to also are not necessarily mutually exclusive.

[0049] When radio communications reach the extent of their transmitted range, they may be propagated beyond their initial range through the use of repeaters. Repeaters use antenna reflector elements to receive the transmitted signal and retransmit it. Such retransmission may use the original frequency, signal direction, polarization, and other characteristics, or introduce changes in any or all of these aspects to meet the specific needs of a situation. Repeaters may be active, that is, using electric power to retransmit the received signal, or passive, retransmitting the received signal without the use of electric power. Repeaters are typically designed for specific frequency ranges of operation.

[0050] Existing solutions to the problem of radio communications in underground tunnel complexes typically use active repeaters placed at judicious intervals along the tunnels to repeaters require a power source, which must be provided either by electric wiring throughout the tunnel system or by batteries, which then must be monitored and replaced as necessary. Some attempts have been made to use simple passive reflectors, using square sheets of aluminum, in mines.

[0051] It is time-consuming and expensive to implement an electrical system in situations where there is an urgent need for communications in a constrained environment, for example during exploration of underground features such as caves and tunnels, in search and rescue operations in collapsed mines or buildings, and in military situations (especially covert military operations) where the surrounding infrastructure may not be in place or may not be accessible to the military users. In certain situations such as the initial exploration or surveying of a convoluted underground complex, it is not possible to implement an active repeater system prior to the survey.

[0052] Previous approaches to passive reflectors have been limited, using large flat sheets of aluminum positioned

at an angle of 45° to the incident radio wave, and were intended to provide a small extension in range in the context of intersecting cross cuts in mines or large corridors.

[0053] It would therefore be advantageous, in underground and constrained environments, to implement a portable, easily deployable, passive radio communications solution. Specifically it would be advantageous to implement portable, easily deployable, passive reflector systems, such as configured to operate in the ultra-high-frequency (UHF) band (300 MHz-3 GHz range), or in frequencies equal to or greater than the UHF band, e.g., such as up to 5 GHz.

[0054] Disclosed herein are portable, passive radio communications systems, components and related processes that can readily be deployed and used in underground and constrained environments. Certain embodiments provide portable, easily deployable, passive reflector systems, such as configured to operate in the ultra-high-frequency (UHF) band (300 MHz-3 GHz range) or at frequencies equal to or greater than the UHF band, e.g., such as up to 5 GHz.

[0055] The disclosed passive reflector radio communications system typically includes several novel aspects: patterned arrays of reflector elements, structural frameworks to support and orient the reflector elements within the array, methods for the calculation of reflector element and reflector element array size, shape, position, and orientation corresponding to a desired operational frequency, and deployment methods and devices to install embodiments of the invention at the desired location.

[0056] In some embodiments, reflector elements that are appropriate for the radio frequencies typically used in mining or other constrained environments can preferably be implemented.

[0057] For example, half-wavelength reflector elements can be used, subject to adjustment factors based on the material used in their construction and their size and thickness. The reflector elements can be any of structures such as rods or poles; shapes such as rectangular, square, or similar polygonal strips or panels; constructions such as woven or braided fibers, threads, or wires; and arrangements such as linear, two dimensional, or three-dimensional arrays; individually or in arrays of similar or dissimilar elements.

[0058] In some embodiments, the passive reflector elements are supported and can be positioned and oriented by a collapsible framework. The framework members can include spring-loaded struts, inflatable struts, flexible poles, hollow poles, inflatable tubes, foldable sheets, or collapsible ropes. The framework supports the reflector elements and orients it relative to the structure. While the structural framework in illustrative embodiments of the invention is intended to support and orient passive reflector elements, it can be readily envisioned to support and orient active reflector elements as well.

[0059] The structures, shapes, constructions, and arrangements of the reflector elements, their positions, and their material composition can be determined based on the desired operational frequencies and the specific propagation characteristics that are desired in the underground environment. For example, the specific embodiments described below use certain materials, dimensions, and positions that are the result of these considerations.

[0060] The passive reflector system can be placed in a folded or otherwise compact mode for transport into the tunnels. Once at the desired installation location, the system

can be installed and the reflector elements positioned appropriately for the radio frequencies used at the location.

[0061] FIG. 1 shows an illustrative view of a passive communication system 10, in which two users USR are considered using wireless devices 18, e.g., 18a, 18b, in an underground tunnel network ENV. The radio communications 20 emitted by the first user's wireless device 18a are propagated 20 using passive reflector elements 14, such as shown at successive locations 16a-16i through the tunnel ENV, so that the communication signals 20 are reflected from successive reflector elements 14, to reach the second user's device 18.

[0062] FIG. 2 is a flowchart of an illustrative process 40 for deploying a portable underground communication system 10. In the illustrative process seen in FIG. 2, constraints for deployment of a communication system 10 using passive reflector components 14 can be obtained 42, in which the constraints can include one or more available modes of transport for the components, such as to be carried by humans, pack animals, vehicles, and/or cable mechanisms. The specific passive reflector components 14 can also be selected 44 from an inventory of available components, such as based on any of identified constraints. The passive reflector components 14 are also typically required to be transported 46 through the constrained environment ENV. Before or at the time of deployment, the locations for deployment of the passive reflector components can be identified 48 and selected 50. Upon deployment 52 of the selected passive reflector components 14, the system 10 can be established or extended within the constrained environment.

Reflector Element and Array Design

[0063] Some embodiments of the illustrative reflector elements in the invention are designed using dipole design principles. A typical antenna dipole is constructed with two conductive segments. A feedpoint between the two conductive segments provides a signal for transmission in the case of a transmitting dipole antenna, and serves as a sink for the received signal in the case of a receiving dipole antenna. Dipoles are high-gain, omnidirectional antennas, and are well suited for use in collinear arrays—a stacked set of vertically aligned dipoles provides high gain in the horizontal plane.

[0064] To obtain such advantages with the use of reflector elements, some illustrative embodiments of the passive reflector components 14 adapt dipole design to that of the reflector, such as seen in FIG. 3. In a passive reflector system 10, the reflector 68 can be considered to be a dipole that is “fed” by an incident wave, and thus does not require a feedpoint to transmit. Further, the received signal 20 is not sunk into the feedpoint, but is instead reradiated. The ends of the dipole segments that would normally be connected to the feedpoint can be connected to each other for simplicity. This approach to reflector element design has advantages in design and construction, and provides a wider bandwidth, especially in higher harmonics. The resulting reflector elements 68 can be stacked, and arranged in collinear arrays 66, such as seen in FIG. 3, for improved gain and directionality due to the interaction between the reradiation patterns from the different elements 68 in the array 66.

Foldable Pole Reflector Component Having Vertical Reflector Elements

[0065] FIG. 3 shows an illustrative embodiment of a passive reflector components **14a** that includes a structural pole **62**, and coaxially positioned reflectors **68**. FIG. 4 shows an illustrative embodiment of a storable passive reflector component **14a** in an undeployed state. FIG. 5 shows a close-up view of reflector elements **68** for an illustrative embodiment of a passive reflector component **14a**.

[0066] In this embodiment, the structural framework for the passive reflector solution is a foldable pole arrangement, using hollow poles **82** and mating ferrules **84**, in which the hollow poles **82** can be made of a suitable dielectric material such as fiberglass. In some embodiments **14a**, an elastic cord **86** is run through the hollow fiberglass poles **82**, serving as a tensioning mechanism. The tubes **82** can be collapsed and folded, as seen in FIG. 4, for transport and storage, and installed at the location by interconnecting **88** the pole segments **82**.

[0067] The reflector elements **68** seen in FIGS. 3-5 are vertically positioned along the axis of the structural pole **62**. In some embodiments, the reflector elements **68** are preferably hollow cylindrical tubes constructed of a metal, e.g., aluminum, and placed coaxially and around the structural pole **62**. Alternatively, the reflector elements **68** can be constructed using metal or metalized tape affixed around a hollow tube **62** of any of a variety of materials.

[0068] The reflector elements **68** can be stacked on the pole **62** as shown in FIG. 3, with an appropriate spacing between them. The length of the reflector elements **68** can be selected to provide resonance at the desired frequency of operation. In some embodiments, the length can preferably approximate half the wavelength (0.5λ) of the signal, as adjusted by an appropriate adjustment factor corresponding to the material of the reflector and its size and thickness. The distance from the center of one reflector **68** element to the center of the next reflector **68** can preferably correspond to approximately 0.75λ adjusted as above.

[0069] As an example, a specific implementation of a passive reflector component **14a** includes eight aluminum reflector elements **68**, fiberglass support poles **62**, and can further include an aluminum support base **70**.

[0070] In some embodiments of the reflector component **14a** seen in FIGS. 3-5, to support an illustrative UHF radio frequency of 400 MHz, the length of each reflector element **68** can be optimized to be 13.1" for resonance, using a 0.5λ length, adjusted by an adjustment factor of 0.888. The center-to-center distance between two adjacent reflectors **68** can be optimized to 20.1", or 0.75λ using the same adjustment factor. This arrangement provides a total maximum gain of 10.3 dBi. In such an illustrative embodiment, the antenna dimensions including the support structure are 0.625"×0.625"×198.3" (16.5').

[0071] In some embodiments of the reflector component **14a** seen in FIGS. 3-5, the reflector component **14a** can be placed on the ground within a constrained environment ENV, taking up little space in the tunnel, or, alternatively, mounted on a wall. In some embodiments of the reflector component **14a**, the reflector elements **68** are cylindrical so that the signal **20** will be reflected uniformly through all 360 degrees of the horizontal plane, providing coverage in all directions.

[0072] FIG. 6 shows a 3D radiation pattern image **120** for an illustrative embodiment of a passive reflector element

14a having a vertically-aligned structural pole **62** and coaxially positioned reflectors **68**, which provides 360 degree coverage in the horizontal plane. FIG. 7 shows **140** vertical and horizontal radiation patterns **m1** and **m2** for an illustrative embodiment of a passive reflector element **14a** having a vertically-aligned structural pole **62** and coaxially positioned reflectors **68**.

[0073] In some alternate embodiments of the passive reflector element **14a**, each reflector element **68** can be flat and oriented at a different angle, instead of cylindrical. This arrangement allows each reflector **68** to be directional, and the embodiment can provide a broad range of reflection angles.

Passive Reflector Components Foldable Pole, With Horizontal Reflector Elements

[0074] FIG. 8 shows an illustrative embodiment **160** of a passive reflector component **14b** having a structural pole **62** with pairs of reflectors **68b** in the horizontal plane stacked on the vertical axis Z. FIG. 9 shows a close up view **180** of a illustrative reflector pair **182**, e.g. **182a**, **182b**, of the passive reflector component **14b** seen in FIG. 8.

[0075] In the illustrative passive reflector component **14b** seen in FIG. 8 and FIG. 9, the structural framework **62** for the passive reflector component **14b** can be configured as a foldable pole **62**, such as discussed above for passive reflector component **14a**, using hollow poles made of a suitable dielectric material, e.g., fiberglass. As discussed above, in some embodiments **14b**, an elastic cord **86** can extend through mating fiberglass tubes **82**, serving as a tensioning mechanism. In this manner, the tubes **82** can be collapsed and folded (FIG. 4) for transport and storage, and assembled **88** installed at the location ENV by interconnecting the pole segments **82**.

[0076] The reflector elements **68b** are vertically positioned along the axis Z **184z** (FIG. 9) of the structural pole. In some embodiments, each reflector element **68b** includes a pair of crossed metal rods, intersecting at an angle of 90° . In some embodiments of the illustrative passive reflector component **14b** seen in FIG. 8 and FIG. 9, the reflector elements **68b** can preferably be constructed of a metal, e.g., aluminum. The reflector elements are stacked on the pole **62**, with an appropriate spacing between them. In some embodiments, each of the cross-shaped reflector elements **68b** are aligned in the horizontal plane and are placed perpendicular to the axis Z **184z** of the structural pole **62**. The size, shape, spacing, and grouping of the reflector elements **68b** can be configured to provide desired reflectivity characteristics for the frequencies involved, i.e., optimized for UHF frequencies of higher than UHF frequencies, e.g., such as but not limited to 2.4 Ghz or 5 Ghz operation.

[0077] The length of the reflector elements **68b** can be selected to provide resonance at the desired frequency of operation. In some embodiments, the length can preferably approximate half the wavelength (0.5λ) of the signal **20**, as adjusted by an appropriate adjustment factor corresponding to the material of the reflector **68b** and its size and thickness. In some embodiments of the reflector elements **68b**, the vertical distance from one pair of reflector elements **68** to the next pair **68b** corresponds to approximately 0.75λ , adjusted as above.

[0078] An illustrative implementation of the passive reflector component **14b** seen in FIG. 8 and FIG. 9 uses sixteen aluminum reflector elements **68b** arranged in eight

crossed pairs **182a**, **182b**, aligned in the horizontal plane, fiberglass support poles **62**, and can include an aluminum support base **70** (FIG. 3). To support an illustrative UHF radio frequency of 400 MHz, the reflector element length can be optimized to be 13.8" for resonance, using a 0.5λ length, adjusted by an adjustment factor of 0.935. The vertical distance between two adjacent reflector crossed pairs can be optimized to 20.7", or 0.75λ using the same adjustment factor. This arrangement provides a total maximum gain of 10.9 dBi. In an illustrative embodiment, the antenna dimensions including the support structure are 13.8"×13.8"×180.9" (15'). In some embodiments of the reflector component **14b** seen in FIGS. 8 and 9, the reflector component **14b** can be placed vertically on the ground within a constrained environment ENV, such as within a tunnel, resulting in a small footprint.

[0079] FIG. 10 shows a 3D radiation pattern image **200** for an illustrative embodiment of a passive reflector element **14b** having pairs of reflectors **68b** in the horizontal plane, which provides 360 degree coverage in the horizontal plane. FIG. 11 is a chart **220** showing illustrative vertical and horizontal radiation patterns **m1** and **m2** for an illustrative embodiment of a passive reflector element **68b** having pairs of reflectors in the horizontal plane. The reflector elements **68b** reflect the signal through a 360-degree arc in the horizontal plane with a slightly higher gain in the 45° - 135° axis, providing relatively uniform coverage in all directions.

Passive Reflector Component Having Horizontal and Vertical Reflectors

[0080] FIG. 12 shows **240** an illustrative embodiment of a passive reflector component **14c** having a structural pole **62** that includes a combination **68c** of horizontal reflectors and vertical reflectors. FIG. 13 shows a close-up view **260** of the reflector elements seen in FIG. 12. FIG. 14 shows an alternative arrangement **280** of a passive reflector component **68c** having a structural pole with horizontal reflectors and vertical reflectors.

[0081] The illustrative passive reflector components **14c** seen in FIGS. 12-14 can be configured as a combination of passive reflector components **14a** and **14b**. The structural framework for the passive reflector **14c** can be a foldable pole arrangement, such as seen in FIG. 4, such as using hollow poles **82** made of a suitable dielectric material such as fiberglass. In an illustrative embodiment, an elastic cord **86** is run through the fiberglass tubes **82**, serving as a tensioning mechanism. The tubes **82** can be collapsed and folded for transport and storage, and installed at the location by interconnecting the pole segments **82**.

[0082] The reflector elements **68c** are vertically positioned along the axis of the structural pole **62**. In the reflector elements **68c** seen in FIGS. 12-14, both horizontally-aligned reflector elements **264** and vertically-aligned reflector elements **262** are used.

[0083] The horizontally aligned reflector elements **264** can be arranged as a pair of crossed metal rods, intersecting at an angle of 90° . In some embodiments, the reflector elements **262** and/or **264** can preferably be constructed of a metal such as aluminum. The reflector elements **68c** are stacked on the pole as shown in FIG. 12, with an appropriate spacing between them. Each of the cross-shaped reflector elements **264** is aligned in the horizontal plane, and is placed perpendicular to the axis Z of the structural pole **62**. The size, shape, spacing, and grouping of the reflector elements

262, **264** are configured to provide the desired reflectivity characteristics for the frequencies involved, e.g., UHF or greater than UHF frequencies.

[0084] The horizontally aligned reflector elements **262** are combined with vertical reflector elements **264** that are positioned along the axis Z of the structural pole **62**. In some embodiments, the vertical reflector elements **262** can include hollow cylindrical tubes constructed of a metal, e.g., aluminum, and placed coaxially and around the structural pole **62**. Alternatively, the reflector elements **68c** can be constructed using metal or metalized tape affixed around a hollow tube of any of a variety of materials.

[0085] The lengths of the reflector elements **68v** can be selected to provide resonance at the desired frequency of operation. In some embodiments, the length can approximate half the wavelength (0.5λ) of the signal, as adjusted by an appropriate adjustment factor corresponding to the material of the reflector and its size and thickness. In some embodiments, the vertical distance from one pair of reflector elements to the next pair can correspond to approximately 0.75λ adjusted as above.

[0086] An alternative implementation **14c** includes horizontal **264** and vertical **262** reflector elements, as illustrated in FIG. 14, wherein the vertical elements **262** are positioned between the horizontal elements **264** instead of being intersected by them.

[0087] In a specific illustrative embodiment, the passive reflector component **14c** includes **24** conductive reflector elements with **16** reflector elements arranged horizontally in eight crossed pairs **264** aligned in the horizontal plane, **8** reflector elements **262** arranged vertically along the Z axis of the structural framework, **8** dielectric support rods **82** (FIG. 4) made of fiberglass, a dielectric support pole to the base, and an aluminum support base **70** (FIG. 3).

[0088] This implementation uses tubular (hollow) $\frac{1}{2}$ " outer diameter fiberglass rods **82** that provide support for the $\frac{5}{8}$ " outer diameter aluminum vertical elements and at the same time dielectrically load the vertical array. This loading provides for shorter vertical element to vertical element spacing (7" end to end at 400 MHz) making the entire array shorter and more compact. The hollow fiberglass rods **82** allow for an elastic shock cord **86** (FIG. 4) to extend through the entire array, providing needed tension for the structure **14c**, as well as ease of packing when stowed. In an illustrative embodiment, an exemplary elastic shock cord **86** for stowable embodiments **14** can be Series No. SC Nylon Shock Cord, such as currently available through T. W. Evans Cordage Co., of Cranston RI.

[0089] To support an illustrative UHF radio frequency of 400 MHz, the reflector element length in the implementation of FIG. 11 can be optimized for resonance to be 13.8" (horizontal), using a 0.5λ length, adjusted by an adjustment factor of 0.935, and 13.1" (vertical) using an adjustment factor of 0.888. The vertical distance between two adjacent reflector crossed pairs can be optimized to 20.1", or 0.75λ using the same vertical adjustment factor. This arrangement provides a total maximum gain of 11.9 dBi.

[0090] The antenna dimensions including the support structure are 13.8"×13.8"×198.3. In some embodiments of the reflector component **14c** seen in FIGS. 12-14, the reflector component **14c** can be placed vertically on the ground within a constrained environment ENV, such as within a tunnel, resulting in a small footprint.

[0091] FIG. 15 is a chart 300 that shows radiation patterns for vertical m1 and horizontal m2 radiation patterns for an illustrative embodiment of a passive reflector element having horizontal reflectors and vertical reflectors. The reflector elements of a passive reflector element 14c reflect the signal through a 360-degree arc in the horizontal plane with a slightly higher gain in the $-45^{\circ}/135^{\circ}$ axis, providing relatively uniform coverage in all directions.

Passive Sheet Reflector Components

[0092] FIG. 16 shows 320 an illustrative passive sheet reflector component 14d that includes reflector elements 68d arranged in a two-dimensional matrix 322, such as embedded within a flexible sheet backing 362. FIG. 17 shows detailed view 340 of a single-reflector element 68d for an illustrative passive sheet reflector component 14d. FIG. 18 shows 360 a prototype implementation of an illustrative passive sheet reflector component 14d, including a structural sheet 362 and a 4x4 matrix of copper tape reflector elements 68d.

[0093] In the passive sheet reflector component 14d seen in FIGS. 16-18, the structural framework for the passive UHF reflector component 14d can be a flat sheet 362, such as a blanket or a tarpaulin made of a suitable dielectric material. The sheet 362 can be folded or rolled into a compact size and shape for ease of transport, and unfolded at the desired installation site.

[0094] The reflector elements 68d can be placed in a two-dimensional planar arrangement 322 across the surface of the structural sheet, as shown in FIG. 16. Each reflector element 68d seen in FIG. 16 is a rectangular strip of metal tape affixed to the sheet 362 at a specific location such as shown in FIG. 17. The size, shape, spacing, and grouping of the reflector elements 68d are designed to provide the desired reflectivity characteristics for the frequencies involved, e.g., UHF or greater than UHF. The length of the reflector elements 68d can be selected to provide resonance at the desired frequency of operation. In some embodiments, the length can approximate half the wavelength (0.5λ) of the signal, as adjusted by an appropriate adjustment factor corresponding to the material of the reflector 68d and its size and thickness.

[0095] An illustrative embodiment 14d, such as seen in FIG. 16, includes sixteen conductive elements 68d made of copper tape arranged in a 4x4 rectangular matrix 322, and a plastic tarpaulin as a structural sheet 362 (FIG. 18). To support a desired UHF radio frequency of 400 MHz, the reflector element length can be optimized to be 13.5" for resonance, using a 0.5λ length, adjusted by an adjustment factor of 0.915. In the illustrative embodiment shown in FIGS. 16 and 17, the width of the reflector element 68d is 3". The horizontal and vertical distances between two adjacent reflectors can be optimized to 28.5" and 12" respectively. This arrangement provides a total maximum gain of 14 dBi. The total antenna dimensions not including the support structure are approximately 4' by 9'. An illustrative passive sheet reflector component 14d can be placed on a wall or suspended as shown in FIG. 18.

[0096] FIG. 19 shows 380 a 3D radiation pattern image 382 for an illustrative embodiment for one reflector element of a passive sheet reflector component 14d. FIG. 20 is a chart 400 that shows vertical and horizontal radiation patterns m1, m2 for a UHF signal 20 in an illustrative embodiment of a passive sheet reflector component 14d.

[0097] FIG. 21 provides a schematic view 420 of an alternate passive sheet reflector component 14d, and shows a 3D radiation pattern image for a corresponding reflector element 68d. FIG. 22 is a chart that shows vertical and horizontal radiation patterns for a reflector element of the alternate passive sheet reflector component 14d shown in FIG. 21. The alternate passive sheet reflector component 14d includes sixteen conductive elements 68d made of copper tape arranged in a 4x4 rectangular matrix, and a plastic tarpaulin 362 as a structural sheet. To support an illustrative UHF radio frequency of 400 MHz, the reflector element length can be optimized to be 13.5" for resonance, using a 0.5λ length, adjusted by an adjustment factor of 0.915. The width of the reflector element is 1". The horizontal and vertical distances between two adjacent reflectors 68d can be optimized to 21.5" and 13" respectively. This arrangement provides a total maximum gain of 17.5 dBi. The total antenna dimensions not including the support structure are 93"x68.5"x0.01". The alternate passive sheet reflector component 14d provides greater directionality and gain, as shown by the radiation patterns in FIG. 21 and FIG. 22.

[0098] A further implementation of a passive sheet reflector component 14d, as shown in FIGS. 23 and 24, includes twelve conductive elements 68b made of copper tape arranged in a 3x4 rectangular matrix, and a plastic tarpaulin 362 as a structural sheet. To support an illustrative UHF radio frequency of 400 MHz, the reflector element length can be optimized to be 13.5" for resonance, using a 0.5λ length, adjusted by an adjustment factor of 0.915. The width of the reflector element is 1". The horizontal and vertical distances between two adjacent reflectors 68d can be optimized to 21.5" and 13" respectively. This arrangement provides a total maximum gain of 15.9 dBi. The total antenna dimensions not including the support structure are 66.5"x68.5"x0.01". The illustrative passive sheet reflector component 14d shown in FIGS. 23 and 24 provides greater directionality and gain, as shown by the radiation patterns.

Passive Reflector Components Having Patch Antenna Panels With Ground Plane

[0099] FIG. 25A and 25B provide schematic front 500 and rear views 520 of reflector elements for an illustrative embodiment of patch antenna panels 14e. FIG. 26 shows an illustrative far field 3D radiation pattern 540 for a corresponding patch antenna panel embodiment 14e. FIG. 27 is a chart 560 that shows vertical and horizontal radiation patterns for an illustrative embodiment of patch antenna panels 14e. FIG. 28 shows conceptual 3D radiation patterns 580 for two interconnected dual patch antenna panels 14e.

[0100] In an illustrative embodiment of the patch antenna panels 14e, the structural framework can include a flat sheet 502 of compressible air foam material, which in some embodiments can have characteristic thickness of 0.25". In some embodiments, the reflector elements 68e are configured as a conductive ground plane on one side of the structural framework 502, which in some embodiments is preferably copper foil, and two patch elements 68e on the other side of the structural framework 502, which in some embodiments can also preferably include copper foil.

[0101] The two dimensional nature of this planar array 14e results in a versatile structure which is able to provide a high-gain radiation pattern with a strong front lobe and weak side lobes. In some embodiments, the patch antenna panels

14e can be rolled up and stored in a lightweight tube, allowing easy transport and deployment.

[0102] In an illustrative implementation of the patch antenna panels **14e**, each dual patch panel is 49"×36", made of 8 mil copper foil on a 0.25" foam substrate as the structural element, with a ground plane also of 8 mil copper foil. FIG. 26 and FIG. 27 show the radiation pattern for one patch panel with its corresponding ground plane. This arrangement provides the widest gain with deep pattern nulls at +90° and -90°. FIG. 28 shows illustrative radiation patterns for two dual patch antenna panels **14e**, when their corresponding ground planes are interconnected.

[0103] Some alternate embodiments of the passive reflector components **14** can include structural framework comprising a flat sheet, such as made by weaving a suitable fiber such as Kevlar into a mesh sheet. In some mesh embodiments, the reflective elements can include metal or metalized fibers that are woven into the mesh. The size, shape, spacing, and grouping of the woven metal wires can be configured to provide the desired reflectivity characteristics for the UHF frequencies involved, e.g., UHF or greater than UHF. In one variation, the arrangement of the reflector elements can be in a 4×4 matrix of the rectangular reflector elements **68**, in a manner similar to that of sheet embodiments **14d**, which can be hung or be placed on a wall.

[0104] Other embodiments of the passive reflector components **14** can include a structural framework provided by a rope made of a suitable material, such as Kevlar™ or fiberglass. In an illustrative embodiment, the reflector elements are metal or metalized wires that can be introduced among the fibers to provide a preferred arrangement of reflector elements. The size, shape, spacing, and grouping of the metal wires within the rope are designed to provide the desired reflectivity characteristics for the UHF frequencies involved, e.g., UHF or greater than UHF. In such an embodiment, the wire mesh rope reflector component **14** can be hung from the ceiling of the tunnel ENV, potentially allowing it to be out of the way and be less prone to damage from collisions with vehicles or people traveling through the tunnel.

Passive Reflector Components With Inflatable Puck

[0105] FIG. 29 provides a schematic view **600** of a passive reflector component **14f** that includes an inflatable puck **602** having deployable structural elements **606** and reflector elements **68f**. When deployed (FIG. 3), the flexible membrane **610** can be inflated to its full height. FIG. 30 shows **610** a plurality of inflatable pluck passive reflector components **68f** in their deployed state.

[0106] In the illustrative passive reflector component **14f** seen in FIGS. 29 and 30, the structural framework **606** includes a thin-walled plastic tube **606** that can be made rigidly inflated, such as using pressurized air or another pressurized gas (e.g., a carbon dioxide cartridge) **604**, or deflated and collapsed to a small size for transport and storage (FIG. 29).

[0107] The reflector elements **68f** are vertically positioned along the axis of the inflatable structural pole **606**. In some embodiments, the reflector elements **68f** can be made of flexible metal tape such as copper tape, affixed to the outer surface of the structural plastic tube **606**, to form cylindrical metal tubes when the structural pole **606** is inflated.

[0108] As seen in FIG. 29, the base **602** of the illustrative passive reflector component **14f** contains a compressed gas

reservoir **604**, which can be used to deploy a flexible membrane **606** with reflector elements **68f** positioned through its length. Upon deployment, the gas inflates the membrane **606**, forming a long rigid tube rising above its container **602**, as shown in FIG. 30. The reflector elements **68f** can be placed coaxially and around the structural pole and are stacked on the pole, such as in a manner resembling the passive reflector component **14a**. As seen in FIG. 30, one or more passive reflector component **14f** can be placed on the ground, such as within a constrained environment ENV.

Flat Panel Passive Reflector Components

[0109] FIG. 31 provides a schematic view of a flat panel passive reflector component **14g**, using a metallized reflector element **682** and a plastic tarpaulin structural element **684**, which can be hung or mounted to a wall within a constrained environment ENV. The structural framework **684** for the passive reflector component **14g** can be provided as a flat sheet **684**, such as a blanket or a tarpaulin made of a suitable dielectric material. The sheet **684** can be folded into a compact size and shape for ease of transport, and unfolded at the desired installation site ENV.

[0110] The illustrative reflective element **682** typically comprises a flat panel of metalized, biaxially-oriented polyethylene terephthalate, commonly known by the brand name Mylar™, which is attached to the structural sheet **684**. This approach and construction differs from flat panel passive reflector components **14**, e.g., **14d**, which in some embodiment use rigid sheets of aluminum **68d**.

[0111] The flat panel reflector component **14g** can be used for a range of frequencies and also provides the highest gain. The upper frequency limitation is a function of reflector flatness. In an illustrative embodiment, surface gaps or roughness must be less than $\lambda/10$. At 400 MHz, $\lambda=29.5$ " so flatness must be better than 3". In such an embodiment, at 2300 MHz, $\lambda=5.13$ " so flatness must be better than 0.5".

[0112] In some embodiments, the illustrative flat panel reflector component **14g** shown in FIG. 31 uses standard off the shelf survival metalized mylar thermal blankets (~0.5 mil thick). The implementation is designed to be used at communication frequencies of 400 MHz and S-Band (1.8 to 2.3 GHz). The area of the flat panel reflector can be designed according to the equation

$$Gr=22.2+40 \log(f)+20 \log(A)+20 \log(\cos)$$

[0113] where

[0114] Gr=desired two-way gain of reflector in dBi

[0115] F=frequency in GHz

[0116] A=area of passive reflector in square feet; and

[0117] $\Theta=1/2$ of the included angle between the incident and reflected paths

Dual Pole Vertical Reflector Components

[0118] FIG. 32 provides a schematic view **700** of dual pole passive reflector components **14h**, wherein each passive reflector component **14h** includes a structural pole with coaxially-positioned dual reflectors **68**. In this embodiment **14h**, the structural framework **62** for the passive reflectors **68** can readily be configured as foldable pole arrangement (FIG. 4), or as an inflatable puck **602** (FIG. 29). The illustrative structural arrangement **62** in FIG. 32 includes two poles **62** spaced at a measured or predetermined distance from each other. As similarly shown in FIG. 4, each of foldable poles can be configured using hollow poles **82** made of a suitable

dielectric material such as fiberglass. In some embodiments, an elastic cord **86** is run through the hollow fiberglass poles **86**, to serve as a tensioning mechanism. The tubes **821** can be collapsed and folded for transport and storage, and installed at the location by interconnecting the pole segments **82**.

[0119] In puck component embodiments **14h**, each of the pair of inflatable pucks **602** can include a thin-walled plastic tube **606** that can be made rigidly inflated, such as using pressurized air or another pressurized gas (e.g., a carbon dioxide cartridge) **604**, or deflated and collapsed to a small size for transport and storage.

[0120] The reflector elements **68** are vertically positioned along the axis of the structural pole **62**. In some embodiments, the reflector elements **68** are preferably hollow cylindrical tubes constructed of a metal such as aluminum and placed coaxially and around the structural pole **62**. Alternatively, the reflector elements **68** can be constructed using metal or metalized tape affixed around a hollow tube of any of a variety of materials. In some embodiments, the reflector elements **68** can be arranged as dual elements, e.g., two elements abutting each other, stacked on each of the two poles **68**, as shown in FIG. 32, with an appropriate spacing between each pair of dual elements **68**.

[0121] The length of the reflector elements **68** can be selected to provide resonance at the desired frequency of operation. In some embodiments, the length can preferably approximate half the wavelength (0.5λ) of the signal, as adjusted by an appropriate adjustment factor corresponding to the material of the reflector **68** and its size and thickness. The distance from the center of one reflector element **68** to the center of the next reflector element **68** can correspond to approximately 0.75λ , which can be adjusted as discussed above.

[0122] A specific illustrative embodiment of the dual-pole reflector component includes eight aluminum reflector elements **68**, eight dielectric fiberglass support poles **62**, and two aluminum support bases **70** (FIG. 3).

[0123] To support an illustrative UHF radio frequency of 400 MHz, the reflector element length can be optimized to be 13.1" for resonance, using a 0.5λ length, adjusted by an adjustment factor of 0.888. The center-to-center distance between two adjacent reflectors can be optimized to 20.1", or 0.75λ using the same adjustment factor. The two support poles are placed 42" apart. This arrangement provides a total maximum gain of 11.0 dBi. The antenna dimensions including the support structure are 42"×0.625"×80".

[0124] FIG. 33 shows 3D radiation patterns **720** for one reflector element in a dual pole passive reflector. FIG. 34 is a chart **740** that shows vertical and horizontal radiation patterns for one reflector element of an illustrative dual pole reflector assembly.

[0125] FIG. 35 is a schematic diagram **780** for illustrative placement of a dual pole reflector assembly **14h** within a constrained environment ENV. Fig. 35 also shows corresponding radiation patterns and preferred communication directions for a dual pole reflector assembly **14h**. As seen in FIG. 35, one or more dual pole reflector assembly **14h** can be placed on the ground in a tunnel network ENV.

Helical Wire Reflector Components

[0126] FIG. 36A and 36B are schematic diagrams **800**, **820** for illustrative helical wire reflector components **14i**. In this embodiment **14i**, the structural framework **62** for the

passive helical wire reflectors **802** can readily be configured as foldable pole arrangement (FIG. 4), or as an inflatable puck **602** (FIG. 29).

[0127] In this embodiment **14i**, the structural framework **62** for the passive helical wire reflectors **802** can readily be configured as foldable pole arrangement (FIG. 4), or as an inflatable puck **602** (FIG. 29).

[0128] The foldable pole arrangement uses hollow poles **82** made of a suitable dielectric material such as fiberglass. An elastic cord is run through the hollow fiberglass poles, serving as a tensioning mechanism. The tubes **82** can be collapsed and folded for transport and storage, and installed at the location by interconnecting the pole segments **82**.

[0129] The inflatable puck structural arrangement uses a thin-walled plastic tube **606** (FIG. 29) that can be made rigidly inflated, such as using pressurized air or another pressurized gas (e.g., a carbon dioxide cartridge) **604**, or deflated and collapsed to a small size for transport and storage.

[0130] The reflector elements **802** are made of conductive wire that can be helically wound around the structural pole **62** and/or vertically positioned along the axis of the inflatable structural pole **606** as shown in FIG. 36B.

[0131] As an example, a specific implementation **14i** includes four separate helical turn wires **802**, which can be mounted around an inflatable tube **606**, that serves as the structural element **62**.

[0132] FIG. 37 shows 3D radiation patterns **840** for one helical wire reflector element associated with a helical wire reflector component. FIG. 38 is a chart **860** that shows vertical and horizontal radiation patterns for one helical wire reflector element associated with a helical wire reflector component **14a**. To support an illustrative UHF radio frequency of 400 MHz, the reflector element length can be optimized to be 13.5" for resonance, using a 0.5λ length, adjusted by an adjustment factor of 0.915. The end-to-end distance between two adjacent reflectors can be optimized to 12.6". This arrangement provides a total maximum gain of 8.6 dBi. In some embodiments, the helical wire reflector components **14i** can be placed on the ground, such as within a constrained environment ENV.

Rapid Deployment Methods

[0133] The passive reflectors of the various embodiments above can be deployed by a person or in an automated manner.

[0134] In some embodiments, a person **USR** can travel through the tunnels, installing the passive reflectors **14** at appropriate locations within a constrained environment ENV, such as at corners, at intersections, at predetermined positions, or at locations where a signal detector indicates diminished reception.

[0135] For instance, a signal source can be established at the entrance to a mine, and is set up to emit radio waves at a determined frequency. A vehicle that can traverse the mine tunnels is outfitted with two receivers, one at the front and one at the rear of the vehicle. A number passive reflectors **14** are carried on the vehicle or by a human for deployment. As the vehicle travels through the tunnels, there will be locations where the front receiver passes outside the range of the source signal while the rear receiver still has reception. The passive reflectors **14** can be deployed at this location, as it would be well suited for the installation of a repeater system.

[0136] In some embodiments, the deployment of illustrative embodiments of the passive reflector components **14** can be carried out by an occupant of the vehicle, or dropped from a vehicle driving through the space. Automatic deployment can take place when a turn is made, or a sensor detects that the received signal has diminished to need a reflector **14**. The sensor can be mounted on the front of the vehicle to give time for reflectors to be deployed from the rear before going around the corner of a tunnel. Embodiment **8** (the inflatable puck) can be enabled to inflate and deploy automatically when dropped on the ground.

[0137] Passive reflector components **14** can be designed in form factors that are compact to transport and at the same time are amenable to automatic, quick deployment or unfurling. For example, the above-described approach can also be used with the foldable pole and sheet passive reflector designs. In particular, the sheet designs of reflector component embodiments **14d**, **14e** and **14g** can be quickly deployed by attaching the top edge to a wall and allowing gravity to unroll and thus deploy them.

[0138] In other system embodiments **10**, embodiments **15** that are based on a sheet or mesh system can be implemented on a mesh fabric panel with a flexible frame that can be twisted into a compact shape and that, when released, unfolds into its full size. In another variation, a self-righting pyramid structure can be used as the structural framework. When dropped to the ground, the system arranges itself into a configuration that is conducive to passive reflection of the desired frequencies.

Alternative Embodiments

[0139] While the invention is described above in the context of radio communications in underground and constrained environments such as mine tunnels, the invention can also be extended to a variety of other applications. Some examples are provided in this section.

Deployment in a Diversity of Devices and Frequencies

[0140] While the deployment of embodiments of the invention are described as multiple instances of the same embodiment, it will readily be seen that different embodiments of the passive reflector components can be utilized and can work together to provide a specific communication requirement.

[0141] As an example, a tunnel may have sections that are tall and narrow, where implementations of passive reflector components **14a**, **14b**, **14c** and/or **14h** can be deployed, as well as other sections that are low with walls that accommodate passive reflector components **14d**, **14e**, **14f** and/or **14i**.

[0142] Embodiments of the passive reflector components **14** can also work in conjunction with other equipment that operates in the same frequency. As an example, embodiments of the passive reflector components **14** may be used along with active repeaters, providing a flexible solution to users who may have a diverse inventory of available equipment.

[0143] The passive reflector components **14** provide gain and signal reflectivity capability in a range of frequencies around the specific frequency they are designed for. This permits flexibility in the choice of signal frequencies.

Exploration of Caves and Underground Complexes

[0144] The exploration and survey of underground features such as caves, tunnels, cenotes, lava tubes, and abandoned mines, is carried out in constrained conditions, with little or no knowledge of the terrain and the layout of underground pathways. In such applications, radio signals from an external source will have limited reach, and repeaters will be needed to ensure communications for the exploring party. It will be impractical for an exploring party to carry arbitrary numbers of active repeater equipment with associated wiring or battery systems and deploy them to maintain radio communications with the surface. The various embodiments of the portable deployable underground communication system described above can be more easily carried in large numbers, deployed quickly as required at locations, take up little space in constrained environments, and provide passive performance.

Search and Rescue

[0145] Some embodiments of the invention can be utilized in search and rescue missions. For example, an earthquake in an urban area may result in damage to existing communications and electrical infrastructure. As rescue crews navigate the rubble, they would benefit from portable deployable radio communication systems that could provide an effective communications link to a base location. Rescuers would be able to carry lightweight systems that would auto-deploy when positioned, and by deploying them at regular intervals, adequate signal strength can be obtained. Similar applications can also be considered in search and rescue operations in outdoor environments such as wooded areas, mountainous terrain, or even open country where communications and power infrastructure are not readily available and the needs of the situation are rapidly evolving.

Communications in Mountainous Terrain

[0146] Practical applications of the disclosed passive reflector communications systems can also be found in mountainous or otherwise challenging terrain where line of sight communications may be occluded by natural or man-made features. For example, it is common for mobile cellular telephone signals to have limited reach in mountainous regions, even in large urban areas where communications infrastructure is typically densely available. For example, a narrow valley branching out of a canyon can serve a small population of residents. A passive reflector system would be a practical and effective solution. Further, the invention's portability and deployability characteristics allow installation in potentially constrained locations such as high ridges or narrow roadside walls in canyons. As an example, passive reflector component **14d** can be deployed on a water tower to provide coverage in challenging terrain.

Covert and Military Operations

[0147] In covert or military operations, there may be an existing radio communications infrastructure; however, it may be unavailable to the military team who will need to operate using different equipment and radio frequencies. The team can carry portable radios operating in a secure band, and use the portable deployable passive reflectors of the invention to extend signal coverage to their evolving areas of operation. This solution has the additional benefit that the

discovery or capture of the passive reflector systems by an adversary will not have the effect of compromising the secure communications frequency for future missions, as no active equipment is left behind.

System Testing and Alternate Embodiments

[0148] FIG. 39 is a schematic diagram 880 of a deployed balloon reflector component 14j in a tunnel network, which includes vertical strip reflectors 68j, e.g., for L-Band or S-band operation, that are attached to a balloon 882, in which the balloon 882 can be deployed 890 within a constrained environment ENV, such as from a deployment module 886, such as a puck structure 886 containing one or more gas cylinders 906, e.g., helium cartridges 904 and a corresponding balloon inflation mechanism 902. FIG. 40 is a schematic view 900 of a deployment module 886 for a balloon reflector component 14j. In some illustrative embodiments of the balloon reflector components 14j, the vertical strip reflectors 68j are optimized for S-Band operation, in which the vertical strip reflectors 68j are 2.25"L×¼"W, with 2.5" space between elements. In some illustrative embodiments of the balloon reflector components 14j, the vertical strip reflectors 68j are optimized for L-Band operation, in which the vertical strip reflectors 68j are 3.95"L×¼"W, with 4.5" space between elements.

[0149] Different embodiments of passive reflector components 14 were installed and tested within an underground environment ENV, to investigate different methods for underground communication in the L-band and S-Band frequency range. The testing was performed using an array of self-supporting planar tarp components 14 and helium balloon multi-band vertical strip reflectors 14j.

[0150] The wireless radios 18 used during the testing were Model MPU5 Wave Relay Networked and Digitally Encrypted communication radios 18, e.g., 18a, 18b (FIG. 1), available through Persistent Systems LLC, of New York, NY. During the testing, one of the radios 18a was located in a fixed position, while the other radio 18b was movable within the constrained environment ENV. Two computers were also used, one to program the radio's RF modules, and the other to monitor and record the signal to noise ratio (SNR) of the MPU5s 18.

[0151] During some of the testing procedures, the radios 18 were evaluated at both 1370 and 2400 MHz, in which the first radio 18a was located approximately 1000 feet from a 90 degree turn, at a fixed position, and win which starting position of the second radio 18b was line-of-sight or 1000 feet away from the first radio 18a at a 90 degree turn position, then moved away to a maximum distance of 2000 feet from the 90 degree turn (or 3000 feet total distance away from the first radio's position). Signal to Noise Ratio (SNR) data for the signals 20 was recorded as the second radio 18b moved further away from the 90 degree turn location. This testing was repeated, both without and with different embodiments of passive reflector components 14 located at the 90 degree location.

[0152] The results of the testing indicated an increased distance of at least three times for voice communication using the passive reflector components 14. For example, without the use of passive reflector components 14 during testing, loss of communications occurred at 1300 to 1400 feet.

[0153] For similar test conditions, with the use of passive reflectors 14, no loss of communications occurred at 3000

feet, which was the maximum available tunnel distance. There was still a 12 to 25 dB communications margin at 3000 feet (dependent on reflector size and frequency).

[0154] Design and evaluation can also be carried out on different sizes and types of passive reflector components 14, to provide expected underground communications coverage vs. aperture, in an existing tunnel or other constrained environment ENV. For instance, the performance of different passive reflector components 14 can be evaluated for different shaped tunnels, such as to provide optimal passive reflectors and polarization guide lines.

[0155] The following is a summary of performance and technical details of the tested L & S Band High Gain Tarp Reflectors:

[0156] L & S Band Maximum Digital Voice Communication Coverage without Reflector:

[0157] 1300 to 1400 feet (1000 feet to 90 deg turn then an additional 300 to 400 feet).

[0158] L & S Band Minimum Digital Voice Communication Coverage with Reflector:

[0159] 3000 feet (1000 feet to 90 deg turn [at Reflector] then an additional 2000 feet)

[0160] CW Signal to Noise Ratio at 3000 feet: 35 to 37 dB (L-Band) and 40 to 42 dB (S-Band)

[0161] MPU5—Digital Voice Communication Margin at 3000 feet: 25 to 27 dB (L-Band) and 30 to 32 dB (S-Band).

[0162] L & S Band Tarp Reflector Details (usable for either Horizontal or Vertical polarization):

[0163] Size: 8×8 feet w/support, 6×8 feet (reflector), deployed in horizontal polarization

[0164] Number of Elements: 121 (L-Band), 380 (S-Band)

[0165] Directivity: Analysis predicts 26 dBi (L-Band), 31 dBi (S-Band)

[0166] Reflector Materials: Polyethylene w/reinforced fiberglass and 0.001" thick Cu elements.

[0167] The following is a summary of performance and technical details of the tested L & S Band—Dual Band Vertical Strip Reflectors:

[0168] L & S Band Maximum Digital Voice Communication Coverage without Reflector:

[0169] 1300 to 1400 feet (1000 feet to 90 deg turn then an additional 300 to 400 feet).

[0170] L & S Band Minimum Digital Voice Communication Coverage with Reflector:

[0171] 3000 feet (1000 feet to 90 deg turn [at Reflector] then an additional 2000 feet)

[0172] CW Signal to Noise Ratio at 3000 feet: 22 to 24 dB (L-Band) and 24 to 26 dB (S-Band)

[0173] MPU5—Digital Voice Communication Margin at 3000 feet: 12 to 14 dB (L-Band) and 14 to 16 dB (S-Band)

[0174] L & S Band Vertical Strip Reflector Details:

[0175] Size: 0.25 inch wide×12 feet tall (reflector)

[0176] Number of Elements: 18 (L-Band), 31 (S-Band)

[0177] Directivity: Analysis predicts 15 dBi (L-Band), 17 dBi (S-Band)

[0178] Reflector Materials: Nylon ribbon with 0.001" thick Cu elements

[0179] Weight: 15 grams each (L/S-Band vertical arrays)

[0180] Unless contrary to physical possibility, it is envisioned that (i) the methods/steps described above may be

performed in any sequence and/or in any combination, and that (ii) the components of respective embodiments may be combined in any manner.

[0181] Note that any and all of the embodiments described above can be combined with each other, except to the extent that it may be stated otherwise above or to the extent that any such embodiments might be mutually exclusive in function and/or structure.

[0182] Although the present invention has been described with reference to specific exemplary embodiments, it will be recognized that the invention is not limited to the embodiments described, but can be practiced with modification and alteration within the spirit and scope of the appended examples. Accordingly, the specification, drawings, and attached appendices are to be regarded in an illustrative sense rather than a restrictive sense.

What is claimed is:

1. A signal reflecting device comprising:
 - a flexible dielectric sheet component, and
 - a plurality of metal elements coupled to the flexible dielectric sheet component, wherein the plurality of metal elements are configured in a two-dimensional planar arrangement with each element having a length, a width, a horizontal distance between an adjacent metal element, and a vertical distance between an adjacent metal element.
2. The device of claim 1, wherein the length of one or more metal elements is one-half of a wavelength of a reflected signal reflected by the signal reflecting device.
3. The device of claim 1, wherein the width of at least one metal element is configured to be one inch, the horizontal distance between adjacent metal elements is configured to be 21.5 inches, and the vertical distance between adjacent metal elements is configured to be 13 inches.
4. The device of claim 1, wherein the width of at least one metal element is configured to be three inches, the horizontal distance between adjacent metal elements is configured to be 28.5 inches, and the vertical distance between adjacent metal elements is configured to be 12 inches.
5. A signal reflecting device comprising:
 - a container having a base and an internal portion;
 - a compressed gas reservoir arranged within the base of the container wherein the compressed gas reservoir is fluidly coupled to the internal portion of the container;
 - a flexible dielectric membrane having one end fixed to the internal portion of the container, wherein the flexible membrane has affixed thereto one or more flexible metal elements.
6. The signal reflecting device of claim 5, further comprising a gasket configured within the container, arranged between the base of the container and the internal portion of the container.

7. The signal reflecting device of claim 5, further comprising an inflation mechanism wherein the flexible dielectric membrane is configured to be in a deployed state via the inflation mechanism and compressed gas from the compressed gas reservoir.

8. The signal reflecting device of claim 5, wherein the one or more flexible metal elements are fixed to an outer surface of the flexible dielectric membrane.

9. A signal reflecting device comprising:

- a reflector array configured to reflect wireless communication signals, wherein the reflector array further comprises one or more reflector elements configured with a first directional alignment and one or more reflective elements configured with a second directional alignment that is orthogonal to the first directional alignment,
- a structural framework configured to support and orient the reflector array, the structural framework having a third directional alignment that is orthogonal to both of the first directional alignment and the second directional alignment.

10. The device of claim 9, wherein the reflector elements are configured to passively reflect wireless communication signals.

11. The device of claim 9, wherein the first directional alignment is in a horizontal direction.

12. The device of claim 11, wherein the second directional alignment is in a horizontal direction.

13. The device of claim 9, wherein the third directional alignment is in a vertical direction.

14. The device of claim 9, wherein the structural framework comprises a dielectric material.

15. The device of claim 9, further comprising one or more reflector elements configured with the third directional alignment.

16. The device of claim 15, wherein at least one of the reflector elements, configured with the third directional alignment, is further configured to intersect each of a reflector element configured with the first directional alignment and a reflector element configured with the second directional alignment.

17. The device of claim 9, wherein the reflector array further comprises a plurality of pairs of reflector elements, each pair consisting of a reflector element configured with the first directional alignment and a reflective element configured with the second directional alignment.

18. The device of claim 17, wherein at least one of the reflector elements, configured with the third directional alignment, is positioned between two of the reflector element pairs.

* * * * *