



US 20240027677A1

(19) **United States**

(12) **Patent Application Publication**
Karafin et al.

(10) **Pub. No.: US 2024/0027677 A1**

(43) **Pub. Date: Jan. 25, 2024**

(54) **SELECTIVE PROPAGATION OF ENERGY IN LIGHT FIELD AND HOLOGRAPHIC WAVEGUIDE ARRAYS**

H04N 13/388 (2006.01)

G02B 6/08 (2006.01)

G02B 27/01 (2006.01)

(71) Applicant: **LIGHT FIELD LAB, INC.**, San Jose, CA (US)

(52) **U.S. Cl.**
CPC *G02B 6/0096* (2013.01); *G02B 27/0994* (2013.01); *G02B 30/00* (2020.01); *G02B 30/33* (2020.01); *G02B 6/02042* (2013.01); *G02B 6/04* (2013.01); *G02B 27/1066* (2013.01); *G02B 6/023* (2013.01); *G02B 6/29325* (2013.01); *H04N 13/388* (2018.05); *G02B 6/08* (2013.01); *G02B 27/0172* (2013.01); *G02B 27/0955* (2013.01); *Y02E 10/52* (2013.01); *G02B 25/00* (2013.01)

(72) Inventors: **Jonathan Sean Karafin**, San Jose, CA (US); **Brendan Elwood Bevensee**, San Jose, CA (US)

(21) Appl. No.: **18/199,505**

(22) Filed: **May 19, 2023**

Related U.S. Application Data

(63) Continuation of application No. 16/882,422, filed on May 22, 2020, now Pat. No. 11,681,092, which is a continuation of application No. 16/064,178, filed on Jun. 20, 2018, now Pat. No. 10,663,657, filed as application No. PCT/US2017/042276 on Jul. 14, 2017.

(60) Provisional application No. 62/362,602, filed on Jul. 15, 2016, provisional application No. 62/366,076, filed on Jul. 24, 2016, provisional application No. 62/507,500, filed on May 17, 2017.

Publication Classification

(51) **Int. Cl.**
F21V 8/00 (2006.01)
G02B 27/09 (2006.01)
G02B 30/00 (2006.01)
G02B 30/33 (2006.01)
G02B 6/02 (2006.01)
G02B 6/04 (2006.01)
G02B 27/10 (2006.01)
G02B 6/293 (2006.01)

(57) **ABSTRACT**

Disclosed embodiments include an energy waveguide system having an array of waveguides and an energy inhibiting element configured to substantially fill a waveguide element aperture and selectively propagate energy along some energy propagation paths through the array of waveguides. In an embodiment, such an energy waveguide system may define energy propagation paths through the array of waveguides in accordance to a 4D plenoptic system. In an embodiment, energy propagating through the energy waveguide system may comprise energy propagation for stimulation of any sensory receptor response including visual, auditory, somatosensory systems, and the waveguides may be incorporated into a holographic display or an aggregated bidirectional seamless energy surface capable of both receiving and emitting two-dimensional, light field or holographic energy through waveguiding or other 4D plenoptic functions prescribing energy convergence within a viewing volume. The waveguides may include different structures configured for each or all sensory system or energy domain to direct energy through refraction, diffraction, reflection, or other approaches of affecting the propagation paths of energy.

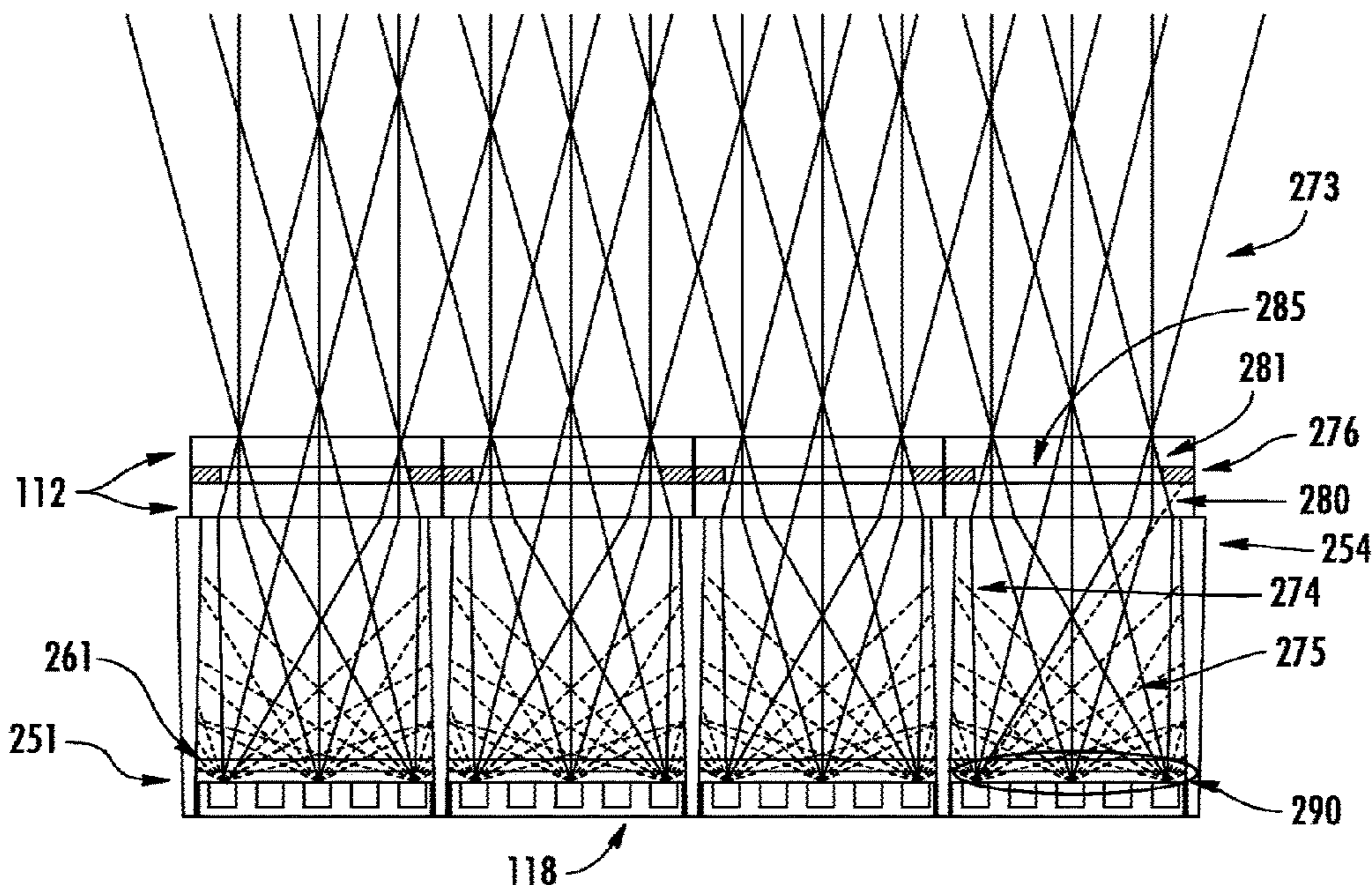

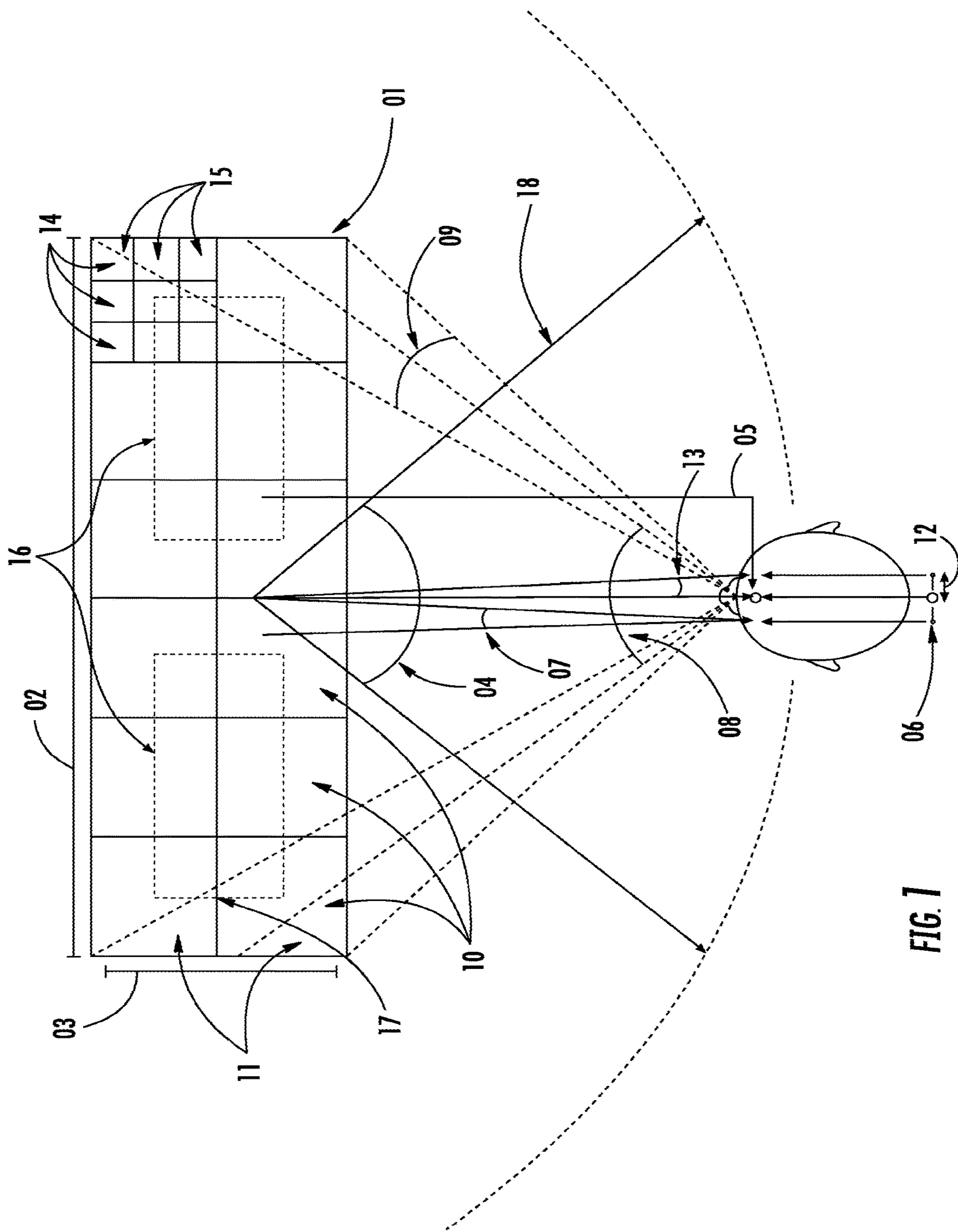

FIG. 1

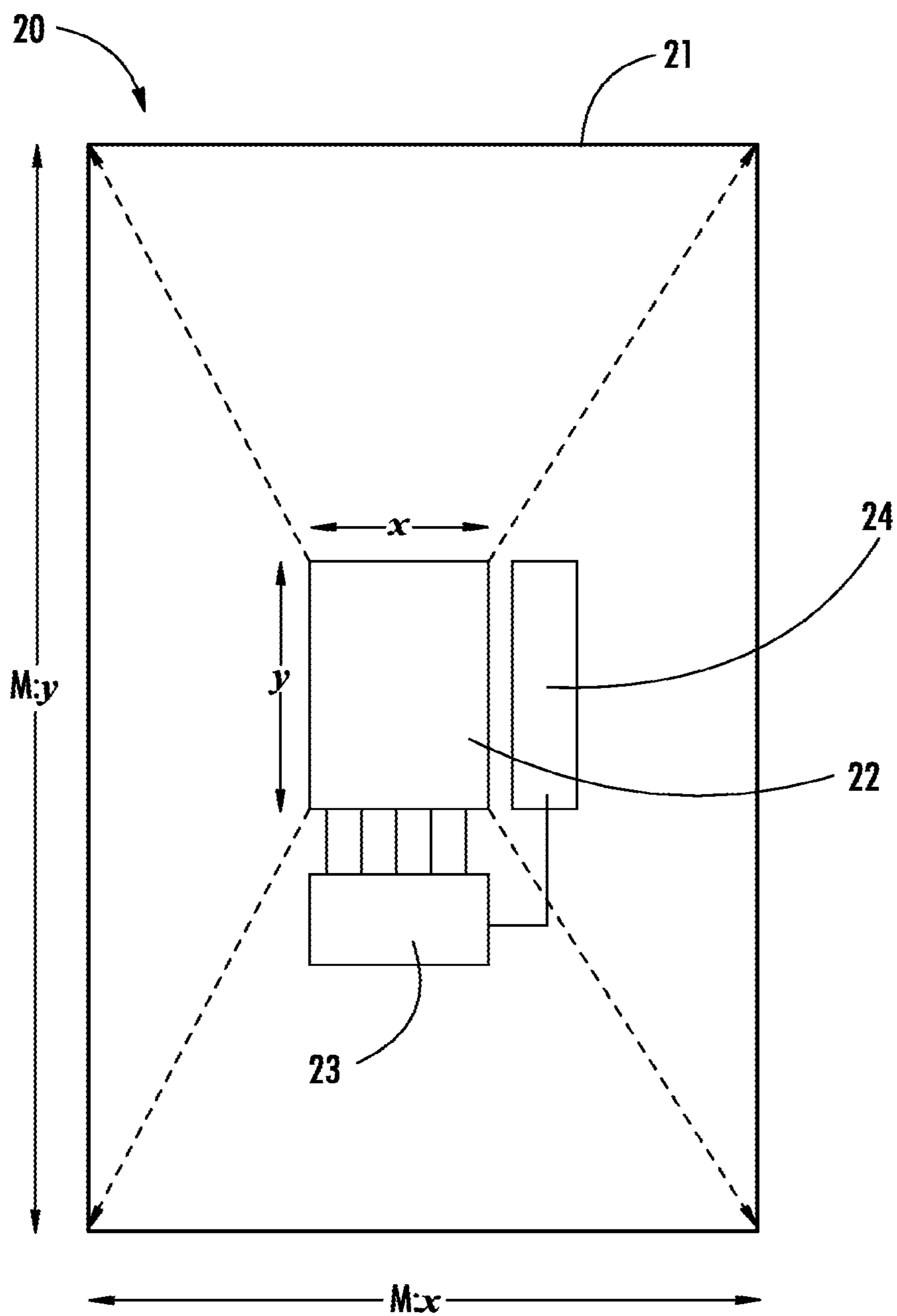

FIG. 2

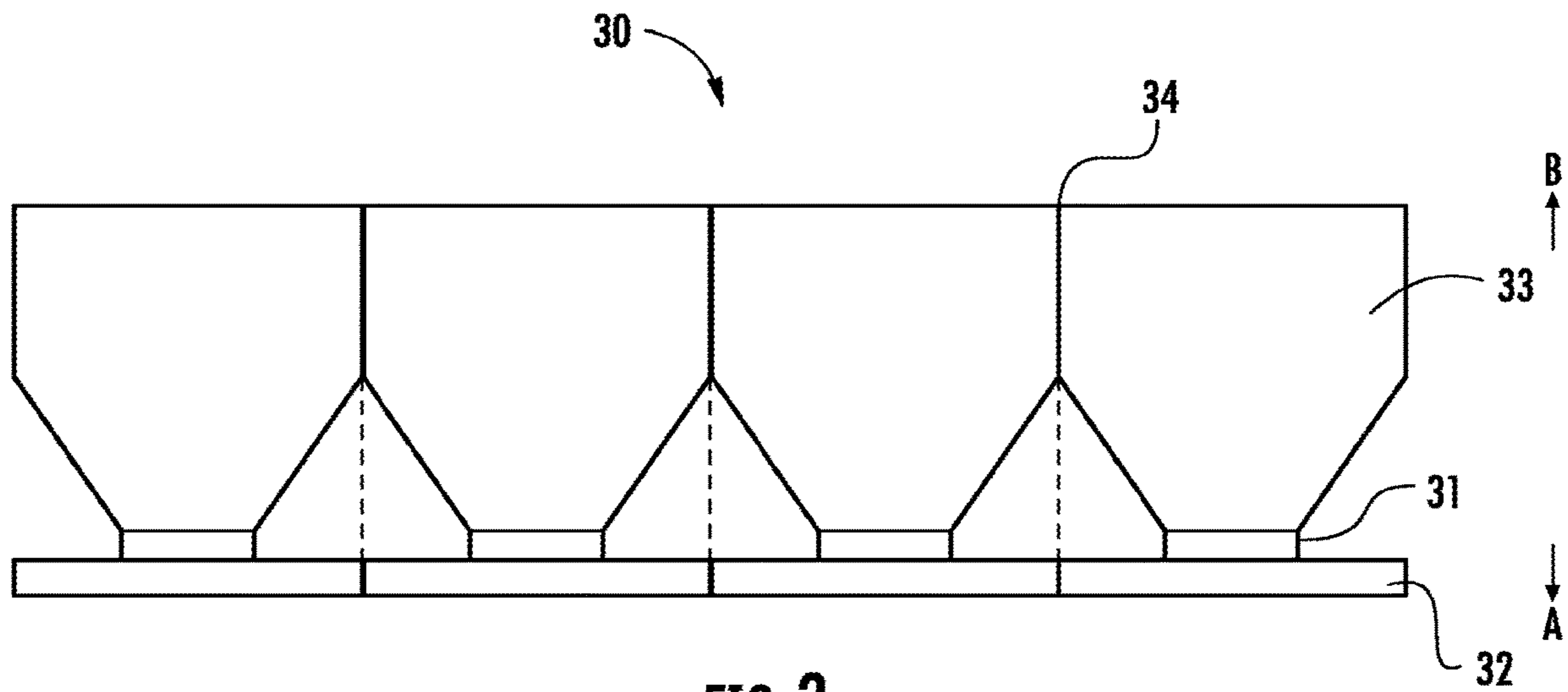

FIG. 3

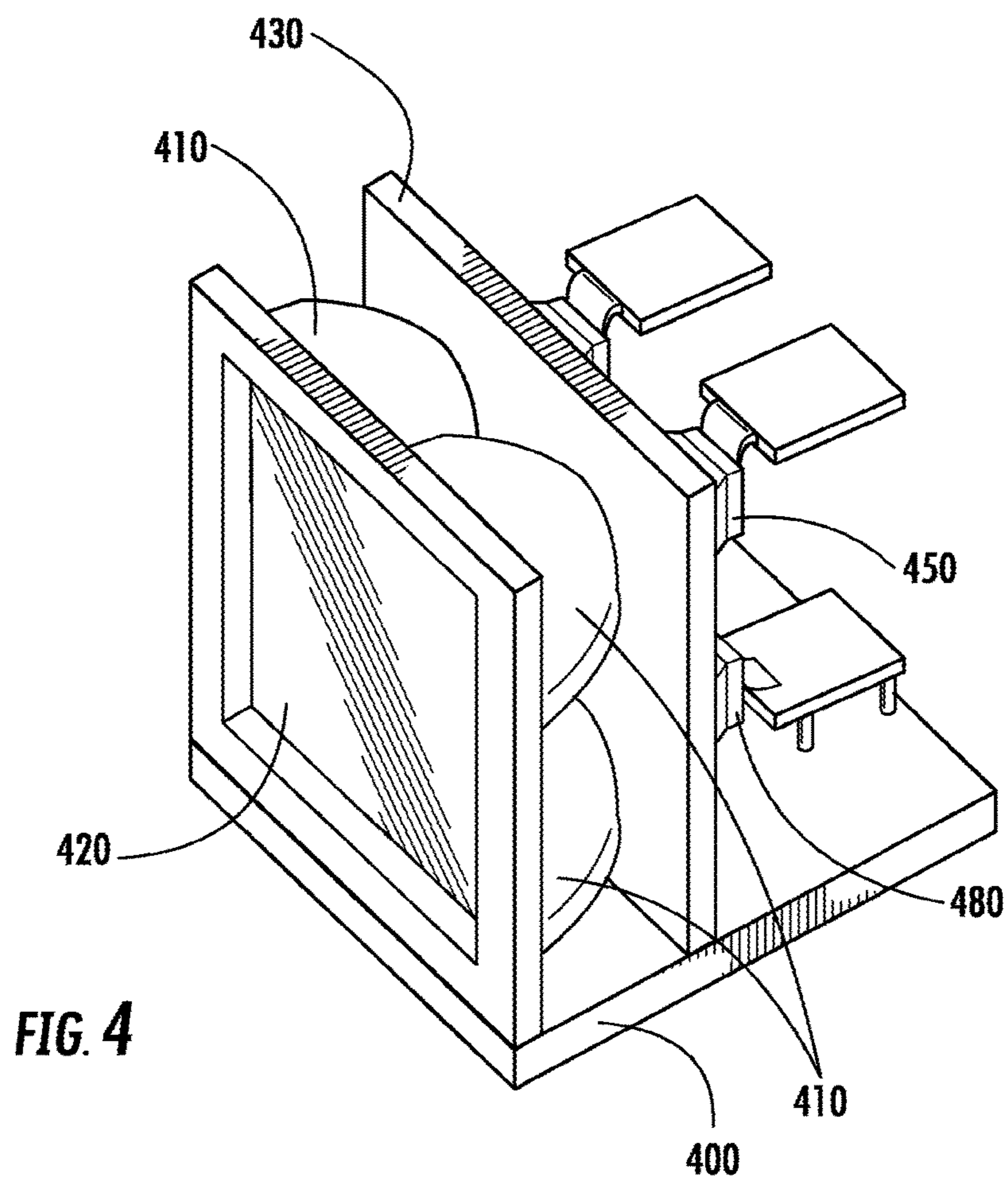

FIG. 4

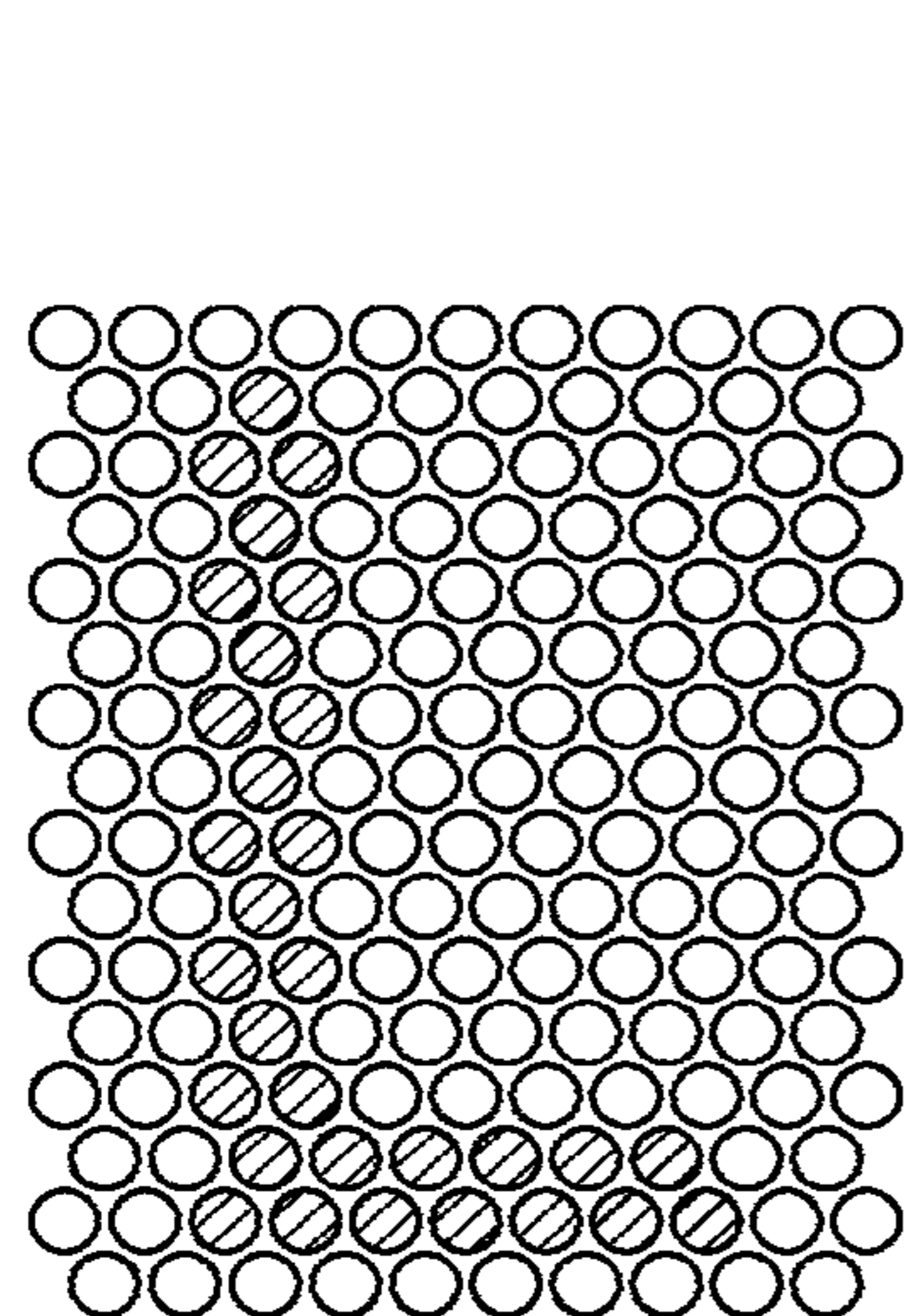

FIG. 5A

500

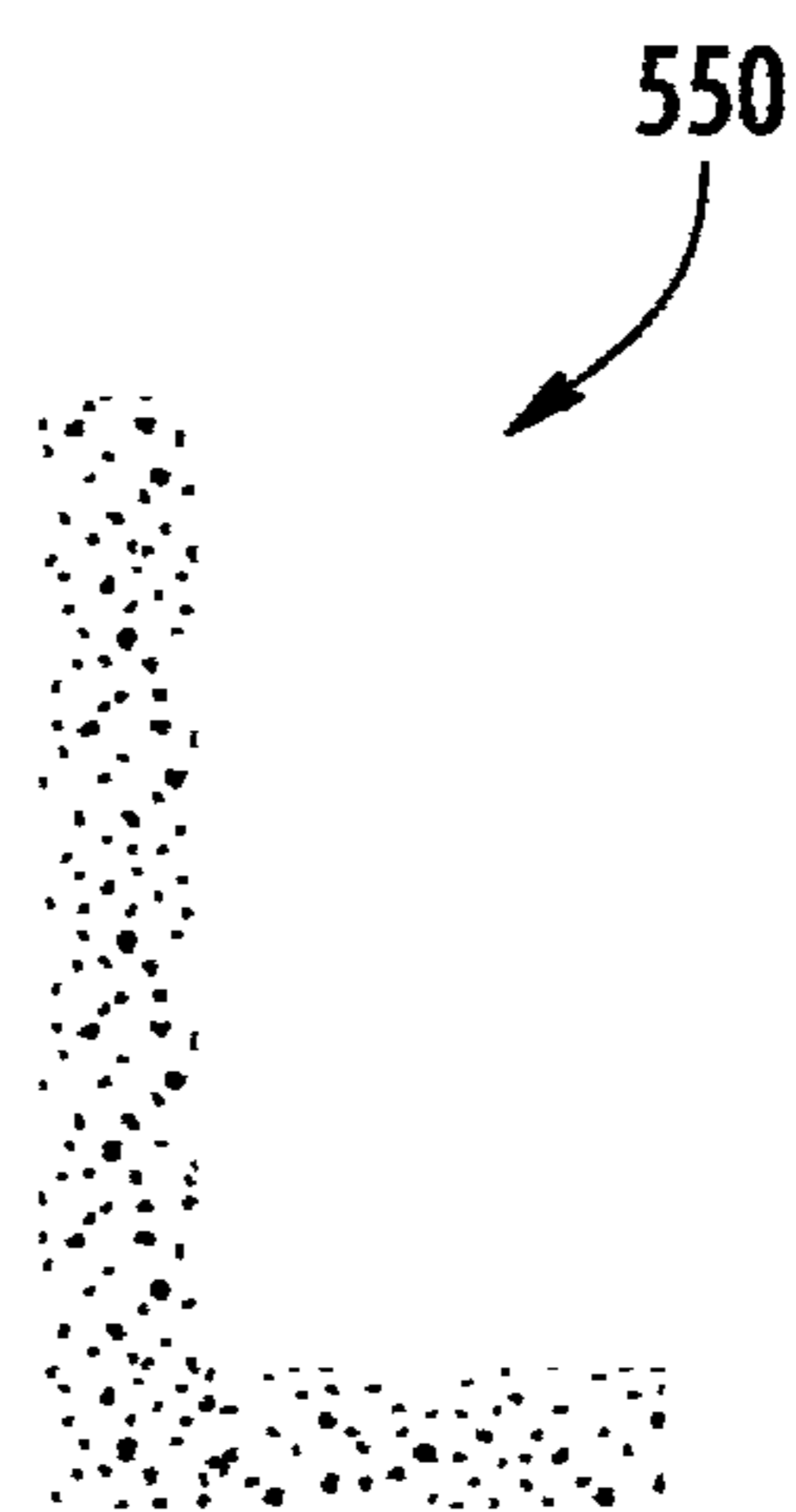

FIG. 5B

550

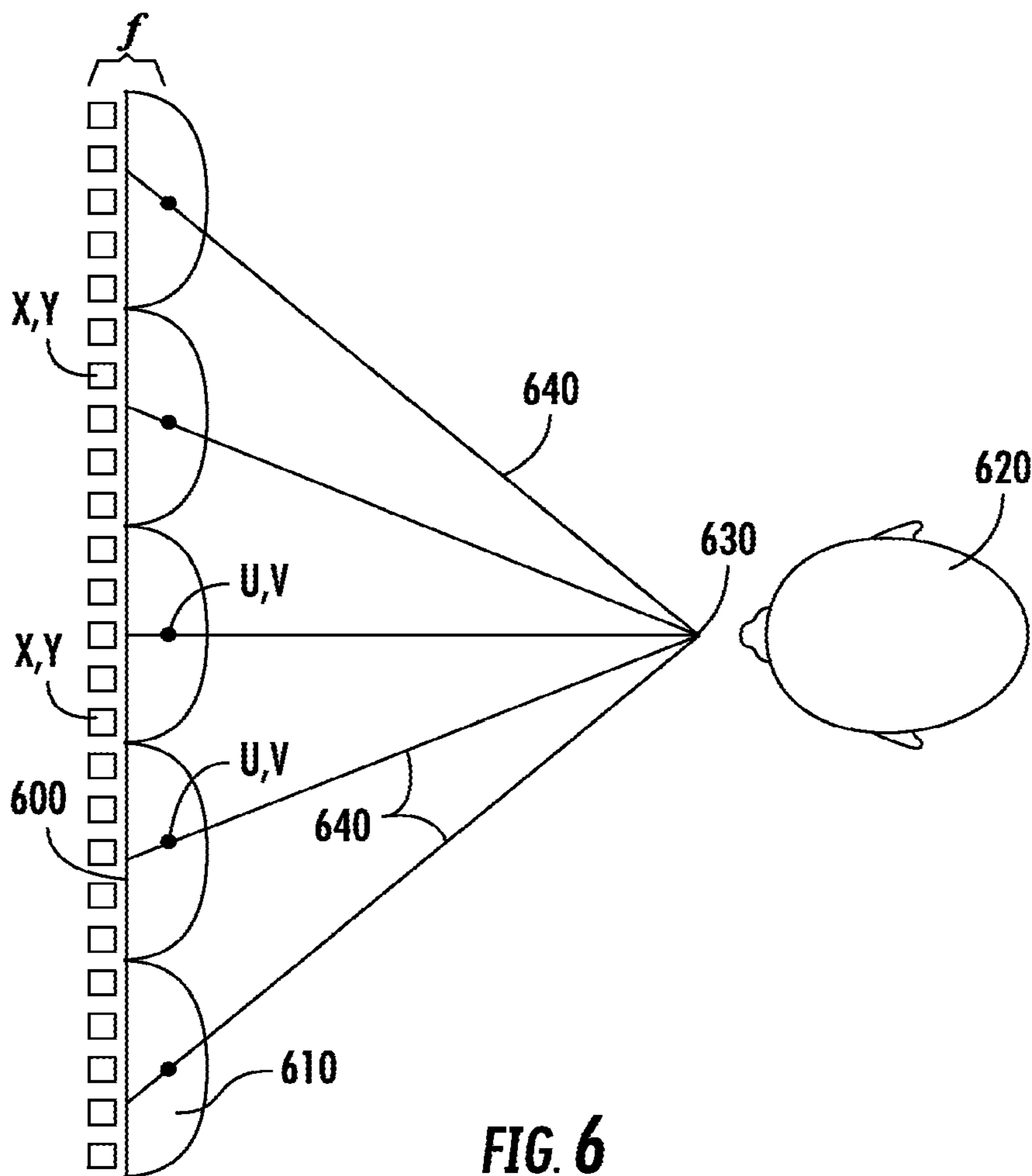

FIG. 6

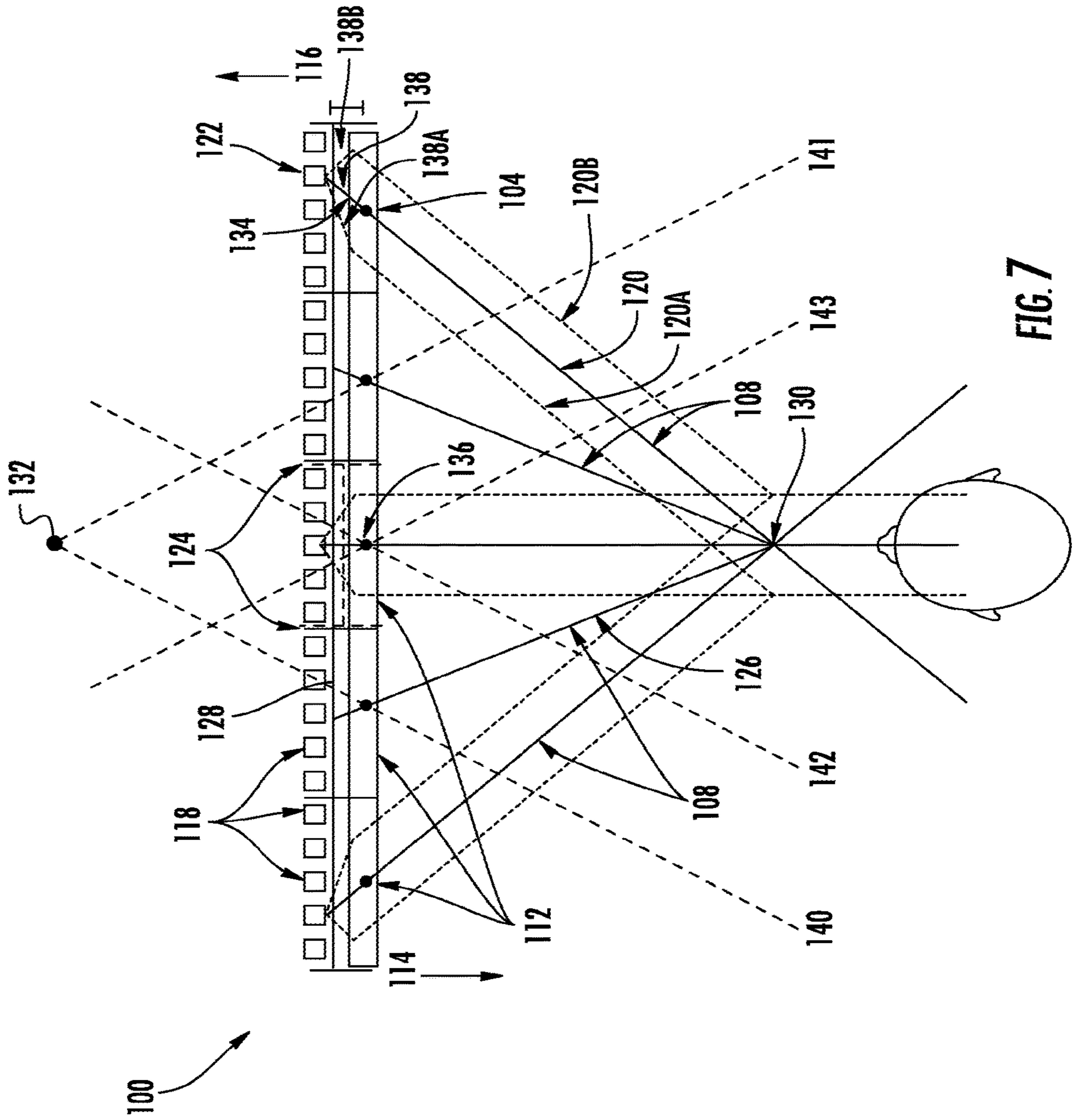

FIG. 7

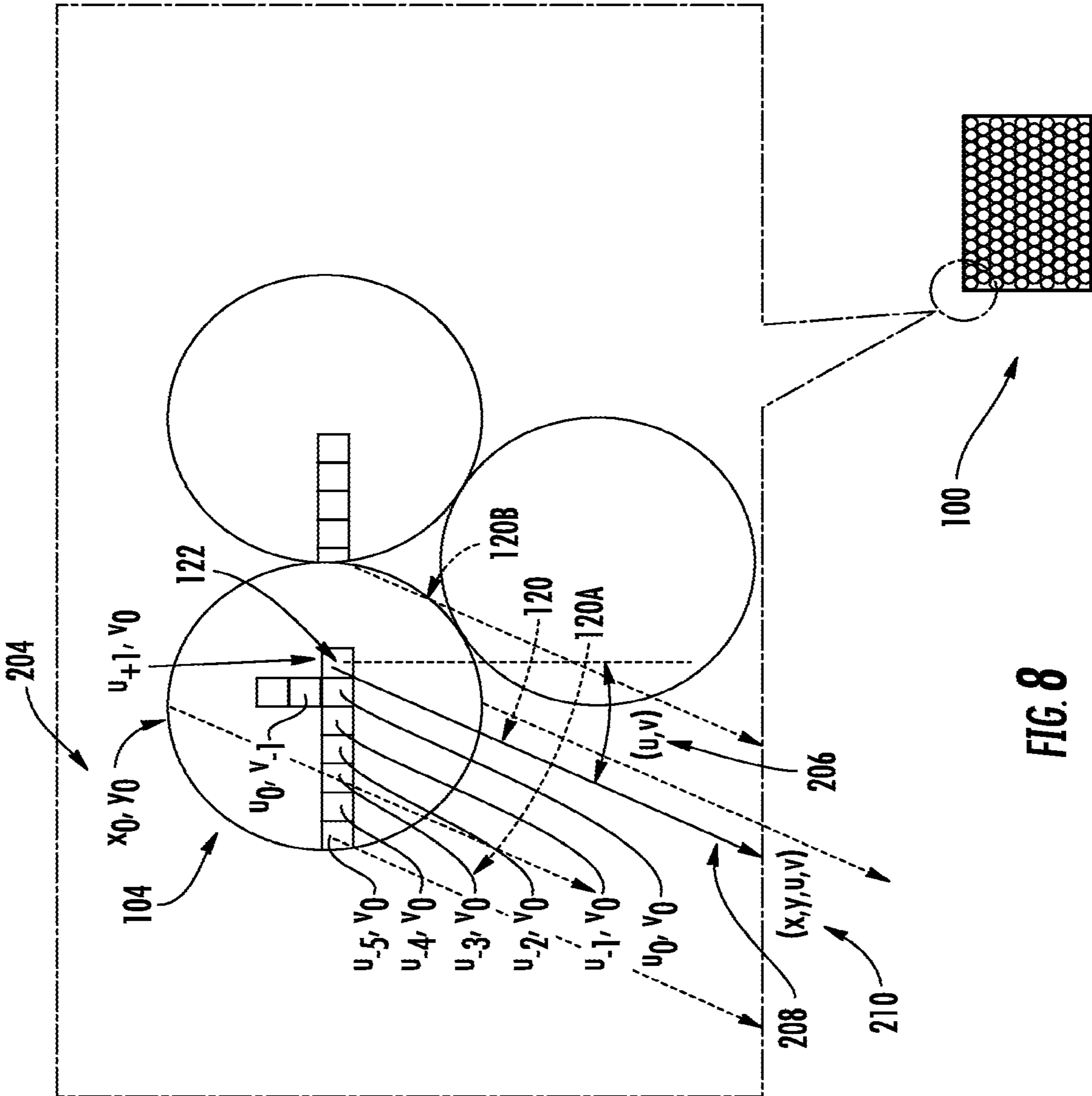
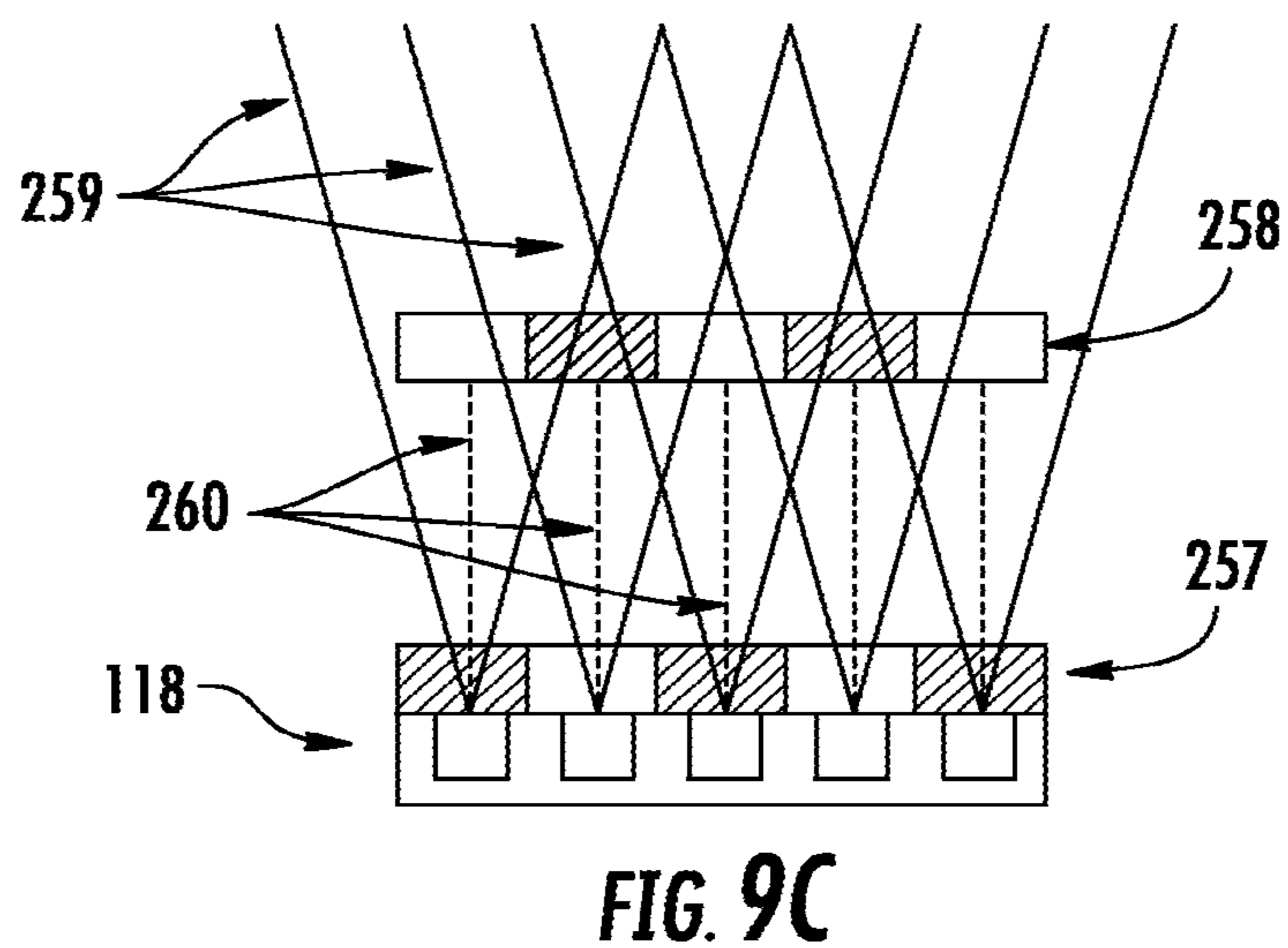
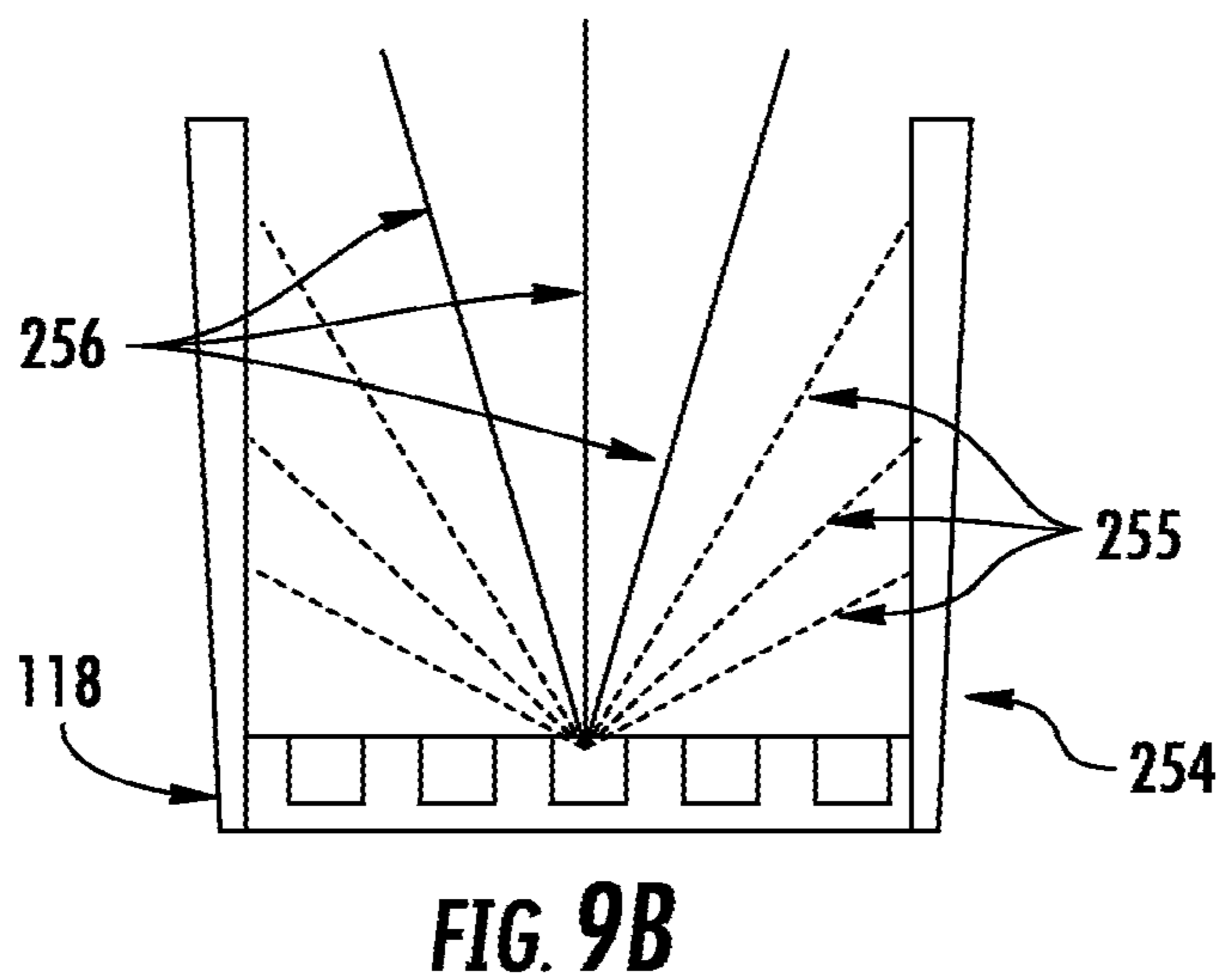
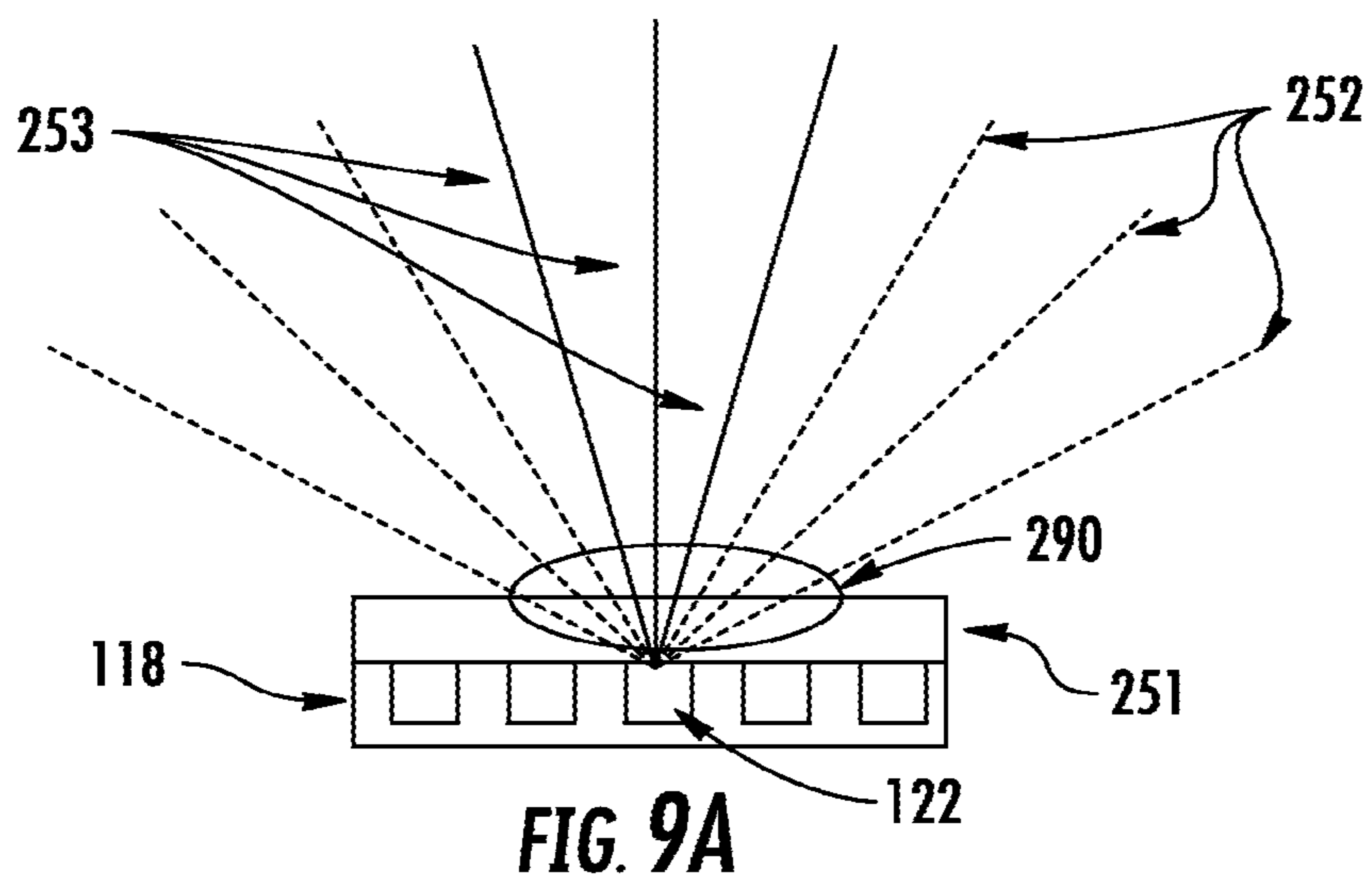

FIG. 8



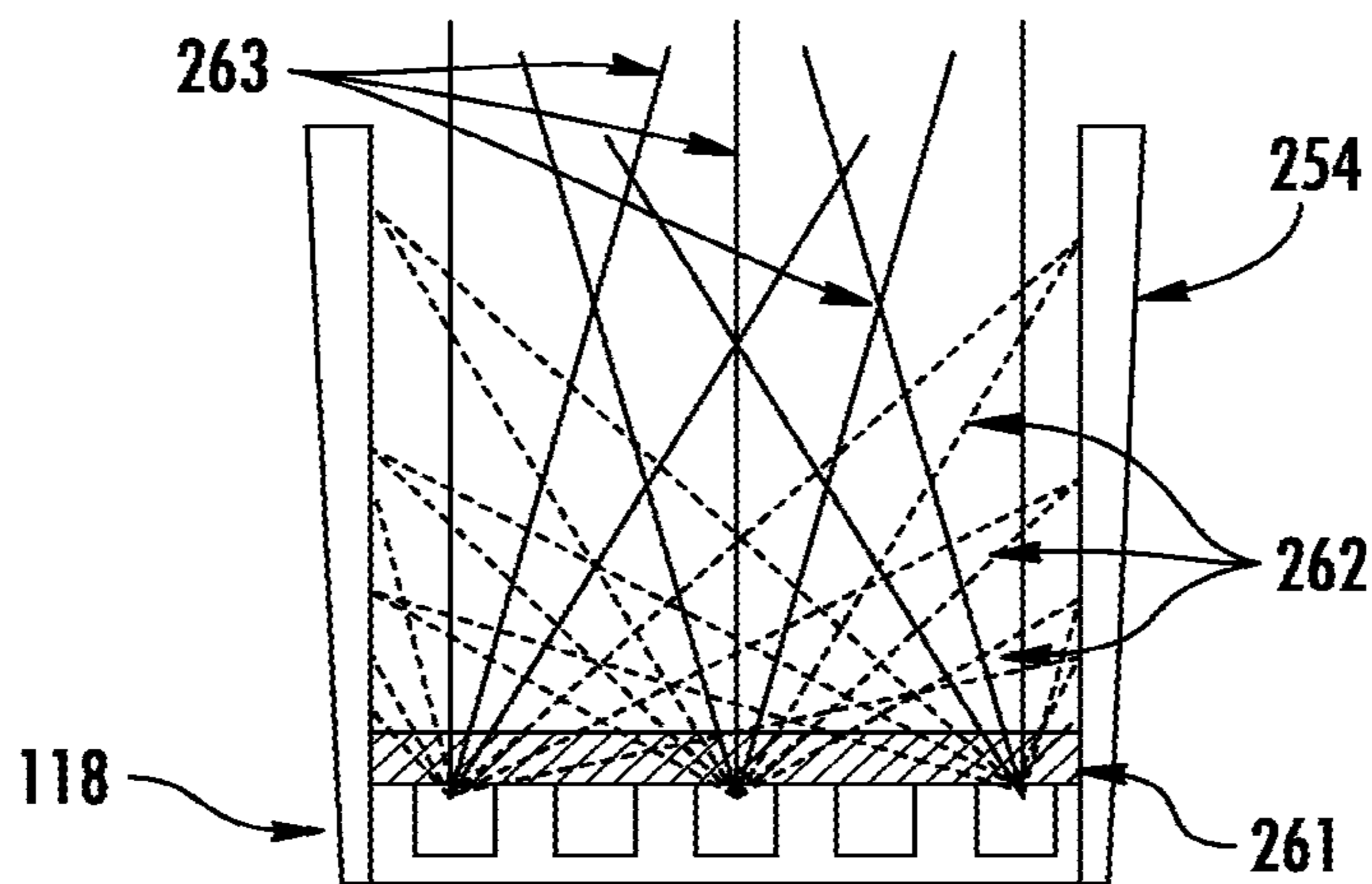

FIG. 9D

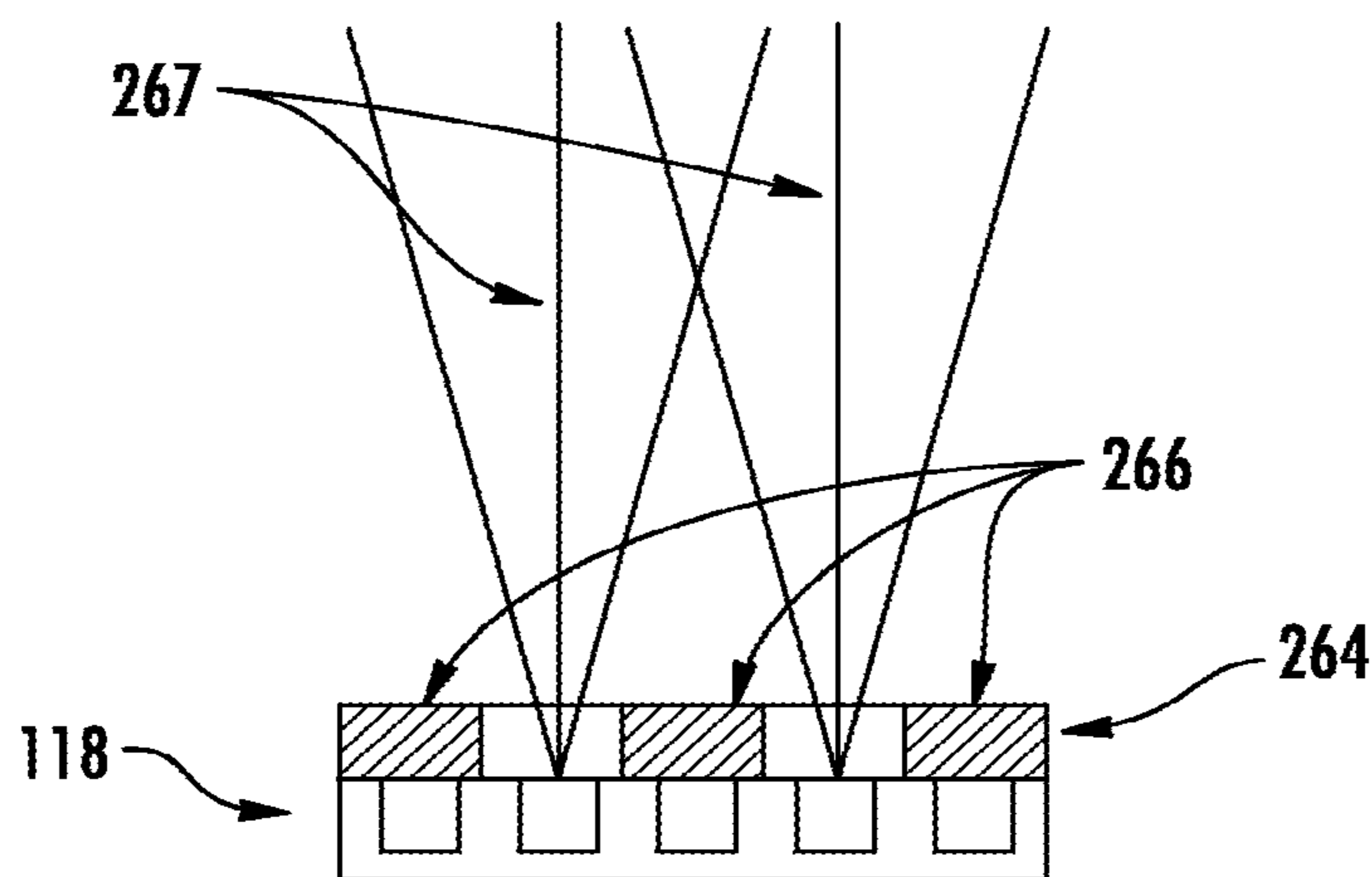

FIG. 9E

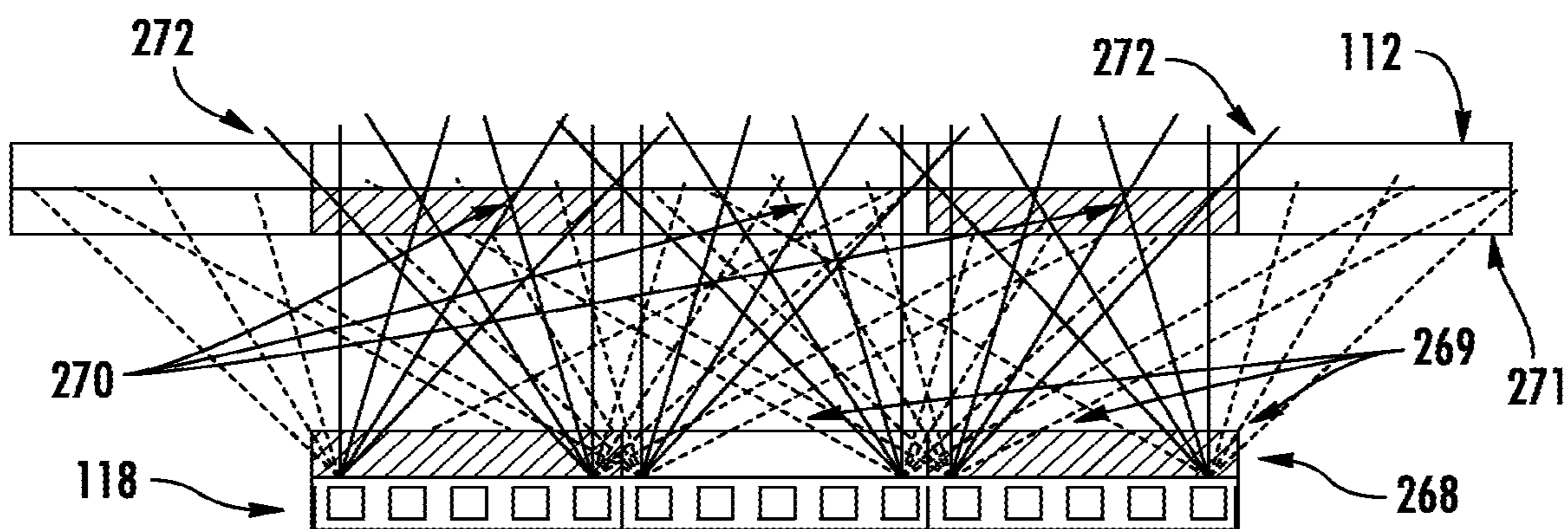
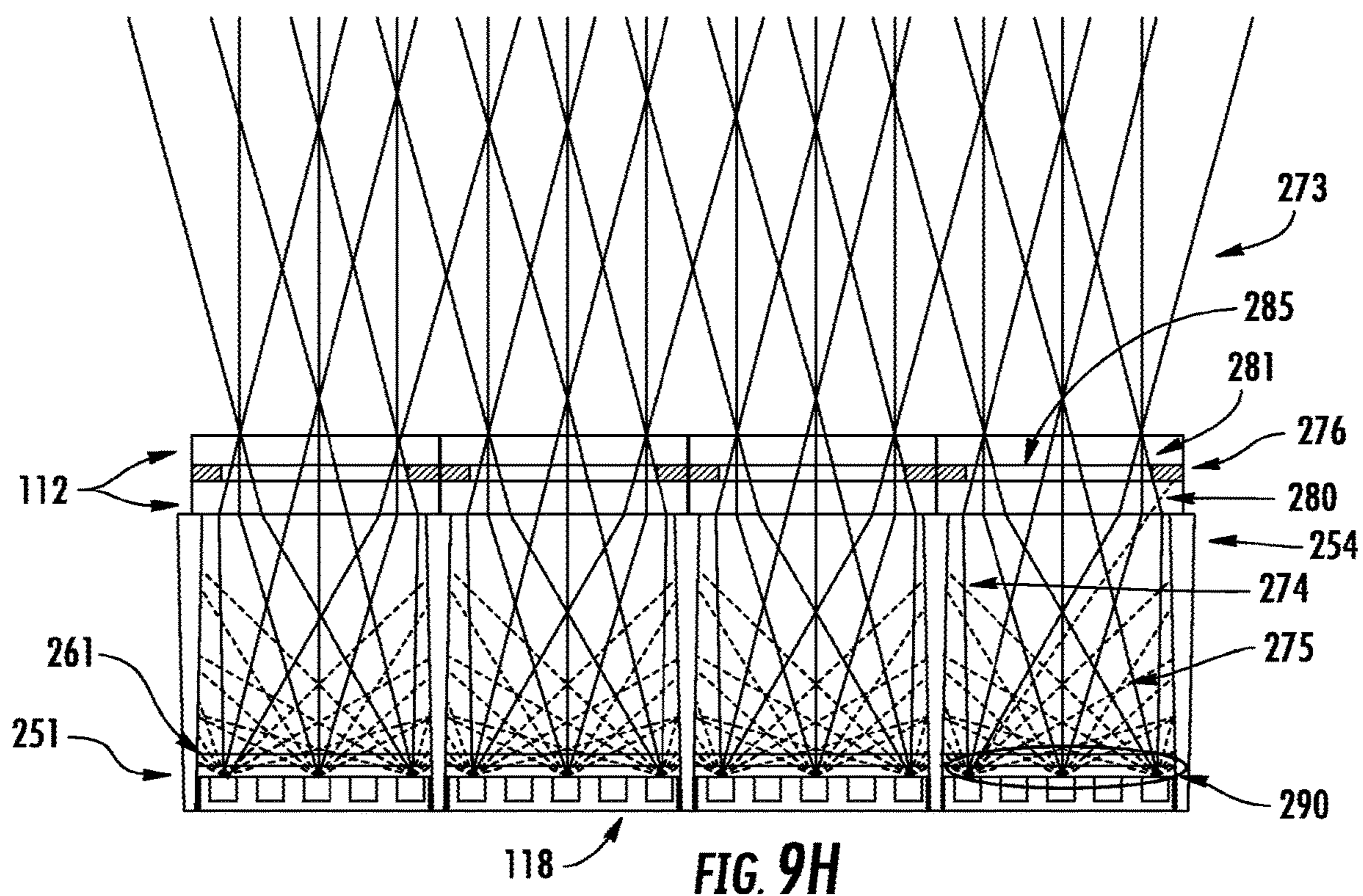
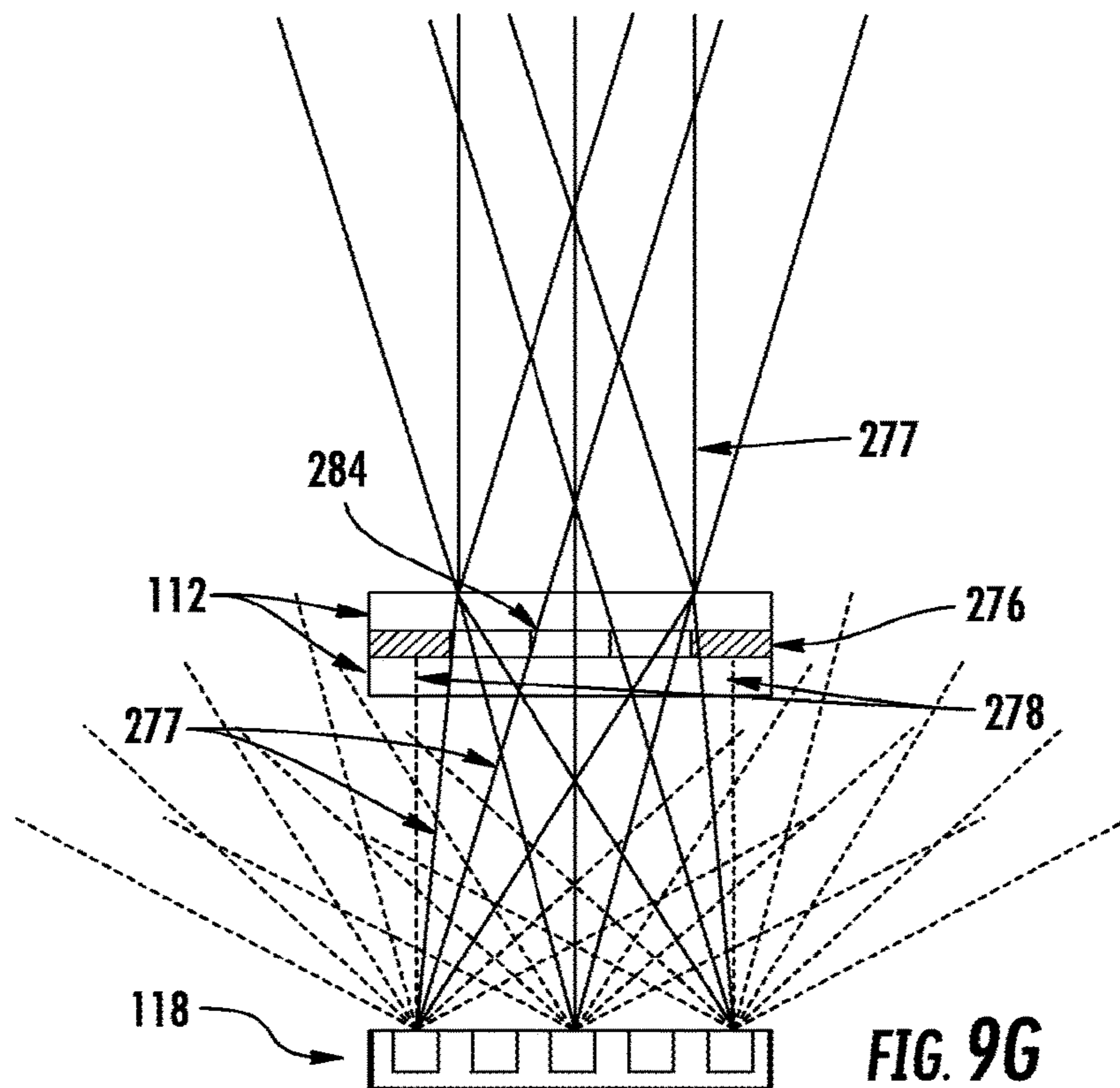

FIG. 9F



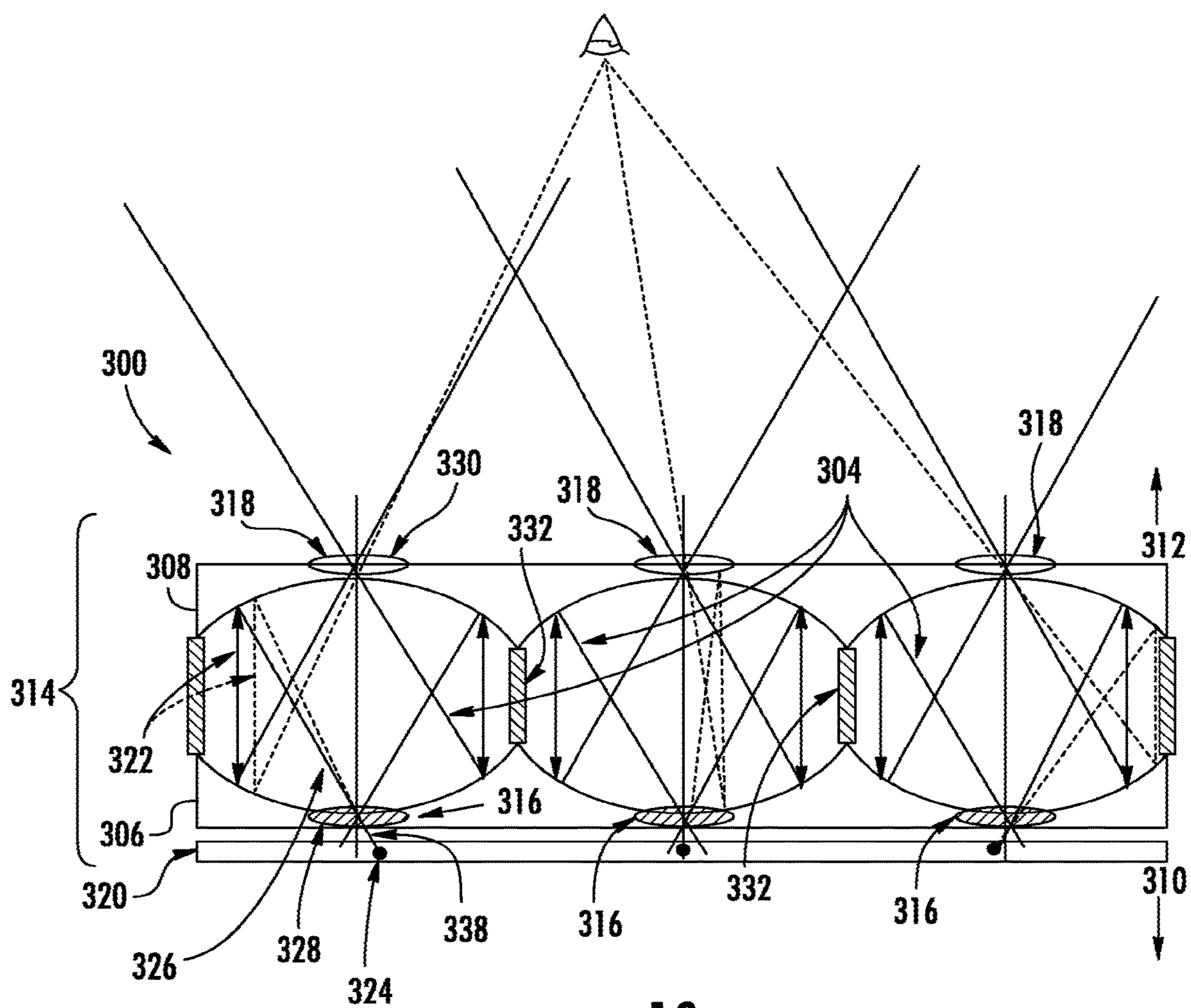

FIG. 10

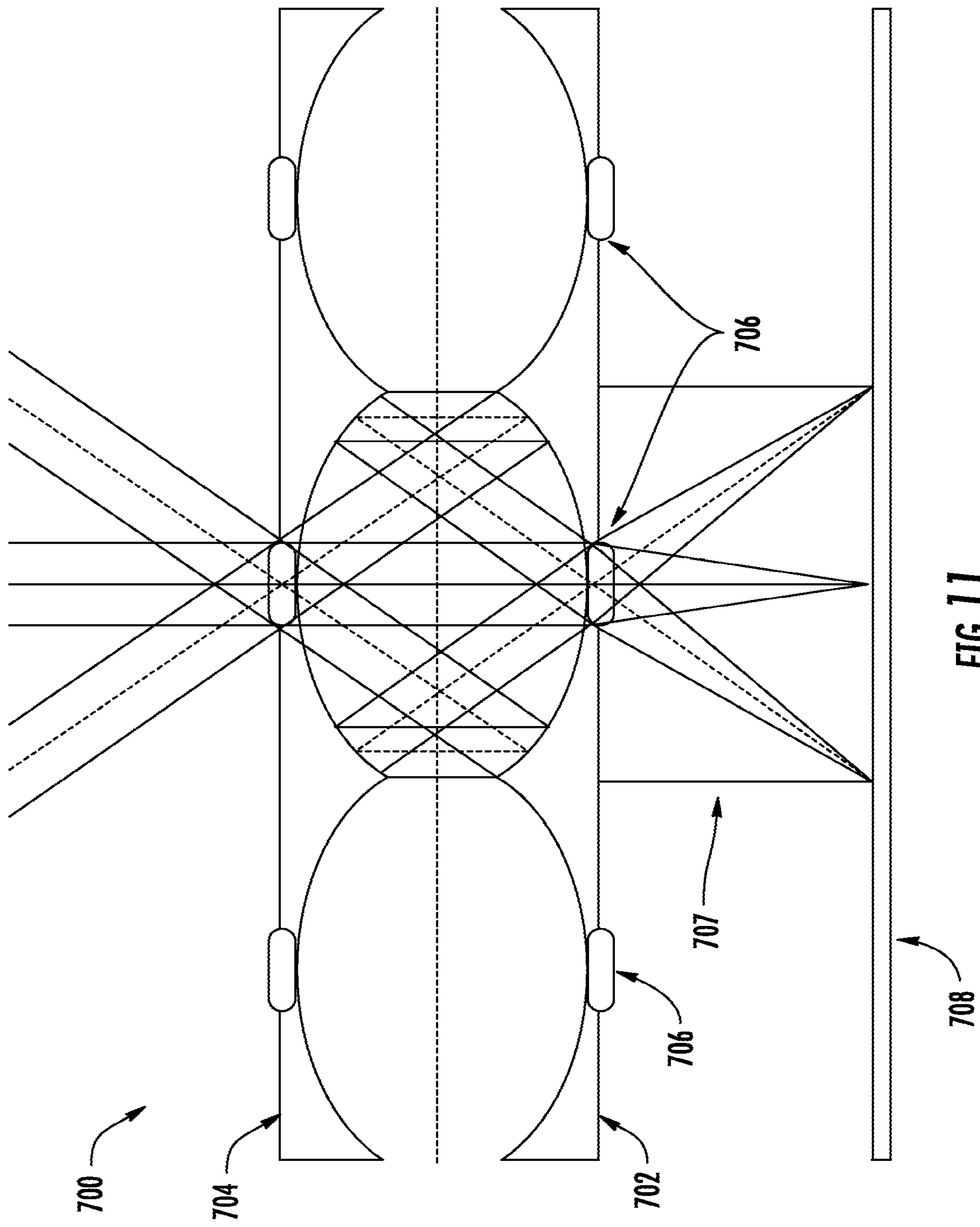

FIG. 11

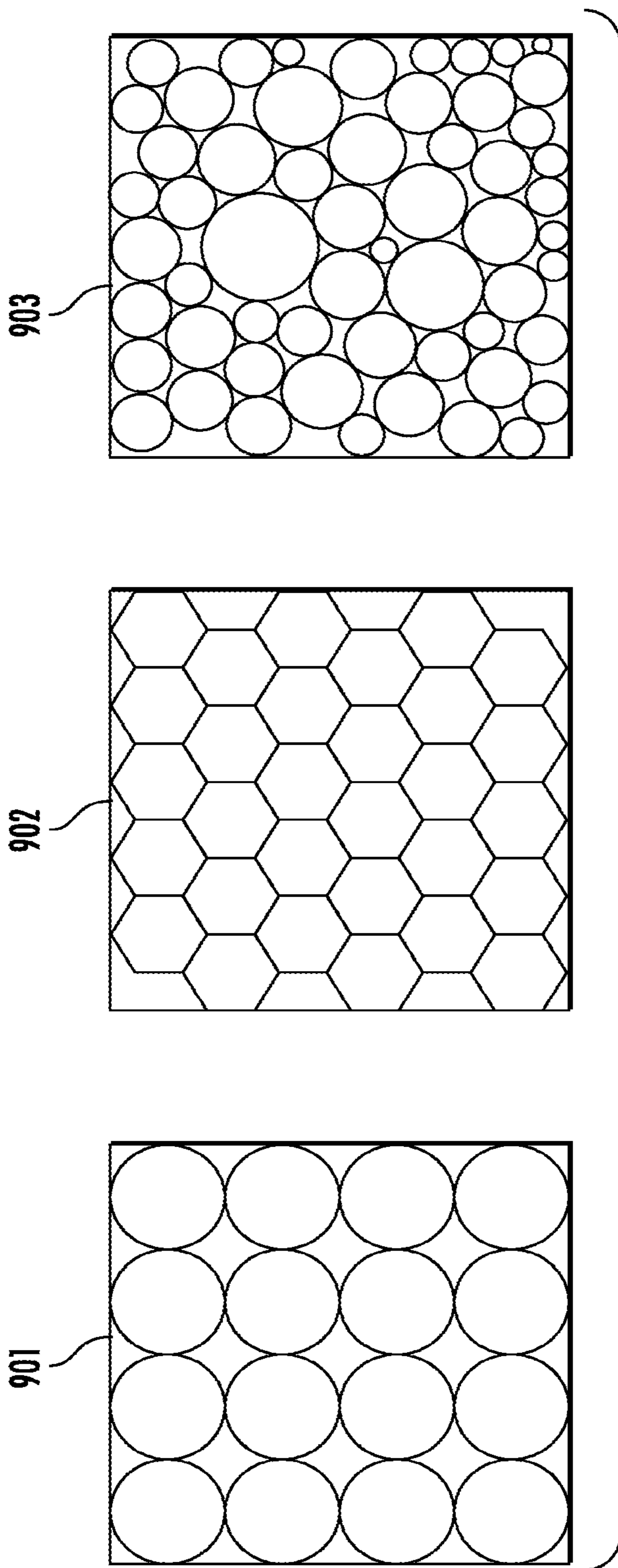

FIG. 12

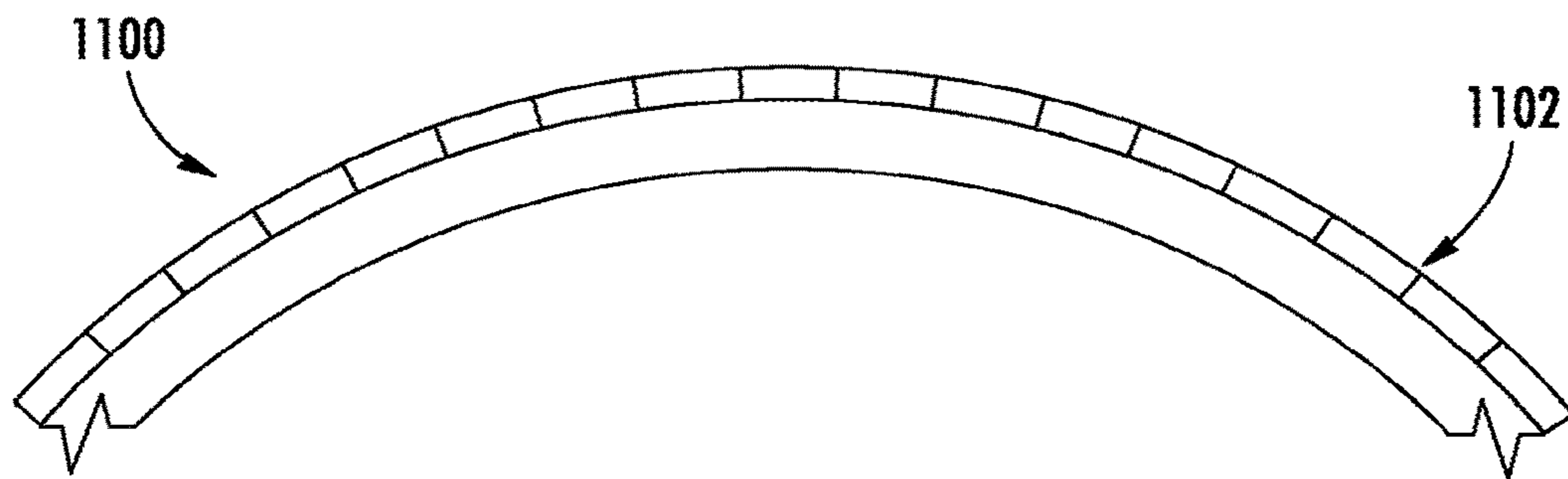

FIG. 13

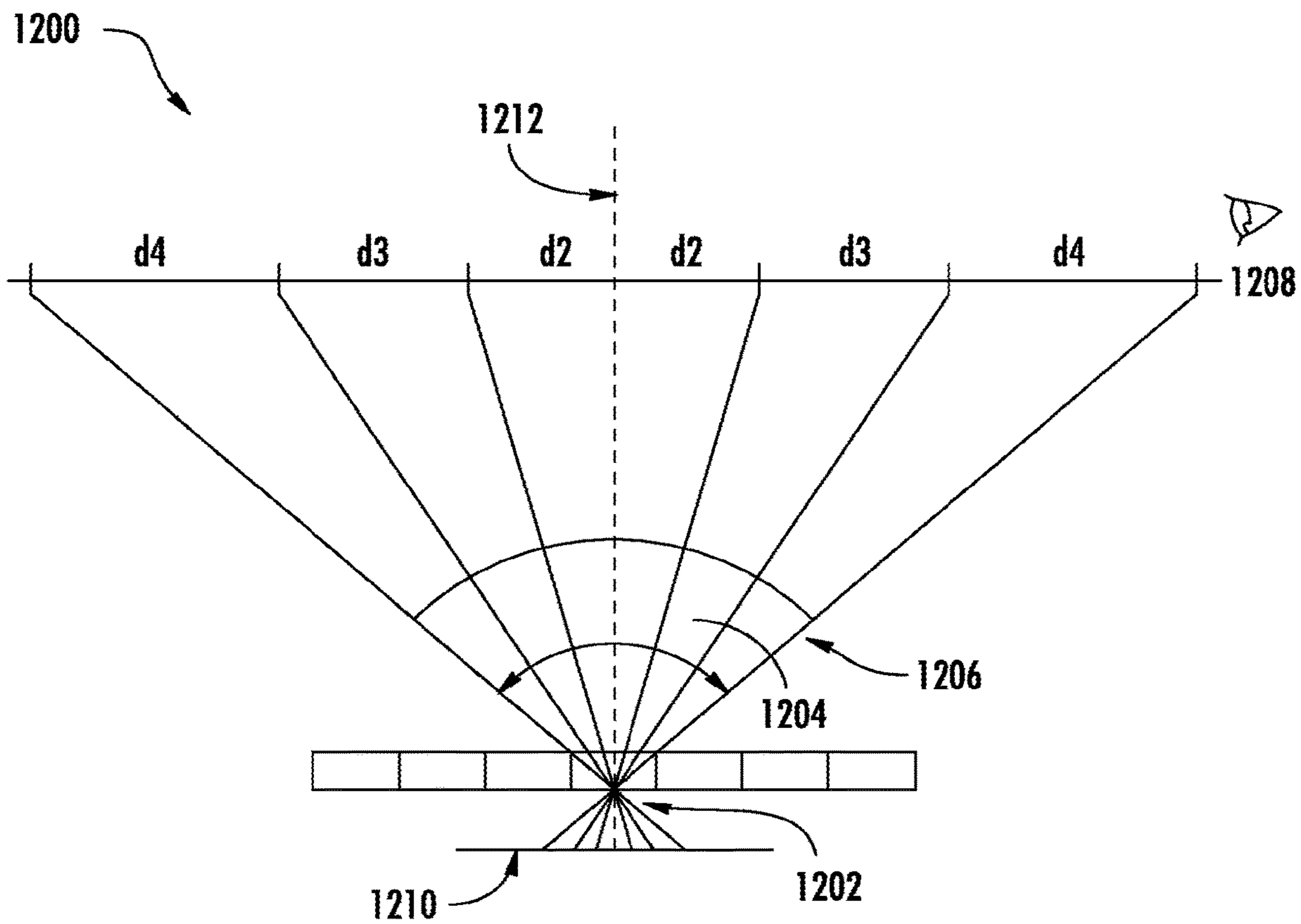

FIG. 14

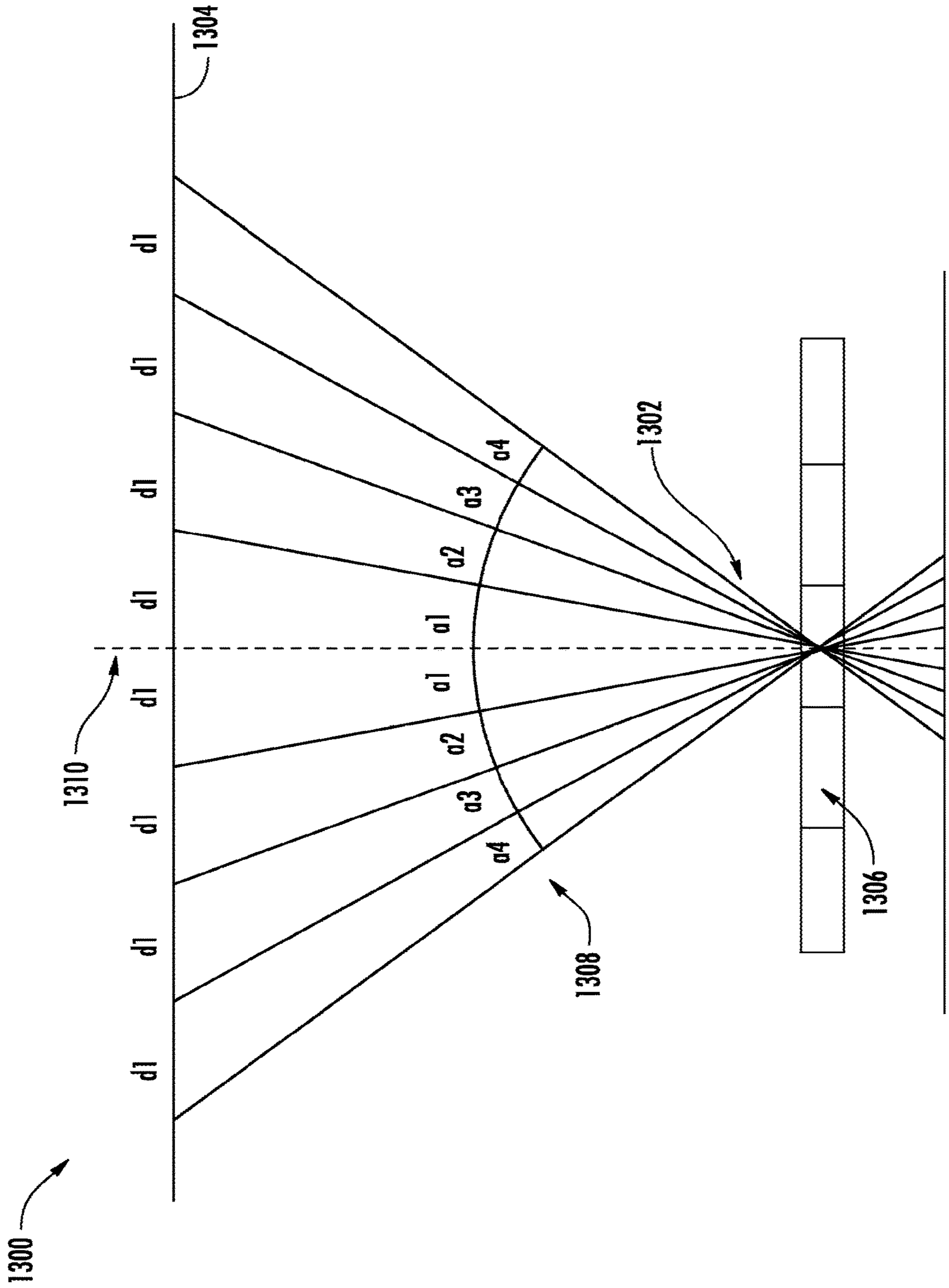

FIG. 15

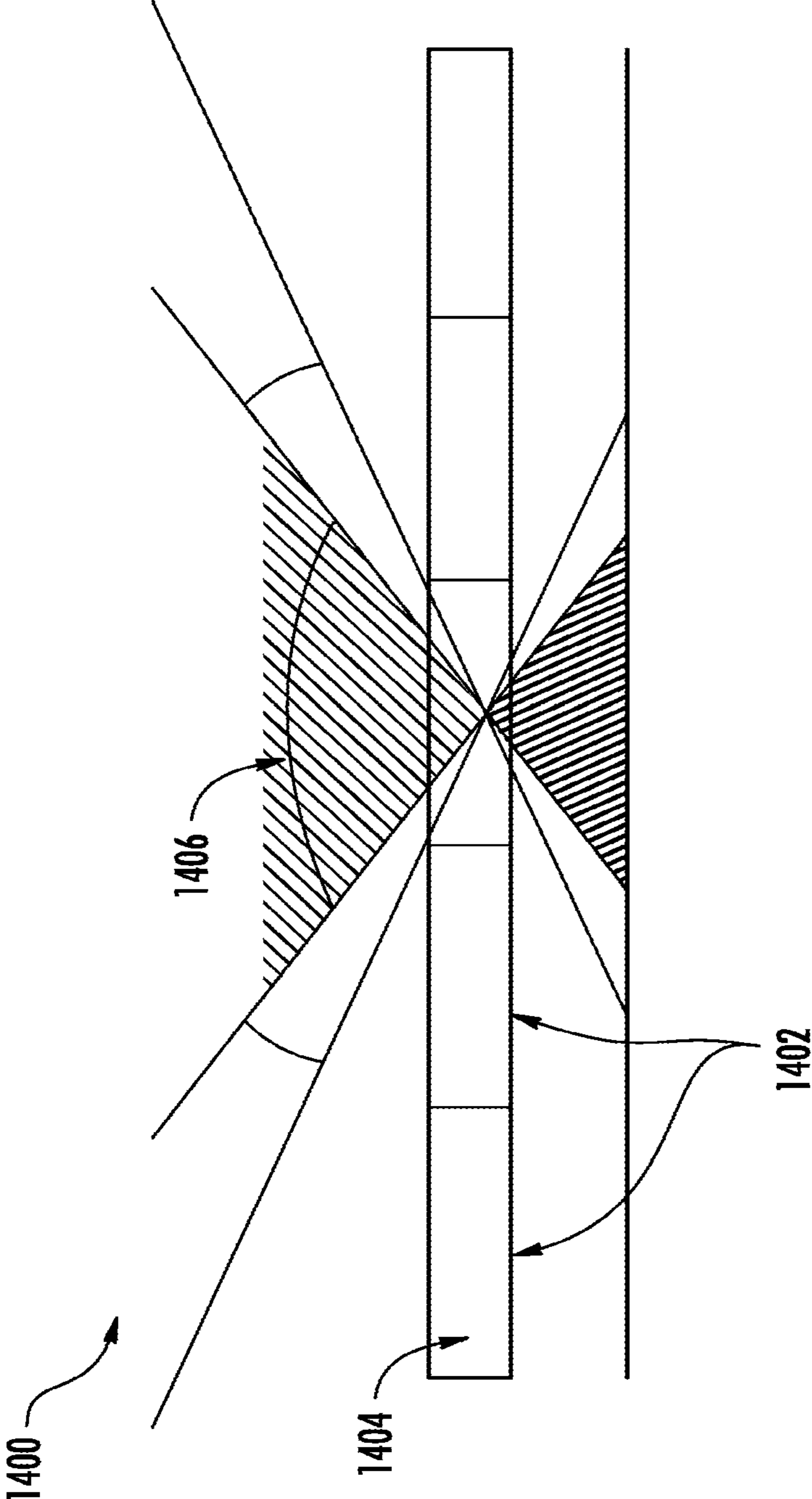

FIG. 16

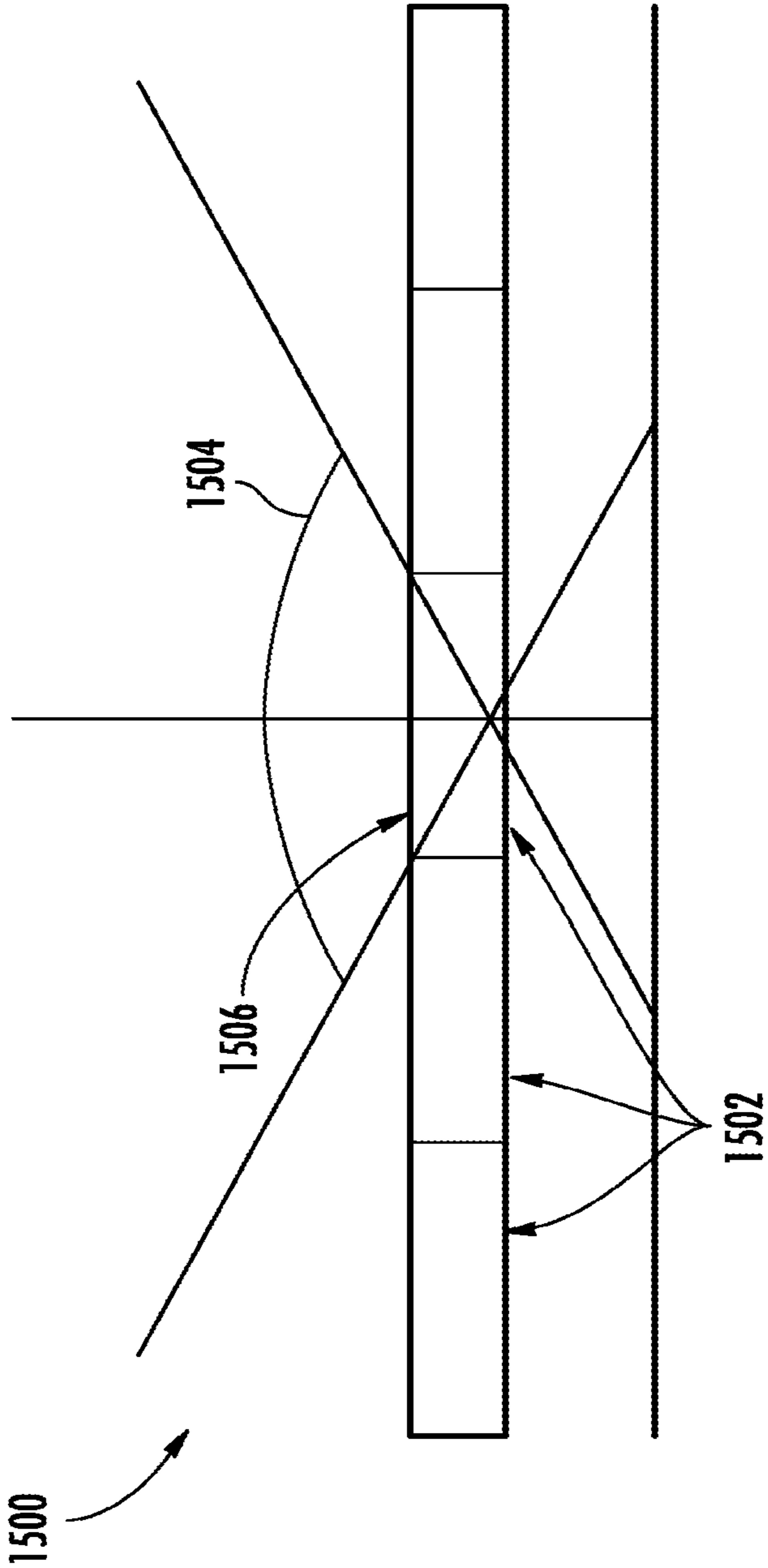

FIG. 17

**SELECTIVE PROPAGATION OF ENERGY IN
LIGHT FIELD AND HOLOGRAPHIC
WAVEGUIDE ARRAYS**

TECHNICAL FIELD

[0001] This disclosure is related to energy directing devices, and specifically to energy waveguides configured to direct energy in accordance with a four-dimensional plenoptic system.

BACKGROUND

[0002] The dream of an interactive virtual world within a “holodeck” chamber as popularized by Gene Roddenberry’s Star Trek and originally envisioned by author Alexander Moszkowski in the early 1900s has been the inspiration for science fiction and technological innovation for nearly a century. However, no compelling implementation of this experience exists outside of literature, media, and the collective imagination of children and adults alike.

SUMMARY

[0003] An embodiment of an energy waveguide system for defining a plurality of energy propagation paths comprises an array of energy waveguides, the array comprising a first side and a second side, and being configured to direct energy therethrough along a plurality of energy propagation paths extending through a plurality of energy locations on the first side. A subset of the plurality of energy propagation paths may extend through a first energy location.

[0004] In an embodiment, a first energy waveguide is configured to direct energy along a first energy propagation path of the first subset of the plurality of energy propagation paths, the first energy propagation path defined by a first chief ray formed between the first energy location and the first energy waveguide, and further wherein the first energy propagation path extends from the first energy waveguide towards the second side of the array in a unique direction which is determined at least by the first energy location. Energy directed along the first energy propagation path through the first energy waveguide may substantially fill a first aperture of the first energy waveguide. In an embodiment, the energy waveguide system comprises an energy inhibiting element positioned to limit propagation of energy along a portion of the first subset of the plurality of energy propagation paths that do not extend through the first aperture.

[0005] In an embodiment, the energy inhibiting element may be located on the first side between the array of energy waveguides and the plurality of energy locations. In an embodiment, the first energy waveguide comprises a two-dimensional spatial coordinate, and wherein the unique direction determined at least by the first energy location comprises a two-dimensional angular coordinate, whereby the 2D spatial coordinate and the 2D angular coordinate form a four-dimensional (4D) coordinate set.

[0006] In an embodiment, energy directed along the first energy propagation path may comprise one or more energy rays directed through the first energy waveguide in a direction that is substantially parallel to the first chief ray.

[0007] In an embodiment, energy directed along the first energy propagation path may converge with energy directed along a second energy propagation path through a second energy waveguide. Furthermore, the first and second energy

propagation paths may converge on the second side of the array, the first side of the array, or between the first and second sides of the array.

[0008] Furthermore, the structure of the energy inhibiting element may be configured to limit an angular extent of energy proximate the first energy location may comprise an energy relay adjacent to the first energy location. Additionally, the energy inhibiting structure may comprise at least one numerical aperture, and may comprise a baffle structure. The energy inhibiting structure may be positioned adjacent to the first energy waveguide and generally extends towards the first energy location, or may be positioned adjacent to the first energy location and generally extends towards the first energy waveguide.

[0009] In an embodiment, the array of energy waveguides may be arranged to form a planar surface, or may be arranged to form a curved surface.

[0010] An embodiment of an energy waveguide system for defining a plurality of energy propagation paths may comprise an array of lenslets, the array comprising a first side and a second side, and being configured to direct energy therethrough along a plurality of energy propagation paths extending through a plurality of energy locations. A first subset of the plurality of energy propagation paths extend through a first energy location.

[0011] In an embodiment, a first lenslet is configured to direct energy along a first energy propagation path of the first subset of the plurality of energy propagation paths, the first energy propagation path defined by a first chief ray formed between the first energy location and the first lenslet, and further wherein the first energy propagation path extends from the first energy waveguide towards the second side of the array in a unique direction which is determined at least by the first energy location. Energy directed along the first energy propagation path through the first lenslet substantially may fill a first aperture of the first lenslet.

[0012] In an embodiment, the energy waveguide system comprises an energy inhibiting element positioned to limit propagation of energy along a portion of the first subset of the plurality of energy propagation paths that do not extend through the first aperture. In an embodiment, the array of waveguides may be arranged to form a planar surface, or may be arranged to form a curved surface.

[0013] In an embodiment, an element of the array of waveguides may be a Fresnel lens.

[0014] In an embodiment, a shape of the first waveguide may be configured to additionally alter the unique direction that is determined at least by the first energy location.

[0015] An embodiment of an energy waveguide system for defining a plurality of energy propagation paths comprises a reflector element comprising a first reflector located on a first side of the reflector element, the first reflector comprising one or more aperture stops formed therethrough, and a second reflector located on a second side of the reflector element, the second reflector comprising one or more aperture stops formed therethrough. The first and second reflectors are configured to direct energy along a plurality of energy propagation paths extending through the aperture stops of the first and second reflectors and a plurality of energy locations on the first side of the reflector element. A first subset of the plurality of energy propagation paths may extend through a first energy location.

[0016] In an embodiment, the reflector element is configured to direct energy along a first energy propagation path of

the first subset of the plurality of energy propagation paths, the first energy propagation path defined by a first chief ray formed between the first energy location and a first aperture stop of the first reflector, and further wherein the first energy propagation path extends from a first aperture stop of the second reflector towards the second side of the reflector element in a unique direction which is determined at least by the first energy location. Energy directed along the first energy propagation path may substantially fill the first aperture stop of the first reflector and the first aperture stop of the second reflector

[0017] In an embodiment, the energy waveguide system comprises an energy inhibiting element positioned to limit propagation of energy along a portion of the first subset of the plurality of energy propagation paths that do not extend through the first aperture stop of the first reflector.

[0018] In an embodiment, a size of the one or more aperture stops of the first and second reflectors may be constant, or may vary.

[0019] In an embodiment, the first and second reflectors comprise one or more parabolic surfaces, such that a first parabolic surface of the first reflector and a first parabolic surface of the second reflector are configured to reflect energy along the first energy propagation path. A focal length of the first parabolic surface of the first reflector may be the same as a focal length of the first parabolic surface of the second reflector, or may be different than a focal length of the first parabolic surface of the second reflector.

[0020] In an embodiment, an additional energy inhibiting element may be located between the first and second sides of the reflector element.

[0021] In an embodiment, the energy waveguide systems propagate energy bidirectionally.

[0022] In an embodiment, the energy waveguides are configured for propagation of mechanical energy.

[0023] In an embodiment, the energy waveguides are configured for propagation of electromagnetic energy.

[0024] In an embodiment, the energy waveguides are configured for simultaneous propagation of mechanical, electromagnetic and/or other forms of energy.

[0025] In an embodiment, the energy waveguides propagate energy with differing ratios for u and v respectively within a 4D coordinate system.

[0026] In an embodiment, the energy waveguides propagate energy with an anamorphic function.

[0027] In an embodiment, the energy waveguides comprise multiple elements along the energy propagation path.

[0028] In an embodiment, the energy waveguides are directly formed from optical fiber relay polished surfaces.

[0029] In an embodiment, the energy waveguide system comprises materials exhibiting Transverse Anderson Localization.

[0030] In an embodiment, the energy inhibiting elements are configured for inhibiting electromagnetic energy

[0031] In an embodiment, the energy inhibiting elements are configured for inhibiting mechanical energy

[0032] In an embodiment, the energy inhibiting elements are configured for inhibiting mechanical, electromagnetic and/or other forms of energy.

[0033] These and other advantages of the present disclosure will become apparent to those skilled in the art from the following detailed description and the appended claims.

BRIEF DESCRIPTION OF THE DRAWINGS

[0034] FIG. 1 is a schematic diagram illustrating design parameters for an energy directing system;

[0035] FIG. 2 is a schematic diagram illustrating an energy system having an active device area with a mechanical envelope;

[0036] FIG. 3 is a schematic diagram illustrating an energy relay system;

[0037] FIG. 4 is a schematic diagram illustrating an embodiment of energy relay elements adhered together and fastened to a base structure;

[0038] FIG. 5A is a schematic diagram illustrating an example of a relayed image through multi-core optical fibers;

[0039] FIG. 5B is a schematic diagram illustrating an example of a relayed image through an optical relay that exhibits the properties of the Transverse Anderson Localization principle;

[0040] FIG. 6 is a schematic diagram showing rays propagated from an energy surface to a viewer;

[0041] FIG. 7 illustrates a top-down perspective view of an embodiment of an energy waveguide system operable to define a plurality of energy propagation paths;

[0042] FIG. 8 illustrates a front perspective view of the embodiment shown in FIG. 7;

[0043] FIGS. 9A-H illustrate various embodiments of an energy inhibiting element;

[0044] FIG. 10 illustrates an additional embodiment of an energy waveguide system;

[0045] FIG. 11 illustrates an additional embodiment of an energy waveguide system;

[0046] FIG. 12 highlights the differences between square packing, hex packing and irregular packing for energy waveguide design considerations;

[0047] FIG. 13 illustrates an embodiment featuring an array of energy waveguides arranged in a curved configuration;

[0048] FIG. 14 illustrates an embodiment that highlights how a waveguide element may affect a spatial distribution of energy passing therethrough;

[0049] FIG. 15 illustrates an additional embodiment which further highlights how a waveguide element may affect a spatial distribution of energy passing therethrough;

[0050] FIG. 16 illustrates an embodiment wherein the plurality of energy waveguides comprise diffractive waveguide elements;

[0051] FIG. 17 illustrates a lenslet configuration used to provide full density of ray illumination for the desired angle of view.

DETAILED DESCRIPTION

[0052] An embodiment of a Holodeck (collectively called "Holodeck Design Parameters") provide sufficient energy stimulus to fool the human sensory receptors into believing that received energy impulses within a virtual, social and interactive environment are real, providing: 1) binocular disparity without external accessories, head-mounted eye-wear, or other peripherals; 2) accurate motion parallax, occlusion and opacity throughout a viewing volume simultaneously for any number of viewers; 3) visual focus through synchronous convergence, accommodation and miosis of the eye for all perceived rays of light; and 4) converging energy wave propagation of sufficient density

and resolution to exceed the human sensory “resolution” for vision, hearing, touch, taste, smell, and/or balance.

[0053] Based upon conventional technology to date, we are decades, if not centuries away from a technology capable of providing for all receptive fields in a compelling way as suggested by the Holodeck Design Parameters including the visual, auditory, somatosensory, gustatory, olfactory, and vestibular systems.

[0054] In this disclosure, the terms light field and holographic may be used interchangeably to define the energy propagation for stimulation of any sensory receptor response. While initial disclosures may refer to examples of electromagnetic and mechanical energy propagation through energy surfaces for holographic imagery and volumetric haptics, all forms of sensory receptors are envisioned in this disclosure. Furthermore, the principles disclosed herein for energy propagation along propagation paths may be applicable to both energy emission and energy capture.

[0055] Many technologies exist today that are often unfortunately confused with holograms including lenticular printing, Pepper’s Ghost, glasses-free stereoscopic displays, horizontal parallax displays, head-mounted VR and AR displays (HMD), and other such illusions generalized as “fauxlography.” These technologies may exhibit some of the desired properties of a true holographic display, however, lack the ability to stimulate the human visual sensory response in any way sufficient to address at least two of the four identified Holodeck Design Parameters.

[0056] These challenges have not been successfully implemented by conventional technology to produce a seamless energy surface sufficient for holographic energy propagation. There are various approaches to implementing volumetric and direction multiplexed light field displays including parallax barriers, hogels, voxels, diffractive optics, multi-view projection, holographic diffusers, rotational mirrors, multilayered displays, time sequential displays, head mounted display, etc., however, conventional approaches may involve a compromise on image quality, resolution, angular sampling density, size, cost, safety, frame rate, etc., ultimately resulting in an unviable technology.

[0057] To achieve the Holodeck Design Parameters for the visual, auditory, somatosensory systems, the human acuity of each of the respective systems is studied and understood to propagate energy waves to sufficiently fool the human sensory receptors. The visual system is capable of resolving to approximately 1 arc min, the auditory system may distinguish the difference in placement as little as three degrees, and the somatosensory system at the hands are capable of discerning points separated by 2-12 mm. While there are various and conflicting ways to measure these acuities, these values are sufficient to understand the systems and methods to stimulate perception of energy propagation.

[0058] Of the noted sensory receptors, the human visual system is by far the most sensitive given that even a single photon can induce sensation. For this reason, much of this introduction will focus on visual energy wave propagation, and vastly lower resolution energy systems coupled within a disclosed energy waveguide surface may converge appropriate signals to induce holographic sensory perception. Unless otherwise noted, all disclosures apply to all energy and sensory domains.

[0059] When calculating for effective design parameters of the energy propagation for the visual system given a viewing volume and viewing distance, a desired energy

surface may be designed to include many gigapixels of effective energy location density. For wide viewing volumes, or near field viewing, the design parameters of a desired energy surface may include hundreds of gigapixels or more of effective energy location density. By comparison, a desired energy source may be designed to have 1 to 250 effective megapixels of energy location density for ultrasonic propagation of volumetric haptics or an array of 36 to 3,600 effective energy locations for acoustic propagation of holographic sound depending on input environmental variables. What is important to note is that with a disclosed bidirectional energy surface architecture, all components may be configured to form the appropriate structures for any energy domain to enable holographic propagation.

[0060] However, the main challenge to enable the Holodeck today involves available visual technologies and electromagnetic device limitations. Acoustic and ultrasonic devices are less challenging given the orders of magnitude difference in desired density based upon sensory acuity in the respective receptive field, although the complexity should not be underestimated. While holographic emulsion exists with resolutions exceeding the desired density to encode interference patterns in static imagery, state-of-the-art display devices are limited by resolution, data throughput and manufacturing feasibility. To date, no singular display device has been able to meaningfully produce a light field having near holographic resolution for visual acuity.

[0061] Production of a single silicon-based device capable of meeting the desired resolution for a compelling light field display may not be practical and may involve extremely complex fabrication processes beyond the current manufacturing capabilities. The limitation to tiling multiple existing display devices together involves the seams and gap formed by the physical size of packaging, electronics, enclosure, optics and a number of other challenges that inevitably result in an unviable technology from an imaging, cost and/or a size standpoint.

[0062] The embodiments disclosed herein may provide a real-world path to building the Holodeck.

[0063] Example embodiments will now be described hereinafter with reference to the accompanying drawings, which form a part hereof, and which illustrate example embodiments which may be practiced. As used in the disclosures and the appended claims, the terms “embodiment”, “example embodiment”, and “exemplary embodiment” do not necessarily refer to a single embodiment, although they may, and various example embodiments may be readily combined and interchanged, without departing from the scope or spirit of example embodiments. Furthermore, the terminology as used herein is for the purpose of describing example embodiments only and is not intended to be limitations. In this respect, as used herein, the term “in” may include “in” and “on”, and the terms “a,” “an” and “the” may include singular and plural references. Furthermore, as used herein, the term “by” may also mean “from”, depending on the context. Furthermore, as used herein, the term “if” may also mean “when” or “upon,” depending on the context. Furthermore, as used herein, the words “and/or” may refer to and encompass any and all possible combinations of one or more of the associated listed items.

Holographic System Considerations

Overview of Light Field Energy Provocation Resolution

[0064] Light field and holographic display is the result of a plurality of projections where energy surface locations provide angular, color and intensity information propagated within a viewing volume. The disclosed energy surface provides opportunities for additional information to coexist and propagate through the same surface to induce other sensory system responses. Unlike a stereoscopic display, the viewed position of the converged energy propagation paths in space do not vary as the viewer moves around the viewing volume and any number of viewers may simultaneously see propagated objects in real-world space as if it was truly there. In some embodiments, the propagation of energy may be located in the same energy propagation path but in opposite directions. For example, energy emission and energy capture along an energy propagation path are both possible in some embodiments of the present disclosed.

[0065] FIG. 1 is a schematic diagram illustrating variables relevant for stimulation of sensory receptor response. These variables may include surface diagonal **01**, surface width **02**, surface height **03**, a determined target seating distance **18**, the target seating field of view from the center of the display **04**, the number of intermediate samples demonstrated here as samples between the eyes **05**, the average adult inter-ocular separation **06**, the average resolution of the human eye in arcmin **07**, the horizontal field of view formed between the target viewer location and the surface width **08**, the vertical field of view formed between the target viewer location and the surface height **09**, the resultant horizontal waveguide element resolution, or total number of elements, across the surface **10**, the resultant vertical waveguide element resolution, or total number of elements, across the surface **11**, the sample distance based upon the inter-ocular spacing between the eyes and the number of intermediate samples for angular projection between the eyes **12**. The angular sampling may be based upon the sample distance and the target seating distance **13**, the total resolution Horizontal per waveguide element derived from the angular sampling desired **14**, the total resolution Vertical per waveguide element derived from the angular sampling desired **15**. Device Horizontal is the count of the determined number of discreet energy sources desired **16**, and device Vertical is the count of the determined number of discreet energy sources desired **17**.

[0066] A method to understand the desired minimum resolution may be based upon the following criteria to ensure sufficient stimulation of visual (or other) sensory receptor response: surface size (e.g., 84" diagonal), surface aspect ratio (e.g., 16:9), seating distance (e.g., 128" from the display), seating field of view (e.g., 120 degrees or +1-60 degrees about the center of the display), desired intermediate samples at a distance (e.g., one additional propagation path between the eyes), the average inter-ocular separation of an adult (approximately 65 mm), and the average resolution of the human eye (approximately 1 arcmin). These example values should be considered placeholders depending on the specific application design parameters.

[0067] Further, each of the values attributed to the visual sensory receptors may be replaced with other systems to determine desired propagation path parameters. For other energy propagation embodiments, one may consider the

auditory system's angular sensitivity as low as three degrees, and the somatosensory system's spatial resolution of the hands as small as 2-12 mm.

[0068] While there are various and conflicting ways to measure these sensory acuities, these values are sufficient to understand the systems and methods to stimulate perception of virtual energy propagation. There are many ways to consider the design resolution, and the below proposed methodology combines pragmatic product considerations with the biological resolving limits of the sensory systems. As will be appreciated by one of ordinary skill in the art, the following overview is a simplification of any such system design, and should be considered for exemplary purposes only.

[0069] With the resolution limit of the sensory system understood, the total energy waveguide element density may be calculated such that the receiving sensory system cannot discern a single energy waveguide element from an adjacent element, given:

$$\text{Surface Aspect Ratio} = \frac{\text{Width } (W)}{\text{Height } (H)}$$

$$\text{Surface Horizontal Size} = \text{Surface Diagonal} * \left(\frac{1}{\sqrt{1 + \left(\frac{H}{W}\right)^2}} \right)$$

$$\text{Surface Vertical Size} = \text{Surface Diagonal} * \left(\frac{1}{\sqrt{1 + \left(\frac{W}{H}\right)^2}} \right)$$

$$\text{Horizontal Field of View} = 2 * \text{atan} \left(\frac{\text{Surface Horizontal Size}}{2 * \text{Seating Distance}} \right)$$

$$\text{Vertical Field of View} = 2 * \text{atan} \left(\frac{\text{Surface Vertical Size}}{2 * \text{Seating Distance}} \right)$$

$$\text{Horizontal Element Resolution} = \text{Horizontal FoV} * \frac{60}{\text{Eye Resolution}}$$

$$\text{Vertical Element Resolution} = \text{Vertical FoV} * \frac{60}{\text{Eye Resolution}}$$

[0070] The above calculations result in approximately a 32×18° field of view resulting in approximately 1920×1080 (rounded to nearest format) energy waveguide elements being desired. One may also constrain the variables such that the field of view is consistent for both (u, v) to provide a more regular spatial sampling of energy locations (e.g. pixel aspect ratio). The angular sampling of the system assumes a defined target viewing volume location and additional propagated energy paths between two points at the optimized distance, given:

$$\text{Sample Distance} = \frac{\text{Inter-Ocular Distance}}{(\text{Number of Desired Intermediate Samples} + 1)}$$

$$\text{Angular Sampling} = \text{atan} \left(\frac{\text{Sample Distance}}{\text{Seating Distance}} \right)$$

[0071] In this case, the inter-ocular distance is leveraged to calculate the sample distance although any metric may be leveraged to account for appropriate number of samples as a given distance. With the above variables considered,

approximately one ray per 0.57° may be desired and the total system resolution per independent sensory system may be determined, given:

$$\text{Locations Per Element}(N) = \frac{\text{Seating } FoV}{\text{Angular Sampling}}$$

$$\text{Total Resolution } H = N * \text{Horizontal Element Resolution}$$

$$\text{Total Resolution } V = N * \text{Vertical Element Resolution}$$

[0072] With the above scenario given the size of energy surface and the angular resolution addressed for the visual acuity system, the resultant energy surface may desirably include approximately $400k \times 225k$ pixels of energy resolution locations, or 90 gigapixels holographic propagation density. These variables provided are for exemplary purposes only and many other sensory and energy metrology considerations should be considered for the optimization of holographic propagation of energy. In an additional embodiment, 1 gigapixel of energy resolution locations may be desired based upon the input variables. In an additional embodiment, 1,000 gigapixels of energy resolution locations may be desired based upon the input variables.

Current Technology Limitations

Active Area, Device Electronics, Packaging, and the Mechanical Envelope

[0073] FIG. 2 illustrates a device 20 having an active area 22 with a certain mechanical form factor. The device 20 may include drivers 23 and electronics 24 for powering and interface to the active area 22, the active area having a dimension as shown by the x and y arrows. This device 20 does not take into account the cabling and mechanical structures to drive, power and cool components, and the mechanical footprint may be further minimized by introducing a flex cable into the device 20. The minimum footprint for such a device 20 may also be referred to as a mechanical envelope 21 having a dimension as shown by the M:x and M:y arrows. This device 20 is for illustration purposes only and custom electronics designs may further decrease the mechanical envelope overhead, but in almost all cases may not be the exact size of the active area of the device. In an embodiment, this device 20 illustrates the dependency of electronics as it relates to active image area 22 for a micro OLED, DLP chip or LCD panel, or any other technology with the purpose of image illumination.

[0074] In some embodiments, it may also be possible to consider other projection technologies to aggregate multiple images onto a larger overall display. However, this may come at the cost of greater complexity for throw distance, minimum focus, optical quality, uniform field resolution, chromatic aberration, thermal properties, calibration, alignment, additional size or form factor. For most practical applications, hosting tens or hundreds of these projection sources 20 may result in a design that is much larger with less reliability.

[0075] For exemplary purposes only, assuming energy devices with an energy location density of 3840×2160 sites, one may determine the number of individual energy devices (e.g., device 10) desired for an energy surface, given:

$$\text{Devices } H = \frac{\text{Total Resolution } H}{\text{Device Resolution } H}$$

$$\text{Devices } V = \frac{\text{Total Resolution } V}{\text{Device Resolution } V}$$

[0076] Given the above resolution considerations, approximately 105×105 devices similar to those shown in FIG. 2 may be desired. It should be noted that many devices consist of various pixel structures that may or may not map to a regular grid. In the event that there are additional sub-pixels or locations within each full pixel, these may be exploited to generate additional resolution or angular density. Additional signal processing may be used to determine how to convert the light field into the correct (u,v) coordinates depending on the specified location of the pixel structure(s) and can be an explicit characteristic of each device that is known and calibrated. Further, other energy domains may involve a different handling of these ratios and device structures, and those skilled in the art will understand the direct intrinsic relationship between each of the desired frequency domains. This will be shown and discussed in more detail in subsequent disclosure.

[0077] The resulting calculation may be used to understand how many of these individual devices may be desired to produce a full resolution energy surface. In this case, approximately 105×105 or approximately 11,080 devices may be desired to achieve the visual acuity threshold. The challenge and novelty exists within the fabrication of a seamless energy surface from these available energy locations for sufficient sensory holographic propagation.

Summary of Seamless Energy Surfaces

Configurations and Designs for Arrays of Energy Relays

[0078] In some embodiments, approaches are disclosed to address the challenge of generating high energy location density from an array of individual devices without seams due to the limitation of mechanical structure for the devices. In an embodiment, an energy propagating relay system may allow for an increase of the effective size of the active device area to meet or exceed the mechanical dimensions to configure an array of relays and form a singular seamless energy surface.

[0079] FIG. 3 illustrates an embodiment of such an energy relay system 30. As shown, the relay system 30 may include a device 31 mounted to a mechanical envelope 32, with an energy relay element 33 propagating energy from the device 31. The relay element 33 may be configured to provide the ability to mitigate any gaps 34 that may be produced when multiple mechanical envelopes 32 of the device are placed into an array of multiple devices 31.

[0080] For example, if a device's active area 310 is $20 \text{ mm} \times 10 \text{ mm}$ and the mechanical envelope 32 is $40 \text{ mm} \times 20 \text{ mm}$, an energy relay element 33 may be designed with a magnification of 2:1 to produce a tapered form that is approximately $20 \text{ mm} \times 10 \text{ mm}$ on a minified end (arrow A) and $40 \text{ mm} \times 20 \text{ mm}$ on a magnified end (arrow B), providing the ability to align an array of these elements 33 together seamlessly without altering or colliding with the mechanical envelope 32 of each device 31. Mechanically, the relay elements 33 may be bonded or fused together to align and

polish ensuring minimal seam gap **34** between devices **31**. In one such embodiment, it is possible to achieve a seam gap **34** smaller than the visual acuity limit of the eye.

[0081] FIG. 4 illustrates an example of a base structure **400** having energy relay elements **410** formed together and securely fastened to an additional mechanical structure **430**. The mechanical structure of the seamless energy surface **420** provides the ability to couple multiple energy relay elements **410**, **450** in series to the same base structure through bonding or other mechanical processes to mount relay elements **410**, **450**. In some embodiments, each relay element **410** may be fused, bonded, adhered, pressure fit, aligned or otherwise attached together to form the resultant seamless energy surface **420**. In some embodiments, a device **480** may be mounted to the rear of the relay element **410** and aligned passively or actively to ensure appropriate energy location alignment within the determined tolerance is maintained.

[0082] In an embodiment, the seamless energy surface comprises one or more energy locations and one or more energy relay element stacks comprise a first and second side and each energy relay element stack is arranged to form a singular seamless display surface directing energy along propagation paths extending between one or more energy locations and the seamless display surface, and where the separation between the edges of any two adjacent second sides of the terminal energy relay elements is less than the minimum perceptible contour as defined by the visual acuity of a human eye having better than 20/40 vision at a distance greater than the width of the singular seamless display surface.

[0083] In an embodiment, each of the seamless energy surfaces comprise one or more energy relay elements each with one or more structures forming a first and second surface with a transverse and longitudinal orientation. The first relay surface has an area different than the second resulting in positive or negative magnification and configured with explicit surface contours for both the first and second surfaces passing energy through the second relay surface to substantially fill a ± 10 degree angle with respect to the normal of the surface contour across the entire second relay surface.

[0084] In an embodiment, multiple energy domains may be configured within a single, or between multiple energy relays to direct one or more sensory holographic energy propagation paths including visual, acoustic, tactile or other energy domains.

[0085] In an embodiment, the seamless energy surface is configured with energy relays that comprise two or more first sides for each second side to both receive and emit one or more energy domains simultaneously to provide bidirectional energy propagation throughout the system.

[0086] In an embodiment, the energy relays are provided as loose coherent elements.

Introduction to Component Engineered Structures

Disclosed Advances in Transverse Anderson Localization Energy Relays

[0087] The properties of energy relays may be significantly optimized according to the principles disclosed herein for energy relay elements that induce Transverse Anderson Localization. Transverse Anderson Localization is the

propagation of a ray transported through a transversely disordered but longitudinally consistent material.

[0088] This implies that the effect of the materials that produce the Anderson Localization phenomena may be less impacted by total internal reflection than by the randomization between multiple-scattering paths where wave interference can completely limit the propagation in the transverse orientation while continuing in the longitudinal orientation.

[0089] Of significant additional benefit is the elimination of the cladding of traditional multi-core optical fiber materials. The cladding is to functionally eliminate the scatter of energy between fibers, but simultaneously act as a barrier to rays of energy thereby reducing transmission by at least the core to clad ratio (e.g., a core to clad ratio of 70:30 will transmit at best 70% of received energy transmission) and additionally forms a strong pixelated patterning in the propagated energy.

[0090] FIG. 5A illustrates an end view of an example of one such non-Anderson Localization energy relay **500**, wherein an image is relayed through multi-core optical fibers where pixilation and fiber noise may be exhibited due to the intrinsic properties of the optical fibers. With traditional multi-mode and multi-core optical fibers, relayed images may be intrinsically pixelated due to the properties of total internal reflection of the discrete array of cores where any cross-talk between cores will reduce the modulation transfer function and increase blurring. The resulting imagery produced with traditional multi-core optical fiber tends to have a residual fixed noise fiber pattern similar to those shown in FIG. 3.

[0091] FIG. 5B, illustrates an example of the same relayed image **550** through an energy relay comprising materials that exhibit the properties of Transverse Anderson Localization, where the relayed pattern has a greater density grain structures as compared to the fixed fiber pattern from FIG. 5A. In an embodiment, relays comprising randomized microscopic component engineered structures induce Transverse Anderson Localization and transport light more efficiently with higher propagation of resolvable resolution than commercially available multi-mode glass optical fibers.

[0092] There is significant advantage to the Transverse Anderson Localization material properties in terms of both cost and weight, where a similar optical grade glass material, may cost and weigh upwards of 10 to 100-fold more than the cost for the same material generated within an embodiment, wherein disclosed systems and methods comprise randomized microscopic component engineered structures demonstrating significant opportunities to improve both cost and quality over other technologies known in the art.

[0093] In an embodiment, a relay element exhibiting Transverse Anderson Localization may comprise a plurality of at least two different component engineered structures in each of three orthogonal planes arranged in a dimensional lattice and the plurality of structures form randomized distributions of material wave propagation properties in a transverse plane within the dimensional lattice and channels of similar values of material wave propagation properties in a longitudinal plane within the dimensional lattice, wherein localized energy waves propagating through the energy relay have higher transport efficiency in the longitudinal orientation versus the transverse orientation.

[0094] In an embodiment, multiple energy domains may be configured within a single, or between multiple Transverse Anderson Localization energy relays to direct one or

more sensory holographic energy propagation paths including visual, acoustic, tactile or other energy domains.

[0095] In an embodiment, the seamless energy surface is configured with Transverse Anderson Localization energy relays that comprise two or more first sides for each second side to both receive and emit one or more energy domains simultaneously to provide bidirectional energy propagation throughout the system.

[0096] In an embodiment, the Transverse Anderson Localization energy relays are configured as loose coherent or flexible energy relay elements.

Considerations for 4D Plenoptic Functions

Selective Propagation of Energy Through Holographic Waveguide Arrays

[0097] As discussed above and herein throughout, a light field display system generally includes an energy source (e.g., illumination source) and a seamless energy surface configured with sufficient energy location density as articulated in the above discussion. A plurality of relay elements may be used to relay energy from the energy devices to the seamless energy surface. Once energy has been delivered to the seamless energy surface with the requisite energy location density, the energy can be propagated in accordance with a 4D plenoptic function through a disclosed energy waveguide system. As will be appreciated by one of ordinary skill in the art, a 4D plenoptic function is well known in the art and will not be elaborated further herein.

[0098] The energy waveguide system selectively propagates energy through a plurality of energy locations along the seamless energy surface representing the spatial coordinate of the 4D plenoptic function with a structure configured to alter an angular direction of the energy waves passing through representing the angular component of the 4D plenoptic function, wherein the energy waves propagated may converge in space in accordance with a plurality of propagation paths directed by the 4D plenoptic function.

[0099] Reference is now made to FIG. 6 illustrating an example of light field energy surface in 4D image space in accordance with a 4D plenoptic function. The figure shows ray traces of an energy surface **600** to a viewer **620** in describing how the rays of energy converge in space **630** from various positions within the viewing volume. As shown, each waveguide element **610** defines four dimensions of information describing energy propagation **640** through the energy surface **600**. Two spatial dimensions (herein referred to as x and y) are the physical plurality of energy locations that can be viewed in image space, and the angular components theta and phi (herein referred to as u and v), which is viewed in virtual space when projected through the energy waveguide array. In general, and in accordance with a 4D plenoptic function, the plurality of waveguides (e.g., lenslets) are able to direct an energy location from the x, y dimension to a unique location in virtual space, along a direction defined by the u, v angular component, in forming the holographic or light field system described herein.

[0100] However, one skilled in the art will understand that a significant challenge to light field and holographic display technologies arises from uncontrolled propagation of energy due designs that have not accurately accounted for any of diffraction, scatter, diffusion, angular direction, calibration, focus, collimation, curvature, uniformity, element cross-

talk, as well as a multitude of other parameters that contribute to decreased effective resolution as well as an inability to accurately converge energy with sufficient fidelity.

[0101] In an embodiment, an approach to selective energy propagation for addressing challenges associated with holographic display may include energy inhibiting elements and substantially filling waveguide apertures with near-collimated energy into an environment defined by a 4D plenoptic function.

[0102] In an embodiment, an array of energy waveguides may define a plurality of energy propagation paths for each waveguide element configured to extend through and substantially fill the waveguide element's effective aperture in unique directions defined by a prescribed 4D function to a plurality of energy locations along a seamless energy surface inhibited by one or more elements positioned to limit propagation of each energy location to only pass through a single waveguide element.

[0103] In an embodiment, multiple energy domains may be configured within a single, or between multiple energy waveguides to direct one or more sensory holographic energy propagations including visual, acoustic, tactile or other energy domains.

[0104] In an embodiment, the energy waveguides and seamless energy surface are configured to both receive and emit one or more energy domains to provide bidirectional energy propagation throughout the system.

[0105] In an embodiment, the energy waveguides are configured to propagate non-linear or non-regular distributions of energy, including non-transmitting void regions, leveraging digitally encoded, diffractive, refractive, reflective, grin, holographic, Fresnel, or the like waveguide configurations for any seamless energy surface orientation including wall, table, floor, ceiling, room, or other geometry based environments. In an additional embodiment, an energy waveguide element may be configured to produce various geometries that provide any surface profile and/or tabletop viewing allowing users to view holographic imagery from all around the energy surface in a 360-degree configuration.

[0106] In an embodiment, the energy waveguide array elements may be reflective surfaces and the arrangement of the elements may be hexagonal, square, irregular, semi-regular, curved, non-planar, spherical, cylindrical, tilted regular, tilted irregular, spatially varying and/or multi-layered.

[0107] For any component within the seamless energy surface, waveguide, or relay components may include, but not limited to, optical fiber, silicon, glass, polymer, optical relays, diffractive, holographic, refractive, or reflective elements, optical face plates, energy combiners, beam splitters, prisms, polarization elements, spatial light modulators, active pixels, liquid crystal cells, transparent displays, or any similar materials exhibiting Anderson localization or total internal reflection.

Realizing the Holodeck

Aggregation of Bidirectional Seamless Energy Surface Systems to Stimulate Human Sensory Receptors Within Holographic Environments

[0108] It is possible to construct large-scale environments of seamless energy surface systems by tiling, fusing, bonding, attaching, and/or stitching multiple seamless energy

surfaces together forming arbitrary sizes, shapes, contours or form-factors including entire rooms. Each energy surface system may comprise an assembly having a base structure, energy surface, relays, waveguide, devices, and electronics, collectively configured for bidirectional holographic energy propagation, emission, reflection, or sensing.

[0109] In an embodiment, an environment of tiled seamless energy systems are aggregated to form large seamless planar or curved walls including installations comprising up to all surfaces in a given environment, and configured as any combination of seamless, discontinuous planar, faceted, curved, cylindrical, spherical, geometric, or non-regular geometries.

[0110] In an embodiment, aggregated tiles of planar surfaces form wall-sized systems for theatrical or venue-based holographic entertainment. In an embodiment, aggregated tiles of planar surfaces cover a room with four to six walls including both ceiling and floor for cave-based holographic installations. In an embodiment, aggregated tiles of curved surfaces produce a cylindrical seamless environment for immersive holographic installations. In an embodiment, aggregated tiles of seamless spherical surfaces form a holographic dome for immersive Holodeck-based experiences.

[0111] In an embodiment, aggregates tiles of seamless curved energy waveguides provide mechanical edges following the precise pattern along the boundary of energy inhibiting elements within the energy waveguide structure to bond, align, or fuse the adjacent tiled mechanical edges of the adjacent waveguide surfaces, resulting in a modular and seamless energy waveguide system.

[0112] In a further embodiment of an aggregated tiled environment, energy is propagated bidirectionally for multiple simultaneous energy domains. In an additional embodiment, the energy surface provides the ability to both display and capture simultaneously from the same energy surface with waveguides designed such that light field data may be projected by an illumination source through the waveguide and simultaneously received through the same energy surface. In an additional embodiment, additional depth sensing and active scanning technologies may be leveraged to allow for the interaction between the energy propagation and the viewer in correct world coordinates. In an additional embodiment, the energy surface and waveguide are operable to emit, reflect or converge frequencies to induce tactile sensation or volumetric haptic feedback. In some embodiments, any combination of bidirectional energy propagation and aggregated surfaces are possible.

[0113] In an embodiment, the system comprises an energy waveguide capable of bidirectional emission and sensing of energy through the energy surface with one or more energy devices independently paired with two-or-more-path energy combiners to pair at least two energy devices to the same portion of the seamless energy surface, or one or more energy devices are secured behind the energy surface, proximate to an additional component secured to the base structure, or to a location in front and outside of the FOV of the waveguide for off-axis direct or reflective projection or sensing, and the resulting energy surface provides for bidirectional transmission of energy allowing the waveguide to converge energy, a first device to emit energy and a second device to sense energy, and where the information is processed to perform computer vision related tasks including, but not limited to, 4D plenoptic eye and retinal tracking or sensing of interference within propagated energy patterns,

depth estimation, proximity, motion tracking, image, color, or sound formation, or other energy frequency analysis. In an additional embodiment, the tracked positions actively calculate and modify positions of energy based upon the interference between the bidirectional captured data and projection information.

[0114] In some embodiments, a plurality of combinations of three energy devices comprising an ultrasonic sensor, a visible electromagnetic display, and an ultrasonic emitting device are configured together for each of three first relay surfaces propagating energy combined into a single second energy relay surface with each of the three first surfaces comprising engineered properties specific to each device's energy domain, and two engineered waveguide elements configured for ultrasonic and electromagnetic energy respectively to provide the ability to direct and converge each device's energy independently and substantially unaffected by the other waveguide elements that are configured for a separate energy domain.

[0115] In some embodiments, disclosed is a calibration procedure to enable efficient manufacturing to remove system artifacts and produce a geometric mapping of the resultant energy surface for use with encoding/decoding technologies as well as dedicated integrated systems for the conversion of data into calibrated information appropriate for energy propagation based upon the calibrated configuration files.

[0116] In some embodiments, additional energy waveguides in series and one or more energy devices may be integrated into a system to produce opaque holographic pixels.

[0117] In some embodiments, additional waveguide elements may be integrated comprising energy inhibiting elements, beam-splitters, prisms, active parallax barriers or polarization technologies in order to provide spatial and/or angular resolutions greater than the diameter of the waveguide or for other super-resolution purposes.

[0118] In some embodiments, the disclosed energy system may also be configured as a wearable bidirectional device, such as virtual reality (VR) or augmented reality (AR). In other embodiments, the energy system may include adjustment optical element(s) that cause the displayed or received energy to be focused proximate to a determined plane in space for a viewer. In some embodiments, the waveguide array may be incorporated to holographic head-mounted-display. In other embodiments, the system may include multiple optical paths to allow for the viewer to see both the energy system and a real-world environment (e.g., transparent holographic display). In these instances, the system may be presented as near field in addition to other methods.

[0119] In some embodiments, the transmission of data comprises encoding processes with selectable or variable compression ratios that receive an arbitrary dataset of information and metadata; analyze said dataset and receive or assign material properties, vectors, surface IDs, new pixel data forming a more sparse dataset, and wherein the received data may comprise: 2D, stereoscopic, multi-view, metadata, light field, holographic, geometry, vectors or vectorized metadata, and an encoder/decoder may provide the ability to convert the data in real-time or off-line comprising image processing for: 2D; 2D plus depth, metadata or other vectorized information; stereoscopic, stereoscopic plus depth, metadata or other vectorized information; multi-view; multi-view plus depth, metadata or other vectorized information;

holographic; or light field content; through depth estimation algorithms, with or without depth metadata; and an inverse ray tracing methodology appropriately maps the resulting converted data produced by inverse ray tracing from the various 2D, stereoscopic, multi-view, volumetric, light field or holographic data into real world coordinates through a characterized 4D plenoptic function. In these embodiments, the total data transmission desired may be multiple orders of magnitudes less transmitted information than the raw light field dataset.

[0120] Selective Propagation of Energy in Light Field and Holographic Waveguide Arrays

[0121] FIG. 7 illustrates a top-down perspective view of an embodiment of an energy waveguide system 100 operable to define a plurality of energy propagation paths 108. Energy waveguide system 100 comprises an array of energy waveguides 112 configured to direct energy therethrough along the plurality of energy propagation paths 108. In an embodiment, the plurality of energy propagation paths 108 extend through a plurality of energy locations 118 on a first side of the array 116 to a second side of the array 114.

[0122] Referring to FIG. 7 and FIG. 9H, in an embodiment, a first subset 290 of the plurality of energy propagation paths 108 extend through a first energy location 122. The first energy waveguide 104 is configured to direct energy along a first energy propagation path 120 of the first subset 290 of the plurality of energy propagation paths 108. The first energy propagation path 120 may be defined by a first chief ray 138 formed between the first energy location 122 and the first energy waveguide 104. The first energy propagation path 120 may comprise rays 138A and 138B, formed between the first energy location 122 and the first energy waveguide 104, which are directed by first energy waveguide 104 along energy propagation paths 120A and 120B, respectively. The first energy propagation path 120 may extend from the first energy waveguide 104 towards the second side of the array 114. In an embodiment, energy directed along the first energy propagation path 120 comprises one or more energy propagation paths between or including energy propagation paths 120A and 120B, which are directed through the first energy waveguide 104 in a direction that is substantially parallel to the angle propagated through the second side 114 by the first chief ray 138.

[0123] Embodiments may be configured such that energy directed along the first energy propagation path 120 may exit the first energy waveguide 104 in a direction that is substantially parallel to energy propagation paths 120A and 120B and to the first chief ray 138. It may be assumed that an energy propagation path extending through an energy waveguide element 112 on the second side 114 comprises a plurality of energy propagation paths of a substantially similar propagation direction.

[0124] FIG. 8 is a front view illustration of an embodiment of energy waveguide system 100. The first energy propagation path 120 may extend towards the second side 114 of the array 112 shown in FIG. 7 in a unique direction 208 extending from the first energy waveguide 104, which is determined at least by the first energy location 122. The first energy waveguide 104 may be defined by a spatial coordinate 204, and the unique direction 208 which is determined at least by first energy location 122 may be defined by an angular coordinate 206 defining the directions of the first energy propagation path 120. The spatial coordinate 204 and the angular coordinate 206 may form a four-dimensional

plenoptic coordinate set 210 which defines the unique direction 208 of the first energy propagation path 120.

[0125] In an embodiment, energy directed along the first energy propagation path 120 through the first energy waveguide 104 substantially fills a first aperture 134 of the first energy waveguide 104, and propagates along one or more energy propagation paths which lie between energy propagation paths 120A and 120B and are parallel to the direction of the first energy propagation path 120. In an embodiment, the one or more energy propagation paths that substantially fill the first aperture 134 may comprise greater than 50% of the first aperture 134 diameter.

[0126] In a preferred embodiment, energy directed along the first energy propagation path 120 through the first energy waveguide 104 which substantially fills the first aperture 134 may comprise between 50% to 80% of the first aperture 134 diameter.

[0127] Turning back to FIGS. 7 and 9A-H, in an embodiment, the energy waveguide system 100 may further comprise an energy inhibiting element 124 positioned to limit propagation of energy between the first side 116 and the second side 114 and to inhibit energy propagation between adjacent waveguides 112. In an embodiment, the energy inhibiting element is configured to inhibit energy propagation along a portion of the first subset 290 of the plurality of energy propagation paths 108 that do not extend through the first aperture 134. In an embodiment, the energy inhibiting element 124 may be located on the first side 116 between the array of energy waveguides 112 and the plurality of energy locations 118. In an embodiment, the energy inhibiting element 124 may be located on the second side 114 between the plurality of energy locations 118 and the energy propagation paths 108. In an embodiment, the energy inhibiting element 124 may be located on the first side 116 or the second side 114 orthogonal to the array of energy waveguides 112 or the plurality of energy locations 118.

[0128] In an embodiment, energy directed along the first energy propagation path 120 may converge with energy directed along a second energy propagation path 126 through a second energy waveguide 128. The first and second energy propagation paths may converge at a location 130 on the second side 114 of the array 112. In an embodiment, a third and fourth energy propagation paths 140, 141 may also converge at a location 132 on the first side 116 of the array 112. In an embodiment, a fifth and sixth energy propagation paths 142, 143 may also converge at a location 136 between the first and second sides 116, 114 of the array 112.

[0129] In an embodiment, the energy waveguide system 100 may comprise structures for directing energy such as: a structure configured to alter an angular direction of energy passing therethrough, for example a refractive, diffractive, reflective, gradient index, holographic, or other optical element; a structure comprising at least one numerical aperture; a structure configured to redirect energy off at least one internal surface; an optical relay; etc. It is to be appreciated that the waveguides 112 may include any one or combination of bidirectional energy directing structure or material, such as:

[0130] a) refraction, diffraction, or reflection;

[0131] b) single or compound multilayered elements;

[0132] c) holographic optical elements and digitally encoded optics;

[0133] d) 3D printed elements or lithographic masters or replicas;

[0134] e) Fresnel lenses, gratings, zone plates, binary optical elements;

[0135] f) retro reflective elements;

[0136] g) fiber optics, total internal reflection or Anderson Localization;

[0137] h) gradient index optics or various refractive index matching materials;

[0138] i) glass, polymer, gas, solids, liquids;

[0139] j) acoustic waveguides;

[0140] k) micro & nano scale elements; or

[0141] l) polarization, prisms or beam splitters.

[0142] In an embodiment, the energy waveguide systems propagate energy bidirectionally.

[0143] In an embodiment, the energy waveguides are configured for propagation of mechanical energy.

[0144] In an embodiment, the energy waveguides are configured for propagation of electromagnetic energy.

[0145] In an embodiment, by interlacing, layering, reflecting, combining, or otherwise provisioning the appropriate material properties within one or more structures within an energy waveguide element, and within one or more layers comprising an energy waveguide system, the energy waveguides are configured for simultaneous propagation of mechanical, electromagnetic and/or other forms of energy.

[0146] In an embodiment, the energy waveguides propagate energy with differing ratios for u and v respectively within a 4D coordinate system.

[0147] In an embodiment, the energy waveguides propagate energy with an anamorphic function. In an embodiment, the energy waveguides comprise multiple elements along the energy propagation path.

[0148] In an embodiment, the energy waveguides are directly formed from optical fiber relay polished surfaces.

[0149] In an embodiment, the energy waveguide system comprises materials exhibiting Transverse Anderson Localization.

[0150] In an embodiment, the energy waveguide system propagates hypersonic frequencies to converge tactile sensation in a volumetric space.

[0151] FIGS. 9A-H are illustrations of various embodiments of energy inhibiting element 124. For the avoidance of doubt, these embodiments are provided for exemplary purposes and in no way limiting to the scope of the combinations or implementations provided within the scope of this disclosure.

[0152] FIG. 9A illustrates an embodiment of the plurality of energy locations 118 wherein an energy inhibiting element 251 is placed adjacent to the surface of the energy locations 118 and comprises a specified refractive, diffractive, reflective, or other energy altering property. The energy inhibiting element 251 may be configured to limit the first subset of energy propagation paths 290 to a smaller range of propagation paths 253 by inhibiting propagation of energy along energy propagation paths 252. In an embodiment, the energy inhibiting element is an energy relay with a numerical aperture less than 1.

[0153] FIG. 9B illustrates an embodiment of the plurality of energy locations 118 wherein an energy inhibiting structure 254 is placed orthogonal between regions of energy locations 118, and wherein the energy inhibiting structure 254 exhibits an absorptive property, and wherein the inhibiting energy structure 254 has a defined height along an

energy propagation path 256 such that certain energy propagation paths 255 are inhibited. In an embodiment, the energy inhibiting structure 254 is hexagonal in shape. In an embodiment, the energy inhibiting structure 254 is round in shape. In an embodiment, the energy inhibiting structure 254 is non-uniform in shape or size along any orientation of the propagation path. In an embodiment, the energy inhibiting structure 254 is embedded within another structure with additional properties.

[0154] FIG. 9C illustrates the plurality of energy locations 118, wherein a first energy inhibiting structure 257 is configured to substantially orient energy 259 propagating there-through into a first state. A second energy inhibiting structure 258 is configured to allow energy 259, which is substantially oriented in the first state, to propagate there-through, and to limit propagation of energy 260 oriented substantially dissimilarly to the first state. In an embodiment, the energy inhibiting element 257, 258 is an energy polarizing element pair. In an embodiment, the energy inhibiting element 257, 258 is an energy wave band pass element pair. In an embodiment, the energy inhibiting element 257, 258 is a diffractive waveguide pair.

[0155] FIG. 9D illustrates an embodiment of the plurality of energy locations 118, wherein an energy inhibiting element 261 is structured to alter energy propagation paths 263 to a certain extent depending upon which of the plurality of energy locations 118 the energy propagation paths 263 extends through. Energy inhibiting element 261 may alter energy propagation paths 263 in a uniform or non-uniform way along energy propagation paths 263 such that certain energy propagation paths 262 are inhibited. An energy inhibiting structure 254 is placed orthogonal between regions of energy locations 118, and wherein the energy inhibiting structure 254 exhibits an absorptive property, and wherein the inhibiting energy structure 254 has a defined height along an energy propagation path 263 such that certain energy propagation paths 262 are inhibited. In an embodiment, an inhibiting element 261 is a field lens. In an embodiment, an inhibiting element 261 is a diffractive waveguide. In an embodiment, an inhibiting element 261 is a curved waveguide surface.

[0156] FIG. 9E illustrates an embodiment of the plurality of energy locations 118, wherein an energy inhibiting element 264 provides an absorptive property to limit the propagation of energy 266 while allowing other propagation paths 267 to pass.

[0157] FIG. 9F illustrates an embodiment of the plurality of energy locations 118, and the plurality of energy waveguides 112, wherein a first energy inhibiting structure 268 is configured to substantially orient energy 270 propagating there-through into a first state. A second energy inhibiting structure 271 is configured to allow energy 270, which is substantially oriented in the first state, to propagate there-through, and to limit propagation of energy 269 oriented substantially dissimilarly to the first state. In order to further control energy propagation through a system, exemplified by the stray energy propagation 272, energy inhibiting structures 268, 271 may require a compound energy inhibiting element to ensure energy propagation maintains accurate propagation paths.

[0158] FIG. 9G illustrates an embodiment of the plurality of energy locations 118, and wherein an energy inhibiting element 276 provides an absorptive property to limit the propagation of energy along energy propagation path 278

while allowing other energy along energy propagation path 277 to pass through a pair of energy waveguides 112 for an effective aperture 284 within the array of waveguides 112. In an embodiment, energy inhibiting element 276 comprises black chrome. In an embodiment, energy inhibiting element 276 comprises an absorptive material. In an embodiment, energy inhibiting element 276 comprises a transparent pixel array. In an embodiment, energy inhibiting element 276 comprises an anodized material.

[0159] FIG. 9H illustrates an embodiment comprising a plurality of energy locations 118, and a plurality of energy waveguides 112, wherein a first energy inhibiting structure 251 is placed adjacent to the surface of the energy locations 118 and comprises a specified refractive, diffractive, reflective, or other energy altering property. The energy inhibiting structure 251 may be configured to limit the first subset of energy propagation paths 290 to a smaller range of propagation paths 275 by inhibiting propagation of energy along energy propagation paths 274. A second energy inhibiting structure 261 is structured to alter energy propagation paths 275 to a certain extent depending upon which of the plurality of energy locations 118 the energy propagation paths 275 extends through. Energy inhibiting structure 261 may alter energy propagation paths 275 in a uniform or non-uniform way such that certain energy propagation paths 274 are inhibited. A third energy inhibiting structure 254 is placed orthogonal between regions of energy locations 118. The energy inhibiting structure 254 exhibits an absorptive property, and has a defined height along an energy propagation path 275 such that certain energy propagation paths 274 are inhibited. An energy inhibiting element 276 provides an absorptive property to limit the propagation of energy 280 while allowing energy 281 to pass through. A compound system of similar or dissimilar waveguide elements 112 are positioned to substantially fill an effective waveguide element aperture 285 with energy from the plurality of energy locations 118 and to alter the propagation path 273 of energy as defined by a particular system.

[0160] In an embodiment, the energy inhibiting element 124 may comprise a structure for attenuating or modifying energy propagation paths. In an embodiment, the energy inhibiting element 124 may include one or more energy absorbing elements or walls positioned within the system to limit propagation of energy to or from the waveguides 112. In an embodiment, the energy inhibiting element 124 may include a specified numerical aperture, positioned within the system 100 to limit the angular distribution of energy to and from waveguide 112.

[0161] In an embodiment, the energy inhibiting element 124 may include one or more energy blocking walls, structures, metal, plastic, glass, epoxy, pigment, liquid, display technologies or other absorptive or structural material, with a determined thickness between a plane of energy locations 122 and a waveguide array plane with voids or structures that are up to the pitch of a waveguide aperture diameter.

[0162] In an embodiment, the energy inhibiting structure 124 is located proximate the first energy location 122 and comprises an optical relay faceplate adjacent to the first energy location 122. In an embodiment, the energy inhibiting element 124 may include an optical relay faceplate comprising one or more spatially consistent or variable numerical apertures, wherein the numerical aperture value meaningfully limits the angular distribution of energy to and from the waveguide 112. For example, an embodiment of

the numerical aperture may be designed to provide an angular distribution that is at or near two times the field of view formed between the energy location and perpendicular to the center of the effective waveguide element size, entrance pupil, aperture, or other physical parameter for energy propagation, to provide off-axis fill factor for the specified waveguide aperture 134.

[0163] In an embodiment, the energy inhibiting element 124 may include a binary, gradient index, Fresnel, holographic optical element, zone plate or other diffractive optical element that alters the path of energy waves through the system to decrease scatter, diffusion, stray light, or chromatic aberration. In an embodiment, the energy inhibiting element 124 may include a positive or negative optical element at or around the location wherein the energy propagation path is altered to further increase the fill factor of the waveguide aperture 134 or decrease stray light. In an embodiment, the energy inhibiting element 124 may include an active or passive polarized element combined with a second active or passive polarized element designed to provide spatial or time multiplexed attenuation of defined regions of the energy location 122, waveguide aperture 134, or other regions. In an embodiment, the energy inhibiting element 124 may include an active or passive aperture stop barrier designed to provide spatial or time multiplexed attenuation of defined regions of the energy location 122, waveguide aperture 134, or other regions. In an embodiment, the energy inhibiting element 124 may include any one the following or any combination thereof:

- [0164] a) physical energy baffle structures;
- [0165] b) volumetric, tapered or faceted mechanical structures;
- [0166] c) aperture stops or masks;
- [0167] d) optical relays and controlled numerical apertures;
- [0168] e) refraction, diffraction, or reflection;
- [0169] f) retro reflective elements;
- [0170] g) single or compound multilayered elements;
- [0171] h) holographic optical elements and digitally encoded optics;
- [0172] i) 3D printed elements or lithographic masters or replicas;
- [0173] j) Fresnel lenses, gratings, zone plates, binary optical elements;
- [0174] k) fiber optics, total internal reflection or Anderson localization;
- [0175] l) gradient index optics or various refractive index matching materials;
- [0176] m) glass, polymer, gas, solids, liquids;
- [0177] n) milli, micro & nano scale elements; and
- [0178] o) polarization, prisms or beam splitters

[0179] In an embodiment, the energy inhibiting structure 124 may be constructed to include hexagonally packed energy blocking baffles constructed to form voids that are tapered along the Z axis, decreasing in void size as the aperture stop location for the waveguide system is reached. In another embodiment, the energy inhibiting structure 124 may be constructed to include hexagonally packed energy blocking baffles bonded to an optical relay face plate. In another embodiment, the energy inhibiting structure 124 may be constructed to include hexagonally packed energy blocking baffles filled with a prescribed refractive index to further alter the path of energy wave projection to and from the energy waveguide array. In another embodiment, a

diffractive or refractive element may be placed, attached or bonded to the energy blocking baffle with a defined waveguide prescription to further alter the path of energy projection to and from the waveguide elements 112. In another example, the energy inhibiting structure 124 may be formed into a single mechanical assembly, and the energy waveguide array 112 may be placed, attached or bonded to the assembled energy inhibiting element 124. It is to be appreciated that other implementations may be leveraged to enable other energy waveguide configurations or super-resolution considerations.

[0180] In an embodiment, the energy inhibiting structure 124 may be located proximate the first energy location 122 and generally extend towards the first energy waveguide 104. In an embodiment, the energy inhibiting structure 124 may be located proximate the first energy waveguide 104 and generally extend towards the first energy location 122.

[0181] In an embodiment, the energy inhibiting elements are configured for inhibiting electromagnetic energy.

[0182] In an embodiment, the energy inhibiting elements are configured for inhibiting mechanical energy.

[0183] In an embodiment, by interlacing, layering, reflecting, combining, or otherwise provisioning the appropriate material properties within one or more structures within an energy inhibiting element, and within one or more layers comprising an energy waveguide system, the energy inhibiting elements are configured for simultaneous attenuation of mechanical, electromagnetic and/or other forms of energy.

[0184] In an embodiment, an array of energy waveguides may be arranged to form a planar surface, or a curved surface of a desirable shape. FIG. 13 is an illustration of an embodiment 1100 featuring an array of energy waveguides 1102 arranged in a curved configuration.

[0185] Embodiments of the present disclosure may be configured to direct energy of any wavelength belonging to the electromagnetic spectrum, including visible light, ultraviolet, infrared, x-ray, etc. The present disclosure may also be configured to direct other forms of energy such as acoustic sound vibrations and tactile pressure waves.

[0186] FIG. 10 is an illustration of an additional embodiment of an energy waveguide system 300. The energy waveguide system 300 may define a plurality of energy propagation paths 304, and may comprise a reflector element 314 comprising a first reflector 306 located on a first side 310 of the reflector element 314, the first reflector 306 comprising one or more aperture stops 316 formed there-through, and a second reflector 308 located on a second side 312 of the reflector element 314, the second reflector 308 comprising one or more aperture stops 318 formed there-through. The first and second reflectors 306, 308 are configured to direct energy along a plurality of energy propagation paths 304 extending through the aperture stops of the first and second reflectors 316, 318 and a plurality of energy locations 320 on the first side 310 of the reflector element 314. A first subset 322 of the plurality of energy propagation paths 304 extend through a first energy location 324. The reflector element 314 is configured to direct energy along a first energy propagation path 326 of the first subset 322 of the plurality of energy propagation paths 304.

[0187] In an embodiment, the first energy propagation path 326 may be defined by a first chief ray 338 formed between the first energy location 324 and a first aperture stop 328 of the first reflector 306. The first energy propagation path 326 may extend from a first aperture stop 330 of the

second reflector 308 towards the second side 312 of the reflector element 314 in a unique direction extending from the first aperture stop 330 of the second reflector 308, which is determined at least by the first energy location 324.

[0188] In an embodiment, energy directed along the first energy propagation path 326 substantially fills the first aperture stop 328 of the first reflector 306 and the first aperture stop 330 of the second reflector 308.

[0189] In an embodiment, an energy inhibiting element 332 may be positioned to limit propagation of energy along a portion of the first subset 322 of the plurality of energy propagation paths 304 that do not extend through the first aperture stop 328 of the first reflector 306.

[0190] In an embodiment in which the energy is light and the energy waveguide is operable to direct said light, with a perfect parabolic structure, any ray that passes through, or from, the focus of the first reflector will reflect parallel to the optical axis, reflect off of the second reflector, and then relay at the same angle in the inverse orientation.

[0191] In an embodiment, the first reflector and second reflector have differing focal lengths, in order to produce varied magnification of the energy information and/or to alter angular field of view coverage as a viewer from above the surface of the second reflector would view the reflected information. The aperture stops may be of differing sizes for varied design purposes in collaboration with the varied focal lengths.

[0192] An additional embodiment is provided where both reflective surfaces are conical, faceted, curved in a non-linear shape or otherwise. The design of this curvature is critical to ensuring that the display information and the viewed information may have a non-linear relationship to change or simplify signal processing.

[0193] In an embodiment, the energy waveguides comprise flexible reflective surfaces capable of altering the reflective surface profile dynamically to change the propagation path of energy through the energy waveguide system.

[0194] In an embodiment, additional waveguides, including but not limited to reflective or optical elements, birefringent materials, liquid lenses, refractive, diffractive, holographic, or the like, may be located anywhere within the energy propagation path. With this approach, one such embodiment provides a design such that when viewed, the view angles are at significantly different position than the aperture stop and focal length would have provided otherwise. FIG. 11 demonstrates one such application of this approach.

[0195] FIG. 11 is an illustration of an embodiment of an energy waveguide system 700. Energy waveguide system 700 comprises first and second reflectors 702 and 704, respectively. Positioned at the focus of the second reflector 702 are additional optical elements 706 and an energy inhibitor 707 perpendicular to the energy location 708. The additional optical elements are designed to affect energy propagation paths of energy propagating through energy waveguide system 700. Additional waveguide elements may be included within the energy waveguide system 700, or additional energy waveguide systems may be placed into the energy propagation path.

[0196] In an embodiment, the array of energy waveguide elements may include:

[0197] a) A hexagonal packing of the array of energy waveguides;

[0198] b) A square packing of the array of energy waveguides;

[0199] c) An irregular or semi-regular packing of the array of energy waveguides;

[0200] d) Curved or Non-planar array of energy waveguides;

[0201] e) Spherical array of energy waveguides;

[0202] f) Cylindrical array of energy waveguides;

[0203] g) Tilted regular array of energy waveguides;

[0204] h) Tilted irregular array of energy waveguides;

[0205] i) Spatially varying array of energy waveguides;

[0206] j) Multi-layered array of energy waveguides;

[0207] FIG. 12 highlights the differences between square packing 901, hex packing 902 and irregular packing 903 of an array of energy waveguide elements.

[0208] Energy waveguides may be fabricated on a glass or plastic substrate to specifically include optical relay elements if desirable and may be designed with glass or plastic optical elements to specifically include optical relays as well as desired. Furthermore, the energy waveguide may be faceted for designs that provide multiple propagation paths or other column/row or checkerboard orientations, specifically considering but not limited to multiple propagation paths separated by beam-splitters or prisms, or tiled for waveguide configurations that allow for tiling, or a singular monolithic plate, or tiled in a curved arrangement (e.g. faceted cylinder or spherical with geometry alterations to the tiles to mate accordingly), curved surfaces to include but not limited to spherical and cylindrical or any other arbitrary geometry as required for a specific application.

[0209] In an embodiment where the array of energy waveguides comprises a curved configuration, the curved waveguide may be produced via heat treatments or by direct fabrication onto curved surfaces to include optical relay elements.

[0210] In an embodiment, the array of energy waveguides may abut other waveguides and may cover entire walls and/or ceilings and or rooms depending on specific application. The waveguides may be designed explicitly for substrate up or substrate down mounting. The waveguide may be designed to mate directly to an energy surface or be offset with an air gap or other offset medium. The waveguide may include an alignment apparatus to provide the ability to focus the plane actively or passively either as a permanent fixture or a tooling element. The purposes of the geometries described is to help optimize the angle of view defined by the normal of the waveguide element and the represented imagery. For a very large energy surface planar surface, the majority of the angular samples at the left and right-most of the surface are mainly outside of the viewing volume for an environment. For that same energy surface, with a curved contour and a curved waveguide, the ability to use more of these propagating rays to form the converging volume is increased significantly. This is however at the expense of usable information when off-axis. The application specific nature of the design generally dictates which of the proposed designs will be implemented. Furthermore, a waveguide may be designed with regular, graduated, or regional element structures that are fabricated with an additional waveguide element to tilt the element towards a predetermined waveguide axis.

[0211] In embodiments where the energy waveguides are lenses, the embodiments may include both convex and concave lenslets, and may include the fabrication of the

lenses directly onto an optical relay surface. This may involve destructive or additive lenslet fabrication processes to include removal of material to form or stamp and lenslet profile, or the direct replica fabricated directly to this surface.

[0212] An embodiment may include a multiple layered waveguide design that provides additional energy propagation optimizations and angular control. All of the above embodiments may be combined together independently or in conjunction with this approach. In an embodiment, a multiple layered design may be envisioned with tilted waveguide structures on a first waveguide element and a regionally varying structure for a second waveguide element.

[0213] An embodiment includes the design and fabrication of a per element or per region liquid lens waveguide joined together as a single waveguide. An additional design of this approach includes a single birefringent or liquid lens waveguide electrical cell that can modify an entire waveguide array simultaneously. This design provides the ability to dynamically control the effective waveguide parameters of the system without redesigning the waveguide.

[0214] In an embodiment configured to direct light, with any combination of the disclosures provided herein, it is possible to generate a wall mounted 2D, light field or holographic display. The wall mounted configuration is designed such that a viewer is looking at an image that may float in front, at or behind of the designed display surface. With this approach, the angular distribution of rays may be uniform, or provided with increased density at any particular placement in space depending on specific display requirements. In this fashion, it is possible to configure the waveguides to alter angular distribution as a function of surface profile. For example, for a given distance perpendicular to the display surface and a planar waveguide array, an optically perfect waveguide would provide increased density at the perpendicular center of the display with a gradual increase in ray separation distance along a given perpendicular distance to the display. Conversely, if viewing the rays radially about the display where a viewer maintains a distance between the eyes and the center point of the display, the viewed rays would maintain consistent density across the entire field of view. Depending on the anticipated viewing conditions, the properties of each element may be optimized by altering the waveguide functions to produce any potential distribution of rays to optimize the viewing experience for any such environment.

[0215] FIG. 14 is an illustration of an embodiment 1200 which highlights how a single waveguide element function 1202 may produce identical distribution of energy 1204 across a radial viewing environment 1206, whereas the same waveguide element function 1202 when propagated at a distance 1208 that is constant and parallel to the waveguide surface 1210 will appear to exhibit increased density at the waveguide element center 1212 of the waveguide surface and decreased density further from the center 1212 of the waveguide surface.

[0216] FIG. 15 is an illustration of an embodiment 1300 which illustrates configuring the waveguide element functions 1302 to exhibit uniform density at a constant distance 1304 parallel to the waveguide surface 1306 that simultaneously produces apparent lower density at the center 1310 of the waveguide surface 1306 when measured about a radius 1308 about the center of the waveguide surface 1306.

[0217] The ability to generate a waveguide function that varies sampling frequency over field distance is a characteristic of various waveguide distortions and known in the art. Traditionally, the inclusion of distortions are undesirable in a waveguide function, however, for the purposes of waveguide element design, these are all characteristics that are claimed as benefits to the ability to further control and distribute the propagation of energy depending on the specific viewing volume required. It may require the addition of multiple functions or layers or a gradient of functions across the entirety of the waveguide array depending on the viewing volume requirements.

[0218] In an embodiment, the functions are further optimized by curved surfaces of the energy surface and/or the waveguide array. The variation of the normal of the chief ray angle in relation to the energy surface itself may further increase efficiency and require a different function than a planar surface, although the gradient, variation and/or optimization of the waveguide function still applies.

[0219] Further, leveraging the resultant optimized waveguide array in consideration of waveguide stitching methodologies, it is possible to further increase the effective size of the waveguide by tiling each of the waveguides and systems to produce any size or form-factor desired. It is important to note that the waveguide array may exhibit a seam artifact unlike the energy surface by virtue of reflections produced between any two separate substrates, the apparent contrast differential at the mechanical seam, or due to any form of non-square grid packing schema. To counteract this effect, either a larger singular waveguide may be produced, refractive matching materials may be leveraged between the edges of any two surfaces, or regular waveguide grid structures may be employed to ensure that no elements are split between two waveguide surfaces, and/or precision cutting between energy inhibiting elements and seaming along a non-square waveguide grid structure may be leveraged.

[0220] With this approach, it is possible to produce room scale 2D, light field and/or holographic displays. These displays may be seamless across large planar or curved walls, may be produced to cover all walls in a cubic fashion, or may be produced in a curved configuration where either a cylindrical-type shape, or a spherical-type shape is formed to increase view angle efficiency of the overall system.

[0221] Alternatively, it is possible to design a waveguide function that warps the propagated energy to virtually eliminate the region that is not desired in the required angle of view resulting in a non-uniform distribution of energy propagation. To accomplish this, one may implement a Taurus shaped optical profile, annular lens, concentric prism array, a Fresnel or diffractive function, binary, refractive, holographic, and/or any other waveguide design may allow for a larger aperture and shorter focal length (herein will be referred to as a “Fresnel lenslet”) to provide the ability to practically form a single or multi element (or multiple sheets) Fresnel waveguide array. This may or may not be combined with additional optics, including an additional waveguide array, depending on waveguide configuration.

[0222] In order to produce wide energy propagation angles (e.g. 180 degrees) a very low effective f/number (e.g. $<f/5$) is required and in order to ensure that no 4D “Disk Flipping” occurs (the ability for the ray from one waveguide element to see undesired energy locations underneath of any second waveguide element), it is further required that the focal

length be appropriately matched closely to the angle of view required. This means that in order to produce a ~ 160 degree viewing volume, an $\sim f/0.17$ lens and a nearly matched ~ 0.17 mm focal length is required.

[0223] FIG. 16 illustrates an embodiment 1400 wherein the plurality of energy waveguides comprise diffractive waveguide elements 1402, and demonstrates one proposed structure for a modified Fresnel waveguide element structure 1404 that produces an effectively extremely short focal length and low f/number while simultaneously directing rays of energy to explicitly defined locations 1406.

[0224] FIG. 17 illustrates an embodiment 1500 wherein the plurality of energy waveguides comprise elements 1502, and demonstrates how such a waveguide configuration 1506 may be used in an array to provide full density of ray propagation for the desired viewing volume 1504.

[0225] A further embodiment of the proposed modified waveguide configuration provides for a method to produce radially symmetric or spiraling rings or gradient of two or more materials along either or both of a transverse or longitudinal orientation with a refractive index separated by a predetermined amount with a per ring pitch with a diameter of X, where X may be constant or variable.

[0226] In a further embodiment, equal or non-linear distribution of all of the rays are produced with or without the modified waveguide configurations for wall-mounted and/or table-mounted waveguide structures as well as all room or environment based waveguide structures where multiple waveguides are tiled.

[0227] With a waveguide array, it is possible to produce planes of projected light that converge in space at a location that is not located at the surface of the display itself. By ray-tracing these rays, one can clearly see the geometry involved and how converging rays may appear both in-screen (away from the viewer) as well as off-screen (towards viewer) or both simultaneously. As planes move away from the viewer on planar displays with traditional waveguide array designs, the planes tend to grow with the frustum of the viewpoint and may become occluded by the physical frame of the display itself depending on the number of contributing illumination sources. By contrast, as planes move toward the viewer on planar displays with traditional waveguide array designs, the planes tend to shrink with the frustum of the viewpoint but are viewable from all angles at the specified location as long as the viewer is at an angle presenting energy to the eye and the virtual plane does not move beyond the angle created between the viewer and the far edge of the active display area.

[0228] In one embodiment, the viewed 2D image or images are presented off of the screen.

[0229] In another embodiment, the viewed 2D image or images are presented in screen.

[0230] In another embodiment, the viewed 2D image or images are presented simultaneously both in and/or off screen.

[0231] In another embodiment, the viewed 2D image or images are presented in combination with other volumetric elements or presented as text for other graphic design or interactive reasons.

[0232] In another embodiment, the viewed 2D image or images are presented with higher effective 2D resolution than the physical number of X and Y waveguide elements

would otherwise suggest due to the ability for rays to converge with higher density in space than physical elements.

[0233] The novelty of this approach is that it is entirely possible to manufacture a holographic display that produces both volumetric imaging capabilities, as well as extremely high resolution 2D imagery such that there is no further mechanical or electronic apparatus or alterations necessary to the waveguides in the display to move seamlessly between flat and volumetric imagery or produce other interesting effects.

[0234] With this property, it is possible to programmatically isolate certain illumination sources to present to a viewer that is only visible at explicit angles to the display.

[0235] In one embodiment, a single pixel or group of pixels are illuminated under each waveguide element at an angle that triangulates to the viewer's eye and presents an image that is only viewable from that viewer's position in space.

[0236] In another embodiment, a second illumination source or group of illumination sources are presented simultaneously to triangulate to a position that is only viewable by a second viewer and contains an image that may be the same or different than the first image presented to the first viewer. For the avoidance of doubt, this may be X addressable viewpoints where X represents the number of individually addressable viewpoints which may be one or more.

[0237] In another embodiment, these images are presented with eye, retinal, object or the like tracking leveraging sensors and algorithms known in the art, to dynamically vary the illuminated pixel location to present imagery dynamically to a triangulated location between the viewer and the pixels under each waveguide element. This may be applied to one or more viewers. The tracking may be performed as a 2D process or as a 3D/stereoscopic process, or leveraging other depth sensing technologies known in the art.

[0238] In one embodiment, the first region and second region are both parabolic in profile, with the first region focus located at the apex of the second region and the second region focus located at the apex of the first region and the display surface located at an opening located at the apex of the second region and an opening equivalent to the diameter of the display surface presented to the apex of the second region located at the apex of the first region. With this approach, the display surface image will appear to float above a surface without any physical surfaces as the viewed rays that pass through the focus of the second region from an off-axis viewpoint will reflect off of the second region surface and parallel off of the first surface and then at the same angle from the viewed position in the inverse orientation from the first region to the display surface.

[0239] In an embodiment, a dual parabolic relay system that includes two reflective regions each with a focus located at the apex of the alternate reflector, the display surface located at the apex of the second region, and an opening equivalent to the diameter of the presented display surface located at the first region producing a virtual image of the display surface. In the event that a waveguide array, holographic or light field display are leveraged, the viewed imagery will retain the nature of the holographic data as well as appearing to float in space without a physical display surface.

[0240] In another embodiment, the focus location of region two is differing to produce magnification or minifi-

cation. In a second embodiment, the regions have matched focal lengths and are offset by a distance greater than the focal length in order to produce a virtual image with increased magnification.

[0241] In another embodiment, the parabolic profiles are manufactured to accommodate a specific shape that results in differing viewed positions from the display to accommodate various display surface geometries or other required viewing angle or condition.

[0242] In another embodiment, the regions contain multiple facets in order to independently propagate rays of light by facet region rather than as a singular surface.

[0243] In another embodiment, the reflective surface are formed of energy relays such that the CRA of the energy surface exceeds the view angle possible from the curve applied to one or more surface(s) wherein the first surface that would have otherwise been a reflective surface has a certain geometric profile and the second surface at the alternate end of the waveguide element has a certain geometric profile, and cumulatively they have a CRA that reflects energy from a viewer's position and the addition of energy surface panels at the second surface may be implemented thereby providing energy information that is not viewable from the viewer's direct position but may provide energy information indirectly through one or more reflective surfaces and the associated calibration process required to compute the reflected imaging data in relation to the ultimately viewed data.

[0244] While various embodiments in accordance with the principles disclosed herein have been described above, it should be understood that they have been presented by way of example only, and are not limiting. Thus, the breadth and scope of the invention(s) should not be limited by any of the above-described exemplary embodiments, but should be defined only in accordance with the claims and their equivalents issuing from this disclosure. Furthermore, the above advantages and features are provided in described embodiments, but shall not limit the application of such issued claims to processes and structures accomplishing any or all of the above advantages.

[0245] It will be understood that the principal features of this disclosure can be employed in various embodiments without departing from the scope of the disclosure. Those skilled in the art will recognize, or be able to ascertain using no more than routine experimentation, numerous equivalents to the specific procedures described herein. Such equivalents are considered to be within the scope of this disclosure and are covered by the claims.

[0246] Additionally, the section headings herein are provided for consistency with the suggestions under 37 CFR 1.77 or otherwise to provide organizational cues. These headings shall not limit or characterize the invention(s) set out in any claims that may issue from this disclosure. Specifically, and by way of example, although the headings refer to a "Field of Invention," such claims should not be limited by the language under this heading to describe the so-called technical field. Further, a description of technology in the "Background of the Invention" section is not to be construed as an admission that technology is prior art to any invention(s) in this disclosure. Neither is the "Summary" to be considered a characterization of the invention(s) set forth in issued claims. Furthermore, any reference in this disclosure to "invention" in the singular should not be used to argue that there is only a single point of novelty in this

disclosure. Multiple inventions may be set forth according to the limitations of the multiple claims issuing from this disclosure, and such claims accordingly define the invention (s), and their equivalents, that are protected thereby. In all instances, the scope of such claims shall be considered on their own merits in light of this disclosure, but should not be constrained by the headings set forth herein.

[0247] The use of the word “a” or “an” when used in conjunction with the term “comprising” in the claims and/or the specification may mean “one,” but it is also consistent with the meaning of “one or more,” “at least one,” and “one or more than one.” The use of the term “or” in the claims is used to mean “and/or” unless explicitly indicated to refer to alternatives only or the alternatives are mutually exclusive, although the disclosure supports a definition that refers to only alternatives and “and/or.” Throughout this application, the term “about” is used to indicate that a value includes the inherent variation of error for the device, the method being employed to determine the value, or the variation that exists among the study subjects. In general, but subject to the preceding discussion, a numerical value herein that is modified by a word of approximation such as “about” may vary from the stated value by at least $\pm 1, 2, 3, 4, 5, 6, 7, 10, 12$ or 15%.

[0248] As used in this specification and claim(s), the words “comprising” (and any form of comprising, such as “comprise” and “comprises”), “having” (and any form of having, such as “have” and “has”), “including” (and any form of including, such as “includes” and “include”) or “containing” (and any form of containing, such as “contains” and “contain”) are inclusive or open-ended and do not exclude additional, unrecited elements or method steps.

[0249] Words of comparison, measurement, and timing such as “at the time,” “equivalent,” “during,” “complete,” and the like should be understood to mean “substantially at the time,” “substantially equivalent,” “substantially during,” “substantially complete,” etc., where “substantially” means that such comparisons, measurements, and timings are practicable to accomplish the implicitly or expressly stated desired result. Words relating to relative position of elements such as “near,” “proximate to,” and “adjacent to” shall mean sufficiently close to have a material effect upon the respective system element interactions. Other words of approximation similarly refer to a condition that when so modified is understood to not necessarily be absolute or perfect but would be considered close enough to those of ordinary skill in the art to warrant designating the condition as being present. The extent to which the description may vary will depend on how great a change can be instituted and still have one of ordinary skilled in the art recognize the modified feature as still having the required characteristics and capabilities of the unmodified feature.

[0250] The term “or combinations thereof” as used herein refers to all permutations and combinations of the listed items preceding the term. For example, A, B, C, or combinations thereof is intended to include at least one of: A, B, C, AB, AC, BC, or ABC, and if order is important in a particular context, also BA, CA, CB, CBA, BCA, ACB, BAC, or CAB. Continuing with this example, expressly included are combinations that contain repeats of one or more item or term, such as BB, AAA, AB, BBC, AAABCCCC, CBBAAA, CABABB, and so forth. The skilled artisan will understand that typically there is no limit

on the number of items or terms in any combination, unless otherwise apparent from the context.

[0251] All of the compositions and/or methods disclosed and claimed herein can be made and executed without undue experimentation in light of the present disclosure. While the compositions and methods of this disclosure have been described in terms of preferred embodiments, it will be apparent to those of skill in the art that variations may be applied to the compositions and/or methods and in the steps or in the sequence of steps of the method described herein without departing from the concept, spirit and scope of the disclosure. All such similar substitutes and modifications apparent to those skilled in the art are deemed to be within the spirit, scope and concept of the disclosure as defined by the appended claims.

1. An energy waveguide system for defining a plurality of energy propagation paths comprising:

an array of energy waveguides, the array comprising a first side and a second side, and being configured to direct energy therethrough along a plurality of energy propagation paths extending through a plurality of energy locations on the first side;

wherein a first subset of the plurality of energy propagation paths extend through a first energy location;

wherein a first energy waveguide is configured to direct energy along a first energy propagation path of the first subset of the plurality of energy propagation paths, the first energy propagation path defined by a first chief ray formed between the first energy location and the first energy waveguide, and further wherein the first energy propagation path extends from the first energy waveguide towards the second side of the array in a unique direction which is determined at least by the first energy location; and

wherein energy directed along the first energy propagation path through the first energy waveguide substantially fills a first aperture of the first energy waveguide; and

an energy inhibiting element positioned to limit propagation of energy along a portion of the first subset of the plurality of energy propagation paths that do not extend through the first aperture.

2. The energy waveguide system of claim 1, wherein the energy inhibiting element is located on the first side between the array of energy waveguides and the plurality of energy locations.

3. The energy waveguide system of claim 1, wherein the first energy waveguide comprises a two-dimensional spatial coordinate, and wherein the unique direction determined at least by the first energy location comprises a two-dimensional angular coordinate, whereby the 2D spatial coordinate and the 2D angular coordinate form a four-dimensional (4D) coordinate set.

4. The energy waveguide system of claim 3, wherein energy directed along the first energy propagation path comprises one or more energy rays directed through the first energy waveguide in a direction that is substantially parallel to the first chief ray.

5. The energy waveguide system of claim 1, wherein energy directed along the first energy propagation path converges with energy directed along a second energy propagation path through a second energy waveguide.

6. The energy waveguide system of claim 5, wherein the first and second energy propagation paths converge at a location on the second side of the array.

7. The energy waveguide system of claim 5, wherein the first and second energy propagation paths converge at a location on the first side of the array.

8. The energy waveguide system of claim 5, wherein the first and second energy propagation paths converge at a location between the first and second sides of the array.

9. The energy waveguide system of claim 1, wherein each energy waveguide comprises a structure for directing energy, the structure selected from a group consisting of:

- a) a structure configured to alter an angular direction of energy passing therethrough;
- b) a structure comprising at least one numerical aperture;
- c) a structure configured to redirect energy off at least one internal surface;
- d) an energy relay.

10. The energy waveguide system of claim 1, wherein the energy inhibiting element comprises a structure for attenuating or modifying energy propagation paths, the structure selected from a group consisting of:

- a) an energy blocking structure;
- b) an element configured to alter a first energy propagation path to alter a fill factor of the first aperture;
- c) a structure configured to limit an angular extent of energy proximate the first energy location.

11. The energy waveguide system of claim 10, wherein the structure configured to limit an angular extent of energy proximate the first energy location comprises an optical relay faceplate adjacent to the first energy location.

12. The energy waveguide system of claim 10, wherein the energy blocking structure comprises at least one numerical aperture.

13. The energy waveguide system of claim 10, wherein the energy blocking structure comprises a baffle structure.

14. The energy waveguide system of claim 10, wherein the energy blocking structure is positioned adjacent to the first energy waveguide and generally extends towards the first energy location.

15. The energy waveguide system of claim 10, wherein the energy blocking structure is positioned adjacent to the first energy location and generally extends towards the first energy waveguide.

16. The energy waveguide system of claim 1, wherein the array of energy waveguides are arranged to form a planar surface.

17. The energy waveguide system of claim 1, wherein the array of energy waveguides are arranged to form a curved surface.

18. The energy waveguide system of claim 1, wherein energy directed along the first energy propagation path is electromagnetic energy defined by a wavelength, the wavelength belonging to a regime selected from a group consisting of:

- a) visible light;
- b) ultraviolet;
- c) infrared;
- d) x-ray.

19. The energy waveguide system of claim 1, wherein energy directed along the first energy propagation path is mechanical energy defined by pressure waves, the waves selected from a group consisting of:

- a) tactile pressure waves;
- b) acoustic sound vibrations.

20. An energy waveguide system for defining a plurality of energy propagation paths comprising:

an array of lenslets, the array comprising a first side and a second side, and being configured to direct energy therethrough along a plurality of energy propagation paths extending through a plurality of energy locations; wherein a first subset of the plurality of energy propagation paths extend through a first energy location; wherein a first lenslet is configured to direct energy along a first energy propagation path of the first subset of the plurality of energy propagation paths, the first energy propagation path defined by a first chief ray formed between the first energy location and the first lenslet, and further wherein the first energy propagation path extends from the first energy waveguide towards the second side of the array in a unique direction which is determined at least by the first energy location; and wherein energy directed along the first energy propagation path through the first lenslet substantially fills a first aperture of the first lenslet; and

an energy inhibiting element positioned to limit propagation of energy along a portion of the first subset of the plurality of energy propagation paths that do not extend through the first aperture.

21.-32. (canceled)

* * * * *