



US 20240020934A1

(19) **United States**

(12) **Patent Application Publication**
Zohar et al.

(10) **Pub. No.: US 2024/0020934 A1**

(43) **Pub. Date: Jan. 18, 2024**

(54) **BLENDING BODY MESH INTO EXTERNAL MESH**

(71) Applicant: **Snap Inc.**, Santa Monica, CA (US)

(72) Inventors: **Matan Zohar**, Rishon LeZion (IL);
Yanli Zhao, London (GB); **Brian Fulkerson**, London (GB)

(21) Appl. No.: **18/475,813**

(22) Filed: **Sep. 27, 2023**

Related U.S. Application Data

(63) Continuation of application No. 17/447,614, filed on Sep. 14, 2021, now Pat. No. 11,798,238.

Publication Classification

(51) Int. Cl.	
<i>G06T 19/00</i>	(2006.01)
<i>G06T 7/246</i>	(2006.01)
<i>G06T 13/40</i>	(2006.01)
<i>G06T 13/80</i>	(2006.01)
<i>G06T 17/20</i>	(2006.01)
<i>G06T 19/20</i>	(2006.01)

(52) **U.S. Cl.**
CPC *G06T 19/006* (2013.01); *G06T 7/251* (2017.01); *G06T 13/40* (2013.01); *G06T 13/80* (2013.01); *G06T 17/20* (2013.01); *G06T 19/20* (2013.01); *G06T 2200/24* (2013.01); *G06T 2207/10016* (2013.01); *G06T 2219/2021* (2013.01)

(57) **ABSTRACT**

Methods and systems are disclosed for performing operations comprising: receiving a video that includes a depiction of a real-world object; generating a three-dimensional (3D) body mesh associated with the real-world object that tracks movement of the real-world object across frames of the video; obtaining an external mesh associated with an augmented reality (AR) element; automatically establishing a correspondence between a portion of the 3D body mesh associated with the real-world object and the external mesh; blending the portion of the 3D body mesh into the external mesh according to a blending parameter; and as the portion of the 3D body mesh is being blended into the external mesh, modifying the video to depict a portion of the real-world object being changed into the AR element.

600 →

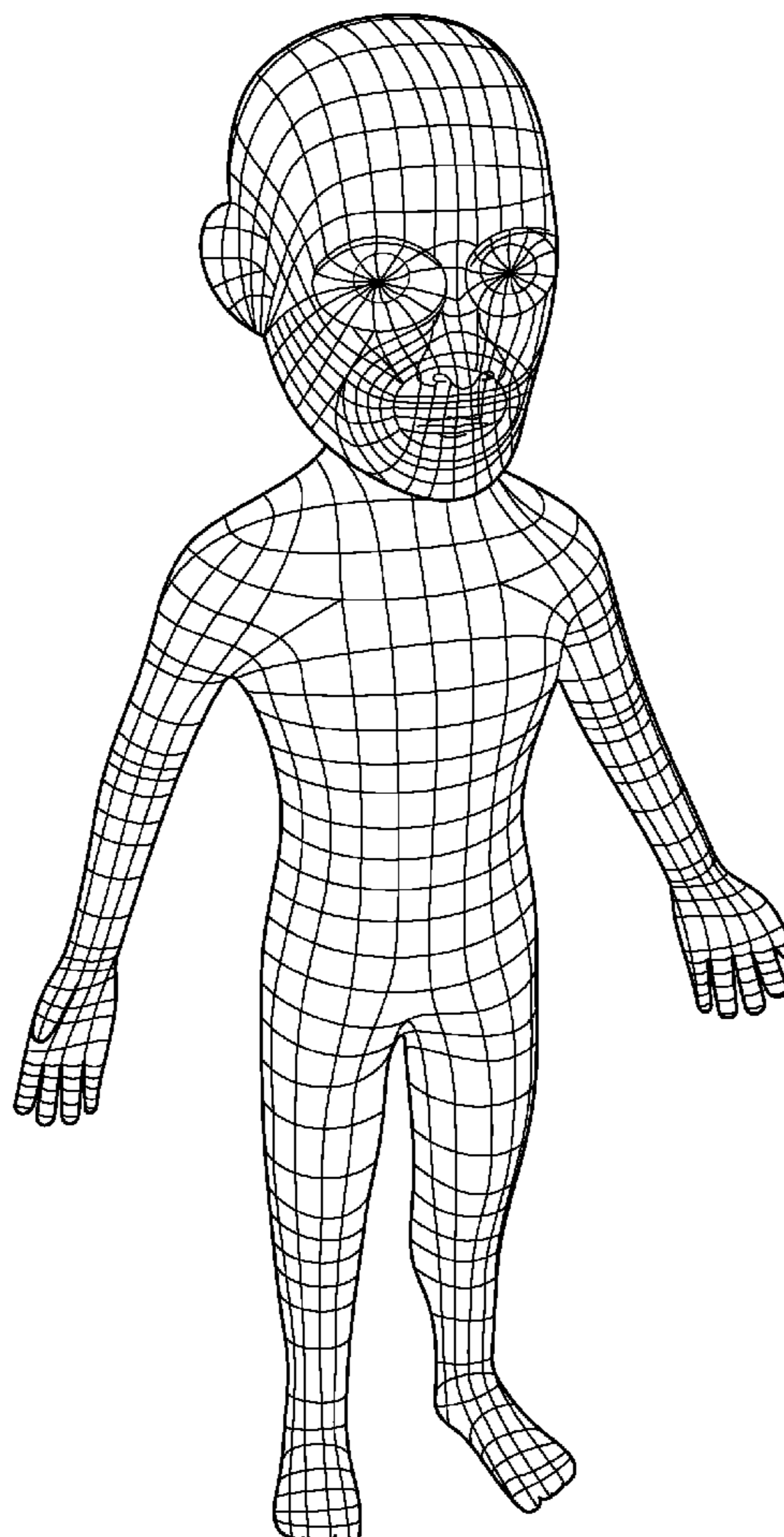

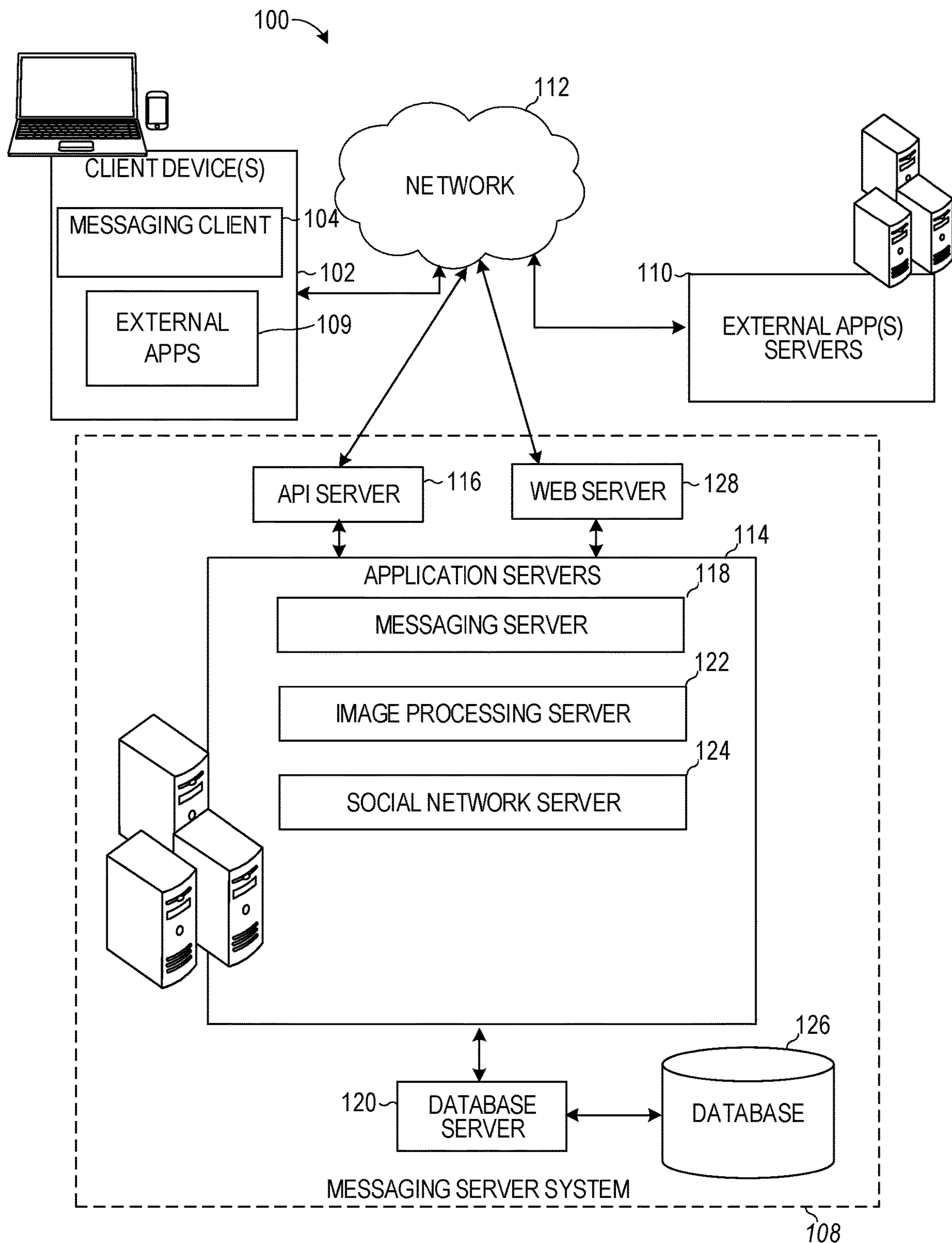

FIG. 1

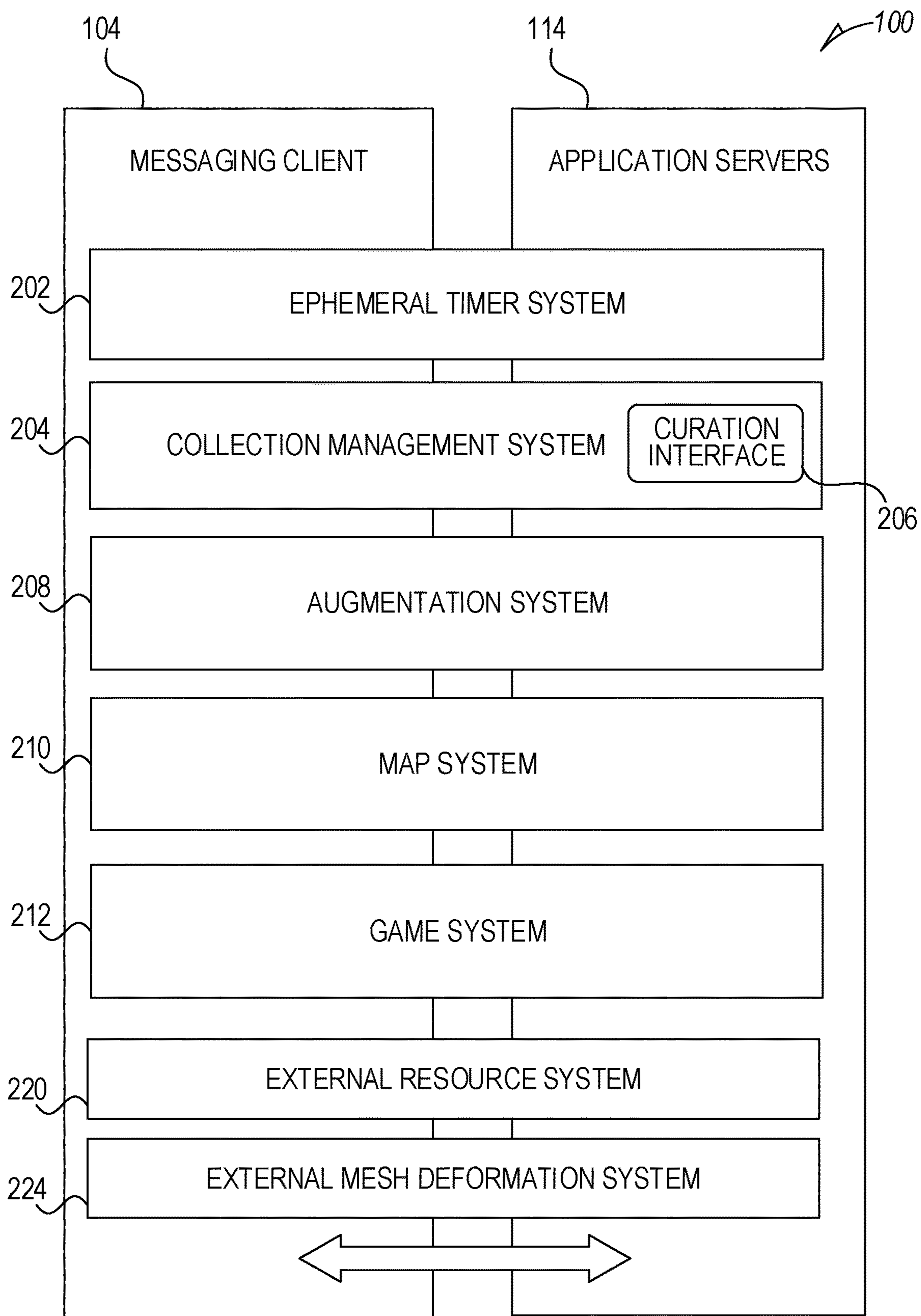

FIG. 2

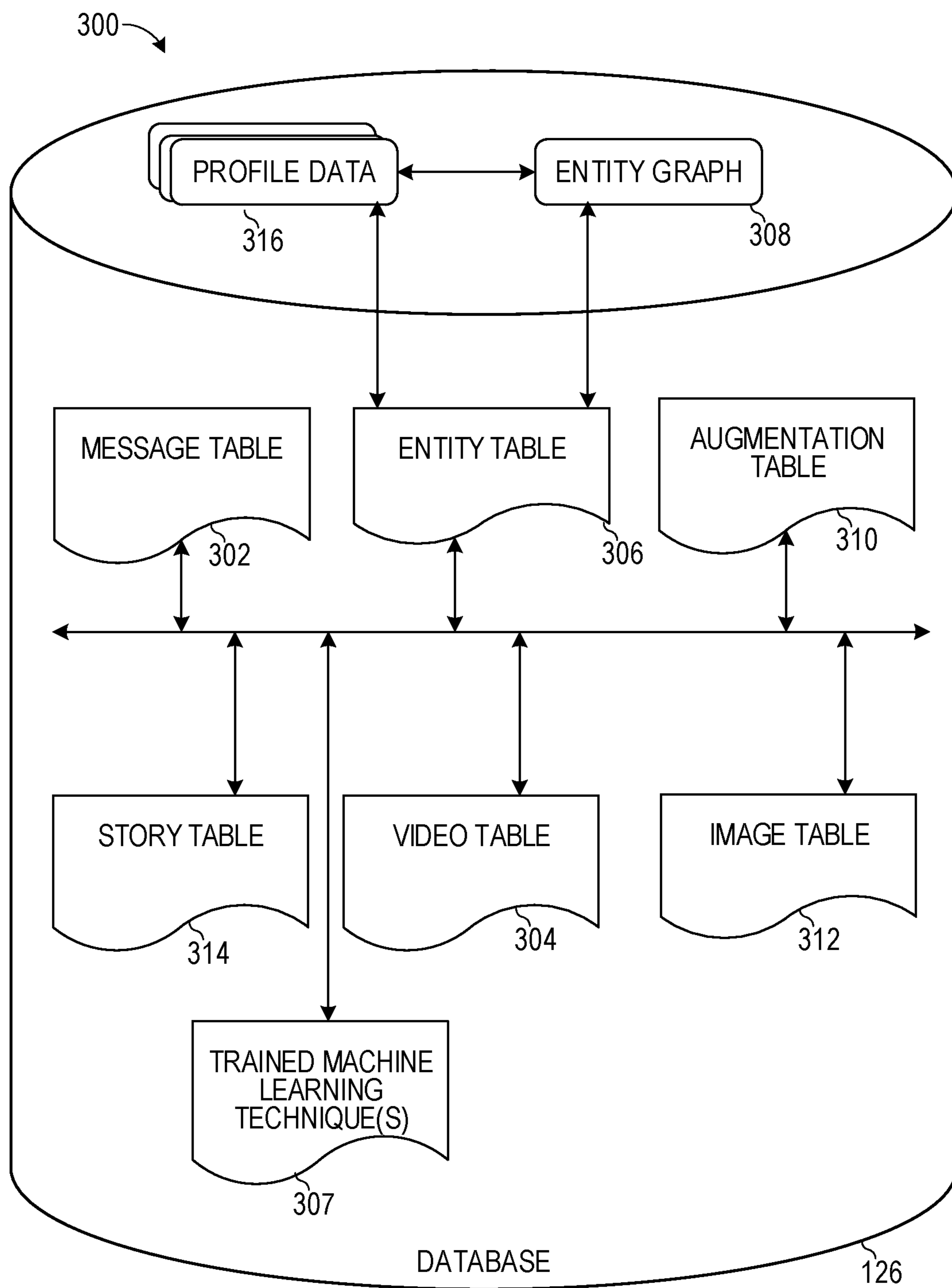

FIG. 3

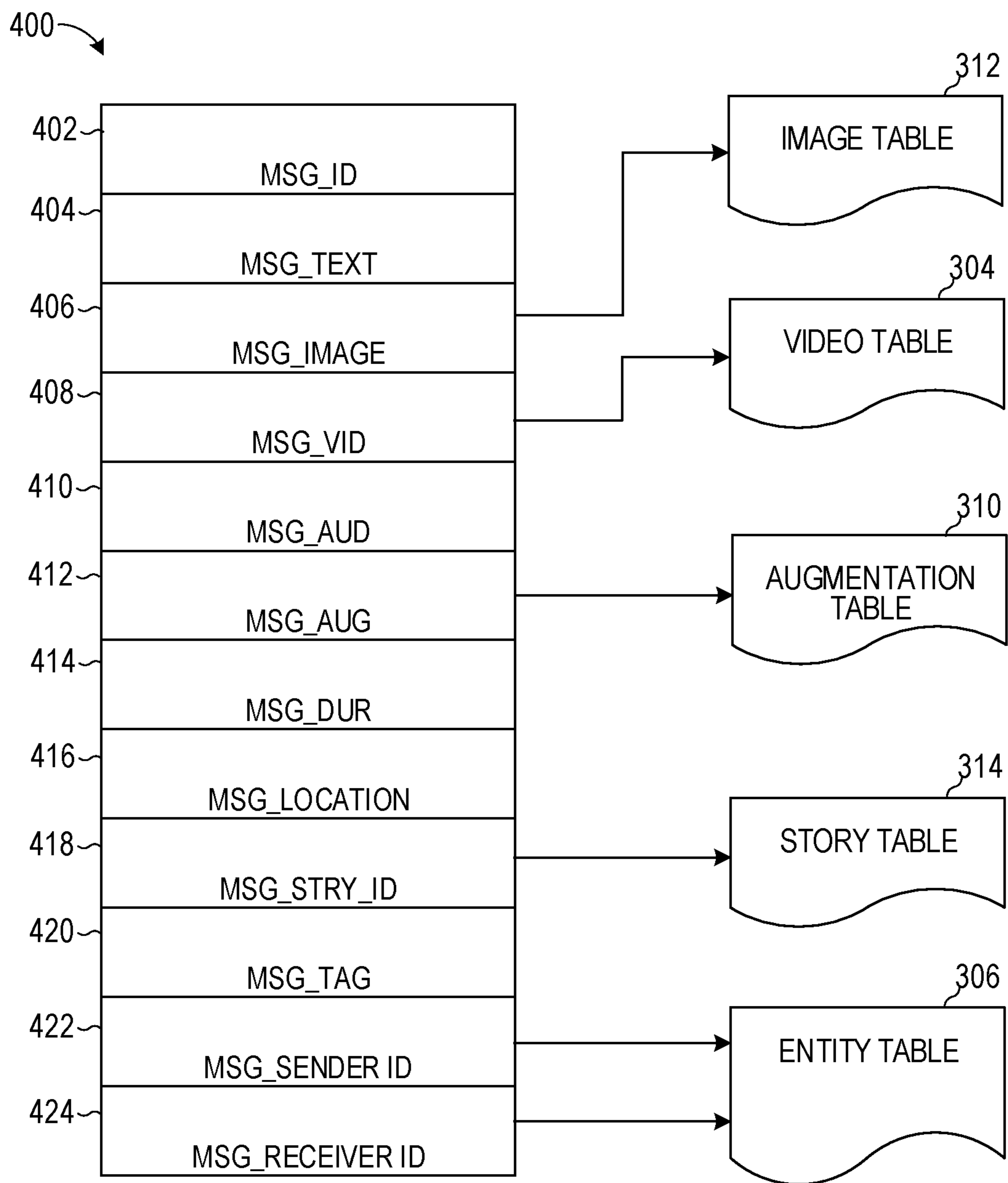

FIG. 4

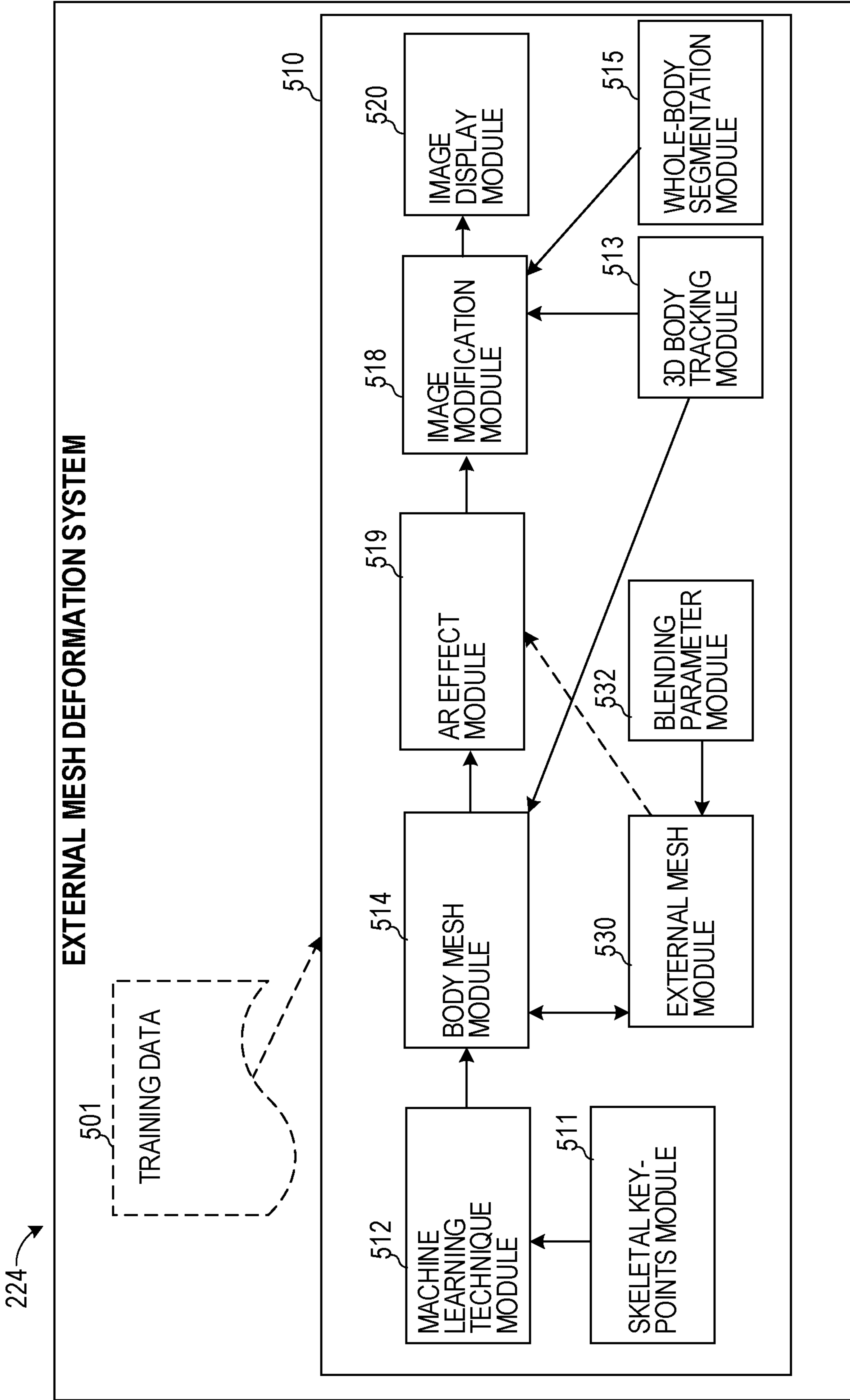

FIG. 5

600 →

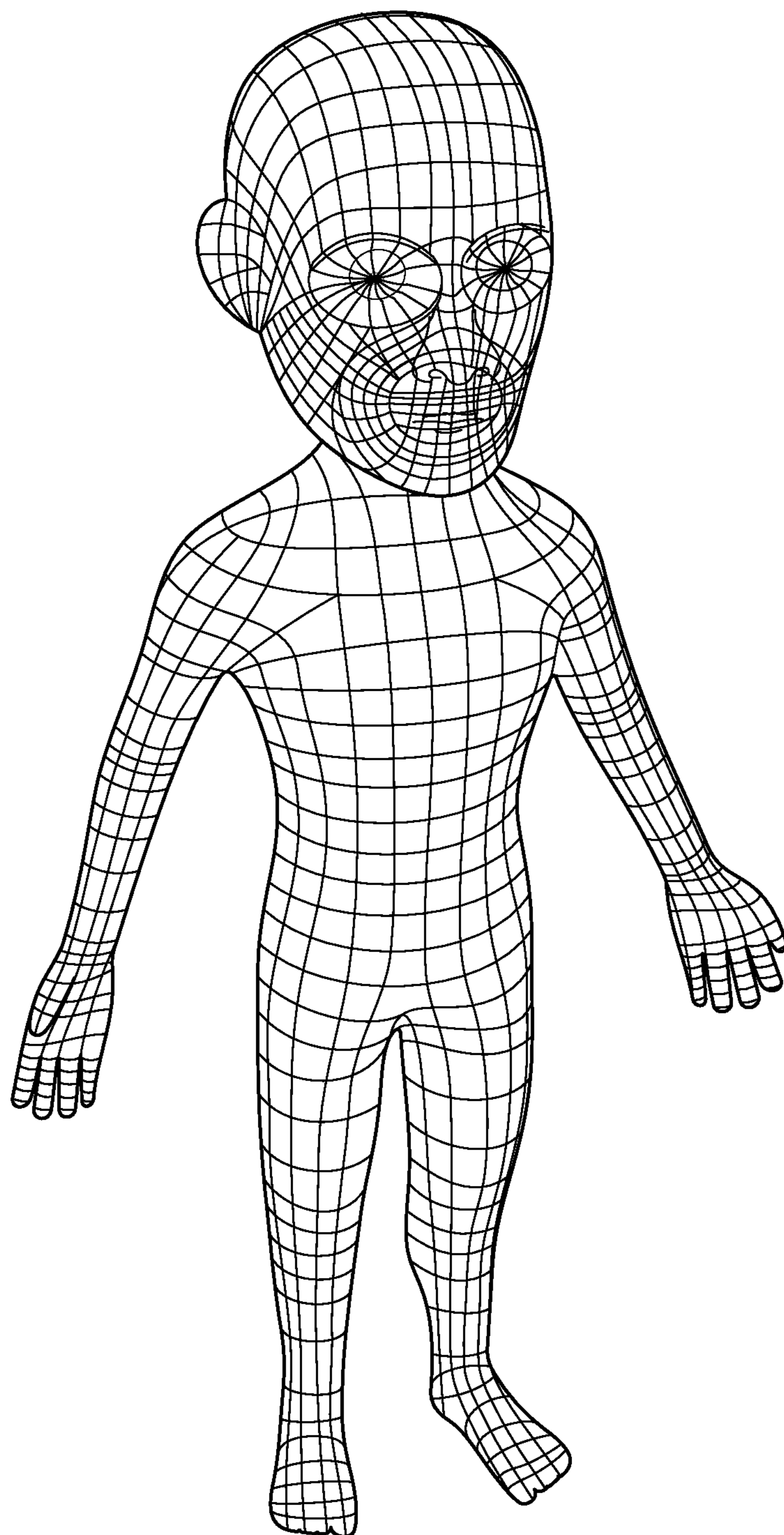

FIG. 6

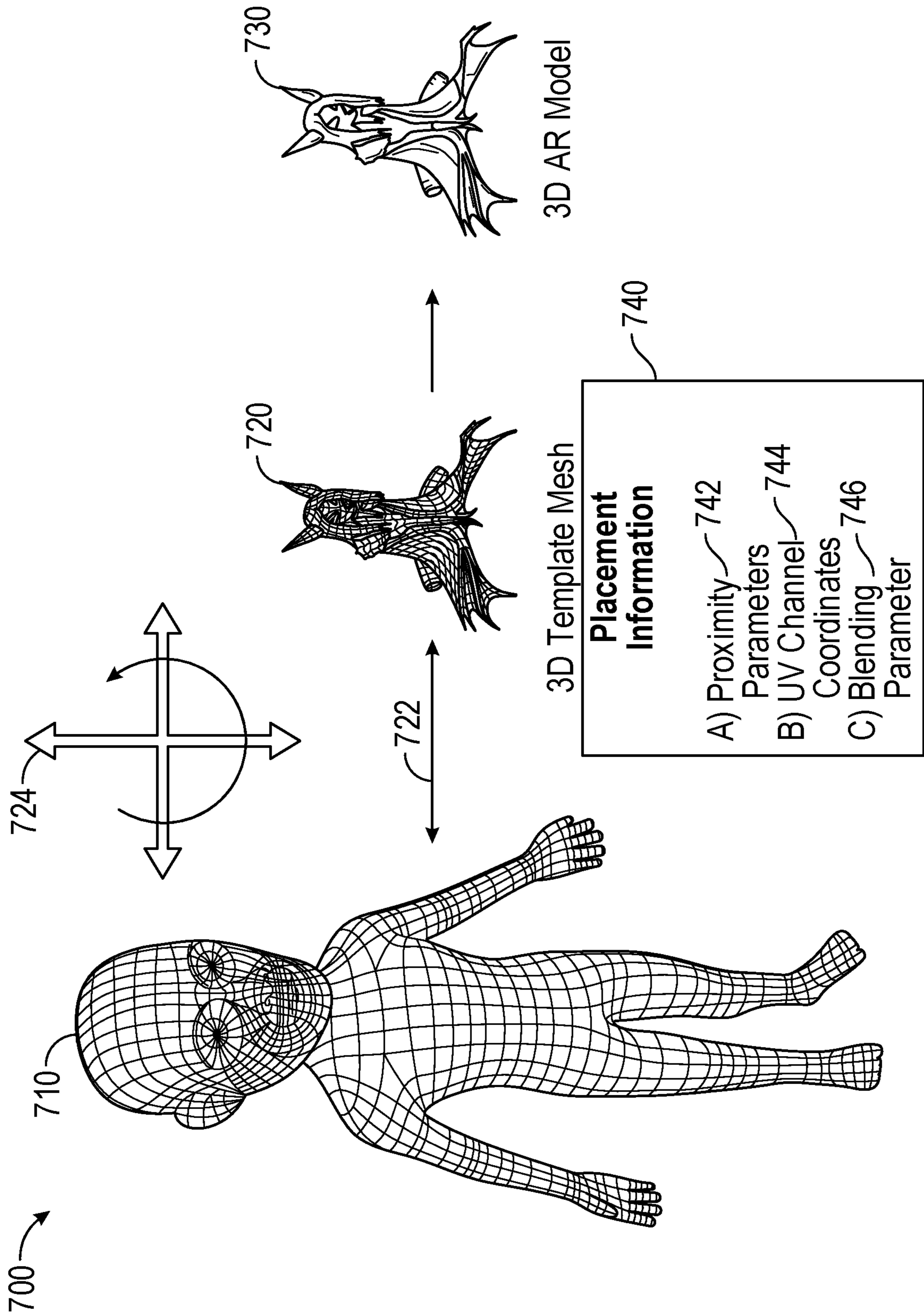

FIG. 7

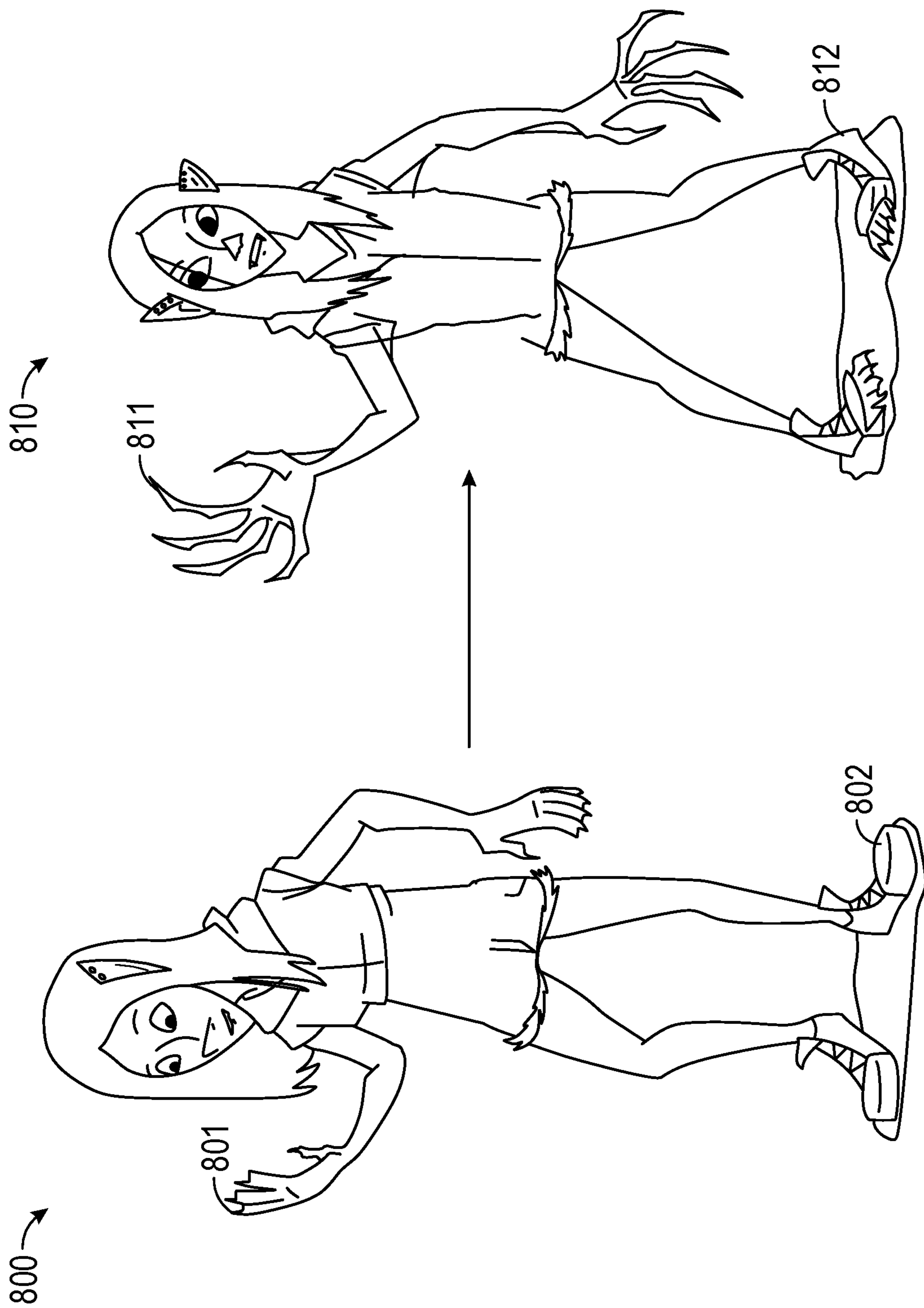

FIG. 8

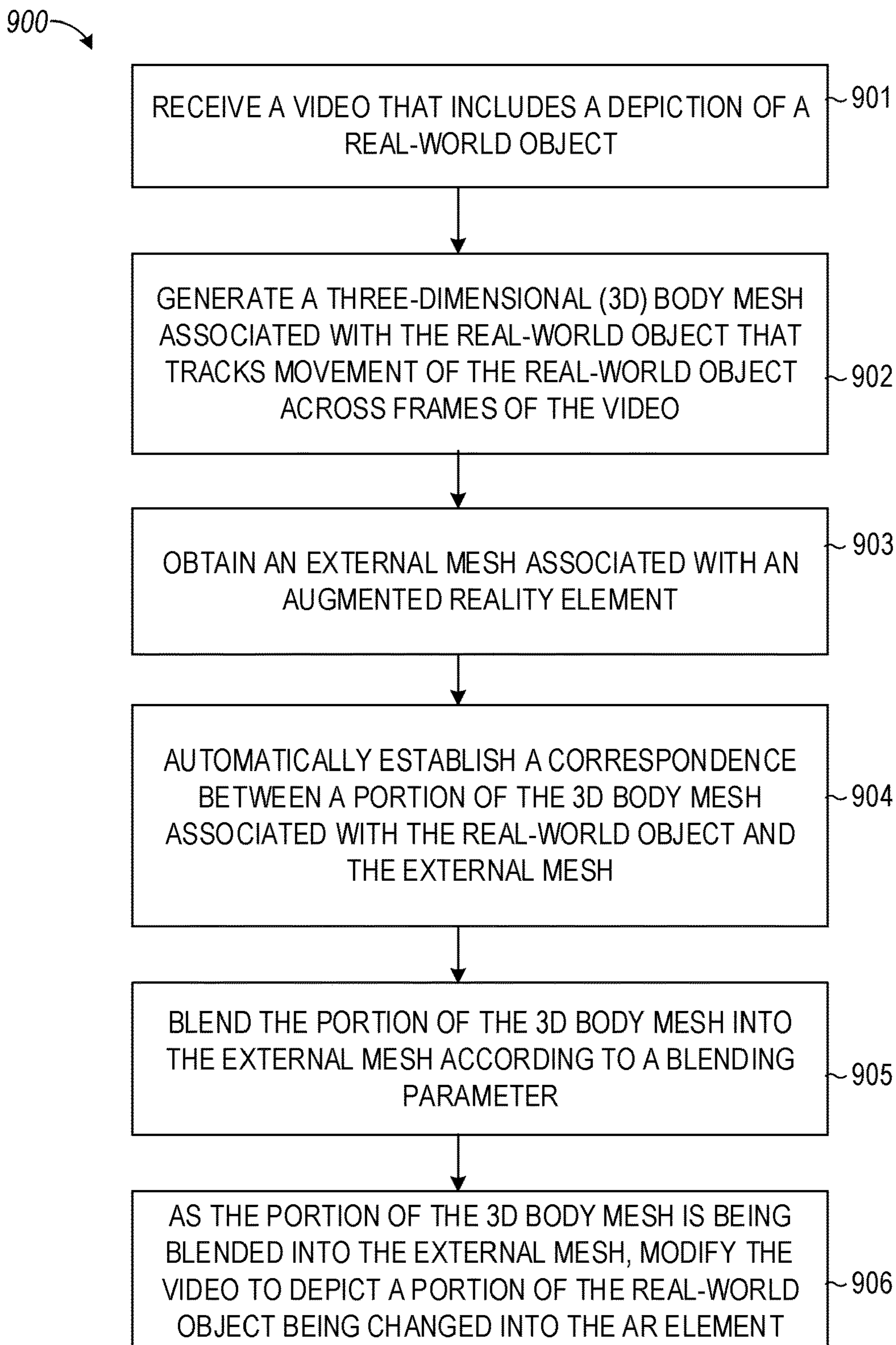

FIG. 9

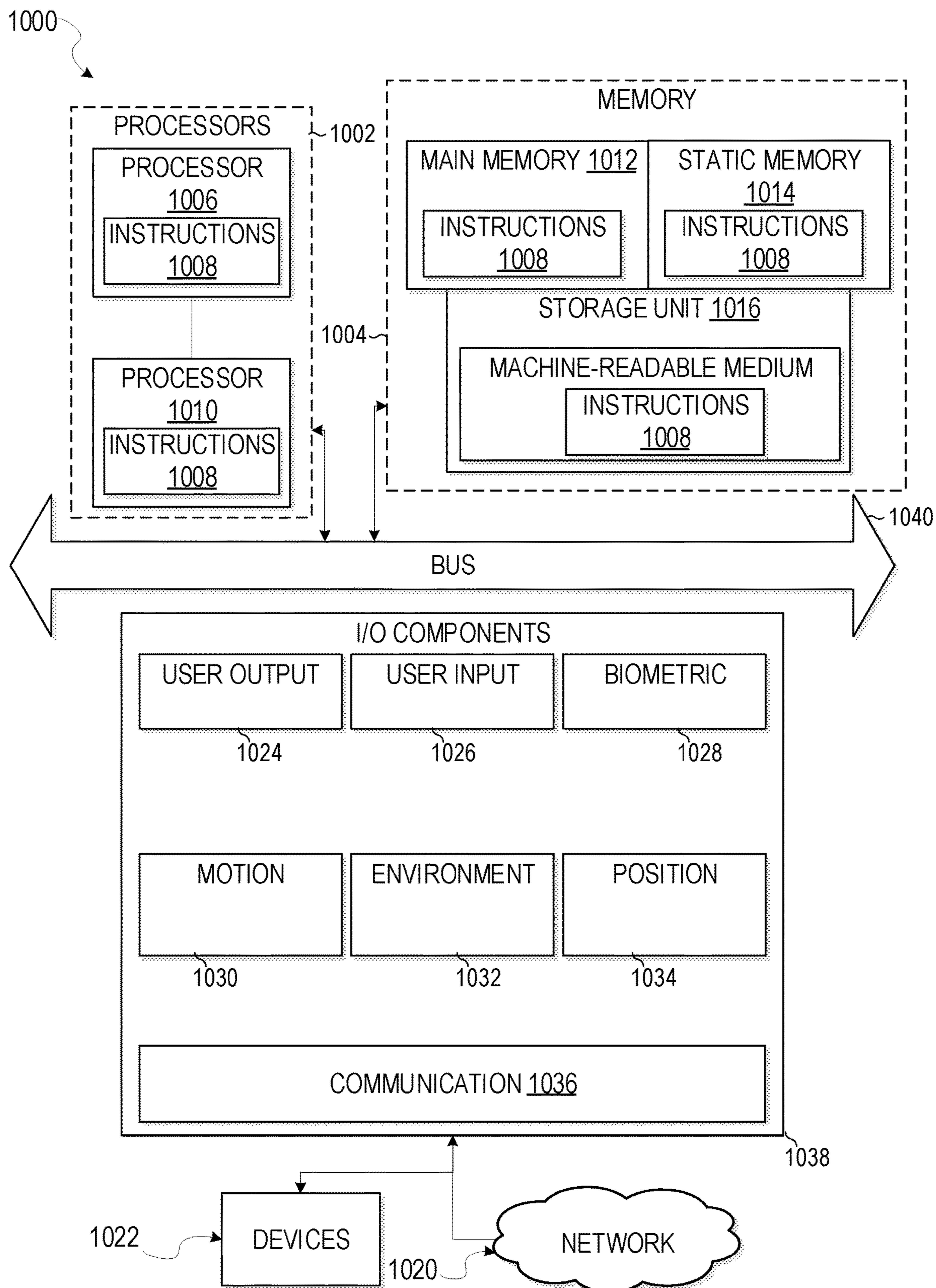

FIG. 10

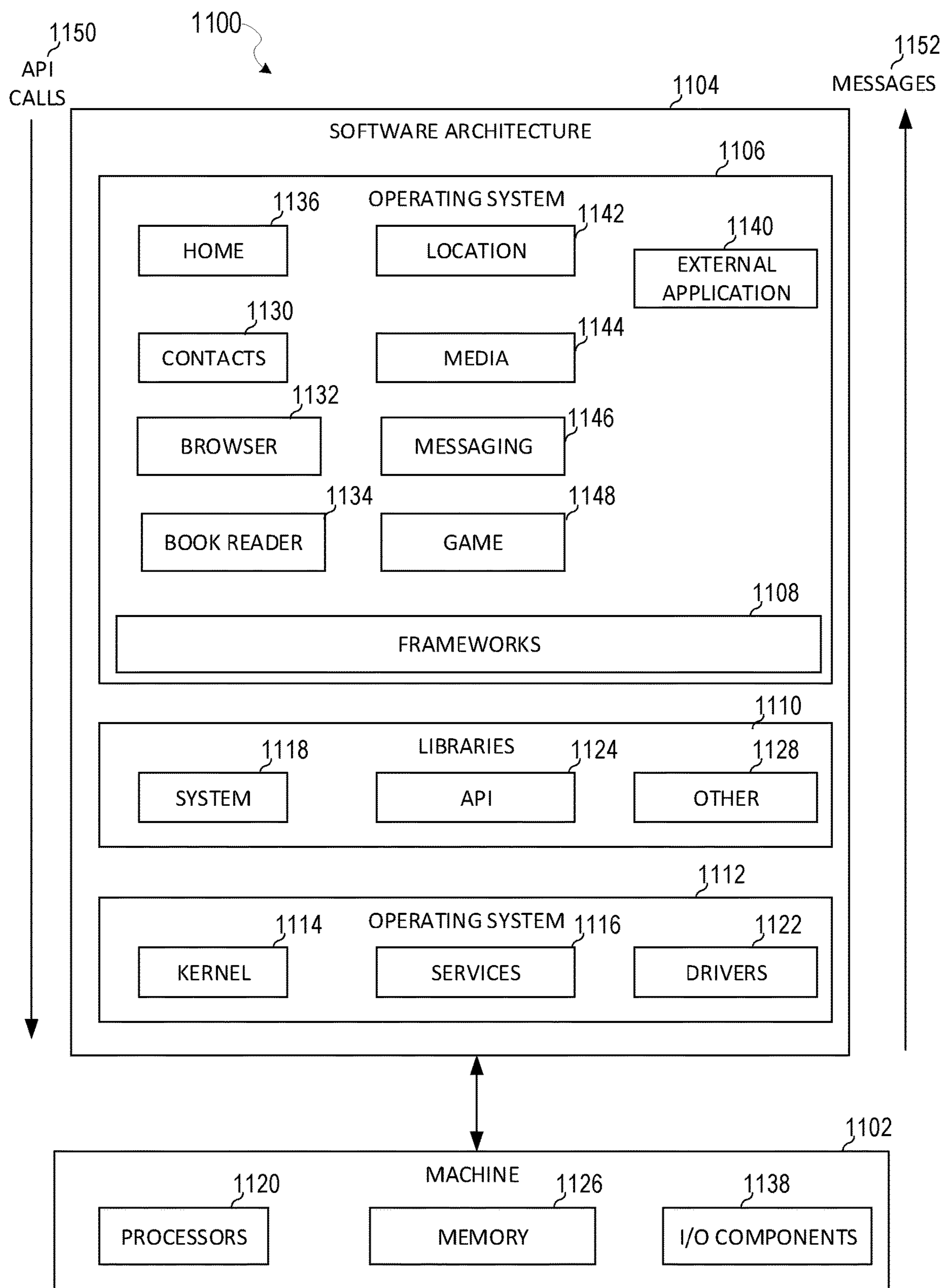

FIG. 11

BLENDING BODY MESH INTO EXTERNAL MESH

CLAIM OF PRIORITY

[0001] This application is a continuation of U.S. patent application Ser. No. 17/447,614, filed Sep. 14, 2021, which is incorporated herein by reference in its entirety.

TECHNICAL FIELD

[0002] The present disclosure relates generally to providing augmented reality experiences using a messaging application.

BACKGROUND

[0003] Augmented-Reality (AR) is a modification of a virtual environment. For example, in Virtual Reality (VR), a user is completely immersed in a virtual world, whereas in AR, the user is immersed in a world where virtual objects are combined or superimposed on the real world. An AR system aims to generate and present virtual objects that interact realistically with a real-world environment and with each other. Examples of AR applications can include single or multiple player video games, instant messaging systems, and the like.

BRIEF DESCRIPTION OF THE SEVERAL VIEWS OF THE DRAWINGS

[0004] In the drawings, which are not necessarily drawn to scale, like numerals may describe similar components in different views. To easily identify the discussion of any particular element or act, the most significant digit or digits in a reference number refer to the figure number in which that element is first introduced. Some nonlimiting examples are illustrated in the figures of the accompanying drawings in which:

[0005] FIG. 1 is a diagrammatic representation of a networked environment in which the present disclosure may be deployed, in accordance with some examples.

[0006] FIG. 2 is a diagrammatic representation of a messaging client application, in accordance with some examples.

[0007] FIG. 3 is a diagrammatic representation of a data structure as maintained in a database, in accordance with some examples.

[0008] FIG. 4 is a diagrammatic representation of a message, in accordance with some examples.

[0009] FIG. 5 is a block diagram showing an example external mesh deformation system, according to example examples.

[0010] FIGS. 6, 7, and 8 are diagrammatic representations of outputs of the external mesh deformation system, in accordance with some examples.

[0011] FIG. 9 is a flowchart illustrating example operations of the external mesh deformation system, according to some examples.

[0012] FIG. 10 is a diagrammatic representation of a machine in the form of a computer system within which a set of instructions may be executed for causing the machine to perform any one or more of the methodologies discussed herein, in accordance with some examples.

[0013] FIG. 11 is a block diagram showing a software architecture within which examples may be implemented.

DETAILED DESCRIPTION

[0014] The description that follows includes systems, methods, techniques, instruction sequences, and computing machine program products that embody illustrative examples of the disclosure. In the following description, for the purposes of explanation, numerous specific details are set forth in order to provide an understanding of various examples. It will be evident, however, to those skilled in the art, that examples may be practiced without these specific details. In general, well-known instruction instances, protocols, structures, and techniques are not necessarily shown in detail.

[0015] Typically, virtual reality (VR) and augmented reality (AR) systems display images representing a given user by capturing an image of the user and, in addition, obtaining a depth map using a depth sensor of the real-world human body depicted in the image. By processing the depth map and the image together, the VR and AR systems can detect positioning of a user in the image and can appropriately modify the user or background in the images. While such systems work well, the need for a depth sensor limits the scope of their applications. This is because adding depth sensors to user devices for the purpose of modifying images increases the overall cost and complexity of the devices, making them less attractive.

[0016] Certain systems do away with the need to use depth sensors to modify images. For example, certain systems allow users to replace a background in a videoconference in which a face of the user is detected. Specifically, such systems can use specialized techniques that are optimized for recognizing a face of a user to identify the background in the images that depict the user's face. These systems can then replace only those pixels that depict the background so that the real-world background is replaced with an alternate background in the images. Such systems though are generally incapable of recognizing a whole body of a user. As such, if the user is more than a threshold distance from the camera such that more than just the face of the user is captured by the camera, the replacement of the background with an alternate background begins to fail. In such cases, the image quality is severely impacted, and portions of the face and body of the user can be inadvertently removed by the system as the system falsely identifies such portions as belonging to the background rather than the foreground of the images. Also, such systems fail to properly replace the background when more than one user is depicted in the image or video feed. Because such systems are generally incapable of distinguishing a whole body of a user in an image from a background, these systems are also unable to apply visual effects to certain portions of a user's body, such as converting or morphing a body part (e.g., a face) into an AR graphic.

[0017] Some augmented reality (AR) systems allow AR graphics or AR elements to be added to an image or video to provide engaging AR experiences. Such systems can receive the AR graphics from a designer and can scale and position the AR graphics within the image or video. In order to improve the placement and positioning of the AR graphics on a person depicted in the image or video, such systems detect a person depicted in the image or video and generate a rig representing bones of the person. This rig is then used to adjust the AR graphics based on changes in movement to the rig. While such approaches generally work well, the need for generating a rig of a person in real time to adjust AR

graphics placement increases processing complexities and power and memory requirements. This makes such systems inefficient or incapable of running on small scale mobile devices without sacrificing computing resources or processing speed. Also, the rig only represents movement of skeletal or bone structures of a person in the image or video and does not take into account any sort of external physical properties of the person, such as density, weight, skin attributes, and so forth. As such, any AR graphics in these systems can be adjusted in scale and positioning but cannot be deformed based on other physical properties of the person. In addition, an AR graphics designer typically needs to create a compatible rig for their AR graphic.

[0018] The disclosed techniques improve the efficiency of using the electronic device by generating a body mesh of an object, such as a person, depicted in the image and deforming an external mesh in correspondence with the body mesh. By deforming an external mesh based on changes to the body mesh of a depicted object, the disclosed techniques can apply one or more visual effects to the image or video in association with the person depicted in the image or video in a more efficient manner and without the need for generating a rig or bone structures of the depicted object. Particularly, the disclosed techniques can morph, change, or blend one or more body parts of a person depicted in the image or video into one or more augmented reality elements taking into account movement and pose information of the person as determined by changes to the body mesh of the person.

[0019] This simplifies the process of adding AR graphics to an image or video which significantly reduces design constraints and costs in generating such AR graphics and decreases the amount of processing complexities and power and memory requirements. This also improves the illusion of the AR graphics being part of a real-world environment depicted in an image or video that depicts the object. This enables seamless and efficient addition of AR graphics to an underlying image or video in real time on small scale mobile devices. The disclosed techniques can be applied exclusively or mostly on a mobile device without the need for the mobile device to send images/videos to a server. In other examples, the disclosed techniques are applied exclusively or mostly on a remote server or can be divided between a mobile device and a server.

[0020] Also, the disclosed techniques allow an AR graphics designer to generate an external mesh for their AR graphics without creating a compatible rig for the AR graphics which saves time, effort, and creation complexity. The disclosed techniques enable the AR graphics (AR fashion items) to be deformed with the user's shape (weight, height, body shape, and so forth) by creating a correspondence between a body mesh and an external mesh of an AR graphic or AR fashion item. The disclosed techniques also enable certain portions of a real-world object to be blended or morphed into the AR graphics using correspondence information between the external mesh and body mesh and based on movement information associated with the body mesh.

[0021] As a result, a realistic display can be provided that shows the user being morphed into an AR graphic while moving around a video in 3D, including changes to the body shape, body state, body properties, position, and rotation, in a way that is intuitive for the user to interact with and select. As used herein, "article of clothing," "fashion item," and "garment" are used interchangeably and should be under-

stood to have the same meaning. This improves the overall experience of the user in using the electronic device. Also, by providing such AR experiences without using a depth sensor, the overall amount of system resources needed to accomplish a task is reduced.

Networked Computing Environment

[0022] FIG. 1 is a block diagram showing an example messaging system 100 for exchanging data (e.g., messages and associated content) over a network. The messaging system 100 includes multiple instances of a client device 102, each of which hosts a number of applications, including a messaging client 104 and other external applications 109 (e.g., third-party applications). Each messaging client 104 is communicatively coupled to other instances of the messaging client 104 (e.g., hosted on respective other client devices 102), a messaging server system 108 and external app(s) servers 110 via a network 112 (e.g., the Internet). A messaging client 104 can also communicate with locally-hosted third-party applications, such as external apps 109 using Application Programming Interfaces (APIs).

[0023] A messaging client 104 is able to communicate and exchange data with other messaging clients 104 and with the messaging server system 108 via the network 112. The data exchanged between messaging clients 104, and between a messaging client 104 and the messaging server system 108, includes functions (e.g., commands to invoke functions) as well as payload data (e.g., text, audio, video or other multimedia data).

[0024] The messaging server system 108 provides server-side functionality via the network 112 to a particular messaging client 104. While certain functions of the messaging system 100 are described herein as being performed by either a messaging client 104 or by the messaging server system 108, the location of certain functionality either within the messaging client 104 or the messaging server system 108 may be a design choice. For example, it may be technically preferable to initially deploy certain technology and functionality within the messaging server system 108 but to later migrate this technology and functionality to the messaging client 104 where a client device 102 has sufficient processing capacity.

[0025] The messaging server system 108 supports various services and operations that are provided to the messaging client 104. Such operations include transmitting data to, receiving data from, and processing data generated by the messaging client 104. This data may include message content, client device information, geolocation information, media augmentation and overlays, message content persistence conditions, social network information, and live event information, as examples. Data exchanges within the messaging system 100 are invoked and controlled through functions available via user interfaces (UIs) of the messaging client 104.

[0026] Turning now specifically to the messaging server system 108, an Application Programming Interface (API) server 116 is coupled to, and provides a programmatic interface to, application servers 114. The application servers 114 are communicatively coupled to a database server 120, which facilitates access to a database 126 that stores data associated with messages processed by the application servers 114. Similarly, a web server 128 is coupled to the application servers 114, and provides web-based interfaces to the application servers 114. To this end, the web server

128 processes incoming network requests over the Hypertext Transfer Protocol (HTTP) and several other related protocols.

[0027] The API server **116** receives and transmits message data (e.g., commands and message payloads) between the client device **102** and the application servers **114**. Specifically, the API server **116** provides a set of interfaces (e.g., routines and protocols) that can be called or queried by the messaging client **104** in order to invoke functionality of the application servers **114**. The API server **116** exposes various functions supported by the application servers **114**, including account registration, login functionality, the sending of messages, via the application servers **114**, from a particular messaging client **104** to another messaging client **104**, the sending of media files (e.g., images or video) from a messaging client **104** to a messaging server **118**, and for possible access by another messaging client **104**, the settings of a collection of media data (e.g., story), the retrieval of a list of friends of a user of a client device **102**, the retrieval of such collections, the retrieval of messages and content, the addition and deletion of entities (e.g., friends) to an entity graph (e.g., a social graph), the location of friends within a social graph, and opening an application event (e.g., relating to the messaging client **104**).

[0028] The application servers **114** host a number of server applications and subsystems, including for example a messaging server **118**, an image processing server **122**, and a social network server **124**. The messaging server **118** implements a number of message processing technologies and functions, particularly related to the aggregation and other processing of content (e.g., textual and multimedia content) included in messages received from multiple instances of the messaging client **104**. As will be described in further detail, the text and media content from multiple sources may be aggregated into collections of content (e.g., called stories or galleries). These collections are then made available to the messaging client **104**. Other processor- and memory-intensive processing of data may also be performed server-side by the messaging server **118**, in view of the hardware requirements for such processing.

[0029] The application servers **114** also include an image processing server **122** that is dedicated to performing various image processing operations, typically with respect to images or video within the payload of a message sent from or received at the messaging server **118**.

[0030] Image processing server **122** is used to implement scan functionality of the augmentation system **208** (shown in FIG. 2). Scan functionality includes activating and providing one or more augmented reality experiences on a client device **102** when an image is captured by the client device **102**. Specifically, the messaging client **104** on the client device **102** can be used to activate a camera. The camera displays one or more real-time images or a video to a user along with one or more icons or identifiers of one or more augmented reality experiences. The user can select a given one of the identifiers to launch the corresponding augmented reality experience or perform a desired image modification (e.g., replace a garment being worn by a user in a video or morph, change, blend, or transform a portion of a body of a person or user into an AR graphic, such as an AR werewolf or AR bat).

[0031] The social network server **124** supports various social networking functions and services and makes these functions and services available to the messaging server **118**.

To this end, the social network server **124** maintains and accesses an entity graph **308** (as shown in FIG. 3) within the database **126**. Examples of functions and services supported by the social network server **124** include the identification of other users of the messaging system **100** with which a particular user has relationships or is “following,” and also the identification of other entities and interests of a particular user.

[0032] Returning to the messaging client **104**, features and functions of an external resource (e.g., a third-party application **109** or applet) are made available to a user via an interface of the messaging client **104**. The messaging client **104** receives a user selection of an option to launch or access features of an external resource (e.g., a third-party resource), such as external apps **109**. The external resource may be a third-party application (external apps **109**) installed on the client device **102** (e.g., a “native app”), or a small-scale version of the third-party application (e.g., an “applet”) that is hosted on the client device **102** or remote of the client device **102** (e.g., on third-party servers **110**). The small-scale version of the third-party application includes a subset of features and functions of the third-party application (e.g., the full-scale, native version of the third-party standalone application) and is implemented using a markup-language document. In one example, the small-scale version of the third-party application (e.g., an “applet”) is a web-based, markup-language version of the third-party application and is embedded in the messaging client **104**. In addition to using markup-language documents (e.g., a *.ml file), an applet may incorporate a scripting language (e.g., a *.js file or a .json file) and a style sheet (e.g., a *.ss file).

[0033] In response to receiving a user selection of the option to launch or access features of the external resource (external app **109**), the messaging client **104** determines whether the selected external resource is a web-based external resource or a locally-installed external application. In some cases, external applications **109** that are locally installed on the client device **102** can be launched independently of and separately from the messaging client **104**, such as by selecting an icon, corresponding to the external application **109**, on a home screen of the client device **102**. Small-scale versions of such external applications can be launched or accessed via the messaging client **104** and, in some examples, no or limited portions of the small-scale external application can be accessed outside of the messaging client **104**. The small-scale external application can be launched by the messaging client **104** receiving, from an external app(s) server **110**, a markup-language document associated with the small-scale external application and processing such a document.

[0034] In response to determining that the external resource is a locally-installed external application **109**, the messaging client **104** instructs the client device **102** to launch the external application **109** by executing locally-stored code corresponding to the external application **109**. In response to determining that the external resource is a web-based resource, the messaging client **104** communicates with the external app(s) servers **110** to obtain a markup-language document corresponding to the selected resource. The messaging client **104** then processes the obtained markup-language document to present the web-based external resource within a user interface of the messaging client **104**.

[0035] The messaging client **104** can notify a user of the client device **102**, or other users related to such a user (e.g., “friends”), of activity taking place in one or more external resources. For example, the messaging client **104** can provide participants in a conversation (e.g., a chat session) in the messaging client **104** with notifications relating to the current or recent use of an external resource by one or more members of a group of users. One or more users can be invited to join in an active external resource or to launch a recently-used but currently inactive (in the group of friends) external resource. The external resource can provide participants in a conversation, each using a respective messaging client **104**, with the ability to share an item, status, state, or location in an external resource with one or more members of a group of users into a chat session. The shared item may be an interactive chat card with which members of the chat can interact, for example, to launch the corresponding external resource, view specific information within the external resource, or take the member of the chat to a specific location or state within the external resource. Within a given external resource, response messages can be sent to users on the messaging client **104**. The external resource can selectively include different media items in the responses, based on a current context of the external resource.

[0036] The messaging client **104** can present a list of the available external resources (e.g., third-party or external applications **109** or applets) to a user to launch or access a given external resource. This list can be presented in a context-sensitive menu. For example, the icons representing different ones of the external application **109** (or applets) can vary based on how the menu is launched by the user (e.g., from a conversation interface or from a non-conversation interface).

[0037] The messaging client **104** can present to a user one or more AR experiences. As an example, the messaging client **104** can detect a person or user in an image or video captured by the client device **102**. The messaging client **104** can generate a body mesh for the person depicted in the image or video. The body mesh can be a 3D mesh, or polygon mesh, that includes a collection of vertices, edges, and faces that define the shape of a polyhedral object depicted in the image or video. The mesh can be a collection of several closed surfaces. In a mathematical vector algebraic sense, which may be important for calculations, a mesh can be a collection of numbers organized into several matrices. In a geometric description, a mesh can be made of points that are joined together with segments and surfaced by polygons.

[0038] The messaging client **104** can receive a user selection of an AR graphic to add to the image or video, such as to blend a portion the user or person (e.g., a body part, such as a hand, head, legs, torso, or any combination thereof) into the AR graphic. The messaging client **104** can obtain an external mesh associated with the AR graphic. The AR graphic can represent a fashion accessory, an AR animal, an AR superhero or other item or graphic that can be used to control morphing, changing, transforming, or blending of a portion of an object, such as an animal, user, or person into the item or graphic. For example, the AR graphic can represent a werewolf (such as a head of the werewolf and/or the entire body of the werewolf). The external mesh associated with the AR graphic can include blending parameter information for controlling how a real-world object portion is morphed, blended, changed, or transformed into the

werewolf or AR graphic. The blending parameter can include a linear or non-linear function that controls how quickly or slowly the real-world object portion is blended into the AR graphic or werewolf. The AR graphic can also include information indicating which portions of the object, person, or user to blend into the AR graphic and which portions to not change. For example, the AR graphic can specify that the head of the object, person, or user is to be transformed into the head of the werewolf without changing or affecting other portions of the object, person, or user (e.g., the arms, legs, hands, and torso).

[0039] The messaging client **104** can automatically establish a correspondence between the body mesh (e.g., 3D body mesh) and the external mesh. The messaging client **104** can position the external mesh over or with respect to the 3D body mesh within the image or video. The messaging client **104** can determine (based on placement information associated with the external mesh) a first portion or first set of portions of the external mesh that are deformed based on movement information associated with the 3D body mesh. For example, if the AR graphic is a head of an animal or AR werewolf, the placement information can specify that the head portion of the external mesh (the portion of the external mesh corresponding to a head of the animal or AR werewolf) is to be deformed based on movement information associated with the head portion of the 3D body mesh. The messaging client **104** can then blend, transform, morph, or change the head portion of the 3D body mesh into the AR graphic according to the blending parameter while deforming the external mesh based on movement information of the 3D body mesh. This allows the object, user, or person depicted in the image or video to continue to move around while a portion of the object, user, or person is blended, morphed, transformed, or changed into the AR graphic. This provides the user with a realistic display of the image or video depiction of the person combined with the selected AR graphic. While the disclosed examples are discussed in relation to an AR animal into which a portion of an object, user, or person depicted in an image or video is morphed, transformed, blended, or changed, similar techniques can be applied to any other AR graphic or AR item, such as an image, cartoon, character, other user, fictional item, real-world item, furniture, video, and so forth.

[0040] In this way, the messaging client **104** can adjust an external mesh (and as a result the AR graphic associated with the external mesh) in real time based on movements and other changes (e.g., changes to the body shape, position, rotation, and scale) of a body mesh associated with an object, such as a person, depicted in the image or video and while also blending a portion of the real-world object into the AR graphic according to a blending parameter (e.g., a linear or non-linear function). This provides an illusion that the AR graphic is actually included in the real-world environment depicted in the image or video which improves the overall user experience. Further details of the deformation of the external mesh with respect to the body mesh and blending parameters are provided below in connection with FIG. 5.

System Architecture

[0041] FIG. 2 is a block diagram illustrating further details regarding the messaging system **100**, according to some examples. Specifically, the messaging system **100** is shown to comprise the messaging client **104** and the application

servers **114**. The messaging system **100** embodies a number of subsystems, which are supported on the client side by the messaging client **104** and on the sever side by the application servers **114**. These subsystems include, for example, an ephemeral timer system **202**, a collection management system **204**, an augmentation system **208**, a map system **210**, a game system **212**, and an external resource system **220**.

[0042] The ephemeral timer system **202** is responsible for enforcing the temporary or time-limited access to content by the messaging client **104** and the messaging server **118**. The ephemeral timer system **202** incorporates a number of timers that, based on duration and display parameters associated with a message, or collection of messages (e.g., a story), selectively enable access (e.g., for presentation and display) to messages and associated content via the messaging client **104**. Further details regarding the operation of the ephemeral timer system **202** are provided below.

[0043] The collection management system **204** is responsible for managing sets or collections of media (e.g., collections of text, image video, and audio data). A collection of content (e.g., messages, including images, video, text, and audio) may be organized into an “event gallery” or an “event story.” Such a collection may be made available for a specified time period, such as the duration of an event to which the content relates. For example, content relating to a music concert may be made available as a “story” for the duration of that music concert. The collection management system **204** may also be responsible for publishing an icon that provides notification of the existence of a particular collection to the user interface of the messaging client **104**.

[0044] The collection management system **204** further includes a curation interface **206** that allows a collection manager to manage and curate a particular collection of content. For example, the curation interface **206** enables an event organizer to curate a collection of content relating to a specific event (e.g., delete inappropriate content or redundant messages). Additionally, the collection management system **204** employs machine vision (or image recognition technology) and content rules to automatically curate a content collection. In certain examples, compensation may be paid to a user for the inclusion of user-generated content into a collection. In such cases, the collection management system **204** operates to automatically make payments to such users for the use of their content.

[0045] The augmentation system **208** provides various functions that enable a user to augment (e.g., annotate or otherwise modify or edit) media content associated with a message. For example, the augmentation system **208** provides functions related to the generation and publishing of media overlays for messages processed by the messaging system **100**. The augmentation system **208** operatively supplies a media overlay or augmentation (e.g., an image filter) to the messaging client **104** based on a geolocation of the client device **102**. In another example, the augmentation system **208** operatively supplies a media overlay to the messaging client **104** based on other information, such as social network information of the user of the client device **102**. A media overlay may include audio and visual content and visual effects. Examples of audio and visual content include pictures, texts, logos, animations, and sound effects. An example of a visual effect includes color overlaying. The audio and visual content or the visual effects can be applied to a media content item (e.g., a photo) at the client device **102**. For example, the media overlay may include text, a

graphical element, or image that can be overlaid on top of a photograph taken by the client device **102**. In another example, the media overlay includes an identification of a location overlay (e.g., Venice beach), a name of a live event, or a name of a merchant overlay (e.g., Beach Coffee House). In another example, the augmentation system **208** uses the geolocation of the client device **102** to identify a media overlay that includes the name of a merchant at the geolocation of the client device **102**. The media overlay may include other indicia associated with the merchant. The media overlays may be stored in the database **126** and accessed through the database server **120**.

[0046] In some examples, the augmentation system **208** provides a user-based publication platform that enables users to select a geolocation on a map and upload content associated with the selected geolocation. The user may also specify circumstances under which a particular media overlay should be offered to other users. The augmentation system **208** generates a media overlay that includes the uploaded content and associates the uploaded content with the selected geolocation.

[0047] In other examples, the augmentation system **208** provides a merchant-based publication platform that enables merchants to select a particular media overlay associated with a geolocation via a bidding process. For example, the augmentation system **208** associates the media overlay of the highest bidding merchant with a corresponding geolocation for a predefined amount of time. The augmentation system **208** communicates with the image processing server **122** to obtain augmented reality experiences and presents identifiers of such experiences in one or more user interfaces (e.g., as icons over a real-time image or video or as thumbnails or icons in interfaces dedicated for presented identifiers of augmented reality experiences). Once an augmented reality experience is selected, one or more images, videos, or augmented reality graphical elements are retrieved and presented as an overlay on top of the images or video captured by the client device **102**. In some cases, the camera is switched to a front-facing view (e.g., the front-facing camera of the client device **102** is activated in response to activation of a particular augmented reality experience) and the images from the front-facing camera of the client device **102** start being displayed on the client device **102** instead of the rear-facing camera of the client device **102**. The one or more images, videos, or augmented reality graphical elements are retrieved and presented as an overlay on top of the images that are captured and displayed by the front-facing camera of the client device **102**.

[0048] In other examples, the augmentation system **208** is able to communicate and exchange data with another augmentation system **208** on another client device **102** and with the server via the network **112**. The data exchanged can include a session identifier that identifies the shared AR session, a transformation between a first client device **102** and a second client device **102** (e.g., a plurality of client devices **102** include the first and second devices) that is used to align the shared AR session to a common point of origin, a common coordinate frame, functions (e.g., commands to invoke functions) as well as other payload data (e.g., text, audio, video or other multimedia data).

[0049] The augmentation system **208** sends the transformation to the second client device **102** so that the second client device **102** can adjust the AR coordinate system based on the transformation. In this way, the first and second client

devices **102** synch up their coordinate systems and frames for displaying content in the AR session. Specifically, the augmentation system **208** computes the point of origin of the second client device **102** in the coordinate system of the first client device **102**. The augmentation system **208** can then determine an offset in the coordinate system of the second client device **102** based on the position of the point of origin from the perspective of the second client device **102** in the coordinate system of the second client device **102**. This offset is used to generate the transformation so that the second client device **102** generates AR content according to a common coordinate system or frame as the first client device **102**.

[0050] The augmentation system **208** can communicate with the client device **102** to establish individual or shared AR sessions. The augmentation system **208** can also be coupled to the messaging server **118** to establish an electronic group communication session (e.g., group chat, instant messaging) for the client devices **102** in a shared AR session. The electronic group communication session can be associated with a session identifier provided by the client devices **102** to gain access to the electronic group communication session and to the shared AR session. In one example, the client devices **102** first gain access to the electronic group communication session and then obtain the session identifier in the electronic group communication session that allows the client devices **102** to access the shared AR session. In some examples, the client devices **102** are able to access the shared AR session without aid or communication with the augmentation system **208** in the application servers **114**.

[0051] The map system **210** provides various geographic location functions, and supports the presentation of map-based media content and messages by the messaging client **104**. For example, the map system **210** enables the display of user icons or avatars (e.g., stored in profile data **316**) on a map to indicate a current or past location of “friends” of a user, as well as media content (e.g., collections of messages including photographs and videos) generated by such friends, within the context of a map. For example, a message posted by a user to the messaging system **100** from a specific geographic location may be displayed within the context of a map at that particular location to “friends” of a specific user on a map interface of the messaging client **104**. A user can furthermore share his or her location and status information (e.g., using an appropriate status avatar) with other users of the messaging system **100** via the messaging client **104**, with this location and status information being similarly displayed within the context of a map interface of the messaging client **104** to selected users.

[0052] The game system **212** provides various gaming functions within the context of the messaging client **104**. The messaging client **104** provides a game interface providing a list of available games (e.g., web-based games or web-based applications) that can be launched by a user within the context of the messaging client **104**, and played with other users of the messaging system **100**. The messaging system **100** further enables a particular user to invite other users to participate in the play of a specific game, by issuing invitations to such other users from the messaging client **104**. The messaging client **104** also supports both voice and text messaging (e.g., chats) within the context of

gameplay, provides a leaderboard for the games, and also supports the provision of in-game rewards (e.g., coins and items).

[0053] The external resource system **220** provides an interface for the messaging client **104** to communicate with external app(s) servers **110** to launch or access external resources. Each external resource (apps) server **110** hosts, for example, a markup language (e.g., HTML5) based application or small-scale version of an external application (e.g., game, utility, payment, or ride-sharing application that is external to the messaging client **104**). The messaging client **104** may launch a web-based resource (e.g., application) by accessing the HTML5 file from the external resource (apps) servers **110** associated with the web-based resource. In certain examples, applications hosted by external resource servers **110** are programmed in JavaScript leveraging a Software Development Kit (SDK) provided by the messaging server **118**. The SDK includes Application Programming Interfaces (APIs) with functions that can be called or invoked by the web-based application. In certain examples, the messaging server **118** includes a JavaScript library that provides a given third-party resource access to certain user data of the messaging client **104**. HTML5 is used as an example technology for programming games, but applications and resources programmed based on other technologies can be used.

[0054] In order to integrate the functions of the SDK into the web-based resource, the SDK is downloaded by an external resource (apps) server **110** from the messaging server **118** or is otherwise received by the external resource (apps) server **110**. Once downloaded or received, the SDK is included as part of the application code of a web-based external resource. The code of the web-based resource can then call or invoke certain functions of the SDK to integrate features of the messaging client **104** into the web-based resource.

[0055] The SDK stored on the messaging server **118** effectively provides the bridge between an external resource (e.g., third-party or external applications **109** or applets and the messaging client **104**). This provides the user with a seamless experience of communicating with other users on the messaging client **104**, while also preserving the look and feel of the messaging client **104**. To bridge communications between an external resource and a messaging client **104**, in certain examples, the SDK facilitates communication between external resource servers **110** and the messaging client **104**. In certain examples, a WebViewJavaScriptBridge running on a client device **102** establishes two one-way communication channels between an external resource and the messaging client **104**. Messages are sent between the external resource and the messaging client **104** via these communication channels asynchronously. Each SDK function invocation is sent as a message and callback. Each SDK function is implemented by constructing a unique callback identifier and sending a message with that callback identifier.

[0056] By using the SDK, not all information from the messaging client **104** is shared with external resource servers **110**. The SDK limits which information is shared based on the needs of the external resource. In certain examples, each external resource server **110** provides an HTML5 file corresponding to the web-based external resource to the messaging server **118**. The messaging server **118** can add a visual representation (such as a box art or other graphic) of

the web-based external resource in the messaging client **104**. Once the user selects the visual representation or instructs the messaging client **104** through a GUI of the messaging client **104** to access features of the web-based external resource, the messaging client **104** obtains the HTML5 file and instantiates the resources necessary to access the features of the web-based external resource.

[0057] The messaging client **104** presents a graphical user interface (e.g., a landing page or title screen) for an external resource. During, before, or after presenting the landing page or title screen, the messaging client **104** determines whether the launched external resource has been previously authorized to access user data of the messaging client **104**. In response to determining that the launched external resource has been previously authorized to access user data of the messaging client **104**, the messaging client **104** presents another graphical user interface of the external resource that includes functions and features of the external resource. In response to determining that the launched external resource has not been previously authorized to access user data of the messaging client **104**, after a threshold period of time (e.g., 3 seconds) of displaying the landing page or title screen of the external resource, the messaging client **104** slides up (e.g., animates a menu as surfacing from a bottom of the screen to a middle of or other portion of the screen) a menu for authorizing the external resource to access the user data. The menu identifies the type of user data that the external resource will be authorized to use. In response to receiving a user selection of an accept option, the messaging client **104** adds the external resource to a list of authorized external resources and allows the external resource to access user data from the messaging client **104**. In some examples, the external resource is authorized by the messaging client **104** to access the user data in accordance with an OAuth 2 framework.

[0058] The messaging client **104** controls the type of user data that is shared with external resources based on the type of external resource being authorized. For example, external resources that include full-scale external applications (e.g., a third-party or external application **109**) are provided with access to a first type of user data (e.g., only two-dimensional avatars of users with or without different avatar characteristics). As another example, external resources that include small-scale versions of external applications (e.g., web-based versions of third-party applications) are provided with access to a second type of user data (e.g., payment information, two-dimensional avatars of users, three-dimensional avatars of users, and avatars with various avatar characteristics). Avatar characteristics include different ways to customize a look and feel of an avatar, such as different poses, facial features, clothing, and so forth.

[0059] The external mesh deformation system **224** deforms an external mesh based on changes to a 3D body mesh of a real-world object depicted in an image or video in real time and morphs, changes, transforms, or blends at least a portion of the real-world object into the AR graphic represented by the external mesh. In an example, the external mesh deformation system **224** can receive a selection of an AR graphic, such as an AR werewolf. The external mesh deformation system **224** identifies a body part of the real-world object depicted in the image or video that corresponds to the AR graphic, such as based on placement information associated with the AR graphic. The external mesh deformation system **224** deforms the external mesh corresponding

to the AR graphic based on movement information associated with the 3D body mesh. The external mesh deformation system **224** obtains a blending parameter and changes, blends, deforms, transforms, or morphs at least the body part of the 3D body mesh of the real-world object into the external mesh while continuing to update and deform the external mesh based on movement information associated with the 3D body mesh.

[0060] In one example, the external mesh deformation system **224** changes, blends, deforms, transforms, or morphs at least the body part of the 3D body mesh of the real-world object into the external mesh linearly over a given time interval, such that updates to the 3D body mesh are being made repeatedly at equally spaced time points. In another example, the external mesh deformation system **224** changes, blends, deforms, transforms, or morphs at least the 3D body mesh of the body part of the real-world object into the external mesh non-linearly over a given time interval, such that a first set of updates to the real-world body part of the 3D body mesh are being made at a first rate, such as repeatedly at equally spaced time points to create a partially blended 3D body mesh. Subsequently, the first rate is modified (increased or decreased) so that a second set of updates to the partially blended real-world 3D body mesh continue to be made at a faster or slower pace until the real-world body part of the 3D body mesh is completely transformed into the external mesh (e.g., into the AR graphic). As a result, the external mesh deformation system **224** continuously or periodically represents and depicts changes to the body part in the image or video to represent the body part being morphed, changed, blended, or transformed into the AR werewolf. An illustrative implementation of the external mesh deformation system **224** is shown and described in connection with FIG. 5 below.

[0061] Specifically, the external mesh deformation system **224** is a component that can be accessed by an AR/VR application implemented on the client device **102**. The AR/VR application uses an RGB camera to capture a monocular image of a user. The AR/VR application applies various trained machine learning techniques on the captured image of the user to generate a 3D body mesh representing the user depicted in the image and to apply one or more AR visual effects to the captured image by deforming one or more external meshes associated with the AR visual effects. In some implementations, the AR/VR application continuously captures images of the user and updates the 3D body mesh and external mesh(es) in real time or periodically to continuously or periodically update the applied one or more visual effects. This allows the user to move around in the real world and see the one or more visual effects update in real time. In some examples, the external mesh deformation system **224** automatically establishes a correspondence between the external mesh and the 3D body mesh once prior to runtime (e.g., before the AR graphics are presented to the user) and then the external mesh and the 3D body mesh are deformed with respect to each other during runtime to update the display of the AR graphics associated with the external mesh. In other examples, the automated correspondence can continuously be updated and generated during runtime while also deforming the external mesh.

[0062] In training, the external mesh deformation system **224** obtains a first plurality of input training images that include depictions of one or more users having different body types and characteristics. These training images also

provide the ground truth information including body meshes corresponding to the one or more users depicted in each image. A machine learning technique (e.g., a deep neural network) is trained based on features of the plurality of training images. Specifically, the machine learning technique extracts one or more features from a given training image and estimates a 3D body mesh for the user depicted in the given training image. The machine learning technique obtains the ground truth information including the 3D body mesh corresponding to the training image and adjusts or updates one or more coefficients or parameters to improve subsequent estimations of body meshes.

Data Architecture

[0063] FIG. 3 is a schematic diagram illustrating data structures 300, which may be stored in the database 126 of the messaging server system 108, according to certain examples. While the content of the database 126 is shown to comprise a number of tables, it will be appreciated that the data could be stored in other types of data structures (e.g., as an object-oriented database).

[0064] The database 126 includes message data stored within a message table 302. This message data includes, for any particular one message, at least message sender data, message recipient (or receiver) data, and a payload. Further details regarding information that may be included in a message, and included within the message data stored in the message table 302, are described below with reference to FIG. 4.

[0065] An entity table 306 stores entity data, and is linked (e.g., referentially) to an entity graph 308 and profile data 316. Entities for which records are maintained within the entity table 306 may include individuals, corporate entities, organizations, objects, places, events, and so forth. Regardless of entity type, any entity regarding which the messaging server system 108 stores data may be a recognized entity. Each entity is provided with a unique identifier, as well as an entity type identifier (not shown).

[0066] The entity graph 308 stores information regarding relationships and associations between entities. Such relationships may be social, professional (e.g., work at a common corporation or organization) interested-based or activity-based, merely for example.

[0067] The profile data 316 stores multiple types of profile data about a particular entity. The profile data 316 may be selectively used and presented to other users of the messaging system 100, based on privacy settings specified by a particular entity. Where the entity is an individual, the profile data 316 includes, for example, a user name, telephone number, address, settings (e.g., notification and privacy settings), as well as a user-selected avatar representation (or collection of such avatar representations). A particular user may then selectively include one or more of these avatar representations within the content of messages communicated via the messaging system 100, and on map interfaces displayed by messaging clients 104 to other users. The collection of avatar representations may include “status avatars,” which present a graphical representation of a status or activity that the user may select to communicate at a particular time.

[0068] Where the entity is a group, the profile data 316 for the group may similarly include one or more avatar repre-

sentations associated with the group, in addition to the group name, members, and various settings (e.g., notifications) for the relevant group.

[0069] The database 126 also stores augmentation data, such as overlays or filters, in an augmentation table 310. The augmentation data is associated with and applied to videos (for which data is stored in a video table 304) and images (for which data is stored in an image table 312).

[0070] The database 126 can also store data pertaining to individual and shared AR sessions. This data can include data communicated between an AR session client controller of a first client device 102 and another AR session client controller of a second client device 102, and data communicated between the AR session client controller and the augmentation system 208. Data can include data used to establish the common coordinate frame of the shared AR scene, the transformation between the devices, the session identifier, images depicting a body, skeletal joint positions, wrist joint positions, feet, and so forth.

[0071] Filters, in one example, are overlays that are displayed as overlaid on an image or video during presentation to a recipient user. Filters may be of various types, including user-selected filters from a set of filters presented to a sending user by the messaging client 104 when the sending user is composing a message. Other types of filters include geolocation filters (also known as geo-filters), which may be presented to a sending user based on geographic location. For example, geolocation filters specific to a neighborhood or special location may be presented within a user interface by the messaging client 104, based on geolocation information determined by a Global Positioning System (GPS) unit of the client device 102.

[0072] Another type of filter is a data filter, which may be selectively presented to a sending user by the messaging client 104, based on other inputs or information gathered by the client device 102 during the message creation process. Examples of data filters include current temperature at a specific location, a current speed at which a sending user is traveling, battery life for a client device 102, or the current time.

[0073] Other augmentation data that may be stored within the image table 312 includes augmented reality content items (e.g., corresponding to applying augmented reality experiences). An augmented reality content item or augmented reality item may be a real-time special effect and sound that may be added to an image or a video.

[0074] As described above, augmentation data includes augmented reality content items, overlays, image transformations, AR images, AR logos or emblems, and similar terms that refer to modifications that may be applied to image data (e.g., videos or images). This includes real-time modifications, which modify an image as it is captured using device sensors (e.g., one or multiple cameras) of a client device 102 and then displayed on a screen of the client device 102 with the modifications. This also includes modifications to stored content, such as video clips in a gallery that may be modified. For example, in a client device 102 with access to multiple augmented reality content items, a user can use a single video clip with multiple augmented reality content items to see how the different augmented reality content items will modify the stored clip. For example, multiple augmented reality content items that apply different pseudorandom movement models can be applied to the same content by selecting different augmented

reality content items for the content. Similarly, real-time video capture may be used with an illustrated modification to show how video images currently being captured by sensors of a client device 102 would modify the captured data. Such data may simply be displayed on the screen and not stored in memory, or the content captured by the device sensors may be recorded and stored in memory with or without the modifications (or both). In some systems, a preview feature can show how different augmented reality content items will look within different windows in a display at the same time. This can, for example, enable multiple windows with different pseudorandom animations to be viewed on a display at the same time.

[0075] Data and various systems using augmented reality content items or other such transform systems to modify content using this data can thus involve detection of real-world objects (e.g., faces, hands, bodies, cats, dogs, surfaces, objects, etc.), tracking of such objects as they leave, enter, and move around the field of view in video frames, and the modification or transformation of such objects as they are tracked. In various examples, different methods for achieving such transformations may be used. Some examples may involve generating a three-dimensional mesh model of the object or objects, and using transformations and animated textures of the model within the video to achieve the transformation. In other examples, tracking of points on an object may be used to place an image or texture (which may be two dimensional or three dimensional) at the tracked position. In still further examples, neural network analysis of video frames may be used to place images, models, or textures in content (e.g., images or frames of video). Augmented reality content items or elements thus refer both to the images, models, and textures used to create transformations in content, as well as to additional modeling and analysis information needed to achieve such transformations with object detection, tracking, and placement.

[0076] Real-time video processing can be performed with any kind of video data (e.g., video streams, video files, etc.) saved in a memory of a computerized system of any kind. For example, a user can load video files and save them in a memory of a device, or can generate a video stream using sensors of the device. Additionally, any objects can be processed using a computer animation model, such as a human's face and parts of a human body, animals, or non-living things such as chairs, cars, or other objects.

[0077] In some examples, when a particular modification is selected along with content to be transformed, elements to be transformed are identified by the computing device, and then detected and tracked if they are present in the frames of the video. The elements of the object are modified according to the request for modification, thus transforming the frames of the video stream. Transformation of frames of a video stream can be performed by different methods for different kinds of transformation. For example, for transformations of frames mostly referring to changing forms of an object's elements, characteristic points for each element of an object are calculated (e.g., using an Active Shape Model (ASM) or other known methods). Then, a mesh based on the characteristic points is generated for each of the at least one element of the object. This mesh is used in the following stage of tracking the elements of the object in the video stream. In the process of tracking, the mentioned mesh for each element is aligned with a position of each element. Then, additional points are generated on the mesh. A first set

of first points is generated for each element based on a request for modification, and a set of second points is generated for each element based on the set of first points and the request for modification. Then, the frames of the video stream can be transformed by modifying the elements of the object on the basis of the sets of first and second points and the mesh. In such method, a background of the modified object can be changed or distorted as well by tracking and modifying the background.

[0078] In some examples, transformations changing some areas of an object using its elements can be performed by calculating characteristic points for each element of an object and generating a mesh based on the calculated characteristic points. Points are generated on the mesh, and then various areas based on the points are generated. The elements of the object are then tracked by aligning the area for each element with a position for each of the at least one element, and properties of the areas can be modified based on the request for modification, thus transforming the frames of the video stream. Depending on the specific request for modification, properties of the mentioned areas can be transformed in different ways. Such modifications may involve changing color of areas; removing at least some part of areas from the frames of the video stream; including one or more new objects into areas which are based on a request for modification; and modifying or distorting the elements of an area or object. In various examples, any combination of such modifications or other similar modifications may be used. For certain models to be animated, some characteristic points can be selected as control points to be used in determining the entire state-space of options for the model animation.

[0079] In some examples, two meshes associated with different objects can be generated and deformed in correspondence to each other. A first mesh (also referred to as the body mesh) can be associated with and represent movements of a real-world object, such as a person, depicted in the image or video. A second mesh (also referred to as an external mesh) can be associated with an AR graphic or effect to be applied to the real-world object. The second mesh can be associated with placement information that specifies how the second mesh is placed or positioned in 3D space relative to the first mesh. The placement information can capture automatically generated correspondence information based on proximity (controlled by minimum or maximum distance thresholds or number of controlling vertices) between one or more vertices of the first mesh and one or more vertices of the second mesh. The placement information can also be specified in terms of UV space information that indicates how close or how far to place the second mesh in the UV space relative to UV coordinates of the first mesh. The placement information can also specify a first set of portions to deform based on movement of the corresponding first mesh and a second set of portions to deform based on an external force simulation model. As the first mesh is deformed in real time during capture of the image or video, the first and second sets of portions of the second mesh are similarly deformed (based on changes to the first mesh and/or outputs of the external force simulation model) to effectuate a change to the corresponding AR graphic that is rendered for display in the image or video.

[0080] In some examples of a computer animation model to transform image data using body/person detection, the body/person is detected on an image with use of a specific

body/person detection algorithm (e.g., 3D human pose estimation and mesh reconstruction processes). Then, an Active Shape Model (ASM) algorithm is applied to the body/person region of an image to detect body/person feature reference points.

[0081] Other methods and algorithms suitable for body/person detection can be used. For example, in some examples, features are located using a landmark, which represents a distinguishable point present in most of the images under consideration. For body/person landmarks, for example, the location of the left arm may be used. If an initial landmark is not identifiable, secondary landmarks may be used. Such landmark identification procedures may be used for any such objects. In some examples, a set of landmarks forms a shape. Shapes can be represented as vectors using the coordinates of the points in the shape. One shape is aligned to another with a similarity transform (allowing translation, scaling, and rotation) that minimizes the average Euclidean distance between shape points. The mean shape is the mean of the aligned training shapes.

[0082] In some examples, a search is started for landmarks from the mean shape aligned to the position and size of the body/person determined by a global body/person detector. Such a search then repeats the steps of suggesting a tentative shape by adjusting the locations of shape points by template matching of the image texture around each point and then conforming the tentative shape to a global shape model until convergence occurs. In some systems, individual template matches are unreliable, and the shape model pools the results of the weak template matches to form a stronger overall classifier. The entire search is repeated at each level in an image pyramid, from coarse to fine resolution.

[0083] A transformation system can capture an image or video stream on a client device (e.g., the client device 102) and perform complex image manipulations locally on the client device 102 while maintaining a suitable user experience, computation time, and power consumption. The complex image manipulations may include size and shape changes, emotion transfers (e.g., changing a face from a frown to a smile), state transfers (e.g., aging a subject, reducing apparent age, changing gender), style transfers, graphical element application, 3D human pose estimation, 3D body mesh reconstruction, and any other suitable image or video manipulation implemented by a convolutional neural network that has been configured to execute efficiently on the client device 102.

[0084] In some examples, a computer animation model to transform image data can be used by a system where a user may capture an image or video stream of the user (e.g., a selfie) using a client device 102 having a neural network operating as part of a messaging client 104 operating on the client device 102. The transformation system operating within the messaging client 104 determines the presence of a body/person within the image or video stream and provides modification icons associated with a computer animation model to transform image data, or the computer animation model can be present as associated with an interface described herein. The modification icons include changes that may be the basis for modifying the user's body/person within the image or video stream as part of the modification operation. Once a modification icon is selected, the transformation system initiates a process to convert the image of the user to reflect the selected modification icon (e.g., generate a smiling face on the user). A modified image or

video stream may be presented in a graphical user interface displayed on the client device 102 as soon as the image or video stream is captured, and a specified modification is selected. The transformation system may implement a complex convolutional neural network on a portion of the image or video stream to generate and apply the selected modification. That is, the user may capture the image or video stream and be presented with a modified result in real-time or near real-time once a modification icon has been selected. Further, the modification may be persistent while the video stream is being captured, and the selected modification icon remains toggled. Machine-taught neural networks may be used to enable such modifications.

[0085] The graphical user interface, presenting the modification performed by the transformation system, may supply the user with additional interaction options. Such options may be based on the interface used to initiate the content capture and selection of a particular computer animation model (e.g., initiation from a content creator user interface). In various examples, a modification may be persistent after an initial selection of a modification icon. The user may toggle the modification on or off by tapping or otherwise selecting the body/person being modified by the transformation system and store it for later viewing or browse to other areas of the imaging application. Where multiple faces are modified by the transformation system, the user may toggle the modification on or off globally by tapping or selecting a single body/person modified and displayed within a graphical user interface. In some examples, individual bodies/persons, among a group of multiple bodies/persons, may be individually modified, or such modifications may be individually toggled by tapping or selecting the individual body/person or a series of individual bodies/persons displayed within the graphical user interface.

[0086] A story table 314 stores data regarding collections of messages and associated image, video, or audio data, which are compiled into a collection (e.g., a story or a gallery). The creation of a particular collection may be initiated by a particular user (e.g., each user for which a record is maintained in the entity table 306). A user may create a "personal story" in the form of a collection of content that has been created and sent/broadcast by that user. To this end, the user interface of the messaging client 104 may include an icon that is user-selectable to enable a sending user to add specific content to his or her personal story.

[0087] A collection may also constitute a "live story," which is a collection of content from multiple users that is created manually, automatically, or using a combination of manual and automatic techniques. For example, a "live story" may constitute a curated stream of user-submitted content from various locations and events. Users whose client devices have location services enabled and are at a common location event at a particular time may, for example, be presented with an option, via a user interface of the messaging client 104, to contribute content to a particular live story. The live story may be identified to the user by the messaging client 104, based on his or her location. The end result is a "live story" told from a community perspective.

[0088] A further type of content collection is known as a "location story," which enables a user whose client device 102 is located within a specific geographic location (e.g., on a college or university campus) to contribute to a particular

collection. In some examples, a contribution to a location story may require a second degree of authentication to verify that the end user belongs to a specific organization or other entity (e.g., is a student on the university campus).

[0089] As mentioned above, the video table 304 stores video data that, in one example, is associated with messages for which records are maintained within the message table 302. Similarly, the image table 312 stores image data associated with messages for which message data is stored in the entity table 306. The entity table 306 may associate various augmentations from the augmentation table 310 with various images and videos stored in the image table 312 and the video table 304.

[0090] Trained machine learning technique(s) 307 stores parameters that have been trained during training of the external mesh deformation system 224. For example, trained machine learning techniques 307 stores the trained parameters of one or more neural network machine learning techniques.

Data Communications Architecture

[0091] FIG. 4 is a schematic diagram illustrating a structure of a message 400, according to some examples, generated by a messaging client 104 for communication to a further messaging client 104 or the messaging server 118. The content of a particular message 400 is used to populate the message table 302 stored within the database 126, accessible by the messaging server 118. Similarly, the content of a message 400 is stored in memory as “in-transit” or “in-flight” data of the client device 102 or the application servers 114. A message 400 is shown to include the following example components:

[0092] message identifier 402: a unique identifier that identifies the message 400.

[0093] message text payload 404: text, to be generated by a user via a user interface of the client device 102, and that is included in the message 400.

[0094] message image payload 406: image data, captured by a camera component of a client device 102 or retrieved from a memory component of a client device 102, and that is included in the message 400. Image data for a sent or received message 400 may be stored in the image table 312.

[0095] message video payload 408: video data, captured by a camera component or retrieved from a memory component of the client device 102, and that is included in the message 400. Video data for a sent or received message 400 may be stored in the video table 304.

[0096] message audio payload 410: audio data, captured by a microphone or retrieved from a memory component of the client device 102, and that is included in the message 400.

[0097] message augmentation data 412: augmentation data (e.g., filters, stickers, or other annotations or enhancements) that represents augmentations to be applied to message image payload 406, message video payload 408, or message audio payload 410 of the message 400. Augmentation data for a sent or received message 400 may be stored in the augmentation table 310.

[0098] message duration parameter 414: parameter value indicating, in seconds, the amount of time for which content of the message (e.g., the message image payload 406, message video payload 408, message

audio payload 410) is to be presented or made accessible to a user via the messaging client 104.

[0099] message geolocation parameter 416: geolocation data (e.g., latitudinal and longitudinal coordinates) associated with the content payload of the message. Multiple message geolocation parameter 416 values may be included in the payload, each of these parameter values being associated with respect to content items included in the content (e.g., a specific image within the message image payload 406, or a specific video in the message video payload 408).

[0100] message story identifier 418: identifier values identifying one or more content collections (e.g., “stories” identified in the story table 314) with which a particular content item in the message image payload 406 of the message 400 is associated. For example, multiple images within the message image payload 406 may each be associated with multiple content collections using identifier values.

[0101] message tag 420: each message 400 may be tagged with multiple tags, each of which is indicative of the subject matter of content included in the message payload. For example, where a particular image included in the message image payload 406 depicts an animal (e.g., a lion), a tag value may be included within the message tag 420 that is indicative of the relevant animal. Tag values may be generated manually, based on user input, or may be automatically generated using, for example, image recognition.

[0102] message sender identifier 422: an identifier (e.g., a messaging system identifier, email address, or device identifier) indicative of a user of the client device 102 on which the message 400 was generated and from which the message 400 was sent.

[0103] message receiver identifier 424: an identifier (e.g., a messaging system identifier, email address, or device identifier) indicative of a user of the client device 102 to which the message 400 is addressed.

[0104] The contents (e.g., values) of the various components of message 400 may be pointers to locations in tables within which content data values are stored. For example, an image value in the message image payload 406 may be a pointer to (or address of) a location within an image table 312. Similarly, values within the message video payload 408 may point to data stored within a video table 304, values stored within the message augmentation data 412 may point to data stored in an augmentation table 310, values stored within the message story identifier 418 may point to data stored in a story table 314, and values stored within the message sender identifier 422 and the message receiver identifier 424 may point to user records stored within an entity table 306.

External Mesh Deformation System

[0105] FIG. 5 is a block diagram showing an example external mesh deformation system 224, according to example examples. External mesh deformation system 224 includes a set of components 510 that operate on a set of input data (e.g., a monocular image depicting a real-world object, such as a person or training data). The set of input data is obtained from one or more database(s) (FIG. 3) during the training phases and is obtained from an RGB camera of a client device 102 when an AR/VR application is being used, such as by a messaging client 104. External

mesh deformation system **224** includes a machine learning technique module **512**, a skeletal key-points module **511**, a body mesh module **514**, an image modification module **518**, an AR effect module **519**, an external mesh module **530**, a blending parameter module **532**, a 3D body tracking module **513**, a whole-body segmentation module **515**, and an image display module **520**.

[0106] During training, the external mesh deformation system **224** receives a given training image or video from training data **501**. The external mesh deformation system **224** applies one or more machine learning techniques using the machine learning technique module **512** on the given training image or video. The machine learning technique module **512** extracts one or more features from the given training image or video to estimate a 3D body mesh of the person(s) or user(s) depicted in the image or video.

[0107] The machine learning technique module **512** retrieves 3D body mesh information associated with the given training image or video. The machine learning technique module **512** compares the estimated 3D body mesh with the ground truth garment 3D body mesh provided as part of the training data **502**. Based on a difference threshold or deviation of the comparison, the machine learning technique module **512** updates one or more coefficients or parameters and obtains one or more additional training images or videos. After a specified number of epochs or batches of training images have been processed and/or when the difference threshold or deviation reaches a specified value, the machine learning technique module **512** completes training and the parameters and coefficients of the machine learning technique module **512** are stored in the trained machine learning technique(s) **307**.

[0108] In some examples, during training, the machine learning technique module **512** receives 2D skeletal joint information from a skeletal key-points module **511**. The skeletal key-points module **511** tracks skeletal key points of a user depicted in a given training image (e.g., head joint, shoulder joints, hip joints, leg joints, and so forth) and provides the 2D or 3D coordinates of the skeletal key points. This information is used by the machine learning technique module **512** to identify distinguishing attributes of the user depicted in the training image and to generate the 3D body mesh.

[0109] The 3D body mesh generated by the machine learning technique module **512** is provided to the body mesh module **514**. The body mesh module **514** can track the object depicted in the image or video and update the 3D body mesh associated with the object. In an example, the body mesh module **514** can track the object based on 3D body tracking information provided by the 3D body tracking module **513**. The body mesh module **514** can update the 3D body mesh in 3D and can adjust a position, body type, rotation, or any other parameter of the 3D body mesh. FIG. 6 is a diagrammatic representation of outputs of the external mesh deformation system **224**, in accordance with some examples. Specifically, FIG. 6 shows a 3D body mesh **600** generated and tracked by the body mesh module **514**. In one example, the body mesh module **514** can track changes of the 3D body mesh across frames of the video. The body mesh module **514** can provide changes to the 3D body mesh to the external mesh module **530** to update and deform the external mesh based on changes to the 3D body mesh as the 3D body mesh is being blended into the external mesh.

[0110] In an example, the body mesh module **514** can determine a first set of coordinates of the 3D body mesh in a normal-tangent space for a first frame of the frames of the video and can determine a second set of coordinates of the 3D body mesh in the normal-tangent space for a second frame of the frames of the video. The body mesh module **514** can compute, in real time, a change between the first and second sets of coordinates in the normal-tangent space and can transfer the change between the first and second sets of coordinates in the normal-tangent space to the external mesh. Specifically, the external mesh module **530** can update and adjust a 3D position and a 3D orientation of the external mesh based on the change between the first and second sets of coordinates in the normal-tangent space. In this way, the external mesh module **530** can deform the external mesh associated with an AR graphic without using a rig or bone information of the real-world object.

[0111] In an example, the external mesh module **530** can compute a rate at which the first set of coordinates changes to the second set of coordinates in the normal-tangent space (or any other suitable space). The external mesh module **530** can deform the external mesh based on the rate at which the first set of coordinates changes to the second set of coordinates in the normal-tangent space (or any other suitable space). For example, if the person depicted in the image or video turns or twists at a particular rate or speed, the body mesh module **514** can compute a first rate that represents the direction and the speed at which the person turns or twists. This first rate is provided to the external mesh module **530** which then changes or deforms the external mesh based on the first rate.

[0112] The external mesh module **530** can receive an indication of an AR graphic from the AR effect module **519**. The AR effect module **519** can receive a user input that selects a given AR graphic (e.g., an AR bat) to add in real time to an underlying image or video. The external mesh module **530** can access a database and search the database for an external mesh associated with the given AR graphic. The external mesh module **530** can obtain placement information for the external mesh. The placement information can specify where to place the AR graphic in the image or video in relation to or relative to the real-world object, which portions of the AR graphic are deformed based on movement of the real-world object, and can specify a blending parameter for the external mesh. The blending parameter can include a linear or non-linear function that controls a rate indicating how quickly or slowly the real-world object portion is blended into the AR graphic or the AR bat. The AR graphic can also include information indicating which portions of the 3D body mesh to blend into the AR graphic and which portions to not change. For example, the AR graphic can specify that the head portion of the 3D body mesh is to be transformed into the head of the AR bat (head portion of the external mesh) without changing or affecting other portions of the 3D body mesh (e.g., the arms, legs, hands, and torso). In this way, the external mesh module **530** can communicate with the body mesh module **514** to modify the body mesh module to blend into the external mesh. Specifically, the 3D body mesh **600** can correspond to real-world person. In such cases, the image or video can be modified to depict the portion of the real-world person being changed into the AR element, such as by animating the body part of the person depicted in the video being morphed into the AR element. The morphing of the body part of the person can

take into account movement of the body part while the morphing takes place and pose information of the body part or person.

[0113] In one example, the placement information can specify an edge or body part of the 3D body mesh corresponding to the real-world graphic (e.g., a left arm, a right arm, a head, and so forth) that is attached to or overlaps the external mesh. The placement information can also specify a minimum distance between the edge or body part away from which an edge of the corresponding AR graphic (the external mesh) can be rendered for display. In response, the external mesh module 530 can maintain the position of the external mesh (and corresponding AR graphic) throughout a plurality of video frames at least the minimum distance away from the edge or body part of the body mesh. The position of the external mesh can be maintained relative to the 3D body mesh while the 3D body mesh is being blended or transformed into the external mesh.

[0114] In one example, the placement information can specify an edge or body part of the body mesh corresponding to the real-world graphic (e.g., a left arm, a right arm, a head, and so forth) that is attached to or overlaps the external mesh. The placement information can also specify a maximum distance between the edge or body part away from which an edge of the corresponding AR graphic (external mesh) can be rendered for display. In response, the external mesh module 530 can maintain the position of the external mesh (and corresponding AR graphic) throughout a plurality of video frames at most the maximum distance away from the edge or body part of the body mesh. In this way, the position of the external mesh can be maintained relative to the 3D body mesh while the 3D body mesh is being blended or transformed into the external mesh.

[0115] In one example, the placement information can specify an edge or body part of the body mesh corresponding to the real-world graphic (e.g., a left arm, a right arm, a head, and so forth) that is attached to the external mesh. The placement information can also specify a range of distances between the edge or body part away from which an edge of the corresponding AR graphic (external mesh) can be rendered for display. In response, the external mesh module 530 can maintain the position of the external mesh (and corresponding AR graphic) throughout a plurality of video frames between minimum and maximum values of the range of distances away from the edge or body part of the body mesh. In this way, the position of the external mesh can be maintained relative to the 3D body mesh while the 3D body mesh is being blended or transformed into the external mesh. The placement information can specify which body part, UV channel coordinates, voxels or other position information of the 3D body mesh to deform or blend into the external mesh. In such cases, the body mesh module 514 receives the placement information and can deform, blend, transform, or change the portions of the 3D body mesh that are specified into the external mesh.

[0116] In one example, the placement information can specify relative UV channel coordinates of the 3D body mesh that is to be transformed or blended into the external mesh. The relative UV channel coordinates can be used to maintain and place the external mesh (and corresponding AR graphic) within the image or video depicting an object and to identify which portions of the 3D body mesh to blend into the external mesh. In this case, the external mesh module 530 can obtain UV channel coordinates of the 3D

body mesh corresponding to the real-world object depicted in the image or video. The external mesh module 530 can also compute a set of UV channel coordinates of the external mesh based on the UV coordinates associated with the 3D body mesh and the relative UV channel coordinates in the placement information. For example, the placement information can specify a minimum or maximum distance away from a particular UV channel coordinate of the 3D body mesh at which the external mesh can be placed. In response, the external mesh module 530 can place the external mesh at a set of UV channel coordinates that are within the minimum or maximum distances from the UV coordinates of the 3D body mesh. In addition, the 3D body mesh portions within the minimum or maximum distances from the UV coordinates are blended or changed into the external mesh. As a result, the corresponding AR graphic associated with the external mesh can be used to blend, into the AR graphic, a portion of the real-world object depicted in the image or video at the position that corresponds to the set of UV coordinates. The portion of the real-world object can be blended or morphed into the AR graphic while the real-world object moves around the video, specifically based on movement information received from the body mesh module 514.

[0117] Based on the placement information and changes detected for the 3D body mesh, the external mesh module 530 can deform the external mesh in correspondence to the changes detected in the 3D body mesh. In one example, the external mesh can be deformed to change the position in 3D relative to the 3D body mesh in response to detecting a change in 3D position of the 3D body mesh while the 3D body mesh is being morphed or blended into the external mesh. For example, if the 3D body mesh is determined to move along a first axis by a first amount, the external mesh is similarly moved along the first axis by the first amount (or some other amount that is computed as a factor of the first amount) while some portion of the 3D body mesh is being morphed or blended into the external mesh. As another example, the external mesh can be rotated or twisted in a corresponding manner as the 3D body mesh. Specifically, if the 3D body mesh is determined to rotate along a rotational axis by a second amount, the external mesh is similarly rotated along the rotational axis by the second amount (or some other amount that is computed as a factor of the second amount) while some other portion of the 3D body mesh is being morphed or blended into the external mesh.

[0118] As another example, the external mesh can be deformed based on changes to the body shape, body state, or body properties across frames of the image or video. Specifically, if a portion of the 3D body mesh is reduced in size (e.g., a waist is indented by a specified amount as a result of an external force, such as a hand being placed on the waist), the corresponding portion of the external mesh is also reduced in size or repositioned in 3D space by the same amount or other specified amount. Such changes are also reflected in the morphing or blending of the 3D body model into the external mesh. In this way, if the resulting portion of the real-world object is being changed in real-time (e.g., as a result of the external force), the corresponding AR graphic into which the portion of the real-world object is also changed in a similar manner. In another example, the 3D body mesh can periodically expand and contract a chest portion of the 3D body mesh (or upper body portion) based on a breathing cycle of the person depicted in the image. In

such cases, the corresponding portion of the external mesh into which the 3D body mesh is blended, morphed, or transformed is also deformed to expand and contract in size in correspondence with the breathing cycle.

[0119] In an example, the body mesh module 514 can compute changes in the Normal-Tangent space of the corresponding object. Namely, the body mesh module 514 can determine movement of the 3D body mesh in the Normal-Tangent space and can provide indications of that movement to the external mesh module 530. The external mesh module 530 can apply changes to the external mesh based on the movement in the Normal-Tangent space. In this way, the 3D body mesh can be blended, morphed, changed, or transformed into the external mesh based on changes in the Normal-Tangent space of the corresponding object.

[0120] The blending parameter module 532 can control the rate at which the 3D body mesh portion corresponding to the external mesh is transformed, blended, or changed into the external mesh. For example, the blending parameter module 532 can control blending of the 3D body mesh portion into the external mesh according to a linear function. In such cases, the portion of the 3D body mesh is blended into the external mesh linearly in time. Specifically, the linear function can specify a maximum time interval used to effectuate the blending, such as 5 seconds. In such cases, the 3D body mesh portion is transformed into the external mesh at a rate that results in completion of the transformation after 5 seconds elapses.

[0121] In another example, the blending parameter module 532 can control blending of the 3D body mesh portion into the external mesh according to a non-linear function. In such cases, the portion of the 3D body mesh can be linearly blended into the external mesh at a first rate for a first portion of the given time interval to create a partially morphed 3D body mesh. After the first portion of the given time interval elapses, the partially morphed 3D body mesh continues to be blended into the external mesh at a second rate for a second portion of the given time interval. For example, a head portion of the 3D body mesh can be blended into a first portion of the external mesh at a first rate, such as to complete within a first time interval of 5 seconds. Then, a legs portion of the 3D body mesh can be blended into a second portion of the external mesh at a second rate, such as to complete within a second time interval of 2 seconds or 10 seconds. The second rate can be faster or slower than the first rate. In another example, the head portion of the 3D body mesh can be partially blended into the external mesh at the first rate so that the head portion does not completely blend into the external mesh at the end of the first time interval. Then after the first time interval elapses, the partially blended head portion can continue to be blended into the external mesh at a second faster or slower rate to completely blend into the external mesh. This can result in an effect in which the head of the real-world object slowly starts to turn into a head of an AR werewolf and then, after 5 seconds, the head of the real-world object continues turning into the AR werewolf head at a faster or slower pace.

[0122] In some examples, the body mesh module 514 communicates with the blending parameter module 532 to control the rate at which the portions of the 3D body mesh are morphed or blended into the external mesh that is being deformed by the external mesh module 530. For example, the blending parameter module 532 can compute a blending completion progress representing how much of the 3D body

mesh has been blended into the external mesh over a time period. The blending completion progress can be represented as a percentage of pixels or voxels within a specified region of the 3D body mesh that match the external mesh relative to pixels or voxels that match the 3D body mesh. As the number of pixels or voxels in the specified region of the 3D body mesh increase over time, the blending completion progress also increases. Blending is determined to be complete when a threshold number or percentage of pixels or voxels in the specified region of the 3D body mesh match the corresponding pixels or voxels of the external mesh.

[0123] For example, in response to determining that the blending completion progress is less than the threshold value (e.g., less than 50 percent of the pixels in a head portion of the 3D body mesh match a head portion of a werewolf external mesh), the portion of the 3D body mesh is linearly blended into the external mesh at a first rate to create a partially morphed 3D body mesh. The blending completion progress continues to be computed and measured, such as after the partially morphed 3D body mesh is completed. In an example, the blending completion progress can be determined to have reached the threshold value (e.g., more than 50 percent of the pixels in a head portion of the 3D body mesh match a head portion of a werewolf external mesh) and, in response, the first rate at which the partially morphed 3D body mesh continues to be blended into the external mesh is modified, such as increased or decreased. In some cases, the first rate is increased to cause the partially morphed 3D body mesh to continue to be blended into the external mesh at a faster pace than an initial pace. In some cases, the first rate is decreased to cause the partially morphed 3D body mesh to continue to be blended into the external mesh at a slower pace than an initial pace.

[0124] In an example, the blending parameter module 532 can compute a blending completion progress representing how much of the 3D body mesh has been blended into the external mesh over a time period. In response to determining that the blending completion progress is less than the threshold value (e.g., less than 50 percent of the pixels in a head portion of the 3D body mesh match a head portion of a werewolf external mesh), the portion of the 3D body mesh is linearly blended into the external mesh at a first rate to create a partially morphed 3D body mesh. The blending completion progress continues to be computed and measured, such as after the partially morphed 3D body mesh is completed. In an example, the blending completion progress can be determined to have reached the threshold value (e.g., more than 50 percent of the pixels in a head portion of the 3D body mesh match a head portion of a werewolf external mesh) and, in response, the partially morphed 3D body mesh continues to be blended into the external mesh according to a springing effect, such as to instantly be morphed into the external mesh. This way, a head portion of the 3D body mesh, for example, can start being blended slowly into a head portion of the external mesh over an initial period of time, such as 3 seconds. After the 3 seconds elapses, when the 3D body mesh portion is partially blended into the external mesh (but not completely), the remaining portion of the 3D body mesh is instantly bounded or morphed into the external mesh.

[0125] In an example, the AR effect module 519 selects and applies one or more AR elements or graphics to an object depicted in the image or video based on the body mesh associated with the object received from the body

mesh module **514**. This AR graphic combined with the real-world object depicted in the image or video is provided to the image modification module **518** to render an image or video that depicts the person wearing the AR object, such as an AR purse or earrings.

[0126] The image modification module **518** can adjust the image captured by the camera based on the AR effect selected by the AR effect module **519**. The image modification module **518** adjusts the way in which the AR garment (s) or fashion accessory placed over the user or person depicted in the image or video is/are presented in an image or video, such as by changing the physical properties (deformation) of the AR garment or fashion accessory based on the changes to the 3D body mesh of the user and an external force simulation and applying one or more AR elements (AR graphical elements). Image display module **520** combines the adjustments made by the image modification module **518** into the received monocular image or video depicting the user's body. The image or video is provided by the image display module **520** to the client device **102** and can then be sent to another user or stored for later access and display.

[0127] In some examples, the image modification module **518** can receive 3D body tracking information representing the 3D positions of the user depicted in the image from the 3D body tracking module **513**. The 3D body tracking module **513** generates the 3D body tracking information by processing the training data **501** using additional machine learning techniques. The image modification module **518** can also receive a whole-body segmentation representing which pixels in the image correspond to the whole body of the user from another machine learning technique. The whole-body segmentation can be received from the whole-body segmentation module **515**. The whole-body segmentation module **515** generates the whole-body segmentation by processing the training data **501** using a machine learning technique.

[0128] In one example, as shown in FIG. 7, the AR effect module **519** can apply one or more AR effects to an object depicted in an image or video **700** corresponding to a 3D body mesh **710** captured by a client device **102** using an external mesh **720**. The AR effect module **519** can receive input requesting to change or blend a portion of the object into the external mesh **720** or AR effect. The input can select which portion of the object to blend, the rate at which to blend the object, and/or can just identify an AR effect for which the rate and position of the object are automatically determined.

[0129] The external mesh **720** can include a portion that is attached to or overlaps the 3D body mesh **710**. In an example, the external mesh **720** can represent an AR animal, AR graphic, AR element, AR component, AR image, AR video, AR character, AR avatar, or other real-world object. For example, the external mesh module **530** can receive the 3D body mesh **710** and can also obtain the external mesh **720**, such as from a storage device, associated with an AR graphic **730** (e.g., an AR animal). The external mesh module **530** can obtain placement information **740** associated with the external mesh **720**. The placement information **740** can specify proximity parameters **742**, UV channel coordinates **744**, and/or blending parameter **746**. Based on the placement information **740**, the external mesh module **530** can specify where to place and position the external mesh **720** (and the corresponding AR graphic **730**) in the image or video **700** and which portions of the 3D body mesh **710** to blend or

morph into the external mesh **720**. Based on the placement information **740**, the external mesh module **530** can instruct the blending parameter module **532** on the rate and function used to control the transformation, blending, morphing, or changing of the 3D body mesh **710** into the external mesh **720**.

[0130] In an example, the external mesh module **530** can compute a correspondence **722** between the external mesh **720** and the 3D body mesh **710**. The correspondence can be used to deform the external mesh **720** in 3D along one or more axes **724** based on how the 3D body mesh **710** is deformed, as discussed above, while a portion of the 3D body mesh **710** is being morphed or blended into the external mesh **720**. As the external mesh module **530** deforms the external mesh **720**, the corresponding AR graphic **730** is similarly deformed and rendered for display within the image or video based on the placement information **740**. Namely, as the external mesh module **530** deforms the external mesh **720**, the corresponding AR graphic **730** into which the specified portion of the 3D body mesh is blended into is similarly deformed and rendered for display within the image or video based on the placement information **740**.

[0131] In one example, to generate the placement information **740**, an AR graphic designer can be provided on a client device **102** with a reference 3D body mesh. The AR graphic designer can drag and drop the external mesh, on the reference 3D body mesh, that the graphic designer creates in association with an AR graphic. The AR graphic designer can input relative placement parameters, such as proximity parameters and UV channel coordinates, or the client device **102** can automatically compute the placement parameters based on how close and how far different edges or pixels of the external mesh are with respect to different edges, pixels, or body parts of the 3D body mesh. Using this information, the placement information **740** is generated and stored in association with the AR graphic. In some cases, the placement information **740** is automatically created and presented to the AR designer. The AR designer can specify a range, a minimum value, or maximum value for each edge or one or more edges or pixels or voxels of the external mesh. These ranges, minimum values, or maximum values are used by the external mesh module **530** to control placement and positioning of the external mesh (and corresponding AR graphic) within an image or video based on the 3D body mesh of an object depicted in the image or video.

[0132] The AR graphic designer can also be provided a graphical user interface for inputting blending parameter information associated with the AR graphic **730**. Based on a selection of blending parameter function (e.g., linear or non-linear function), the client device **102** can include such function as the blending parameter **746**. The AR graphic designer can input custom blending parameter functions and/or can select a subset of blending parameter functions from a predetermined list to associate with the external mesh **720**. The AR graphic designer can select an initial blending rate at which a portion of the 3D body mesh **710** is blended into the external mesh **720** and one or more subsequent rates at which remaining portions of the 3D body mesh **710** are blended into the external mesh **720**. The blending parameter **746** input by the AR graphic designer can specify a sequence for blending portions of the 3D body mesh **710** into respective portions of the external mesh **720**. For example, the blending parameter **746** can specify that first a

head portion of the 3D body mesh **710** is to be blended into a head portion of the external mesh **720** at a particular rate. Then, when at least a threshold amount or when the head portion is completely blended into the head portion of the external mesh, the blending parameter **746** can specify that next a torso portion of the 3D body mesh **710** is to be blended into a torso portion of the external mesh **720** at the same rate or at a faster rate. Then, when at least a threshold amount or when the torso portion is completely blended into the torso portion of the external mesh, the blending parameter **746** can specify that next legs and arms portions of the 3D body mesh **710** are to be blended together into legs and arms portions of the external mesh **720** at the same rate or at a faster rate.

[0133] As shown in FIG. **8**, after the external mesh is deformed and used to transform or blend a portion of the 3D body mesh **710**, the corresponding AR graphic is rendered for display on the image or video. Specifically, the image or video **800** includes a depiction of the user or person. Initially, a first portion **801** of the user or person is blended into a first portion of an AR graphic **730** that has been deformed based on movement of the 3D body mesh **710**. A second portion **802** of the user or person is unchanged and is not blended into any portion of the AR graphic **730** while the first portion **801** is being blended. After a threshold period of time or after a threshold amount of the first portion **801** has been blended into the first portion of the AR graphic **730**, as shown in image or video **810**, a second portion **812** starts to be blended into the AR graphic **730**.

[0134] Namely, as shown in image or video **810**, the first portion **801** has been completely blended into the first portion **811** of the AR graphic **730** taking into account any movement or deformation of the user or person depicted in the image or video **800**. The deformation of the first portion **801** of the user or person is represented by change in pose or position of the hands of the person from the depiction shown in the image or video **800** to the depiction shown in the image or video **810**. The same pose or deformation of the first portion **801** is applied to the external mesh to cause the AR graphic **730** to also represent the same change in pose or position of the hands while the first portion **801** is being blended into the first portion **811** of the AR graphic **730**.

[0135] After the first portion **801** has been completely blended into the first portion **811** of the AR graphic **730**, the second portion **802** of the user or person begins to be blended into a second portion **812** of an AR graphic **730** that has been deformed based on movement of the 3D body mesh **710**. The deformation is represented by change in pose or position of the legs of the person from the depiction shown in image or video **800** to the depiction shown in the image or video **810**. The same pose or deformation is applied to the external mesh to cause the AR graphic **730** to also represent the same change in pose or position of the legs while the second portion **802** is being blended into the second portion **812** of the AR graphic **730**.

[0136] FIG. **9** is a flowchart of a process **900** performed by the external mesh deformation system **224**, in accordance with some examples. Although the flowchart can describe the operations as a sequential process, many of the operations can be performed in parallel or concurrently. In addition, the order of the operations may be re-arranged. A process is terminated when its operations are completed. A process may correspond to a method, a procedure, and the like. The steps of methods may be performed in whole or in

part, may be performed in conjunction with some or all of the steps in other methods, and may be performed by any number of different systems or any portion thereof, such as a processor included in any of the systems.

[0137] At operation **901**, the external mesh deformation system **224** (e.g., a client device **102** or a server) receives a video that includes a depiction of a real-world object, as discussed above.

[0138] At operation **902**, the external mesh deformation system **224** generates a three-dimensional (3D) body mesh associated with the real-world object that tracks movement of the real-world object across frames of the video, as discussed above.

[0139] At operation **903**, the external mesh deformation system **224** obtains an external mesh associated with an augmented reality (AR) element, as discussed above.

[0140] At operation **904**, the external mesh deformation system **224** automatically establishes a correspondence between a portion of the 3D body mesh associated with the real-world object and the external mesh, as discussed above.

[0141] At operation **905**, the external mesh deformation system **224** blends the portion of the 3D body mesh into the external mesh according to a blending parameter, as discussed above.

[0142] At operation **906**, as the portion of the 3D body mesh is being blended into the external mesh, the external mesh deformation system **224** modifies the video to depict a portion of the real-world object being changed into the AR element, as discussed above.

Machine Architecture

[0143] FIG. **10** is a diagrammatic representation of the machine **1000** within which instructions **1008** (e.g., software, a program, an application, an applet, an app, or other executable code) for causing the machine **1000** to perform any one or more of the methodologies discussed herein may be executed. For example, the instructions **1008** may cause the machine **1000** to execute any one or more of the methods described herein. The instructions **1008** transform the general, non-programmed machine **1000** into a particular machine **1000** programmed to carry out the described and illustrated functions in the manner described. The machine **1000** may operate as a standalone device or may be coupled (e.g., networked) to other machines. In a networked deployment, the machine **1000** may operate in the capacity of a server machine or a client machine in a server-client network environment, or as a peer machine in a peer-to-peer (or distributed) network environment. The machine **1000** may comprise, but not be limited to, a server computer, a client computer, a personal computer (PC), a tablet computer, a laptop computer, a netbook, a set-top box (STB), a personal digital assistant (PDA), an entertainment media system, a cellular telephone, a smartphone, a mobile device, a wearable device (e.g., a smartwatch), a smart home device (e.g., a smart appliance), other smart devices, a web appliance, a network router, a network switch, a network bridge, or any machine capable of executing the instructions **1008**, sequentially or otherwise, that specify actions to be taken by the machine **1000**. Further, while only a single machine **1000** is illustrated, the term “machine” shall also be taken to include a collection of machines that individually or jointly execute the instructions **1008** to perform any one or more of the methodologies discussed herein. The machine **1000**, for example, may comprise the client device **102** or any one of

a number of server devices forming part of the messaging server system **108**. In some examples, the machine **1000** may also comprise both client and server systems, with certain operations of a particular method or algorithm being performed on the server-side and with certain operations of the particular method or algorithm being performed on the client-side.

[0144] The machine **1000** may include processors **1002**, memory **1004**, and input/output (I/O) components **1038**, which may be configured to communicate with each other via a bus **1040**. In an example, the processors **1002** (e.g., a Central Processing Unit (CPU), a Reduced Instruction Set Computing (RISC) Processor, a Complex Instruction Set Computing (CISC) Processor, a Graphics Processing Unit (GPU), a Digital Signal Processor (DSP), an Application Specific Integrated Circuit (ASIC), a Radio-Frequency Integrated Circuit (RFIC), another processor, or any suitable combination thereof) may include, for example, a processor **1006** and a processor **1010** that execute the instructions **1008**. The term “processor” is intended to include multi-core processors that may comprise two or more independent processors (sometimes referred to as “cores”) that may execute instructions contemporaneously. Although FIG. **10** shows multiple processors **1002**, the machine **1000** may include a single processor with a single-core, a single processor with multiple cores (e.g., a multi-core processor), multiple processors with a single core, multiple processors with multiples cores, or any combination thereof.

[0145] The memory **1004** includes a main memory **1012**, a static memory **1014**, and a storage unit **1016**, all accessible to the processors **1002** via the bus **1040**. The main memory **1004**, the static memory **1014**, and the storage unit **1016** store the instructions **1008** embodying any one or more of the methodologies or functions described herein. The instructions **1008** may also reside, completely or partially, within the main memory **1012**, within the static memory **1014**, within machine-readable medium within the storage unit **1016**, within at least one of the processors **1002** (e.g., within the processor’s cache memory), or any suitable combination thereof, during execution thereof by the machine **1000**.

[0146] The I/O components **1038** may include a wide variety of components to receive input, provide output, produce output, transmit information, exchange information, capture measurements, and so on. The specific I/O components **1038** that are included in a particular machine will depend on the type of machine. For example, portable machines such as mobile phones may include a touch input device or other such input mechanisms, while a headless server machine will likely not include such a touch input device. It will be appreciated that the I/O components **1038** may include many other components that are not shown in FIG. **10**. In various examples, the I/O components **1038** may include user output components **1024** and user input components **1026**. The user output components **1024** may include visual components (e.g., a display such as a plasma display panel (PDP), a light-emitting diode (LED) display, a liquid crystal display (LCD), a projector, or a cathode ray tube (CRT)), acoustic components (e.g., speakers), haptic components (e.g., a vibratory motor, resistance mechanisms), other signal generators, and so forth. The user input components **1026** may include alphanumeric input components (e.g., a keyboard, a touch screen configured to receive alphanumeric input, a photo-optical keyboard, or other

alphanumeric input components), point-based input components (e.g., a mouse, a touchpad, a trackball, a joystick, a motion sensor, or another pointing instrument), tactile input components (e.g., a physical button, a touch screen that provides location and force of touches or touch gestures, or other tactile input components), audio input components (e.g., a microphone), and the like.

[0147] In further examples, the I/O components **1038** may include biometric components **1028**, motion components **1030**, environmental components **1032**, or position components **1034**, among a wide array of other components. For example, the biometric components **1028** include components to detect expressions (e.g., hand expressions, facial expressions, vocal expressions, body gestures, or eye-tracking), measure biosignals (e.g., blood pressure, heart rate, body temperature, perspiration, or brain waves), identify a person (e.g., voice identification, retinal identification, facial identification, fingerprint identification, or electroencephalogram-based identification), and the like. The motion components **1030** include acceleration sensor components (e.g., accelerometer), gravitation sensor components, rotation sensor components (e.g., gyroscope).

[0148] The environmental components **1032** include, for example, one or more cameras (with still image/photograph and video capabilities), illumination sensor components (e.g., photometer), temperature sensor components (e.g., one or more thermometers that detect ambient temperature), humidity sensor components, pressure sensor components (e.g., barometer), acoustic sensor components (e.g., one or more microphones that detect background noise), proximity sensor components (e.g., infrared sensors that detect nearby objects), gas sensors (e.g., gas detection sensors to detection concentrations of hazardous gases for safety or to measure pollutants in the atmosphere), or other components that may provide indications, measurements, or signals corresponding to a surrounding physical environment.

[0149] With respect to cameras, the client device **102** may have a camera system comprising, for example, front cameras on a front surface of the client device **102** and rear cameras on a rear surface of the client device **102**. The front cameras may, for example, be used to capture still images and video of a user of the client device **102** (e.g., “selfies”), which may then be augmented with augmentation data (e.g., filters) described above. The rear cameras may, for example, be used to capture still images and videos in a more traditional camera mode, with these images similarly being augmented with augmentation data. In addition to front and rear cameras, the client device **102** may also include a 360° camera for capturing 360° photographs and videos.

[0150] Further, the camera system of a client device **102** may include dual rear cameras (e.g., a primary camera as well as a depth-sensing camera), or even triple, quad or penta rear camera configurations on the front and rear sides of the client device **102**. These multiple cameras systems may include a wide camera, an ultra-wide camera, a telephoto camera, a macro camera, and a depth sensor, for example.

[0151] The position components **1034** include location sensor components (e.g., a GPS receiver component), altitude sensor components (e.g., altimeters or barometers that detect air pressure from which altitude may be derived), orientation sensor components (e.g., magnetometers), and the like.

[0152] Communication may be implemented using a wide variety of technologies. The I/O components 1038 further include communication components 1036 operable to couple the machine 1000 to a network 1020 or devices 1022 via respective coupling or connections. For example, the communication components 1036 may include a network interface component or another suitable device to interface with the network 1020. In further examples, the communication components 1036 may include wired communication components, wireless communication components, cellular communication components, Near Field Communication (NFC) components, Bluetooth® components (e.g., Bluetooth® Low Energy), WiFi® components, and other communication components to provide communication via other modalities. The devices 1022 may be another machine or any of a wide variety of peripheral devices (e.g., a peripheral device coupled via a USB).

[0153] Moreover, the communication components 1036 may detect identifiers or include components operable to detect identifiers. For example, the communication components 1036 may include Radio Frequency Identification (RFID) tag reader components, NFC smart tag detection components, optical reader components (e.g., an optical sensor to detect one-dimensional bar codes such as Universal Product Code (UPC) bar code, multi-dimensional bar codes such as Quick Response (QR) code, Aztec code, Data Matrix, Dataglyph, MaxiCode, PDF417, Ultra Code, UCC RSS-2D bar code, and other optical codes), or acoustic detection components (e.g., microphones to identify tagged audio signals). In addition, a variety of information may be derived via the communication components 1036, such as location via Internet Protocol (IP) geolocation, location via Wi-Fi® signal triangulation, location via detecting an NFC beacon signal that may indicate a particular location, and so forth.

[0154] The various memories (e.g., main memory 1012, static memory 1014, and memory of the processors 1002) and storage unit 1016 may store one or more sets of instructions and data structures (e.g., software) embodying or used by any one or more of the methodologies or functions described herein. These instructions (e.g., the instructions 1008), when executed by processors 1002, cause various operations to implement the disclosed examples.

[0155] The instructions 1008 may be transmitted or received over the network 1020, using a transmission medium, via a network interface device (e.g., a network interface component included in the communication components 1036) and using any one of several well-known transfer protocols (e.g., hypertext transfer protocol (HTTP)). Similarly, the instructions 1008 may be transmitted or received using a transmission medium via a coupling (e.g., a peer-to-peer coupling) to the devices 1022.

Software Architecture

[0156] FIG. 11 is a block diagram 1100 illustrating a software architecture 1104, which can be installed on any one or more of the devices described herein. The software architecture 1104 is supported by hardware such as a machine 1102 that includes processors 1120, memory 1126, and I/O components 1138. In this example, the software architecture 1104 can be conceptualized as a stack of layers, where each layer provides a particular functionality. The software architecture 1104 includes layers such as an oper-

ating system 1112, libraries 1110, frameworks 1108, and applications 1106. Operationally, the applications 1106 invoke API calls 1150 through the software stack and receive messages 1152 in response to the API calls 1150.

[0157] The operating system 1112 manages hardware resources and provides common services. The operating system 1112 includes, for example, a kernel 1114, services 1116, and drivers 1122. The kernel 1114 acts as an abstraction layer between the hardware and the other software layers. For example, the kernel 1114 provides memory management, processor management (e.g., scheduling), component management, networking, and security settings, among other functionality. The services 1116 can provide other common services for the other software layers. The drivers 1122 are responsible for controlling or interfacing with the underlying hardware. For instance, the drivers 1122 can include display drivers, camera drivers, BLUETOOTH® or BLUETOOTH® Low Energy drivers, flash memory drivers, serial communication drivers (e.g., USB drivers), WI-FI® drivers, audio drivers, power management drivers, and so forth.

[0158] The libraries 1110 provide a common low-level infrastructure used by applications 1106. The libraries 1110 can include system libraries 1118 (e.g., C standard library) that provide functions such as memory allocation functions, string manipulation functions, mathematic functions, and the like. In addition, the libraries 1110 can include API libraries 1124 such as media libraries (e.g., libraries to support presentation and manipulation of various media formats such as Moving Picture Experts Group-4 (MPEG4), Advanced Video Coding (H.264 or AVC), Moving Picture Experts Group Layer-3 (MP3), Advanced Audio Coding (AAC), Adaptive Multi-Rate (AMR) audio codec, Joint Photographic Experts Group (JPEG or JPG), or Portable Network Graphics (PNG)), graphics libraries (e.g., an OpenGL framework used to render in two dimensions (2D) and three dimensions (3D) in a graphic content on a display), database libraries (e.g., SQLite to provide various relational database functions), web libraries (e.g., WebKit to provide web browsing functionality), and the like. The libraries 1110 can also include a wide variety of other libraries 1128 to provide many other APIs to the applications 1106.

[0159] The frameworks 1108 provide a common high-level infrastructure that is used by the applications 1106. For example, the frameworks 1108 provide various graphical user interface (GUI) functions, high-level resource management, and high-level location services. The frameworks 1108 can provide a broad spectrum of other APIs that can be used by the applications 1106, some of which may be specific to a particular operating system or platform.

[0160] In an example, the applications 1106 may include a home application 1136, a contacts application 1130, a browser application 1132, a book reader application 1134, a location application 1142, a media application 1144, a messaging application 1146, a game application 1148, and a broad assortment of other applications such as a external application 1140. The applications 1106 are programs that execute functions defined in the programs. Various programming languages can be employed to create one or more of the applications 1106, structured in a variety of manners, such as object-oriented programming languages (e.g., Objective-C, Java, or C++) or procedural programming languages (e.g., C or assembly language). In a specific example, the external application 1140 (e.g., an application

developed using the ANDROID™ or IOS™ software development kit (SDK) by an entity other than the vendor of the particular platform) may be mobile software running on a mobile operating system such as IOS™, ANDROID™, WINDOWS® Phone, or another mobile operating system. In this example, the external application 1140 can invoke the API calls 1150 provided by the operating system 1112 to facilitate functionality described herein.

Glossary

[0161] “Carrier signal” refers to any intangible medium that is capable of storing, encoding, or carrying instructions for execution by the machine, and includes digital or analog communications signals or other intangible media to facilitate communication of such instructions. Instructions may be transmitted or received over a network using a transmission medium via a network interface device.

[0162] “Client device” refers to any machine that interfaces to a communications network to obtain resources from one or more server systems or other client devices. A client device may be, but is not limited to, a mobile phone, desktop computer, laptop, portable digital assistants (PDAs), smartphones, tablets, ultrabooks, netbooks, laptops, multi-processor systems, microprocessor-based or programmable consumer electronics, game consoles, set-top boxes, or any other communication device that a user may use to access a network.

[0163] “Communication network” refers to one or more portions of a network that may be an ad hoc network, an intranet, an extranet, a virtual private network (VPN), a local area network (LAN), a wireless LAN (WLAN), a wide area network (WAN), a wireless WAN (WWAN), a metropolitan area network (MAN), the Internet, a portion of the Internet, a portion of the Public Switched Telephone Network (PSTN), a plain old telephone service (POTS) network, a cellular telephone network, a wireless network, a Wi-Fi® network, another type of network, or a combination of two or more such networks. For example, a network or a portion of a network may include a wireless or cellular network and the coupling may be a Code Division Multiple Access (CDMA) connection, a Global System for Mobile communications (GSM) connection, or other types of cellular or wireless coupling. In this example, the coupling may implement any of a variety of types of data transfer technology, such as Single Carrier Radio Transmission Technology (1×RTT), Evolution-Data Optimized (EVDO) technology, General Packet Radio Service (GPRS) technology, Enhanced Data rates for GSM Evolution (EDGE) technology, third Generation Partnership Project (3GPP) including 3G, fourth generation wireless (4G) networks, Universal Mobile Telecommunications System (UMTS), High Speed Packet Access (HSPA), Worldwide Interoperability for Microwave Access (WiMAX), Long Term Evolution (LTE) standard, others defined by various standard-setting organizations, other long-range protocols, or other data transfer technology.

[0164] “Component” refers to a device, physical entity, or logic having boundaries defined by function or subroutine calls, branch points, APIs, or other technologies that provide for the partitioning or modularization of particular processing or control functions. Components may be combined via their interfaces with other components to carry out a machine process. A component may be a packaged func-

tional hardware unit designed for use with other components and a part of a program that usually performs a particular function of related functions.

[0165] Components may constitute either software components (e.g., code embodied on a machine-readable medium) or hardware components. A “hardware component” is a tangible unit capable of performing certain operations and may be configured or arranged in a certain physical manner. In various examples, one or more computer systems (e.g., a standalone computer system, a client computer system, or a server computer system) or one or more hardware components of a computer system (e.g., a processor or a group of processors) may be configured by software (e.g., an application or application portion) as a hardware component that operates to perform certain operations as described herein.

[0166] A hardware component may also be implemented mechanically, electronically, or any suitable combination thereof. For example, a hardware component may include dedicated circuitry or logic that is permanently configured to perform certain operations. A hardware component may be a special-purpose processor, such as a field-programmable gate array (FPGA) or an application specific integrated circuit (ASIC). A hardware component may also include programmable logic or circuitry that is temporarily configured by software to perform certain operations. For example, a hardware component may include software executed by a general-purpose processor or other programmable processor. Once configured by such software, hardware components become specific machines (or specific components of a machine) uniquely tailored to perform the configured functions and are no longer general-purpose processors. It will be appreciated that the decision to implement a hardware component mechanically, in dedicated and permanently configured circuitry, or in temporarily configured circuitry (e.g., configured by software), may be driven by cost and time considerations. Accordingly, the phrase “hardware component” (or “hardware-implemented component”) should be understood to encompass a tangible entity, be that an entity that is physically constructed, permanently configured (e.g., hardwired), or temporarily configured (e.g., programmed) to operate in a certain manner or to perform certain operations described herein.

[0167] Considering examples in which hardware components are temporarily configured (e.g., programmed), each of the hardware components need not be configured or instantiated at any one instance in time. For example, where a hardware component comprises a general-purpose processor configured by software to become a special-purpose processor, the general-purpose processor may be configured as respectively different special-purpose processors (e.g., comprising different hardware components) at different times. Software accordingly configures a particular processor or processors, for example, to constitute a particular hardware component at one instance of time and to constitute a different hardware component at a different instance of time.

[0168] Hardware components can provide information to, and receive information from, other hardware components. Accordingly, the described hardware components may be regarded as being communicatively coupled. Where multiple hardware components exist contemporaneously, communications may be achieved through signal transmission (e.g., over appropriate circuits and buses) between or among

two or more of the hardware components. In examples in which multiple hardware components are configured or instantiated at different times, communications between such hardware components may be achieved, for example, through the storage and retrieval of information in memory structures to which the multiple hardware components have access. For example, one hardware component may perform an operation and store the output of that operation in a memory device to which it is communicatively coupled. A further hardware component may then, at a later time, access the memory device to retrieve and process the stored output. Hardware components may also initiate communications with input or output devices, and can operate on a resource (e.g., a collection of information).

[0169] The various operations of example methods described herein may be performed, at least partially, by one or more processors that are temporarily configured (e.g., by software) or permanently configured to perform the relevant operations. Whether temporarily or permanently configured, such processors may constitute processor-implemented components that operate to perform one or more operations or functions described herein. As used herein, “processor-implemented component” refers to a hardware component implemented using one or more processors. Similarly, the methods described herein may be at least partially processor-implemented, with a particular processor or processors being an example of hardware. For example, at least some of the operations of a method may be performed by one or more processors **1002** or processor-implemented components. Moreover, the one or more processors **1002** may also operate to support performance of the relevant operations in a “cloud computing” environment or as a “software as a service” (SaaS). For example, at least some of the operations may be performed by a group of computers (as examples of machines including processors), with these operations being accessible via a network (e.g., the Internet) and via one or more appropriate interfaces (e.g., an API). The performance of certain of the operations may be distributed among the processors, not only residing within a single machine, but deployed across a number of machines. In some examples, the processors or processor-implemented components may be located in a single geographic location (e.g., within a home environment, an office environment, or a server farm). In other examples, the processors or processor-implemented components may be distributed across a number of geographic locations.

[0170] “Computer-readable storage medium” refers to both machine-storage media and transmission media. Thus, the terms include both storage devices/media and carrier waves/modulated data signals. The terms “machine-readable medium,” “computer-readable medium” and “device-readable medium” mean the same thing and may be used interchangeably in this disclosure.

[0171] “Ephemeral message” refers to a message that is accessible for a time-limited duration. An ephemeral message may be a text, an image, a video and the like. The access time for the ephemeral message may be set by the message sender. Alternatively, the access time may be a default setting or a setting specified by the recipient. Regardless of the setting technique, the message is transitory.

[0172] “Machine storage medium” refers to a single or multiple storage devices and media (e.g., a centralized or distributed database, and associated caches and servers) that store executable instructions, routines and data. The term

shall accordingly be taken to include, but not be limited to, solid-state memories, and optical and magnetic media, including memory internal or external to processors. Specific examples of machine-storage media, computer-storage media and device-storage media include non-volatile memory, including by way of example semiconductor memory devices, e.g., erasable programmable read-only memory (EPROM), electrically erasable programmable read-only memory (EEPROM), FPGA, and flash memory devices; magnetic disks such as internal hard disks and removable disks; magneto-optical disks; and CD-ROM and DVD-ROM disks. The terms “machine-storage medium,” “device-storage medium,” “computer-storage medium” mean the same thing and may be used interchangeably in this disclosure. The terms “machine-storage media,” “computer-storage media,” and “device-storage media” specifically exclude carrier waves, modulated data signals, and other such media, at least some of which are covered under the term “signal medium.”

[0173] “Non-transitory computer-readable storage medium” refers to a tangible medium that is capable of storing, encoding, or carrying the instructions for execution by a machine.

[0174] “Signal medium” refers to any intangible medium that is capable of storing, encoding, or carrying the instructions for execution by a machine and includes digital or analog communications signals or other intangible media to facilitate communication of software or data. The term “signal medium” shall be taken to include any form of a modulated data signal, carrier wave, and so forth. The term “modulated data signal” means a signal that has one or more of its characteristics set or changed in such a manner as to encode information in the signal. The terms “transmission medium” and “signal medium” mean the same thing and may be used interchangeably in this disclosure.

[0175] Changes and modifications may be made to the disclosed examples without departing from the scope of the present disclosure. These and other changes or modifications are intended to be included within the scope of the present disclosure, as expressed in the following claims.

What is claimed is:

1. A method comprising:

generating a three-dimensional (3D) mesh associated with a real-world object;
 obtaining an external mesh associated with an augmented reality (AR) element;
 automatically establishing a correspondence between a portion of the 3D mesh associated with the real-world object and the external mesh;
 receiving placement information for the external mesh from a third-party designer of the external mesh;
 adding the external mesh to the 3D mesh based on the placement information;
 blending the portion of the 3D mesh into the external mesh according to a blending parameter; and
 as the portion of the 3D mesh is being blended into the external mesh, modifying an image to depict a portion of the real-world object being changed into the AR element.

2. The method of claim 1, further comprising:

receiving, by one or more processors of a client device, the video that includes a depiction of the real-world object, wherein the 3D mesh tracks movement of the real-world object across frames of a video; and

- blending the portion of the 3D mesh using a function selected from a group consisting of a linear function and non-linear function that controls progression of blending the portion of the 3D mesh into the external mesh over time.
- 3.** The method of claim **1**, wherein the real-world object comprises a person, wherein the portion of the 3D mesh represents a body part of the person depicted in the image, and wherein modifying the image to depict the portion of the real-world object being changed into the AR element comprises animating the body part of the person depicted in the image being morphed into the AR element.
- 4.** The method of claim **1**, further comprising deforming the external mesh based on movement information of the 3D mesh and based on a pose of the real-world object.
- 5.** The method of claim **4**, wherein the portion of the 3D mesh is blended into the external mesh as the external mesh is being deformed based on the movement information of the 3D mesh such that the image is modified in real time to depict the portion of the real-world object being changed into the AR element while the real-world object moves around a depicted real-world environment.
- 6.** The method of claim **1**, further comprising animating the blending of the portion of the 3D mesh into the external mesh according to a selected function.
- 7.** The method of claim **6**, wherein the blending is performed over a given time interval, further comprising:
linearly blending the portion of the 3D mesh into the external mesh at a first rate for a first portion of the given time interval to create a partially morphed 3D mesh; and
after the first portion of the given time interval elapses, continuing to blend the partially morphed 3D mesh into the external mesh at a second rate for a second portion of the given time interval.
- 8.** The method of claim **6**, wherein the blending further comprises:
computing blending completion progress representing how much of the 3D mesh has been blended into the external mesh over a time period;
determining that the blending completion progress is less than a threshold value; and
in response to determining that the blending completion progress is less than the threshold value, linearly blending the portion of the 3D mesh into the external mesh at a first rate to create a partially morphed 3D mesh.
- 9.** The method of claim **8**, further comprising:
determining that the blending completion progress has reached the threshold value as the portion of the 3D mesh is blended into the external mesh at the first rate; and
in response to determining that the blending completion progress has reached the threshold value, modifying the first rate at which the partially morphed 3D mesh continues to be blended into the external mesh.
- 10.** The method of claim **9**, further comprising increasing the first rate to cause the partially morphed 3D mesh to continue to be blended into the external mesh at a faster pace.
- 11.** The method of claim **9**, further comprising decreasing the first rate to cause the partially morphed 3D mesh to continue to be blended into the external mesh at a slower pace.
- 12.** The method of claim **8**, further comprising:
determining that the blending completion progress has reached the threshold value as the portion of the 3D mesh is blended into the external mesh at the first rate; and
in response to determining that the blending completion progress has reached the threshold value, causing the partially morphed 3D mesh to be blended into the external mesh according to a springing effect.
- 13.** The method of claim **1**, further comprising:
computing a change in body shape, body state, or body properties of the real-world object across frames of a video; and
adjusting a shape of the external mesh based on the change in the shape, body state, or body properties.
- 14.** The method of claim **1**, further comprising:
computing a change in position or scale of the real-world object across frames of a video; and
adjusting a position or scale of the external mesh based on the change in the position or scale.
- 15.** The method of claim **1**, further comprising:
computing a change in rotation of the real-world object across frames of a video; and
rotating the external mesh in 3D based on the change in the rotation.
- 16.** The method of claim **1**, further comprising:
determining a first set of coordinates of the 3D mesh in a normal-tangent space for a first frame of frames of a video; and
determining a second set of coordinates of the 3D mesh in the normal-tangent space for a second frame of the frames of the video.
- 17.** The method of claim **16**, further comprising:
computing, in real time, a change between the first and second sets of coordinates in the normal-tangent space.
- 18.** The method of claim **17**, further comprising:
transferring the change between the first and second sets of coordinates in the normal-tangent space to the external mesh as the 3D mesh continues to be blended into the external mesh.
- 19.** A system comprising:
a processor of a client device; and
a memory component having instructions stored thereon that, when executed by the processor, cause the processor to perform operations comprising:
generating a three-dimensional (3D) mesh associated with a real-world object;
obtaining an external mesh associated with an augmented reality (AR) element;
automatically establishing a correspondence between a portion of the 3D mesh associated with the real-world object and the external mesh;
receiving placement information for the external mesh from a third-party designer of the external mesh;
adding the external mesh to the 3D mesh based on the placement information;
blending the portion of the 3D mesh into the external mesh according to a blending parameter; and
as the portion of the 3D mesh is being blended into the external mesh, modifying an image to depict a portion of the real-world object being changed into the AR element.

20. A non-transitory computer-readable storage medium having stored thereon instructions that, when executed by a processor of a client device, cause the processor to perform operations comprising:

- generating a three-dimensional (3D) mesh associated with a real-world object;
- obtaining an external mesh associated with an augmented reality (AR) element;
- automatically establishing a correspondence between a portion of the 3D mesh associated with the real-world object and the external mesh;
- receiving placement information for the external mesh from a third-party designer of the external mesh;
- adding the external mesh to the 3D mesh based on the placement information;
- blending the portion of the 3D mesh into the external mesh according to a blending parameter; and
- as the portion of the 3D mesh is being blended into the external mesh, modifying an image to depict a portion of the real-world object being changed into the AR element.

* * * * *