



US 20230417567A1

(19) **United States**

(12) **Patent Application Publication**
Waldman

(10) **Pub. No.: US 2023/0417567 A1**

(43) **Pub. Date: Dec. 28, 2023**

(54) **AUGMENTED REALITY MAPS**

Publication Classification

(71) Applicant: **Apple Inc.**, Cupertino, CA (US)

(51) **Int. Cl.**
G01C 21/36 (2006.01)

(72) Inventor: **Jaron Waldman**, Palo Alto, CA (US)

H04N 23/63 (2006.01)

(73) Assignee: **Apple Inc.**, Cupertino, CA (US)

G06T 11/60 (2006.01)

H04N 7/18 (2006.01)

(21) Appl. No.: **18/216,880**

(52) **U.S. Cl.**
CPC **G01C 21/3647** (2013.01); **G01C 21/3602** (2013.01); **G01C 21/3679** (2013.01); **H04N 23/633** (2023.01); **G01C 21/3682** (2013.01); **G06T 11/60** (2013.01); **H04N 7/185** (2013.01)

(22) Filed: **Jun. 30, 2023**

(57) **ABSTRACT**

Related U.S. Application Data

(63) Continuation of application No. 17/000,861, filed on Aug. 24, 2020, now Pat. No. 11,692,842, which is a continuation of application No. 15/341,915, filed on Nov. 2, 2016, now Pat. No. 10,760,922, which is a continuation of application No. 12/705,558, filed on Feb. 12, 2010, now Pat. No. 9,488,488.

A handheld communication device can capture and display a real-time video stream. The handheld communication device detects a geographic position and camera direction of the handheld communication device. A route is identified from the geographic position of the handheld communication device to a point of interest. The captured video stream is visually augmented with an indicator indicating a direction to travel to the point of interest. The indicator is overlaid on the captured real-time video stream.

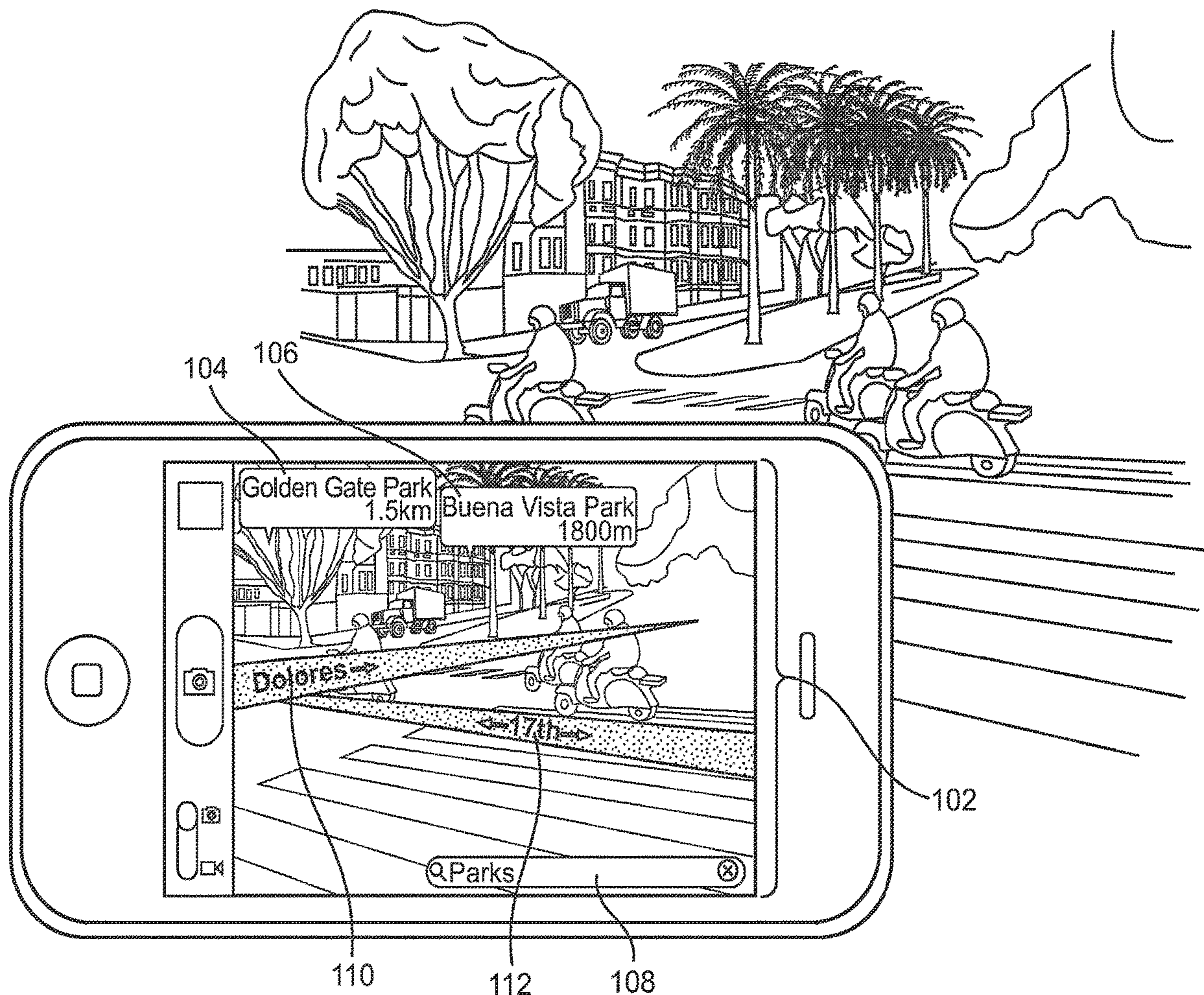

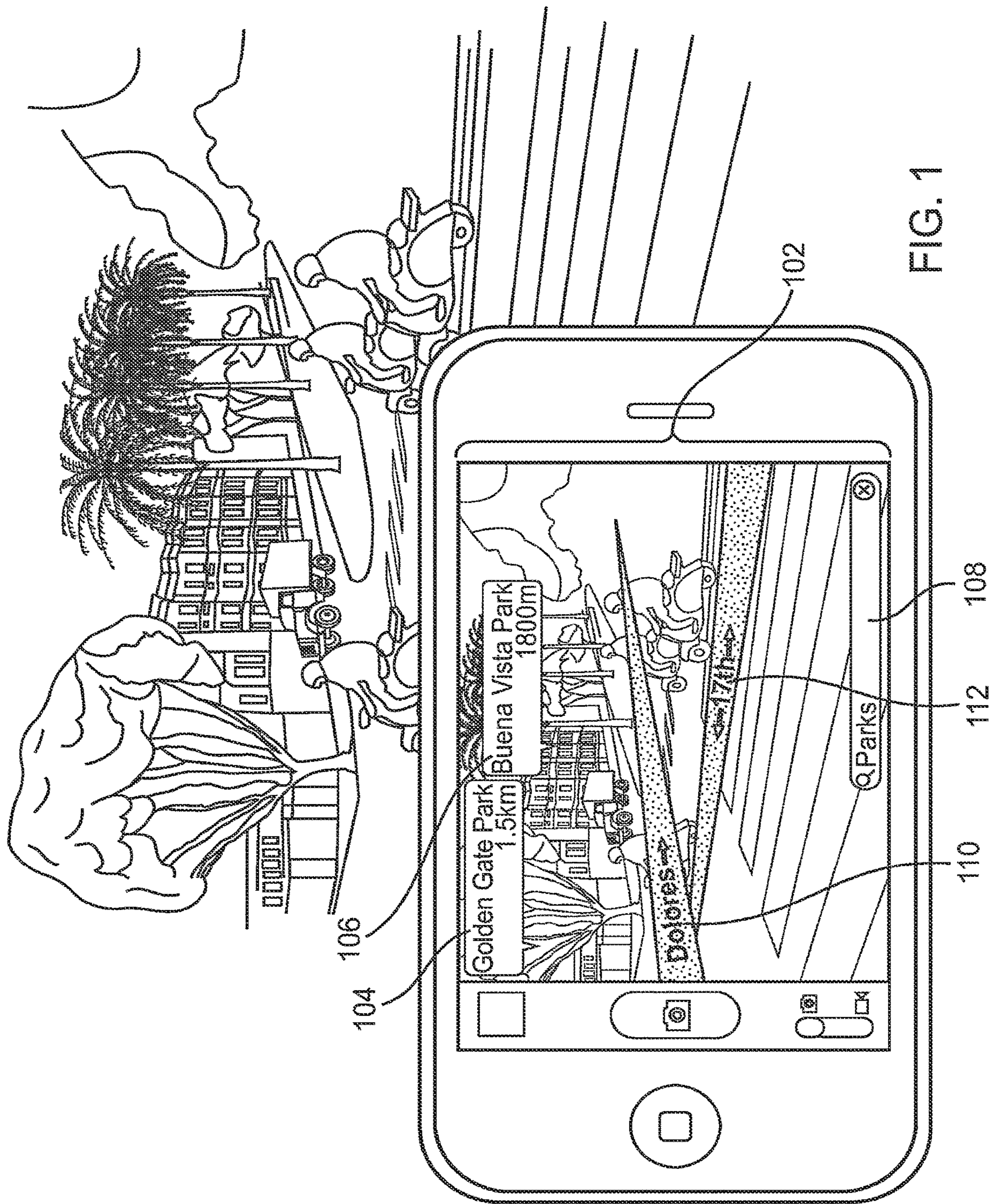

FIG. 1

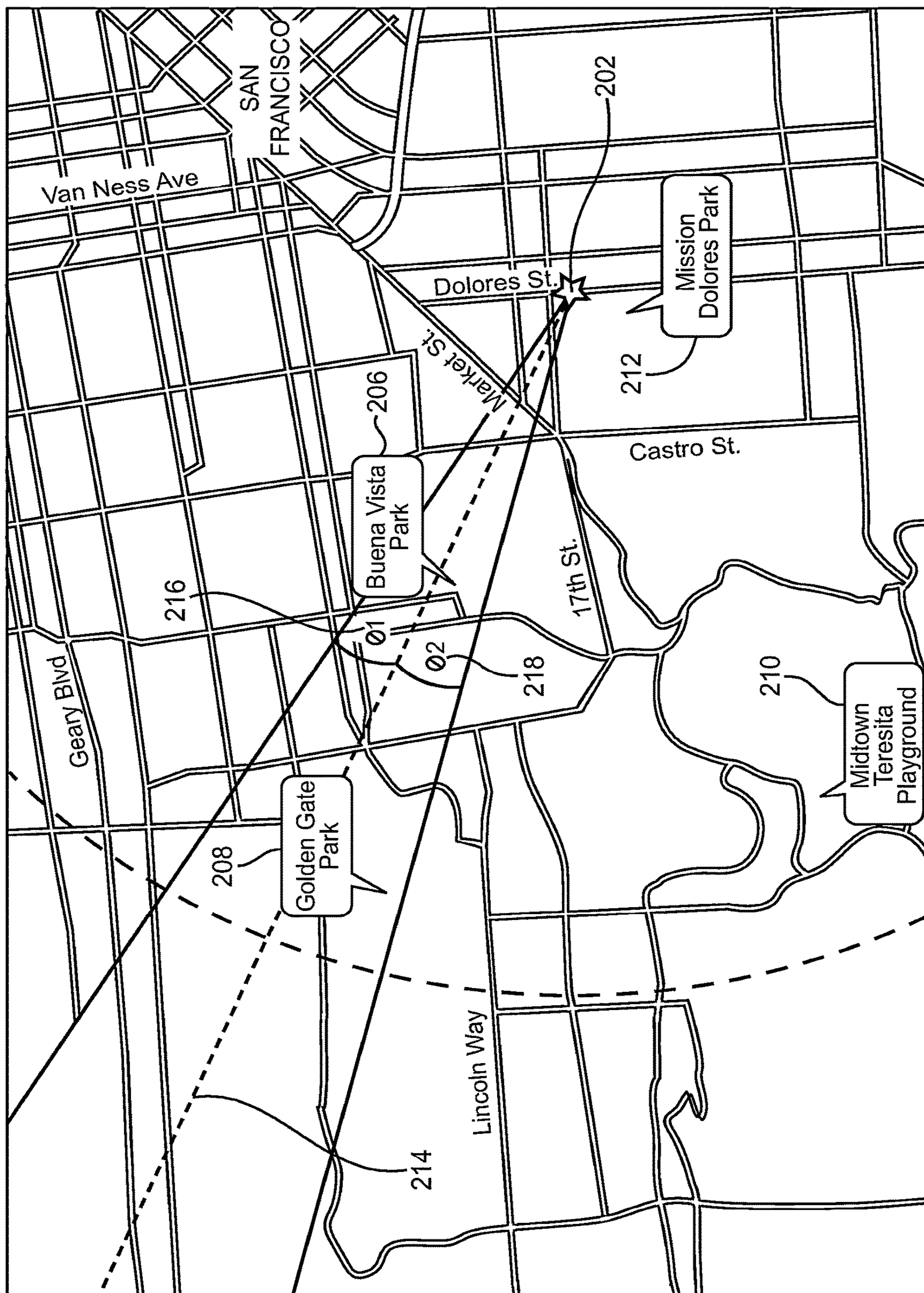

FIG. 2

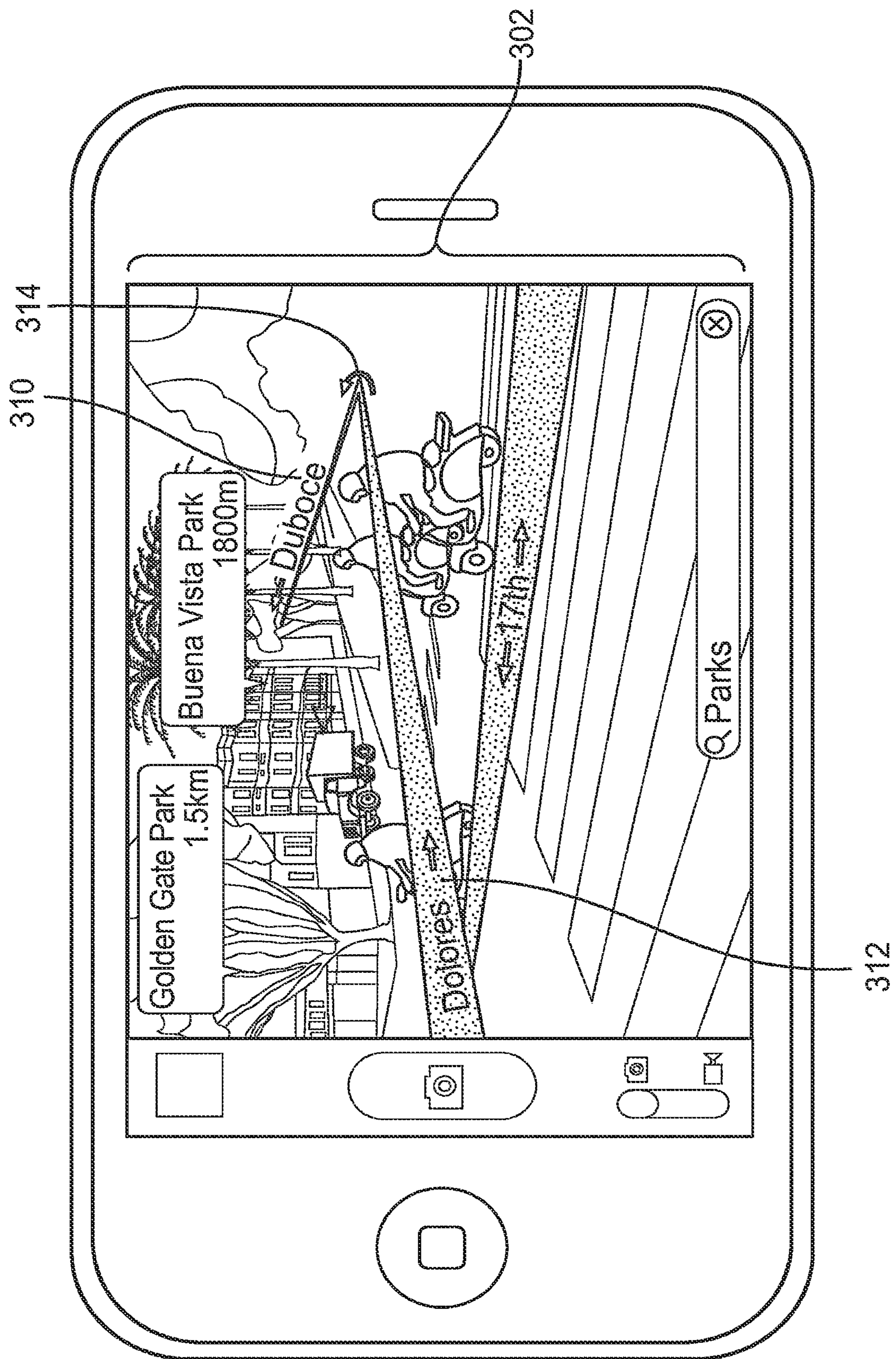

FIG. 3

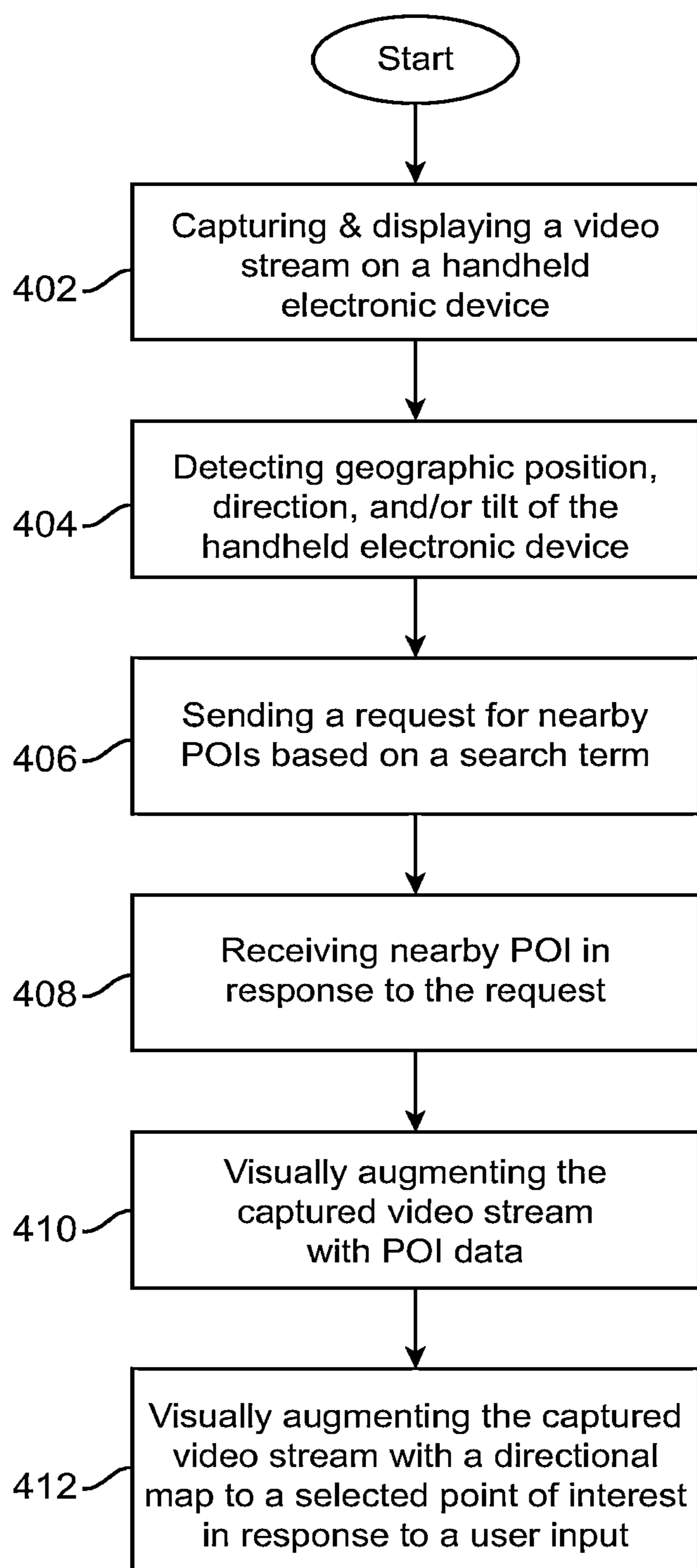

FIG. 4

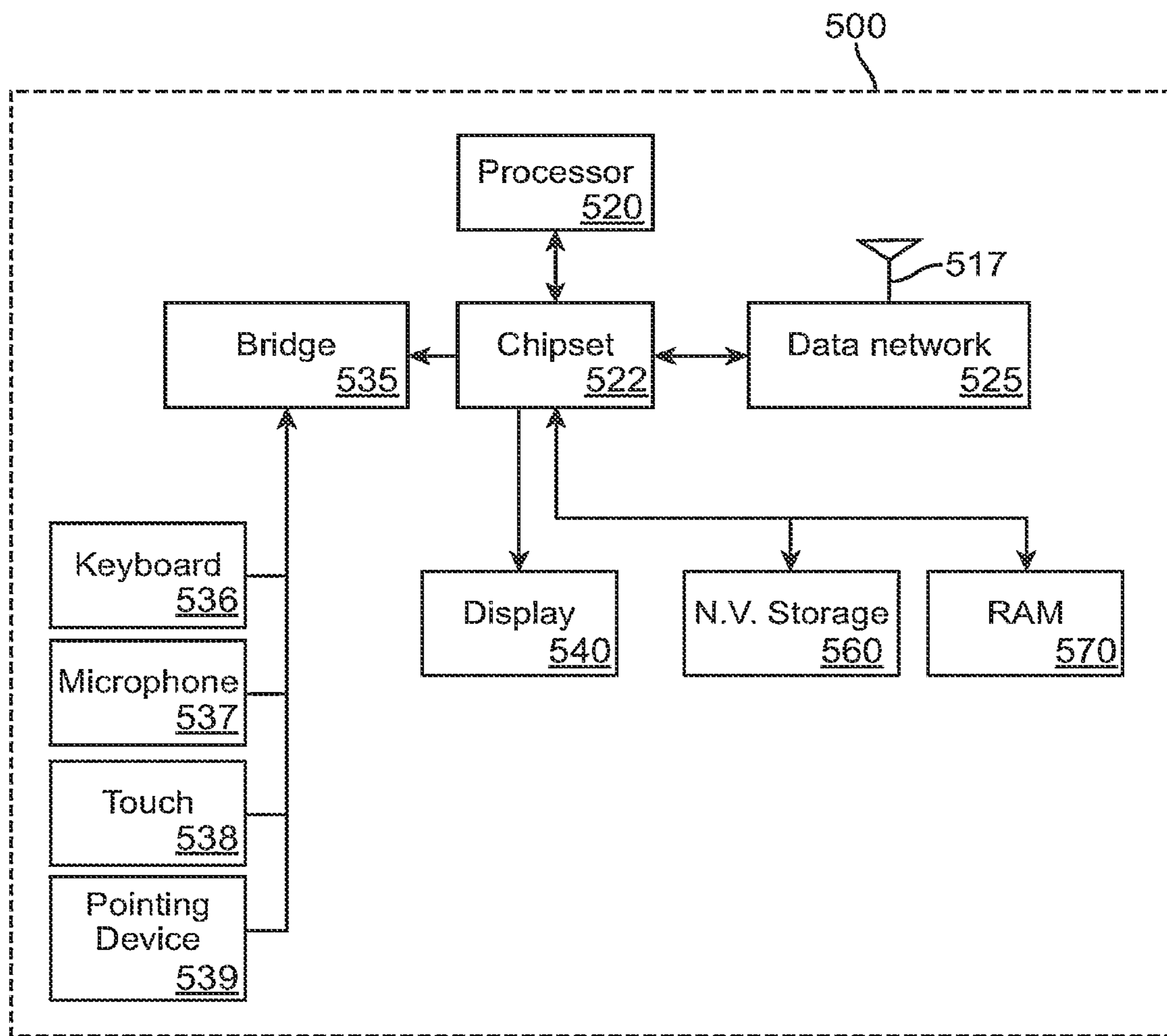

FIG. 5

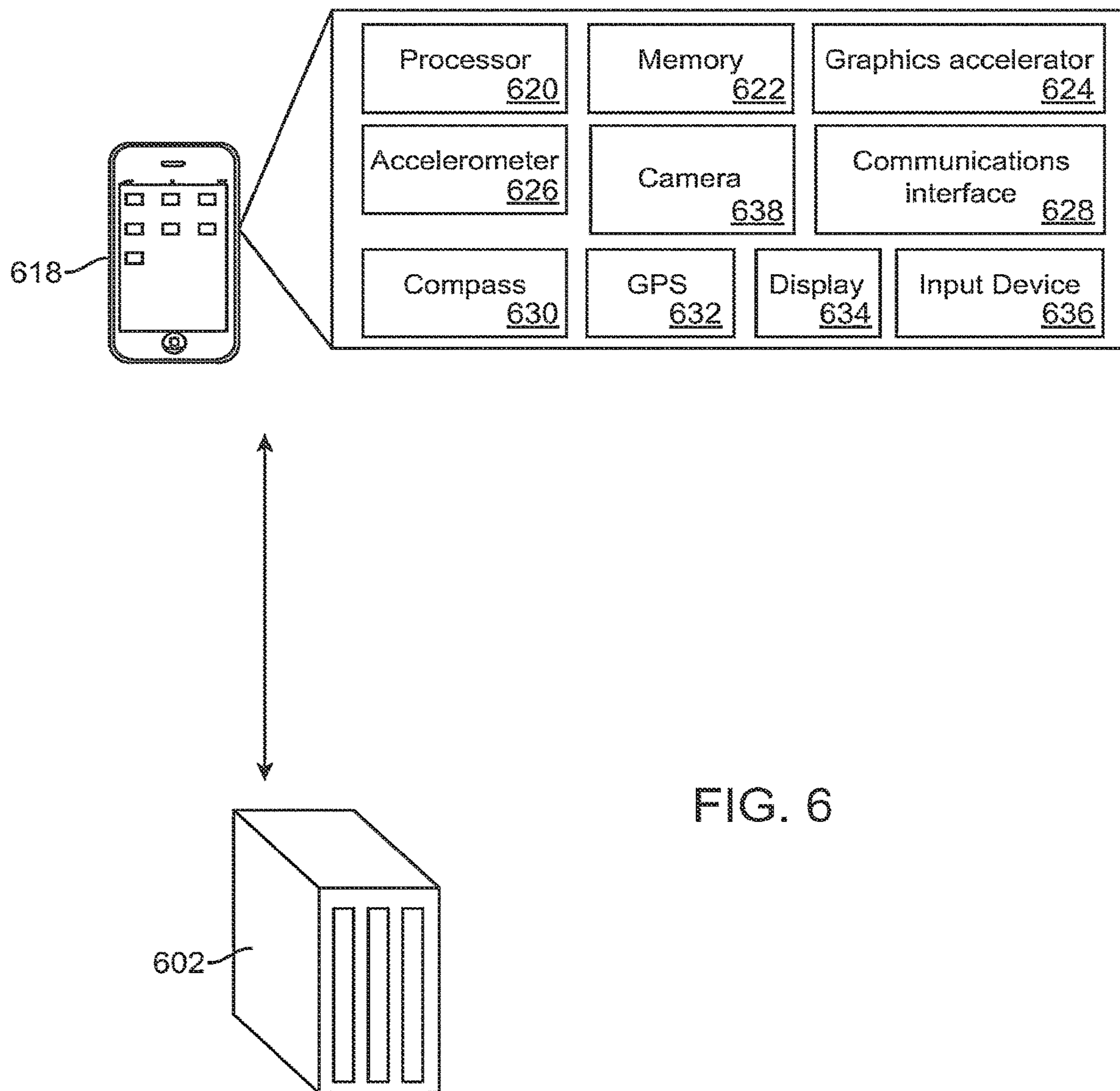

FIG. 6

AUGMENTED REALITY MAPS

RELATED APPLICATIONS

[0001] This application is a continuation of U.S. patent application Ser. No. 17/000,861 filed Aug. 24, 2020, soon to be U.S. Pat. No. 11,692,842, which is a continuation of U.S. patent application Ser. No. 15/341,915 filed Nov. 2, 2016, now U.S. Pat. No. 10,760,922, which is a continuation of U.S. patent application Ser. No. 12/705,558 filed on Feb. 12, 2010, now U.S. Pat. No. 9,488,488; the contents of which are incorporated by reference in their entirety for all purposes.

FIELD

[0002] The following relates to searching for nearby points of interest, and more particularly to displaying information related to nearby points of interest overlaid onto a video feed of a surrounding area.

BACKGROUND

[0003] Augmented reality systems supplement reality, in the form of a captured image or video stream, with additional information. In many cases, such systems take advantage of a portable electronic device's imaging and display capabilities and combine a video feed with data describing objects in the video. In some examples, the data describing the objects in the video can be the result of a search for nearby points of interest.

[0004] For example, a user visiting a foreign city can point a handheld communication device and capture a video stream of a particular view. A user can also enter a search term, such as museums. The system can then augment the captured video stream with search term result information related to nearby museums that are within the view of the video stream. This allows a user to supplement their view of reality with additional information available from search engines.

[0005] However, if a user desires to visit one of the museums, the user must switch applications, or at a minimum, switch out of an augmented reality view to learn directions to the museum. However, such systems can fail to orient a user's with a poor sense of direction and force the user to correlate the directions with objects in reality. Such a transition is not always as easy as it might seem. For example, an instruction that directs a user to go north on Main St. assumes that the user can discern which direction is north. Further, in some instances, street signs might be missing or indecipherable, making it difficult for the user to find the directed route.

SUMMARY

[0006] Such challenges can be overcome using the present technology. Therefore, a method and system for displaying augmented reality maps are disclosed. By interpreting the data describing the surrounding areas, the device can determine what objects are presently being viewed on the display. The device can further overlay information regarding the presently viewed objects, thus enhancing reality. In some embodiments, the device can also display search results overlaid onto the displayed video feed. Search results need not be actually viewable by a user in real life. Instead, search results can also include more-distant objects.

[0007] The user can interact with the display using an input device such as a touch screen. Using the input device, the user can select from among objects represented on the screen, including the search results.

[0008] In one form of interaction, a device can receive an input from the user requesting directions from a present location to a selected search result. Directions can be overlaid onto the presently displayed video feed, thus showing a course and upcoming turns. As the user and associated device progress along a route, the overlaid directions can automatically update to show the updated path.

[0009] In some embodiments the display can also include indicator graphics to point the user in a proper direction. For example, if the user is facing south but a route requires the user to progress north, "no route" would be displayed in the display because the user would be looking to the south but the route would be behind him or her. In such instances, an indicator can point the user in the proper direction to find the route.

[0010] In some embodiments, multiple display views can be presented based on the orientation of the device. For example, when the device is held at an angle with respect to the ground of 45 degrees to 180 degrees, the display view can present the augmented reality embodiments described herein. However, when the device is held at an angle less than 45 degrees, an illustrated or schematic view can be represented. In such embodiments, when the device is held at an angle with respect to the ground of less than 45 degrees, the device is likely pointed at the ground, where few objects of interest are likely to be represented in the displayed video. In such instances, a different map view is more likely to be useful. It should be appreciated that precise range of tilt can be adjusted according to the actual environment or user preferences.

[0011] In practice, a user points a handheld communication device to capture and display a real-time video stream of a view. The handheld communication device detects a geographic position, camera direction, and tilt of the image capture device. The user sends a search request to a server for nearby points of interest. The handheld communication device receives search results based on the search request, geographic position, camera direction, and tilt of the handheld communication device. The handheld communication device visually augments the captured video stream with data related to each point of interest. The user then selects a point of interest to visit. The handheld communication device visually augments the captured video stream with a directional map to a selected point of interest in response to the user input.

[0012] A method of augmenting a video stream of a device's present surrounding with navigational information is disclosed. The user can instruct the device to initiate a live video feed using an onboard camera and display the captured video images on a display. By polling a Global Positioning System (GPS) device, a digital compass, and optionally, an accelerometer, location, camera direction, and orientation information can be determined. By using the location, camera direction, and orientation information, the device can request data describing the surrounding areas and the objects therein. In some embodiments, this data includes map vector data. The can be requested from an onboard memory or a server. The data describing surrounding areas can further be requested in conjunction with a search

request. The search request can also include a request for information about nearby places of interest.

BRIEF DESCRIPTION OF THE DRAWINGS

[0013] FIG. 1 illustrates an exemplary visually augmented captured image with data related to a search for points of interest;

[0014] FIG. 2 illustrates the results of a field-of-view and point-of-interest search;

[0015] FIG. 3 illustrates an exemplary captured image visually augmented with a route to a selected point of interest;

[0016] FIG. 4 is a flow chart illustrating an exemplary method of preparing and displaying an augmented reality map;

[0017] FIG. 5 is a schematic illustration of an exemplary system embodiment; and

[0018] FIG. 6 is a schematic illustration of an exemplary system embodiment.

DESCRIPTION

[0019] The technology described herein visually augments a captured image or video stream with data for points of interest related to search terms entered by the user. The technology also visually augments the captured image or video stream with a directional map to a selected point of interest.

[0020] FIG. 1 is a screenshot illustrating an augmented reality embodiment as described herein. As illustrated, a handheld communication device has captured an image 102 of the northwest corner of the intersection of Dolores St. 17th St. using its image-capturing device and displayed the image on its display. In this way, the display can function as a viewfinder. As illustrated, the captured image 102 has been augmented with information corresponding to points of interest 104, 106 and street labels 110, 112.

[0021] FIG. 1 illustrates a captured and presented image 102 using an image capture device, i.e., the camera of a smart phone, which is but one type of handheld communication device to which the present disclosure can be applied. In this illustrated embodiment, the user has entered a search term “parks” in search bar 108 to conduct a search for nearby parks, i.e., a specific type of point of interest. Using map data that describes the area surrounding the present location of the device and the points of interest located in the surrounding area, the device augments the displayed image with additional information. In this instance, the smart phone or handheld communication device displays points of interest described by the data that are displayed in the viewfinder (such as Dolores St. 110 and 17th St. 112) or within a field of view and range from the geographic position of the device but that are obstructed by other in-screen objects, e.g., Golden Gate Park 104 and Buena Vista Park 106. While other parks might also be nearby, they are not shown because they fall outside the field of view of the device. However, the user could locate these parks by panning the device around the intersection, in which case those parks would appear on the screen.

[0022] In the captured image 102, the handheld communication device augments the captured image with bubbles showing the relative geographic position of “Golden Gate Park” 104 and “Buena Vista Park” 106 within the captured image 102. This allows the user to determine a general

direction to a point of interest. A user can then select a point of interest, e.g., by selecting the “Buena Vista Park” 106 point of interest information bubble, e.g., by touching the point of interest information bubble with a finger or stylus if the smart phone employs a touch screen. In other implementations, a cursor and mouse can be used to select a desired point of interest.

[0023] Points of interest can be any map feature, but most often a point of interest can be a map feature that identified as result of a search for a category of such map features. For example, a point of interest can be a park when a user searches for nearby parks. Likewise a point of interest can be places, buildings, structures, even friends that can be located on a map, when the point of interest is searched for. In some instances a point of interest is not necessarily identified as a result of a search. A point of interest can also be a map feature that is identified by the present system because it can be viewed in the captured image. In short, a point of interest can be any map feature for which the user has an interest.

[0024] FIG. 2 illustrates search results for point of interest results for nearby parks based on geographic position and also illustrates how a range and field of view correspond to the results displayed in the viewfinder. A handheld communication device captures a video stream of the view as shown in FIG. 1. The handheld communication device detects the geographic position, camera direction, and tilt of the handheld communication device.

[0025] The geographic position of the handheld communication device can be determined using GPS coordinates or using triangulation methods using cell phone towers. In yet another example, a blend of GPS coordinates and triangulation information can be used to determine the position of the device.

[0026] The camera direction is a direction relative to a planet’s magnetic field (i.e., Earth’s magnetic field) in which the camera is pointing. The camera direction can be considered a direction that can be identified using a compass, such as a digital compass. The camera direction can be used to identify the direction in which the camera is pointing as it acquires an image to be augmented using the present technology.

[0027] The tilt direction is a direction that determines the direction in which either the camera device or display device is pointing relative to a horizontal or vertical axis. The tilt direction can most commonly be determined using an accelerometer.

[0028] The user can enter a search request for nearby points of interest based on a search term. In this example, upon entry by the user of a search for nearby “Parks” the handheld communication device sends a request for data related to nearby parks to a map database.

[0029] Either the request itself, or the database being queried can determine a relevant range from within which search results must be encompassed. Upon receipt of the request, the database will return search results for points of interest related to the search term that are also within a defined radius of the handheld communication device as illustrated in FIG. 2. As shown in this example, the server returned points of interest “Golden Gate Park” 208, “Buena Vista Park” 206, “Midtown Terrace Playground” 210, and “Mission Dolores Park” 212. The handheld communication device determines that of the point-of-interest search results, only “Golden Gate Park” 208 and “Buena Vista Park” 206

are within the field of view of the handheld communication device. The point-of-interest results “Golden Gate Park” **208** and “Buena Vista Park” **206** are displayed with their relative spatial relationship to the handheld communication device. In the example shown in FIG. 2, the camera direction of the handheld communication device is northwest.

[0030] A field of view can be determined using a digital compass to inform the device of the camera direction in which the camera is facing or, alternatively, the user could enter in a heading. As explained above, in FIGS. 1 and 2, the camera is facing northwest and its theoretical line of sight is represented as **214** in FIG. 2. Any search results that are to be displayed on the viewfinder must be within a certain angle of line **214**. For example, a camera on a handheld communication device might only be able to display range of view encompassing degrees. In such an instance, a given display would represent those items encompassed within 15 degrees in each direction from the center of the field of view. This concept is illustrated in FIG. 2 wherein **214** illustrates the center of the field of view and angles θ_1 **216**= θ_2 **218** and they represent angles from the center of the field of view to the outer limits of the field of view. A distance from the device’s geographic location can also be used to define a field of view. As discussed above, a distance or range can be defined by the device in its request for search results or by the database serving the request. Only search results encompassed in this field of view will be displayed on the display.

[0031] In some embodiments, a device can also use an accelerometer to inform the device of what objects are displayed in its viewfinder. For example, if the device is in a hilly location, the accelerometer can tell the device that it is pointing downhill. In another example, the device can determine that, due to the topography surrounding its present location (described by map data) an object viewed at a certain angle from the horizon must be a neighboring hill or mountain peak in the distance. In yet another example, an angle from a horizon can indicate that the user is viewing a multiple story building having places of interest in multiple stories of the building. An accelerometer can inform the device of the angle at which the device is pointed.

[0032] FIG. 3 illustrates a captured image that has been visually augmented with route data to a selected point of interest. In this example, a user has selected the “Buena Vista Park” point of interest and, in response, the smart phone has visually augmented the captured image **302** with a directional map **310** to the selected point of interest, i.e., “Buena Vista Park”. The route shows a direction **312** that the user must travel on Dolores St. to begin travelling to reach “Buena Vista Park.” The directional map **310** further indicates a turn **314** that the user must take, i.e., a turn left onto Duboce Ave. from Dolores St. In the illustrated example, the map is shown overlaid onto Dolores St.

[0033] The route **310** guides the user with complete navigation illustrations to reach “Buena Vista Park,” including any required turns. In some embodiments, the route can be represented as a schematic map, i.e., a simplified map that includes only relevant information for the user in an easy-to-read format.

[0034] A schematic map can be thought of as similar to a subway map one would see on a subway train. While the subway track itself might wind and turn, a typical subway map represents the subway route as a mostly straight line. Further, the subway map often does not have any particular scale and frequently shows every destination approximately

evenly dispersed along the route. Thus, a schematic map as discussed below is one that does not adhere to geographic “reality,” but rather represents map features in a schematic fashion by illustrating directions as a route made of one or more roads, trails, or ways that can be represented as substantially straight lines instead of by their actual shapes (which would be represented in a non-schematic map by adhering to geographic reality). The schematic map can also be devoid of uniform scale. Thus, in some parts of the map, such as an area of the map representing a destination, such area can be “distorted” somewhat to clearly illustrate important details, while map areas that represent portions of a route where there are no turns or other significant features can be very condensed. In short, the map can be a schematic of the real world that can provide a simple and clear representation that is sufficient to aid the user in guidance or orientation without displaying unnecessary map features or detail that could otherwise clutter a small display space.

[0035] FIG. 4 is a flow chart illustrating an exemplary method of preparing and displaying an augmented reality map. As shown at block **402**, the method includes capturing and displaying a video stream on a handheld communication device. Although described here in reference to a video stream, another embodiment of the disclosed technology includes capturing and displaying a single still image or a series of still images.

[0036] As shown at block **404**, the method includes detecting geographic position, camera direction, and/or tilt of the handheld communication device. This allows the device to determine features, such as streets, buildings, points of interest, etc., that are within a field of view for the captured video stream.

[0037] As shown at block **406**, the method includes sending a request for nearby points of interest based on one or more search terms. For example, the user can search for nearby hotels, parks, or restaurants. The request can be sent to a database located on a server that is separate from the handheld communication device and communicate via a wireless protocol. In another embodiment, the database can be stored locally on the device and the search request remains internal (sometimes termed “onboard” the device) to the handheld communication device.

[0038] In block **408**, the method includes receiving nearby points of interest in response to the request. The server can filter point of interest results in one example. In this example, if the number of returned points of interest exceeds a set threshold, the server can filter the results to only return a fixed number of the best results. Various algorithms can be employed to filter points of interest to a desired number for visual augmentation of a captured video stream. In another embodiment, the handheld communication device can filter point-of-interest results received from the server for optimal display on a handheld communication device.

[0039] In block **410**, the handheld communication device visually augments the captured video stream with data related to each point of interest. As shown in FIG. 2, the handheld communication device can visually augment a captured video stream with a bubble for each point of interest within the field of view for the handheld communication device. The handheld communication device determines which points of interest are within its field of view by analyzing the geographic position, camera direction, and/or

tilt of the handheld communication device in concert with the known geographic position of the returned points of interest.

[0040] In block 412, the handheld communication device visually augments the captured video stream with a directional map to a selected point of interest in response to the user input. For example, as described in connection with FIG. 3, the smart phone now visually augments the captured image 302 with a directional map 310 to the selected point of interest in response to the user input. The user input can be a selection of a displayed point of interest to indicate that the user wishes to view navigation data for reaching the selected point of interest.

[0041] In some embodiments, the display can also include indicator graphics to point the user in a proper direction. For example, if the user is facing south but a route requires the user to progress north, “no route” would be shown in the display because the route would be behind him or her. In such instances, an indicator can point the user in the proper direction to find the displayed route.

[0042] In some embodiments, multiple display views can be presented based on the orientation of the device. For example, when the device is held at an angle with respect to the ground of 45 degrees to 180 degrees, the display view can present the augmented reality embodiments described herein. However, when the device is held at an angle less than 45 degrees, an illustrated or schematic view can be presented. In such embodiments, when the device is held at an angle with respect to the ground of less than 45 degrees, the device is likely pointed at the ground, where few objects of interest are likely to be represented in the displayed video. In such instances, a different map view than the augmented reality map is more likely to be useful. It should be appreciated that precise range of tilt can be adjusted according to the actual environment or user preferences.

[0043] FIG. 5 illustrates a computer system 500 used to execute the described method and generate and display augmented reality maps. Computer system 500 is an example of computer hardware, software, and firmware that can be used to implement the disclosures above. System 500 includes a processor 520, which is representative of any number of physically and/or logically distinct resources capable of executing software, firmware, and hardware configured to perform identified computations. Processor 520 communicates with a chipset 522 that can control input to and output from processor 520. In this example, chipset 522 outputs information to display 540 and can read and write information to non-volatile storage 560, which can include magnetic media and solid state media, for example. Chipset 522 also can read data from and write data to RAM 570. A bridge 535 for interfacing with a variety of user interface components can be provided for interfacing with chipset 522. Such user interface components can include a keyboard 536, a microphone 537, touch-detection-and-processing circuitry 538, a pointing device such as a mouse 539, and so on. In general, inputs to system 500 can come from any of a variety of machine-generated and/or human-generated sources.

[0044] Chipset 522 also can interface with one or more data network interfaces 525 that can have different physical interfaces 517. Such data network interfaces can include interfaces for wired and wireless local area networks, for broadband wireless networks, as well as personal area networks. Some applications of the methods for generating

and displaying and using the augmented reality user interface disclosed herein can include receiving data over physical interface 517 or be generated by the machine itself by processor 520 analyzing data stored in memory 560 or 570. Further, the machine can receive inputs from the user via devices keyboard 536, microphone 537, touch device 538, and pointing device 539 and execute appropriate functions, such as browsing functions by interpreting these inputs using processor 520.

[0045] While FIG. 5 illustrates an example of a common system architecture, it should also be appreciated that other system architectures are known and can be used with the present technology. For example, systems wherein most or all of the components described within FIG. 5 can be joined to a bus, or the peripherals could write to a common shared memory that is connected to a processor or a bus can be used. Other hardware architectures are possible and such are considered to be within the scope of the present technology.

[0046] FIG. 6 illustrates an exemplary system embodiment. A server 602 is in electronic communication with a handheld communication device 618 having functional components such as a processor 620, memory 622, graphics accelerator 624, accelerometer 626, communications interface 628, compass 630, GPS 632, display 634, input device 636, and camera 638. None of the devices are limited to the illustrated components. The components may be hardware, software, or a combination of both.

[0047] In some embodiments, the server can be separate from the handheld communication device. The server and handheld communication device can communicate wirelessly, over a wired-connection, or through a mixture of wireless and wired connections. The handheld communication device can communicate with the server over a TCP/IP connection. In another embodiment, the handheld communication device can be directly connected to the server. In another embodiment, the handheld communication device can also act as a server and store the points of interest locally.

[0048] In some embodiments, instructions are input to the handheld electronic device 618 through an input device 636 that instructs the processor 620 to execute functions in an augmented reality application. One potential instruction can be to generate an augmented reality map of travel directions to a point of interest. In that case, the processor 620 instructs the camera 638 to begin feeding video images to the display 634. In some embodiments, video images recorded by the camera are first sent to graphics accelerator 624 for processing before the images are displayed. In some embodiments, the processor can be the graphics accelerator. The image can be first drawn in memory 622 or, if available, memory directly associated with the graphics accelerator 624.

[0049] The processor 620 can also receive location and orientation information from devices such as a GPS device 632, communications interface 628, digital compass 630 and accelerometer 626. The GPS device can determine GPS coordinates by receiving signals from Global Positioning System (GPS) satellites and can communicate them to the processor. Likewise, the processor can determine the location of the device through triangulation techniques using signals received by the communications interface 628. The processor can determine the orientation of the device by receiving directional information from the digital compass 630 and tilt information from the accelerometer.

[0050] The processor can also direct the communications interface to send a request to the server **602** for map data corresponding to the area surrounding the geographical location of the device. In some embodiments, the processor can receive signals from the input device, which can be interpreted by the processor to be a search request for map data including features of interest.

[0051] The processor can interpret the location and orientation data received from the accelerometer **626**, compass **630**, or GPS **632** to determine the direction in which the camera **638** is facing. Using this information, the processor can further correlate the location and orientation data with the map data and the video images to identify objects recorded by the camera **638** and displayed on the display **634**.

[0052] The processor can receive other inputs via the input device **636** such as an input that can be interpreted as a selection of a point of interest displayed on the display **634** and a request for directions. The processor **620** can further interpret the map data to generate and display a route over the displayed image for guiding the user to a destination (selected point of interest).

[0053] As the user follows the specified direction to the selected points of interest, the processor can continue to receive updated location and directional information and video input and update the overlaid route.

[0054] Methods according to the above-described examples can be implemented using computer-executable instructions that are stored or otherwise available from computer-readable media. Such instructions comprise, for example, instructions and data which cause or otherwise configure a general-purpose computer, a special-purpose computer, or a special-purpose processing device to perform a certain function or group of functions. Portions of computer resources used can be accessible over a network. The computer-executable instructions may be, for example, binaries, intermediate format instructions such as assembly language, firmware, or source code. Examples of computer-readable media that may be used to store instructions, information to be used, and/or information created during methods according to described examples include magnetic or optical disks, flash memory, USB devices provided with non-volatile memory, networked storage devices, and so on.

[0055] Devices implementing methods according to this disclosure can comprise hardware, firmware, and/or software and can take any of a variety of form factors. Typical examples of such form factors include laptops, smart phones, small-form-factor personal computers, personal digital assistants, and so on. Functionality described herein also can be embodied in peripherals or add-in cards. Such functionality also can be implemented on a circuit board among different chips or different processes executing in a single device, by way of further example.

[0056] The instructions, media for conveying such instructions, computing resources for executing them, and other structures for supporting such computing resources are means for providing the functions described in this disclosure.

[0057] Although a variety of examples and other information have been used to explain various aspects within the scope of the appended claims, no limitation of the claims should be implied based on particular features or arrangements in such examples, as one of ordinary skill would be able to use these examples to derive a wide variety of

implementations. Furthermore, and although some subject matter may have been described in language specific to examples of structural features and/or method steps, it should be understood that the subject matter defined in the appended claims is not necessarily limited to those described features or acts. For example, functionality of the various components can be distributed differently or performed in components other than those identified herein. Therefore, the described features and steps are disclosed as examples of components of systems and methods that are deemed to be within the scope of the following claims.

1. (canceled)
2. A method implemented on handheld communication device including a processor, an image capture component, and a display, the method comprising:
 - determining a current angle of the handheld communication device;
 - determining whether the current angle meets one or more criteria for displaying an augmented reality map that displays captured images augmented with additional information;
 - responsive to determining that the current angle meets the one or more criteria, displaying the augmented reality map at least by:
 - capturing, by the handheld communication device, a video stream using the image capture component;
 - displaying, on the display, the video stream in real-time as the video stream is being captured;
 - augmenting the video stream, being displayed on the display in real-time, with information identifying a point of interest or a street that is within a field of view of the handheld communication device;
 - responsive to determining that the current angle does not meet the one or more criteria for displaying the augmented reality map: displaying, on the display, map information in a map view that is different than the augmented reality map.
3. The method of claim **2**, wherein the method further comprises determining the field of view of the handheld communication device at least by:
 - detecting a geographic position of the handheld communication device and a camera direction of a camera of the image capture component; and
 - determining a field of view based on the geographic position and the camera direction.
4. The method of claim **2**, wherein the method further comprises determining the field of view of the handheld communication device using a compass corresponding to the handheld communication device.
5. The method of claim **2**, wherein the current angle of the handheld communication device is measured with respect to the ground.
6. The method of claim **2**, wherein the criteria for displaying the augmented reality map comprises a range of angles for the handheld communication device, and wherein the method further comprises determining the range of angles based on at least one of: (a) an environment of the handheld communication device or (b) user preferences.
7. The method of claim **2**, wherein determining that the current angle meets the criteria for displaying the augmented reality map comprises determining that the angle of the handheld communication device with respect to the ground is between 45 degrees and 180 degrees.

- 8.** The method of claim **2**, wherein augmenting the video stream, being displayed on the display in real-time, with information identifying the point of interest or the street comprises: presenting a navigational instruction overlaid on the video stream, and wherein displaying map information in the map view that is different than the augmented reality map comprises: displaying a navigational instruction on a two-dimensional map.
- 9.** A handheld communication device including a processor, an image capture component, and a display, the handheld communication device being configured to perform operations comprising:
- determining a current angle of the handheld communication device;
 - determining whether the current angle meets one or more criteria for displaying an augmented reality map that displays captured images augmented with additional information;
 - responsive to determining that the current angle meets the one or more criteria, displaying the augmented reality map at least by:
 - capturing, by the handheld communication device, a video stream using the image capture component;
 - displaying, on the display, the video stream in real-time as the video stream is being captured;
 - augmenting the video stream, being displayed on the display in real-time, with information identifying a point of interest or a street that is within a field of view of the handheld communication device;
 - responsive to determining that the current angle does not meet the one or more criteria for displaying the augmented reality map: displaying, on the display, map information in a map view that is different than the augmented reality map.
- 10.** The handheld communication device of claim **9**, wherein the operations further comprise determining the field of view of the handheld communication device at least by:
- detecting a geographic position of the handheld communication device and a camera direction of a camera of the image capture component; and
 - determining a field of view based on the geographic position and the camera direction.
- 11.** The handheld communication device of claim **9**, wherein the operations further comprise determining the field of view of the handheld communication device using a compass corresponding to the handheld communication device.
- 12.** The handheld communication device of claim **9**, wherein the current angle of the handheld communication device is measured with respect to the ground.
- 13.** The handheld communication device of claim **9**, wherein the criteria for displaying the augmented reality map comprises a range of angles for the handheld communication device, and wherein the method further comprises determining the range of angles based on at least one of: (a) an environment of the handheld communication device or (b) user preferences.
- 14.** The handheld communication device of claim **9**, wherein determining that the current angle meets the criteria for displaying the augmented reality map comprises deter-

mining that the angle of the handheld communication device with respect to the ground is between 45 degrees and 180 degrees.

- 15.** The handheld communication device of claim **9**, wherein augmenting the video stream, being displayed on the display in real-time, with information identifying the point of interest or the street comprises: presenting a navigational instruction overlaid on the video stream, and wherein displaying map information in the map view that is different than the augmented reality map comprises: displaying a navigational instruction on a two-dimensional map.
- 16.** One or more non-transitory media comprising instructions which, when executed by one or more hardware processors, cause performance of a method by handheld communication device including a processor, an image capture component, and a display, the method comprising:
- determining a current angle of the handheld communication device;
 - determining whether the current angle meets one or more criteria for displaying an augmented reality map that displays captured images augmented with additional information;
 - responsive to determining that the current angle meets the one or more criteria, displaying the augmented reality map at least by:
 - capturing, by the handheld communication device, a video stream using the image capture component;
 - displaying, on the display, the video stream in real-time as the video stream is being captured;
 - augmenting the video stream, being displayed on the display in real-time, with information identifying a point of interest or a street that is within a field of view of the handheld communication device;
 - responsive to determining that the current angle does not meet the one or more criteria for displaying the augmented reality map: displaying, on the display, map information in a map view that is different than the augmented reality map.
- 17.** The one or more non-transitory media of claim **16**, wherein the method further comprises determining the field of view of the handheld communication device at least by:
- detecting a geographic position of the handheld communication device and a camera direction of a camera of the image capture component; and
 - determining a field of view based on the geographic position and the camera direction.
- 18.** The one or more non-transitory media of claim **16**, wherein the method further comprises determining the field of view of the handheld communication device using a compass corresponding to the handheld communication device.
- 19.** The one or more non-transitory media of claim **16**, wherein the current angle of the handheld communication device is measured with respect to the ground.
- 20.** The one or more non-transitory media of claim **16**, wherein the criteria for displaying the augmented reality map comprises a range of angles for the handheld communication device, and wherein the method further comprises determining the range of angles based on at least one of: (a) an environment of the handheld communication device or (b) user preferences.

21. The one or more non-transitory media of claim **16**, wherein determining that the current angle meets the criteria for displaying the augmented reality map comprises determining that the angle of the handheld communication device with respect to the ground is between 45 degrees and 180 degrees.

22. The one or more non-transitory media of claim **16**, wherein augmenting the video stream, being displayed on the display in real-time, with information identifying the point of interest or the street comprises: presenting a navigational instruction overlaid on the video stream, and

wherein displaying map information in the map view that is different than the augmented reality map comprises: displaying a navigational instruction on a two-dimensional map.

* * * * *