



US 20230400697A1

(19) **United States**

(12) **Patent Application Publication**
Sauers et al.

(10) **Pub. No.: US 2023/0400697 A1**

(43) **Pub. Date: Dec. 14, 2023**

(54) **SENSOR FOR HEAD-MOUNTED DISPLAY**

(60) Provisional application No. 62/558,401, filed on Sep. 14, 2017.

(71) Applicant: **APPLE INC.**, Cupertino, CA (US)

Publication Classification

(72) Inventors: **Jason C. Sauers**, Sunnyvale, CA (US);
Phil M. Hobson, Menlo Park, CA (US);
Edward S. Huo, Sunnyvale, CA (US);
Fletcher R. Rothkopf, Los Altos, CA (US)

(51) **Int. Cl.**
G02B 27/01 (2006.01)

(52) **U.S. Cl.**
CPC .. **G02B 27/0176** (2013.01); **G02B 2027/0169** (2013.01)

(21) Appl. No.: **18/239,378**

(57) **ABSTRACT**

(22) Filed: **Aug. 29, 2023**

A head-mounted display includes a housing. A support member is connected to the housing. A sensor is located on a front surface of the support member and is configured to measure a characteristic of a user. A compressible material is configured to be compressed against the front surface of the support member.

Related U.S. Application Data

(63) Continuation of application No. 16/118,504, filed on Aug. 31, 2018, now Pat. No. 11,774,768.

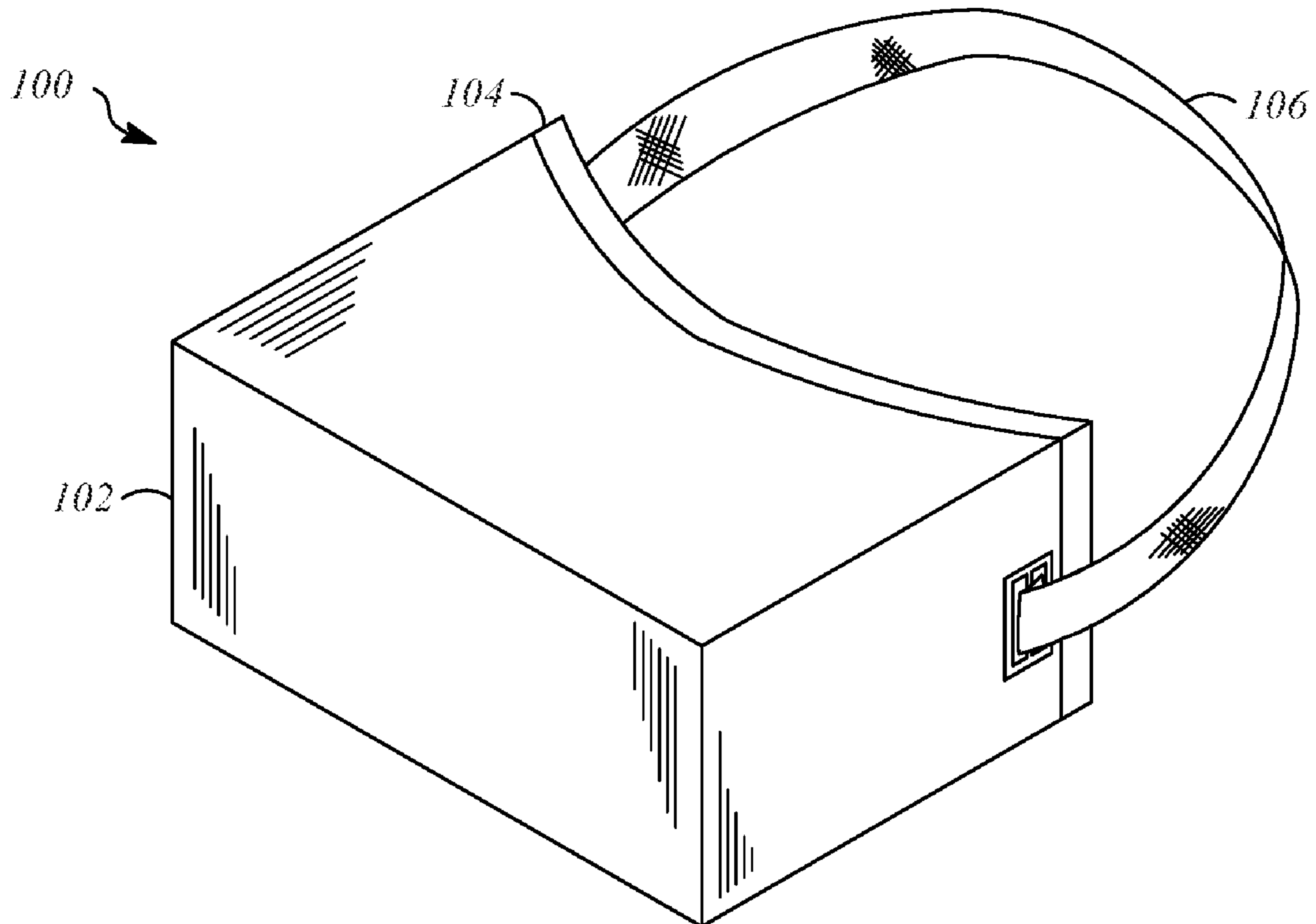

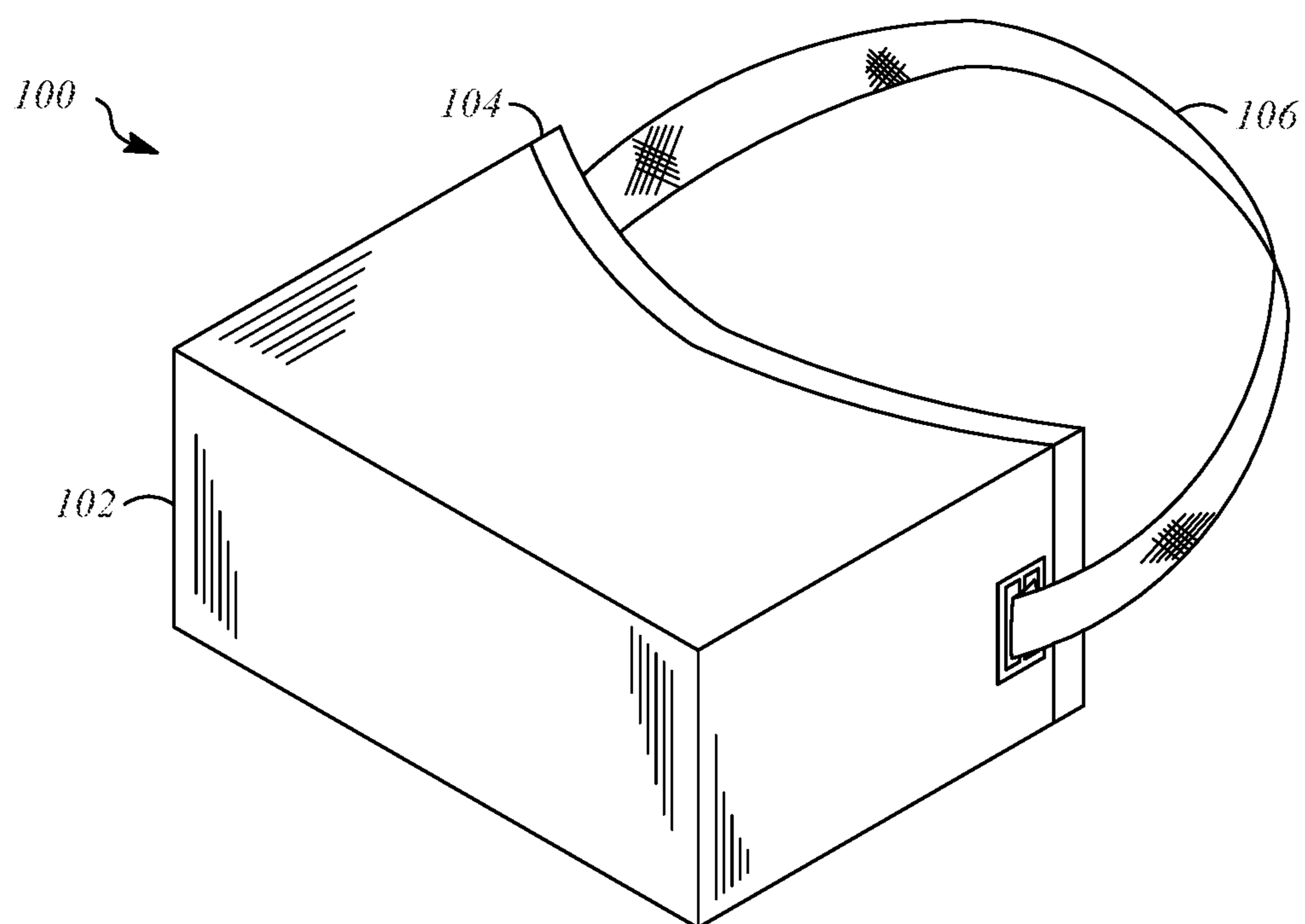

FIG. 1

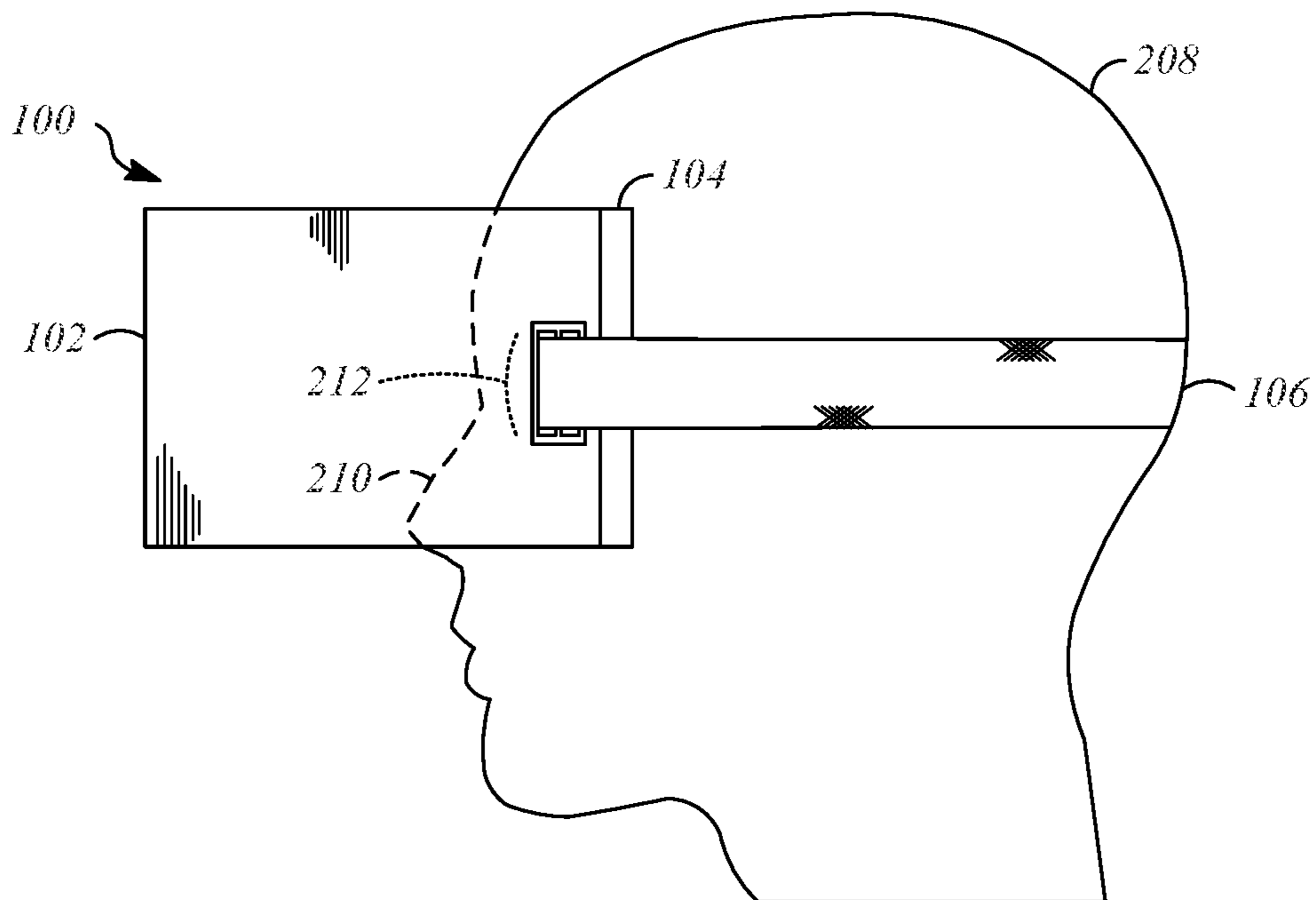

FIG. 2A

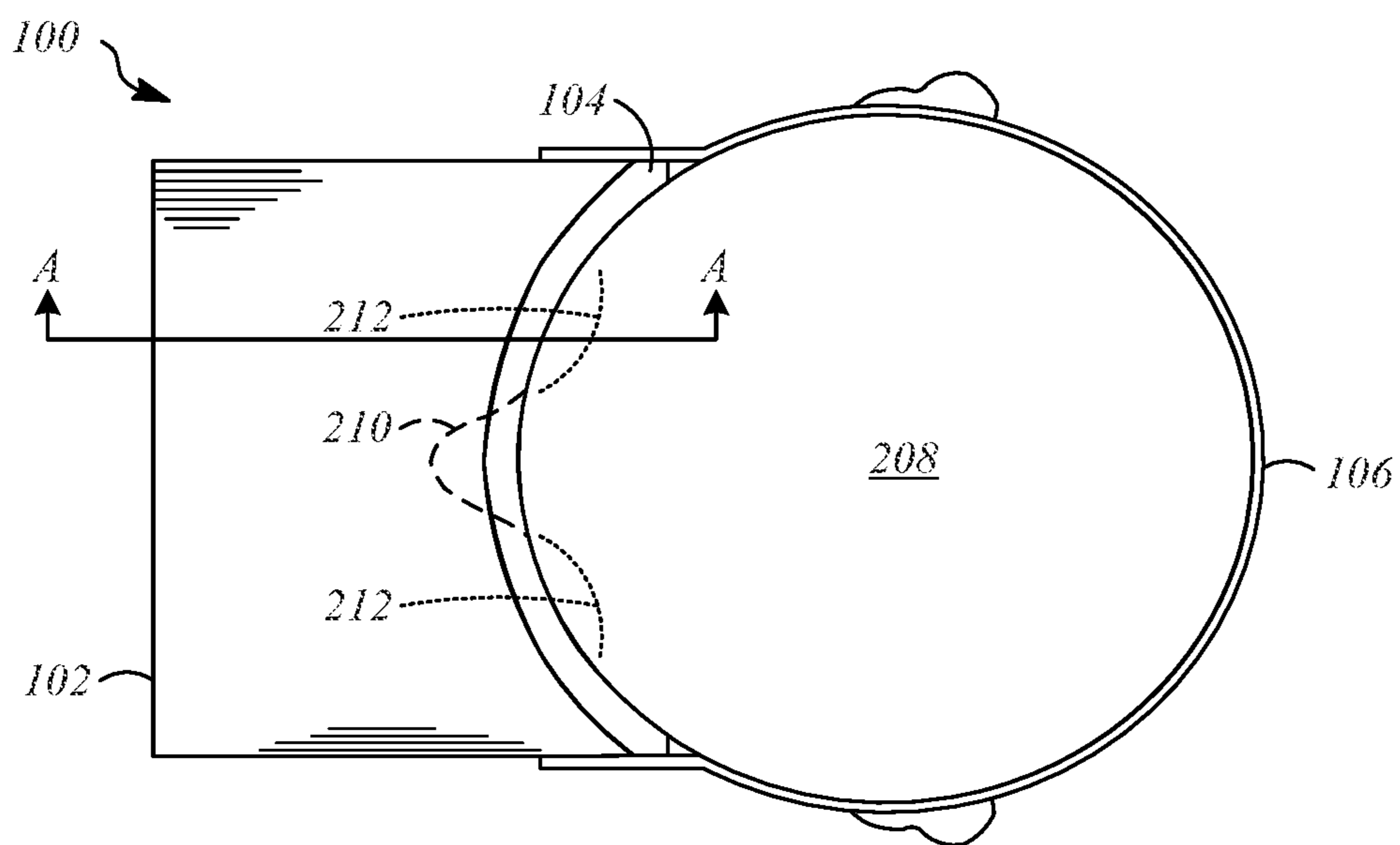

FIG. 2B

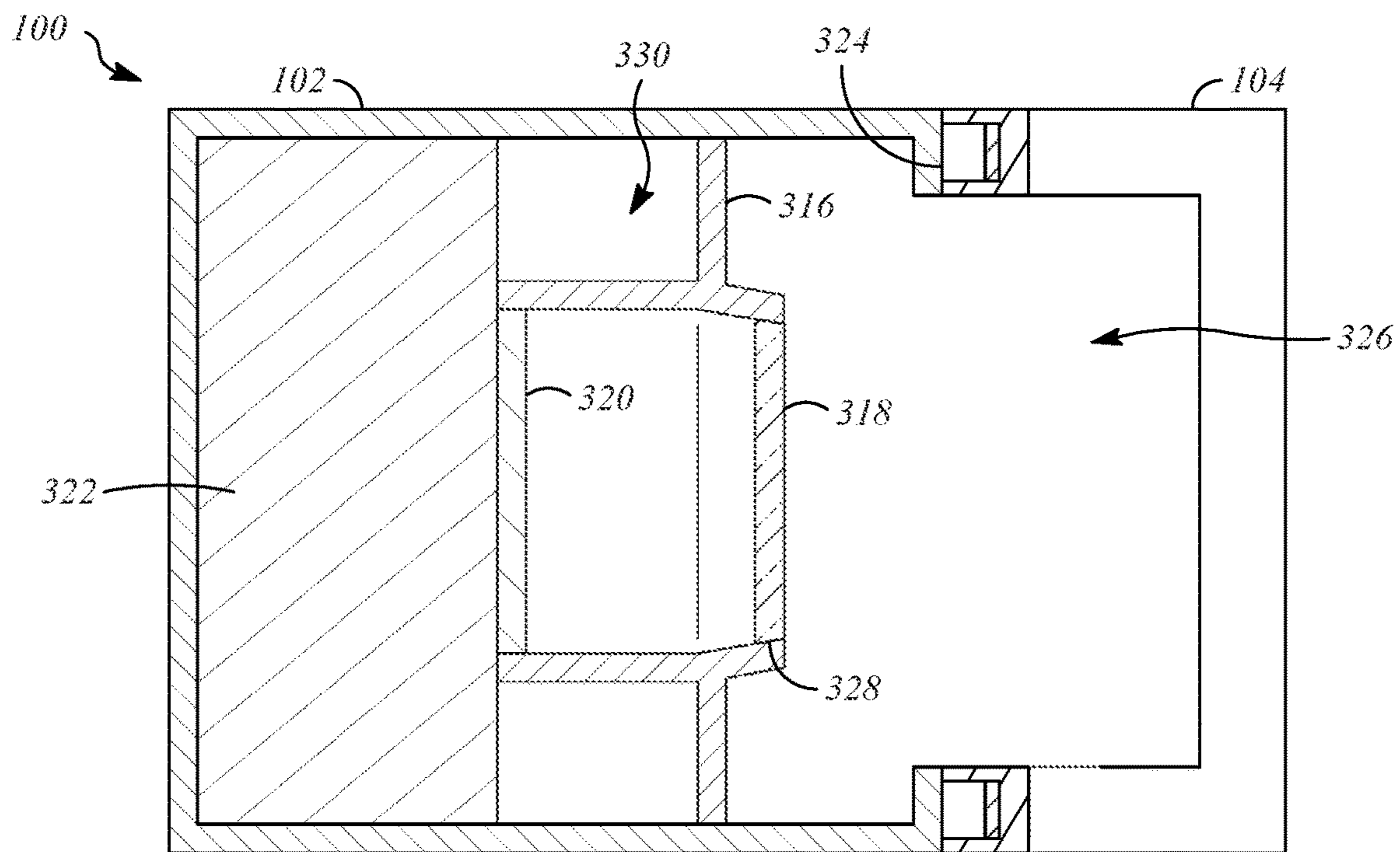

FIG. 3

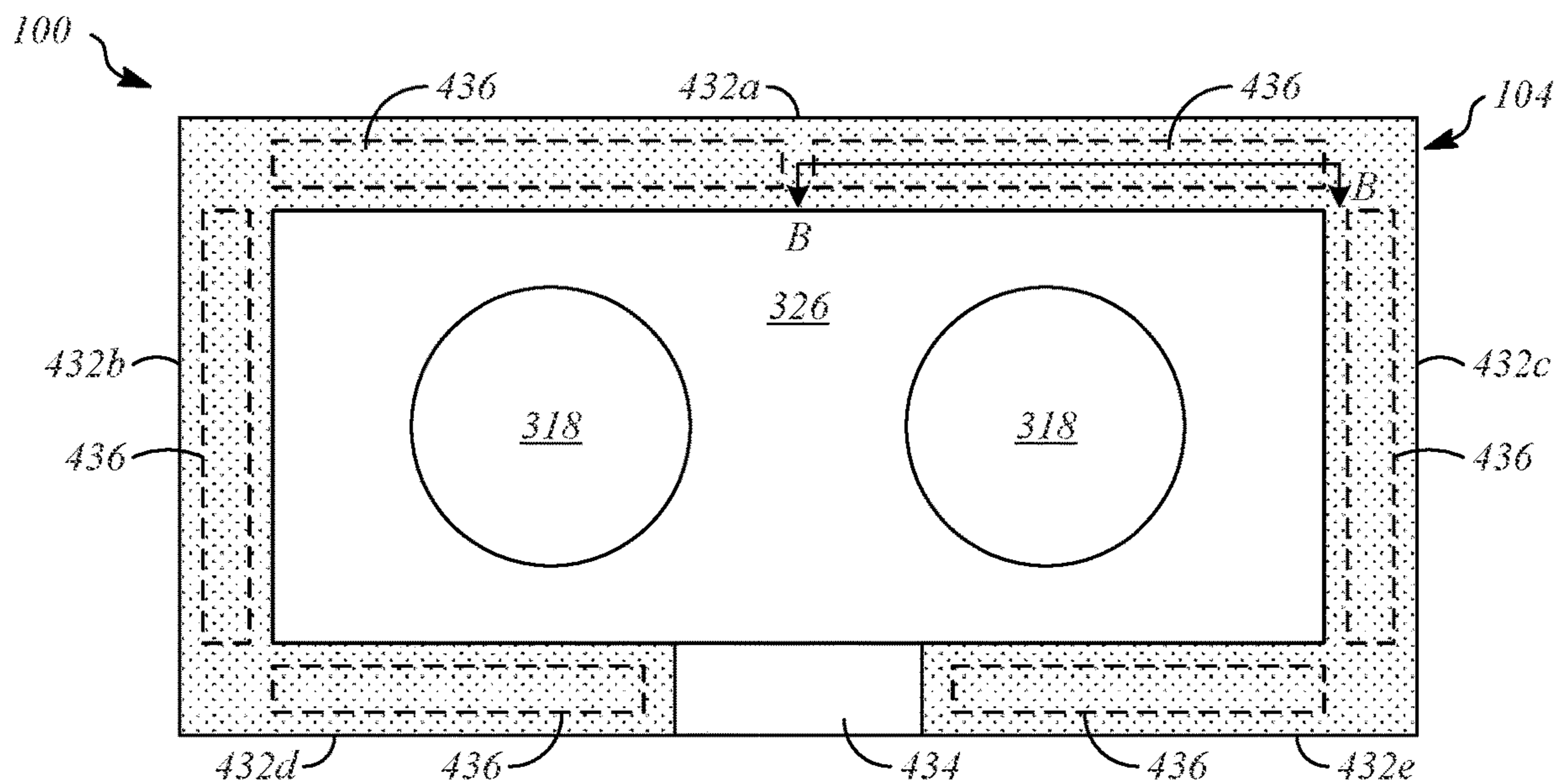

FIG. 4

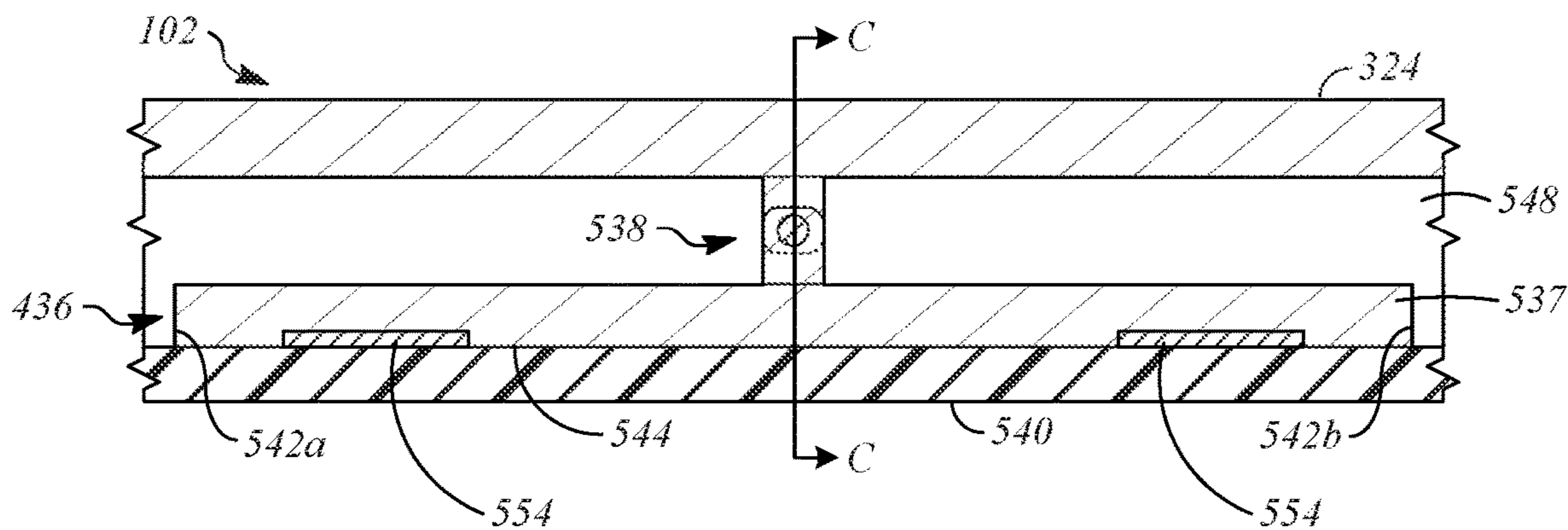

FIG. 5A

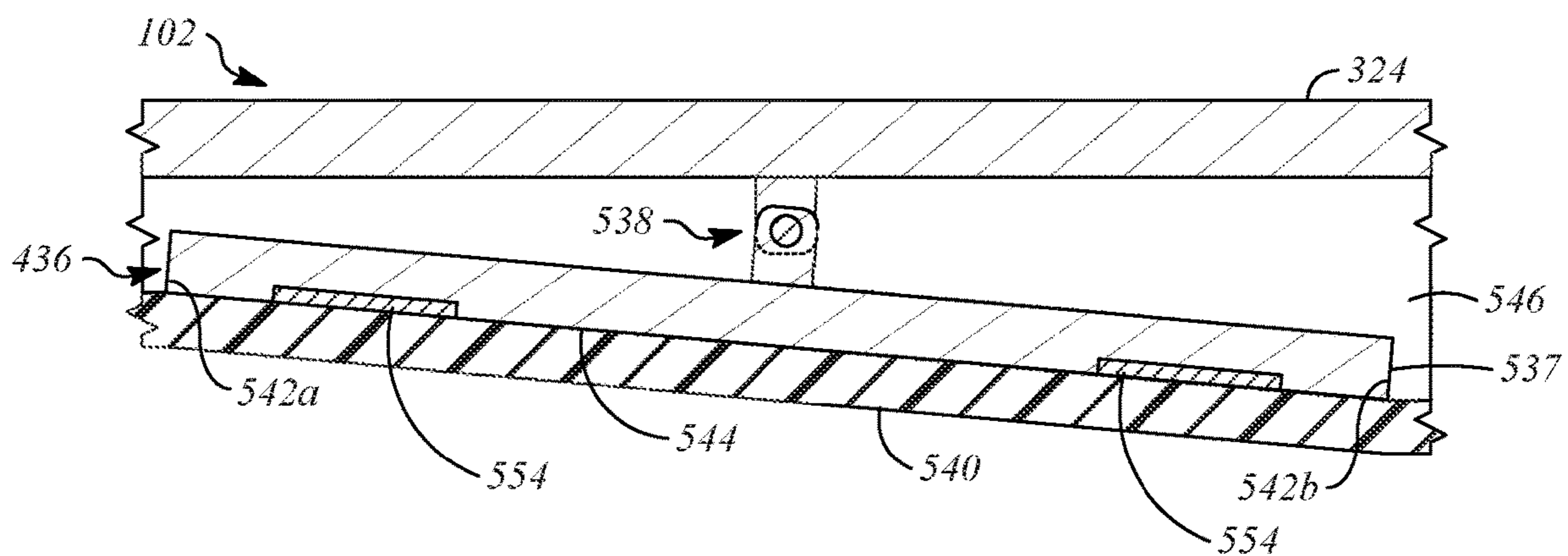

FIG. 5B

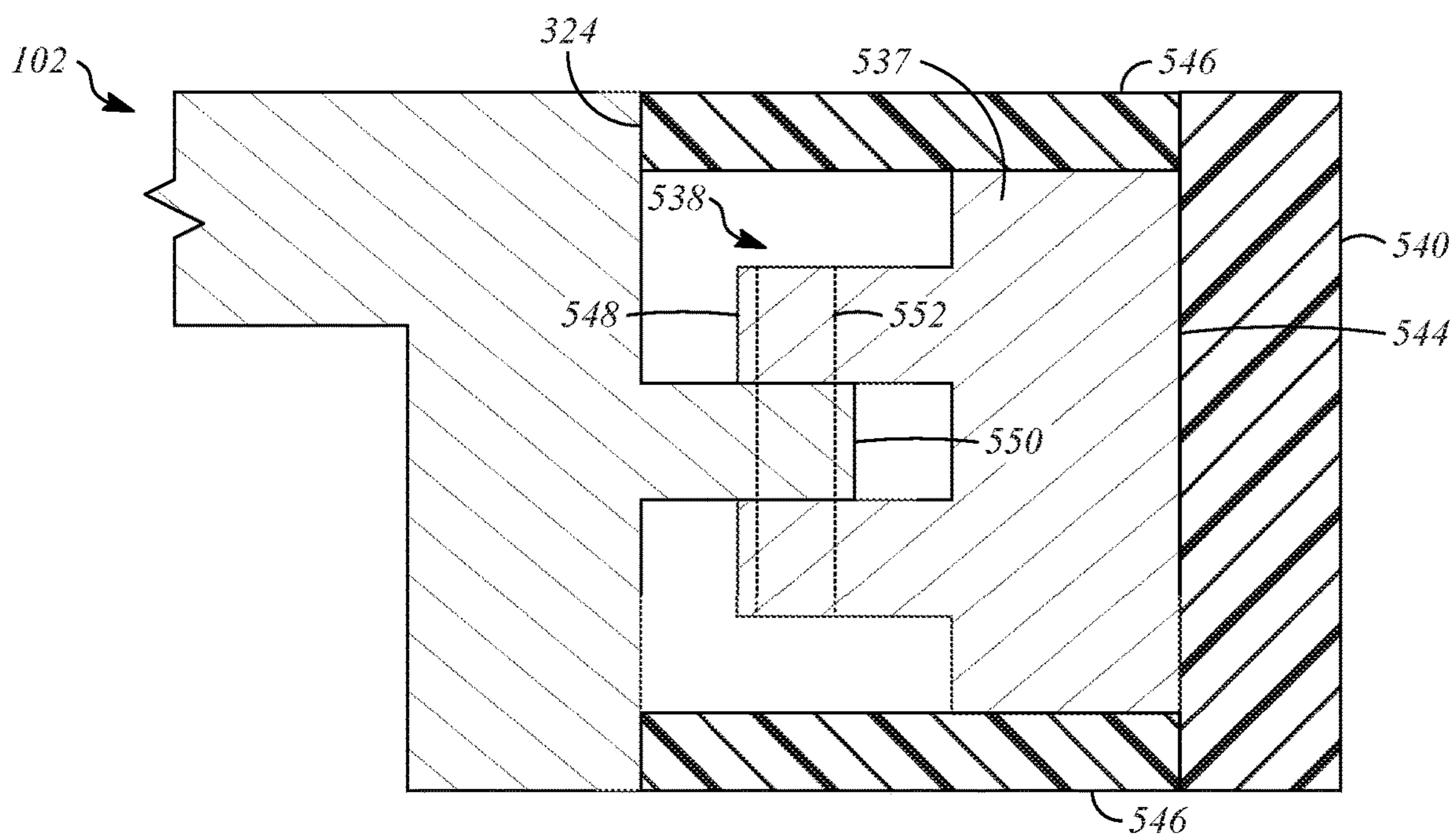

FIG. 5C

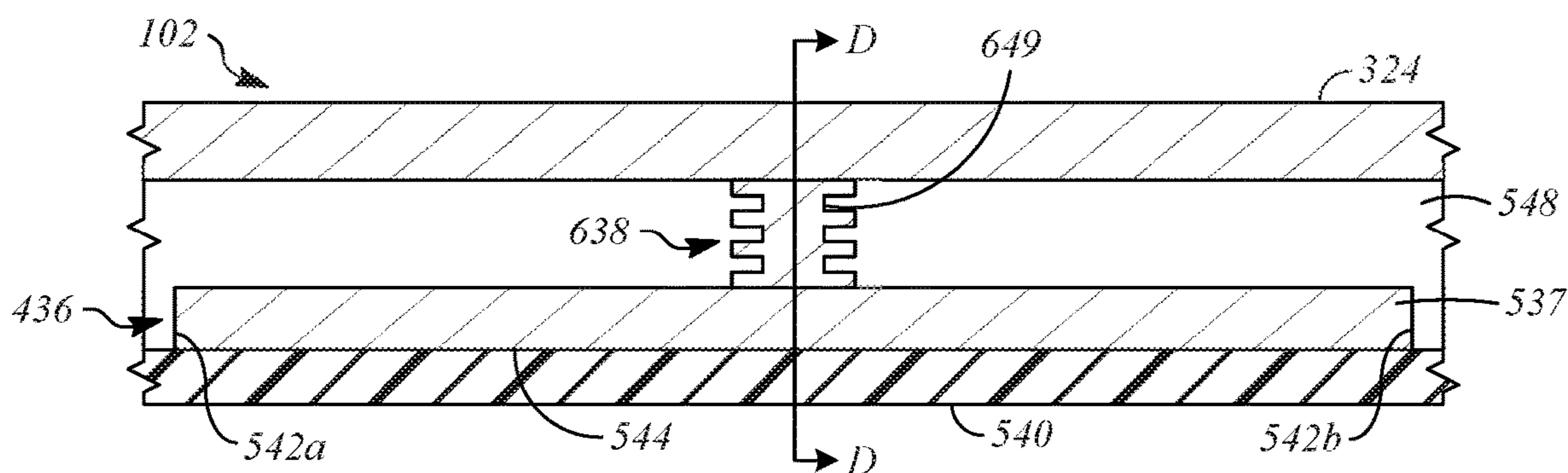

FIG. 6A

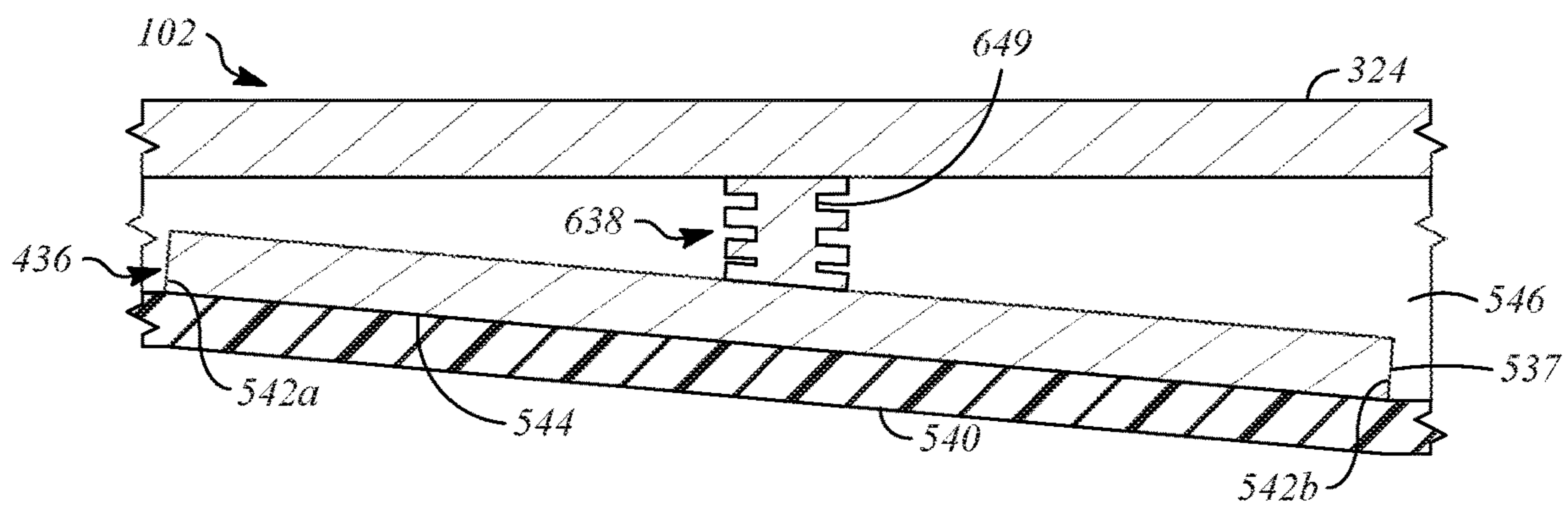

FIG. 6B

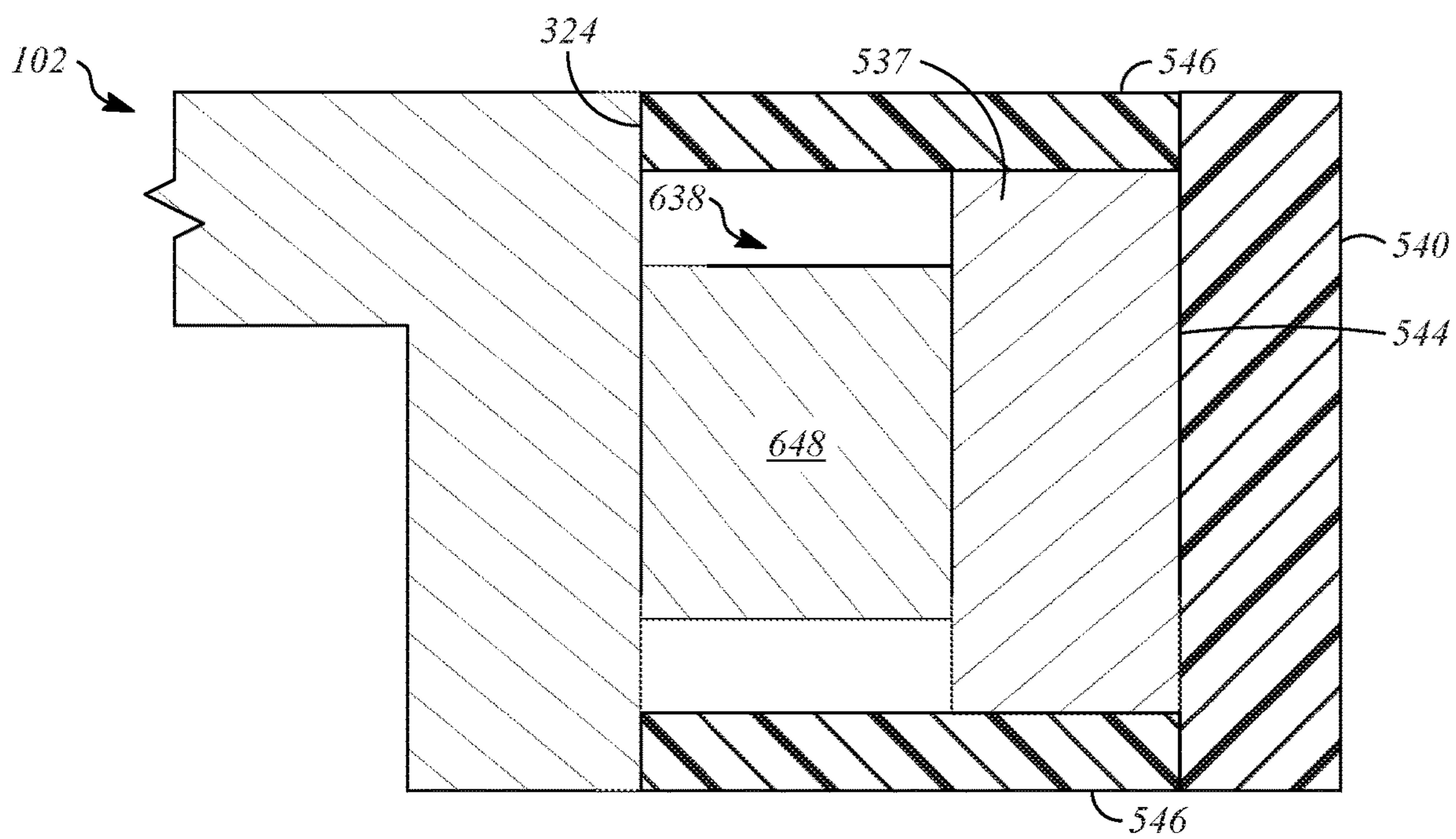

FIG. 6C

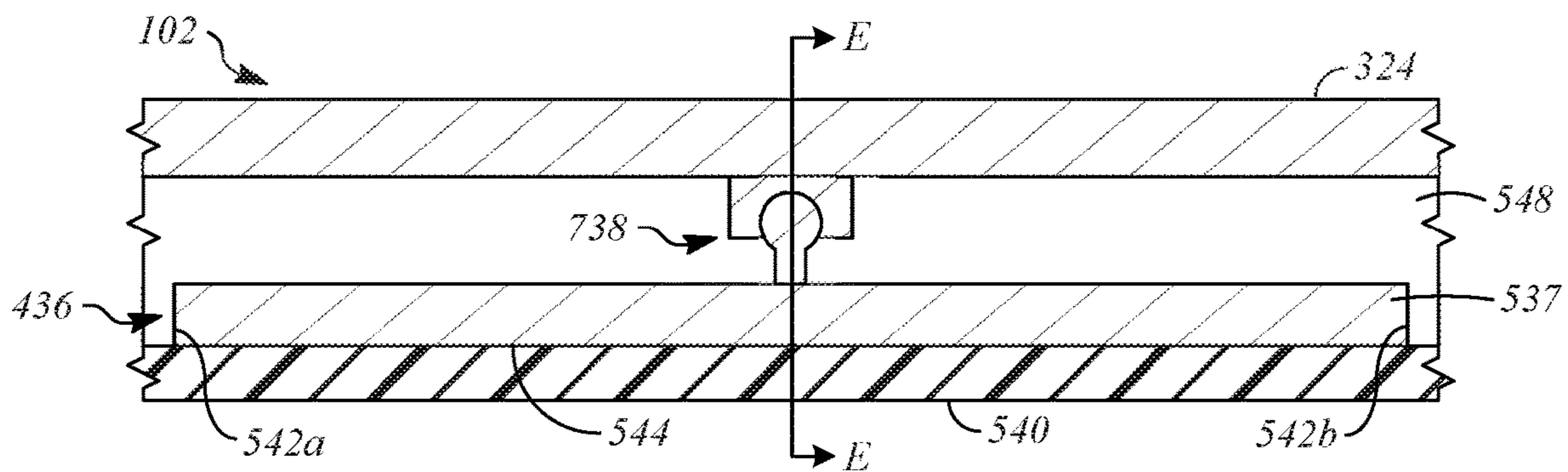

FIG. 7A

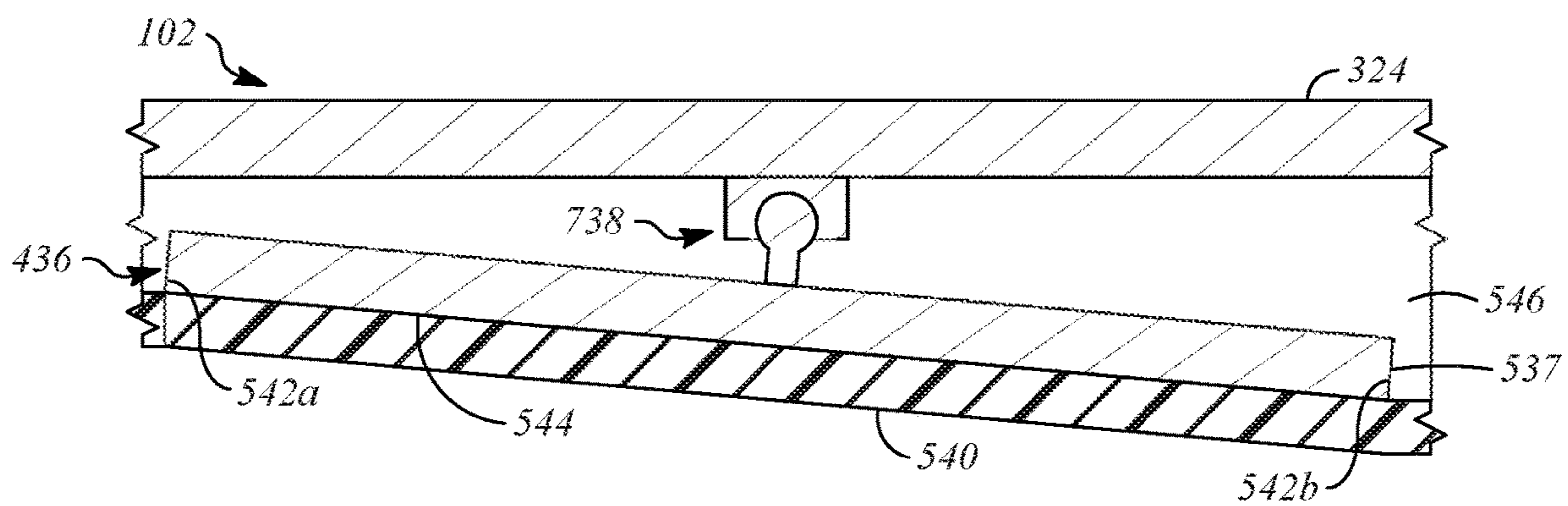

FIG. 7B

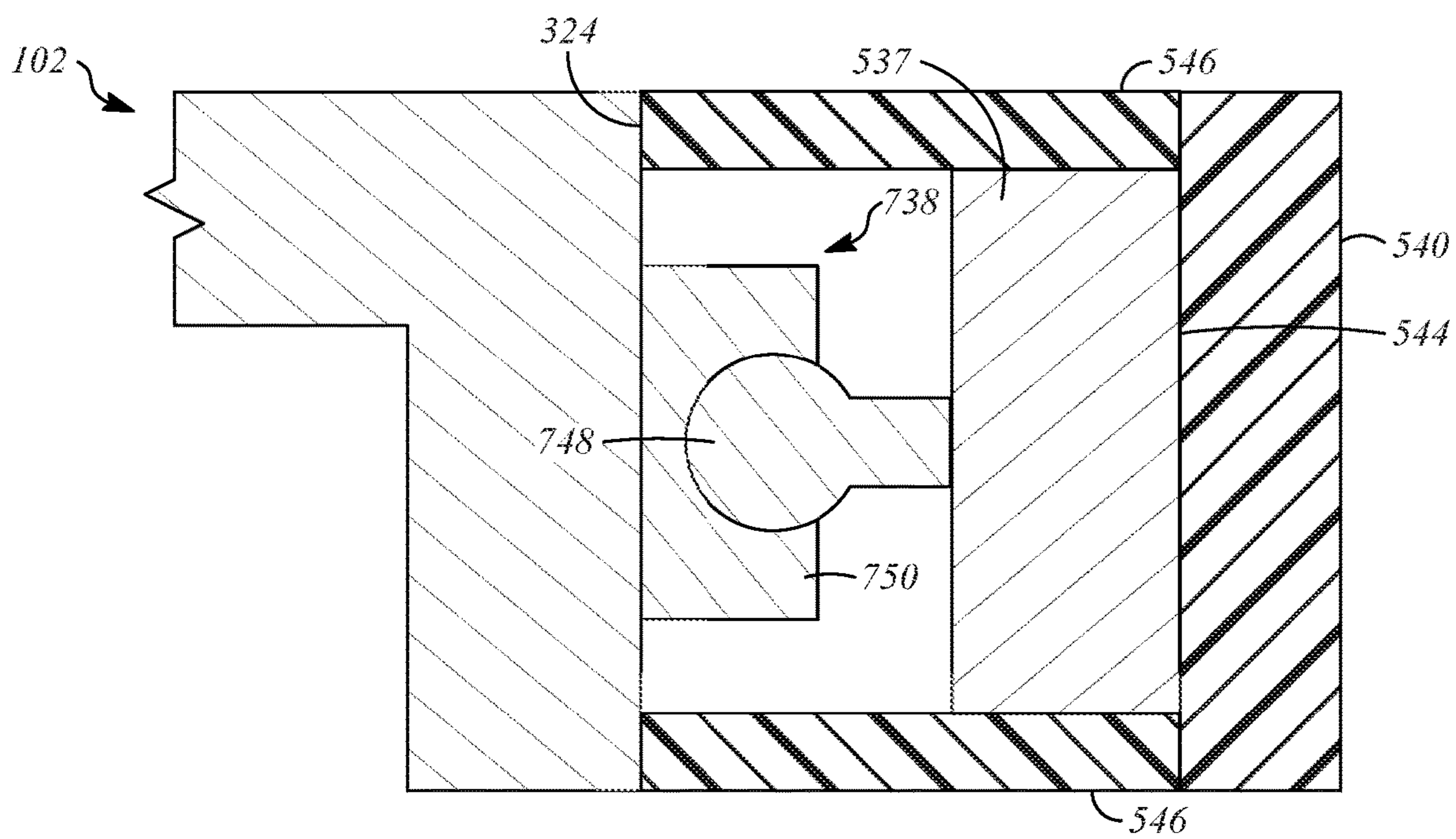

FIG. 7C

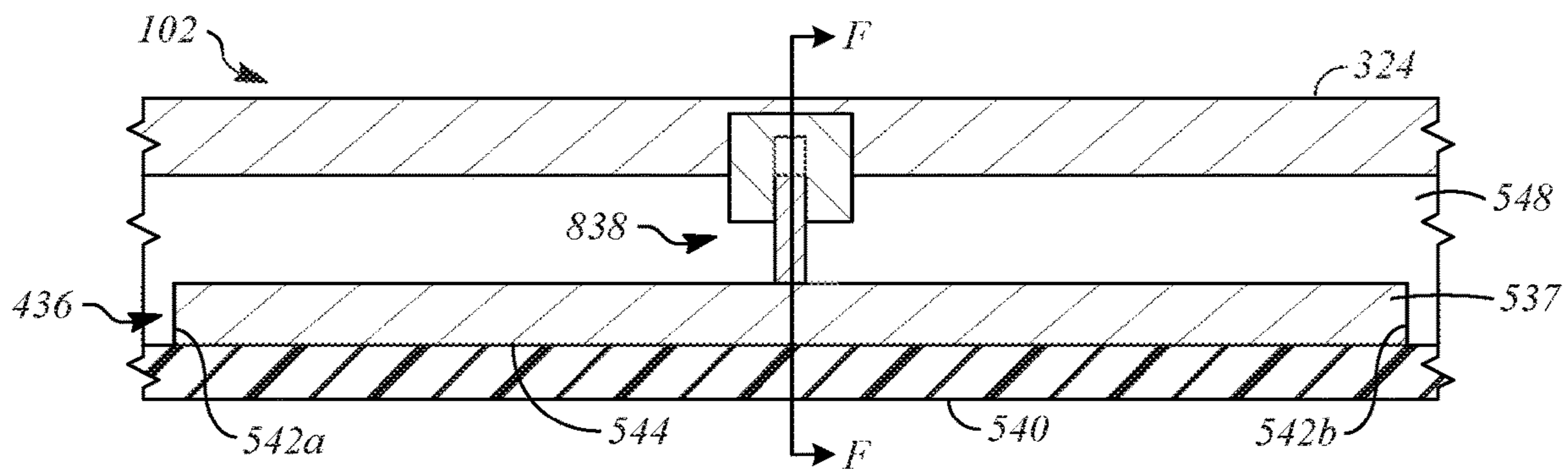

FIG. 8A

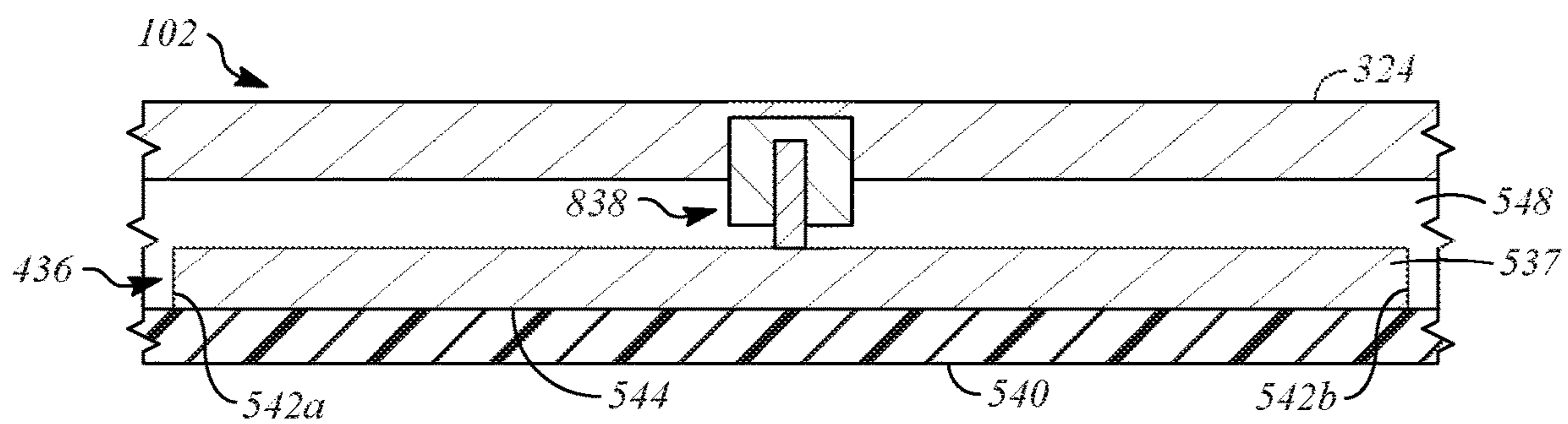

FIG. 8B

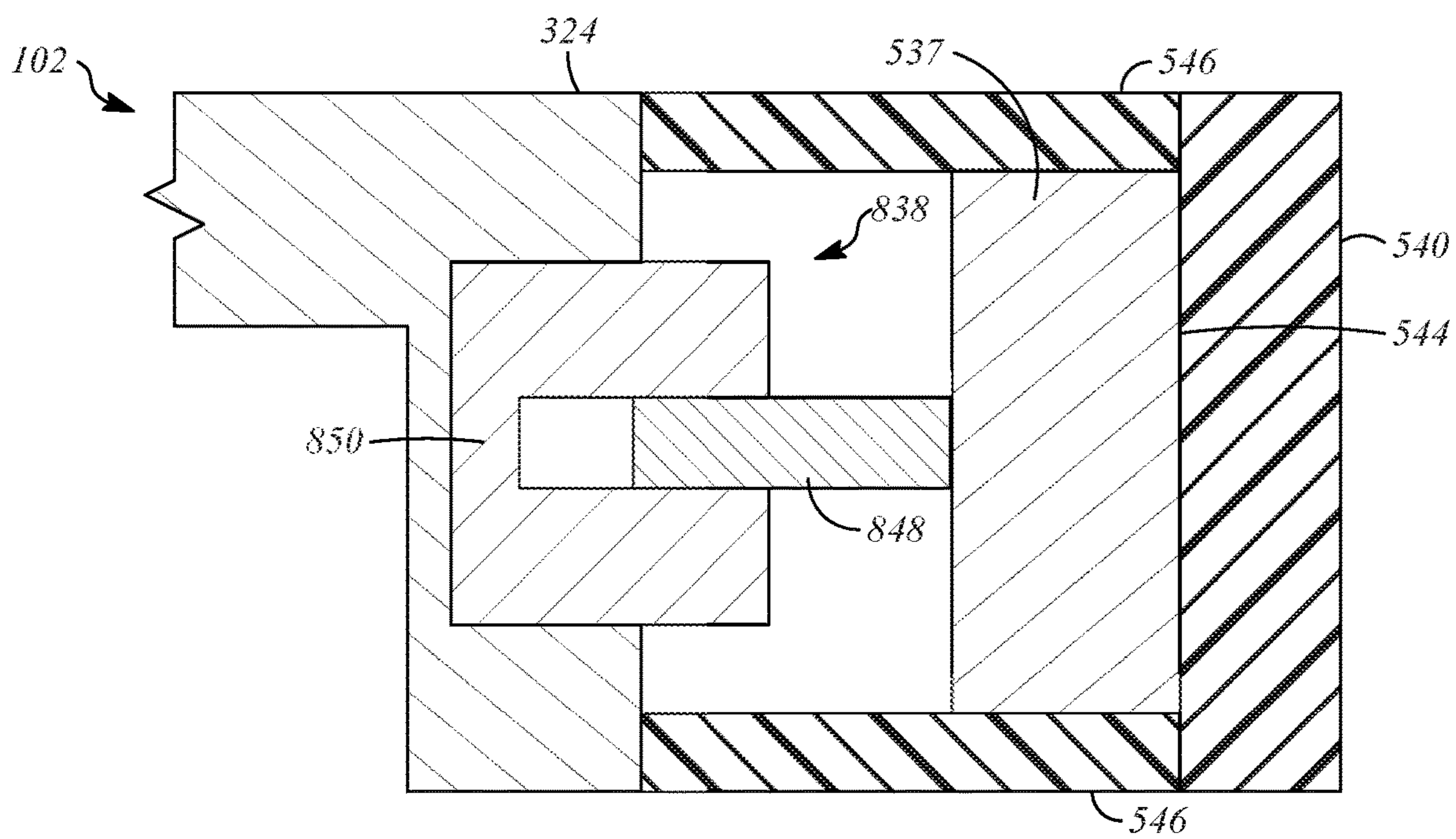

FIG. 8C

322 ↘

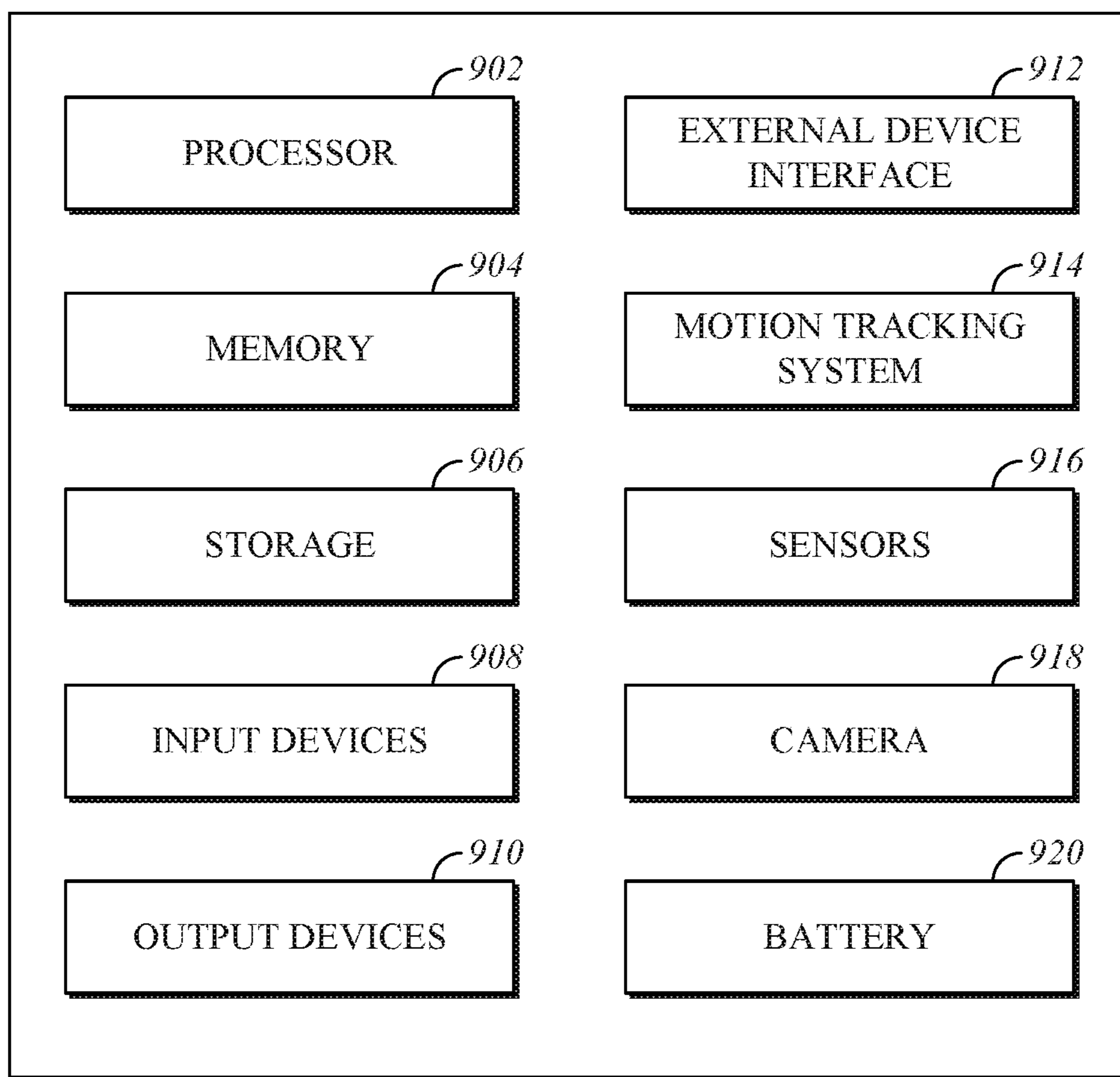

FIG. 9

SENSOR FOR HEAD-MOUNTED DISPLAY

CROSS-REFERENCE TO RELATED APPLICATIONS

[0001] This application is a continuation of U.S. patent application Ser. No. 16/118,504, filed on Aug. 31, 2018, and claims the benefit of U.S. Provisional Application No. 62/558,401, filed on Sep. 14, 2017, the contents of which are hereby incorporated by reference in their entirety for all purposes.

TECHNICAL FIELD

[0002] The application relates generally to sensors for use in head-mounted displays.

BACKGROUND

[0003] Head-mounted displays are devices that are worn on a user's head and incorporate one or more optical display devices. Some head-mounted displays have an open design in which the user's eyes are not shielded from the outside environment. Other head-mounted displays have a closed design that incorporates a face seal. The face seal is a portion of the head-mounted display that contacts the user's face around their eyes to block exterior light. In some designs, the face seal also helps support the head-mounted display relative to the user's head. One typical design for a face seal is a foam structure that contacts the user's forehead and extends around the outer sides of the user's eyes, with a gap or recess present in the area where the user's nose will be positioned.

SUMMARY

[0004] One aspect of the disclosure is a head-mounted display to be worn by a user. The head-mounted display includes a housing, a compressible material, and a support member. The compressible material is connected to the housing and is configured for contact with the user. The support member is disposed in the compressible material. The support member is movably connected to the housing.

[0005] Another aspect of the disclosure is a head-mounted display to be worn by a user. The head-mounted display includes a housing that defines an eye chamber and a peripheral portion that extends around the eye chamber. A first seal support member is connected to the peripheral portion of the housing and defines a first adjustable reaction surface. A second seal support member is connected to the peripheral portion of the housing and defines a second adjustable reaction surface. A face seal covers the first seal support member and the second seal support member.

[0006] Another aspect of the disclosure is a head-mounted display to be worn by a user. The head-mounted display includes a housing and a support member that is connected to the housing. The support member has a front surface. A sensor is located on the front surface of the support member. A compressible material is connected to the front surface of the support member.

BRIEF DESCRIPTION OF THE DRAWINGS

[0007] FIG. 1 is a perspective view illustration showing a head-mounted display.

[0008] FIG. 2A is a side view showing the head-mounted display worn by a user.

[0009] FIG. 2B is a top view showing the head-mounted display worn by the user.

[0010] FIG. 3 is a cross-section view of the head-mounted display taken along line A-A of FIG. 2B.

[0011] FIG. 4 is a front view of the head-mounted display showing the face seal 104.

[0012] FIG. 5A is a cross-section view illustration taken across line B-B of FIG. 4 showing one of the seal support members supported by a first hinge assembly in a first angular orientation.

[0013] FIG. 5B is a cross-section view illustration taken across line B-B of FIG. 4 showing the seal support member of FIG. 5A supported by the first hinge assembly in a second angular orientation.

[0014] FIG. 5C is a cross-section view illustration taken across line C-C of FIG. 5A showing one of the seal support members supported by the first hinge assembly.

[0015] FIG. 6A is a cross-section view illustration taken across line B-B of FIG. 4 showing one of the seal support members supported by a second hinge assembly in a first angular orientation.

[0016] FIG. 6B is a cross-section view illustration taken across line B-B of FIG. 4 showing the seal support member of FIG. 6A supported by the second hinge assembly in a second angular orientation.

[0017] FIG. 6C is a cross-section view illustration taken across line D-D of FIG. 6A showing one of the seal support members supported by the second hinge assembly.

[0018] FIG. 7A is a cross-section view illustration taken across line B-B of FIG. 4 showing one of the seal support members supported by a third hinge assembly in a first angular orientation.

[0019] FIG. 7B is a cross-section view illustration taken across line B-B of FIG. 4 showing the seal support member of FIG. 6A supported by the third hinge assembly in a second angular orientation.

[0020] FIG. 7C is a cross-section view illustration taken across line E-E of FIG. 7A showing one of the seal support members supported by the third hinge assembly.

[0021] FIG. 8A is a cross-section view illustration taken across line B-B of FIG. 4 showing one of the seal support members supported by an adjustment assembly in a first angular orientation.

[0022] FIG. 8B is a cross-section view illustration taken across line B-B of FIG. 4 showing the seal support member of FIG. 6A supported by the adjustment assembly in a second angular orientation.

[0023] FIG. 8C is a cross-section view illustration taken across line F-F of FIG. 8A showing one of the seal support members supported by the adjustment assembly.

[0024] FIG. 9 is a block diagram that shows an example of a hardware configuration for electronic components of the head-mounted display.

DETAILED DESCRIPTION

[0025] The sizes and shapes of user's faces can vary widely. Some conventional face seal designs incorporate thick foam structures that are highly compressed in some areas by contact with the user's face, while remaining uncompressed or lightly compressed in other areas. For some face shapes and sizes, the foam structure may be unable to conform to the user's face, and ability of the foam structure to block light may be compromised. In implementations in which engagement of the face seal with the user's

face is relied upon to support the head-mounted display, some users may experience uncomfortable areas of high pressure.

[0026] The disclosure herein is directed to face seals for head-mounted displays, components that can be incorporated in face seals for head-mounted displays, and components that can be used with face seals for head-mounted displays. The face seal designs disclosed herein include movable structures that conform the face shape of the user in order to enhance comfort and/or light-blocking, which improves the user experience.

[0027] FIG. 1 is a perspective view illustration showing a head-mounted display 100. The head-mounted display includes a housing 102, a face seal 104, and a headband 106. The face seal 104 and the headband 106 are connected to the housing 102. The face seal 104 is configured to engage and conform to the user's head in the area around the user's eyes. The headband 106 is configured to support the housing 102 relative to the user's head. In the illustrated example, the housing 102 is a generally rectangular structure, and headband 106 is a structure such as a strap or a rigid member that connects to the lateral sides of the housing 102 to extend peripherally around a user's head. The housing 102 may be a single-piece structure or may be a multi-piece structure, and is either rigid or semi-rigid. The headband 106 may include adjustment features, such as variable length strap assemblies that are adjusted using fasteners such as buttons, buckles, or hook-and-loop fasteners. The housing 102 and the headband 106 are shown and described to provide context, and it should be understood that the features described herein can be utilized with head-mounted displays that utilize a broad range of configurations. As one example, the headband 106 could include an additional strap that extends over the center of the user's head.

[0028] FIG. 2A is a side view showing the head-mounted display 100 worn by a user 208, and FIG. 2B is a top view showing the head-mounted display 100 worn by the user. The face seal 104 contacts an upper part of the face 210 of the user 208. As an example, the face seal 104 may contact the forehead, the temples, the cheeks, and/or the nose of the user 208, and extend around the eye area 212 of the user 208.

[0029] FIG. 3 is a cross-section view of the head-mounted display 100 taken along line A-A of FIG. 2B. The head-mounted display 100 includes the housing 102, a divider wall 316, lenses 318 (e.g. two lenses that are each paired with one of the user's eyes), one or more display devices 320, and electronic components 322.

[0030] The housing 102 includes an external structure of the head-mounted display 100 and may include parts of an internal structure of the head-mounted display 100. The housing 102 is connected to the headband 106 (FIGS. 1-2B) or other support structure. Internal spaces of the head-mounted display 100 are defined by the housing 102, in order to support and/or enclose portions of the head-mounted display 100 such as the divider wall 316, the lenses 318, the display devices 320, and the electronic components 322. The housing 102 may be a multi-part structure, or may be a single part structure. The housing 102 may be rigid or semi rigid, and with respect to multi-part structures for the housing 102, may include various portions having differing material properties inclusive of rigid portions and flexible portions.

[0031] A front end of the housing 102 includes a peripheral portion 324, which is adjacent to the user 208 when

worn. The peripheral portion 324 extends around part or all of the housing 102 at the front end, and provides a support surface or support structure for the face seal 104. Other components and/or structures may be formed on or supported by the peripheral portion 324, such as sensors.

[0032] The divider wall 316 is positioned inside the housing 102. The divider wall 316 has a first side that is exposed to the exterior, and is adjacent to an eye chamber 326, which is defined within the housing 102 between the divider wall 316 and the face seal 104. When the head-mounted display 100 is worn by the user 208, the eyes of the user 208 are positioned adjacent to the eye chamber 326. By engagement of the face seal 104 with the face 210 of the user 208, the face seal 104 is operable to reduce or eliminate the amount of light from the environment outside the face seal 104 that enters the eye chamber 326.

[0033] The divider wall 316 may support the lenses 318, either directly or indirectly. In the illustrated example, the lenses 318 are connected to the divider wall 316 and are located in apertures 328 that are formed in the divider wall 316. Other implementations of the head-mounted display 100 may connect the lenses 318 to the divider wall 316 indirectly. As one example, the lenses 318 can be supported by an interpupillary distance adjustment mechanism that is operable to move the lenses 318 laterally toward or away from each other. As another example, the lenses 318 can be supported by an eye relief adjustment mechanism that is operable to adjust the position of the lenses 318 in the front-to-rear direction of the housing 102 to change the distance between the eyes of the user 208 and the lenses 318.

[0034] The lenses 318 focus, redirect, and reshape the images from the display devices 320 to achieve a desired focal length and other optical properties. The display devices 320 are located in the housing 102 and are oriented such that they emit light (e.g., in patterns that form images) toward the lenses 318. As examples, the display devices 320 may be LED display panels, OLED display panels, or LCD display panels. In some implementation, the display devices 320 include two display panels that are each associated with one of the lenses 318. In other implementations, the display devices 320 include a single display panel that is associated with both of the lenses 318. The lenses 318 direct the images emitted by the display devices 320 toward the eyes of the user 208 in a manner that simulates the way the light from a three-dimensional environment reaches the eyes of the user 208. As one example, the lenses 318 may be biconvex lenses. As another example, the lenses 318 may be Fresnel lenses. Focal lengths for the lenses 318 may be, for example, between 25 mm and 50 mm.

[0035] On a second side of the divider wall 316, opposite the eye chamber 326, an internal chamber 330 is formed between the divider wall 316 and the housing 102. In some implementations, multiple internal chambers are present. In the illustrated example, the display devices 320 and the electronic components 322 are located in the internal chamber. The display devices 320 may be supported by the divider wall 316 (as illustrated), by the housing 102, or by other structures that are located in the internal chamber 330.

[0036] The electronic components 322 are located in the internal chamber 330 and may be supported by the housing 102 or by other structures that are present in the internal chamber 330. The electronic components 322 are connected to the display devices 320 and includes components that generate or receive content, in the form of signals or data,

that are provided by the display devices to be output for display by the display devices 320 as images defined by emitted light. The electronic components 322 may also include sensors that detect conditions that are relevant to operation of the head-mounted display 100, such as the position and orientation of the head-mounted display 100.

[0037] FIG. 4 is a front view of the head-mounted display 100 showing the face seal 104. The face seal 104 includes an upper portion 432a, a left portion 432b, a right portion 432c, a lower-left portion 432d, and a lower-right portion 432e. The upper portion 432a is located on the peripheral portion 324 of the housing 102 adjacent to an upper surface of the housing 102. The left portion 432b is located on the peripheral portion 324 of the housing 102 adjacent to a left-side surface of the housing 102. The right portion 432c is located on the peripheral portion 324 of the housing 102 adjacent to a right-side surface of the housing 102. The lower-left portion 432d is located on the peripheral portion 324 of the housing 102 adjacent to a lower surface of the housing 102 and to the left side of a nose-relief area 434 that is formed on the housing 102 to provide space for the nose of the user 208. The lower-right portion 432e is located on the peripheral portion 324 of the housing 102 adjacent to a lower surface of the housing 102 and to the right side of the nose-relief area 434.

[0038] The face seal 104 is supported by one or more seal support members 436 that are each connected to the housing 102 in a manner that allows motion of each seal support member 436 relative to the housing 102. In the illustrated example, the seal support members 436 are independent elements that are incorporated in the face seal 104 in each of the upper portion 432a, the left portion 432b, the right portion 432c, the lower-left portion 432d, and the lower-right portion 432e. In other implementations, different numbers of the seal support members 436 are provided and different locations for the seal support members are provided. For example, the face seal 104 could incorporate two of the seal support members 436, such as a first seal support member positioned at the left side of the upper portion 432a and a second seal support member positioned at the right side of the upper portion 432a.

[0039] The face seal 104 is formed from a resilient compressible material that compresses in response to engagement with the face of the user 208, and expands when engagement ceases. Examples of resilient compressible materials that can be used for the face seal 104 include synthetic rubber, closed cell foam materials, and open cell foam materials. The seal support members 436 are embedded in or under the resilient compressible material of the face seal 104 to limit the degree of compression of the face seal 104.

[0040] The seal support members 436 conform to the geometry of the face of the user 208 relative to the housing 102 by moving, such as by rotation around an axis. Movement of the seal support members 436 disposes a fixed amount of the face seal 104 between the seal support members 436 and the user 208. Thus, by conforming to the geometry of the face of the user 208, users having various face shapes and head shapes can comfortably use the head-mounted display 100.

[0041] FIGS. 5A-5C show one of the seal support members 436 from the upper portion 432a of the face seal 104. In particular, FIG. 5A is a cross-section view illustration taken across line B-B of FIG. 4 showing the seal support

member 436 in a first angular orientation, FIG. 5B is a cross-section view illustration taken across line B-B of FIG. 4 showing the seal support member 436 in a second angular orientation, and FIG. 5C is a cross-section view illustration taken across line C-C of FIG. 5A showing the seal support member 436 in the first angular orientation.

[0042] The seal support member 436 includes a primary portion 537 that supports a front portion 540 of the face seal 104. The primary portion 537 of the seal support member 436 provides support for the face seal 104 and provides a reaction surface against which the face seal 104 can be compressed. The primary portion 537 is not compressible, and may be formed from an incompressible material that is rigid or substantially rigid. As an example, the primary portion 537 may be formed from plastic.

[0043] The face seal 104 is an elongate member, and may extend from a first end 542a to a second end 542b. As installed in the upper portion 432a, the primary portion 537 is elongate in the lateral direction of the housing 102. If installed in other locations, such as in the right portion 432c of the face seal 104, the seal support member 436 would be oriented to conform to that portion of the face seal 104, and could be vertically elongate. The primary portion 537 can be configured to conform to the shape of the face seal 104 and thus can be, as examples, straight or curved.

[0044] The seal support member 436 is connected to the peripheral portion 324 of the housing 102 by a hinge assembly 538. The hinge assembly 538 allows the seal support member 436 to move and thereby conform to the user 208. In the illustrated example, the hinge assembly 538 is positioned at or near the lateral center point of the seal support member 436, between the first end 542a and the second end 542b. Other locations can be utilized. As an example, the hinge assembly 538 could be positioned at or near the first end 542a or the second end 542b of the seal support member 436.

[0045] In the illustrated example, the hinge assembly 538 allows rotation on a single axis, such as an axis that extends generally in an up-and-down direction relative to the housing 102. This allows for face shape accommodation in the area of the forehead of the user 208, to allow for differing head widths and differing degrees of roundness, by angling adjacent ones of the seal support members 436 at smaller angles relative to each other to accommodate smaller head sizes, and at larger angles relative to each other to accommodate larger head sizes. With respect to installation of the seal support member 436 at other locations, such as in the right portion 432c of the face seal 104, the hinge assembly 538 would be oriented to allow rotation along an axis that extends generally in a side-to-side direction. Other orientations could be utilized.

[0046] As described above, the hinge assembly 538 is a passive component. In an alternative implementation, the hinge assembly 538 may include a controllable actuator to actively adjust the seal support member 436 or to apply tactile feedback.

[0047] The front portion 540 of the face seal 104 is located on and covers a front surface 544 of the seal support member 436. The front portion 540 of the face seal 104 may be positioned adjacent to the front surface 544 of the seal support member 436, but without attachment to the seal support member 436. Alternatively, the front portion 540 of

the face seal **104** may be connected to the front surface **544** of the seal support member **436**, such as by adhesives or by mechanical fasteners.

[0048] The face seal **104** may also include connecting portions **546** that extend from the front portion **540** of the face seal **104** to the housing **102**. The connecting portions **546** can be engaged with and/or connected to the peripheral portion **324** of the housing **102**. The connecting portions **546** function to block ambient light from entering the eye chamber **326**, and can be formed from an opaque material to help block transmission of light. The connecting portions **546** may be formed both on an outer periphery of the face seal **104** (i.e., adjacent to the outer surface of the housing **102**) and on an inner periphery of the face seal **104** (i.e., adjacent to the eye chamber **326**).

[0049] The connecting portions **546** may be formed from a flexible material to allow compression and expansion during movement of the seal support member **436**. In one implementation, the connecting portions **546** are formed from the same material as the front portion **540** of the face seal **104** and these portions may be formed as an integral structure. In another implementation, the connecting portions **546** are formed from a flexible material that is more flexible and/or more compressible than the material used for the front portion **540** of the face seal **104**. In another implementation, the connecting portions **546** are formed from a synthetic rubber material, and may include a bellows configuration.

[0050] As best seen in FIG. **5C**, the hinge assembly **538** includes a first hinge part **548** that extends outward from a rear surface of the seal support member **436**, and a second hinge part **550** that extends outward from the peripheral portion **324** of the housing **102**. In the illustrated example of the first hinge part **548** and the second hinge part **550** are overlapping and/or interlocking structures (e.g., alternating plates) that are connected by a pin **552** that extends through apertures in the first hinge part **548** and the second hinge part **550** along the rotation axis of the seal support member **436**. The pin **552** can be formed separately from the first hinge part **548** and the second hinge part **550** or can be an integrally formed projection located on one of the first hinge part **548** or the second hinge part **550**. In other implementations, the hinge assembly **538** can utilize other known designs, such as a linkage (e.g., a four-bar linkage).

[0051] The hinge assembly **538** can incorporate structures that bias the hinge assembly in a direction of rotation or toward a centered position. Examples of suitable biasing structures include springs and compressible members, (e.g., rubber or foam) that is placed between the seal support member **436** and the peripheral portion **324** of the housing **102**.

[0052] In some implementations, sensors **554** can be incorporated in the face seal **104**. The sensors **554** are located on or adjacent to the front surface **544** of the seal support member **436**, which maintains a consistent distance between the skin of the user **208** and the sensors **554**, to allow information regarding the user to be sensed accurately. As one example, the sensors **554** can measure skin temperature. As another example, the sensors **554** can measure heart rate. Other types of sensors that measure other characteristics can be included.

[0053] FIGS. **6A-6C** show the seal support member **436** supported by a hinge assembly **638** according to an alternative implementation. In particular, FIG. **6A** is a cross-

section view illustration taken across line B-B of FIG. **4** showing the seal support member **436** and the hinge assembly **638** in a first angular orientation, FIG. **6B** is a cross-section view illustration taken across line B-B of FIG. **4** showing the seal support member **436** and the hinge assembly **638** in a second angular orientation, and FIG. **6C** is a cross-section view illustration taken across line D-D of FIG. **6A** showing the seal support member **436** and the hinge assembly **638** in the first angular orientation.

[0054] The hinge assembly **638** is a living hinge type connection, which in the illustrated example, allows rotation around an upright axis similar to the hinge assembly **538**. The hinge assembly **638** includes a hinge member **648**, which may be formed of the same material and/or may be formed integrally with the seal support member **436**. Alternatively, the hinge member **648** may be separately formed from a different more flexible material than the seal support member **436**. In the illustrated example, upright grooves **649** are formed on side surfaces of the hinge member **648** to enhance side-to-side bending over a desired angular range.

[0055] FIGS. **7A-7C** show the seal support member **436** supported by a hinge assembly **738** according to an alternative implementation. In particular, FIG. **7A** is a cross-section view illustration taken across line B-B of FIG. **4** showing the seal support member **436** and the hinge assembly **738** in a first angular orientation, FIG. **7B** is a cross-section view illustration taken across line B-B of FIG. **4** showing the seal support member **436** and the hinge assembly **738** in a second angular orientation, and FIG. **7C** is a cross-section view illustration taken across line E-E of FIG. **7A** showing the seal support member **436** and the hinge assembly **738** in the first angular orientation.

[0056] The hinge assembly **738** includes a ball and socket type joint that allows three-axis rotation, subject to range-of-motion constraints placed on motion of seal support member **436** by engagement with the face seal **104**. In the illustrated example a ball joint **748** is connected to a rear surface of the primary portion **537** of the seal support member **436**, and a socket joint **750** is connected to and extends forward from the peripheral portion **324** of the housing **102**. Alternatively, the positions of the ball joint **748** and the socket joint **750** can be reversed.

[0057] FIGS. **8A-8C** show the seal support member **436** supported by an adjustment assembly **838** according to an alternative implementation. In particular, FIG. **8A** is a cross-section view illustration taken across line B-B of FIG. **4** showing the seal support member **436** and the adjustment assembly **838** in a first position, FIG. **8B** is a cross-section view illustration taken across line B-B of FIG. **4** showing the seal support member **436** and the adjustment assembly **838** in a second position, and FIG. **8C** is a cross-section view illustration taken across line F-F of FIG. **8A** showing the seal support member **436** and the adjustment assembly **838** the first position.

[0058] The adjustment assembly **838** includes first portion **848** that is connected to the seal support member **436** and a second portion **850** that is connected to the peripheral portion **324** of the housing **102**. The first portion **848** may be an elongate member such as a rod. The second portion **850** is connected to the first portion **848** in a manner that allows axial motion of the first portion **848** relative to the second portion **850**. The second portion **850** may be a receptacle, such as an opening that the first portion **848** is received in the second portion **850**.

[0059] Movement of the first portion **848** into and out of the second portion **850** changes the distance between the seal support member **436** and the peripheral portion **324** of the housing **102**, in order to accommodate the face shape of the user **208** and/or to adjust the fit of the head-mounted display **100** on the head of the user **208**. As in the illustrated example, the adjustment assembly **838** may allow movement linearly (i.e., by translation) between the first position (FIG. **8A**) and the second position (FIG. **8B**). The first position may represent a maximum distance of the seal support member **436** from the peripheral portion **324** of the housing **102**, and the second position may represent a minimum distance of the seal support member **436** from the peripheral portion **324** of the housing **102**.

[0060] The adjustment assembly **838** may include either or both of passive adjustment components and active adjustment components. One example of a passive adjustment mechanism is a spring that is located in the second portion **850** to urge the first portion **848** outward, and allow inward movement of the seal support member **436** in response to engagement with the user **208**. One example of an active adjustment mechanism is an electromechanical linear actuator (e.g., a lead screw). In implementations of the adjustment assembly **838** that include active adjustment components, adjustment of the fit of the seal support members **436** can be controlled by a computing device, such as by the electronic components **322**, and can be performed using inputs from the sensors **554** and/or other sensors such as temperature sensors or pressure sensors. In some implementations, active adjustment components may also be used to provide tactile feedback to the user **208**, for example, in the form of pressure or vibrations, where the tactile feedback is related to the content that is shown on the display devices **320**. In some implementations, active components of the adjustment assembly **838** are utilized to provide eye relief adjustment.

[0061] In some implementations, the adjustment assembly **838** is used in combination with a rotational adjustment mechanism, such as the hinge assembly **538**, the hinge assembly **638**, the hinge assembly **738**, or an active rotation adjustment mechanism that utilizes, for example, motors operable to adjust a rotational orientation in response to a control signal.

[0062] The implementations discussed above include the face seal **104**, which is configured to reduce or exclude light from the eye chamber **326**. In alternative implementations, the seal support members **436** are not disposed under the face seal **104**, and light is not excluded from the eye chamber **326**. Instead, the seal support members **436** may be spaced from the housing **102** by an air gap, and cushioning pads such as foam or rubber members can be placed on the front surfaces **544** of the seal support members **436**.

[0063] FIG. **9** is a block diagram that shows an example of a hardware configuration for the electronic components **322** of the head-mounted display **100**. In the illustrated example, the electronic components **322** include a processor **902**, memory **904**, storage **906**, input devices **908**, output devices **910**, an external device interface **912**, a motion tracking system **914**, sensors **916**, a camera **918**, and a battery **920**.

[0064] The processor **902** is operable to execute computer program instructions and perform operations described by the computer program instructions. As an example, the processor **902** may be a conventional device such as a central processing unit. The memory **904** may be a volatile, high-speed, short-term information storage device such as a

random-access memory module. The storage **906** may be a non-volatile information storage device such as a hard drive or a solid-state drive. The input devices **908** may include any type of human-machine interface such as buttons, switches, motion sensitive controllers, a keyboard, a mouse, a touch-screen input device, a gestural input device, or an audio input device (e.g., a microphone). The output devices **910** may include any type of device operable to provide an indication to a user regarding an operating state, such as the display devices **320** or an audio output device (e.g., speakers).

[0065] The external device interface **912** is a wired or wireless interface using any type of protocol. As one example, the external device interface **912** may include a wired connection to an external computing device that is utilized to generate content that is displayed by the display devices **320**, such as by rendering content to be shown using the display devices **320**. As another example, the external device interface **912** can allow wireless connection to internet access to utilize server-based resources during operation of the head-mounted display **100**.

[0066] The motion tracking system **914** can detect three axis rotations and accelerations of the head-mounted display **100**, and provide this information as inputs to the processor **902** or to other systems. As an example, information output by the motion tracking system **914** can be utilized to implement view tracking in certain software applications, and the information output by the motion tracking system **914** can be used by the software application during generation of content to be output for display by the display devices **320**. The motion tracking system **914** can include, for example, an inertial measuring unit that utilizes accelerometers, gyroscopes, and magnetometers to output information that describes motion. The motions tracking system can also include other types of motion tracking technologies, such as structured-light stereo devices, depth cameras, LIDAR devices, radar devices, ultrasonic devices, infrared detectors that measure signals from external infrared sources, and infrared beacons that emit signals that can be measured by external infrared detectors.

[0067] The sensors **916** various types of sensors in addition to those in the motion tracking system. Examples include biometric sensors, temperature sensors, light sensors and force sensors. The camera **918**, which can include a single camera or multiple cameras, can be included to capture video of the environment surrounding the head-mounted display **100** or can be used to sense features in the environment or features of the user. As one example, the camera **918** can be mounted in the eye chamber **326** and used for eye tracking.

[0068] The battery **920** supplies electrical power to various components of the head-mounted display **100**, including the electronic components **322**. As an example, the battery **920** can be a rechargeable battery of any suitable type.

[0069] As described above, one aspect of the present technology is the gathering and use of data available from various sources to improve fit of the face seal of a head-mounted device. The present disclosure contemplates that in some instances, this gathered data may include personal information data that uniquely identifies or can be used to contact or locate a specific person. Such personal information data can include demographic data, location-based data, telephone numbers, email addresses, twitter ID's, home addresses, data or records relating to a user's health or level

of fitness (e.g., vital signs measurements, medication information, exercise information), date of birth, or any other identifying or personal information.

[0070] The present disclosure recognizes that the use of such personal information data, in the present technology, can be used to the benefit of users. For example, the personal information data can be used to adjust the positions and contours of the face seal based on stored user profiles. Further, other uses for personal information data that benefit the user are also contemplated by the present disclosure. For instance, health and fitness data may be used to provide insights into a user's general wellness, or may be used as positive feedback to individuals using technology to pursue wellness goals.

[0071] The present disclosure contemplates that the entities responsible for the collection, analysis, disclosure, transfer, storage, or other use of such personal information data will comply with well-established privacy policies and/or privacy practices. In particular, such entities should implement and consistently use privacy policies and practices that are generally recognized as meeting or exceeding industry or governmental requirements for maintaining personal information data private and secure. Such policies should be easily accessible by users, and should be updated as the collection and/or use of data changes. Personal information from users should be collected for legitimate and reasonable uses of the entity and not shared or sold outside of those legitimate uses. Further, such collection/sharing should occur after receiving the informed consent of the users. Additionally, such entities should consider taking any needed steps for safeguarding and securing access to such personal information data and ensuring that others with access to the personal information data adhere to their privacy policies and procedures. Further, such entities can subject themselves to evaluation by third parties to certify their adherence to widely accepted privacy policies and practices. In addition, policies and practices should be adapted for the particular types of personal information data being collected and/or accessed and adapted to applicable laws and standards, including jurisdiction-specific considerations. For instance, in the US, collection of or access to certain health data may be governed by federal and/or state laws, such as the Health Insurance Portability and Accountability Act (HIPAA); whereas health data in other countries may be subject to other regulations and policies and should be handled accordingly. Hence different privacy practices should be maintained for different personal data types in each country.

[0072] Despite the foregoing, the present disclosure also contemplates embodiments in which users selectively block the use of, or access to, personal information data. That is, the present disclosure contemplates that hardware and/or software elements can be provided to prevent or block access to such personal information data. For example, in the case of head-mounted device adjustment, the present technology can be configured to allow users to select to "opt in" or "opt out" of participation in the collection of personal information data during registration for services or anytime thereafter. In addition to providing "opt in" and "opt out" options, the present disclosure contemplates providing notifications relating to the access or use of personal information. For instance, a user may be notified upon downloading

an app that their personal information data will be accessed and then reminded again just before personal information data is accessed by the app.

[0073] Moreover, it is the intent of the present disclosure that personal information data should be managed and handled in a way to minimize risks of unintentional or unauthorized access or use. Risk can be minimized by limiting the collection of data and deleting data once it is no longer needed. In addition, and when applicable, including in certain health related applications, data de-identification can be used to protect a user's privacy. De-identification may be facilitated, when appropriate, by removing specific identifiers (e.g., date of birth, etc.), controlling the amount or specificity of data stored (e.g., collecting location data a city level rather than at an address level), controlling how data is stored (e.g., aggregating data across users), and/or other methods.

[0074] Therefore, although the present disclosure broadly covers use of personal information data to implement one or more various disclosed embodiments, the present disclosure also contemplates that the various embodiments can also be implemented without the need for accessing such personal information data. That is, the various embodiments of the present technology are not rendered inoperable due to the lack of all or a portion of such personal information data. For example, the face deal of the head mounted device can be adjusted using contemporaneously obtained information that is not stored.

What is claimed is:

1. A head-mounted display, comprising:
 - a housing;
 - a support member connected to the housing and configured to support a compressible material; and
 - a sensor located on the support member.
2. The head-mounted display of claim 1, wherein the sensor is located on a front surface of the support member.
3. The head-mounted display of claim 1, wherein the sensor is configured to measure a characteristic of a user.
4. The head-mounted display of claim 1, wherein the sensor is configured to measure a skin temperature of the user.
5. The head-mounted display of claim 1, wherein the sensor is configured to measure a heart rate of the user.
6. The head-mounted display of claim 1, wherein the support member defines a surface against which the compressible material can be compressed.
7. The head-mounted display of claim 1, wherein the support member is adjustable relative to the housing.
8. The head-mounted display of claim 1, wherein the support member is movable with respect to the housing.
9. The head-mounted display of claim 1, wherein the support member is connected to the housing by a hinge.
10. The head-mounted display of claim 1, wherein the support member is connected to the housing by a living hinge that is formed integrally with the support member.
11. A head-mounted display, comprising:
 - a housing;
 - a support member connected to the housing and configured to move relative to the housing, the support member having a front surface;
 - a sensor located on the front surface of the support member and configured to measure a characteristic of a user; and

a compressible material configured to be compressed against the front surface of the support member.

12. The head-mounted display of claim **11**, wherein the sensor is configured to measure a skin temperature of the user.

13. The head-mounted display of claim **11**, wherein the sensor is configured to measure a heart rate of the user.

14. The head-mounted display of claim **11**, wherein the support member is formed from an incompressible material.

15. A head-mounted display, comprising:

a housing;

a support member connected to the housing and configured to move relative to the housing, the support member defining a front surface;

a sensor located of the front surface of the support member and configured to measure a characteristic of a user; and

a face seal configured to be disposed between the front surface of the support member and the user.

16. The head-mounted display of claim **15**, further comprising:

a hinge, wherein the support member is connected to the housing by the hinge.

17. The head-mounted display of claim **16**, wherein the hinge is a living hinge.

18. The head-mounted display of claim **16**, wherein the hinge assembly includes a first hinge part that is connected to a second hinge part by a pin.

19. The head-mounted display of claim **16**, wherein the hinge assembly includes a ball and socket joint.

20. The head-mounted display of claim **15**, further comprising a linear actuator that is controllable to adjust the support member based on the characteristic of the user that is measured by the sensor.

* * * * *