



(19) **United States**

(12) **Patent Application Publication**
Jones et al.

(10) **Pub. No.: US 2023/0014610 A1**
(43) **Pub. Date: Jan. 19, 2023**

(54) **SYSTEMS WITH ADJUSTABLE WINDOWS**

Publication Classification

(71) Applicant: **Apple Inc.**, Cupertino, CA (US)
(72) Inventors: **Christopher D. Jones**, Los Gatos, CA (US); **Ibuki Kamei**, Santa Clara, CA (US); **James R. Wilson**, Saratoga, CA (US); **Clarisse Mazuir**, San Jose, CA (US); **John Raff**, Menlo Park, CA (US); **Budhadipta Dan**, San Jose, CA (US); **David E. Kingman**, San Francisco, CA (US); **Martin Melcher**, Paris (FR)

(51) **Int. Cl.**
B60J 3/04 (2006.01)
G02F 1/01 (2006.01)
B60J 3/00 (2006.01)
(52) **U.S. Cl.**
CPC *B60J 3/04* (2013.01); *G02F 1/0121* (2013.01); *B60J 3/007* (2013.01); *G02F 2203/02* (2013.01); *G02F 2203/01* (2013.01); *G02F 2203/03* (2013.01); *E06B 3/6722* (2013.01)

(21) Appl. No.: **17/949,109**

(22) Filed: **Sep. 20, 2022**

Related U.S. Application Data

(63) Continuation of application No. 16/815,898, filed on Mar. 11, 2020, now Pat. No. 11,498,397, which is a continuation of application No. 15/651,889, filed on Jul. 17, 2017, now Pat. No. 10,625,580.
(60) Provisional application No. 62/380,136, filed on Aug. 26, 2016.

(57) **ABSTRACT**

A system such as a vehicle may have adjustable structures such as adjustable windows. Adjustable windows may have adjustable layers such as adjustable tint layers, adjustable reflectivity layers, and adjustable haze layers. Adjustable window layers may be incorporated into a window with one or more transparent structural layers such as a pair of glass window layers. Adjustable components such as adjustable reflectivity layers, adjustable haze layers, and adjustable tint layers may be interposed between the pair of glass window layers. Fixed partially reflective mirrors, fixed tint layers, and/or fixed haze layers may be used in place of adjustable tint, haze, and reflectivity layers and/or may be incorporated into windows in addition to adjustable tint, haze, and reflectivity layers.

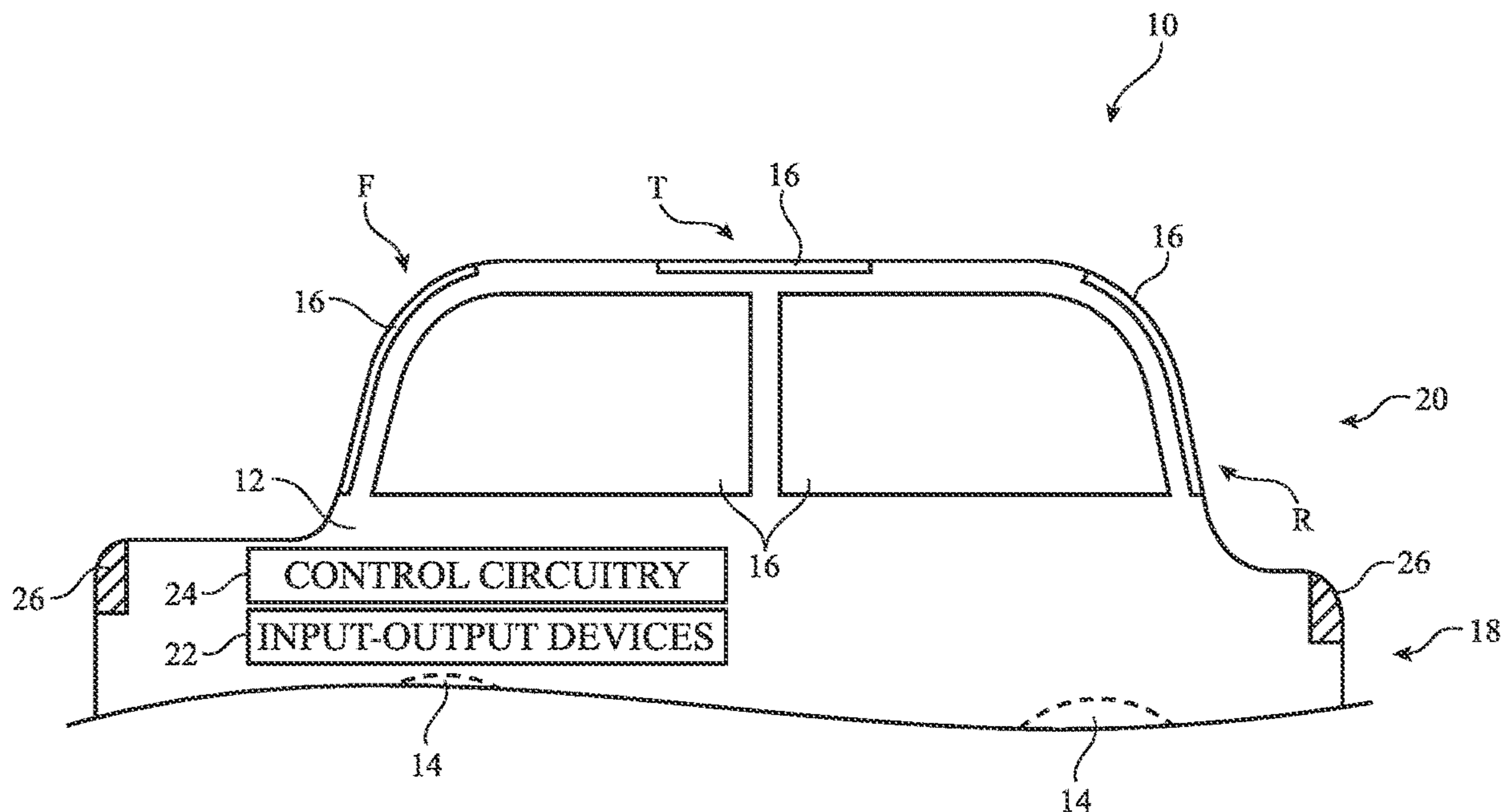

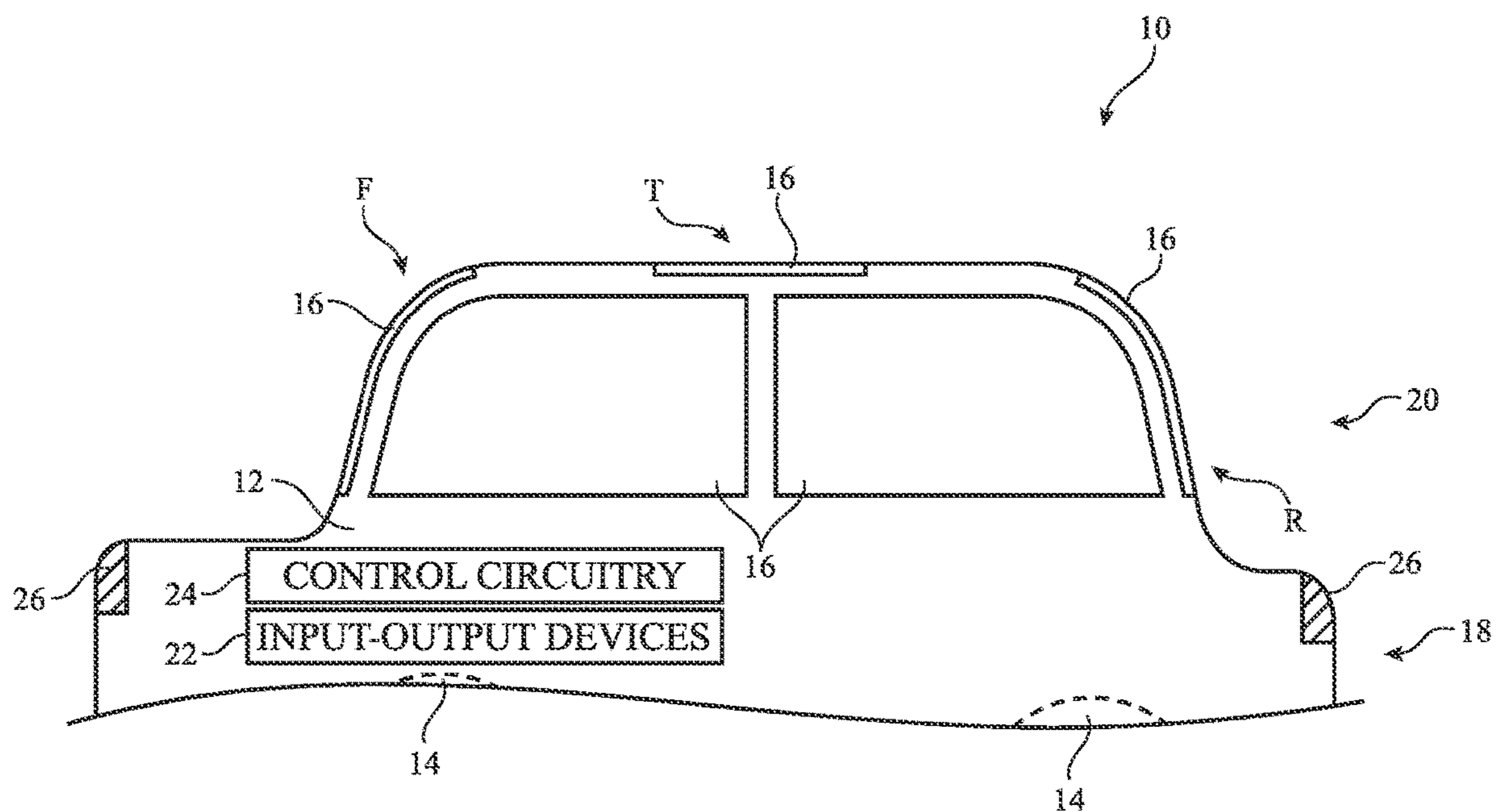

FIG. 1

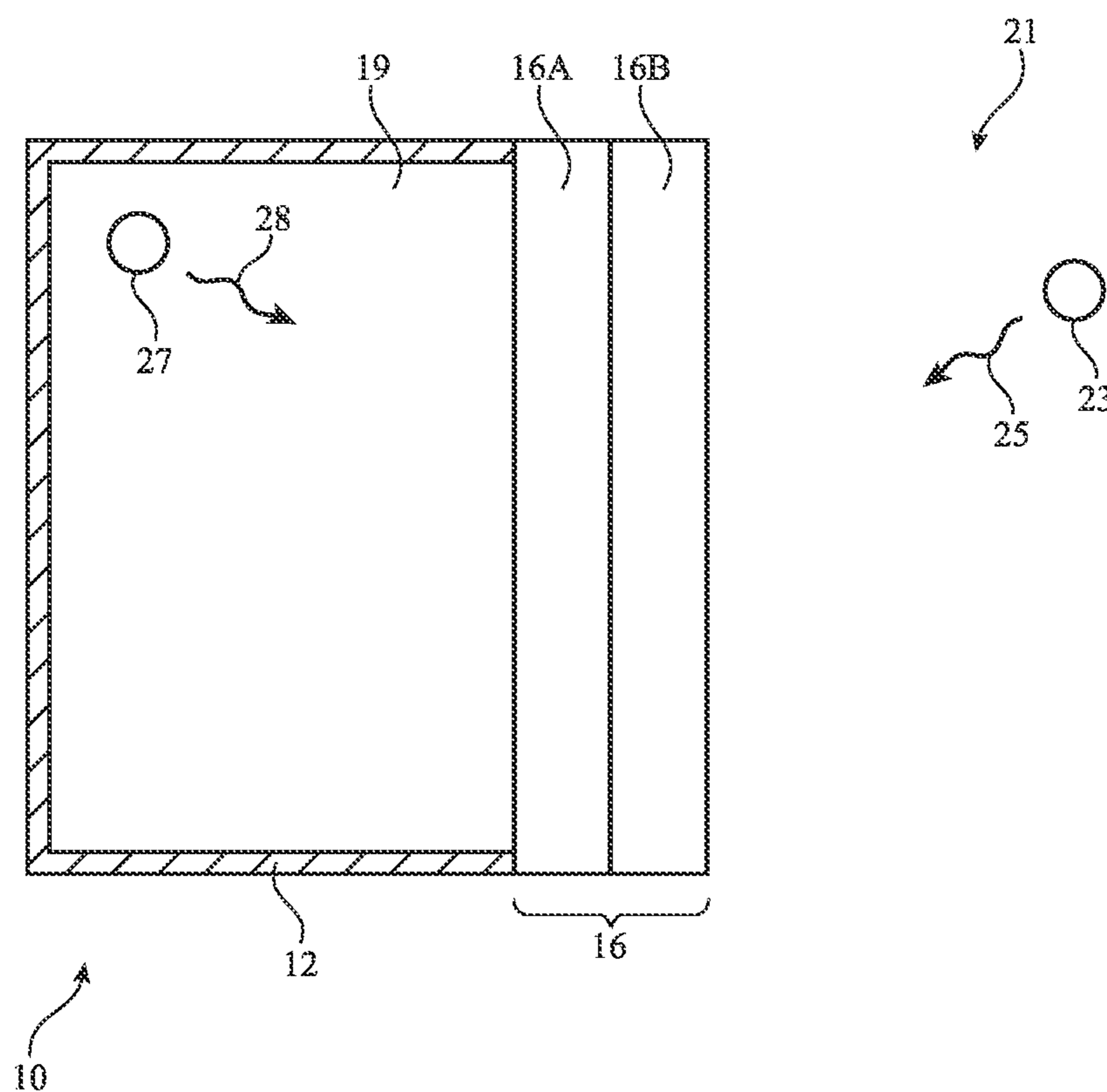

FIG. 2

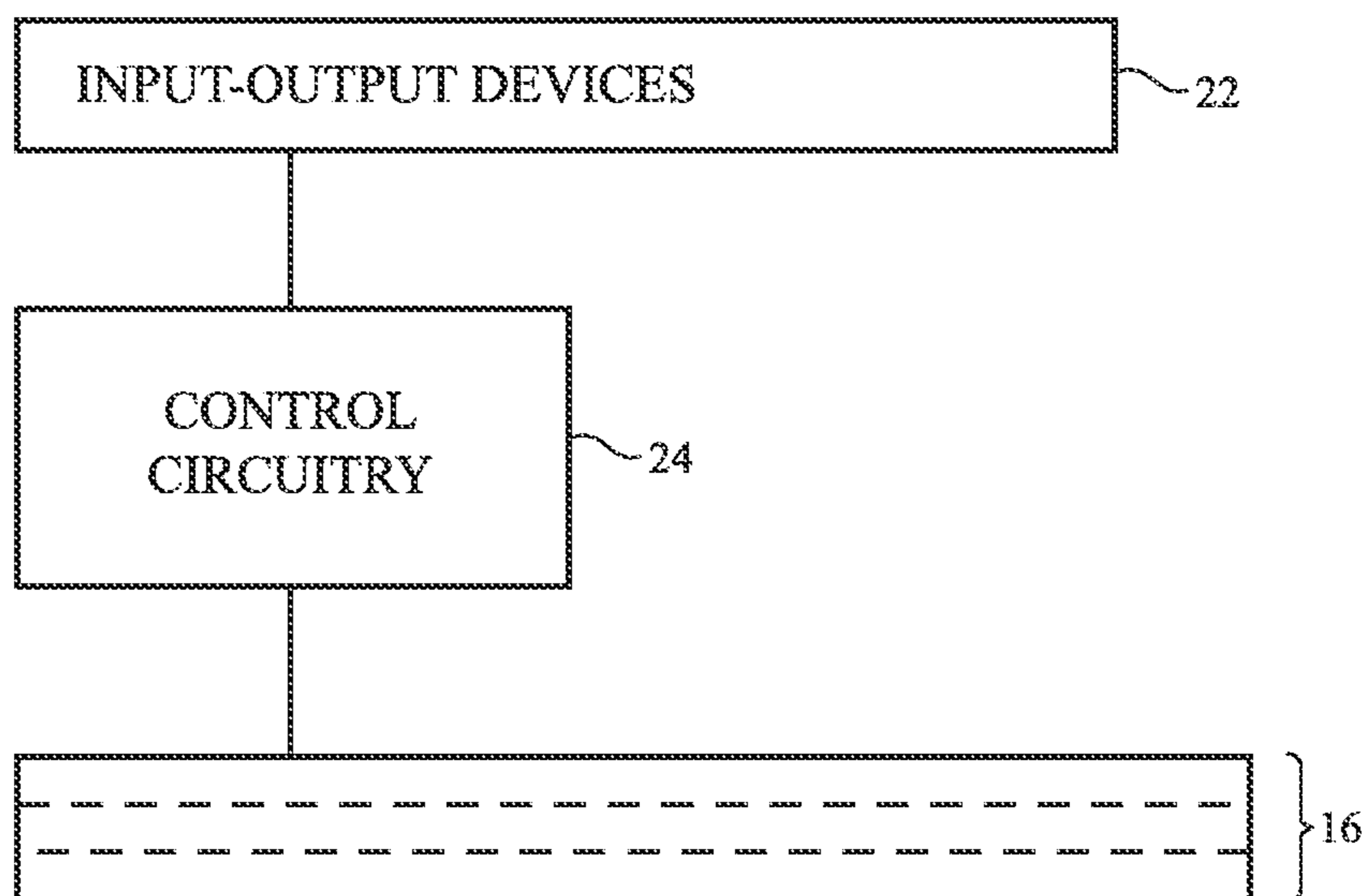

FIG. 3

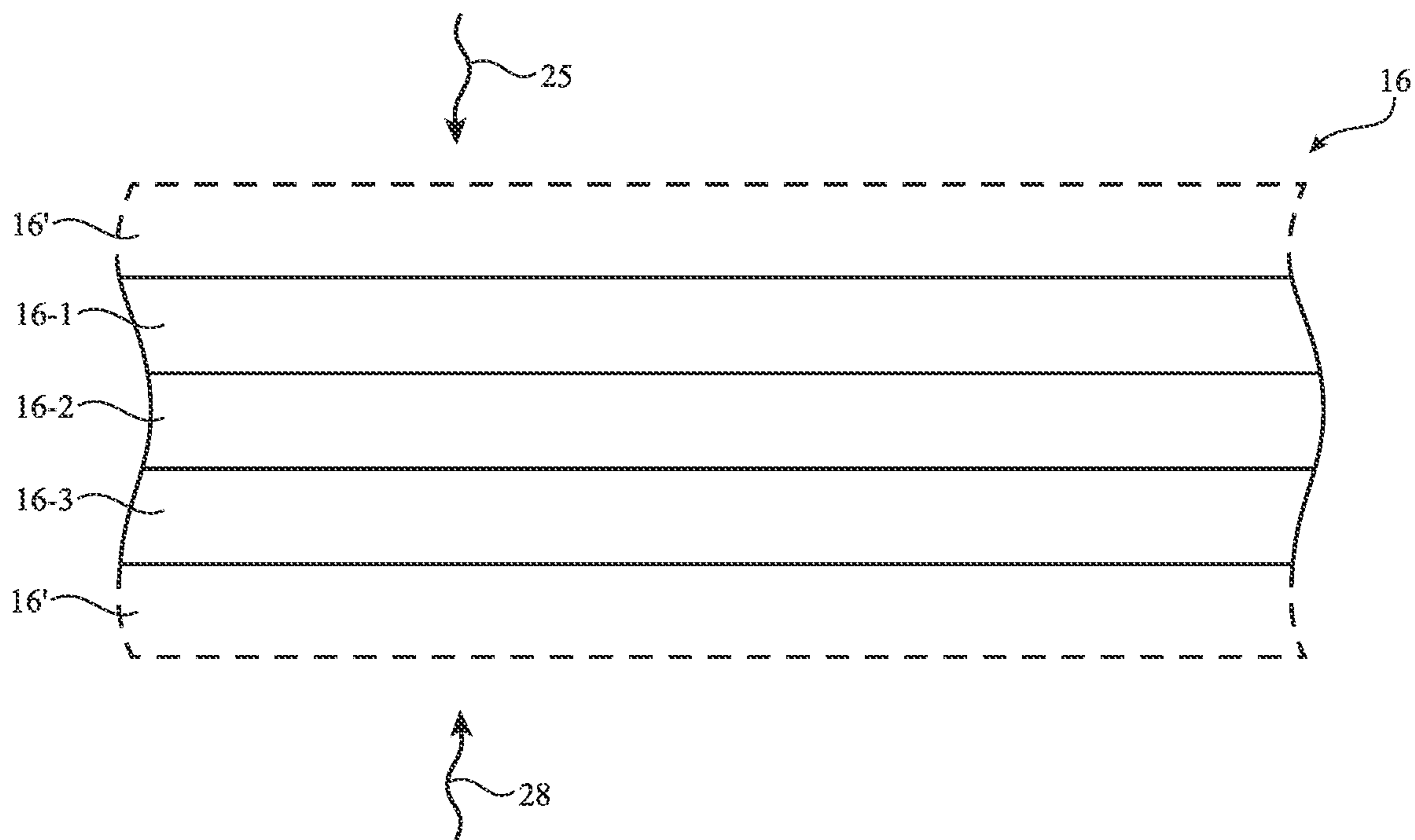

FIG. 4

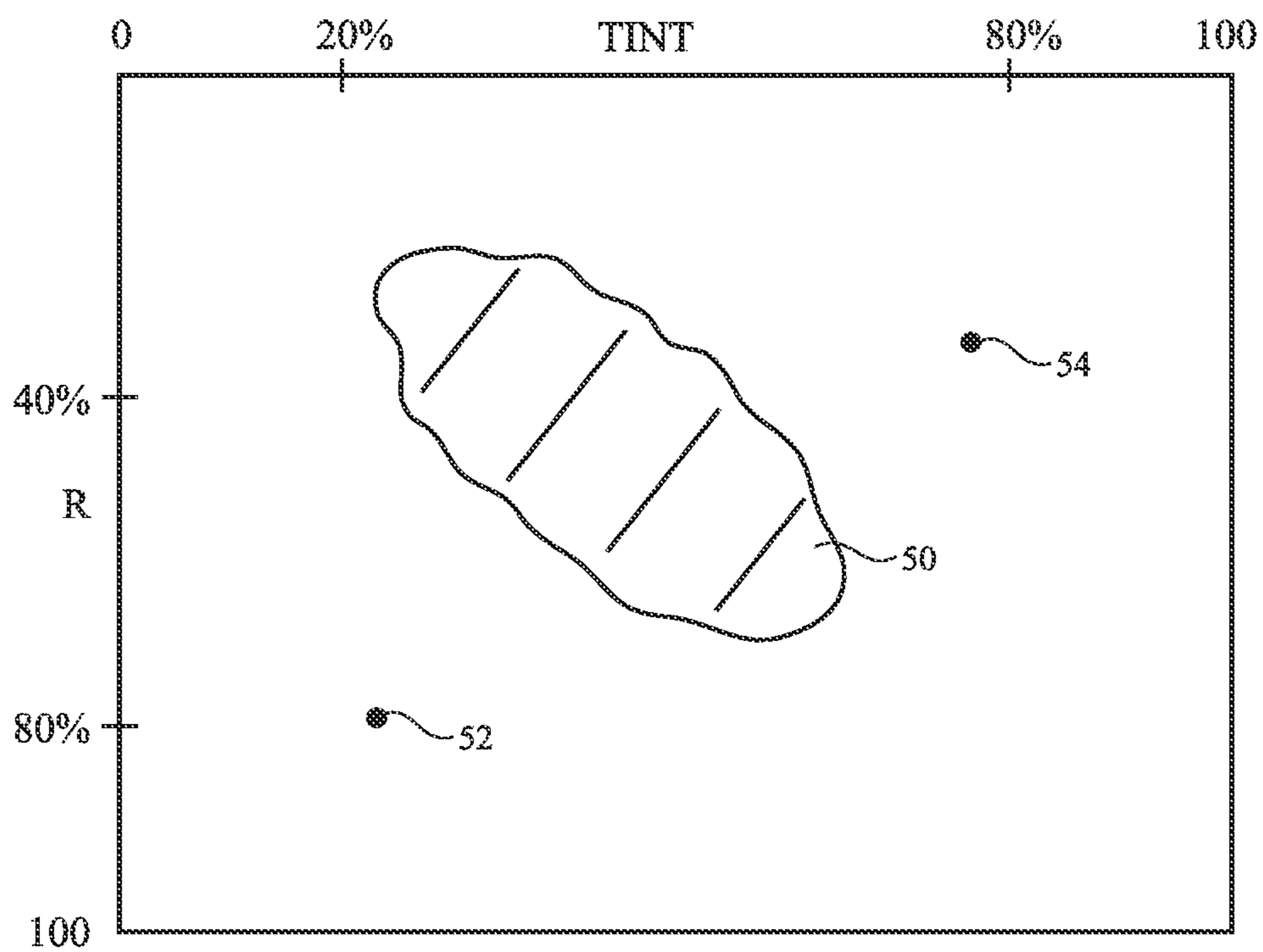

FIG. 5

		Day (light out, dark inside)					Night (dark out, light inside)				
Tint	Reflection	Haze	Effect/ Feature	Internal Appearance	See Out?	External Appearance	See In?	Internal Appearance	See Out?	External Appearance	See In?
ON	ON	OFF	1-way mirror	Dark	YES	Mirror	NO	Dark/ Reflect	NO	Shiny/Mirror	PART- IALLY
ON	OFF	OFF	Dark	Dark	YES	Dark	YES	Dark/ Reflect	NO	Dark	YES
OFF	ON	OFF	Shiny	Shiny	YES	Shiny	YES	Mirror	NO	Shiny	YES
OFF	OFF	OFF	Clear	Clear	YES	Clear	YES	Reflect	PART- IALLY	Clear	YES
ON	ON	ON	Privacy Mirror	Hazy	NO	Mirror	NO	Dark/ Reflect	NO	Shiny/Mirror	NO
ON	OFF	ON	Dark Privacy	Hazy	NO	Dark	NO	Dark/ Reflect	NO	Dark	NO
OFF	ON	ON	1/2 Privacy Mirror	Dark	NO	Mirror	NO	Dark/ Reflect	NO	Shiny	NO
OFF	OFF	ON	Bright Privacy	Light	NO	Light	NO	Dark/ Reflect	NO	Light	NO

66

64

62

60

FIG. 6

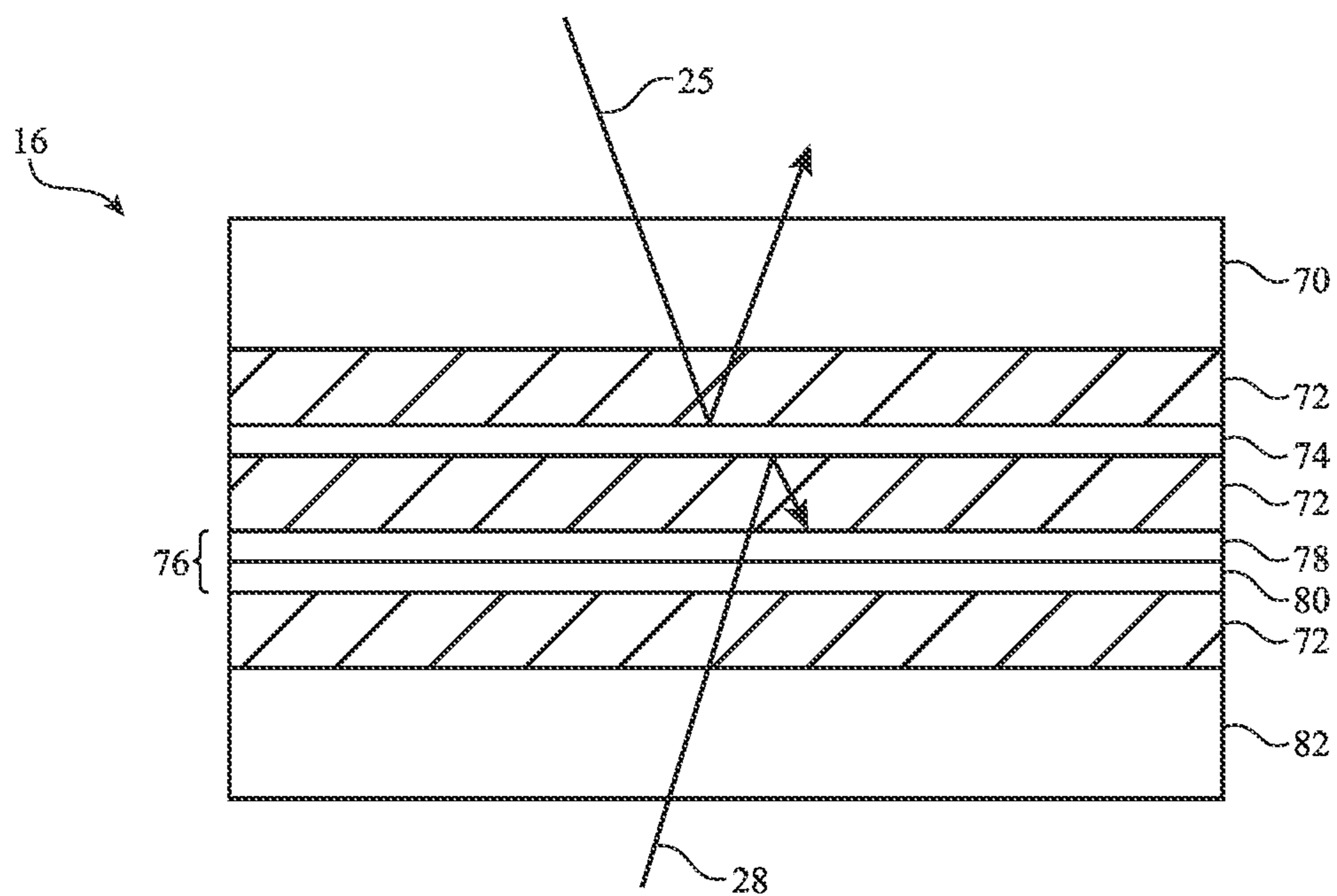

FIG. 7

SYSTEMS WITH ADJUSTABLE WINDOWS

[0001] This application is a continuation of U.S. patent application Ser. No. 16/815,898, filed on Mar. 11, 2020, which is a continuation of patent application Ser. No. 15/651,889, filed on Jul. 17, 2017, now U.S. Pat. No. 10,625,580, which claims the benefit of provisional patent application No. 62/380,136, filed on Aug. 26, 2016, each of which are hereby incorporated by reference herein in their entireties.

FIELD

[0002] This relates generally to structures that pass light, and, more particularly, to windows and other adjustable structures for systems such as vehicles and buildings.

BACKGROUND

[0003] It is desirable to provide vehicles and buildings with windows. Windows may be provided with frosted surfaces or mirror coatings to enhance privacy.

[0004] It can be challenging to incorporate light modifying structures such as frosted surfaces and mirror coatings into windows. If care is not taken, windows may be too reflective, may be insufficiently transparent for viewing, or may have other undesired attributes.

SUMMARY

[0005] A system such as a vehicle may have adjustable structures such as adjustable windows. Control circuitry in the vehicle may be used to adjust the adjustable windows based on user input and sensor input.

[0006] Adjustable windows may have adjustable layers such as adjustable tint layers, adjustable reflectivity layers, and adjustable haze layers. Adjustable window layers may be incorporated into a window with one or more transparent structural layers such as a pair of glass window layers. Adjustable components such as adjustable reflectivity layers, adjustable haze layers, and adjustable tint layers may be interposed between the pair of glass window layers. Fixed partially reflective mirrors, fixed tint layers, and/or fixed haze layers may be used in place of adjustable reflectivity, tint, and haze layers and/or may be incorporated into windows in addition to adjustable tint, haze, and reflectivity layers.

BRIEF DESCRIPTION OF THE DRAWINGS

[0007] FIG. 1 is a schematic diagram of an illustrative system in accordance with an embodiment.

[0008] FIG. 2 is a diagram showing how a window may have layers that modify light propagation in accordance with an embodiment.

[0009] FIG. 3 is a diagram of illustrative components in a system with a window in accordance with an embodiment.

[0010] FIG. 4 is a cross-sectional side view of an illustrative window having multiple layers in accordance with an embodiment.

[0011] FIG. 5 is graph showing how variations in the properties of window layers of the type shown in FIG. 4 may affect window performance in accordance with an embodiment.

[0012] FIG. 6 is a table showing how a window may be configured to operate in a variety of different modes in accordance with an embodiment.

[0013] FIG. 7 is a cross-sectional side view of an illustrative window having a reflective layer and a circular polarizer in accordance with an embodiment.

DETAILED DESCRIPTION

[0014] A vehicle or other system may have structures formed from one or more layers of glass, polymer, conductive material (e.g., transparent conductive material such as indium tin oxide), crystalline materials (e.g., sapphire), and/or other materials. The structures may include opaque layers and/or transparent layers (e.g., transparent glass and polymer layers, etc.).

[0015] The structures may include one or more adjustable layers such as adjustable tint layers, adjustable haze layers, and adjustable reflectivity layers. By suitable configuration of fixed and/or adjustable layers, windows in vehicles and other systems may be provided with desired attributes (e.g., a desired outward appearance such as a desired reflectivity, a desired light transmittance, a desired interior privacy level, etc.).

[0016] An illustrative system with windows is shown in FIG. 1. As shown in FIG. 1, system 10 may be a vehicle having portions such as portions 18 and 20. Portion 18 may include wheels 14, a body such as body 12 with a chassis to which wheels 14 are mounted, propulsion and steering systems, and other vehicle systems. Body 12 may include doors, trunk structures, a hood, side body panels, a roof, and/or other body structures. Seats may be formed in the interior of vehicle 10. Portion 20 may include window(s) 16. Window 16 and portions of body 12 may separate the interior of vehicle 10 from the exterior environment that is surrounding vehicle 10.

[0017] Windows 16 may include front windows on front F of vehicle 10, a moon roof window or other window extending over some or all of top T of vehicle 10, rear windows on rear R of vehicle 10, and side windows on the sides of vehicle 10 between front F and rear R. If desired, structures with adjustable tint, haze, and/or reflectivity may be used in forming laminated glass structures and other structures that serve as exterior lighting components (e.g., front and rear lights 26, center high mounted stop lamps, running lights, etc.).

[0018] Window 16 may be formed from one or more layers of transparent glass, clear polymer (e.g., polycarbonate), polymer adhesive layers, and/or other layers. In some arrangements, window(s) 16 may include laminated window structures such as one or more layers of glass with interposed polymer layer(s). The polymer in a laminated window may be, for example, a polymer such as polyvinyl butyral (PVB) or ethylene-vinyl acetate (EVA). Adjustable layers in window 16 may, if desired, be embedded in a polymer layer such as a PVB or EVA layer that is interposed between outer and inner glass layers.

[0019] Vehicle 10 may include control circuitry 24 and input-output devices 22. Control circuitry 24 may include storage and processing circuitry for supporting the operation of vehicle 10. The storage and processing circuitry may include storage such as hard disk drive storage, nonvolatile memory (e.g., electrically-programmable-read-only memory configured to form a solid state drive), volatile memory (e.g., static or dynamic random-access-memory), etc. Processing circuitry in control circuitry 24 may be used to control the operation of vehicle 10 and the components in vehicle 10 (e.g., components associated with windows 16,

lights 26, input-output devices 22, etc.). For example, processing circuitry can adjust the haze, tint (light transmission), and/or reflectivity of one or more layers in windows 16 and may make adjustments to other input-output devices 22, and/or may make other adjustments to components such as windows 16, lights 26, etc. The processing circuitry may be based on one or more microprocessors, microcontrollers, digital signal processors, baseband processors, power management units, audio chips, application specific integrated circuits, etc.

[0020] Input-output devices 22 may allow data to be supplied to vehicle 10 and to a user and may allow data to be provided from vehicle 10 to external systems or a user. Input-output devices 22 may include buttons, scrolling wheels, touch pads, key pads, keyboards, and other user input devices. Microphones may be used to gather voice input from a user and may gather information on ambient sounds. Devices 22 may include ambient light sensors, proximity sensors, magnetic sensors, force sensors, accelerometers, image sensors, and/or other sensors for gathering input. Output may be supplied by devices 22 using audio speakers, tone generators, vibrators, haptic devices, displays, light-emitting diodes and other light sources, and other output components. Devices 22 may include wired and wireless communications circuitry that allows vehicle 10 (e.g., control circuitry 24) to communicate with external equipment and that allows signals to be conveyed between components (circuitry) at different locations in vehicle 10. Light modulators, adjustable reflectivity structures, and/or adjustable haze structures for windows 16 may be included in devices 22.

[0021] During operation, input from devices 22 (e.g., user input, ambient light sensor measurements such as measurements on exterior light levels, interior light level measurements or other interior light level information, and/or other input from devices 22) may be used by control circuitry 24 in making adjustments to interior lighting and to the light transmission, reflectivity, and/or haze of windows 16. For example, control circuitry 24 can adjust windows 16 to enhance privacy, to change the appearance of windows 16 from the interior and/or exterior of vehicle 10, and/or to change the amount of light transmission through windows 16. Control circuitry 24 may make these adjustments automatically based on sensor input, based on user commands, and/or based on other information.

[0022] In some configurations, one or more layers of windows 16 may be used to create a one-way mirror effect for vehicle 10. Consider, as an example, a scenario of the type shown in FIG. 2. In the example of FIG. 2, window 16 includes at least first (inner) window layer 16A and second (outer) window layer 16B. Window 16 may be mounted in body 12 of vehicle 10. Vehicle 10 may have an interior region such as interior 19 and an exterior region such as region 21. Window 16 may separate interior 19 from exterior 21. Layers such as layers 16A and 16B may have optical properties (e.g., transmission and/or reflectivity) that can be adjusted to adjust the behavior of window 16 in a variety of lighting conditions.

[0023] Layers 16A and 16B may be, for example, layers with fixed and/or adjustable levels of tint (i.e., light absorption and therefore light transmission) and reflectivity. With one illustrative arrangement, layer 16A is an adjustable tint layer (sometimes referred to as a light modulator or adjustable absorption layer) and layer 16B is an adjustable reflectivity layer.

Configurations in which one or both of these layers are not adjustable and/or in which additional layers with fixed and/or adjustable properties (e.g., adjustable haze, etc.) may also be used. The arrangement in which layer 16A is an adjustable tint layer and in which layer 16B is an adjustable reflective layer is merely illustrative.

[0024] Using an adjustable tint layer (layer 16A) and adjustable reflectivity layer (layer 16B), users of vehicle 10 may make adjustments that increase or decrease privacy. For example, vehicle occupants in vehicle 10 may increase the reflectivity of layer 16B when it is desired to reflect more exterior light back towards observers outside of vehicle 10. When layer 16B exhibits low reflectivity, privacy is minimized and external observers may be able to view vehicle occupants through window 16. When layer 16B exhibits high reflectivity, privacy is maximized. In this situation, layer 16B reflects external light towards observers outside of vehicle 10, window 16 exhibits a one-way mirror behavior, and external observers cannot easily view the interior of vehicle 10.

[0025] In addition to adjusting privacy by making automatic or user-specified adjustments to the reflectivity of layer 16B, it may be desirable to adjust the light transmission properties of window 16 by adjusting the amount of light absorption exhibited by adjustable tint layer 16A. If a vehicle occupant wishes to view the surroundings of vehicle 10 clearly, tint may be minimized to maximize light transmission through window 16. If a vehicle occupant wishes to reduce the amount of exterior lighting that enters vehicle 10 (e.g., to cut down on bright light during the day), the tint level of layer 16A may be increased.

[0026] Tint level adjustments can affect privacy in windows that include a reflective layer such as adjustable reflectivity layer 16B.

[0027] Consider, as an example, a scenario in which layer 16B exhibits a 50% light reflectivity and in which layer 16A is adjusted to operate in three different light absorption modes: a low absorption mode in which layer 16A exhibits a low absorption such as 0% absorption, a moderate absorption mode in which layer 16A exhibits a moderate absorption such as a 50% absorption, and a high absorption mode in which layer 16A exhibits a high absorption such as a 80% absorption. In this illustrative scenario, the internal light level (i.e., the amount of light 28 generated by internal lighting source 27 in interior 19 of vehicle 10) may have a value of 20 (in arbitrary light intensity units), whereas the external light level (i.e., the amount of light 25 generated by external light source 23 in exterior region 21) may have a value of 100 (in the same arbitrary light intensity units). In the low absorption mode, an external observer will observe 50 light intensity units due to reflection of the outside lighting from reflective layer 16B and will observe 10 light intensity units due to interior light that has transmitted through window 16 (i.e., the 20 interior light intensity units will be reduced by a factor of two due to the 50% light transmission of layer 16B). The low absorption mode will therefore be characterized by a ratio of 5:1 for the amount of external light that is reflected from window 16 relative to the amount of internal light that passes through window 16. In the moderate and high absorption modes, this ratio is respectively 10:1 and 25:1 due to the absorption of layer 16A. Higher ratios of reflected external light to transmitted interior light are associated with a greater one-way mirror effect and therefore enhanced privacy.

[0028] The same type of behavior (privacy enhancement with increasing tint level) holds in lighting scenarios in which interior light levels are closer to exterior light levels. For example, consider another possible scenario in which exterior light is characterized by a value of 100 light intensity units and in which interior light is characterized by a value of 100 light intensity units. In an illustrative configuration in which adjustable reflectivity layer **16B** is set to exhibit 50% reflectivity, tint layer **16A** may again be adjusted between the low, moderate, and high light absorption modes. Window **16** may then exhibit a 1:1 outside reflected light to interior transmitted light ratio for the low absorption mode, a 2:1 ratio for the moderate absorption mode, and a 5:1 ratio for the high absorption mode. Although there is less privacy in this lighting scenario, the addition of tint still enhances privacy by increasing the ratio of reflected exterior light to transmitted interior light.

[0029] In yet another lighting scenario, exterior light may be characterized by a value of 50 light intensity units and interior light may be characterized by a value of 100 light intensity units. Adjustable reflectivity layer **16B** may be set to exhibit 50% reflectivity. Tint layer **16A** may be adjusted between the low, moderate, and high light absorption modes. Window **16** may then exhibit a 1:2 outside reflected light to interior transmitted light ratio for the low absorption mode, a 1:1 ratio for the moderate absorption mode, and a 2.5:1 ratio for the high absorption mode. Because the outside light level is lower than the interior light level in this scenario, it may be desirable to use the highest tint level to ensure privacy.

[0030] As these examples demonstrate, adjustments to the tint level of layer **16A** affect not only light transmission level (i.e., how dark window **16** appears to a vehicle occupant), but how much privacy is provided. By independently adjusting tint and reflection, the outward appearance of window **16** can be adjusted (from more shiny when layer **16B** is more reflective to less shiny when layer **16A** is less reflective), privacy can be adjusted (from more private when layer **16B** is more reflective and/or tint layer **16A** is more absorbing and less transmissive), and window transmission can be adjusted (from lower when tint and/or reflectivity levels are high to higher when tint and/or reflectivity levels are lower).

[0031] If desired, window **16** may have one or more additional layers such as an adjustable haze layer to provide further adjustability to the optical properties of window **16**. These properties may be adjusted based on user input and/or input from sensors or other input-output devices **22**. As shown in FIG. 3, control circuitry **24** may be coupled to input-output devices **22** and window **16**. Window **16** may include one or more layers that have been laminated together or otherwise stacked together. These layers may affect tinting, reflectivity, haze, and/or other optical characteristics and may be adjusted by control circuitry **24** based on user input received using user input devices in input-output devices **22** (e.g., a keyboard, a touch screen, a microphone gathering voice input, buttons, a wireless link from a coupled portable electronic device or other wireless device, etc.) and/or based on measured interior and/or exterior lighting levels (e.g., an exterior light level measured by an ambient light sensor in devices **22**, an interior light level determined based on known interior lighting level settings and/or measured interior light levels) or based on other data gathered using input-output devices **22**. Adjustments that are made by control circuitry **24** to the adjustable components of window **16** may be made periodically (e.g., once per min-

ute), may be made in response to receiving user input, may be made in response to changes in the operating environment of vehicle **10** (e.g., changes in ambient lighting conditions), or may be made when other suitable criteria are satisfied.

[0032] A cross-sectional side view of window **16** in an illustrative configuration in which window **16** has at least three adjustable layers is shown in FIG. 4. As shown in FIG. 4, window **16** may have outer and inner layers such as optional layers **16'**. Layers **16'** may be formed from glass, rigid plastic (e.g., polycarbonate, etc.) and/or other materials. Layers **16'** may be clear and/or may be tinted. Layers **16'** may be laminated together using one or more interposed layers of adhesive (e.g., PVB, EVA, etc.).

[0033] One or more adjustable layers such as layers **16-1**, **16-2**, and **16-3** may be interposed between outer and inner layers **16'** (e.g., layers such as layers **16-1**, **16-2**, and **16-3** may be laminated between glass layers or other layers **16'** using PVB, EVA, and/or other adhesive). One or more structural layers such as layers **16'** may be omitted in configurations for window **16** in which structural support is provided by other layers (e.g., when layers **16-1**, **16-2**, and/or **16-3** include glass and/or plastic layers that provide window **16** with structural support). Layers **16-1**, **16-2**, and/or **16-3** may include adjustable components such as an adjustable tint layer, an adjustable reflectivity layer, and/or an adjustable haze layer. In some configurations, the functions of two or more of these layers may be combined into a single component. For example, a component may exhibit both adjustable haze and adjustable tint.

[0034] If desired, layers such as layers **16-1**, **16-2**, and **16-3** may be formed as coatings. For example, one or more of these layers may be formed as a coating on an inner surface of an exterior layer **16'** or as a coating on an outwardly facing surface of an inner layer **16'**. As another example, one or more of layers **16-1**, **16-2**, and **16-3** may be formed as a coating on another of layers **16-1**, **16-2**, and **16-3**. For example, layer **16-2** may be an adjustable haze layer and layer **16-1** may be a thin-film metal coating on layer **16-2** (e.g., a coating on a glass or plastic substrate in layer **16-2**) that serves as a partially reflective mirror coating for window **16**. Additional structural and/or functional layers (e.g., antireflection coating layers, fixed reflectivity partial mirror coatings, fixed tint coatings, and/or fixed haze layers, antiscratch layers, etc.) may be incorporated into window **16** if desired. The configuration of FIG. 4 is merely illustrative.

[0035] In a configuration with multiple adjustable layers such as layers **16-1**, **16-2**, and **16-3**, layer **16-1** may, as an example, be an outwardly facing layer that receives exterior light **25**. Exterior light **25** that has passed through layer **16-1** may then pass through the other layers of window **16** (e.g., layers **16-2** and **16-3**). Layer **16-3** may be an inwardly facing layer that receives interior light **28**. Interior light **28** that has passed through layer **16-3** may then pass through layers **16-2** and **16-1**.

[0036] With one illustrative configuration, layer **16-1** is an adjustable reflectively layer, layer **16-2** is an adjustable haze layer, and layer **16-3** is an adjustable tint layer (i.e., a light modulator). If desired, the positions of any two of these layers may be swapped. As an example, layer **16-2** may be an adjustable tint layer and layer **16-3** may be an adjustable haze layer. Structural layers and/or other adjustable component layers may be interposed between these layers, if

desired. Arrangements in which layer **16-3** provides adjustable tint, layer **16-2** provides adjustable haze, and layer **16-1** provides adjustable reflectivity may sometimes be described herein as an example.

[0037] Any suitable adjustable components may be used in forming layers **16-1**, **16-2**, and **16-3**. As one example, adjustable reflectivity layer **16-3** may be an adjustable reflectivity component such as a cholesteric liquid crystal layer. A cholesteric liquid crystal device may exhibit a mirror reflectivity that is adjustable. When used in layer **16-3**, the cholesteric liquid crystal device may be characterized by an “on” state and an “off” state. In the “on” state (e.g., when control circuitry **24** applies a voltage to layer **16-3**), the cholesteric liquid crystal device may be transparent. The transmission of the cholesteric liquid crystal device may be adjusted by adjusting the applied voltage (i.e., layer **16-3** may serve both as an adjustable reflectivity layer and as an adjustable tint layer). In the “off” state, the cholesteric liquid crystal device may act as a partial mirror and may reflect more than 50% of incident light, more than 70% of incident light, less than 99% of incident light, or other suitable amount of incident light.

[0038] Cholesteric liquid crystal layers may exhibit relatively fast switching speeds, low haze (e.g., haze values of less than 5%), and good reflectivity (e.g., when “off”). If desired, adjustable reflectivity layers such as layer **16-1** may be implemented using other types of adjustable mirror components. For example, an adjustable reflectivity component for layer **16-1** may be formed from a solid-state switching mirror component based on a switchable metal hydride film (e.g., layer **16-1** may be an adjustable magnesium hydride mirror).

[0039] If desired, an adjustable reflectivity layer such as a cholesteric liquid crystal layer or switchable metal hydride film may be embedded within a PVB layer or other adhesive layer that is sandwiched between a pair of laminated glass layers (e.g., glass window layers that are being joined by the PVB layer to form a laminated window).

[0040] Adjustable tint layer **16-3** may be formed from a light modulator component such as an electrochromic device, guest-host liquid crystal device, or a suspended particle device (as examples). Other types of adjustable components may be used in implementing adjustable tint layer **16-3**, if desired.

[0041] An electrochromic device may have a pair of transparent electrodes. An electrolyte such as LiNiOP (e.g., a gel electrolyte) may be interposed between electrochromic coatings on the electrodes. The electrochromic coatings may be, for example, a Li_xNiO coating on a first of the electrodes and a WO_3 coating on a second of the electrodes. The electrodes may be used to apply a current to the electrochromic coatings to either darken (color) or lighten (discolor) layer **16-3**. Electrochromic devices may exhibit low haze (e.g., less than 5%) and may maintain their current state in the event of a failure. If desired, layer **16-3** may be implemented using a solid state electrochromic device in which solid organic or inorganic material is used to form the electrochromic electrolyte.

[0042] A guest-host liquid crystal device may include a light-absorbing dye “guest” in a liquid crystal “host” layer. These materials may form a layer that is sandwiched between a pair of transparent electrodes. When an electric field is applied to the guest-host layer, the liquid crystals rotate, thereby rotating the guest dye into an orientation that

enhances light absorption. When the electric field is removed, the guest dye molecules are no longer held in the high-absorption orientation so that layer **16-3** becomes transparent.

[0043] Layer **16-3** may also be implemented using a suspended particle device. A suspended particle device contains a layer of nanoparticles suspended in a liquid that is sandwiched between substrate layers with transparent conductive electrodes. In the absence of an applied electric field, the nanoparticles are randomly oriented and absorb light (i.e., the tint of layer **16-3** is dark). When an electric field is applied, the nanoparticles align and allow light to pass (i.e., the tint of layer **16-3** is clear). In addition to allowing an adjustable tint to be obtained, suspended particle devices are characterized by an associated adjustable haze (e.g., a 6% haze when the suspended particle device is off and is exhibiting a low amount of light absorption and a 50% haze when the suspended particle device is on and is exhibiting a high amount of light absorption). In this way, a suspended particle device may serve both as an adjustable tint layer (layer **16-3**) and as an adjustable haze layer (layer **16-2**).

[0044] If desired, haze may be adjusted independently using an adjustable haze layer such as layer **16-2**. Layer **16-2** may be implemented using a polymer-dispersed liquid crystal device. In this type of device, a polymer layer having voids filled with liquid crystal material may be sandwiched between conductive transparent electrodes on respective first and second transparent substrates. When no electric field is applied to the electrodes, the liquid crystals in the voids are randomly oriented and exhibit an index-of-refraction difference with the surrounding polymer layer. This causes the liquid crystal material of the voids to produce a relatively large amount of haze that scatters light that is passing through layer **16-2**. When electric field is applied to the electrodes by control circuitry **24**, the liquid crystals of the liquid crystal material in the voids becomes aligned so that the liquid crystal material in the voids exhibits an index of refraction that matches the surrounding polymer. In this configuration, layer **16-2** exhibits low haze and high transparency. Intermediate haze levels may be achieved by applying an electric field at an intermediate level.

[0045] If desired, one or more of layers **16-1**, **16-2**, and **16-3** (and, if desired, layers such as glass layers **16'** of FIG. **4**) may be implemented using fixed reflectivity layers (e.g., thin reflective metal coatings, thin reflective dielectric stack coatings, etc.), fixed tint (e.g., glass or polymer that has been darkened by incorporation of light-absorbing particles, dye, metal coating material, etc.), and/or fixed haze (e.g., by incorporating a textured polymer or glass layer, a hazy layer formed from microbubbles or light-scattering particles in a glass or plastic material, etc.). The use of adjustable layers in providing window **16** with adjustable tint, haze, and reflectivity is merely illustrative.

[0046] The use of independently adjustable tint and reflectivity to provide window **16** with different configurations is shown in FIG. **5**. In the example of FIG. **5**, the amount of light absorption (TINT) of an adjustable tint layer in window **16** has been plotted on the horizontal axis and the amount of light reflection (R) for an adjustable reflectivity layer has been plotted vertically for an illustrative window having an adjustable tint layer and an adjustable reflectivity layer. In regions of the graph of FIG. **5** such as region **50**, the adjustable tint layer and the adjustable reflectivity layer have been provided with intermediate values and window **16** may

exhibit a one-way mirror behavior. When, as illustrated by point **52** on the graph of FIG. **5**, the tint and reflectivity layers have been adjusted to exhibit a relatively high reflectivity (e.g., $R=80\%$) and a relatively low tint (e.g., $TINT=20\%$), window **16** may exhibit a relatively high amount of privacy. For example, the ratio of reflected external light to internal light that is transmitted through window **16** (sometimes referred to as the “privacy factor” of window **16**) may be about 10 in an illustrative operating scenario in which outside light has an intensity of 100 light intensity units and in which interior light has an intensity of 50 light intensity units. When, as illustrated by point **54** on the graph of FIG. **5**, the tint and reflectivity layers have been adjusted to exhibit a moderate reflectivity (e.g., $R=40\%$) and a relatively high tint (e.g., $TINT=85\%$) under the same lighting conditions, window **16** may continue to exhibit the same ratio of reflected external light to transmitted internal light (i.e., the privacy factor may still be 10 in this example).

[0047] Window **16** may therefore exhibit the same amount of privacy whether configured to operate with the settings of point **52** or the settings of point **54**. When operated with the settings of point **52**, however, window **16** may be very shiny when viewed from the exterior of vehicle **10**, whereas window **16** may exhibit relatively low reflectivity when operated with the settings of point **54**. Moreover, the total transmission of window **16** (i.e., the amount of exterior light that an internal viewer can observe through window **16**) will be 15% when operated with the settings of point **52** and only 8% when operated with the settings of point **54**. As this example demonstrates, window **16** may be configured to adjust its outward appearance and/or to adjust the light transmission of window **16** to accommodate user preferences for appearance and/or light transmission while continuing to maintain a desired privacy level. Other types of adjustments may also be made (e.g., to adjust privacy while maintaining a desired light transmission setting, etc.).

[0048] In configurations for window **16** that include adjustable haze, additional adjustments to window **16** may be made. Haze provides windows **16** with a milky appearance and enhances privacy. Regardless of the relative values of interior and exterior light levels, increased haze will provide enhanced privacy by preventing exterior observers from viewing interior vehicle occupants through window **16**.

[0049] FIG. **6** is a table in which illustrative window settings and associated optical properties have been listed for a window with adjustable tint, haze, and reflectivity. Illustrative combinations of high tint (“on”), low tint (“off”), high reflectivity (“on”), low reflectivity (“off”), high haze (“on”), and low haze (“off”) with which window **16** may be provided using adjustable components such as adjustable tint layer **16-3**, adjustable haze layer **16-2**, and adjustable reflectivity layer **16-1** are shown in columns **60**. If desired, some of these attributes may be provided using components that provide fixed tint, haze, and/or reflectivity and/or using fewer components or more components to produce adjustable amounts of tint, haze, and/or reflectivity. Each row of the table of FIG. **6** has a different associated combination of tint, reflectivity (reflection), and haze. Each row of column **62** lists a different overall effect that is produced by the combination of settings associated with that row. Columns **64** and columns **66** detail the internal appearance, external appearance, and ability to see in and out of vehicle **10** through window **10** that are associated with each combination of settings. Columns **64** are associated with the opera-

tion of window **16** when the ambient environment of vehicle **10** is bright and the interior of vehicle **10** is dark. Columns **66** are associated with the operation of window **16** when the ambient environment of vehicle **10** is dark and the interior of vehicle **10** is light.

[0050] If desired, other combinations of adjustable layers may be provided in window **16**, any of the adjustable layers may be replaced by a fixed layer (e.g. a fixed tint, haze, and/or reflectivity) to reduce window complexity, and/or other fixed and/or adjustable layers may be incorporated in window **16**. Adjustments to the components of window **16** may, as illustrated in FIG. **6**, be used to increase or decrease privacy, may be used to alter the outward appearance of window **16** (e.g., to make window **16** more or less reflectivity), may be used to alter light transmission (e.g., so that the occupants of vehicle **10** can view out of window **16** with minimal light intensity reduction or with a strong light intensity reduction, etc.).

[0051] In addition to or instead of using adjustable components such as adjustable layers **16-1**, **16-2**, and **16-3** in windows **16**, some or all of these layers may be used in adjusting the performance and appearance of other devices in vehicle **10** such as exterior lights **26**, a dashboard or other device that includes a display (e.g., a display that is laminated with layers **16-1**, **16-2**, and/or **16-3**), components in a building or other system other than a vehicle, etc. Windows **16** and other components in a system such as vehicle **10** may be adjusted in real time based on user input, based on sensor readings, and/or based on other suitable criteria. During operation, control circuitry **24** can adjust each window **16** in vehicle **10** separately. For example, control circuitry **24** may adjust the tint or other window settings of a vehicle differently for the windows on different sides of vehicle **10** in response to user commands or sensor input. If desired, ultraviolet-light-blocking filter layers, infrared-light-blocking filter layers, and/or other filter layers may be incorporated into windows **16**.

[0052] If desired, windows **16** may include polarizers. Consider, as an example, window **16** of FIG. **7**. Window **16** may have structural window layers such as outer structural layer **70** and inner structural layer **82**. Layers **70** and **82** may be formed from clear plastic, transparent glass, or other structural window materials. In the example of FIG. **7**, window **16** has an outer layer **70** such as outer glass layer and an inner layer **82** such as an inner glass layer. More structural window layers or fewer structural window layers may be included in window **16** if desired.

[0053] The layers of window **16** may include layers that are separated by air gaps and/or may include layers that are laminated together using interposed layers of adhesive. For example, a polymer adhesive layer such as layer **72** may be used in coupling layers **70** and **82** together. One or more additional layers such as layers **74** and **76** (e.g., fixed and/or adjustable reflectivity layers, fixed and/or adjustable haze layers, fixed and/or adjustable tint layers, polarizers, etc.) may be embedded within layer **72**. Layer **72** may be, for example, a polymer layer such as a layer of polyvinyl butyral (PVB) or ethylene-vinyl acetate (EVA).

[0054] In the illustrative configuration of FIG. **7**, layer **74** is a fixed or adjustable reflectivity layer and layer **76** is a polarizer layer. Window polarizer layers such as layer **76** may be linear polarizers or circular polarizers (as examples). Circular polarizers (e.g., circular polarizers with vertically polarized linear polarizer layers) and vertically polarized

linear polarizers may enhance the ability of sunglass-wearing occupants to view exterior objects through window 16. In the FIG. 7 example, layer 76 is a circular polarizer layer having linear polarizer layer 80 and quarter wave plate 78. Polarizer 76 and layer 74 may be embedded within layer 72 and/or polarizer 76 may be formed as a coating on layer 72. Configurations in which layers such as layers 74 and/or 76 are formed as coatings on layers 70 and/or 82 may also be used.

[0055] When the exterior of vehicle 10 is relatively bright, reflective layer 74 may enhance privacy for vehicle 10 by reflecting most of exterior light 25, as shown in FIG. 7 (e.g., reflective layer 74 may act as a one-way mirror). The presence of reflective material in reflective layer 74 may create undesirable internal reflections (i.e., reflections of internal light 28 back into the interior of vehicle 10). To suppress these reflections, circular polarizer 76 may be formed on the inwardly facing side of reflective layer 74. As shown in FIG. 7, for example, circular polarizer 76 may be interposed between inner glass layer 82 and reflective layer 74. When interior light 28 passes through circular polarizer 76, it become circularly polarized (e.g., with right-hand circular polarization). When the right-hand circularly polarized light (in this example) reflects back towards the interior of vehicle 10 from reflective layer 74, it becomes left-hand circularly polarized and will be prevented from returning to the interior of vehicle 10 by polarizer 76 (e.g., polarizer 76 serves to block interior light reflections from reflective layer 72 and thereby enhances the interior appearance of window 16 to vehicle occupants).

[0056] If desired, privacy may be enhanced by illuminating the interior of vehicle 10 with polarized light and incorporating a blocking polarizer in windows 16. As an example, interior light source 27 of FIG. 2 (e.g., a light-emitting diode light source, a lamp, a display, or other interior lighting) may be configured to emit horizontally polarized light (e.g., light 28 that is polarized along the Y axis (or other direction in the XY plane) of FIG. 2. Window 16 may incorporate a linear polarizer (e.g., linear polarizer layer 80 of FIG. 7) that has a pass axis that is oriented along the Z axis. With this configuration, the polarization direction of light 28 is perpendicular to the polarization direction of the linear polarizer, so light 28 will be blocked and thereby prevented from exiting window 16. Because interior lighting is prevented from exiting vehicle 10, privacy is enhanced. If desired, light source 27 may produce circularly polarized light (e.g., right-hand circularly polarized light) and the blocking polarizer in window 16 may be a blocking circular polarizer (e.g., a circular polarizer that blocks right-hand circularly polarized light).

[0057] Linear polarizers and/or circular polarizers may be incorporated into window 16 in arrangements having a fixed reflector and/or an adjustable reflector, having a fixed haze layer and/or an adjustable haze layer, having a fixed tint layer and/or an adjustable tint layer, and/or having any other suitable window layers.

[0058] The foregoing is merely illustrative and various modifications can be made to the described embodiments. The foregoing embodiments may be implemented individually or in any combination.

What is claimed is:

1. A window, comprising:

a tint layer having an adjustable tint; and
a haze layer having an adjustable haze.

2. The window of claim 1, wherein the tint layer is configured to exhibit a first tint and the haze layer is configured to exhibit a first haze in a first window state.

3. The window of claim 2, further comprising:

a plurality of window layers that have an appearance, wherein the tint layer and the haze layer are between some of the window layers, and wherein the window layers have a privacy appearance in the first window state.

4. The window of claim 3, wherein the tint layer is configured to exhibit the first tint and the haze layer is configured to exhibit a second haze in a second window state.

5. The window of claim 4, wherein the second tint is less than the first tint and the second haze is less than the first haze, and wherein the window layers have a dark appearance in the second window state.

6. The window of claim 1, wherein the tint layer comprises a light modulator device selected from the group consisting of: an electrochromic device, a guest-host liquid crystal device, a cholesteric liquid crystal device, and a suspended particle device.

7. The window of claim 1, wherein the haze layer comprises a polymer-dispersed liquid crystal device.

8. The window of claim 1, wherein the tint layer and the haze layer are independently adjustable.

9. The window of claim 1, further comprising:

a visible-light reflective layer having an adjustable reflectivity.

10. The window of claim 9, wherein the visible-light reflective layer comprises a cholesteric liquid crystal layer.

11. The window of claim 9, wherein the adjustable reflectivity is adjustable by at least 30%.

12. The window of claim 9, wherein the visible-light reflective layer and the haze layer are formed from a shared suspended particle device.

13. A window, comprising:

first and second window layers;

an adjustable haze layer between the first and second window layers; and

a polymer layer between the first and second window layers, and adjacent to the adjustable haze layer.

14. The window of claim 13, wherein the adjustable haze layer comprises a polymer-dispersed liquid crystal device that is adjustable between a first haze state and a second haze state.

15. The window of claim 14, wherein an index of refraction of the adjustable haze layer matches an index of refraction of the polymer layer in the first haze state, and wherein the index of refraction of the adjustable haze layer is different from the index of refraction of the polymer layer in the second haze state.

16. The window of claim 13, wherein the first and second window layers comprise glass.

17. The window of claim 13, further comprising:

an adjustable tint layer; and

an adjustable reflective layer.

18. A window, comprising:

a window layer;

an adjustable tint layer coupled to the window layer; and

an adjustable reflective layer coupled to the window layer.

19. The window of claim 18, wherein the adjustable reflective layer is configured to reflect visible light.

20. The window of claim **18**, wherein the adjustable tint layer is configured to be activated in a first mode, the adjustable reflective layer is configured to be activated in the first mode, and the adjustable tint layer and the adjustable reflective layer together form a one-way mirror in the first mode.

* * * * *