



(19) **United States**

(12) **Patent Application Publication**  
**Sylvester**

(10) **Pub. No.: US 2021/0222375 A1**

(43) **Pub. Date: Jul. 22, 2021**

(54) **MODULAR PAVEMENT SLAB**

(71) Applicant: **Integrated Roadways, LLC**, Kansas City, MO (US)

(72) Inventor: **Tim Sylvester**, Raytown, MO (US)

(73) Assignee: **Integrated Roadways, LLC**, Kansas City, MO (US)

(21) Appl. No.: **17/226,159**

(22) Filed: **Apr. 9, 2021**

**G01P 3/36** (2006.01)

**E01C 5/00** (2006.01)

**G01G 19/02** (2006.01)

**G01G 19/52** (2006.01)

(52) **U.S. Cl.**

CPC ..... **E01C 11/00** (2013.01); **G01M 5/0041**

(2013.01); **G01L 1/246** (2013.01); **G01L 17/00**

(2013.01); **G01G 3/125** (2013.01); **E01C**

**2201/00** (2013.01); **E01C 5/005** (2013.01);

**G01G 19/022** (2013.01); **G01G 19/025**

(2013.01); **G01G 19/52** (2013.01); **G01P 3/36**

(2013.01)

**Related U.S. Application Data**

(63) Continuation of application No. 16/528,024, filed on Jul. 31, 2019, now Pat. No. 10,995,457, which is a continuation of application No. 15/889,718, filed on Feb. 6, 2018, now Pat. No. 10,407,838.

(60) Provisional application No. 62/594,822, filed on Dec. 5, 2017, provisional application No. 62/455,287, filed on Feb. 6, 2017.

**Publication Classification**

(51) **Int. Cl.**

**E01C 11/00** (2006.01)

**G01M 5/00** (2006.01)

**G01L 1/24** (2006.01)

**G01L 17/00** (2006.01)

**G01G 3/12** (2006.01)

(57)

**ABSTRACT**

A modular pavement slab comprises a body, a strain sensor array, and a sensor processor. The body includes a top surface, a bottom surface, and four side surfaces. The modular pavement slab is configured to be coupled to at least one other modular pavement slab via connectors along at least one of the side surfaces. The strain sensor array is retained within the body and is configured to detect a plurality of strains on the body resulting from vehicular traffic across the top surface of the body. The sensor processor is in communication with the strain sensor array. The sensor processor is configured to communicate input signals to the strain sensor array, receive output signals from the strain sensor array, and determine a plurality of time-varying strain values, each strain value indicating a strain experienced over time by a successive one of a plurality of regions of the body.

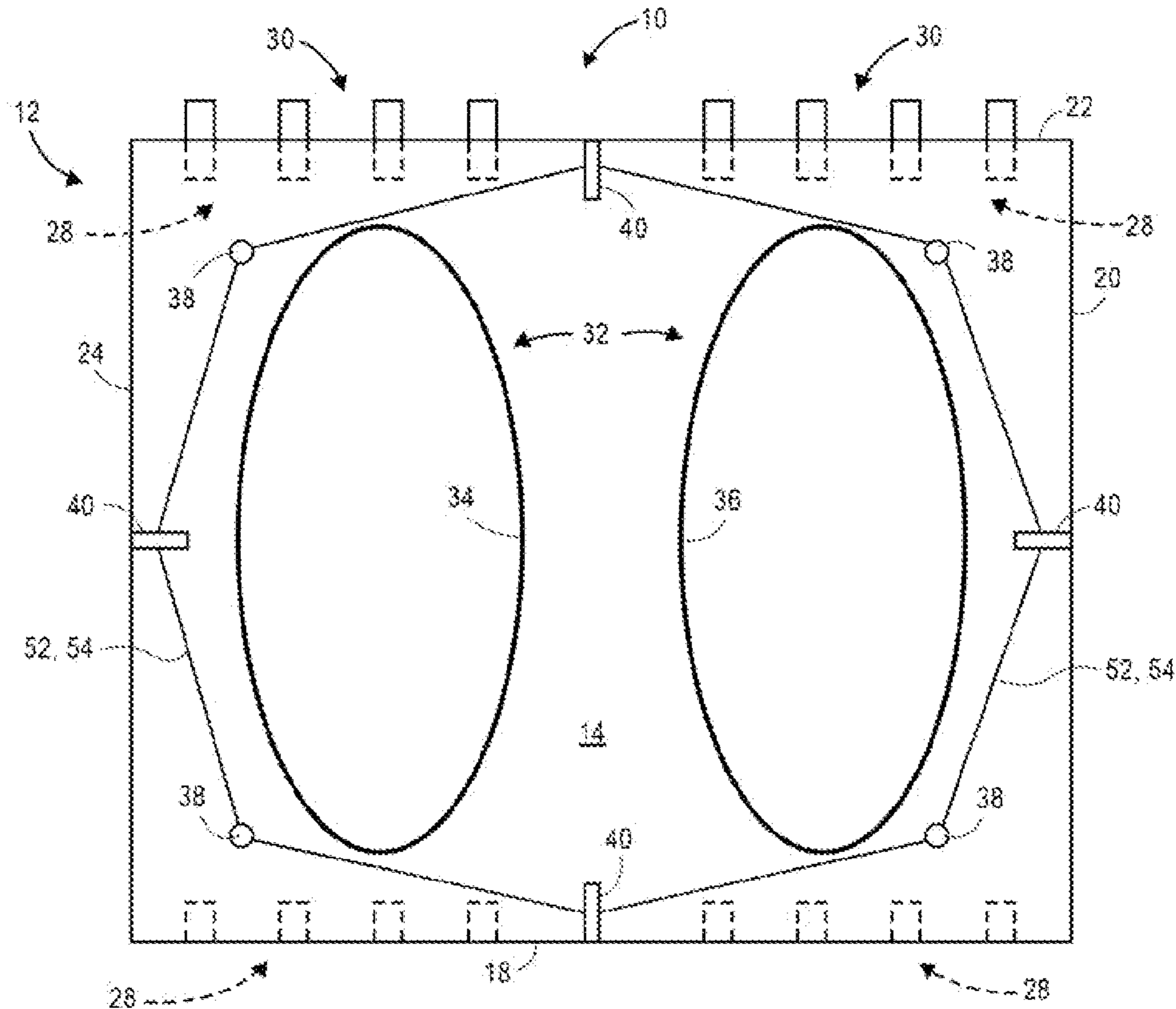

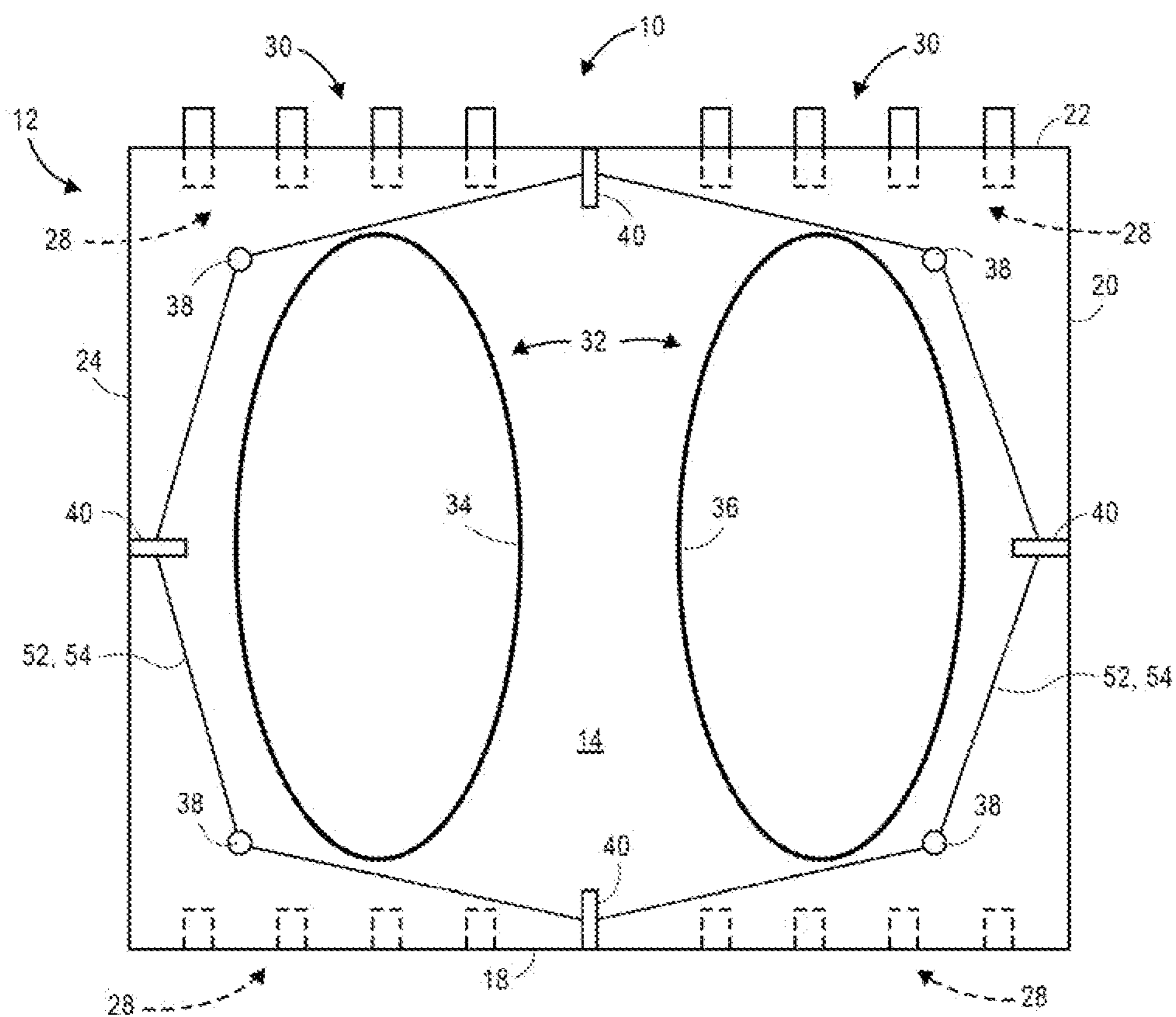

FIG. 1

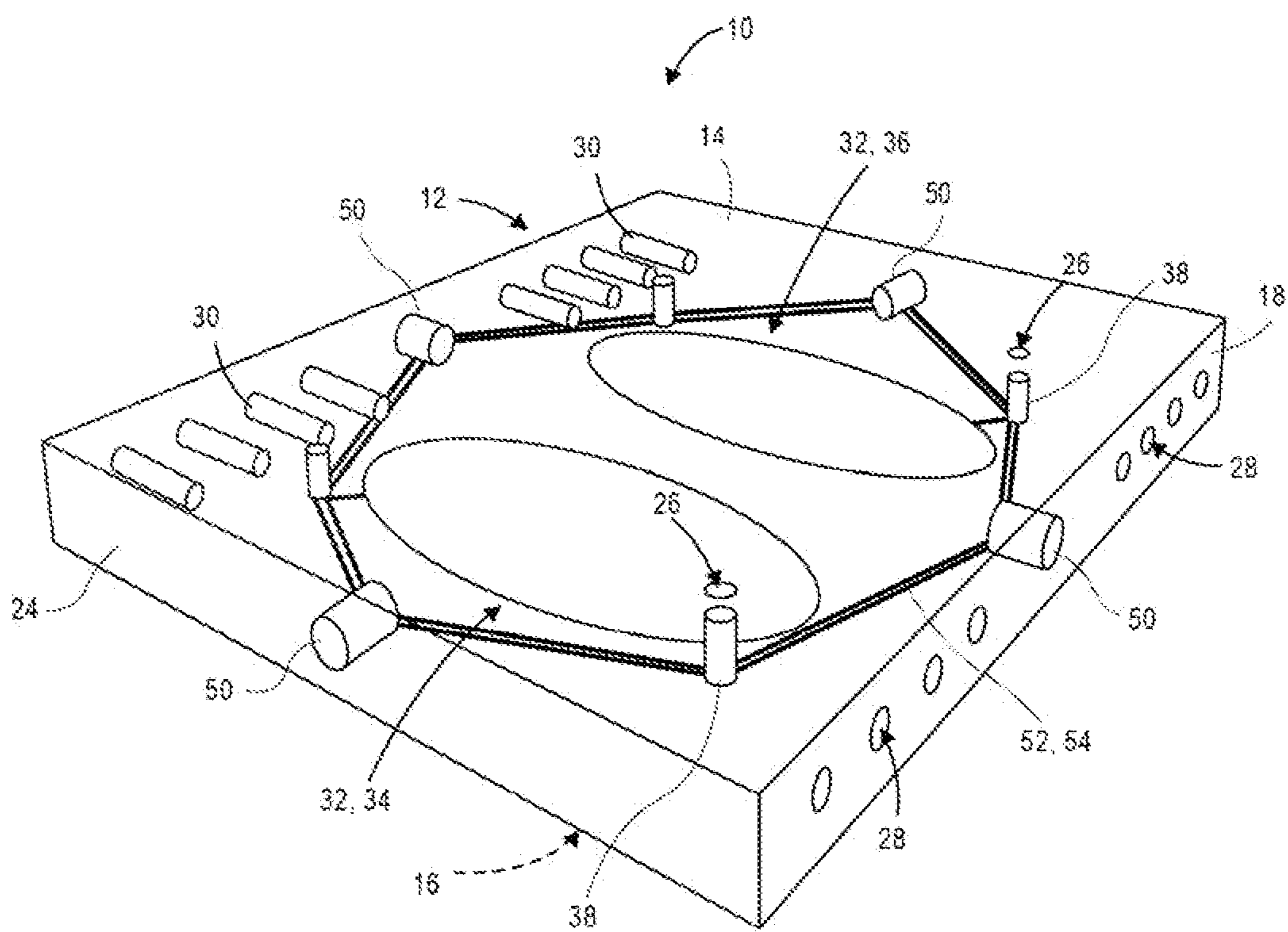

FIG. 2

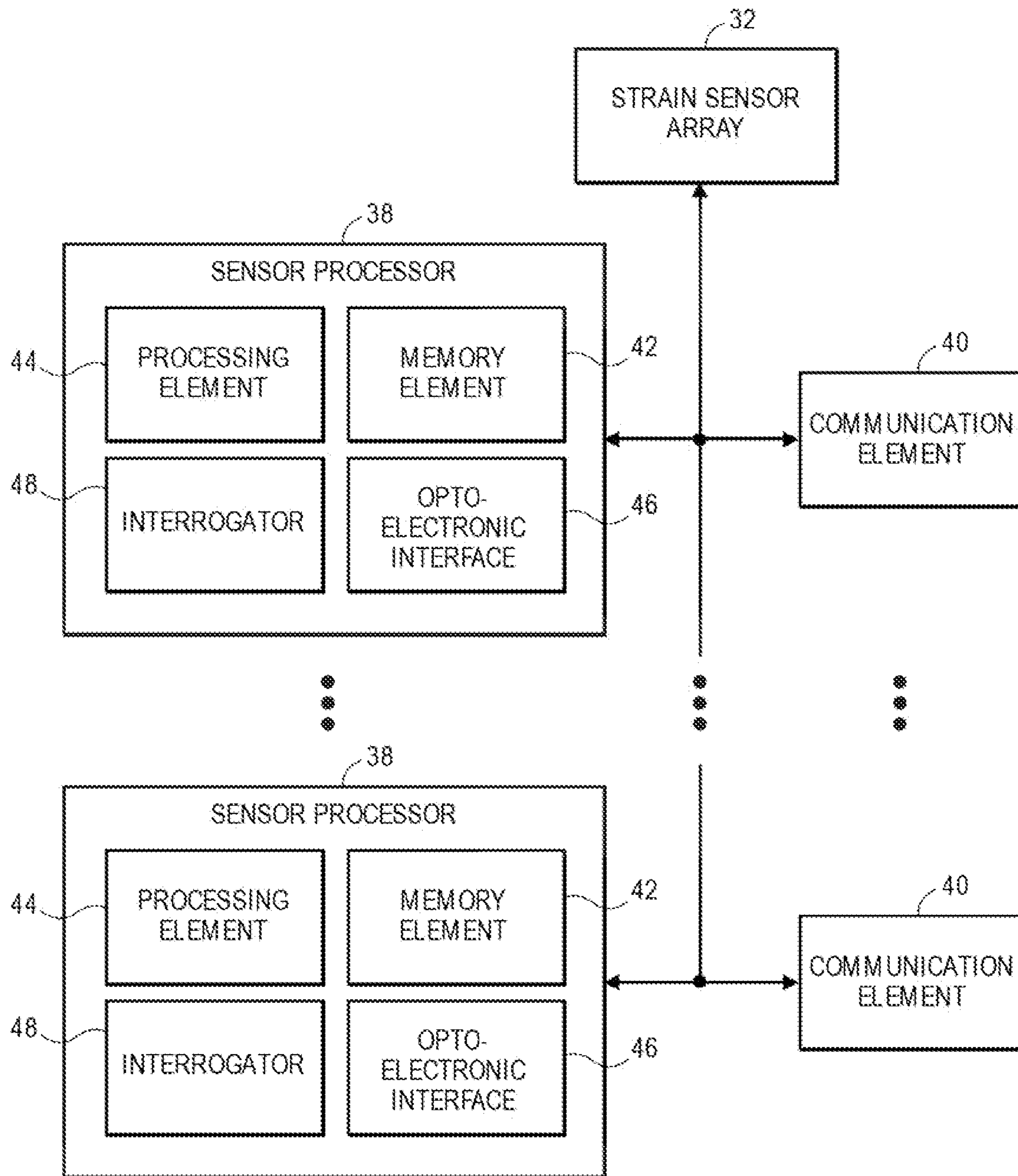

FIG. 3



## MODULAR PAVEMENT SLAB

### RELATED APPLICATION

**[0001]** The current patent application is a continuation patent application which claims priority benefit with regard to all common subject matter to identically-titled U.S. patent application Ser. No. 16/528,024, filed Jul. 31, 2019, which, itself, claims priority benefit with regard to all common subject matter to U.S. patent application Ser. No. 15/889,718, filed Feb. 6, 2018 (now U.S. Pat. No. 10,407,838), which, itself, claims priority benefit with regard to all common subject matter to the following identically-titled U.S. Provisional Applications: Application No. 62/455,287, filed Feb. 6, 2017; and Application No. 62/594,822, filed Dec. 5, 2017. Each of the earlier-filed provisional and non-provisional applications is hereby incorporated by reference in its entirety into the current application.

### BACKGROUND OF THE INVENTION

#### Field of the Invention

**[0002]** This invention relates generally to the field of pavement systems and, in particular, to a pre-fabricated, modular pavement slab equipped for embedded self-monitoring of form and integrity.

#### Description of the Related Art

**[0003]** Pre-fabricated, modular pavement slabs have traditionally offered an attractive alternative to continuous pour systems at least because they can be individually removed, repaired and/or replaced with relative ease. Traditional continuous pour systems require significantly more time and/or money for removal and replacement.

**[0004]** However, pre-fabricated, modular pavement slab systems have untapped potential for enabling focused, quick and low-cost maintenance and/or repair. For instance, defect detection for the slab and/or sub-grade is still overwhelmingly performed using the same traditional tools used in continuous pour systems. A serviceable modular pavement slab is needed to improve the longevity and usefulness of such alternatives to continuous pour systems.

### SUMMARY OF THE INVENTION

**[0005]** Embodiments of the current invention solve the above-mentioned problems and provide a distinct advance in the arts of modular pavement slabs that provide pavement condition indexing and vehicle position sensing.

**[0006]** An embodiment of the modular pavement slab comprises a body, a strain sensor array, and a sensor processor. The body includes a top surface. The strain sensor array is retained within the body and is configured to detect a plurality of strains on the body resulting from vehicular traffic across the top surface of the body. The sensor processor is in communication with the strain sensor array. The sensor processor is configured to communicate input signals to the strain sensor array, receive output signals from the strain sensor array, and determine a plurality of time-varying strain values, each strain value indicating a strain experienced over time by a successive one of a plurality of regions of the body.

**[0007]** This summary is provided to introduce a selection of concepts in a simplified form that are further described below in the detailed description. This summary is not

intended to identify key features or essential features of the claimed subject matter, nor is it intended to be used to limit the scope of the claimed subject matter. Other aspects and advantages of the current invention will be apparent from the following detailed description of the embodiments and the accompanying drawing figures.

### BRIEF DESCRIPTION OF THE DRAWING FIGURES

**[0008]** Embodiments of the current invention are described in detail below with reference to the attached drawing figures, wherein:

**[0009]** FIG. 1 is a top schematic view of a self-monitoring modular pavement slab according to the present inventive concept;

**[0010]** FIG. 2 is an elevated schematic view of the self-monitoring modular pavement slab of FIG. 1 illustrating a sensing body; and

**[0011]** FIG. 3 is a schematic block diagram of various electronic components of the self-monitoring modular pavement slab of FIG. 1.

**[0012]** The drawing figures do not limit the current invention to the specific embodiments disclosed and described herein. While the drawings do not necessarily provide exact dimensions or tolerances for the illustrated components or structures, the drawings are to scale as examples of certain embodiments with respect to the relationships between the components of the structures illustrated in the drawings.

### DETAILED DESCRIPTION OF THE EMBODIMENTS

**[0013]** The following detailed description of the invention references the accompanying drawings that illustrate specific embodiments in which the invention can be practiced. The embodiments are intended to describe aspects of the invention in sufficient detail to enable those skilled in the art to practice the invention. Other embodiments can be utilized and changes can be made without departing from the scope of the present invention. The following detailed description is, therefore, not to be taken in a limiting sense. The scope of the present invention is defined only by the appended claims, along with the full scope of equivalents to which such claims are entitled.

**[0014]** In this description, references to “one embodiment”, “an embodiment”, or “embodiments” mean that the feature or features being referred to are included in at least one embodiment of the technology. Separate references to “one embodiment”, “an embodiment”, or “embodiments” in this description do not necessarily refer to the same embodiment and are also not mutually exclusive unless so stated and/or except as will be readily apparent to those skilled in the art from the description. For example, a feature, structure, act, etc. described in one embodiment may also be included in other embodiments, but is not necessarily included. Thus, the current technology can include a variety of combinations and/or integrations of the embodiments described herein.

**[0015]** Prior art pre-cast slabs have long been recognized as an alternative to continuous pour solutions, which have been more popular traditionally within the United States. Part of the appeal offered by pre-cast paving systems is serviceability—when a portion of pavement requires service, it may be removed and replaced with relative ease as



compared with similar repair efforts using continuous pour solutions aimed at restoring the pavement to like-new condition. Nonetheless, defects within the body of a pavement slab and/or in the underlying sub-grade may exist for years prior to detection, which may lead to additional damage and more expensive repair efforts.

**[0016]** Embodiments of the present inventive concept improve existing detection methods and apparatus by providing a permanent, embedded form-monitoring system comprising a plurality of strain gauges distributed in an array across at least a portion of the length and width of each pre-cast slab. The array may be substantially continuous in nature—for example, where the array includes one or more fiber optic cables extending in a pattern throughout the slab—and may collect data at a plurality of strain detection points regarding the transfer of force through a sensing volume. The data collected from the strain detection points may be analyzed locally within each slab, using an adjacent system proximate to the slab, and/or transmitted to a remote database for analysis against data from neighboring slabs to detect developing defects in the sensing volume and/or underlying sub-grade. The data may also or alternatively be put to additional uses, including vehicle monitoring providing positional data, vehicle weights, speeds, axle widths, axle lengths, traffic patterns, vehicle behaviors, and other information that can be detected through monitoring the internal and external deformations of the pavement slab.

**[0017]** Collection of data regarding changes over time in how a segment and its surrounding segments within the sensing volume transfer forces therethrough may permit modeling of sufficient resolution to detect defects in the paving apparatus and/or in the underlying sub-grade. Moreover, accelerations, gyroscopic motion, magnetic fields, temperature, salinity, water content and additional properties may be detected within each slab to enhance data resolution and permit easier identification of changes in slab form and/or integrity and/or to monitor atmospheric or environmental conditions.

**[0018]** Turning to FIGS. 1-2, a pre-cast, self-monitoring modular pavement slab **10** according to an embodiment of the present inventive concept broadly comprises a body **12** generally having a rectangular box shape with an upper surface **14**, a bottom surface **16**, and four side surfaces **18**, **20**, **22**, **24**. The body **12** may be composed primarily of precast concrete pavement. The body **12** may also or alternatively comprise asphalt, plastic material, fiberglass, carbon fiber, geopolymers and/or other materials that may serve as and/or support driving surfaces without departing from the spirit of the present inventive concept.

**[0019]** The modular pavement slab **10** may include a plurality of access ports **26** defined in and below the upper surface **14** (it should be noted that the third and fourth access ports are not illustrated in FIG. 2 to avoid obscuring other components). The access ports **26** may house embedded lifting receivers (not shown) and are spaced for balanced lifting of the body **12**. Access ports may also permit fluid communication between upper and bottom surfaces and may be configured to house and/or provide access to other sensing equipment (see incorporations by reference below) without departing from the spirit of the present invention.

**[0020]** Two opposing side surfaces **18**, **22** define dowel cavities **28** therein that extend within and toward the center of the body **12**. Dowel rods **30** may extend at least partway out of the cavities **28**—for example where the modular

pavement slab **10** is assembled to neighboring structures such as other paving apparatus—and each may be secured in place within the slab and/or a neighboring structure, following assembly, using grouting or the like.

**[0021]** It is foreseen that additional of the substantially vertical side surfaces or faces of a body may include dowel cavities and rods without departing from the spirit of the present inventive concept. It is also foreseen that other load-transferring structure may be used in lieu of or in addition to dowel rods without departing from the spirit of the present inventive concept. A rubber skirt, backer board, spacing rod, tar mixture, grouting or similar buffering substance may also be placed in seams between a modular pavement slab and neighboring structures and/or below the modular pavement slab. A modular pavement slab preferably also includes an internal reinforcement grid (not shown), which may be comprised of at least two layers of steel rebar lattice or other known internal reinforcement structures such as fiberglass reinforcement mat, geotechnical mat, carbon fiber mat, or loose reinforcement material such as fiberglass fibers, carbon fibers, plastic fibers, or metallic shavings. More broadly, it is foreseen that embodiments of the present inventive concept are interoperable with the paving systems and apparatuses described in U.S. Patent Publication No. 2016-0222594 A1 to Sylvester and in U.S. Patent Publication No. 2017-0191227 A1 to Sylvester, each of which is hereby incorporated by reference herein in its entirety.

**[0022]** The modular pavement slab **10** also includes a strain sensor array **32** distributed at least partly across the length and width of body **12**. Strain sensor array **32** includes a plurality of optical fiber sensors. In the exemplary embodiments shown in the figures, the strain sensor array **32** includes first and second optical fiber sensors **34**, **36**. Each optical fiber sensor **34**, **36** may include optical fiber sensing technologies including but not limited to one or more methods such as Rayleigh, Brillouin, Raman, or Fiber Bragg Grating (FBG) technologies, distributed along the length thereof. In the described method using FBGs, the FBGs are positioned in the optical fiber with selectable space therebetween. Each FBG, or any other method implemented as described above but not limited to those specifically named, provides a measurement of the strain of its surrounding environment, which is a local volume or region of the body **12**. Alternatively, or additionally, each optical fiber sensor **34**, **36** may include a plurality of individually packaged FBGs coupled to one another with a plurality of optical fibers, with each optical fiber coupling two FBGs. Generally, each FBG reflects an optical signal, of a particular wavelength or small band of wavelengths, that it receives. The characteristics, such as intensity, amplitude, wavelength, and/or time delay, of the optical signal reflection may vary according to a strain, potentially among other factors, placed on the FBG.

**[0023]** The optical fiber sensors **34**, **36** are shown in the figures to be implemented with a circular or oval layout within the body **12**. However, the optical fiber sensors **34**, **36** may be implemented within the body **12** in a serpentine pattern layout, a coil pattern layout, a grid pattern, an array of individual fiber optic lines, or other geometric pattern layouts. In addition, the first optical fiber sensor **34** may have a first layout, while the second optical fiber sensor **36** may have a second layout. The optical fiber sensors **34**, **36** are also shown to occupy separate regions of the body **12**. In



other embodiments, the optical fiber sensors **34**, **36** may overlap one another, for example along the depth or height of the body **12**, or may otherwise occupy the same region of the body **12** within a given plane. While the drawings demonstrate two fibers, a plurality of fibers may be incorporated into the functional unit incorporating one or more fiber patterns, or fiber optic sensing methods, within the body of a slab.

**[0024]** The positioning of the FBGs or alternative sensing elements of other sensing methods within each optical fiber may be selected in combination with the layout of each optical fiber sensor **34**, **36** to establish a desired resolution of the strain measurements throughout the volume of the body **12** (e.g., within the boundaries of the body **12** illustrated in FIG. 2) and/or with respect to the surface area of the upper surface **14** of the body **12**. For example, a smaller spacing between FBGs within the optical fiber sensors **34**, **36** produces a greater resolution of strain measurements, while a larger spacing leads to lower resolution. In addition, layout patterns of the optical fiber sensors **34**, **36** such as a serpentine or coil produces a greater resolution of strain measurements, while patterns such as a circle provide lower resolution.

**[0025]** In an embodiment, a strain sensor array may include at least three optical fiber sensors (not shown) arranged in a linear layout and positioned within a slab along the length thereof. In such embodiments, each optical fiber sensor may extend along a majority of the length of the slab and be positioned in proximity to, and association with, a wheel path of vehicles travelling on a corresponding apparatus. For example, a first and a second optical fiber sensor may be placed closer to outer edges of the slab along the wheel paths of most automobiles and trucks. A third optical fiber sensor may be placed close to the center of the slab along the wheel path of a motorcycle. It is foreseen, however, that in certain embodiments strain sensor arrays may include a plurality of strain sensors distributed across a portion of the length and width of the paving apparatus without departing from the spirit of the present inventive concept. One of ordinary skill will also appreciate that arrays including solid-state strain gauges, vibrating wire strain gauges, load cells, piezo-electric elements and/or similar known sensors are within the scope of the present invention.

**[0026]** While it is foreseen that embodiments of the present inventive concept may be constructed in the field or on site—for example as part of a cast-in-place installation—or be pre-fabricated into an assembly that can be installed into alternative paving materials such as asphalt or cast-in-place concrete, it is preferred that the strain sensor array **32** be encased and permanently fixed within body **12** during an offsite pre-fabrication process. The optical fiber sensors **34**, **36** may be laminated and/or fixed to a top side of a bottommost reinforcement layer (not shown, but see, e.g., FIGS. 2-4 of U.S. Patent Publication No. 20170191227A1) of the modular pavement slab **10** during fabrication, essentially extending in a substantially horizontal plane at a given height within the body **12**. Placement near the bottom of the body **12** may provide greater resolution from and/or amplification of data collected by the strain sensor array **32**. Moreover, fixing the strain sensor array **32** to a reinforcement layer may generate a more holistic data set representing changes in form across the entire body **12** because a preferred reinforcement layer will extend across substantially the entire length and width of the body **12** and may be

less susceptible to localized distortions resulting from pockets or imperfections in the body **12**.

**[0027]** It is foreseen that all or portions of a strain sensor array may be encased at different and/or varying heights within a slab without departing from the spirit of the present inventive concept. For instance, disposing at least one sensor at a different height within the slab—such as vertically above or below a second sensor—may provide additional resolution for detecting defects in the slab. However, long dimensions of optical fiber sensors are preferably in substantial alignment with a direction of travel, for example along a length axis, which may improve detection of vehicular load progression across a top surface of the slab.

**[0028]** The modular pavement slab **10** also may include at least one sensor processor **38** and at least one communication element **40** to provide signal control and processing as well as communication, as shown in FIG. 3. The sensor processor **38** includes a memory element **42**, a processing element **44**, and an optoelectronic interface **46**. Each sensor processor **38** may be retained within a housing that is accessible through a successive one of the access ports **26**. In addition, each sensor processor **38** may be removable and replaceable, and access for such removal may be protected by a keyed security device—such as an interlock connecting the housing to the body **12** and requiring a special tool to disconnect—and/or grouting or the like.

**[0029]** The memory element **42** may be embodied by devices or components that store data in general, and digital or binary data in particular, and may include exemplary electronic hardware data storage devices or components such as read-only memory (ROM), programmable ROM, erasable programmable ROM, random-access memory (RAM) such as static RAM (SRAM) or dynamic RAM (DRAM), cache memory, hard disks, floppy disks, optical disks, flash memory, thumb drives, universal serial bus (USB) drives, or the like, or combinations thereof. In some embodiments, the memory element **42** may be embedded in, or packaged in the same package as, the processing element **44**. The memory element **42** may include, or may constitute, a “computer-readable medium”. The memory element **42** may store the instructions, code, code statements, code segments, software, firmware, programs, applications, apps, services, daemons, or the like that are executed by the processing element **44**. The memory element **42** may also store settings, data, databases, and the like.

**[0030]** The processing element **44** may include electronic hardware components such as processors, microprocessors (single-core or multi-core), microcontrollers, digital signal processors (DSPs), field-programmable gate arrays (FPGAs), analog and/or digital application-specific integrated circuits (ASICs), or the like, or combinations thereof. The processing element **44** may generally execute, process, or run instructions, code, code segments, code statements, software, firmware, programs, applications, apps, processes, services, daemons, or the like. The processing element **44** may also include hardware components such as finite-state machines, sequential and combinational logic, and other electronic circuits that can perform the functions necessary for the operation of the current invention. The processing element **44** may be in communication with the other electronic components through serial or parallel links that include universal busses, address busses, data busses, control lines, and the like.



[0031] The optoelectronic interface 46 generally converts electronic signals to optical signals and vice versa. The optoelectronic interface 46 may include photonic generator (s), such as light-emitting diodes (LEDs), lasers including top emitters, edge emitters, or the like, as well as photodetectors, such as photodiodes, phototransistors, photoresistors, phototubes, or the like. The optoelectronic interface 46 may further include electronic circuitry such as amplifiers, filters, analog-to-digital converters (ADCs), digital-to-analog converters (DACs), and so forth. The optoelectronic interface 46 receives electronic signals and converts them to transmitted optical signals, i.e., electromagnetic radiation having a plurality of wavelengths in the visible and/or infrared regions of the electromagnetic spectrum. The optical signals correspond to the electronic signals in amplitude, frequency, and duration. The optoelectronic interface 46 receives optical signals and converts them to generated electronic signals having a voltage level, current level, power level, or the like corresponding to the optical signals in amplitude, frequency, and duration. The optoelectronic interface 46 may also generate an electronic data stream that corresponds to the received optical signals.

[0032] Through hardware, firmware, software, or various combinations thereof, the sensor processor 38 may be configured or programmed to perform at least the following functions. The sensor processor 38 generally controls the operation of the strain sensor array 32 by generating the input signals and communicating them to the strain sensor array 32 and receiving and processing the output signals of the strain sensor array 32. In some embodiments, a single sensor processor 38 may be coupled to and control the operation of both optical fiber sensors 34, 36. In other embodiments, the modular pavement slab 10 may include multiple sensor processors 38, each coupled to and controlling the operation of a respective one of the optical fiber sensors 34, 36. The sensor processor 38 further includes an interrogator 48 as a function of the processing element 44 or as a separate component. In some embodiments, the interrogator 48 may further include, or be in electronic communication with, the optoelectronic interface 46. Utilizing the interrogator 48, the sensor processor 38 generates a plurality of optical signals, each having a unique wavelength, which are transmitted through the optical fiber sensors 34, 36. The optical signals may be transmitted simultaneously or sequentially. The parameters of the optical signals transmitted by the sensor processor 38 may be selectively programmable.

[0033] In the illustrated embodiment, all of the optical signals are received by each FBG in the optical fiber sensors 34, 36. But, each FBG may reflect only the optical signal whose wavelength is the same as the one the FBG is designed to reflect. Furthermore, the characteristics of the reflected optical signal, such as intensity change, amplitude change, time delay, and/or shifted wavelength, may vary according to the strain experienced by the FBG, thus providing a measurement of the strain on the body 12 in the local volume surrounding the FBG. The sensor processor 38 receives all of the reflected optical signals and analyzes them to determine the strain at each location of an FBG. In addition, the sensor processor 38 repeats this process dozens or hundreds of times per second.

[0034] The sensor processor(s) 38 may create a virtual database or table of measured strain values that is stored in the memory element 42. The virtual database may include a plurality of historically-recorded strain values for each FBG. Since the X and Y coordinate locations (with respect to the

upper surface 14 of the body 12) of each FBG are known, the sensor processor 38 may create a time-varying virtual map of strain values experienced by the body 12 resulting from the weight or mass of vehicles travelling across the upper surface 14 thereof—each strain value indicating a strain experienced over time by a successive one of a plurality of regions of the body 12. In addition, utilizing the change in strain along a particular path or in certain areas, such as vehicle wheel paths, the sensor processor 38 can determine a velocity vector, i.e., a speed and direction, of the vehicles traversing the upper surface 14. Furthermore, the sensor processor 38 may utilize a lookup table or machine learning or artificial intelligence techniques to determine a type of vehicle that is traversing the upper surface 14 based on dynamic characteristics, such as a magnitude of change in amplitude, of the measured strain values.

[0035] The communication element 40 generally allows communication with external systems or devices. The communication element 40 may include signal and/or data transmitting and receiving circuits, such as antennas, amplifiers, filters, mixers, oscillators, digital signal processors (DSPs), and the like. The communication element 40 may establish communication wirelessly by utilizing radio frequency (RF) signals and/or data that comply with communication standards such as cellular 2G, 3G, 4G, LTE, or 5G, Institute of Electrical and Electronics Engineers (IEEE) 802.11 standard such as WiFi, IEEE 802.16 standard such as WiMAX, Bluetooth™, or combinations thereof. In addition, the communication element 40 may utilize communication standards such as ANT, ANT+, Bluetooth™ low energy (BLE), the industrial, scientific, and medical (ISM) band at 2.4 gigahertz (GHz), commercially available or customized Radio Frequency Identification (RFID), or the like. Alternatively, or in addition, the communication element 40 may establish communication through connectors or couplers that receive metal conductor wires or metal conductor cables which are compatible with networking technologies such as ethernet. In certain embodiments, the communication element 40 may also couple with optical fiber cables.

[0036] In some embodiments, the modular pavement slab 10 may include a single communication element 40 that is in electronic communication with the one or more sensor processors 38. In other embodiments, the modular pavement slab 10 may include a plurality of communication elements 40, each communication element 40 in electronic communication with a respective one of the sensor processors 38. In any case, the communication element 40 may receive measured strain values, velocity data, and vehicle data from one or more of the sensor processors 38 and communicate the data to other sensor processors 38 in the same modular pavement slab 10 or other slabs 10 or external devices or systems, such as through Bluetooth™, WiFi, and/or cellular protocols. The communication element 40 may also receive programming data or instructions for the sensor processors 38 to operate the strain sensor array 32 from external devices or systems or other apparatuses 10. The programming and instructions may be communicated to the appropriate sensor processors 38.

[0037] In various embodiments, the modular pavement slab 10 further includes a plurality of communication ports 50. Each communication port 50 may include a plurality of electrical and/or optical connectors. Each of the connectors, whether electrical or optical, may couple directly with a corresponding connector on the communication port 50 of another modular pavement slab 10 or with electrical cables or optical fibers that couple to other communication ports 50. Each communication port 50 is positioned on a succes-



sive one of the four side surfaces **18**, **20**, **22**, **24** of the body **12**, typically close to the center of the side surface, such that, when the apparatuses **10** are placed next to one another to form a road, the communication port **50** of one modular pavement slab **10** aligns with, and may couple to, the communication port **50** of its adjacent modular pavement slab **10**. In addition, each communication port **50** is in electronic communication with one or more communication elements **40** to enable communication of measured strain values, velocity data, and vehicle data from one or more of the sensor processors **38**.

**[0038]** The modular pavement slab **10** also includes data and/or power lines **52**, **54** extending between sensor processors **38** and communication elements **40**. It is foreseen that the illustrated pattern of wired connection between electronics of the modular pavement slab **10** may vary, and/or that wireless communication routers may be used, without departing from the spirit of the present inventive concept. It is also foreseen that lines, cables and/or wires described herein for data and/or power transfer may comprise a variety of materials—including cable, fiber and wires of various materials—without departing from the spirit of the present inventive concept.

**[0039]** In operation, as a load is applied to upper surface **14**, the applied force may propagate through segments of the sensing volume, creating temporary (and, possibly, permanent) deformations in the material of body **12**. As the propagating force deforms areas surrounding the strain sensor array **32**, strains are sensed by the optical fiber sensors **34**, **36** and determined by one or more sensor processors **38**. The time-varying measured strain data may be recorded and stored in one or more memory elements **42** and utilized to determine the presence and/or location of vehicles on the upper surface **14**, as well as their orientations, directions, speeds, weights, tire pressures, and other data points which may be derived from such strain distributions.

**[0040]** Loads on the sensing volume of the body **12** may be continuously sensed over long periods of time, with significant localized variances in how forces move through segments of the sensing volume being noted as potentially indicative of defects in and/or damage to body **12** and/or the underlying sub-grade. Such data may be transmitted remotely for further processing against data gathered from surrounding slabs, which may provide further clarity regarding the potential cause(s) of irregularity, for example by providing relative control groups of how nearby slabs are reacting to loads. Sensor data may also or alternatively be analyzed locally and/or remotely in real time for use by navigation (e.g., autonomous) guidance systems, emergency alert and car deviation systems, and for other uses. Data obtained from the strain sensor array **32** may also be used to measure internal and applied loads, deflection, 3D shape, moisture content and/or temperature. The data may be analyzed to indicate vehicle location, orientation, speed, weight, and the like.

**[0041]** For instance, the communication elements **40** may establish direct and/or indirect communication(s) with vehicles for transmitting raw and/or processed data collected via the strain sensor array **32**. Such data may be used in connection with autonomous and/or self-driving technologies (e.g., Level 4 autonomous driving). In an embodiment, one or more of the communication elements **40** may continuously or periodically transmit such data—i.e., regarding objects and/or vehicles present on the slab **10** (e.g., position, velocity, weight, etc.)—to one or more autonomous vehicles to support automated navigation. In a more particular

embodiment, data obtained via the strain sensor arrays **32** of a system of slabs **10** may comprise and/or be integrated into vehicular location, positioning, navigation, telemetry, or obstacle avoidance systems to provide and/or improve accuracy of positional data in support of autonomous driving operations.

**[0042]** In addition, the communication elements **40** may receive data and/or information from vehicles implementing autonomous and/or self-driving technologies that are in the vicinity of, or traveling upon, the associated slab **10**. The data and/or information may include velocity and/or heading information, vehicle identification information, and the like. The data and/or information may be utilized by the slab **10** for verification purposes, fault detection or correction purposes, and the like. Additionally, or alternatively, the data and/or information may be transferred to other slabs **10** in the vicinity or in the direction of travel of the vehicle.

**[0043]** It should also be noted that a benefit of the illustrated embodiment, while not required to practice the present inventive concept, is multiple redundancies. For instance, first and second optical fiber sensors **34**, **36** may permit operation, albeit with potentially reduced data resolution, even in the event one fails. Moreover, the multiple sensor processors **38** may redundantly include interrogators **48** and/or electrical communication with the optical fiber sensors **34**, **36** such that failure of a single sensor processor **38** does not necessarily lead to loss of any output from the strain sensor array **32**. In the same vein, multiple communication elements **40** may also provide several data outputs (and, preferably, inputs) that may increase the longevity of each modular pavement slab **10** by providing alternative access points in the event of a single communication element **40** failure.

**[0044]** Having now described the features, discoveries and principles of the general inventive concept, the manner in which the general inventive concept is constructed and used, the characteristics of the construction, and advantageous, new and useful results obtained; the new and useful structures, devices, tools, elements, arrangements, parts and combinations, are set forth in the appended claims.

**[0045]** It is also to be understood that the following claims are intended to cover all of the generic and specific features of the general inventive concept herein described, and all statements of the scope of the general inventive concept which, as a matter of language, might be said to fall therebetween.

**[0046]** Although the invention has been described with reference to the embodiments illustrated in the attached drawing figures, it is noted that equivalents may be employed and substitutions made herein without departing from the scope of the invention as recited in the claims.

**[0047]** Having thus described various embodiments of the invention, what is claimed as new and desired to be protected by Letters Patent includes the following:

1. A system comprising:

- a modular pavement slab having a body including a top surface, a bottom surface, and a plurality of side surfaces, the modular pavement slab being configured to be coupled to a second modular pavement slab via load-transferring connectors along at least one of the plurality of side surfaces;
- a strain sensor array contacting the body, the strain sensor array configured to detect a plurality of strains on the body resulting from traffic across the top surface of the body;



a sensor processor configured to—  
 receive output signals from the strain sensor array,  
 determine a plurality of strain values based at least in part on the output signals from the strain sensor array, each strain value indicating a strain of the plurality of strains experienced by a region of the body; and  
 a plurality of cavities defined by the body;  
 said load-transferring connectors extending from a first side surface of the plurality of side surfaces,  
 said plurality of cavities extending into the body from a second side surface of the plurality of side surfaces.

**2.** The system of claim **1**, wherein the strain sensor array includes first and second optical fiber sensors, each optical fiber sensor including an optical fiber with a plurality of fiber Bragg gratings spaced apart axially along the optical fiber.

**3.** The system of claim **2**, wherein each optical fiber sensor forms a loop and the first optical fiber sensor is positioned adjacent to the second optical fiber sensor within the body.

**4.** The system of claim **1**, wherein the sensor processor is further configured to determine a speed and a direction of each vehicle that travels across the top surface of the modular pavement slab.

**5.** The system of claim **1**, wherein the sensor processor is further configured to determine a weight of each vehicle that travels across the top surface of the body.

**6.** The system of claim **1**, wherein the sensor processor is further configured to determine a tire pressure of each tire of each vehicle that travels across the top surface of the body.

**7.** The system of claim **1**, wherein the sensor processor is further configured to determine a type of each vehicle that travels across the top surface of the body.

**8.** The system of claim **1**, further comprising a communication element in electronic communication with the sen-

sor processor and configured to communicate information derived from the strain values to other modular pavement slabs or external systems.

**9.** The system of claim **1**, wherein the sensor processor is housed or embedded in the body of the modular pavement slab.

**10.** The system of claim **1**, wherein the modular pavement slab includes a reinforcement layer and the strain sensor array is attached to the reinforcement layer.

**11.** The system of claim **1**, wherein the strain sensor array is embedded in the body of the modular pavement slab.

**12.** The system of claim **11**, wherein the strain sensor array comprises a first optical fiber sensor embedded in a bottom half of the modular pavement slab.

**13.** The system of claim **1**, wherein the strain sensor array comprises a first optical fiber sensor having a long dimension extending in a direction of travel.

**14.** The system of claim **1**, further comprising an access port defined by the body in and below the top surface.

**15.** The system of claim **14**, wherein the sensor processor is accessible via the access port.

**16.** The system of claim **1**, wherein the strain sensor array comprises first and second optical fiber sensors embedded at different heights within the body relative to the top and the bottom surfaces.

**17.** The system of claim **1**, wherein the output signals are generated in response to input signals communicated to the strain sensor array by the sensor processor.

**18.** The system of claim **1**, wherein the second side surface is substantially opposite from the first side surface.

**19.** The system of claim **1**, wherein the plurality of strain values comprise time-varying strain values.

**20.** The system of claim **1**, further comprising a connector positioned along one of the plurality of side surfaces configured for electronic communication with a second connector of the second modular pavement slab.

\* \* \* \* \*