



(19) **United States**

(12) **Patent Application Publication**  
**Cui et al.**

(10) **Pub. No.: US 2021/0104730 A1**

(43) **Pub. Date: Apr. 8, 2021**

(54) **ELECTRODE INCLUDING  
NANOSTRUCTURES FOR RECHARGEABLE  
CELLS**

(71) Applicant: **Amprius, Inc.**, Fremont, CA (US)

(72) Inventors: **Yi Cui**, Stanford, CA (US); **Song Han**,  
Foster City, CA (US); **Mark C.**  
**Platshon**, Menlo Park, CA (US)

(21) Appl. No.: **16/949,201**

(22) Filed: **Oct. 19, 2020**

**Related U.S. Application Data**

(63) Continuation of application No. 16/109,609, filed on Aug. 22, 2018, now Pat. No. 10,811,675, which is a continuation of application No. 13/427,681, filed on Mar. 22, 2012, now Pat. No. 10,090,512, which is a continuation of application No. 12/437,529, filed on May 7, 2009, now abandoned.

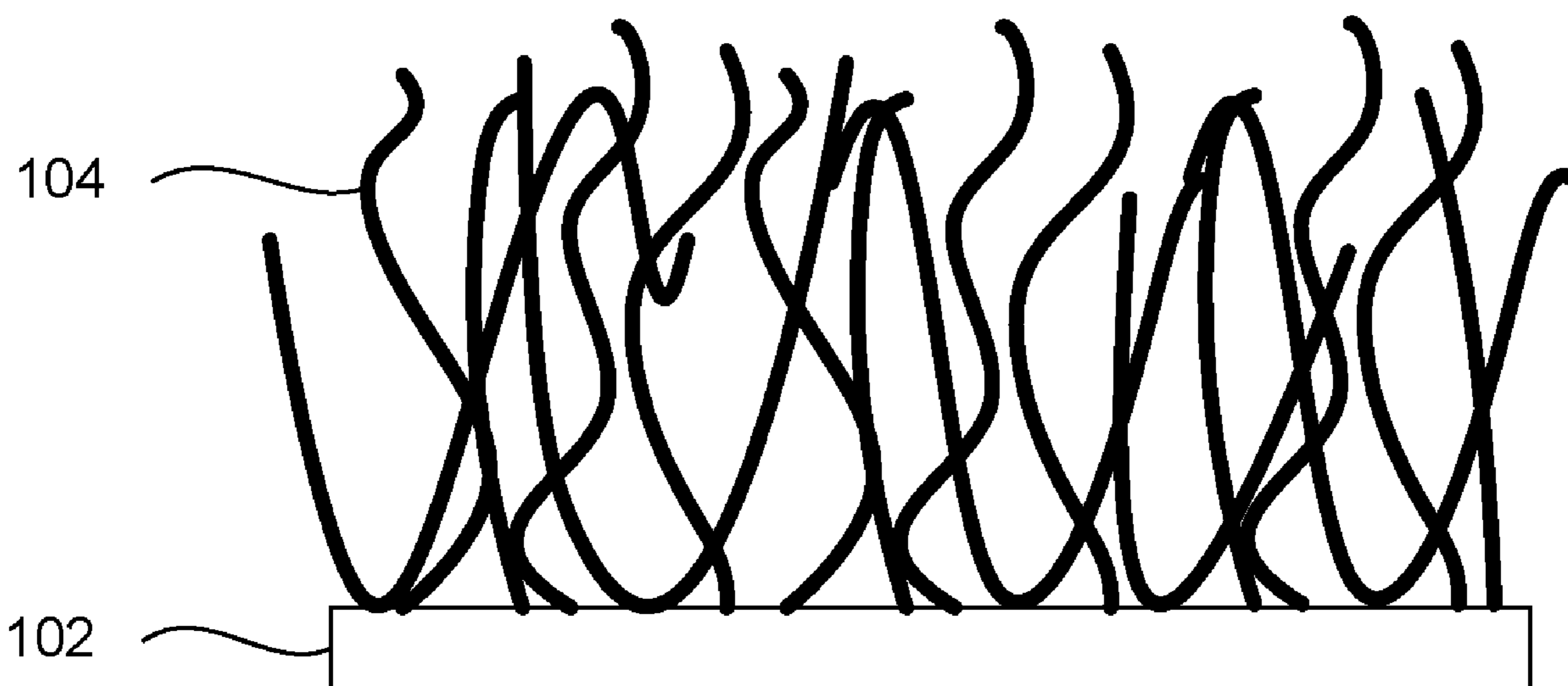
**Publication Classification**

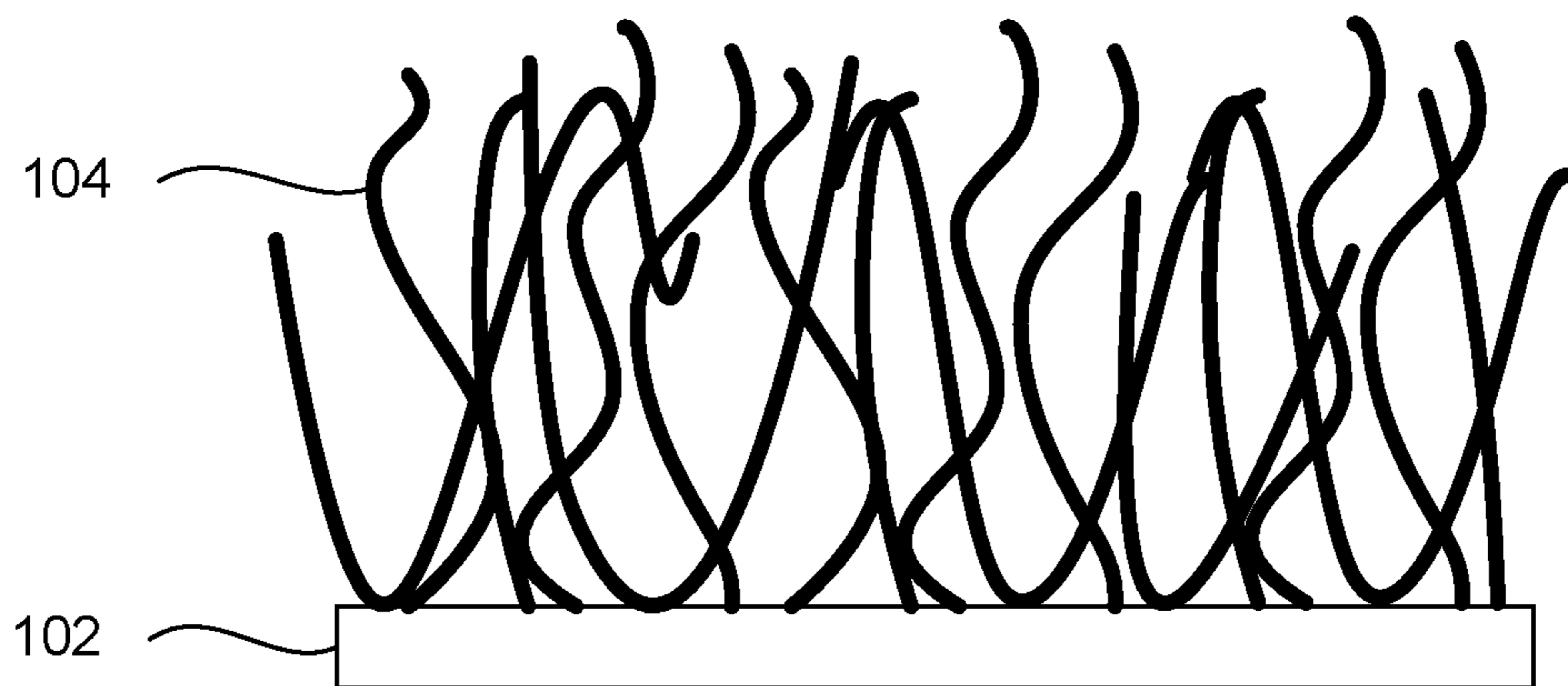
(51) **Int. Cl.**  
*H01M 4/134* (2006.01)  
*H01M 4/1395* (2006.01)  
*H01M 4/36* (2006.01)  
*H01M 4/66* (2006.01)  
*H01M 4/75* (2006.01)

(52) **U.S. Cl.**  
 CPC ..... *H01M 4/134* (2013.01); *H01M 4/1395* (2013.01); *H01M 4/366* (2013.01); *H01M 2004/022* (2013.01); *H01M 4/663* (2013.01); *H01M 4/75* (2013.01); *Y10T 29/49108* (2015.01); *H01M 4/661* (2013.01)

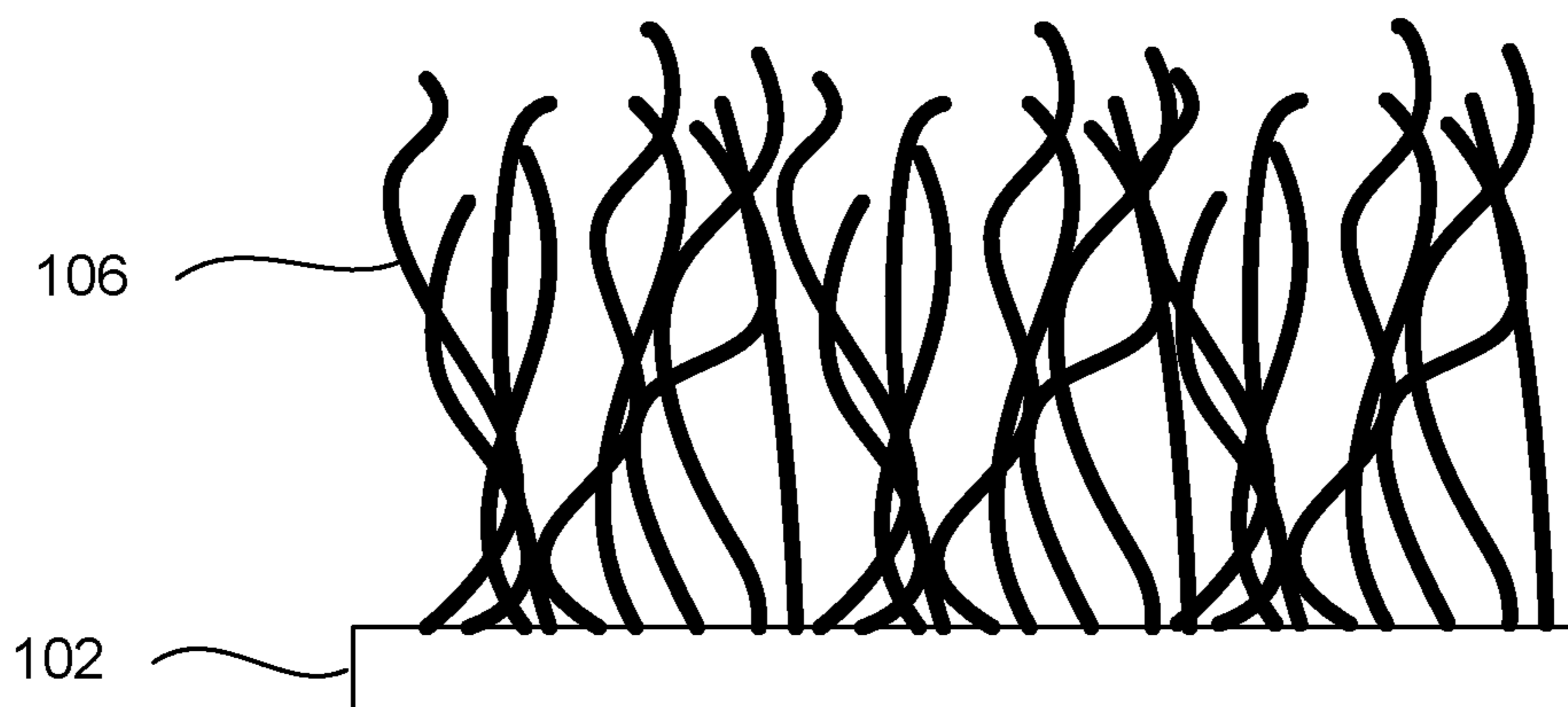
**ABSTRACT**

(57) A lithium ion battery electrode includes silicon nanowires used for insertion of lithium ions and including a conductivity enhancement, the nanowires growth-rooted to the conductive substrate.

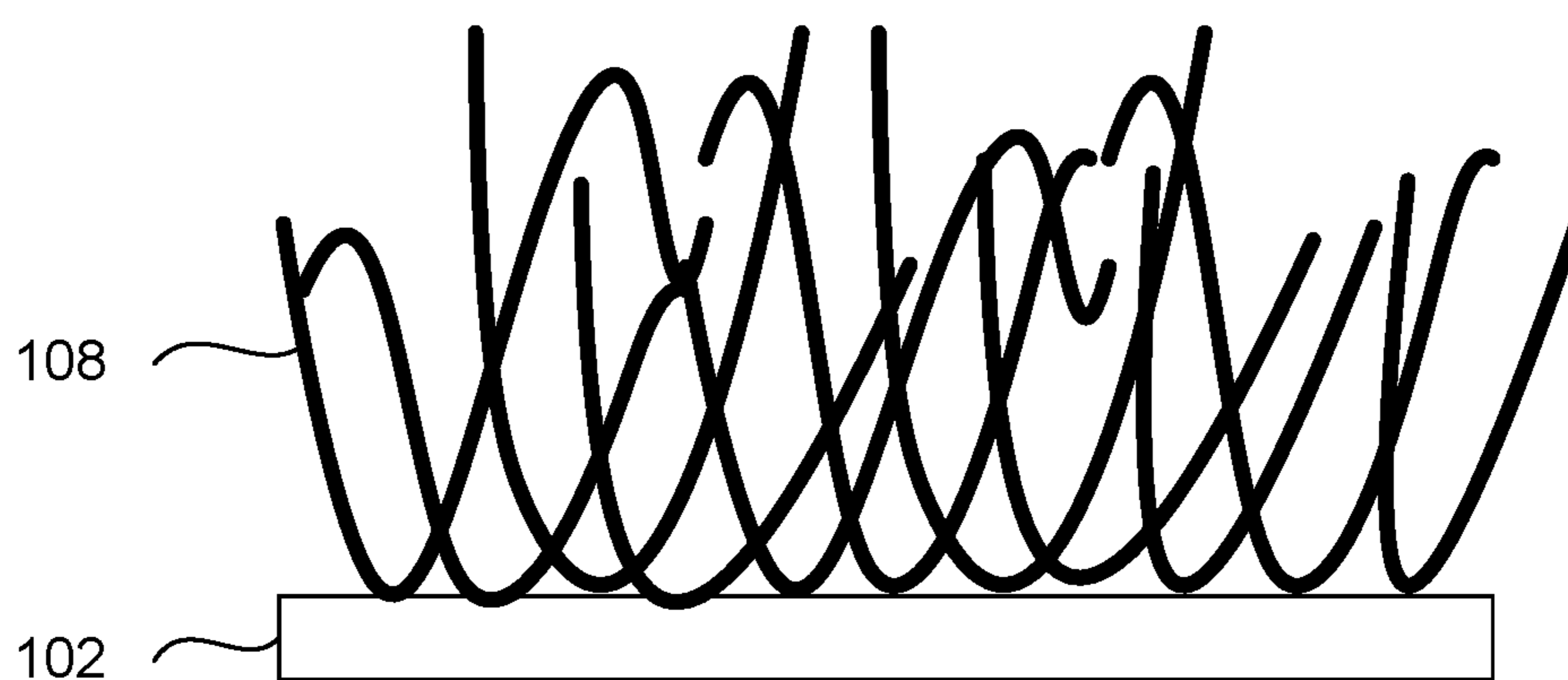




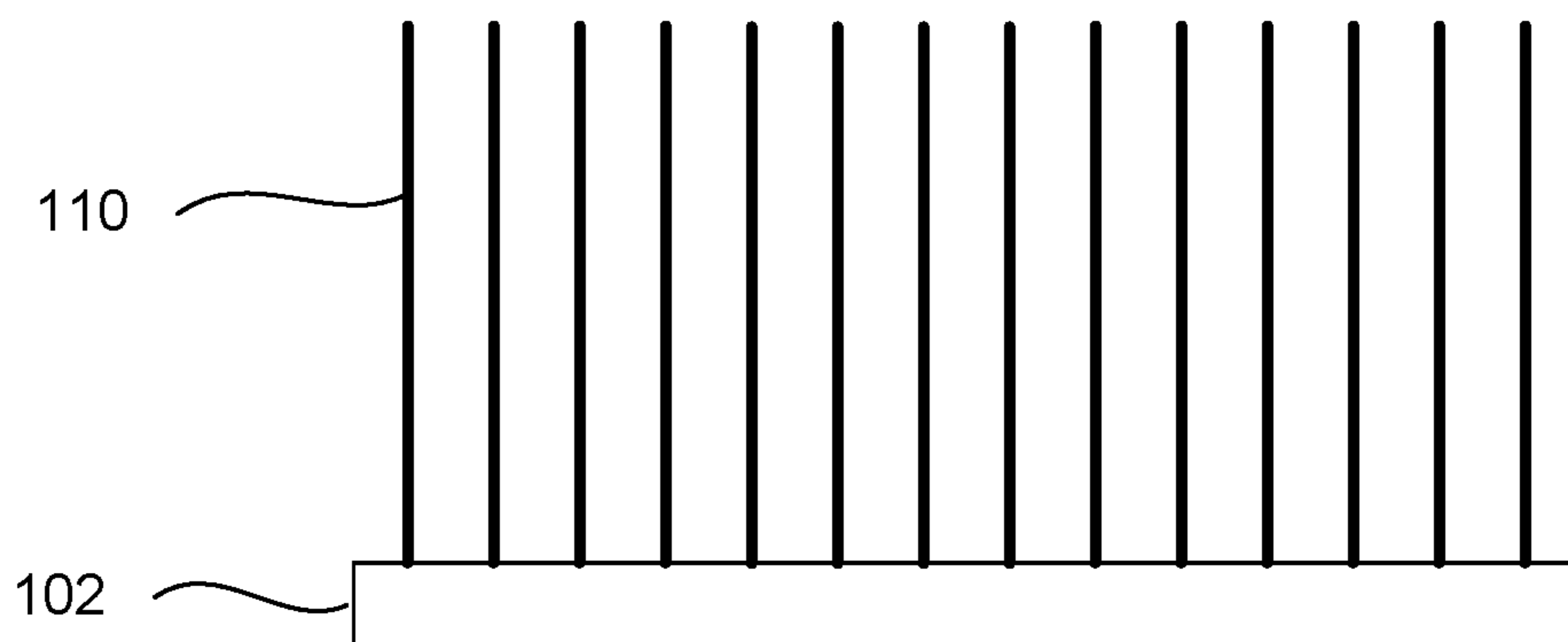
**FIG. 1A**



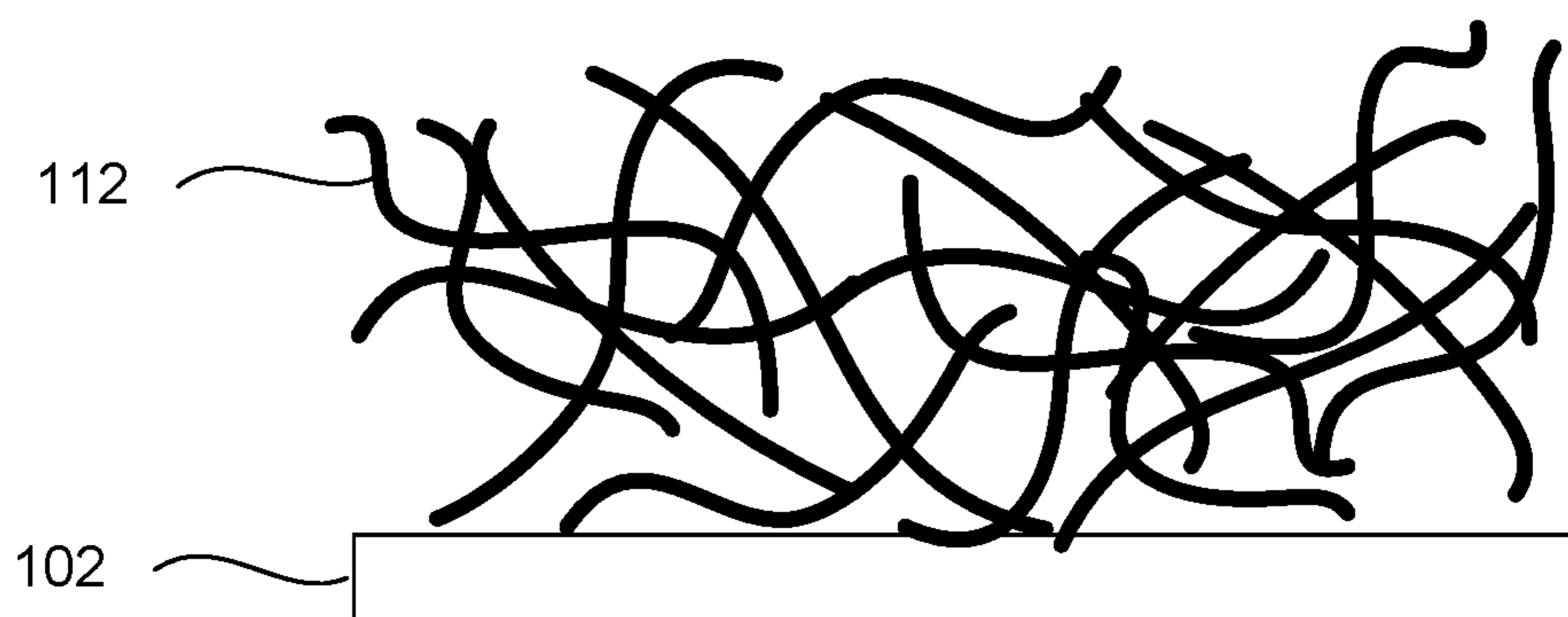
**FIG. 1B**



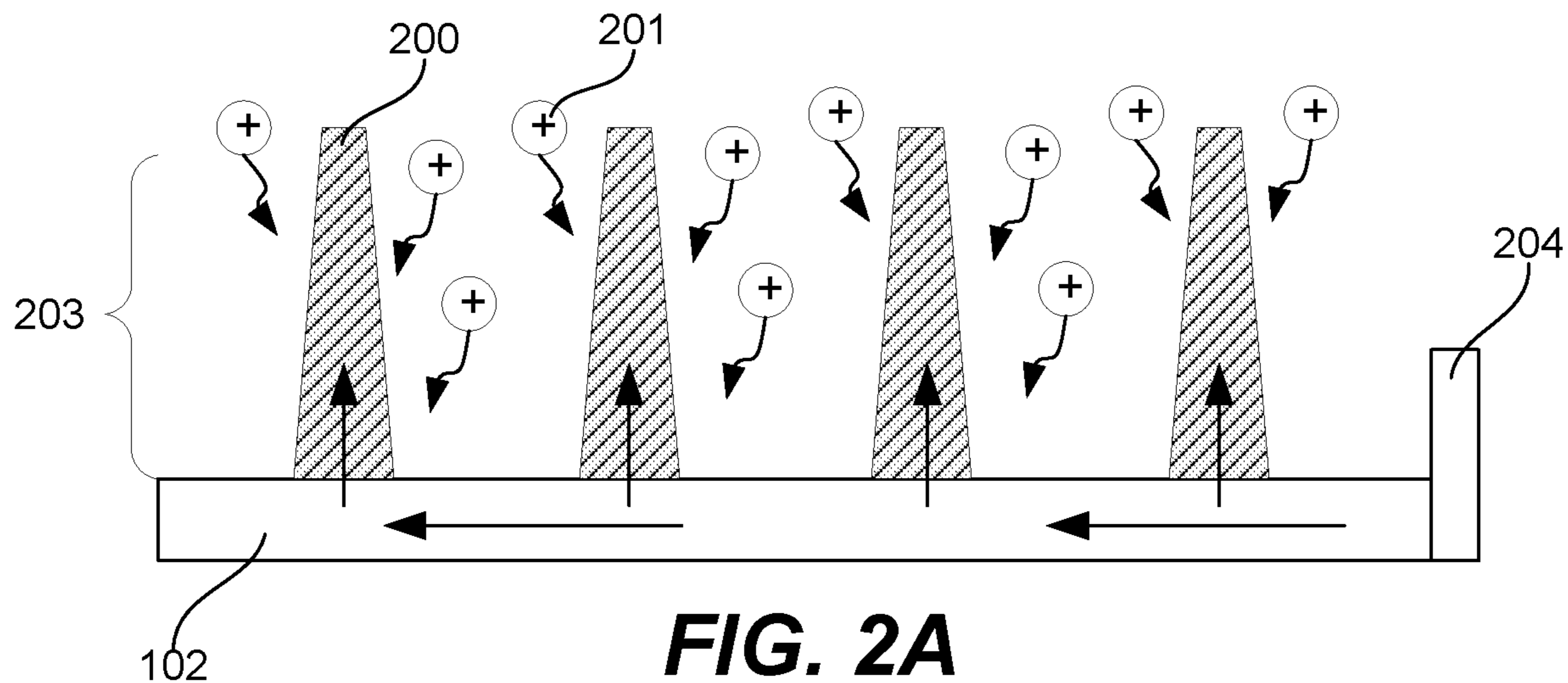
**FIG. 1C**



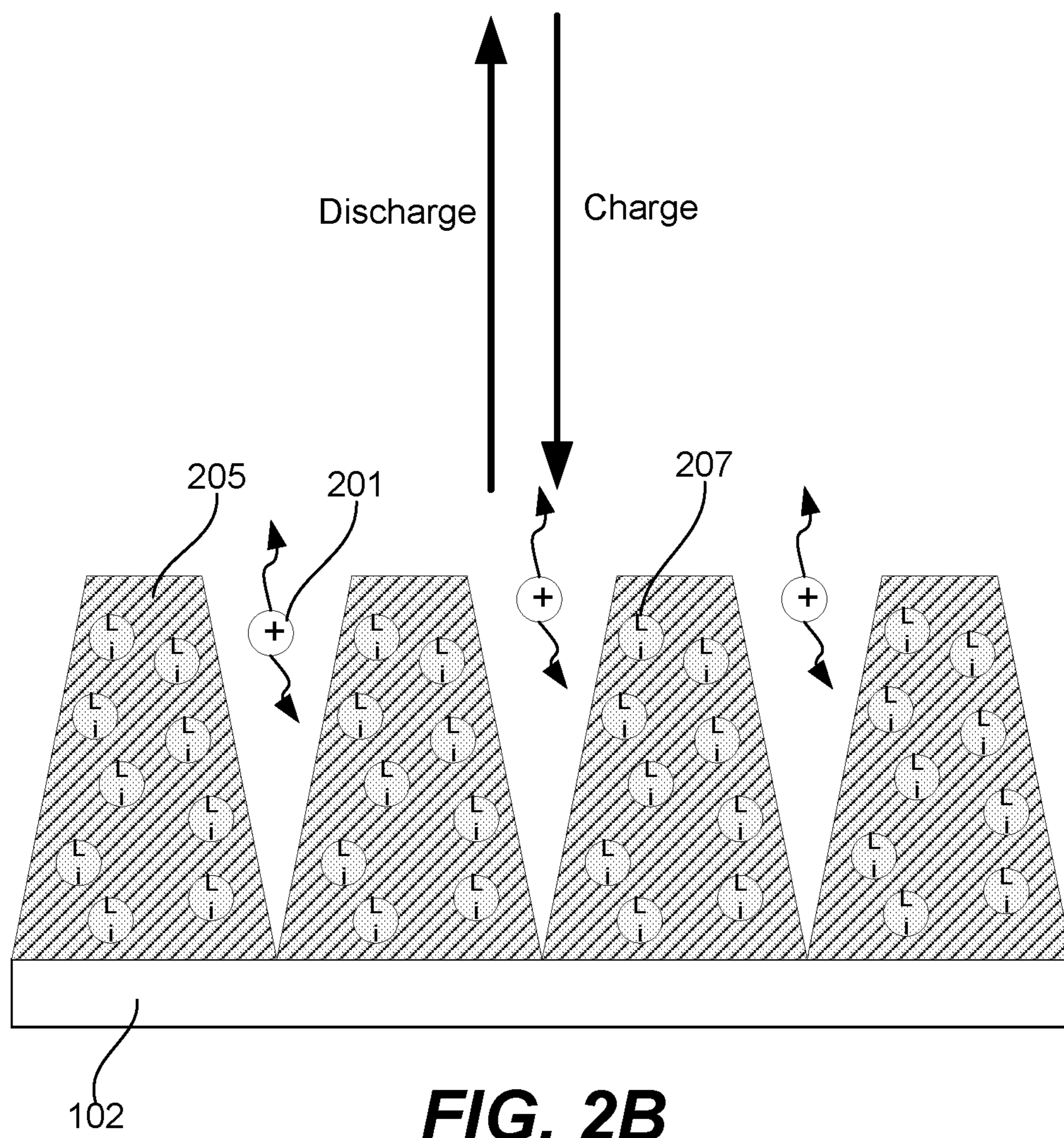
**FIG. 1D**



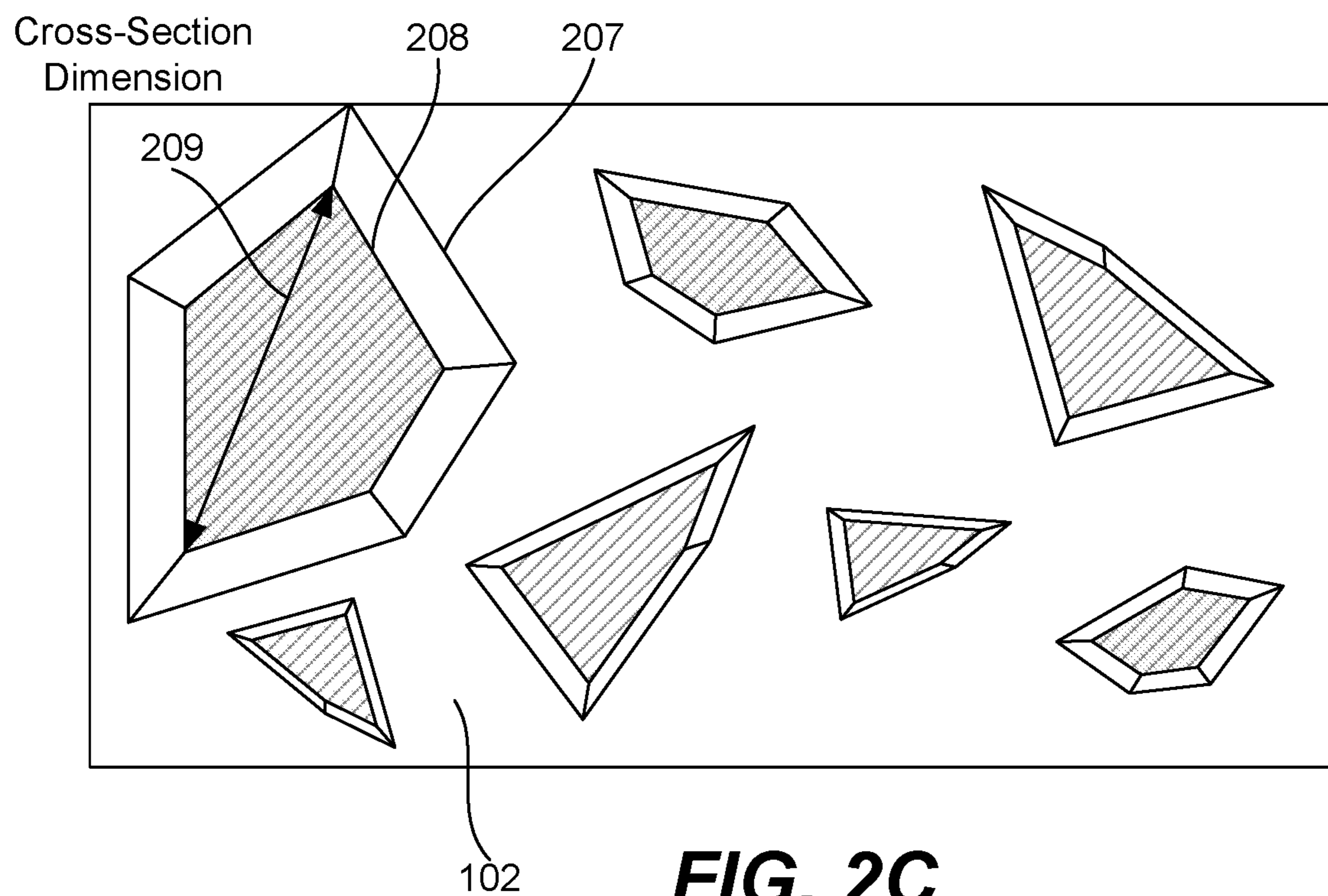
**FIG. 1E**



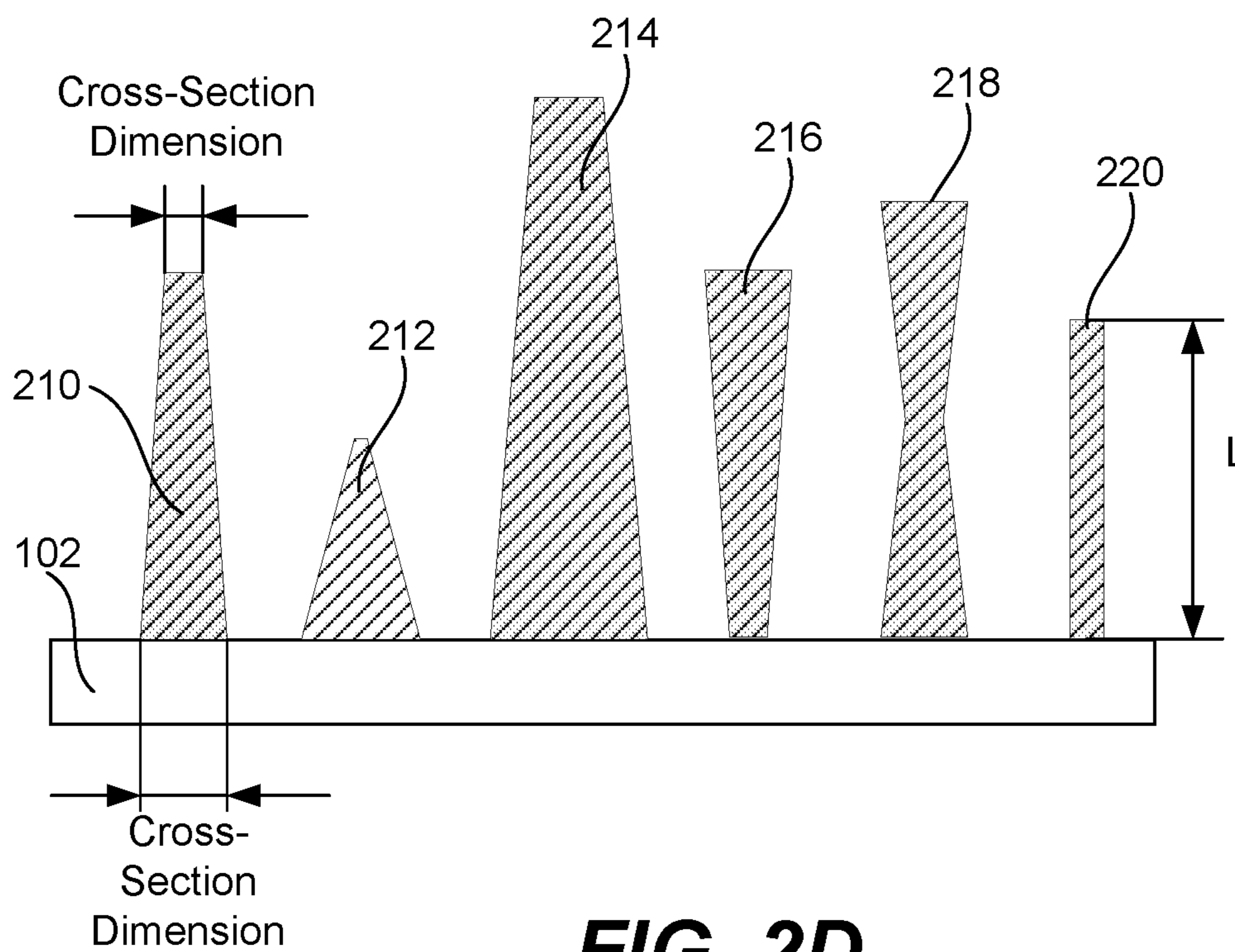
**FIG. 2A**



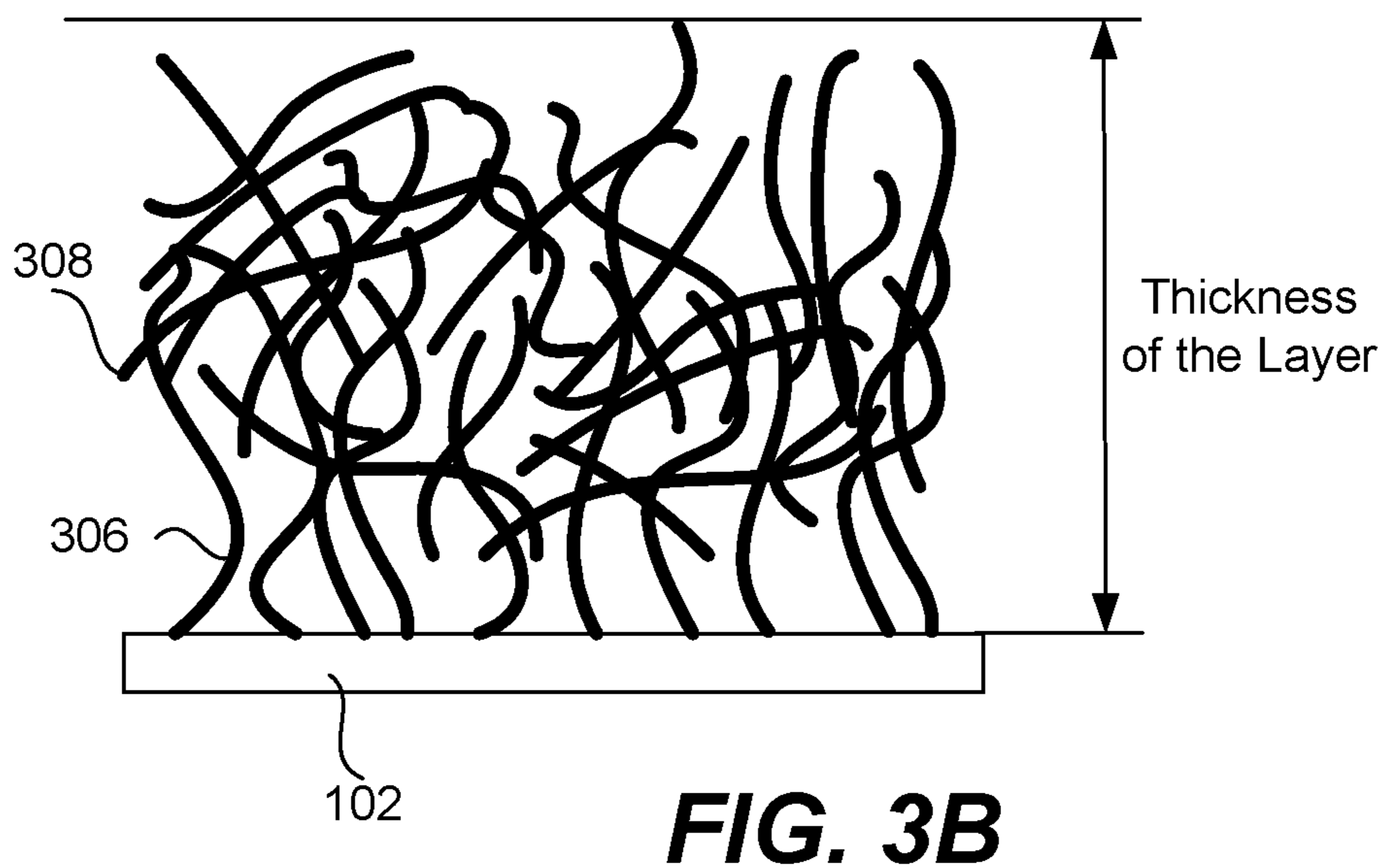
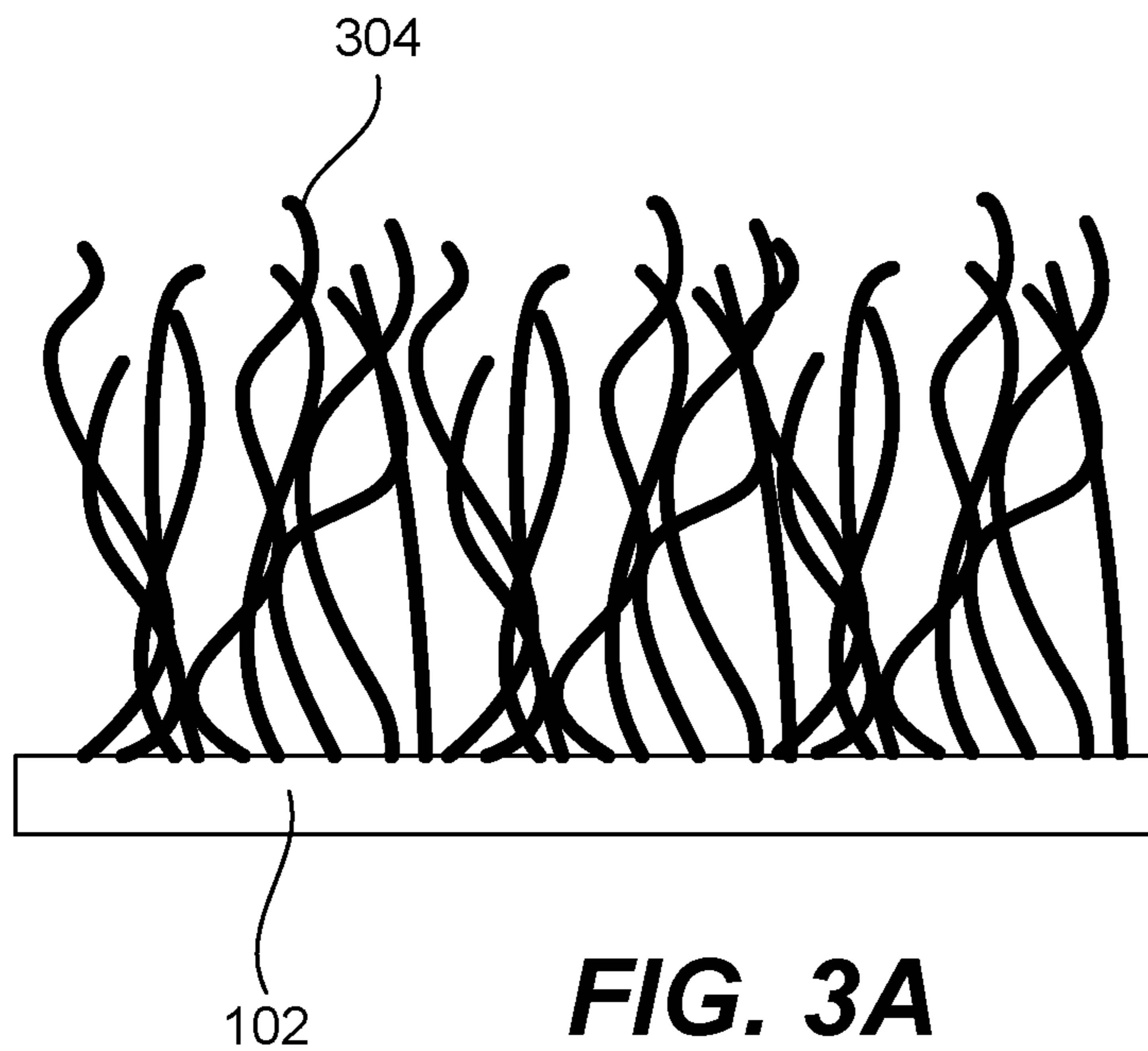
**FIG. 2B**

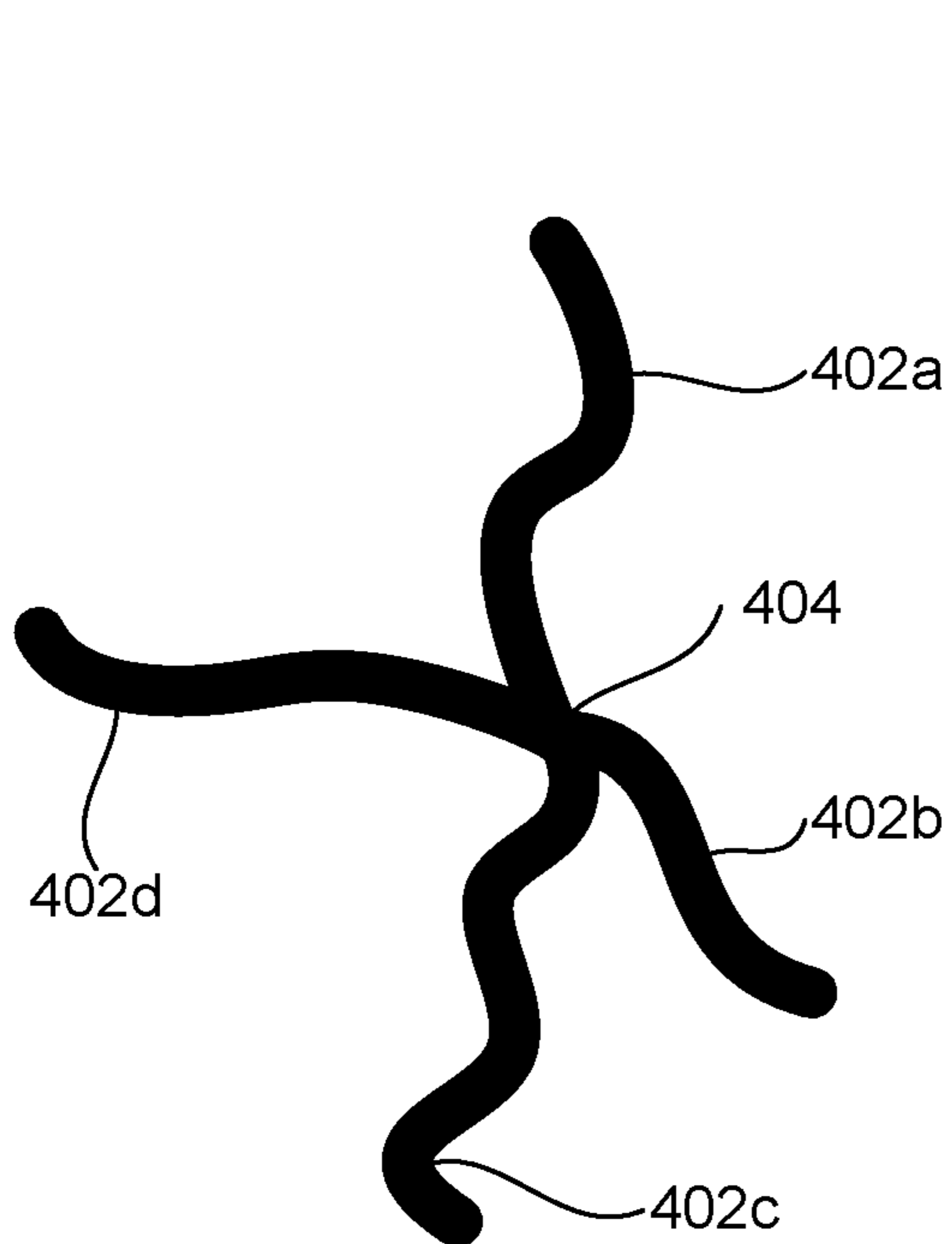


**FIG. 2C**

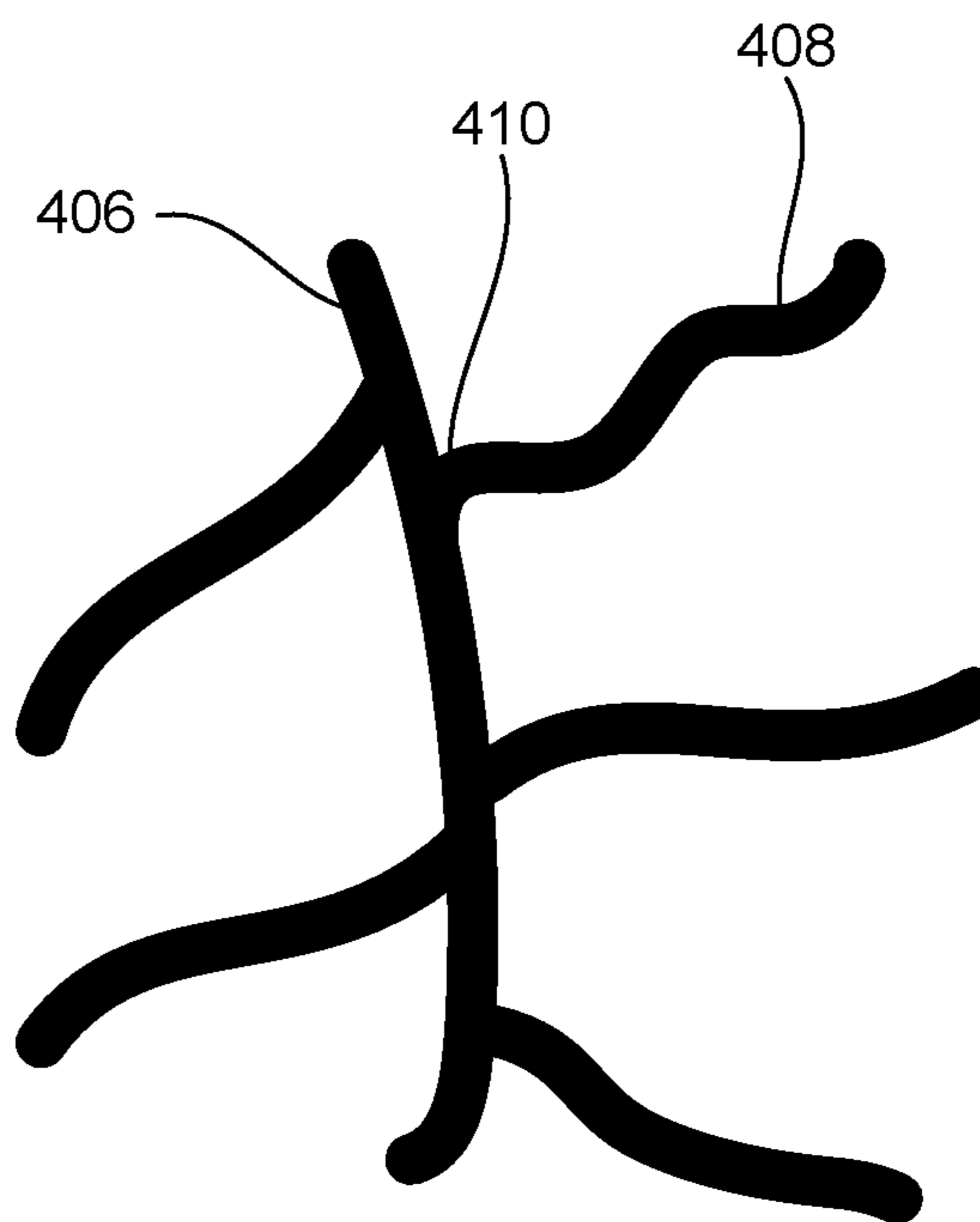


**FIG. 2D**

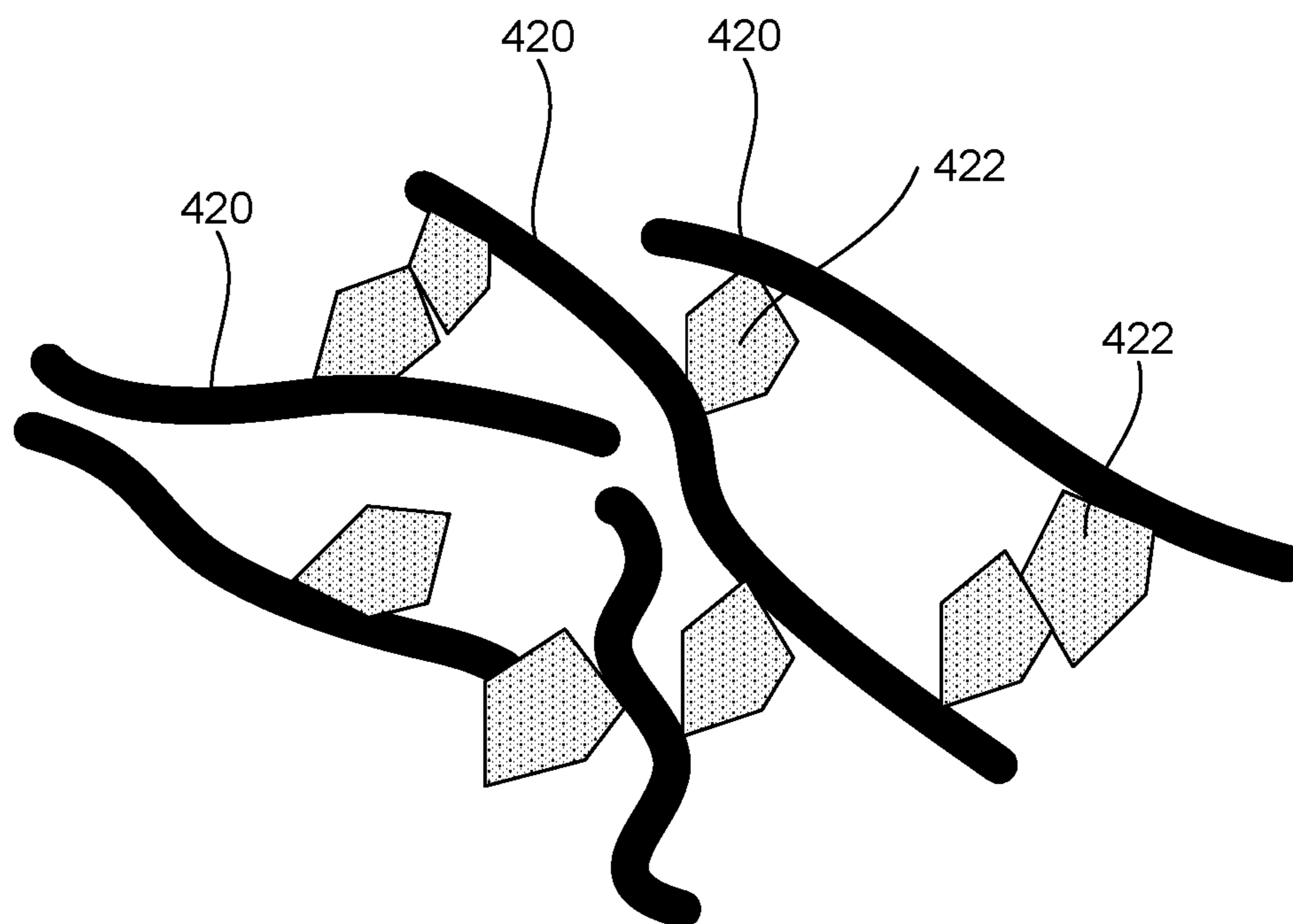




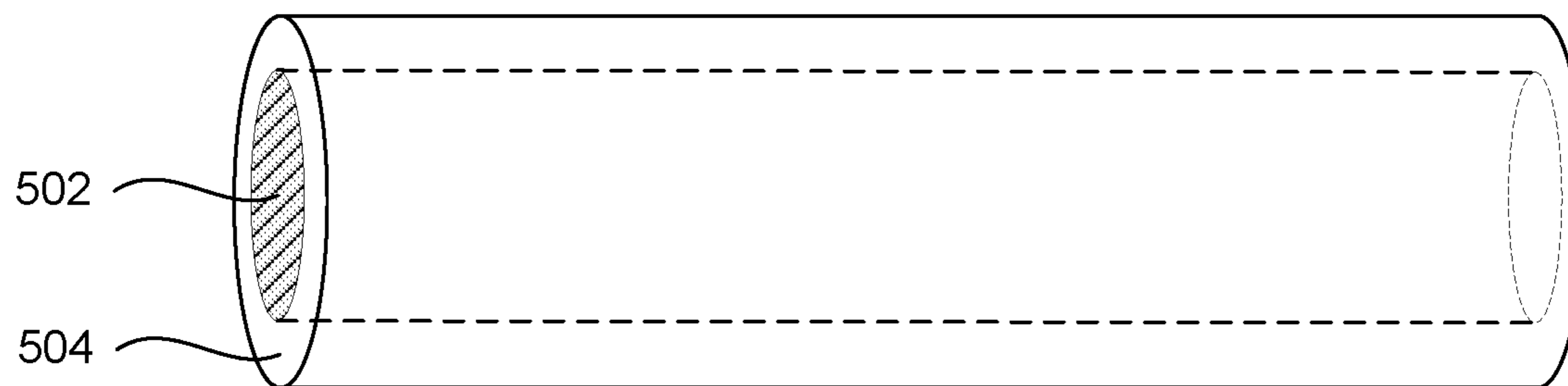
**FIG. 4A**



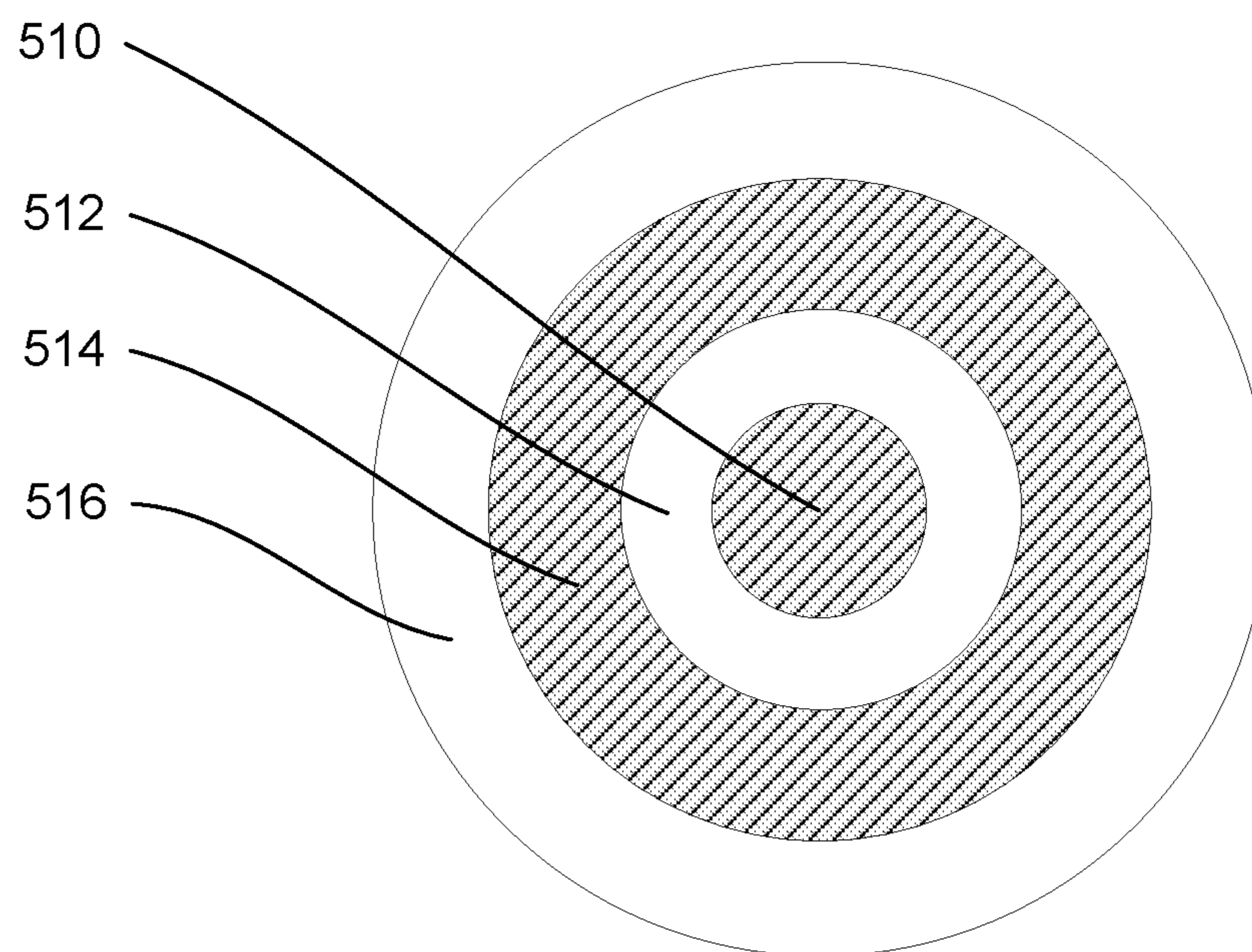
**FIG. 4B**



**FIG. 4C**

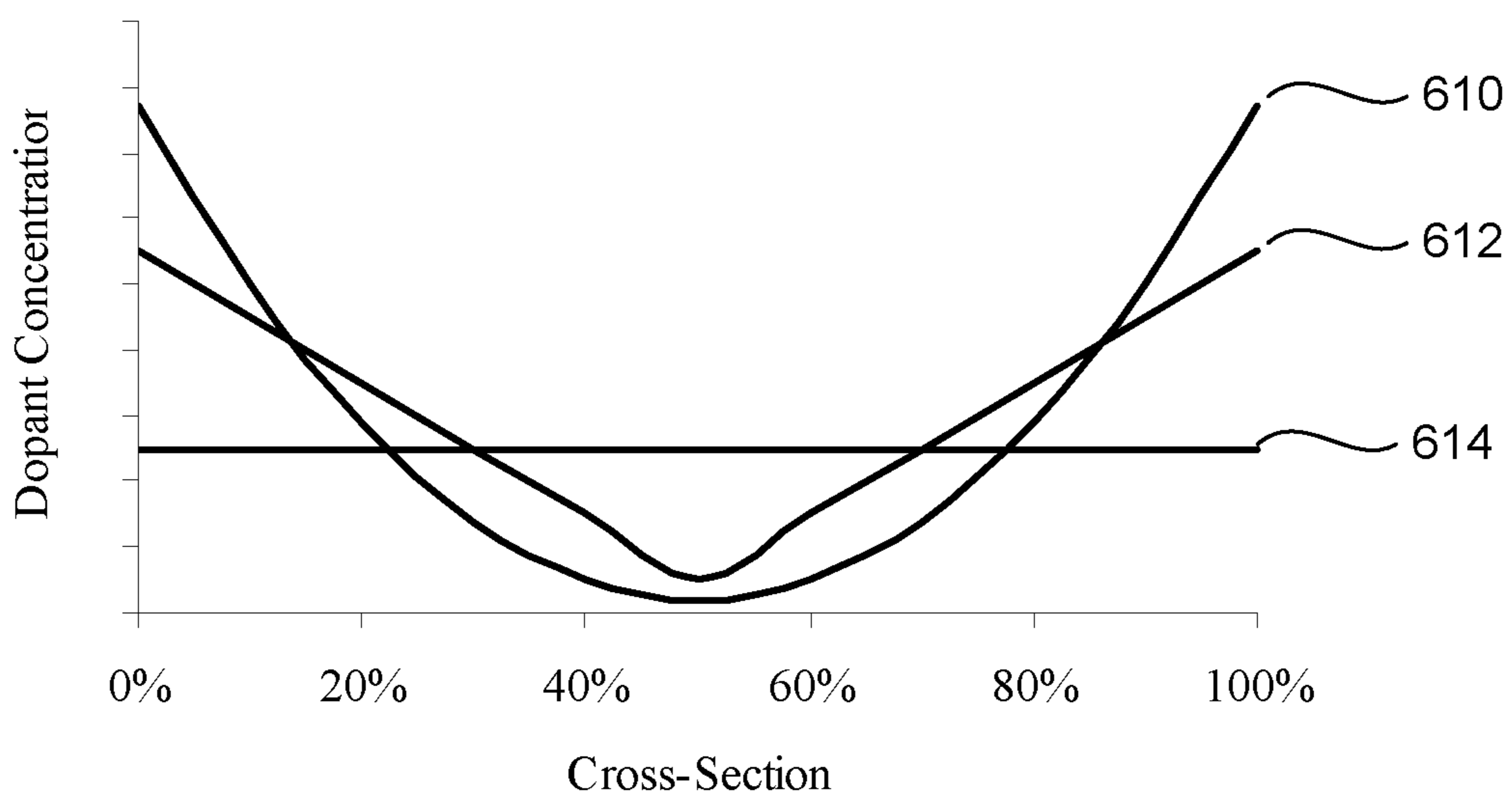


**FIG. 5A**

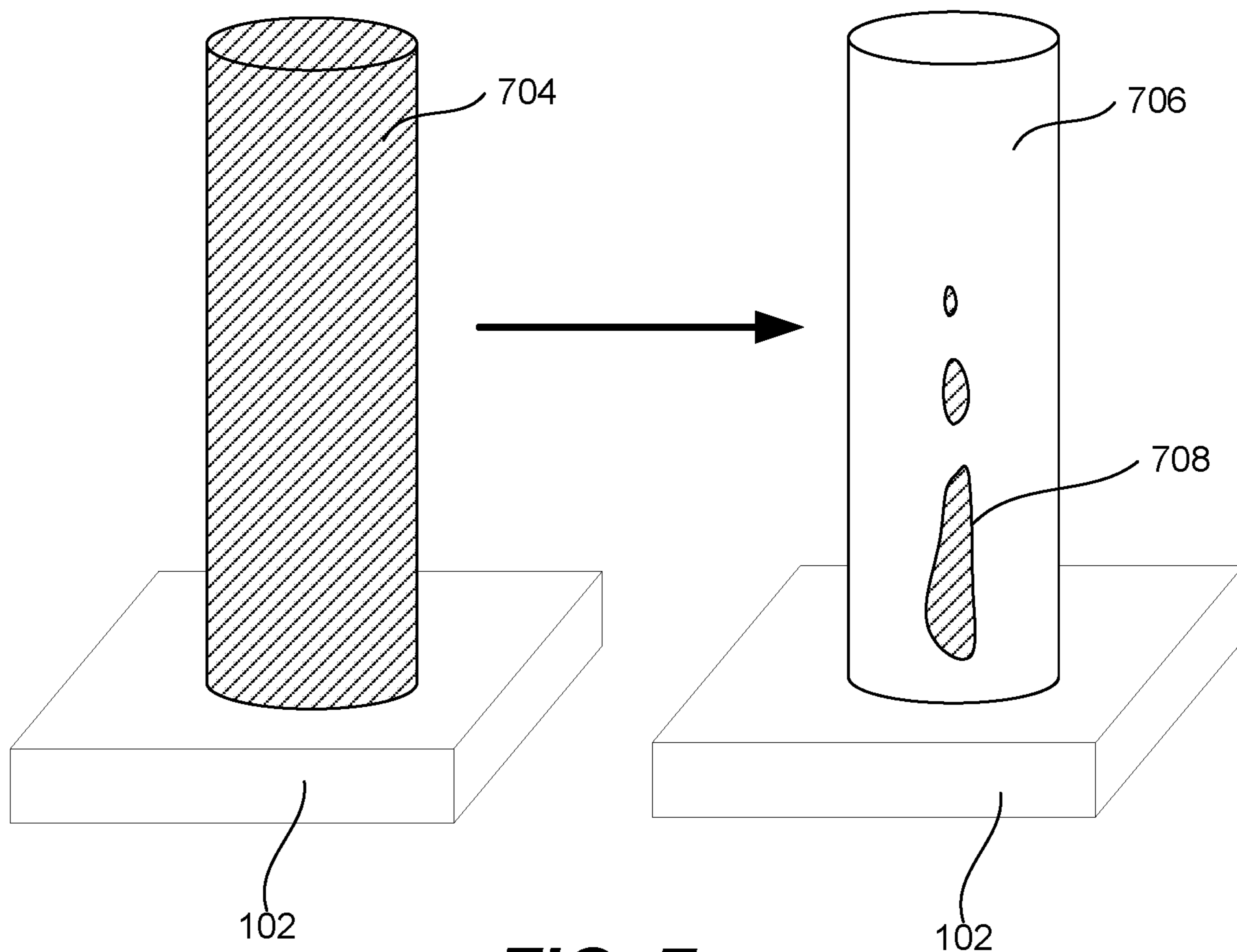


**FIG. 5B**

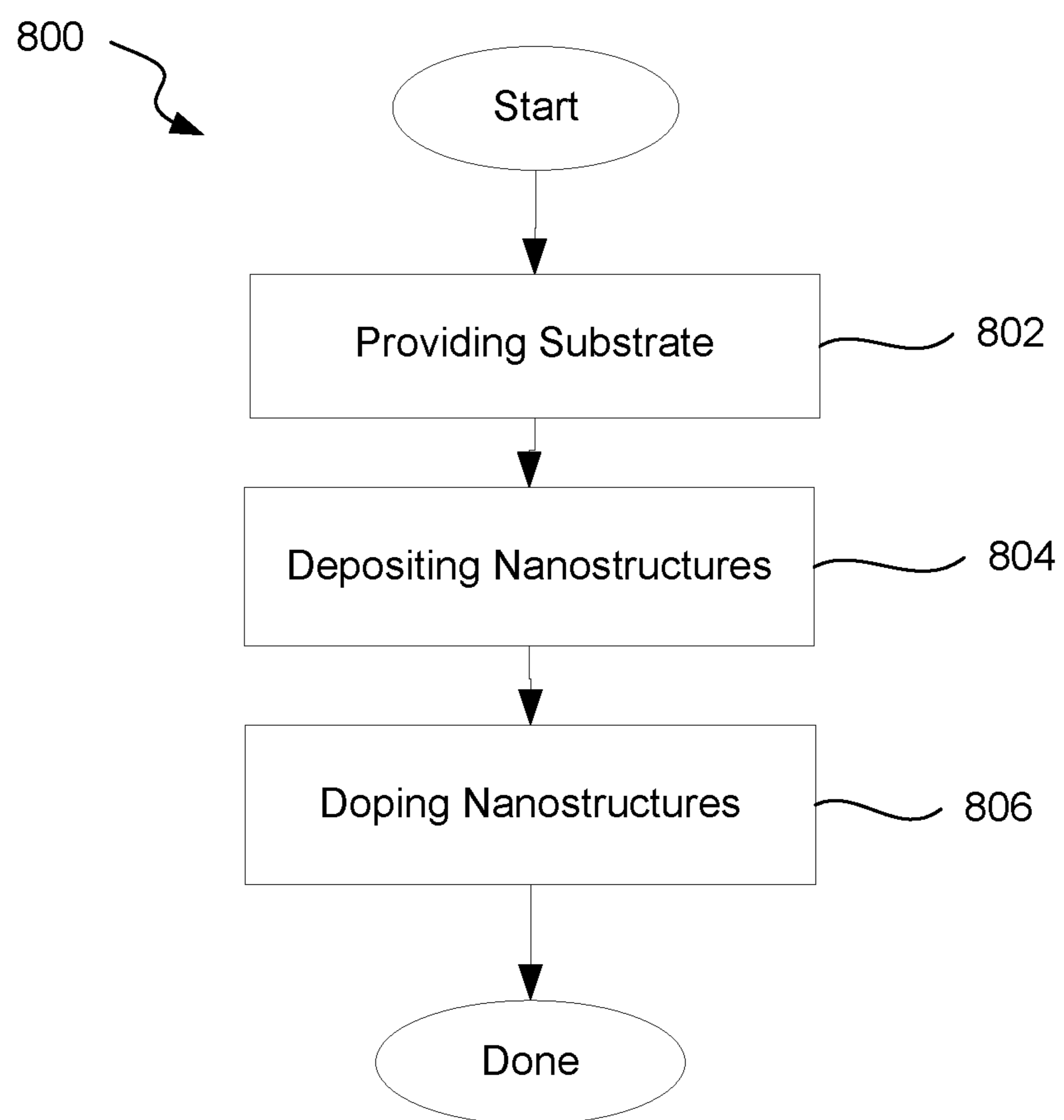




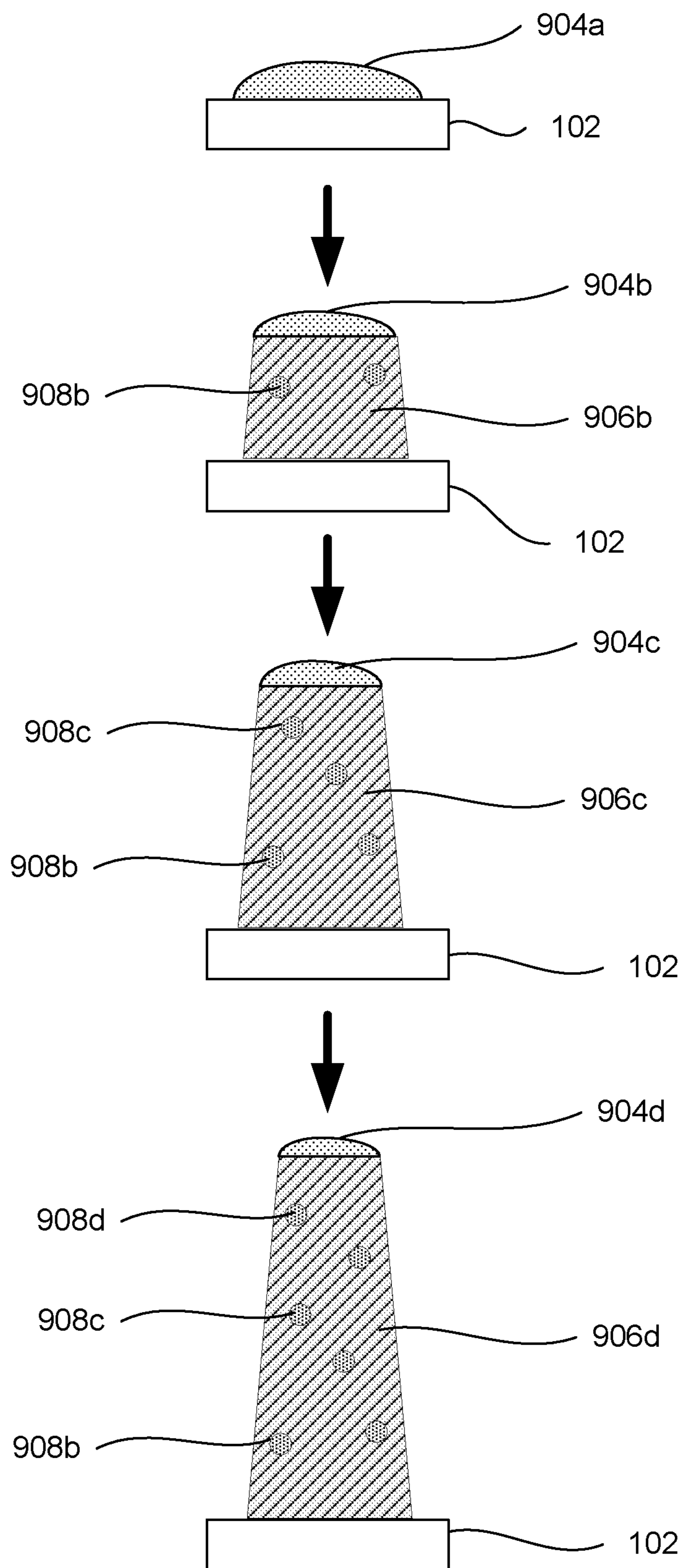
**FIG. 6**



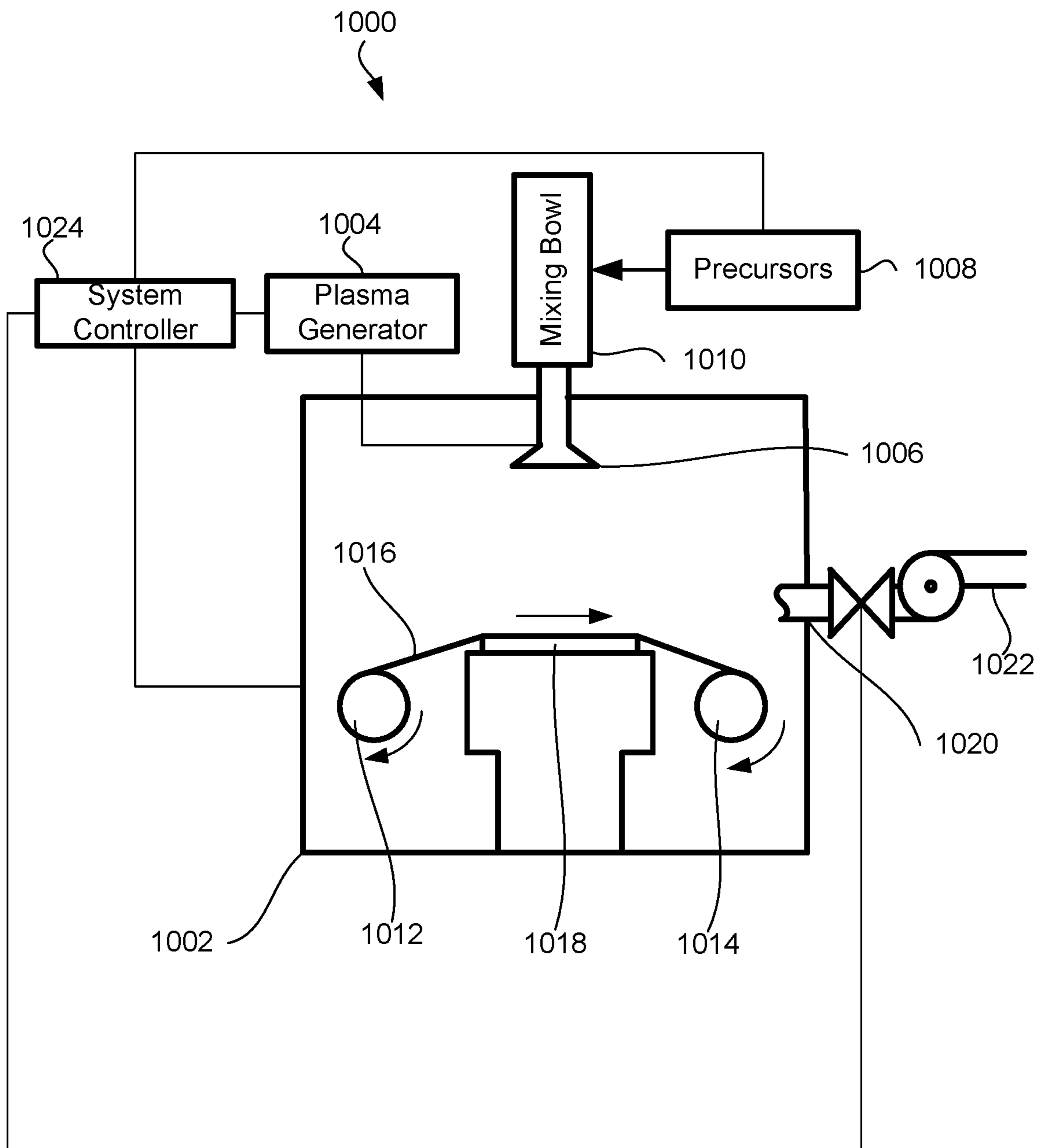
**FIG. 7**



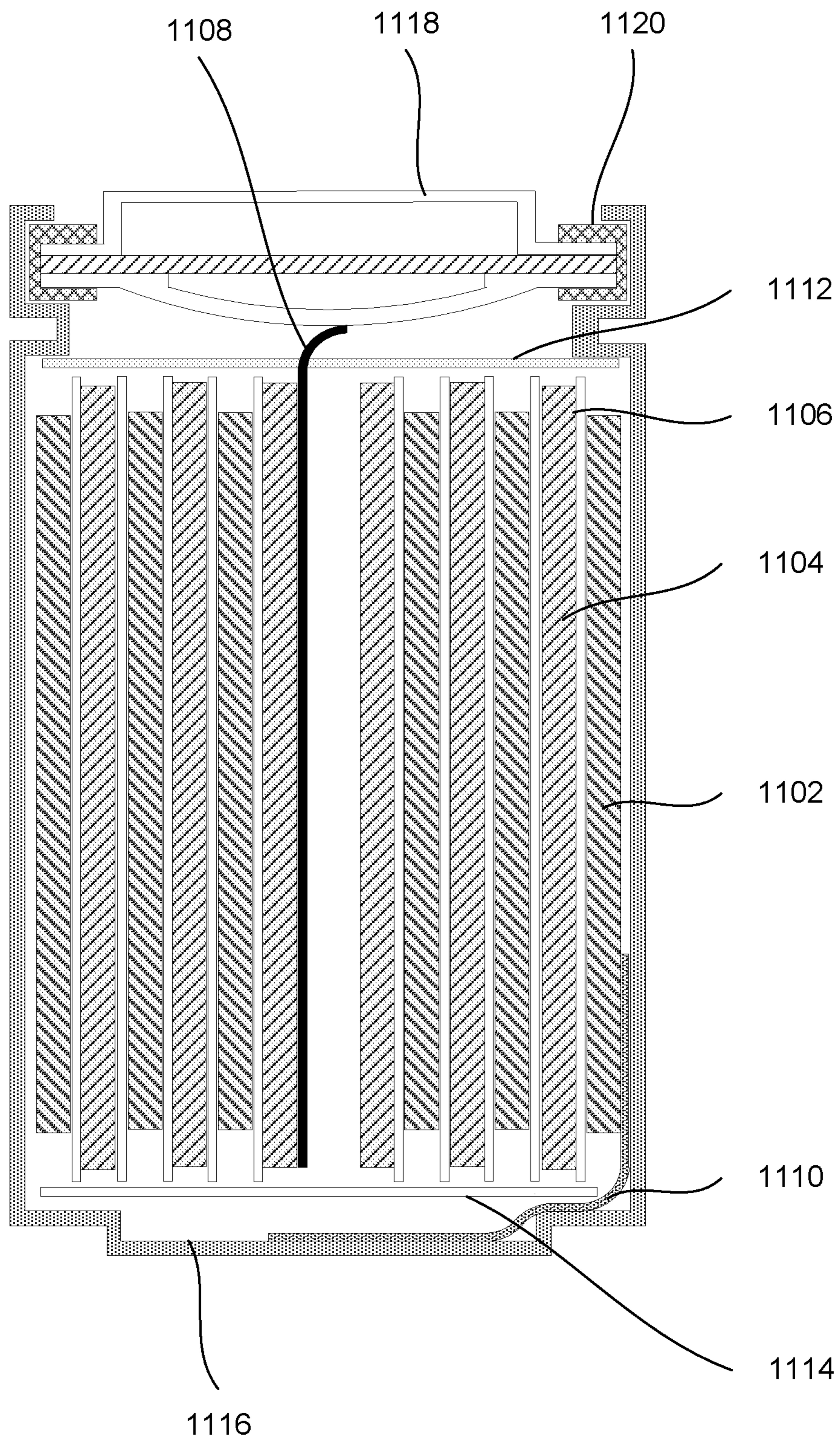
**FIG. 8**



**FIG. 9**



**FIG. 10**



**FIG. 11**

**ELECTRODE INCLUDING  
NANOSTRUCTURES FOR RECHARGEABLE  
CELLS**

INCORPORATION BY REFERENCE

[0001] An Application Data Sheet is filed concurrently with this specification as part of the present application. Each application that the present application claims benefit of or priority to as identified in the concurrently filed Application Data Sheet is incorporated by reference herein in its entirety and for all purposes.

FIELD OF THE INVENTION

[0002] The present invention relates generally to electrochemical cell components and methods of preparing such components and, more specifically, to battery electrodes containing nanowires configured to interact with electrochemically active ions and methods of preparing such electrodes and batteries including such electrodes.

BACKGROUND OF THE INVENTION

[0003] The demand for high capacity rechargeable batteries is extensive. Many applications, such as aerospace, medical devices, portable electronics, automotive and many others, demand high gravimetric and or volumetric capacity batteries. Development of the lithium ion technology has provided some advances in this area, but higher capacities are still very desirable. Lithium ion cells generally use anodes containing graphite powder that has theoretical capacity of only about 372 mAh/g.

[0004] Silicon is an attractive insertion material for lithium and other electrochemically active ions. A theoretical capacity of silicon in lithium ion cell has been estimated at about 4200 mAh/g. Yet use of silicon and many other high capacity materials for battery applications has been constrained by substantial changes in volume (swelling) of these materials during insertion of active ions. For example, silicon swells as much as 400% during lithiation. Volume changes of this magnitude cause substantial stresses in silicon structures in the negative electrodes resulting in pulverization of the structures, loss of electrical connections within the electrode, and capacity fading of the battery. Further, many high capacity materials, such as silicon, have poor electrical conductivity, and often require special design features or conductive additives that may negatively impact battery capacity. Overall, there is a need for improved application of high capacity active materials in battery electrodes that minimize the drawbacks described above.

Overview

[0005] The present invention provides new high capacity materials, such as certain silicon structures, in battery electrodes. For example, substrate-rooted silicon nanowires have shown substantial increase in battery performance including ability to maintain discharge capacity of 1000 mAh/g over 180 cycles. Shaping active materials as nanowires opens doors to many new high capacity active materials that have had limited applications because of extensive swelling, poor electrical conductivity, and other characteristics. Nanowires may be shaped and dimensioned in such a way that internal stresses are kept below their fracture limit during swelling, while high conductivity is maintained due to the nanowire length and substrate-rooted attachment. The

conductivity of the nanowires may be further increased by incorporating other materials into the nanowire structure in various forms, e.g., doping, alloying, core-shell configurations of conductive materials, and other approaches. Further, various types of substrates and substrate treatments may be used to accommodate swelling of nanowires and their enhance electrical connections with one another and the substrate.

[0006] In certain embodiments, a lithium ion battery electrode includes a conductive substrate and silicon containing nanowires growth-rooted to the conductive substrate. The nanowires include a conductivity enhancement component for reducing electrical resistance of the nanowires. The nanowires are configured for inserting and removing lithium ions during battery cycling. The capacity of at least about 1500 mAh/g is maintained after 20 cycles. In this or other embodiments, the capacity of silicon containing nanowires is at least about 600 mAh/g after 100 cycles.

[0007] In certain embodiments, the nanowires include a core and a shell. The material of the core is different from the material of the shell. The core includes a conductivity enhancement component, such as a carbon containing material, a silicide, or a carbide. In some embodiments, the nanowires include a core and two or more shells. The material of the core is different from the material of the innermost shell. Further, materials of any two adjacent shells are different.

[0008] The nanowires may be doped with one or more dopants. Dopants serve as conductivity enhancement components. In certain embodiments, a dopant includes one or more group III and V elements of the periodic table. A dopant may have a varying concentration throughout the nanowires. For example, the concentration may be higher near the outer surfaces of the nanowires than near the centers.

[0009] Nanowires are generally elongated structures. In certain embodiments, nanowires have an average aspect ratio of at least about 100 in a fully discharged state. An average cross-section dimension of the nanowires may be between about 1 nanometer and 300 nanometers in a fully discharged state. In certain embodiments, an average cross-section dimension of the nanowires is such that a fracture limit caused by swelling is not reached at the maximum charge level.

[0010] The nanowires may have an average length of at least about 100 micrometers in a fully discharged state. Nanowires may form a layer that is a part of the lithium ion battery electrode. Such layer may have porosity of less than about 75 percent. In the same or other embodiments, the layer has an average thickness greater than at least the average length of the nanowires.

[0011] In certain embodiments, the nanowires include materials, such as germanium, tin, tin oxide, or titanium oxide. The conductive substrate may include stainless steel, copper, or titanium.

[0012] Electrodes containing nanowires may be used in a lithium ion battery. In certain embodiments, the battery includes a negative electrode with a conductive substrate and silicon containing nanowires growth-rooted to the conductive substrate, a positive electrode, and a lithium ion transporting medium positioned between the negative electrode and the positive electrode. The negative electrode may be configured for inserting and removing lithium ions during battery cycling while maintaining capacity of at least about

1500 mAh/g after 20 cycles. The nanowires may include a conductivity enhancement component for reducing electrical resistance of the nanowires.

[0013] Also provided is a method of manufacturing an electrode for use in a lithium ion battery. In certain embodiments, the method includes providing a conductive substrate and forming silicon containing nanowires growth-rooted to the conductive substrate. The nanowires are configured for inserting and removing lithium ions during battery cycling while maintaining capacity of at least about 600 mAh/g after at least 100 cycles. The nanowires may be first formed without a conductivity enhancement component and then treated to introduce the conductivity enhancement component into the nanowires. In certain embodiments, the conductivity enhancement component includes boron, aluminum, or gallium. The conductive substrate may be copper, stainless steel, or titanium.

#### BRIEF DESCRIPTION OF THE DRAWINGS

[0014] FIGS. 1A-1E illustrate examples of substrate rooted and non-rooted nanostructures in accordance with different embodiments.

[0015] FIGS. 2A-2B illustrate an anode example that includes nanostructures in contact with a substrate in discharge and charge states during initial cycling.

[0016] FIG. 2C illustrates a top schematic view of an electrode example showing cross-sectional profiles of nanostructures.

[0017] FIG. 2D illustrates a side view of nanostructure examples showing different side profiles and dimensions.

[0018] FIG. 3A illustrates an active layer example with growth-rooted nanostructures having wire-like shapes.

[0019] FIG. 3B illustrates an active layer example with partially growth-rooted nanostructures having wire-like shapes.

[0020] FIGS. 4A-4C illustrate different examples of nanostructure interconnections.

[0021] FIGS. 5A-5B illustrate core-shell examples of nanostructures in accordance with certain embodiments.

[0022] FIG. 6 is an example plot of different illustrative dopant concentration profiles.

[0023] FIG. 7 illustrates transition from a crystalline to an amorphous structure in a nanostructure.

[0024] FIG. 8 illustrates an example of a method depositing growth-rooted nanostructures on a substrate.

[0025] FIG. 9 illustrates an example nanostructure during different stages of the deposition process.

[0026] FIG. 10 illustrates a CVD apparatus example for depositing nanostructures.

[0027] FIG. 11 illustrates a wound cell example with one or more electrodes containing nanostructures.

#### DETAILED DESCRIPTION OF EXAMPLE EMBODIMENTS

[0028] In the following description, numerous specific details are set forth in order to provide a thorough understanding of the present invention. The present invention may be practiced without some or all of these specific details. In other instances, well known process operations have not been described in detail to avoid obscuring the present invention. While the invention will be described in conjunc-

tion with the specific embodiments, it will be understood that it is not intended to limit the invention to the embodiments.

#### Introduction

[0029] In rechargeable electrochemical cells, charge carrying ions (i.e., electrochemically active ions or, simply, active ions) are transferred between two electrodes. In one half-cycle, these ions are removed from one electrode and inserted into another electrode. Cell performance depends on how many ions can be inserted and removed for a given size and weight of the electrode, how fast the insertion and removal process can be performed, and how many cycles the electrodes can go through without substantially losing their initial properties, among other characteristics. Electrodes include one or more components, such as active materials, additives, and substrates, that are responsible for achieving and maintaining these properties.

[0030] For the purposes of this application, an “active material” is defined as an electrode’s component that provides ion insertion sites. Each electrode in an electrochemical cell has at least one corresponding active material. In traditional lithium ion cells, a cathode active material is generally lithium cobalt oxide powder, lithium iron phosphate, etc., while an anode active material is generally graphite powder. In certain embodiments of the present invention, active materials are formed into nanostructures, such as nanowires and include one or more of the following components: silicon, germanium, tin, tin oxide, and titanium oxide.

[0031] An “active layer” is an electrode layer that contains an active material and, generally, does not include a substrate. However, in some cases, the boundary between the active layer and the substrate is not sharp or abrupt. This may be the case, for example, where the substrate is or includes a mesh or foam. In certain embodiments, a conductive substrate may abut one or two active layers of the electrode. For example, an active material may be deposited as nanowires onto a metallic foil forming an active layer in the contact with the metallic foil. In other embodiments, an active layer may intertwine with a substrate, such as mesh substrate or a substrate that is reconfigured after nanowires deposition. An active layer may also contain other components that are not active materials, such as conductive additives and binders, collectively referred to as “additives.”

[0032] The term “substrate-rooted” is used herein to describe structures illustrated in FIGS. 1A-1D having nanostructures, such as nanowires, (104, 106, 108, and 110) that are physically and conductively attached to a substrate 102, which may serve as a current collector for an electrode. The nanostructures 104 may be rooted to the substrate 102 at random locations on the structure’s profiles (randomly rooted), as shown in FIG. 1A, or rooted preferentially at some particular location on the nanostructures (non-randomly rooted). Examples of non-randomly rooted nanostructures include terminally rooted nanostructures (106 and 110), shown in FIGS. 1A and 1D, and medially rooted nanostructures 108 shown in FIG. 1C. Terminally rooted nanostructures (106 and 110) are preferentially affixed to the substrate 102 at a terminal or distal end of the structures. This assumes that the nanostructures have (in general) some principal dimension that is longer than other dimensions of the structures. As explained below, many different nanostructures are contemplated, many of which will have ter-



minuses or ends (and therefore be capable of terminal rooting). Prominent examples include nanowires and nanorods, which may have aspect ratios greater than one, or more specifically, greater than four.

[0033] Medially rooted nanostructures **108** are preferentially affixed to the substrate **102** at medial position (rather than a terminal position) on the nanostructures' profiles as shown in FIG. 1C. Non-randomly rooted nanostructures need not have all the nanostructures or even nearly all of the nanostructures affixed to the substrate at the same relative location (e.g., a terminus or a particular medial position). However, they will on average have a higher fraction of the nanostructures rooted to the substrate at this particular location than would be accomplished if the nanostructures were attached to the substrate in a purely random fashion. On the other hand, non-rooted nanostructures **112** will on average have a higher fraction of the nanostructures that are not rooted to the substrate as shown in FIG. 1E. For example, nanostructures may be mixed with a binder to form slurry that is coated to the substrate. Most typically, a higher fraction of the nanostructure will not be in direct contact with or rooted to the substrate.

[0034] The unconnected or free ends of non-randomly rooted nanostructures may be aligned in a common direction (e.g., aligned nanostructures **110** shown in FIG. 1D) or may be randomly aligned (e.g., random terminally rooted nanostructures **106** shown in FIG. 1B). For example, aligned terminally rooted nanowires **110** may be aligned in a common direction with respect to the substrate **102**, such as orthogonally to the substrate surface at the point of attachment as shown in FIG. 1D. Alternatively, the aligned terminally rooted nanowires may be aligned generally at an angle of 30 degrees from the normal, 45 degrees from the normal, and other angles (not shown). Many other non-random orientations are possible; e.g., curved or zig-zagged.

[0035] The substrate **102**, as explained more fully below, may be any appropriate shape. However, it will often be desirable to employ relatively flat or planar substrates that can serve as or easily attach to a current collector substrate used in a battery or fuel cell electrode. In alternative embodiments, substantially non-planar substrates, such as spheres, cones, arcs, saddles, and the like, may be employed. Typically, the application and/or method of fabrication will dictate the shape of the electrode.

[0036] Frequently the substrate will be of macroscopic dimensions, such that many nanostructures attach to a single common substrate surface. While the substrate may be continuous as in the case of a foil or plate, other substrate morphologies will be appropriate in some situations. Such alternative substrates include mesh substrates, perforated sheet substrates, foam substrates, felt substrates, and the like.

[0037] Typically, though not necessarily, the substrate will be conductive, having a conductivity of at least about  $10^3$  S/m, or more specifically at least about  $10^6$  S/m or even at least about  $10^7$  S/m. This may be desirable when the substrate rooted structure is employed as a fully fabricated electrode for a battery or fuel cell. As explained below, examples of suitable substrate materials include copper, titanium, aluminum, stainless steel, doped silicon, and other materials.

[0038] As mentioned, substrate rooted nanostructures (**104**, **106**, **108**, and **110**) are conductively attached to the substrate **102**. This attachment provides a direct path for

electron and/or hole transport between the nanostructure and the substrate **102**, thereby providing a continuous high conductivity (depending on the materials comprising the nanostructure and substrate) pathway. The path will not require that an electron or hole hop from the nanostructure to the substrate at the point of contact. In general, the nanostructures will be mechanically affixed to the substrate such that they are not removed except by breaking the structure. Thus, substrate rooted nanostructures are not connected to the substrate by elastomeric binder, for example. They may be affixed by various techniques such as pressure bonding, heating or annealing, physical bombardment, growth from the substrate, etc.

[0039] It should also be noted that substrate rooted structures may be produced by various techniques. In one class of fabrication techniques, the nanostructures are formed independently and subsequently affixed to the substrate by, e.g., annealing, impact, etc. Such techniques result in attachment rooted nanostructures. Another class of fabrication techniques forms nanostructures directly on the substrate by, e.g., chemical vapor deposition, physical vapor deposition, epitaxial growth, atomic layer deposition, and the like. Such techniques result in growth rooted nanostructures. In certain embodiments, such growth rooted techniques employ a catalytic growth or deposition process in which regions of catalyst on the substrate surface selectively promote growth of nanostructures at or proximate to the regions. A third class of fabrication techniques are the etch rooted techniques. In these examples, regions of a substrate are selected etched away to yield nanostructures protruding above the remaining bulk of the un-etched substrate. Necessarily the etching process terminates prior to etching the whole way through the substrate. As a result, only some the original peripheral regions of the substrate etch away, while the bulk interior of the substrate remains.

[0040] The composition of the nanostructures may be the same or different from that of the substrate. Additionally, the composition of the individual nanostructures may be the same or different. In the case of different compositions, some nanostructures will have one composition (e.g., doped silicon) and at least some other nanostructures will have a different composition (e.g., tin, layered carbon-silicon, etc.). In certain embodiments, the substrate is a highly conductive current collector material such as copper, brass, stainless steel, etc. while the nanostructures are silicon or another material having a high capacity for lithium ion insertion.

[0041] "Active ions" are defined as ions that are used in an electrochemical cell to transferred charge between the negative electrode and the positive electrode through an electrolyte and participate in electrochemical reactions in at least one of the electrodes. While this description generally refers to lithium ions, it should be understood that any other suitable materials may be used. For example, sodium ions, magnesium ions, potassium ions, and protons may be also used in certain configurations.

[0042] Electrodes and particularly their active materials transform during insertion and removal of ions. Active materials accepting ions generally increase in size. The size increase affects porosity, thickness, and other properties of the active layer. Often some of the properties are not reversible. Therefore, properties of active layers are discussed in the context of electrodes that have not gone through any cycling, i.e., newly constructed electrodes are described. For example, in the anode context, the properties

of an anode are described before initial insertion of the active ions (i.e., the first charge) unless specifically stated otherwise.

**[0043]** A “discharge state” and a “charge state” refer to two relative charge states of an electrochemical cell that has reached either a lower or an upper cut-off voltage respectively. These cut-off voltages are generally predetermined limits at which further discharge or charge of the cell has been determined to be impractical. The cut-off voltages are usually set based on the cell design and application. For example, a typical lithium ion cells with a graphite anode and a lithium cobalt oxide cathode is cycled between 4.2V (upper cut-off voltage) and 3.0 V (lower cut-off voltage). The cell capacity is determined by the cut-off voltages and generally decreases over the battery life. Usually, the first charge capacity is higher than the first discharge capacity. The difference between the first-charge and the first-discharge capacities indicates that some amount of the active ions remain in the anode in the charged state, which is referred to as irreversible capacity. The ratio of discharge capacity to charge capacity is also referred to as Coulombic efficiency. Discharge-capacity generally decreases with a number of cycles. Further, capacity generally depends on the current that is used to charge or discharge a cell, also referred as rate of charge/discharge or, simply, rate. Increasing rates tend to decrease capacities.

**[0044]** It should be noted that while electrode’s active material provides cell’s capacity, cell’s energy density (e.g., volumetric or gravimetric capacity) may be specified with reference to many different cell components, such as active material, active layer, electrode, or. Unless otherwise specified, the capacity values presented in this document are for structures containing active materials, such as nanowires, that form an active layer. For example, gravimetric capacity value would be based on the active materials, conductivity enhancement agents that are parts of the nanostructure (e.g., dopants).

**[0045]** In certain embodiments, the gravimetric first cycle discharge capacity of the nanowires is at least about 1500 mAh/g, or more specifically at least about 2000 mAh/g, even more specifically at least about 2500 mAh/g, or at least about 3000 mAh/g, or at least about 3700 mAh/g. In the same or other embodiments, the gravimetric tenth cycle discharge capacity of the nanowires is at least about 500 mAh/g, or more specifically at least about 1000 mAh/g, even more specifically at least about 1500 mAh/g, at least about 2000 mAh/g, at least about 2500 mAh/g, or at least about 3000 mAh/g, or 3500 mAh/g. The above cell capacity values may be defined for certain cell operating regimes that may be characterized by, e.g., cut off voltages, current rates. In certain embodiments, the above cell capacities are specified for cut of voltage of about 150 mV, 100 mV, 50 mV, and 10 mV at between about 0.1 C and 0.5 C discharge rate.

#### Electrode Structure

**[0046]** Many embodiments described herein correspond to both cathodes and anodes. For clarity and concision, the references are primarily made to anodes. It will be understood that cathode designs are generally concerned with similar issues of ions insertion/removal, swelling, electric conductivity, ionic mobility, and others. Therefore, many design approaches described herein are applicable to cathodes as well.

**[0047]** FIG. 2A illustrates an anode example that includes nanostructures **200** in contact with a substrate **102**. The nanostructures **200** contain active material for insertion/removal of lithium ions **201** during charging/discharging. The nanostructures form an active layer **203** over the substrate **102**. In certain anode embodiments, insertion of active ions **201** into nanostructures transforms the discharged nanostructures **200** shown in FIG. 1A into the charged nanostructures **205** shown in FIG. 2B. Note that active ions are typically receive electrons and are converted into charged equivalents **207** of the active ions. For example, in lithium ions cells, lithium ions are converted to lithium atoms in the anode. In a similar manner, the removal of lithium ions **201** from the charged nanostructures **205** transforms them into the discharge nanostructures **200**. Changes in the size of the nanostructures presented in FIGS. 2A-2B are for illustrative purposes only. Generally, materials increase in size, i.e., swell, due to insertion of other materials into original structures whether through intercalations, alloying, chemical reactions, or any other method of insertion. Materials having high capacities, i.e., capable of accepting many ions per unit mass or volume, tend to exhibit more swelling. One of the challenges in electrode design is to allow for this swelling without substantial destruction of the electrode structure and losses of cell performance.

**[0048]** In certain embodiments, the current collection substrate **102** is a conductive material suitable for the corresponding electrode. Substrate materials for electrodes used in various lithium ion cells may include copper and/or copper dendrite coated metal oxides, stainless steel, titanium, aluminum, nickel (also used as a diffusion barrier), chromium, tungsten, metal nitrides, metal carbides, carbon, carbon fiber, graphite, graphene, carbon mesh, conductive polymers, or combinations of above including multi-layer structures. It will be understood by one having ordinary skills in the art that selection of the materials also depends on electrochemical potentials of the materials. The substrate material may be formed as a foil, films, mesh, laminate, wires, tubes, particles, multi-layer structure, or any other suitable configurations. For example, the substrate **102** may be a stainless steel foil having thickness of between about 1 micrometer and 50 micrometers. In other embodiments, the substrate **102** is a copper foil with thickness of between about 5 micrometers and 30 micrometers.

**[0049]** Certain parameters and design considerations may drive selection of materials, morphologies, structural configurations of the substrate, e.g., tensile strength, Young’s module, shear strength, surface roughness, surface activities, surface morphology, melting temperature, density, galvanic potential, passivation properties, cost, contact resistance, bonding compatibility with other metals, welding compatibility with different methods such as ultrasonic, resistance, and laser welding.

**[0050]** In some embodiments, a mesh can be used as a substrate. Meshes are generally characterized by a wire diameter, opening size, overall thickness, and weave type. For example, meshes having a wire diameter of between about 50 nm and 500  $\mu\text{m}$  and an opening size of between about 50 nm and 500  $\mu\text{m}$  may be used. Various weave types may be used, in particular ones that are expandable and can easily change configuration during battery cycling in order to minimize fluctuation of the overall electrode thickness

and, maintain pressure to the nanostructures during full discharge to ensure electrical connectivity between various components of the electrode.

[0051] Substrates may have various degrees of roughness. Rough substrates, e.g. Ra of between about 1 micrometer and 50 micrometer, may be used to randomize the directions of nanostructure's orientation and to provide overlapping between the nanostructures (e.g., nanowires) in the active layer. Additionally, substrate roughness generally provides more surface area available for attachment of nanostructures leading to a higher volumetric density of active nanostructures.

[0052] Rough surfaces may be achieved during substrate formation or during subsequent processing. For example, the surface roughness (Ra) of electroplated copper foil is generally between about 1 micrometer and 10 micrometers. Rolled copper foil has much lower roughness, generally less than 1 micrometer. Smooth surfaces may be roughened using various techniques, such as etching, blasting, polishing. In certain examples, the substrate may be patterned or textured with channel-like structures, where the nanostructures extend from the surfaces of the channels towards each other. The nanostructures may also form connections between the two opposite surfaces of the same channel.

[0053] Electrical conductivity is another driver in substrate selection. Generally, conductive substrates are used in order to reduce the overall cell impedance. However, in some embodiments, electrically non-conductive materials may be used for the substrate **102**. Such materials may be used for mechanical support and/or for insulating the active layer **203** of one electrode from another. In this instance, the electrical current flows through the active layer **203**, which should, itself have high electrical conductivity. To this end, nanostructures may be interconnected, as further discussed below. In certain specific embodiments, an electrically non-conductive substrate may also function as a separator and provide a flow of lithium ions (i.e., provide ionic conductivity) between corresponding active layers of the anode and cathode.

[0054] In the embodiments where a substrate **102** (conductive or non-conductive) is used, one or two active layers **203** are deposited onto the substrate **102**. One-sided electrodes (i.e., only one active layer and the substrate is exposed on the other side, as shown in FIG. 1A) or one-sided portions of electrodes are typically used only where a corresponding active layer of another electrode does not exist (an outer wind of a jellyroll, external electrodes of a stack, etc.). In some examples, the substrate **200** and the active layer **203** are intertwined. For example, a mesh substrate may exist within a single active layer **203**.

[0055] In other embodiments (not shown), the electrode does not include a substrate. Both the mechanical support and electrical conduction functions are carried by the active layer **203**. For example, silicon nanostructures shaped as wires may form an intertwined mesh that has suitable mechanical strength and electrical conductivity to be used without a substrate. Sometimes mechanical support may be provided by other cell elements, such as a separator, another electrode, a casing, etc.

[0056] An electrode may include one or more current collectors **204** that provide electrical connection between the electrode and a cell terminal. If an electrode uses a conductive substrate **102**, the current collector **204** is typically attached directly to the substrate **102**, for example as shown

in FIG. 1A. The collector **204** may be attached to the substrate **102** by ultrasonic welding, resistance welding, laser welding, a mechanical fastener (e.g., a crimp), a conductive adhesive, or any other suitable form of attachment. Alternatively, the collector **204** may be a part of the substrate **102**. If a conductive substrate is not used (i.e., a non-conductive or no substrate design), then the collector **204** may be integrated directly into the active layer **203**. For example, the collector **204** may be crimped over a part of the active layer **203**. In some embodiments, the current collector **204** may also serve structural functions. For example, a current collector **204** may form a rigid mandrel onto which a jellyroll is wound. In the same or another example, a casing may be used for conducting electrical current to one of the cell electrical terminals.

[0057] The nanostructures **200** may have different shapes and be arranged in different ways within the active layer **203**. Several illustrative embodiments are presented in FIGS. 2A-2B. One of the shapes is now described in more details. It should be understood that the following description is not limited in all respects to this shape. FIG. 1A shows one example of the nanostructures **200** having elongated tapered shapes with wider ends **207** growth rooted into the substrate **102**. Such structures may be formed, for example, using a CVD process over a substrate deposited with a catalyst.

[0058] Anode nanostructures may swell during charging. Silicon has been reported to swell by as much as 400% causing pulverization that negatively impacts electrode resistance and capacity. Anode designs based on smaller silicon particles require substantial quantities of binding and conductive media also negatively affecting capacity, and other performance criteria and do not solve the conductivity problem. Further, insulating SEI layers are formed around breakages and cracks resulting in a poor cycle life and high irreversible capacity losses. It has been found that depositing active materials having certain nano-scale dimensions and shapes may help reducing internal stresses during lithiation below the fracture limits while retaining desirable mechanical and electrical properties. These materials are generally referred to in this description as nanostructures. Additional improvement may come from certain configurations of the nanostructure in the active layer **203** and composition of the nanostructures. These parameters will now be discussed in details.

[0059] In certain embodiments, nanostructures **200** define an active layer **203** having certain properties, such as thickness and porosity. Porosity of an active layer is a measure of void spaces to the overall volume to the layer before the first cycle of the cell. For example, porosity of an anode is determined before any insertion of lithium ions occurs. It can be expressed as a percentage of the void volume to the total volume. In certain embodiments, the porosity of the active layer is at least about 10%, or more specifically at least about 20%, at least about 30%, at least about 40%, at least about 50%, or at least about 60%. In even more specific embodiments, the porosity may be at least about 75%, or more specifically at least about 90%. Greater porosity may allow more swelling of the nanostructures during cycling.

[0060] The thickness of the active layer **203** may change during cycling. Swelling of the nanostructures may exceed the porosity of the active layer causing the layer to expand. Additionally, certain arrangements of the nanostructure may cause the active layer to increase its thickness even though

some void space remains in the layer. An active layer may change its thickness by no greater than 100%, or more specifically by no greater than 50%, between charge and discharge states.

[0061] FIG. 2C is a top schematic view of an electrode illustrating different cross-section shapes and dimensions of the nanostructures 208. In certain embodiments, nanostructures have one dimension that is substantially larger than the other two. The largest dimension is referred to as a length. Some nanostructures, especially ones with high aspect ratios, may have curved shapes. In these cases, the length of the nanostructure is the length of the representative curve. A cross-section is defined as a profile of a nanostructure in a plane perpendicular to the length. Nanostructures may have many varying cross-sectional (transverse) thicknesses along their lengths. Further, an active layer may have nanostructures with different cross-sections, both shapes and dimensions. For example, FIG. 2C illustrates cross-section examples of the tapered nanostructures 208. For these nanostructures, the cross-section near the substrate-rooted end 207 is greater than near the free end. Examples of nanostructure shapes include spheres, cones, rods, wires, arcs, saddles, flakes, ellipsoids, etc.

[0062] Cross-sectional shapes are generally dependent on compositions, crystallographic structures (e.g., crystalline, amorphous), sizes, deposition process parameters, and many other factors. Shapes may also change during cycling. Irregularities of cross-sectional shapes require a special dimensional characterization. For the purposes of this application, a cross-section dimension 209 is defined as a distance between the two most separated points on a periphery of a cross-section that is transverse to the principal dimension, such as length. For example, a cross-section dimension of a cylindrical nano-rod circle is the diameter of the circular cross-section. In certain embodiments, a cross-section dimension of nanostructures is between about 1 nm and 10,000 nm. In more specific embodiments, a cross-section dimension is between about 5 nm and 1000 nm, and more specifically between 10 nm and 200 nm. Typically, these dimensions represent an average or mean across the nanostructures employed in an electrode.

[0063] In certain embodiments, nanostructures are hollow. They may be also described as tube or tube-like structures. Therefore, the cross-sectional profile of these hollow nanostructures includes void regions surrounded by annular solid regions. An average ratio of the void regions to the solid regions may be between about 0.01 and 100, more specifically between about 0.01 and 10. The cross-section dimension of the hollow nanostructures may be substantially constant along the principal dimension (e.g., typically the axis). Alternatively, the hollow nanostructures may be tapered along the principal dimension. In certain embodiments, multiple hollow nanostructures may form a core-shell arrangement similar to multiwall nanotubes.

[0064] The cross-section dimension may vary along the length of nanostructures. FIG. 2D illustrates side profile examples of nanostructures in accordance with certain embodiments. Unless otherwise specified, a cross-section dimension of a nanostructure refers to an average cross-section dimension along the entire length of a nanostructure. The cross-section dimension may vary along the length in a variety of different ways. FIG. 2B shows nanostructures 210 and 212 with the substrate rooted ends having larger cross-section dimensions than the free ends. Such tapering may

result from gradual catalyst exhaustion and side-wall growth during the deposition. For example, the catalyst may evaporate because of high temperatures, e.g., at least about 500° C. for a gold catalyst, used during the deposition. Another example may be a tapered nanostructure 216 with the substrate-rooted end having a smaller cross-section dimension than the free end. In some embodiments, a nanostructure 218 has a narrow neck somewhere along the length and tapers from this neck towards both ends. For example, such shapes may be achieved by varying precursor flow rates and other process parameters. An average taper for the entire length of the nanostructure may be less than 10 degrees and more specifically even less than about 5 degrees.

[0065] Nanostructures can also differ in length. Often it is helpful to describe nanostructures in terms of their aspect ratio, i.e., a principal dimension divided by a cross-section dimension.

#### Wire-Shaped Nanostructures

[0066] In certain embodiments, a “nanowire” is defined as a structure that has, on average, an aspect ratio of at least about four. In certain examples, the average aspect ratio may be at least about ten, at least about one hundred, or even at least about one thousand. In some cases, the average nanowire aspect ratio may be at least about ten thousand, and can even reach about one hundred thousand. Nanowire active materials can undergo substantial swelling without disrupting the overall structure of the active layer, provide better electrical and mechanical connections with the layer, and can be easily realized using the vapor-liquid-solid and vapor-solid template free growth methods or other templated methods.

[0067] Nanowires can be terminally rooted to the substrate to form an active layer 304 as illustrated in FIG. 3A. These type of nanowires 304 may be formed by any of a number of techniques. Growth rooted nanowires may be deposited using, e.g., a catalyst coated substrate that provides deposition sites for the nanowires. Interconnection between the nanowires and the substrate generally provides good electrical conductivity and allows, in certain embodiments, an active layer with no or very little binder. For example, a conventional anode in a lithium ion cell uses approximately 10-12% of binding material based on solvent-free weights of all active layer components. The active layer 105 in accordance to certain embodiments of the present invention includes less than about 5%, or more in more specific embodiments less than about 2%, of binding materials.

[0068] Sometimes a single layer of the nanostructures that are rooted onto the substrate may not provide adequate thickness of the active layer. For example, a high capacity application may require thickness of an active layer that is greater than the average lengths of the nanowires. Further, nanowires may curve and form acute angles with the substrate causing the thickness of the active layer to be less than an average length of the nanowires. One way to address this issue is to form multiple sub-layers of nanowires to form a single active layer. FIG. 3B illustrates an active layer example with partially growth-rooted nanostructures having wire-like shapes. Some nanostructures 306 of the active layer may be rooted to the substrate 102, while others 308 may not have direct contact with the substrate. Non-substrate rooted nanostructures 308 may be interconnected with substrate-rooted nanostructures 306 through direct (e.g., metallic) bonds or additives. In certain embodiments, such

layer may be formed first by creating substrate-rooted nanostructures **306**, for example using CVD. New nucleation points may then be created on the substrate-rooted nanostructures **306** by additional deposition of the catalysts on the deposited nanowires using sputtering or other deposition techniques or re-deposition of the catalyst remaining from the substrate rooted growth. The deposition can then continue by forming secondary nanostructures **308** (e.g., nanowires) over the growth-rooted ones **306**. Secondary nanostructures **308** are indirectly coupled to the substrate **102** via the primary, substrate-rooted nanostructures **306**. In certain embodiments, the coupling between structures **306** and **308** is a direct electronic connection that allows electrons or holes to flow unimpeded between the structures. Because the nanostructures **306** may be substrate rooted to substrate **102**, a highly conductive pathway exists between distal regions of structures **308** and substrate **102**. This tight electrical coupling among electroactive nanostructures comprising the active layer allows for electrode designs requiring relatively little conductivity enhancing additives such as carbon.

**[0069]** In alternative embodiments, secondary nanostructures **308** may be connected to the substrate-rooted sub-layer or directly to the substrate using binders. In certain embodiments, an active layer may include between about 2 weight percent and 25 weight percent of one or more binders based on a solid content of the layer, or more specifically between about 5 weight percent and 10 weight percent. Binders may be soluble in aqueous or non-aqueous solvents, which are used during fabrication. Some examples of “non-aqueous binders” include poly(tetrafluoroethylene) (PTFE), poly(vinylidene fluoride) (PVDF), styrene-butadiene copolymer (SBR), acrylonitrile-butadiene copolymer (NBR) or carboxymethyl cellulose (CMC), polyacrylic, and polyethylene oxide, and combinations thereof. Examples of “aqueous binders” include carboxymethyl cellulose and poly (acrylic acid), acrylonitrile-butadiene copolymer latex, polyacrylamide in combination with carboxylated styrene-butadiene copolymer and/or styrene-acrylate copolymer. In another specific example, the binder may include a fluoropolymer and a metal chelate compound. The fluoropolymer may be polymerized from fluorinated monomers, such as vinyl fluoride (VF), vinylidene fluoride (VdF), tetrafluoroethylene (TFE), trifluoroethylene (TrFE), chlorotrifluoroethylene (CTFE), fluorinated vinyl ethers, fluorinated alkyl acrylates/methacrylates, perfluoroolefins having 3-10 carbon atoms, perfluoro C1-C8 alkyl ethylenes and fluorinated dioxoles.

**[0070]** FIGS. 4A-4C show different illustrative examples of interconnecting the nanostructures. Interconnecting improves electrical conductivity of the active layer, provides mechanical attachment eliminating the need of a binder, and allows deposition of thicker active layers. FIG. 4A illustrates an interconnection example in which multiple nanowire fingers **402a-d** are grown from a central connection or nucleation site **404**. This site may be formed, for example, by a catalyst particle, direct un-catalyzed nucleation, or an irregularity in the crystalline structure. The process may involve, for example, operations of re-depositing the remaining catalyst (or deposition of the new catalyst) after the first batch of the nanowires has been deposited, heat treating the catalyst to form a plurality of droplets, and incorporating metallic nanoparticles.

**[0071]** FIG. 4B illustrates an interconnected nanostructure having multiple nanostructure fingers where one central

nanostructures **406** serves as a backbone to which other nanostructure fingers **408** are attached. For example, the nucleation points **410** may be created along the length of the backbone nanostructure **406** after its deposition. This may be achieved by coating additional catalyst on a layer of deposited nanostructures, for example.

**[0072]** FIG. 4C illustrates an interconnection example among multiple nanostructures **420** using additives **422**, for example conductive additives. Conductive additives can include carbonaceous material, such as coke, acetylene black, carbon black, Ketchen black, channel black, furnace black, lamp black and thermal black or carbon fibers, graphite, metallic flakes or particles of copper, stainless steel, nickel or other relatively inert metals, conductive metal oxides, such as titanium oxides or ruthenium oxides, or electronically-conductive polymers, such as polyaniline or polypyrrolein. The amount of conductive additive may be up to about 20 weight percent of the active layer, more specifically between about 1 to 10 weight percent. In the same or other embodiments, the additives **422** include one or more binders described above. Various forms of interconnections can be combined. For example, the direct interconnections presented in FIGS. 4A-4B may be supplemented with conductive additives and/or binders.

**[0073]** Groups of nanowires or other nanostructures may form an interconnected bundle, where the nanowires are closely positioned relative to each other along the length of the nanowires. Bundles may be formed when catalyst sites are close to each other on the conductive substrate surface prior to the deposition of the nanowires. Bundles may also be formed after the deposition when the nanowires are forced into the bundles during post-deposition treatment of the active layer. Generally, the individual structures of a bundle will be separated, on average, from one another by no more than about 300% of the average cross-section dimensions of the nanowires in the bundles, more specifically by no more than about 100%, or even more specifically by no more than about 30%.

**[0074]** Bundles may provide improved conductivity of the active layer. Nanowires in a bundle may touch each other along their lengths, and thereby form multiple electrical connections with each other. One or more nanowires in a bundle may be specifically provided to have higher conductivity than the others and thereby help other nanowires that comprise active materials to transfer charge to the conductive substrate. Further, if one or more nanowires in a bundle are separated from the conductive substrate, for example because of breakage, sufficient electrical and mechanical connection of the separated nanowires to the substrate will be provided by other nanowires in the bundles.

**[0075]** Bundles may also be used to provide an expansion volume for the nanowires in the bundle carrying the active material. For example, one or more nanowires in a bundle may keep its original size or even reduce in size when other nanowires expand during lithiation.

#### Materials

**[0076]** The nanostructures used in anodes may include one or more active materials, such as silicon, germanium, tin, tin oxide, titanium oxide, carbon, a variety of metal hydrides (e.g., MgH<sub>2</sub>), silicides, phosphides, and nitrides.

**[0077]** While silicon has received much of the attention as a next generation lithium insertion anode material, other materials may also be used with this invention. For example,

nanostructures may also include tin. Tin is relatively inexpensive and appears to undergo a smaller volume change than silicon during lithium ion insertion. Tin may be used as a sole active material or in combination with silicon or other materials. For example, tin-doped silicon, tin-coated silicon, silicon-coated tin, tin-silicon alloys, and the like may be used. Tin may also be combined with copper as an alloy (e.g., a bronze). As a lithium insertion material, elemental tin has a capacity of 960 mAh/g.

**[0078]** In other specific embodiments, nanostructures may include germanium. As a lithium insertion material, elemental germanium has a capacity of 1600 mAh/g, but the room-temperature diffusivity of lithium in germanium is about 400 times higher than that in silicon. Therefore, germanium is particularly attractive for high-rate applications. Germanium may be used as a sole active material or in combination with silicon and/or tin. For example, silicon-coated germanium structures, germanium-coated silicon structures, tin-coated germanium structures, germanium-coated tin structures, germanium-doped tin, tin-doped germanium, and the like may be used as in anodes of lithium ion batteries.

**[0079]** Other active materials and combinations of the active materials may include: carbon-silicon combinations (e.g., carbon-coated silicon, silicon-coated carbon, carbon doped with silicon, silicon doped with carbon, and alloys including carbon and silicon), carbon-germanium combinations (e.g., carbon-coated germanium, germanium-coated carbon, carbon doped with germanium, and germanium doped with carbon), and carbon-tin combinations (e.g., carbon-coated tin, tin-coated carbon, carbon doped with tin, and tin doped with carbon).

**[0080]** The nanostructures used on cathodes may include one or more active materials, such as various lithium metal oxides (e.g.,  $\text{LiCoO}_2$ ,  $\text{LiFePO}_4$ ,  $\text{LiMnO}_2$ ,  $\text{LiNiO}_2$ ,  $\text{LiMn}_2\text{O}_4$ ,  $\text{LiCoPO}_4$ ,  $\text{LiNi}_{1/3}\text{Co}_{1/3}\text{Mn}_{1/3}\text{O}_2$ ,  $\text{LiNi}_x\text{Co}_y\text{Al}_z\text{O}_2$ ,  $\text{LiFe}_2(\text{SO}_4)_3$ ), carbon fluoride, metal fluoride, metal oxide, sulfur, and combination thereof. Doped and non-stoichiometric variations of these materials may be used as well.

#### Core-Shell Nanostructures

**[0081]** A nanostructure may include different materials (both active and non-active) and distribution of these materials within the nanostructure may vary as well. For example, each material may form its own layer within a nanostructure. FIG. 5A illustrates an example of a nanostructure where one material forms a “core” **502** and another material forms a “shell” **504** around the core. The nanostructure may have multiple shells as illustrated in FIG. 5B. It should be understood that any number of concentric shells may be used. Furthermore, a core may be a hollow (e.g., tube-like) structure. Typically, at least one of the materials in a core-shell is an active material. In one embodiment, a core-shell structure forms nested layers in a rod or wire, where one layer is surrounded by another outer layer, e.g., forming a set of concentric cylinders. In other embodiments, each layer of the nanostructure is a sheet that is rolled around itself and other layers to form a spiral. For simplicity, each of these embodiments is referred to as a core-shell structure.

**[0082]** In general the dimensions and shapes of core-shell nanostructures fall into the same ranges as discussed above for single material nanostructures. In one example, the average cross-section dimension of core-shell nanostructures may be between about 1 nm and 100  $\mu\text{m}$  and more

specifically between about 50 nm and 5  $\mu\text{m}$ . The transverse dimension (e.g., thickness or diameter) of each layer may be between about 1 nm and 10  $\mu\text{m}$  and more specifically between about 10 nm and 1  $\mu\text{m}$ . Of course, the thickness of one layer may differ from thicknesses of other layer.

**[0083]** The core **502** and the inner most shell **504** are generally made from two different materials or from different structures of the same material. In certain embodiments, the core **502** includes a silicon containing material, while the inner most shell **504** includes a carbon containing material. Carbon has good electrical conductivity, lithium ion insertion properties, and mechanical strength. Carbon shells may be permeable for lithium ions (e.g., 10 nm and 1  $\mu\text{m}$  thick). In certain embodiments, the carbon outer shell represents between about 1 and 5 weight percent of the entire nanostructure composition. Some lithium ions may be inserted into the carbon shell, while others may penetrate through the shell and be inserted into the silicon core. In the embodiments including multiple shells, lithium ions can further penetrate through the layer increasing the effective capacity of the nanostructures.

**[0084]** In certain embodiments, the core **502** includes a carbon containing material, while the shell **504** includes a silicon containing material. The silicon shell may be permeable to some lithium ions. Other materials may serve as the core and shell components of the structures, for example, the ones listed above.

**[0085]** In certain embodiments, the core and shell components include silicides and/or carbides, such as a zirconium carbide. Some of these materials may improve conductivity of the nanowires and may allow the layers of the core-shell nanostructure to expand during lithiation without destroying the overall structure of the nanowire. Some of the proposed materials that can be used in combinations with active materials in the core-shell arrangements may have good conductivity and/or be inert to the active ions in the electrolyte. Some materials, such as carbon, may provide additional lithiation sites and help to increase capacity of the overall nanowire. Amounts of materials in different layers of the core-shell arrangements may be determined based on conductivity, volume expansion, and other design considerations.

**[0086]** Carbon containing layers may be formed using methane, ethane, or any other suitable carbon containing precursors with or without catalysts. The precursors may be passed over nickel, chromium, molybdenum, or any other suitable catalysts and deposit a carbon layer over the catalyst. Carbon shell over silicon core nanostructures may be formed by depositing a catalyst onto the silicon surface (which may be a nanostructure formed by a conventional process). Examples of catalyst include gold, aluminum, tin, indium, lead, iron, nickel, titanium, copper, and cobalt. Carbon precursors are then flowed over the catalyzed silicon sub-structures to form a carbon layer. Furthermore, a carbon layer may be deposited by burning a natural gas (a combination of methane and other higher hydrocarbons) over a layer of silicon nanostructures. Other methods include coatings using organic media, which are later baked leaving carbon residue. For example, silicon nanowires may be dipped into a glucose or polymer solution. After allowing the solution to penetrate into the nanowire mesh, it is removed from the solution and baked. Glucose leaves carbon residues on the nanowires.

**[0087]** Nanostructures that include both silicon and carbon layers generally have better conductivity than nanostructures containing only silicon, allow additional expansion volume, and reduce stresses associated with swelling inside each nanostructure and between the nanostructures in the active layer. Carbon is a substantially less resistive element ( $1.375 \times 10^{-5} \Omega\text{m}$  for graphite) than silicon ( $6.40 \times 10^2 \Omega\text{m}$ ). The internal resistance of the nanostructures and the contact resistance between the abutting nanostructures can be substantially reduced by including carbon containing materials. Furthermore, carbon containing layers, for example, a graphite layer, can accommodate swelling of adjacent silicon containing layers. Without being restricted to any particular theory, it is believed that an interphase between two layers (e.g. a silicon containing layer and a carbon containing layer) may provide additional insertion points for lithium ions.

#### Doping

**[0088]** Some active materials, such as silicon, have high theoretical capacities, but also exhibit high electrical resistance. Conductivity can be improved by introducing conductive additives into an active layer. It has also been found that certain materials may also be doped during formation of nanostructure or during treatment of a deposited layer resulting in improved conductivity. For the purposes of this application, any addition of a conductivity enhancement component directly into the nanostructure is referred to as doping regardless of the concentration of the conductivity enhancement component. In certain embodiments, elements from the groups III and V of the periodic table are used as conductivity enhancement components in silicon containing nanostructures. For example, silicon containing nanostructures can be doped with one or more elements from the group consisting of boron, aluminum, gallium, indium, thallium, phosphorous, arsenic, antimony, and bismuth. It has also been found that certain conductivity enhancement components improve charge transfer properties of the active layer. Other dopant atoms besides group III or V atoms may be employed. Examples include sulfur, selenium, etc. Doped silicon has higher electron or hole density in comparison with un-doped silicon (e.g., Fermi level shifts into the conduction or valence band, resulting in higher conductivity).

**[0089]** In certain embodiments, silicon containing anode nanostructures are “doped” with lithium. Such doping helps to compensate for losses of lithium during formation of a solid electrolyte interphase (SEI) layer. It should be understood that a cathode nanostructure may also be doped with lithium. In either case, the lithium is generally considered as distinct from the electrochemically active lithium ions that shuttle between the anode and cathode during cell cycling. The lithium dopant atoms may be inserted during an initial charge or discharge cycle and can be viewed as irreversible capacity loss.

**[0090]** Depending on the concentration of materials introduced into silicon containing nanostructures, the resulting nanostructure may be transformed into a semiconductor (concentration is between about  $10^{14}$  and  $10^{19}$  atoms per centimeter cubed), a highly doped metalized conductive silicon (concentration is between about  $10^{19}$  and  $10^{21}$  atoms per centimeter cubed), or a silicon alloy (concentration is greater than about  $10^{21}$  atoms per centimeter cubed). Higher concentration is usually desirable for higher conductivity.

For the purposes of this application, any foreign material incorporated into base materials of the nanostructure is referred to as a dopant regardless of the concentration. More than one dopant material may be used. In certain embodiments, one or more dopants have concentration of between about  $10^{14}$  and  $10^{19}$  atoms per centimeter cubed. In other embodiments, one or more dopants have concentration of between about  $10^{19}$  and  $10^{21}$  atoms per centimeter cubed. In yet another embodiment, concentration is between about  $10^{21}$  and  $10^{23}$  atoms per centimeter cubed.

**[0091]** Various methods may be used to introduce dopants (i.e., doping) into the nanostructures. For example, a gas phase doping involves introducing dopant containing precursors together with base material precursors, such as silane for silicon nanostructures. Relative flow rates of precursors may vary during deposition to achieve dopant concentration gradients within the nanostructures. For example, a mixture of hydrogen, silane, and about 10 ppm of phosphine may be flowed into the deposition chamber. Silane decomposes at catalyst sites and forms silicon wires. The phosphine similarly decomposes and leaves phosphorus that incorporates into the silicon nanostructures as a dopant by replacing silicon in some lattice sites.

**[0092]** Another method for doping involves spin-on coating. For example, an organic polymer containing dopants may be coated over a layer of deposited nanostructures. The coated nanostructures are then baked at between about  $200^\circ\text{C}$ . and  $600^\circ\text{C}$ . for between about 20 and 30 minutes. The organic polymer decomposes into gases that are removed from the baking chamber leaving dopant on the nanostructures. Some dopant may diffuse into the nanostructures.

**[0093]** Dopants may also be introduced using ion implantation. This process includes generating dopant ions, accelerating the ions in the electrical field (e.g., 1 to 500 keV), and bombarding a nanostructure layer with the accelerated ions. Some of the dopant ions penetrate into nanostructures. Controlling electrical fields may be used to provide dopant concentration gradients within nanostructures and even to modify morphological structure of the nanostructures.

**[0094]** Another doping method includes evaporating a dopant during the nanostructure formation and trapping some of the evaporated dopant in the newly formed nanostructures. For example, aluminum and indium may dope silicon nanostructures using this method. A temperature range for evaporation may be between about  $150^\circ\text{C}$ . and  $700^\circ\text{C}$ ., depending on the material to be evaporated.

**[0095]** In certain embodiments, dopants are evenly distributed throughout the entire volume of the nanostructures, i.e., dopants have a uniform concentration distribution as illustrated with line **614** in FIG. 6. Such uniform distribution may result, for example, from dopants being introduced during deposition of the nanostructures. In other embodiments, dopant concentration may be greater near the outer surface of the nanostructures. Two examples of dopant concentration distributions are illustrated with lines **610** and **612** in FIG. 6. For example, dopants may naturally segregate to the surface when gas phase precursors are used in CVD formation of the active layer containing nanostructures. Also, if the doping operation follows the deposition operation, then the dopants are introduced into the structures from the surface and diffuse into the structures creating a dopant concentration profile that is typically higher around the surface.

[0096] Dopants may also be unevenly distributed along the length of nanostructures. For example, nanostructures may have higher dopant concentration resulting in higher conductivity near the growth-rooted ends where the electrical current flow is the highest. Varying dopant concentration may be achieved by varying relative flow rates of dopant-containing precursors during the deposition operation.

#### Crystalline and Amorphous Structures

[0097] A nanostructure may be deposited as a single crystal, multiple crystals combined together, a predominantly amorphous structure, or a combination of crystals and amorphous structures. Often, initially deposited crystalline structures are later transformed into amorphous structures during initial cycling of the cell. FIG. 7 illustrates an example of a crystalline nanostructure 704 deposited onto the substrate 102. During cycling the nanostructure 704 is transformed into a predominantly amorphous structure 706. The amorphous structure 706 may have a few remaining crystals. Often such transformation corresponds to some capacity loss.

[0098] In certain embodiments, the nanostructures are deposited in a predominantly amorphous form. Without being restricted to any particular theory, it is believed that eliminating initial structural transformation helps to reduce initial capacity loss. For example, a silicon layer of the nanostructure deposited over the carbon layer may assume a naturally amorphous state directly upon the deposition, thereby avoiding the need to convert from a crystalline to an amorphous state during an initial cycle. For example, silicon deposited over the surface of a carbon nanostructure (to form core-shell nanostructures) using a thermal CVD or PECVD method may form an amorphous silicon.

#### Fabrication Methods

[0099] FIG. 8 illustrates an example of a method for depositing growth-rooted nanostructures in accordance with certain embodiments. The process may start with providing a substrate (block 802) that could include one or more substrate materials and have one or more structure (e.g., a foil, mesh, particles) described above. The substrate may be specially treated to modify its surface properties, such as roughness and surface resistance. Further, the substrate may be treated with certain precursors to provide improved adherence of the nanostructures to the substrate after deposition. For examples, precursors containing titanium, tellurium, chromium, nickel, and/or copper may be used. Some of these materials may be also used to form a diffusion barrier layer between the catalyst and the substrate to prevent or, at least, inhibit allying of the catalyst material with the substrate material. Selection of the precursors depends on the substrate, material, catalyst, and process parameters. Additionally, the substrate may be processed prior to the deposition as described above (e.g., surface may roughen, patterned, textured, chemically treated) to improve adhesion and other properties of the electrode.

[0100] After the substrate has been provided and appropriately treated (if necessary), the substrate may be contacted with a catalyst to form catalytic sites that promote growth-rooted nanostructure formation. Selection of the catalyst usually depends on a targeted composition, shape, and other properties of the nanostructures. A catalyst for depositing silicon nanostructures may be discrete particles

or patches or a continuous layer of gold, aluminum, indium, gallium, tin, iron, nickel, titanium, and/or iridium.

[0101] The nanostructures may be then deposited onto the substrate (block 804). For example, in a CVD process a silane may be passed over a substrate at a temperature of between about 300° C. and 700° C. and a pressure of between about 1 Torr and 760 Torr FIG. 9 illustrates a nanostructure example during different deposition stages. First, an initial catalyst site 904a may be deposited onto the substrate 102. Precursors containing nanostructure materials are then flowed over the catalyst 904a to deposit an initial nanostructure 906b on the substrate surface, i.e., between the catalyst and the substrate. Some of the catalyst 904a may evaporate or diffuse into the deposited structure resulting in a smaller remaining catalyst site 904b. For example, gold catalyst starts evaporating at temperatures of about 500° C., while gallium and indium evaporates at even lower temperatures. Lower deposition temperatures may help to prevent evaporation and cause most of the catalyst to remain on the top of the growing nanostructure leading to a more cylindrical shape. In certain embodiments, some catalyst 908b-d may become a part the nanostructure. If the catalyst is consumed through evaporation and/or entrapment into the nanostructure, the footprint of the catalyst site 904b-d may gradually decrease causing the cross-section of the deposited nanostructures to decrease accordingly. At the end of the deposition process, the nanostructure may have some remaining catalyst 904d.

[0102] Returning to FIG. 8, the nanostructures may be doped either during or after deposition, or both. In certain embodiments, the nanostructures are doped after deposition (block 806) using, for example, spin-on doping or ion implantation. In other embodiments, the doping is performed during deposition of the nanostructure. Doping may be performed in accordance with embodiments described above.

[0103] In certain embodiments, the nanostructures may be etched from larger bodies containing nanostructure materials. For example, a continuous layer of silicon may be deposited over a substrate. A photoresist may be then applied to the areas representative of nanostructures followed by etching between nanostructures using suitable chemical compounds of areas.

[0104] An electrode generally includes a conductive substrate that forms a continuous support structure. In certain embodiments, nanowires are first deposited onto a continuous substrate sheet, and the sheet is then cut into a shape determined by the cell design. In other embodiments, nanowires may be first deposited onto discrete particles that are then impregnated or otherwise attached to a substrate sheet or used to form a substrate sheet.

#### Apparatus

[0105] FIG. 10 illustrates an example of a CVD apparatus 1000 that may be used for depositing nanostructures in accordance with certain embodiments. This may be an atmospheric plasma deposition apparatus. As shown, the apparatus 1000 includes a process chamber 1002, which encloses other components of the reactor and serves to contain the plasma, if one is used. For example, the apparatus may include plasma generator 1004 that supplies RF power to a distribution head through which precursors 1008 are fed. Alternatively, no RF power may be supplied. The precursors 1008 are usually pre-mixed in a mixing bowl



**1010** to provide uniform mixture of precursors and inert materials when delivered into the process chamber **1002** through the showerhead **1006**. Appropriate valving and mass flow control mechanisms are employed to ensure that the correct gases are delivered during the deposition process. In case the chemical precursor(s) is delivered in the liquid form, liquid flow control mechanisms are employed. The liquid is then vaporized and mixed with other process gases during its transportation in the mixing bowl **1010** before reaching the deposition chamber **1002**.

**[0106]** The chamber **1002** may include a roll-to-roll substrate feeding system with an unwinding roll **1012** and a rewinding roll **1014**. The substrate may be pre-treated with catalysts (e.g., gold, aluminum, iridium, etc.) and provided on the unwinding roll **1012**. In certain embodiment, the catalyst treatment is performed in a CVD apparatus.

**[0107]** The substrate **1015** may be fed over a heater **818** positioned under the showerhead where most of the deposition occurs. Generally, the substrate **1016** is maintained at a temperature in a range of between about 25° C. and 500° C., preferably in a range of between about 350° C. and 425° C., when passing over the heater.

**[0108]** Process gases exit the chamber **1002** via an outlet **1020**. A vacuum pump **1022** typically draws process gases out and maintains a suitably low pressure, if used within the reactor, by a close loop controlled flow restriction device, such as a throttle valve or a pendulum valve. In a method in accordance with the invention, pressures in the reaction chamber **1002** generally are maintained in a range of between about 100 Torr and 760 Torr, more specifically in a range of between about 300 Torr and 760 Torr.

**[0109]** In certain embodiments, a system controller **1024** is employed to control process conditions during deposition of nanostructures and other process operations. The controller will typically include one or more memory devices and one or more processors. The processor may include a CPU or computer, analog and/or digital input/output connections, stepper motor controller boards, etc. In certain embodiments, the controller controls all of the activities of the reactor. The system controller executes system control software including sets of instructions for controlling the timing of the processing operations, pressure, precursor flow rates, temperatures of the heater, vacuum pump, plasma generator, etc. Typically, there will be a user interface associated with controller **1024**. The user interface may include a display screen, graphical software displays of the apparatus and/or process conditions, and user input devices such as pointing devices, keyboards, touch screens, microphones, etc.

**[0110]** The computer program code for controlling the processing operations can be written in any conventional computer readable programming language: for example, assembly language, C, C++, Pascal, Fortran or others. Compiled object code or script is executed by the processor to perform the tasks identified in the program. The controller parameters relate to process conditions such as, for example, timing of the processing steps, flow rates and temperatures of precursors and inert gases, temperature of the substrate, pressure of the chamber and other parameters of a process. These parameters are provided to the user in the form of a recipe, and may be entered utilizing the user interface. Monitoring the process may be provided by analog and/or digital input connections of the system controller.

**[0111]** The system software may be designed or configured in many different ways. For example, various chamber

component subroutines or control objects may be written to control operation of the chamber components for carrying out the inventive deposition processes. Examples of programs or sections of programs for this purpose include substrate timing of the processing steps code, flow rates, and temperatures of precursors and inert gases code, and a code for pressure of the chamber.

#### Cell Design

**[0112]** FIG. 11 illustrates a wound cell example showing example arrangement of cell components. A jellyroll includes a spirally wound positive electrode **1102**, a negative electrode **1104**, and two sheets of the separator **1106**. The positive electrode **1102** and/or negative electrode **1104** may include nanostructures in accordance with certain embodiments described above. For example, the negative electrode **1104** may include silicon nanowires growth-rooted on the stainless steel foil. The positive electrode may include an active layer with a combination of lithium cobalt oxide (or any other suitable lithium containing compound), conductive additive (e.g., acetylene black, Super P) and polymer binder (e.g., PVDF). The active layer may have density of between about 0.001 g/cm<sup>2</sup> and 0.030 g/cm<sup>2</sup> and deposited over 5-40 μm aluminum foil.

**[0113]** The jellyroll is inserted into a cell case **1116**, and a cap **1118** and gasket **1120** are used to seal the cell. In some cases, the cap **1112** or case **1116** includes a safety device. For example, a safety vent or burst valve may be employed to break open if excessive pressure builds up in the battery, such as a current interrupting device. Also, a positive thermal coefficient (PTC) device may be incorporated into the conductive pathway of cap **1118** to reduce the damage that might result if the cell suffered a short circuit. The external surface of the cap **1118** may be used as the positive terminal, while the external surface of the cell case **1116** may serve as the negative terminal. In an alternative embodiment, the polarity of the battery is reversed and the external surface of the cap **1118** is used as the negative terminal, while the external surface of the cell case **1116** serves as the positive terminal. Tabs **1108** and **1110** may be used to establish a connection between the positive and negative electrodes and the corresponding terminals. Appropriate insulating gaskets **1114** and **1112** may be inserted to prevent the possibility of internal shorting. For example, a Kapton™ film may be used for internal insulation. During fabrication, the cap **1118** may be crimped to the case **1116** in order to seal the cell. However prior to this operation, electrolyte (not shown) is added to fill the porous spaces of the jellyroll.

**[0114]** An electrolyte may be a lithium containing salt dissolved in a solvent at concentration of between about 0.3M and 2.5M; more specifically between about 0.7M and 1.5M. One or more salts may be selected from the group including: LiPF<sub>6</sub>, LiBF<sub>4</sub>, LiClO<sub>4</sub>, LiAsF<sub>6</sub>, LiN(CF<sub>3</sub>SO<sub>2</sub>)<sub>2</sub>, LiN(C<sub>2</sub>F<sub>5</sub>SO<sub>2</sub>)<sub>2</sub>, LiCF<sub>3</sub>SO<sub>3</sub>, LiC(CF<sub>3</sub>SO<sub>2</sub>)<sub>3</sub>, LiPF<sub>4</sub>(CF<sub>3</sub>)<sub>2</sub>, LiPF<sub>3</sub>(C<sub>2</sub>F<sub>5</sub>)<sub>3</sub>, LiPF<sub>3</sub>(CF<sub>3</sub>)<sub>3</sub>, LiPF<sub>3</sub>(iso-C<sub>3</sub>F<sub>7</sub>)<sub>3</sub>, LiPF<sub>5</sub>(iso-C<sub>3</sub>F<sub>7</sub>). One more or more solvent may be selected from the group including: ethylene carbonate (EC), propylene carbonate (PC), butylene carbonate (BC), vinylene carbonate (VEC), gamma-butyrolactone (GBL), gamma-valerolactone (GVL) alpha-angelica lactone (AGL), dimethyl carbonate (DMC), methyl ethyl carbonate (MEC), diethyl carbonate (DEC), methyl propyl carbonate (MPC), dipropyl carbonate (DPC), methyl butyl carbonate (NBC) and dibutyl carbonate (DBC), tetrahydrofuran (THF), 2-methyltetrahy-

dofuran, 1,4-dioxane, 1,2-dimethoxyethane (DME), 1,2-diethoxy ethane, 1,2-dibutoxyethane, acetonitrile, adiponitrile, methyl propionate, methyl pivalate, butyl pivalate and octyl pivalate, amides, dimethyl formamide, trimethyl phosphate, and trioctyl phosphate.

#### Experimental Example

**[0115]** Half cells were constructed with silicon nanowires grown on a stainless steel substrate as one electrode and lithium foil as the other electrode. The electrodes were arranged in the glass fixtures with 1.0 M LiPF<sub>6</sub> electrolyte mixed in equal parts of ethylene carbonate (EC) and diethyl carbonate (DEC) as solvent. The half cells were then tested to determine capacity retention after cycling. The results demonstrated that a capacity was about 3000 mAh/g after 20 cycles. Another set of half cells was subjected to longer cycling. The capacity of these cells was about 1000 mAh/g after 180 cycles.

#### Conclusion

**[0116]** Although the foregoing invention has been described in some detail for purposes of clarity of understanding, it will be apparent that certain changes and modifications may be practiced within the scope of the appended claims. It should be noted that there are many alternative ways of implementing the processes, systems, and apparatus of the present invention. Accordingly, the present embodiments are to be considered as illustrative and not restrictive, and the invention is not to be limited to the details given herein.

What is claimed is:

1. A lithium ion battery electrode comprising:  
a conductive substrate; and  
silicon containing nanowires substrate-rooted to the conductive substrate,  
the silicon containing nanowires having variable cross-sectional dimensions along the length of the silicon containing nanowires and having tapered profiles with wider ends and narrower ends,  
wherein the wider ends are substrate-rooted to the conductive substrates to provide conductive attachment and mechanical support to the silicon containing nanowires with respect to the conductive substrate.
2. The electrode of claim 1, wherein the silicon containing nanowires further comprise a silicide.
3. The electrode of claim 1, wherein the silicon containing nanowires further comprise a carbide.
4. The electrode of claim 1, wherein the silicon containing nanowires each comprise a silicide core and a silicon shell.
5. The electrode of claim 1, wherein the conductive substrate comprises nickel.

6. The electrode of claim 1, wherein the conductive substrate is provided in the form of a structure selected from the group consisting of a mesh, a perforated sheet, a foam, and a felt.

7. The electrode of claim 1, the silicon containing nanowires comprise substrate-rooted cores and a layer of an electrochemically active material coating the substrate-rooted cores.

8. The electrode of claim 7, wherein the electrochemically active material comprises a material selected from the group of consisting silicon, tin, and germanium.

9. The electrode of claim 8, wherein the substrate-rooted cores comprise a silicide, and wherein the electrochemically active material consists essentially of silicon.

10. The electrode of claim 1, further comprising a shell coating the silicon containing nanowires.

11. The electrode of claim 10, wherein the shell comprising a carbon-containing material.

12. The electrode of claim 1, wherein the silicon containing nanowires each contains a narrow neck located between a substrate-rooted end and a free end of the silicon containing nanowires.

13. The electrode of claim 1, wherein the silicon containing nanowires have an average aspect ratio of at least about ten.

14. The electrode of claim 1, wherein the silicon containing nanowires have an average cross-sectional dimension of between about 1 nanometer and 10 microns on average.

15. The electrode of claim 1, wherein the silicon containing nanowires form a layer over the conductive substrate, the layer having porosity of less than about 75 percent.

16. The electrode of claim 1, wherein the silicon containing nanowires have an average length of at least about 100 micrometers.

17. The electrode of claim 1, wherein the silicon containing nanowires consist essentially of silicon.

18. The electrode of claim 1, wherein the average cross-sectional dimension of the wider ends is below the silicon fracture.

19. The electrode of claim 1, wherein the silicon containing nanowires are growth-rooted to the substrate.

20. A lithium ion battery comprising:  
a negative electrode comprising a conductive substrate and silicon containing nanowires substrate-rooted to the conductive substrate,  
the silicon containing nanowires having variable cross-sectional dimensions along the length of the silicon containing nanowires and having tapered profiles with wider ends and narrower ends,  
wherein the wider ends are substrate-rooted to the conductive substrates to provide conductive attachment and mechanical support to the silicon containing nanowires with respect to the conductive substrate.

\* \* \* \* \*