



US 20180326221A1

(19) **United States**

(12) **Patent Application Publication**  
**Deisseroth et al.**

(10) **Pub. No.: US 2018/0326221 A1**

(43) **Pub. Date: Nov. 15, 2018**

(54) **SYSTEM FOR OPTICAL STIMULATION OF TARGET CELLS**

**Publication Classification**

(71) Applicant: **The Board of Trustees of the Leland Stanford Junio Junior University,**  
Stanford, CA (US)

(51) **Int. Cl.**  
*A61N 5/06* (2006.01)  
*A61K 48/00* (2006.01)  
*A61K 41/00* (2006.01)

(72) Inventors: **Karl Deisseroth,** Stanford, CA (US);  
**Feng Zhang,** Cambridge, MA (US);  
**David J. Mishevich,** Playa Del Rey,  
CA (US); **M. Bret Schneider,** Portola  
Valley, CA (US)

(52) **U.S. Cl.**  
CPC ..... *A61N 5/0622* (2013.01); *A61K 48/0083*  
(2013.01); *A61N 5/062* (2013.01); *A61N*  
*2005/0651* (2013.01); *A61K 41/0019*  
(2013.01); *A61K 48/0058* (2013.01); *A61K*  
*48/005* (2013.01); *A61N 5/0601* (2013.01)

(21) Appl. No.: **16/041,647**

(57) **ABSTRACT**

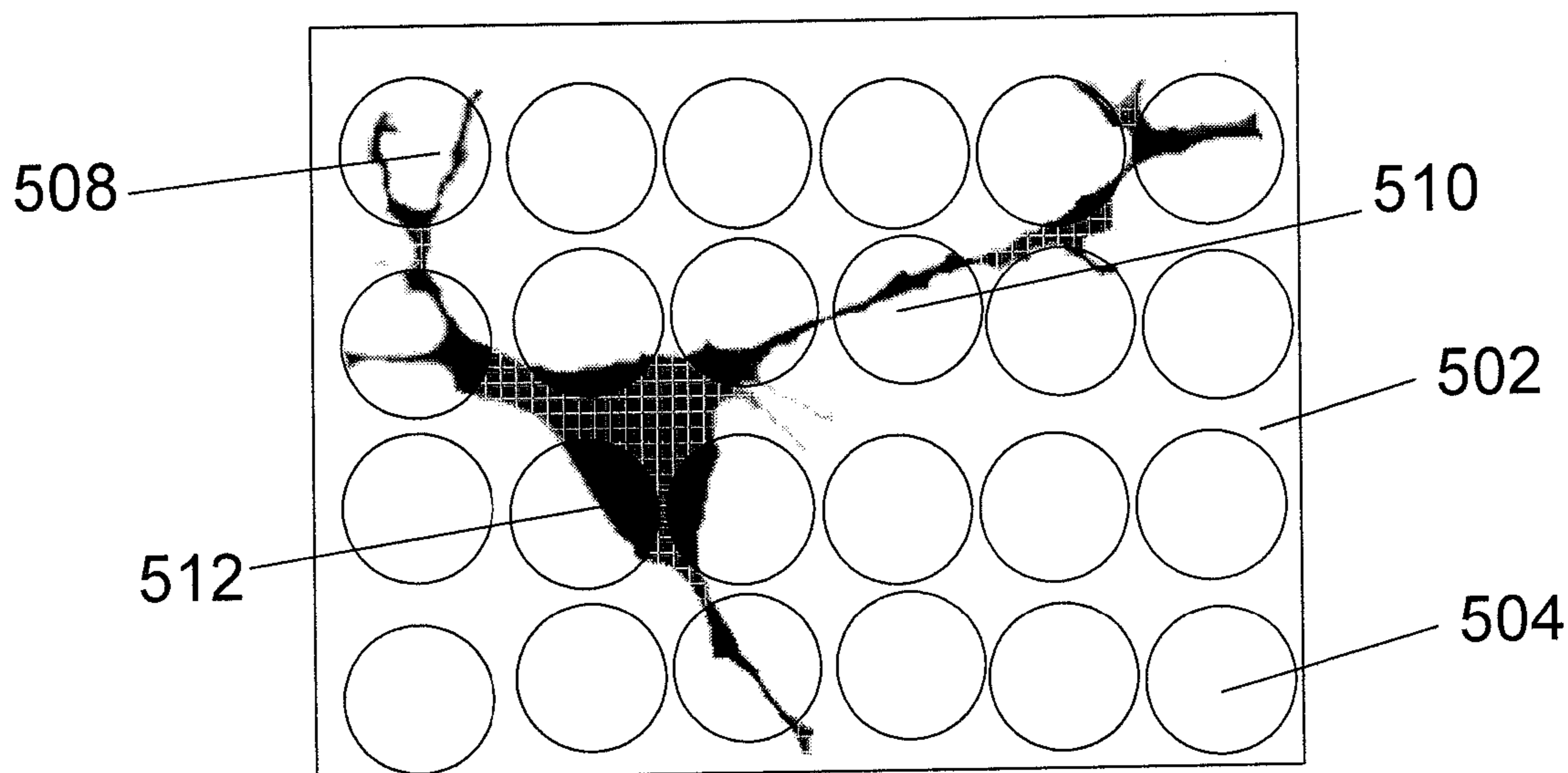
(22) Filed: **Jul. 20, 2018**

**Related U.S. Application Data**

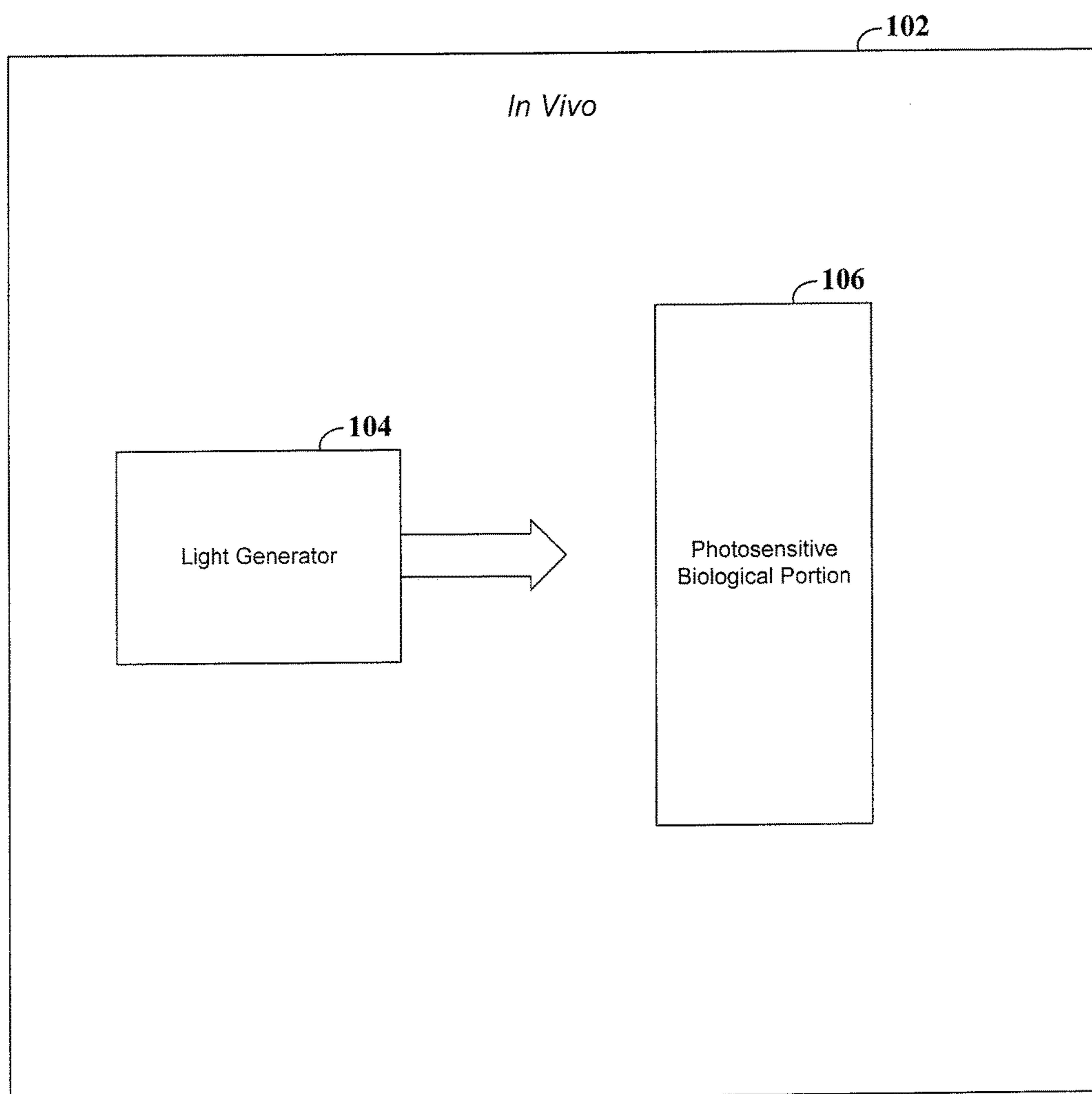
(63) Continuation of application No. 12/522,528, filed on Apr. 6, 2010, now Pat. No. 10,052,497, filed as application No. PCT/US2008/050628 on Jan. 9, 2008, which is a continuation of application No. 11/651,422, filed on Jan. 9, 2007, now Pat. No. 8,926,959, which is a continuation-in-part of application No. 11/459,636, filed on Jul. 24, 2006, now Pat. No. 8,906,360.

(60) Provisional application No. 60/955,116, filed on Aug. 10, 2007, provisional application No. 60/904,303, filed on Mar. 1, 2007, provisional application No. 60/879,669, filed on Jan. 10, 2007, provisional application No. 60/701,799, filed on Jul. 22, 2005.

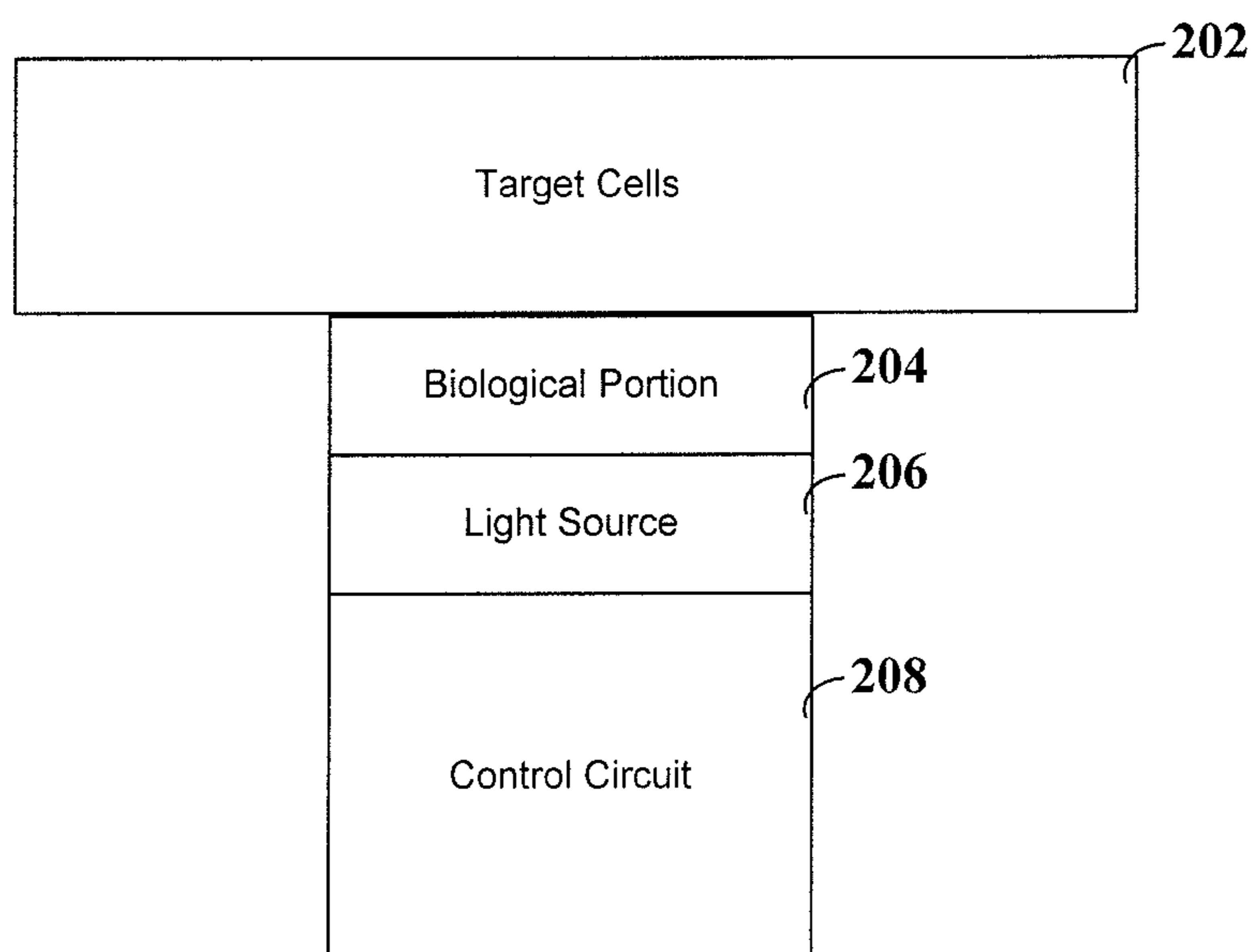
Stimulation of target cells using light, e.g., in vivo, is implemented using a variety of methods and devices. In one example, embodiments involve methods for stimulating target cells using a photosensitive protein that allows the target cells to be stimulated in response to light. In another specific example embodiment, target cells are stimulated using an implantable arrangement. The arrangement includes an electrical light-generation means for generating light and a biological portion. The biological portion has a photosensitive bio-molecular arrangement that responds to the generated light by stimulating target cells in vivo. Other aspects and embodiments are directed to systems and methods for screening chemicals based screening chemicals to identify their effects on cell membrane ion channels and pumps, and to systems and methods for controlling an action potential of neuron (e.g., in vivo and in vitro environments).

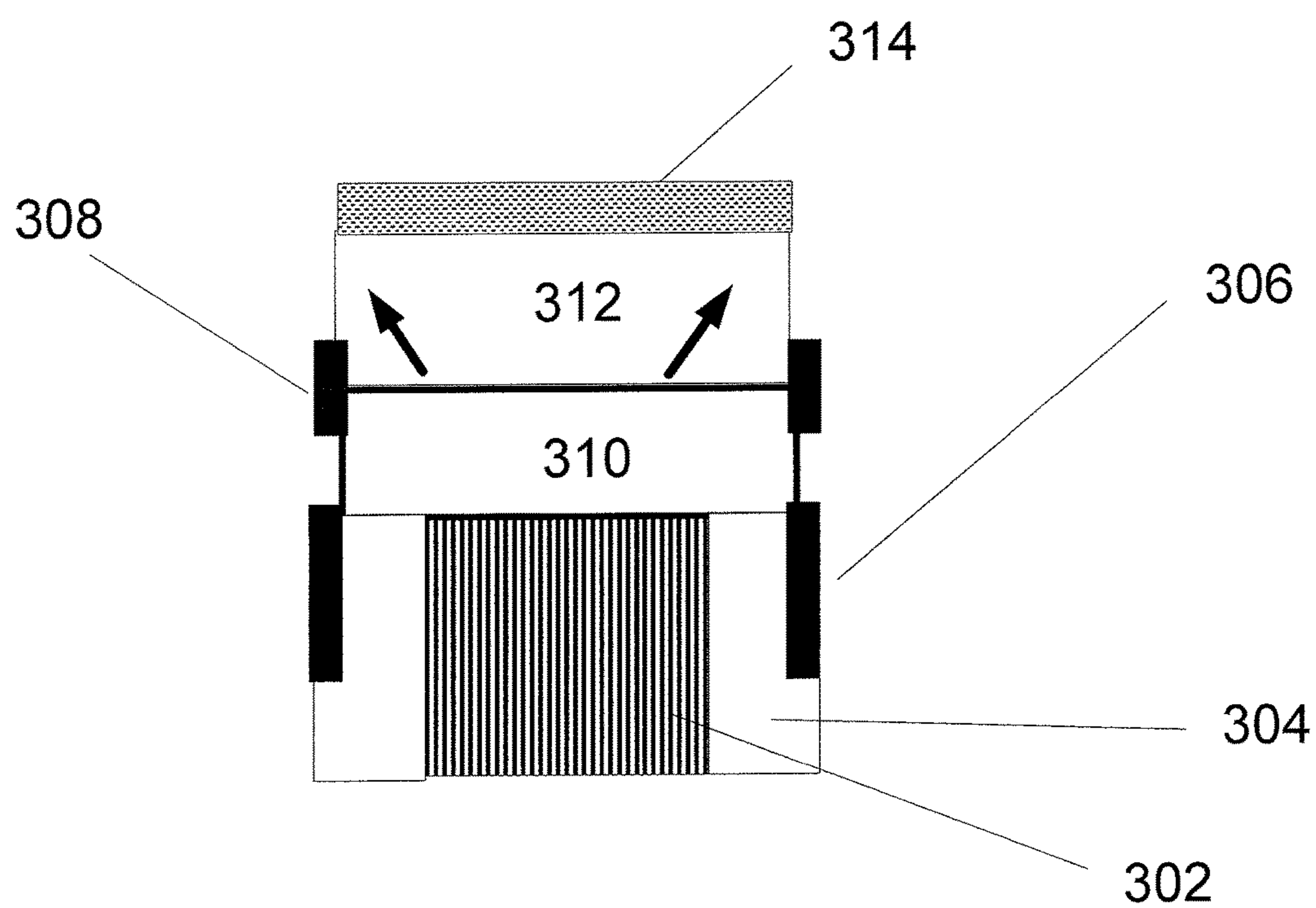


**FIG. 1**

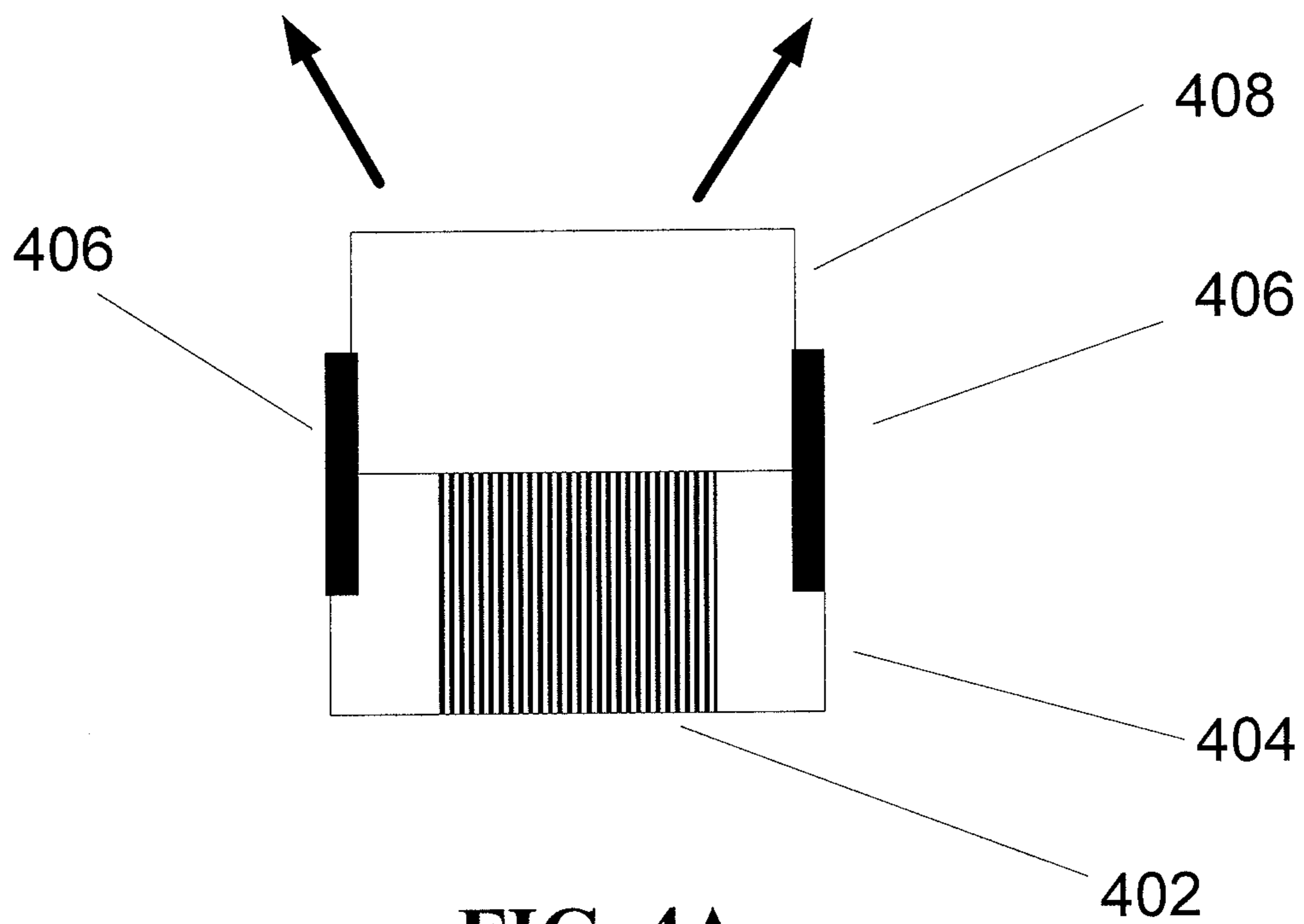


**FIG. 2**

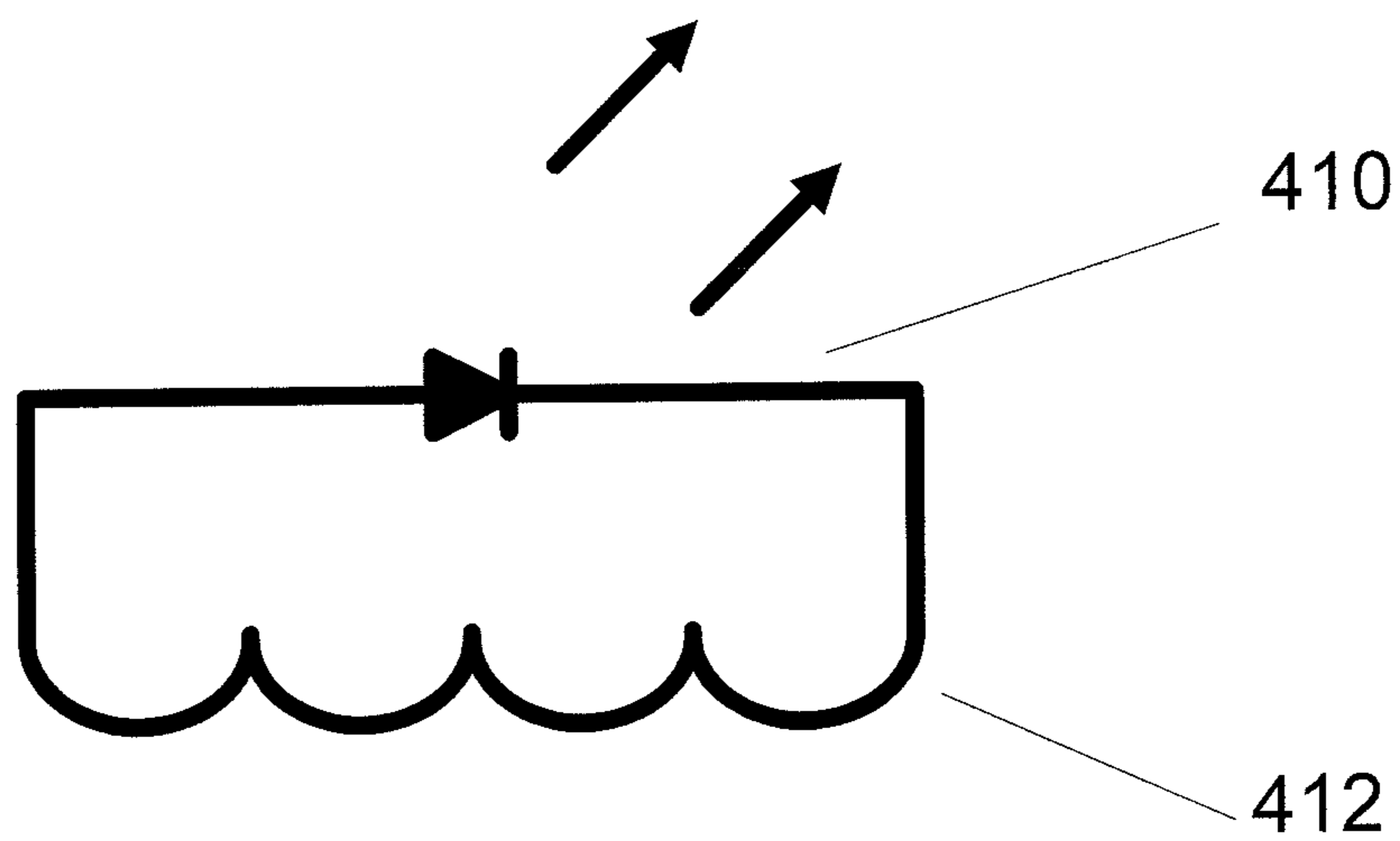




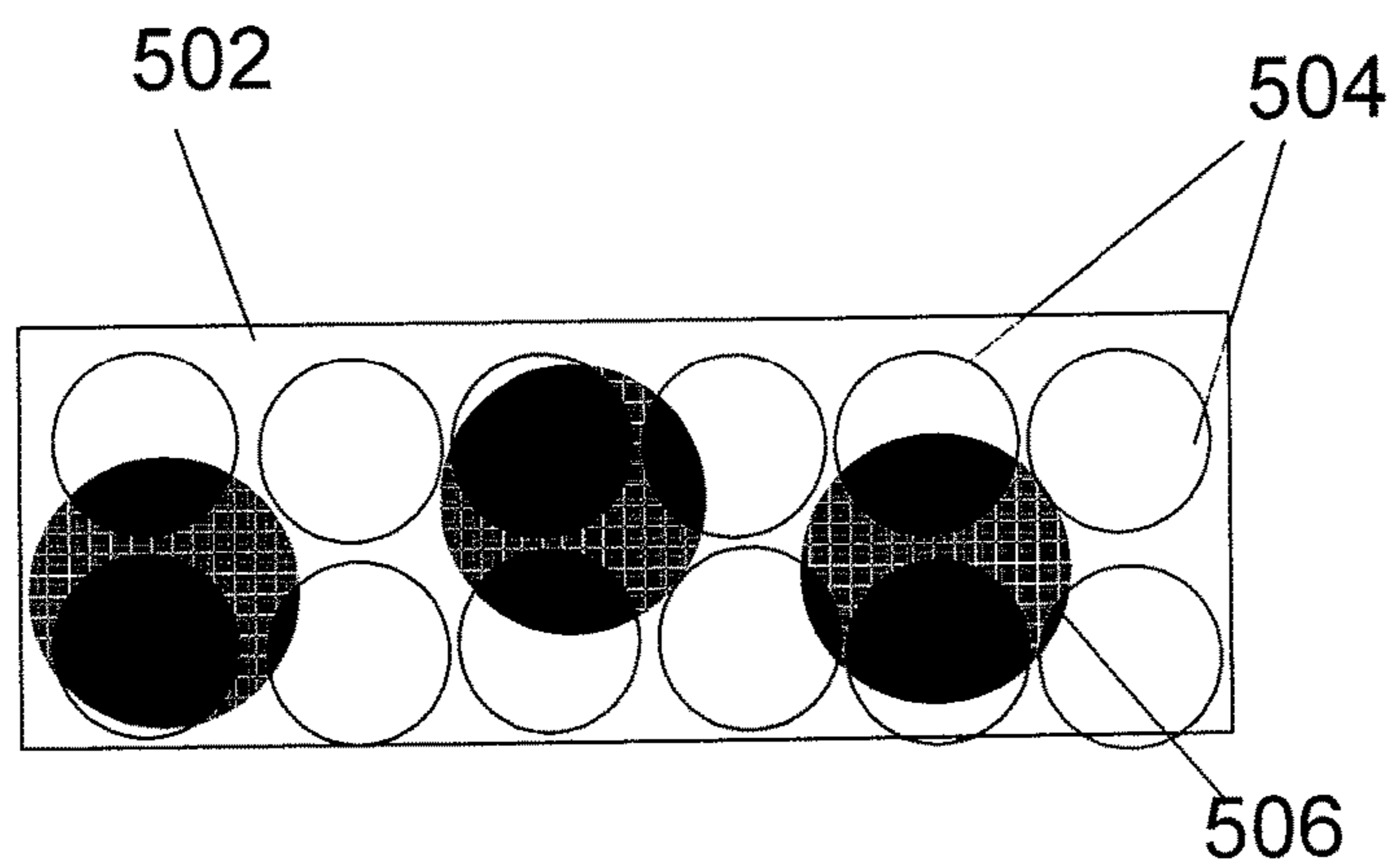
**FIG. 3**



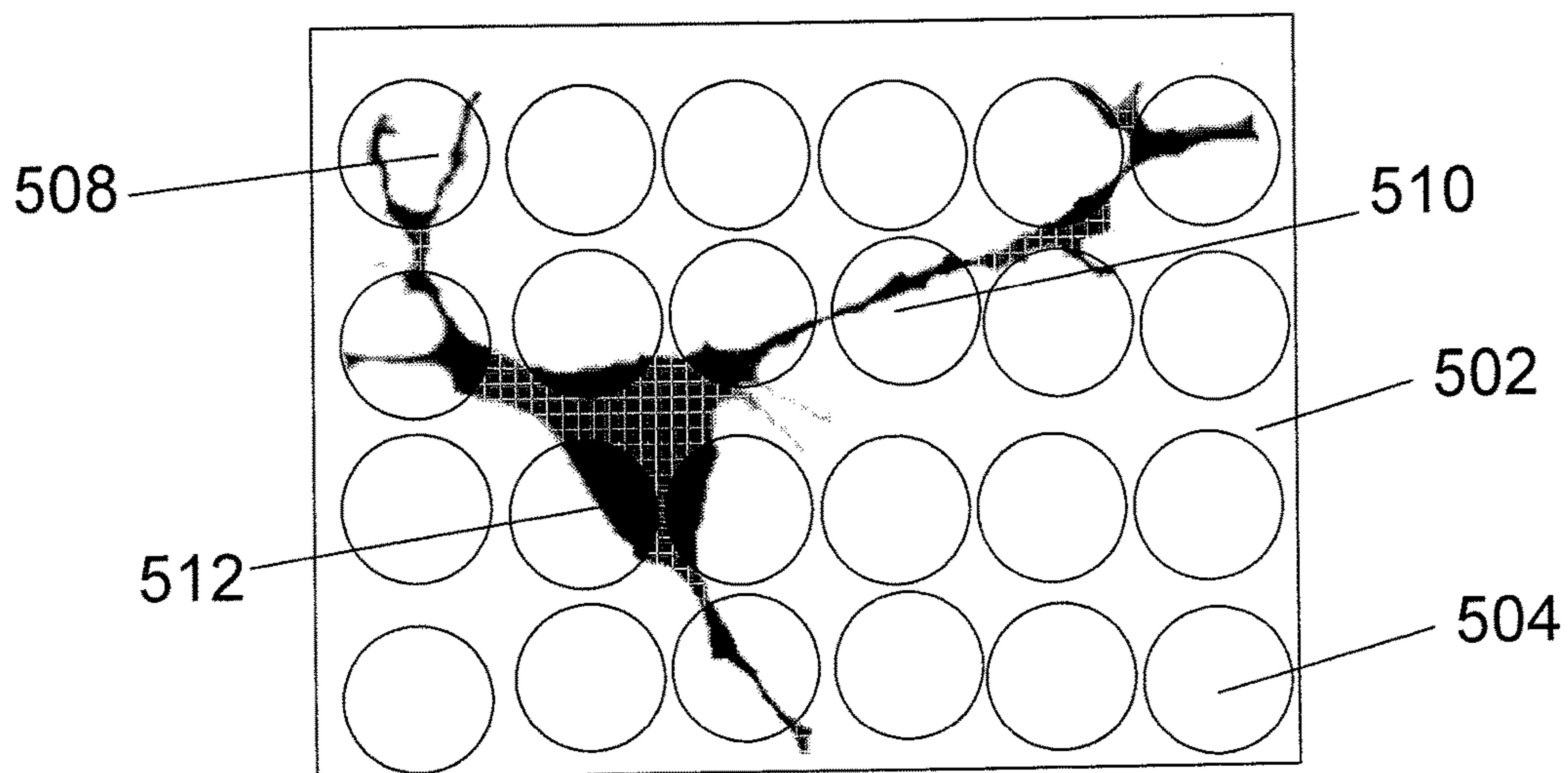
**FIG. 4A**



**FIG. 4B**



**FIG. 5A**



**FIG. 5B**

FIG. 6A

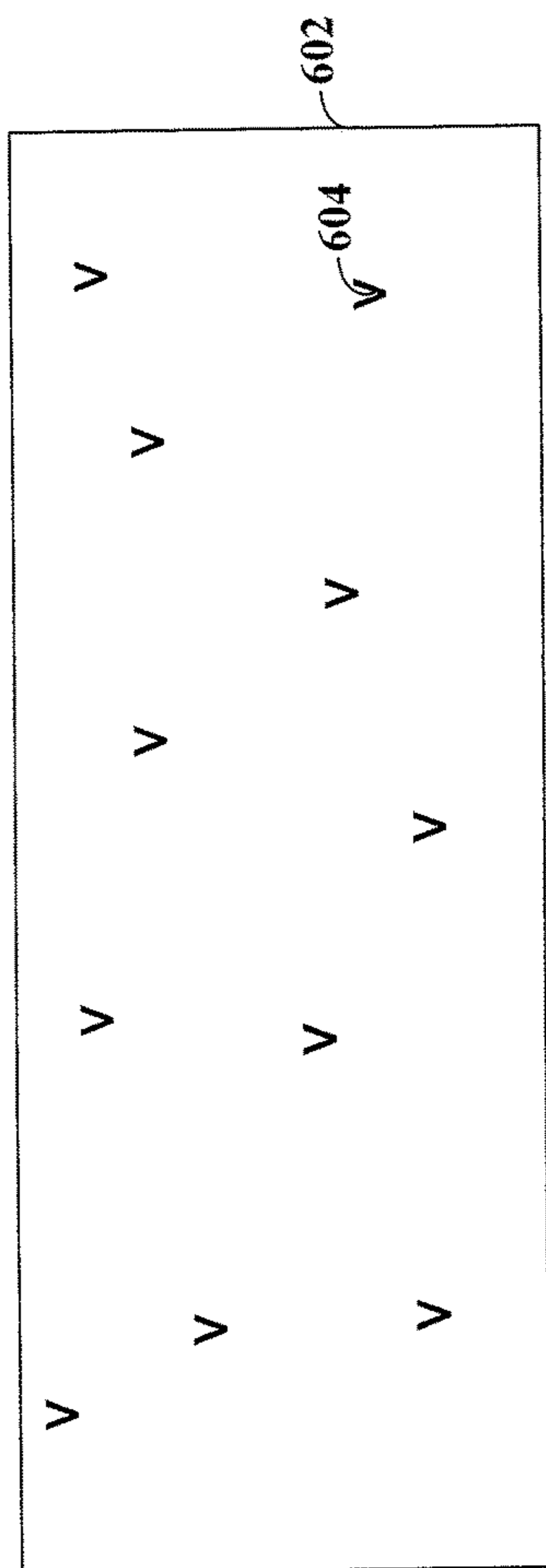
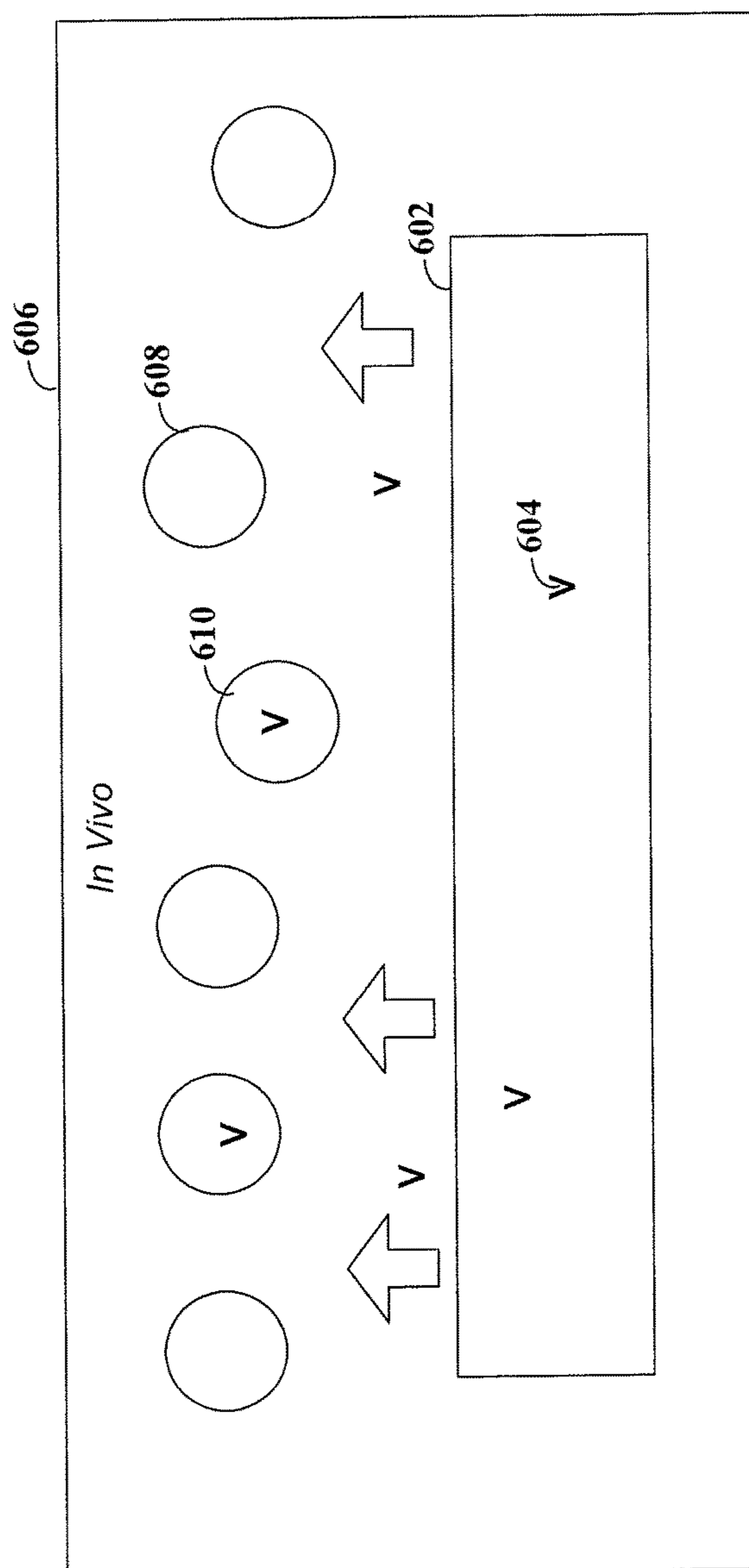


FIG. 6B



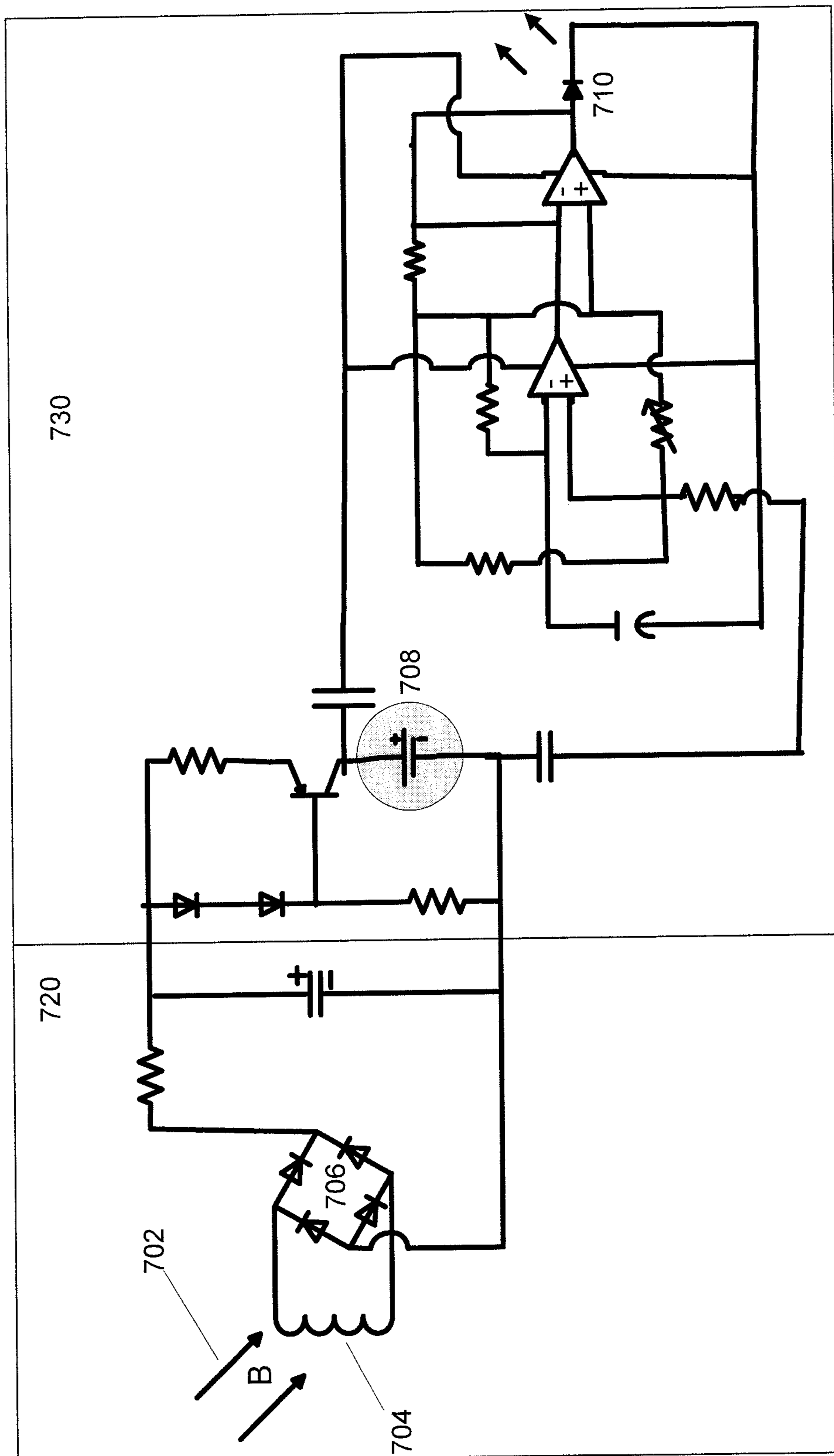


FIG. 7



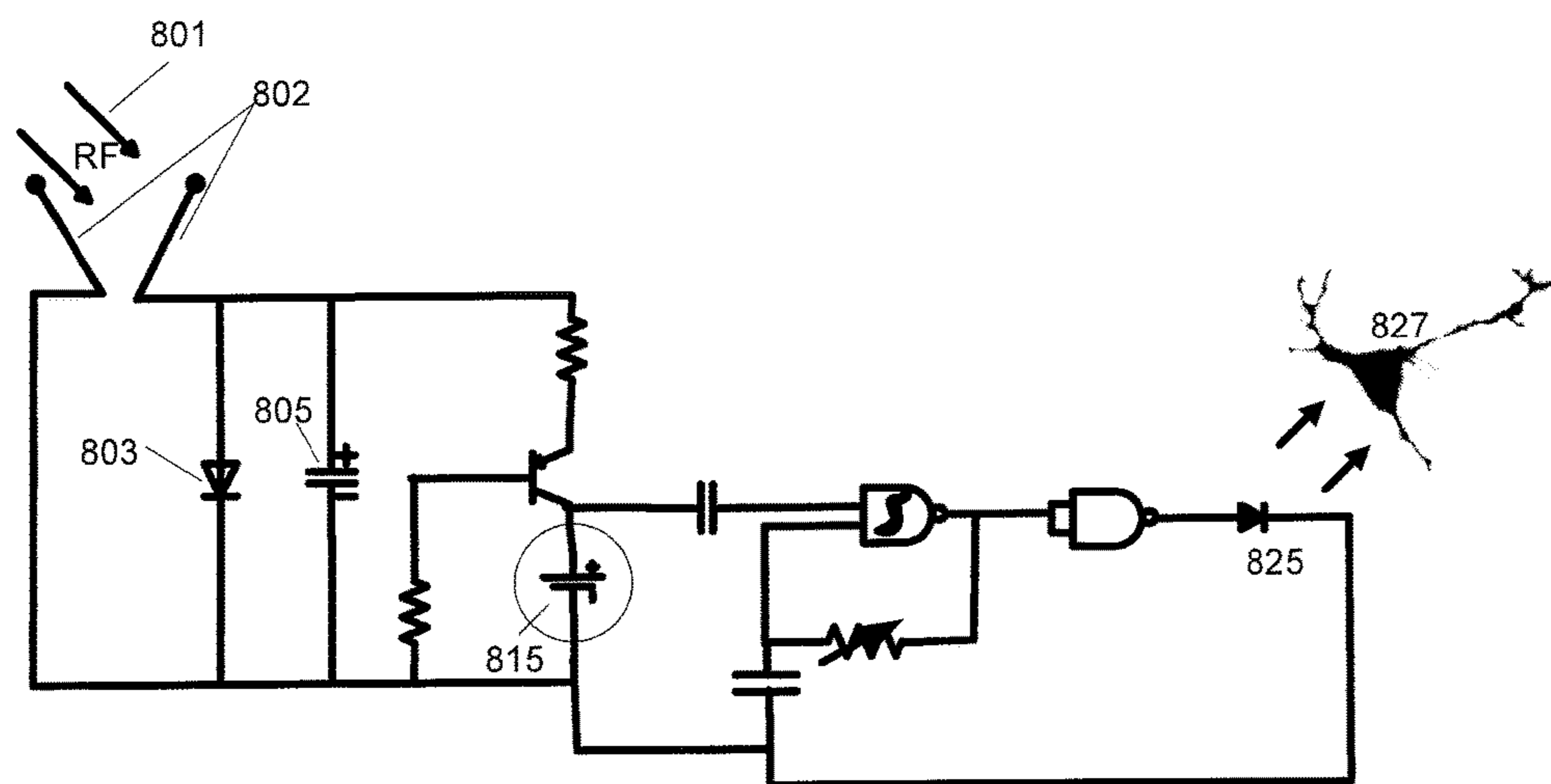


FIGURE 8A

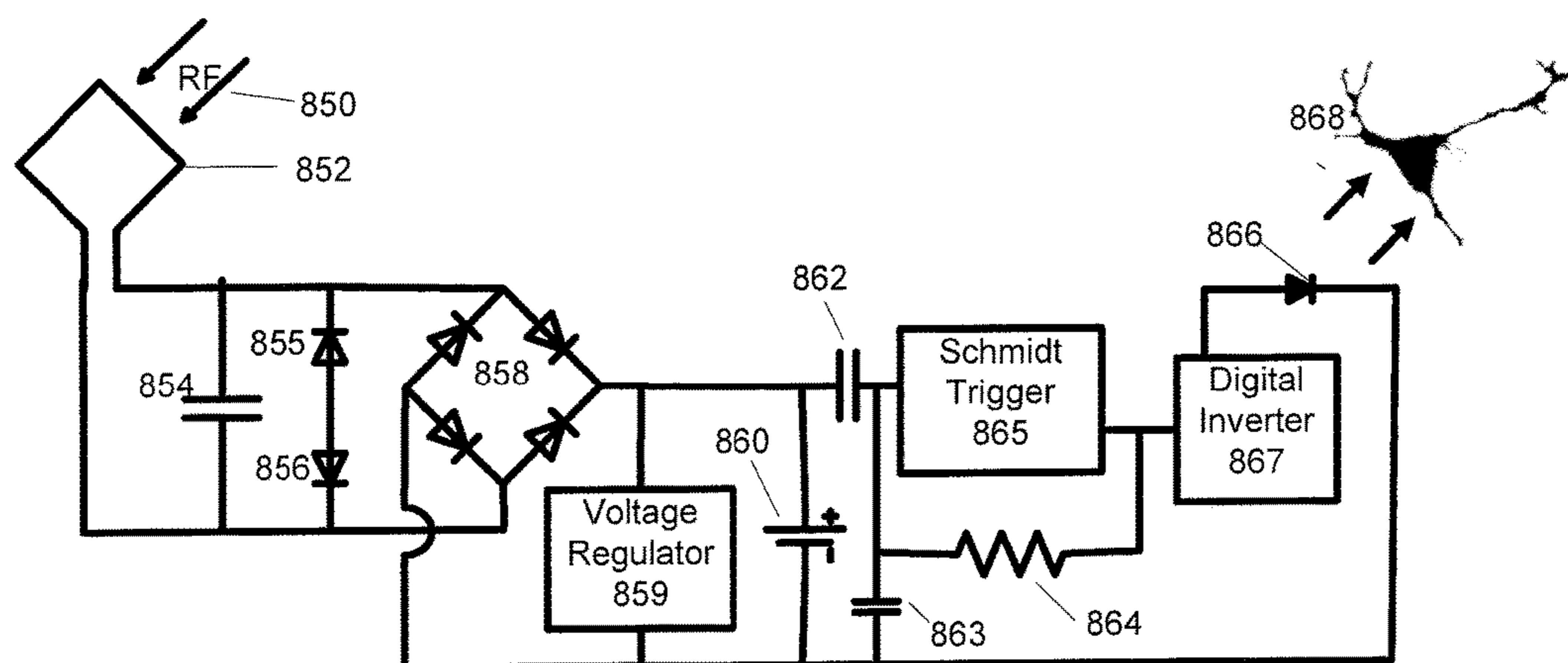


FIGURE 8B

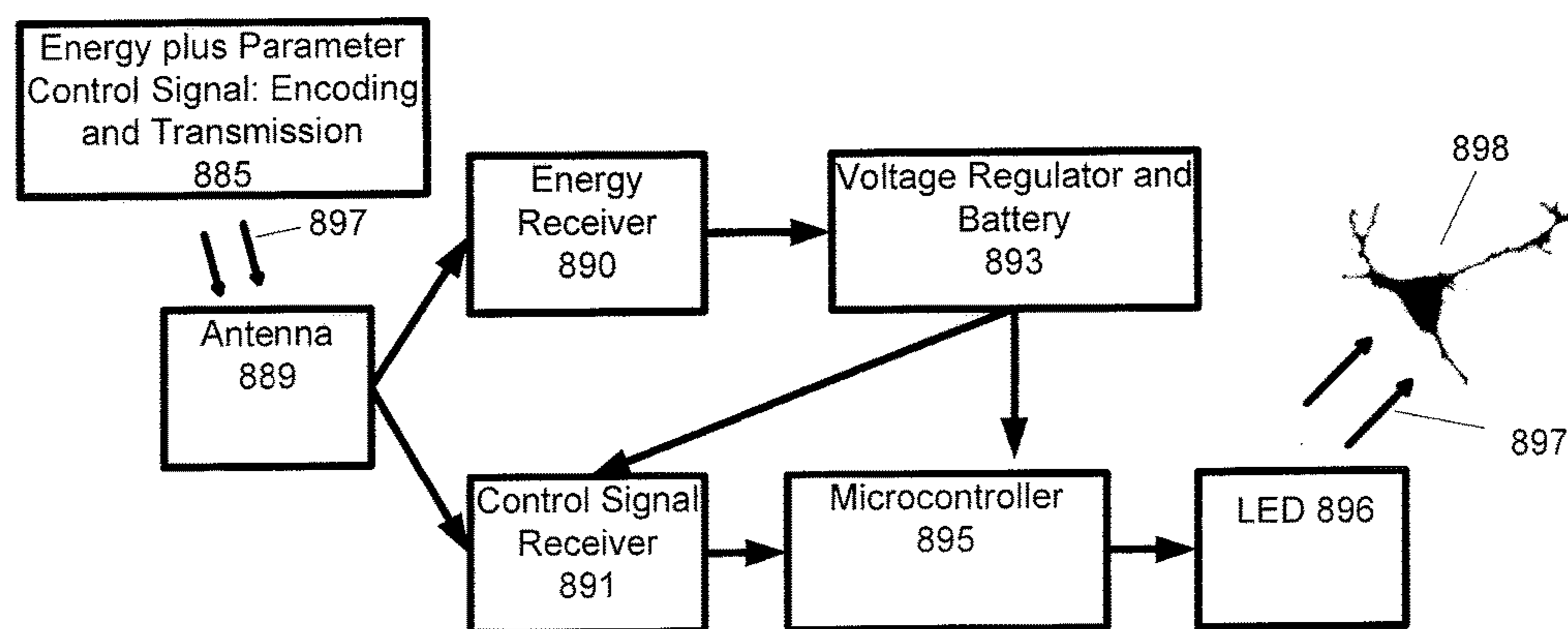
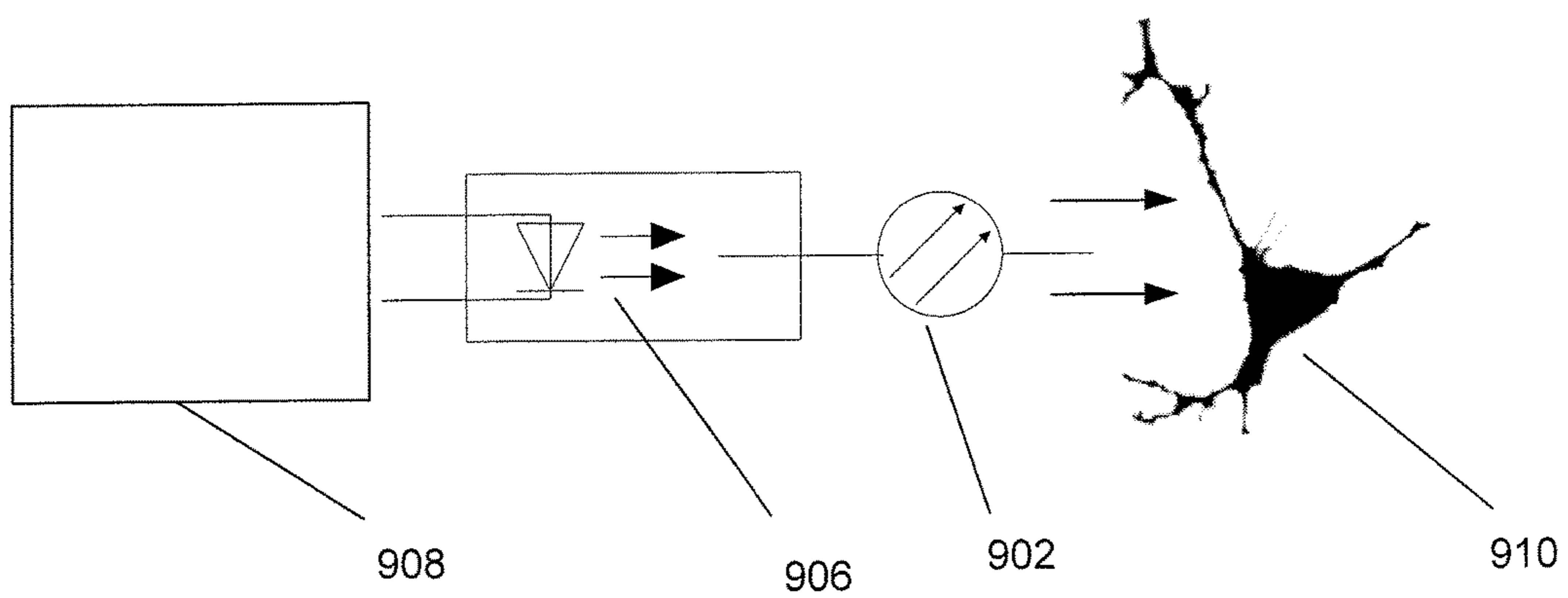
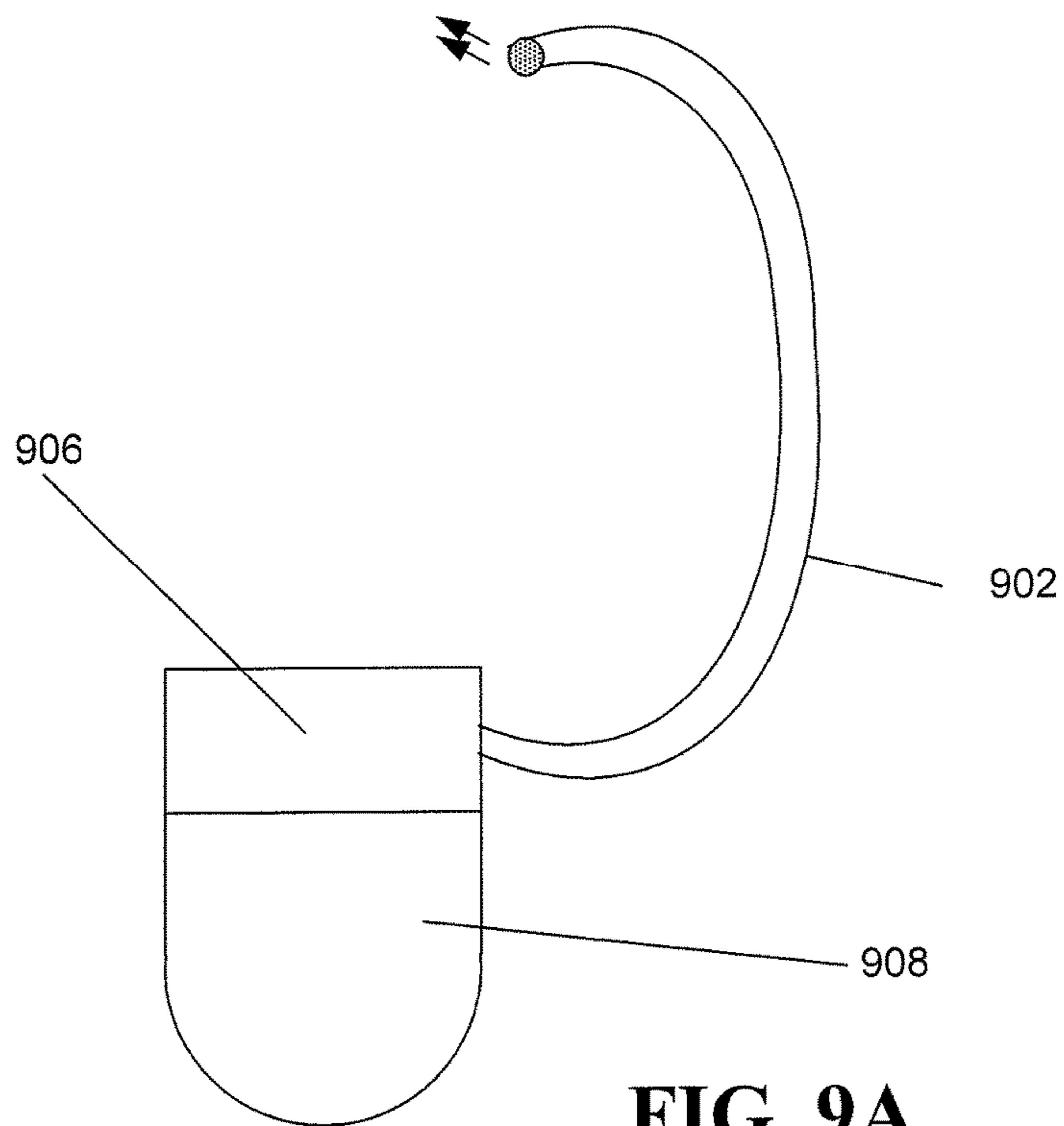
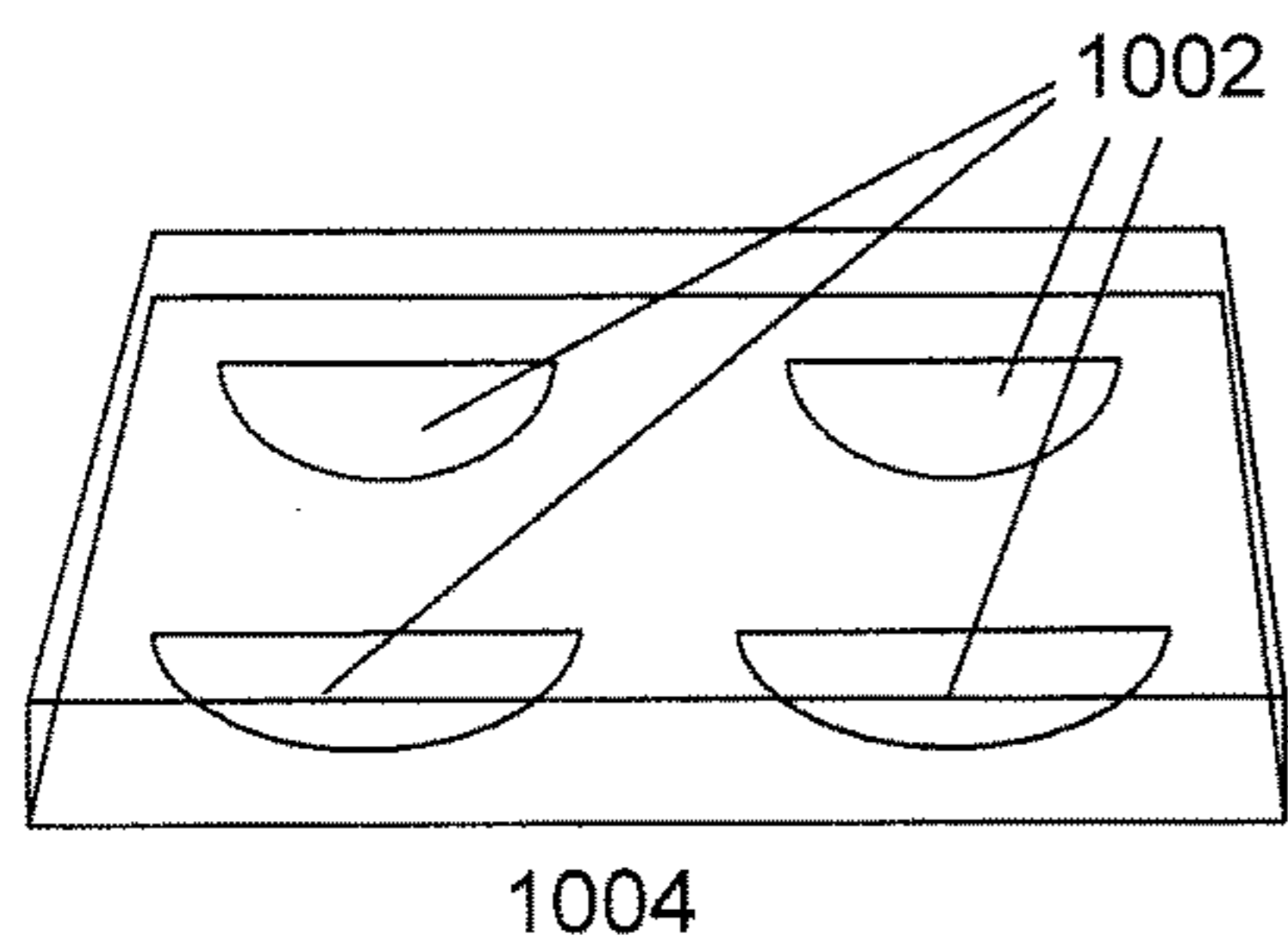
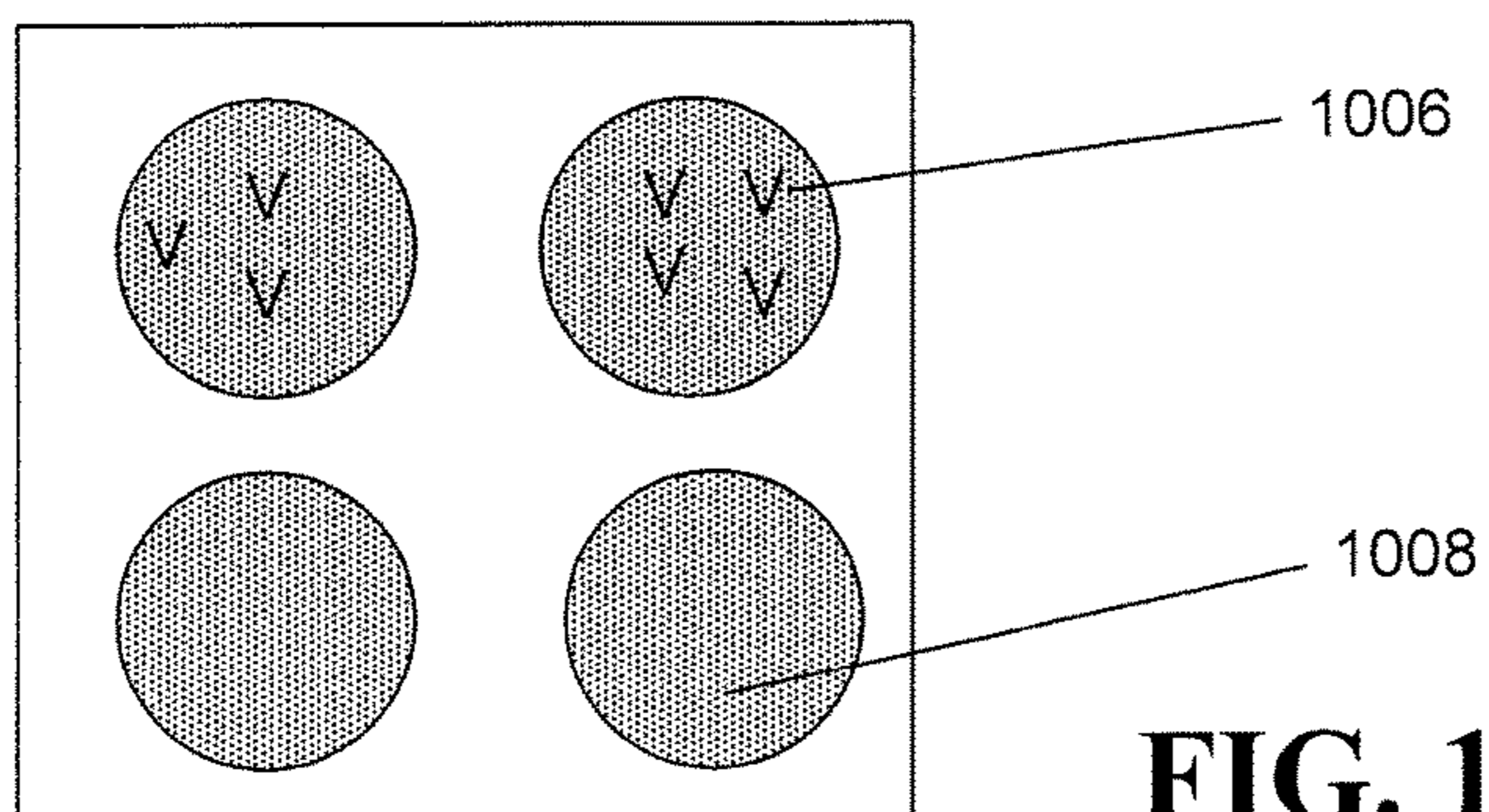


FIGURE 8C

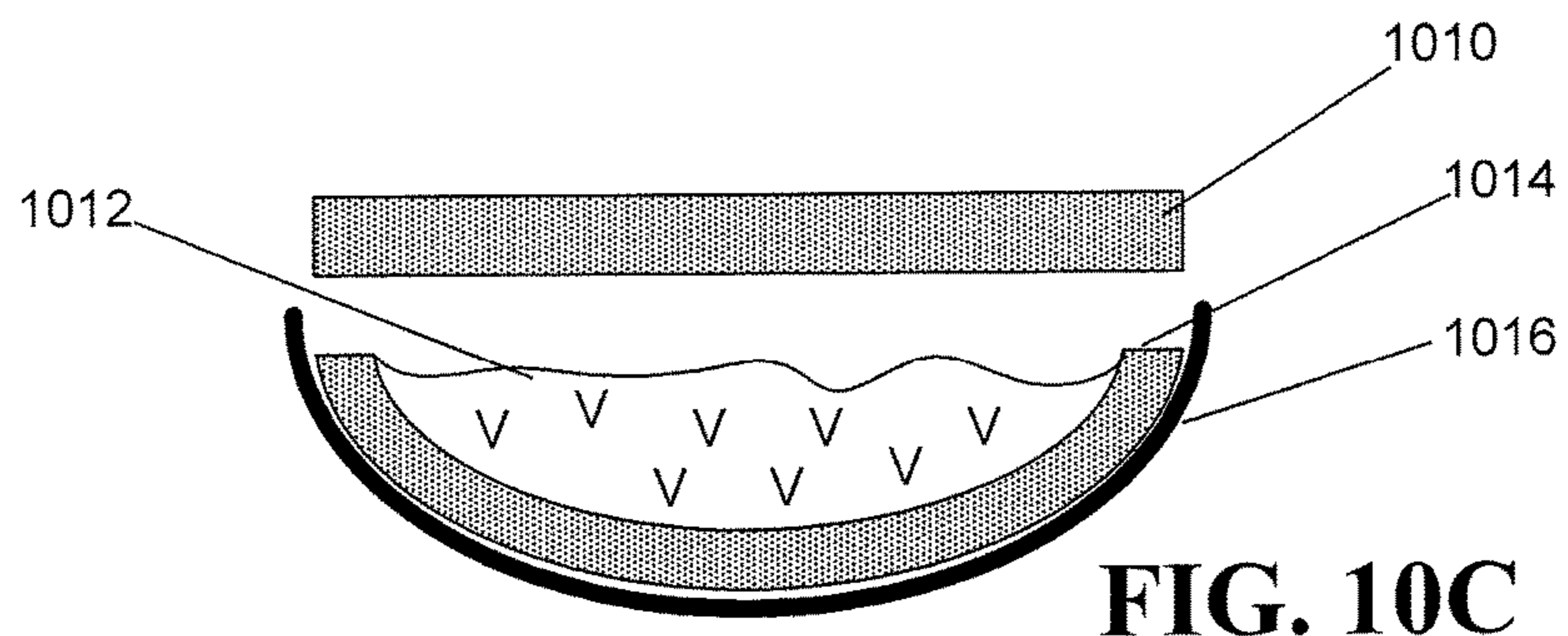




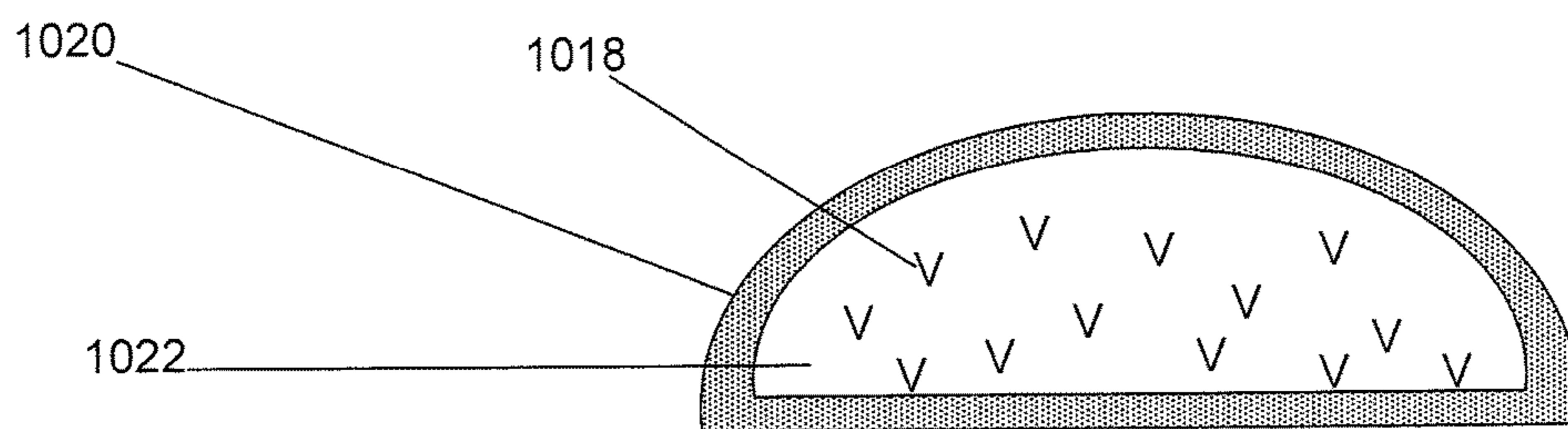
**FIG. 10A**



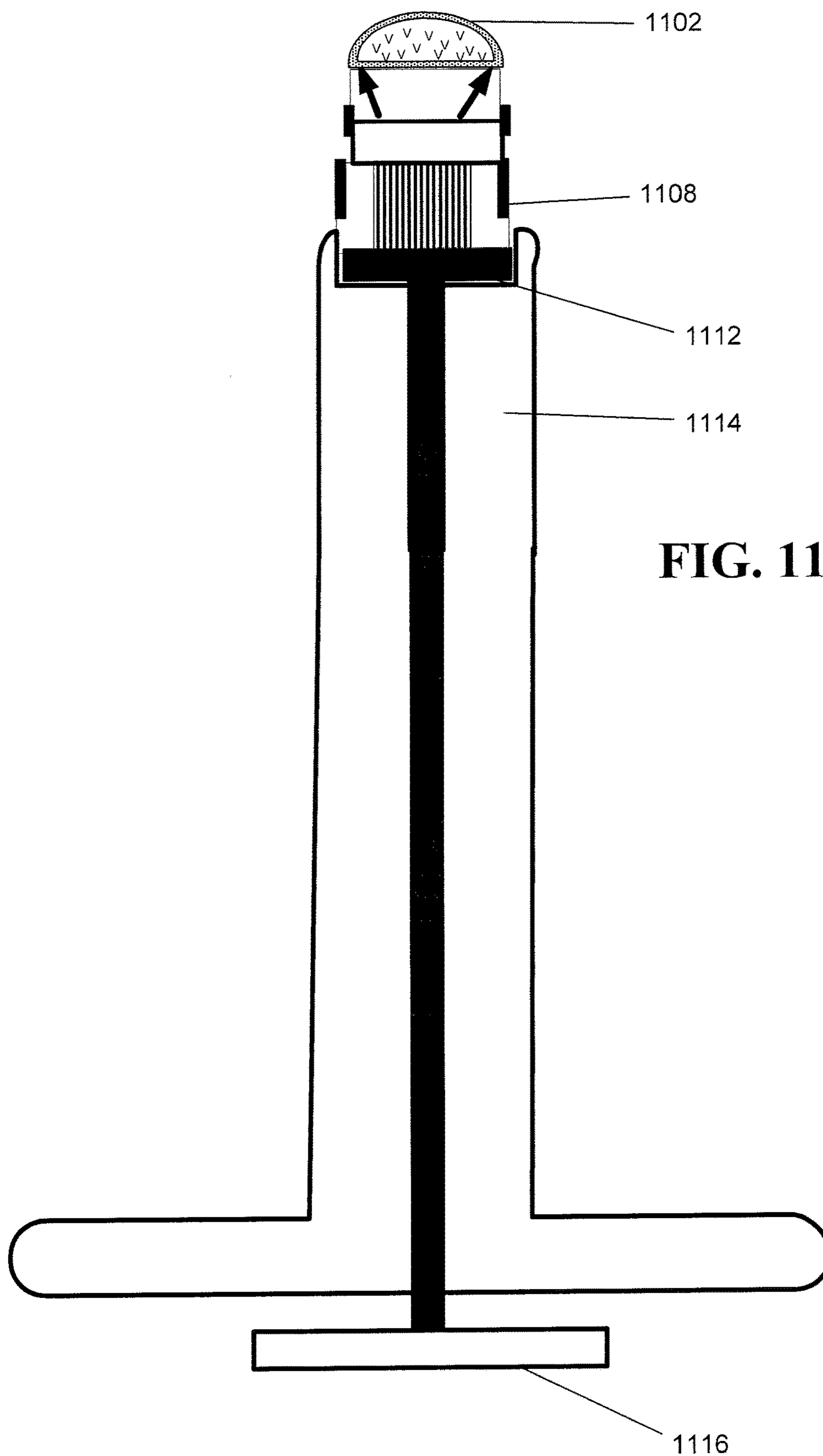
**FIG. 10B**

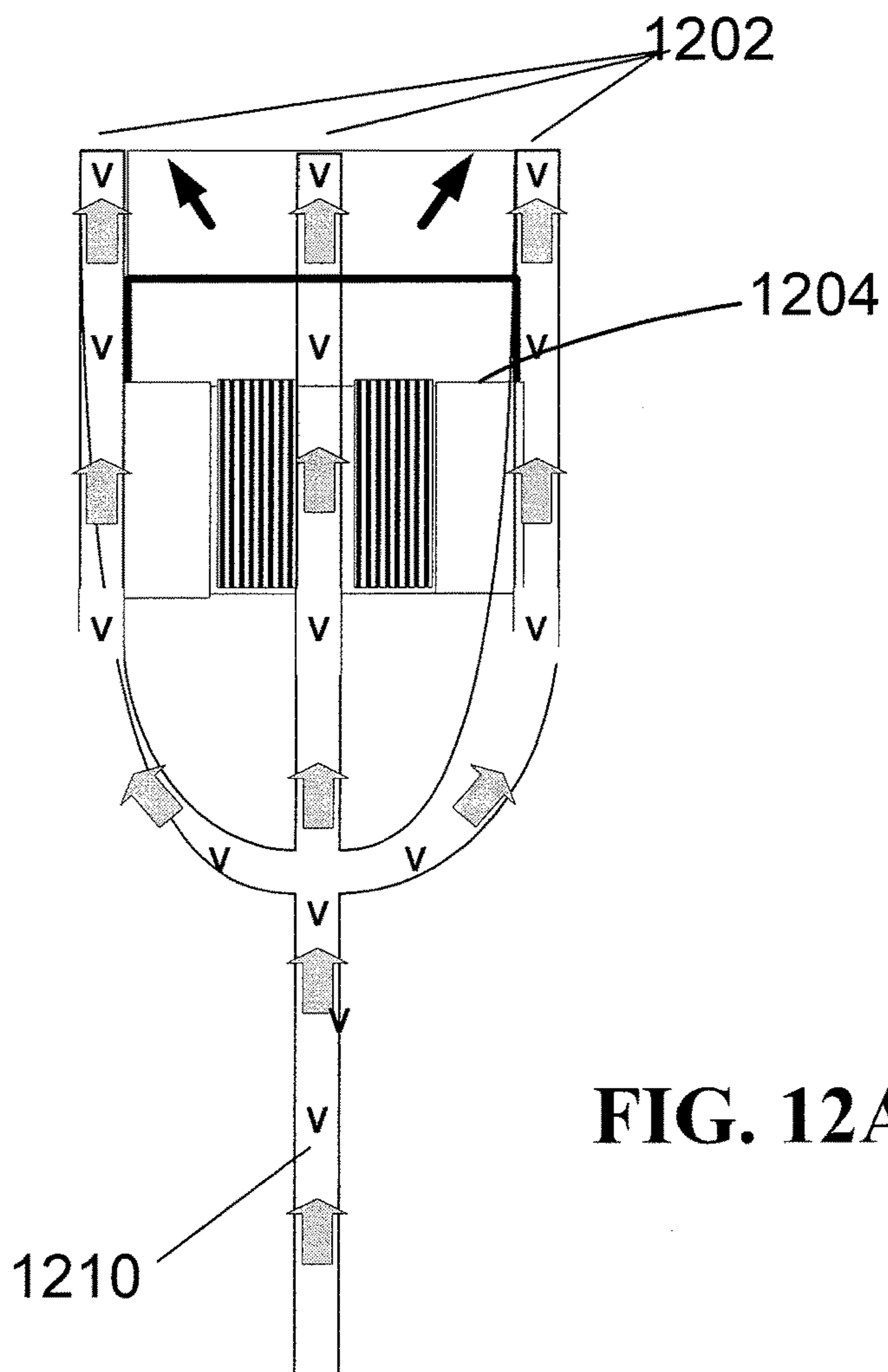


**FIG. 10C**

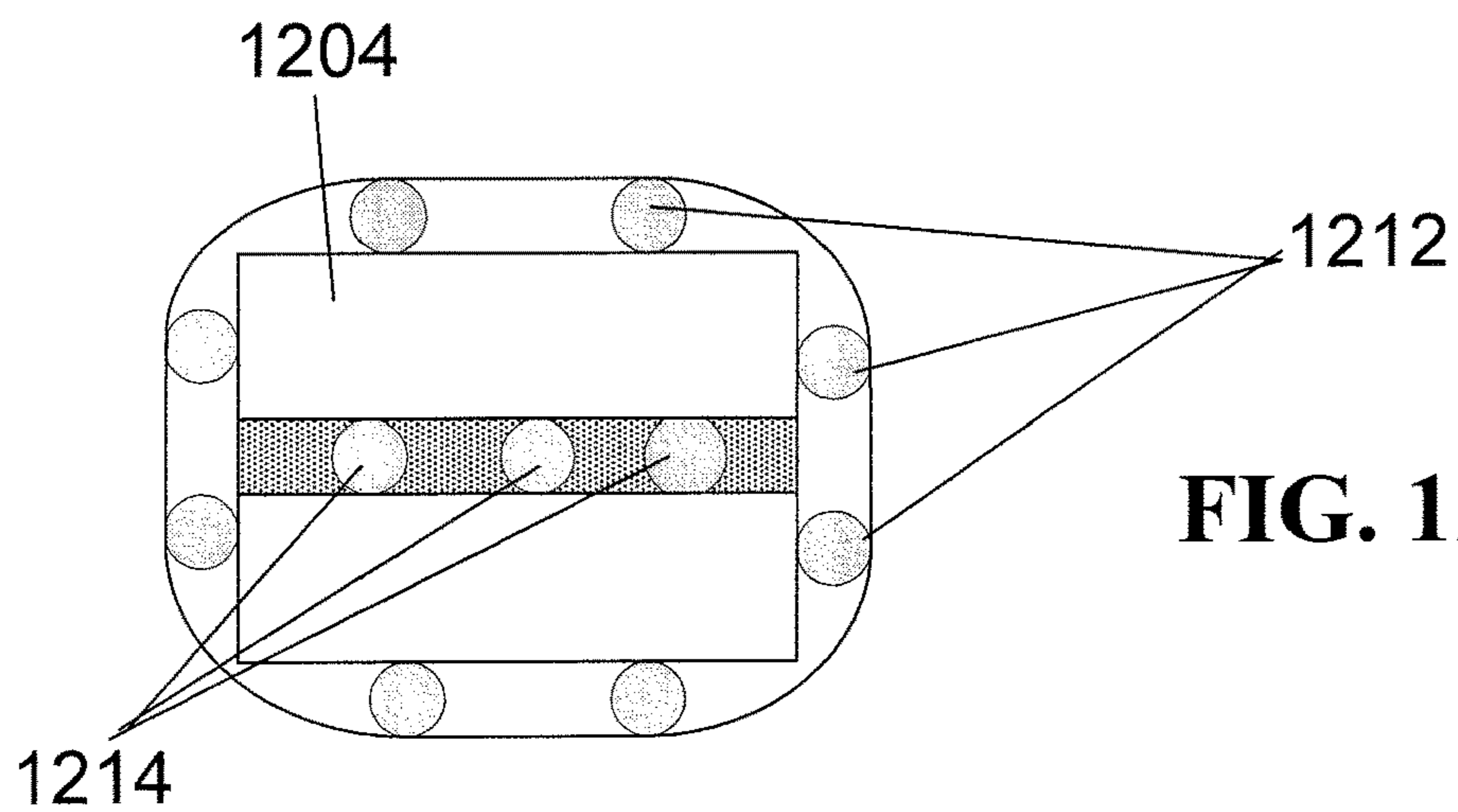


**FIG. 10D**





**FIG. 12A**



**FIG. 12B**

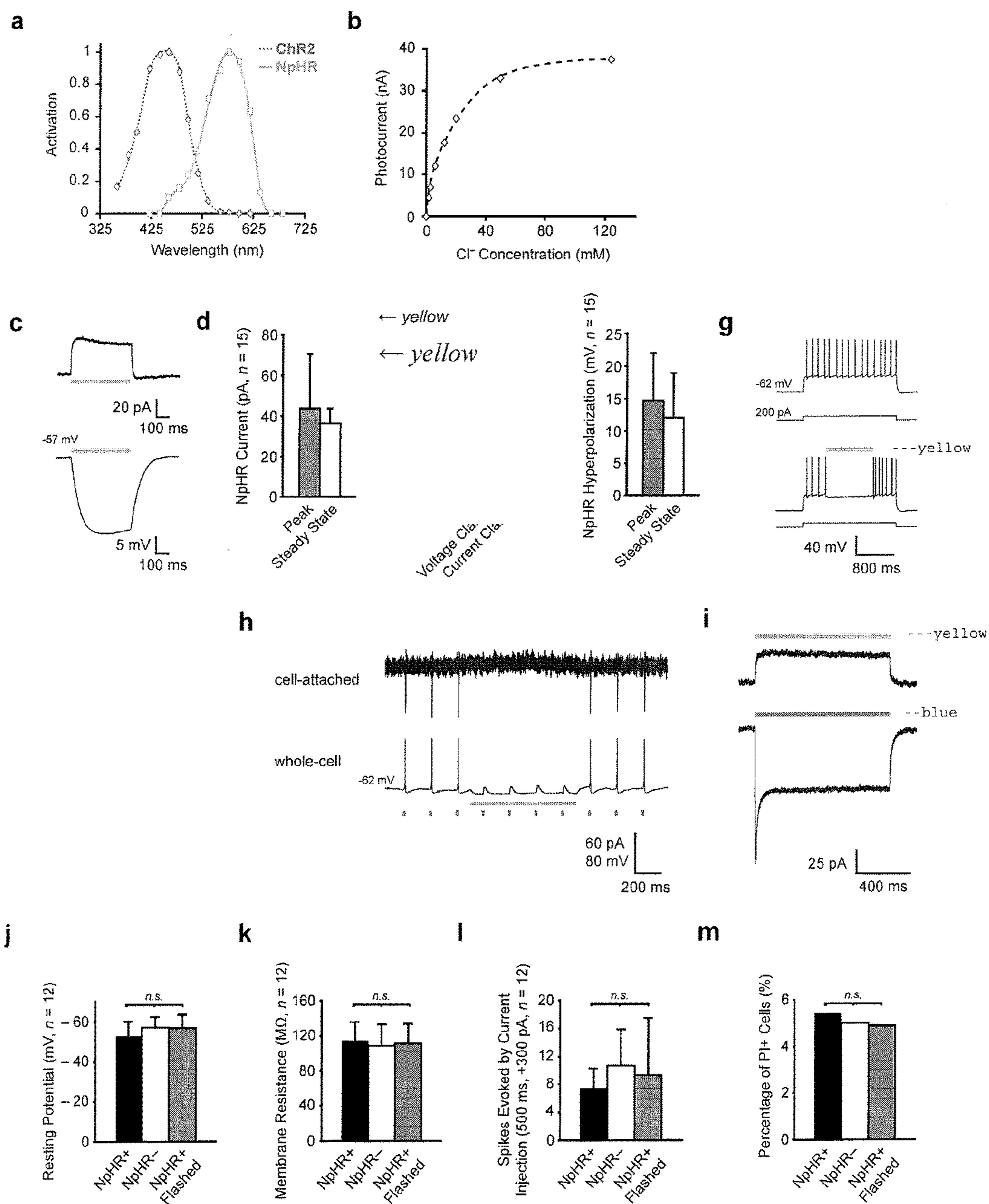


FIG. 13

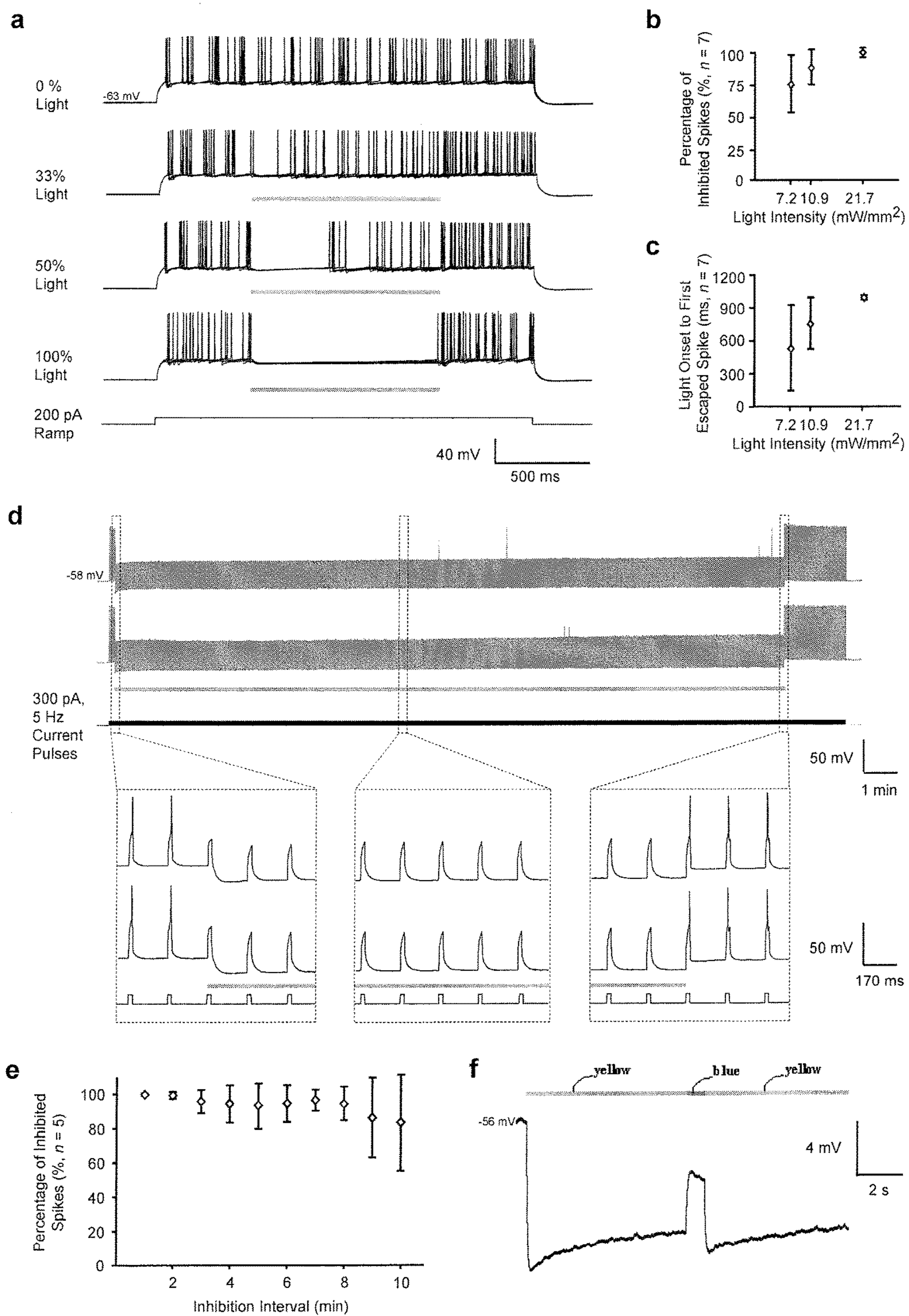
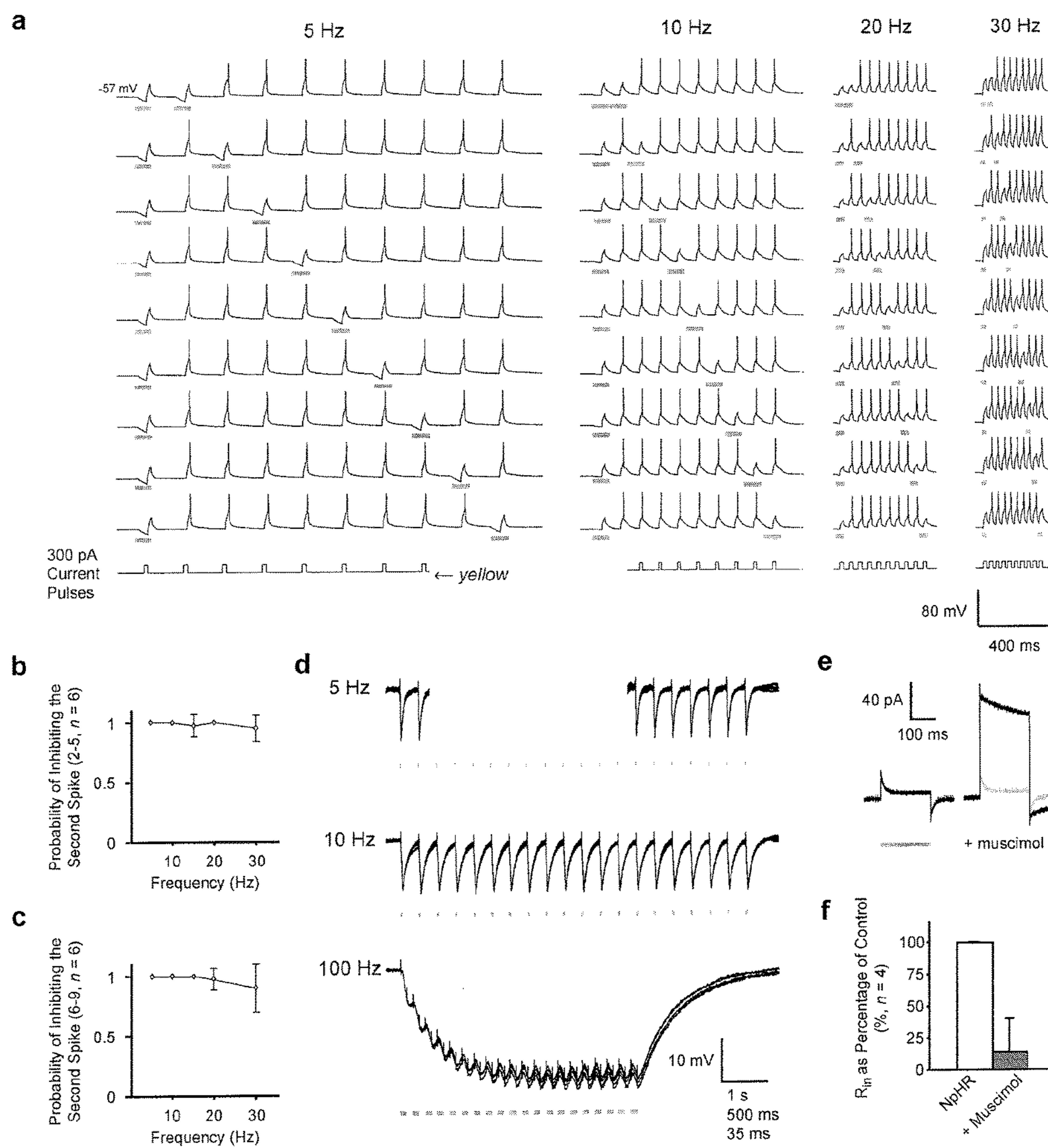


FIG. 14



**FIG. 15**



FIG. 16

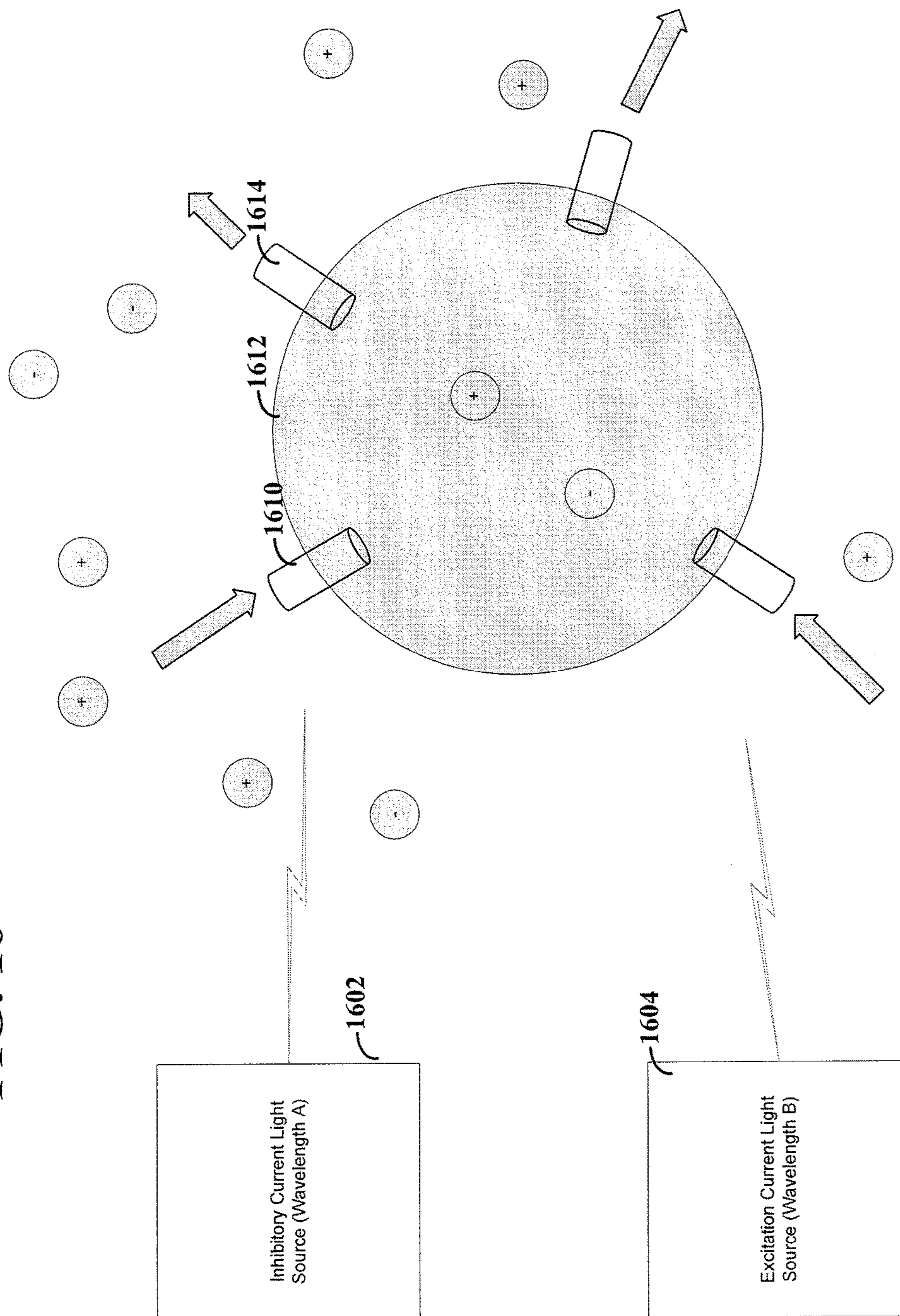
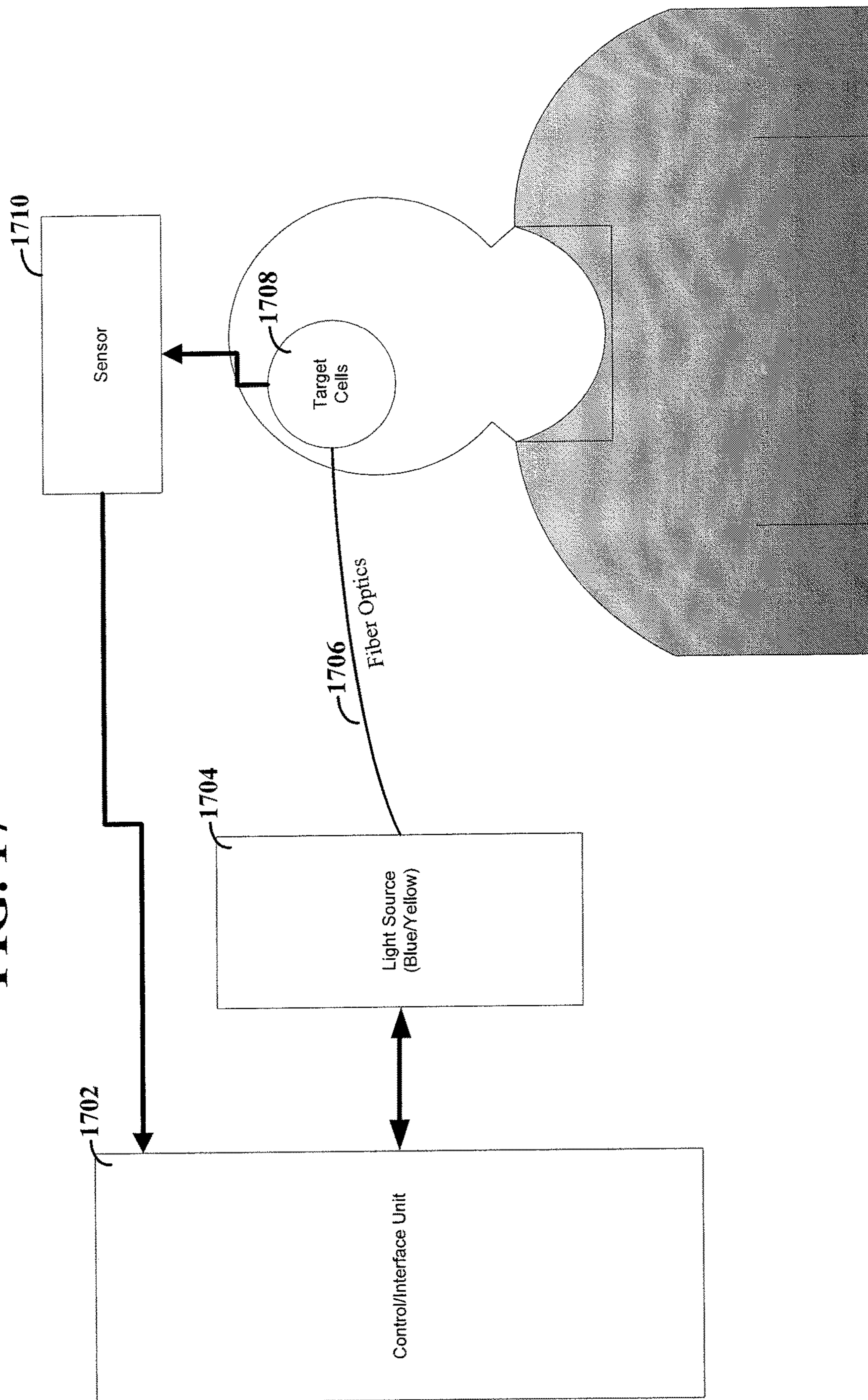
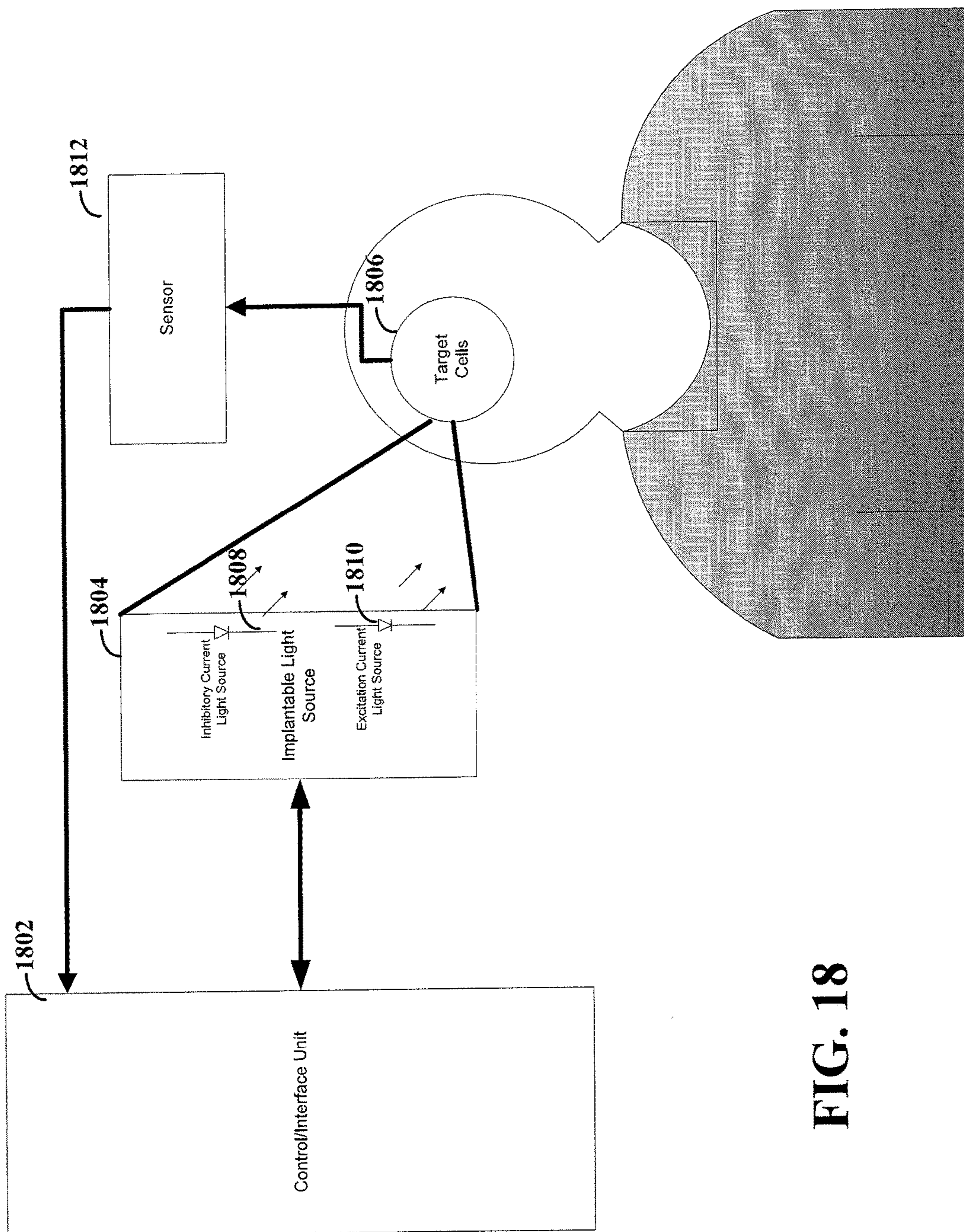
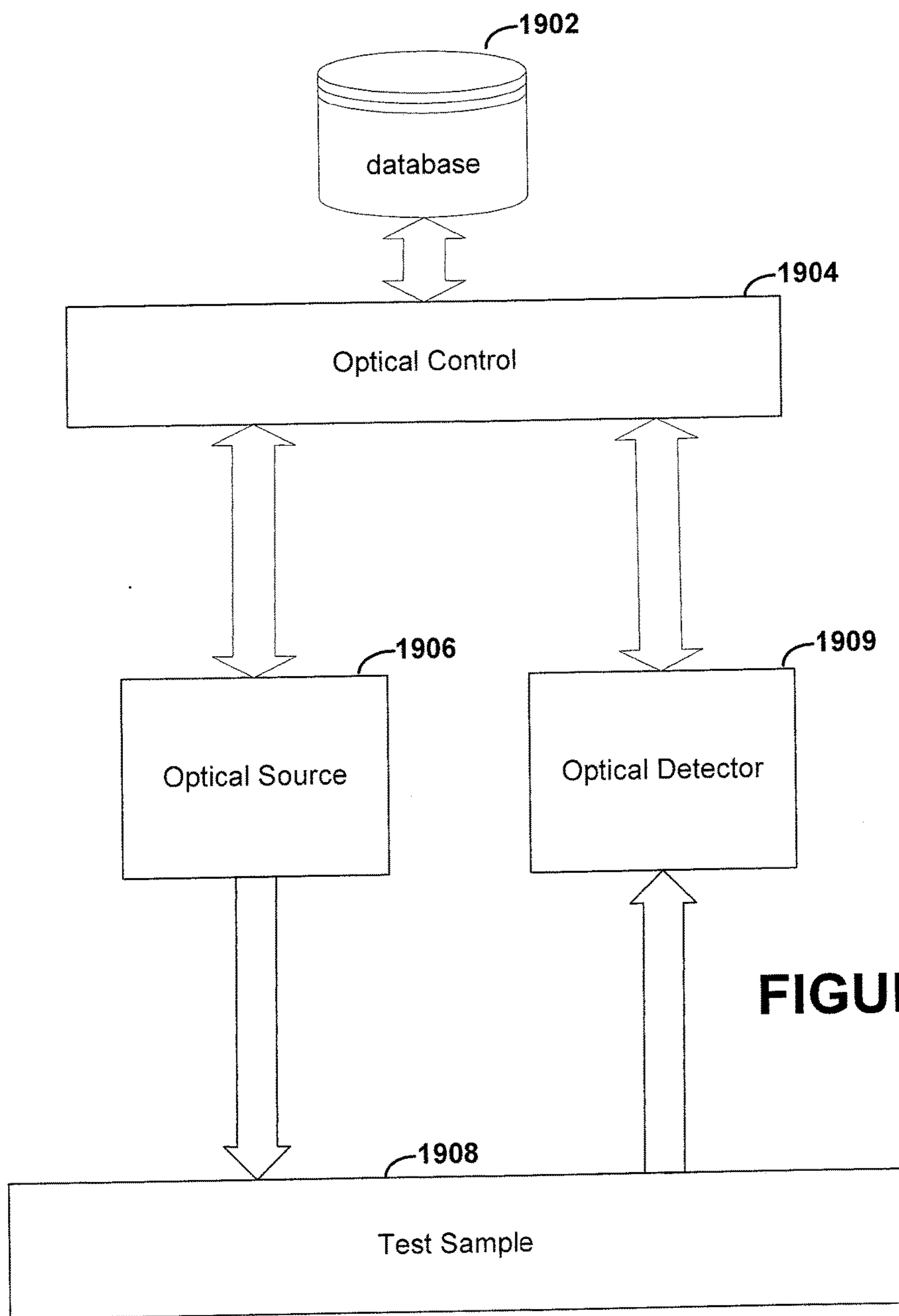


FIG. 17





**FIG. 18**



**FIGURE 19A**

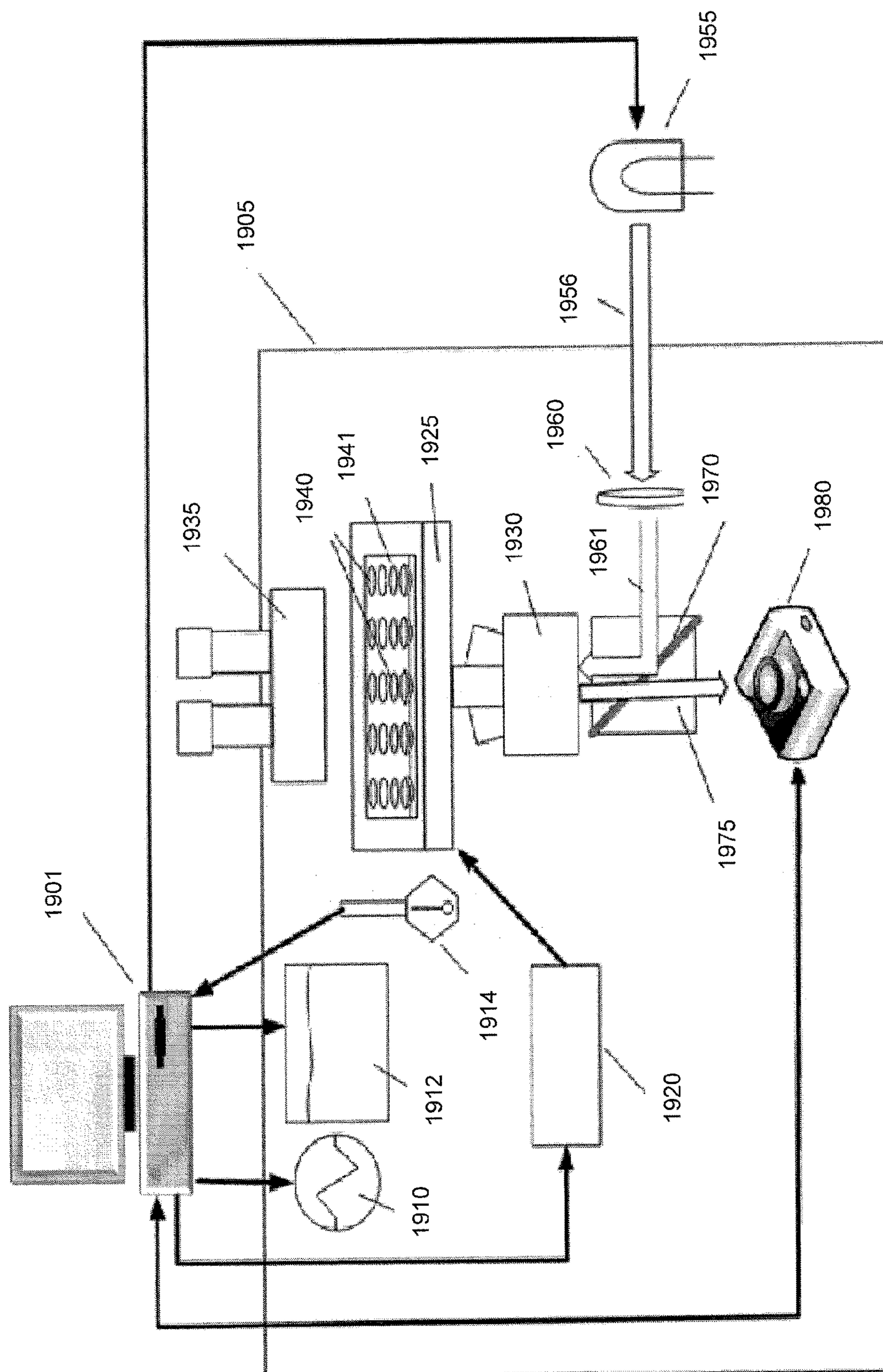


Figure 19B

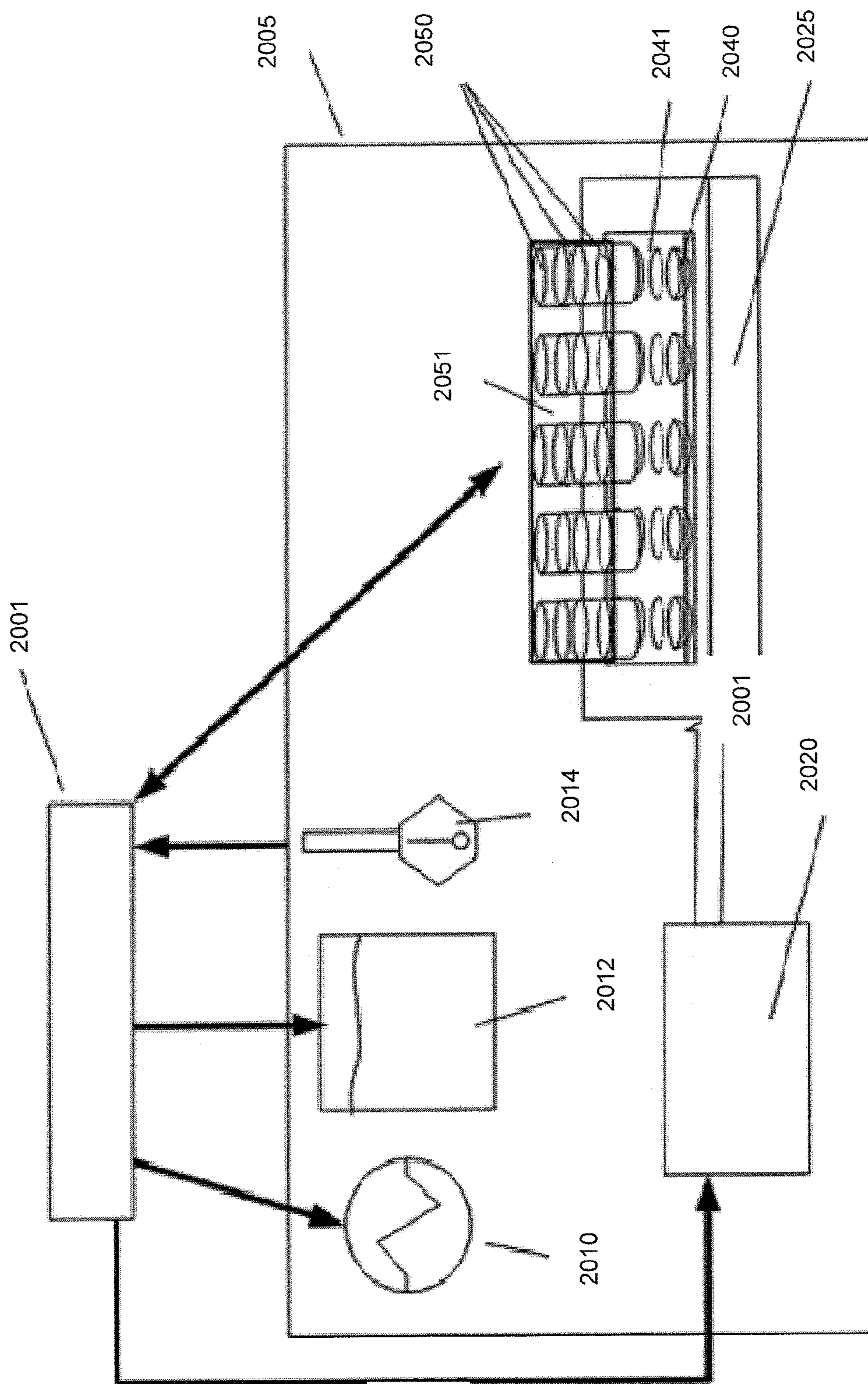
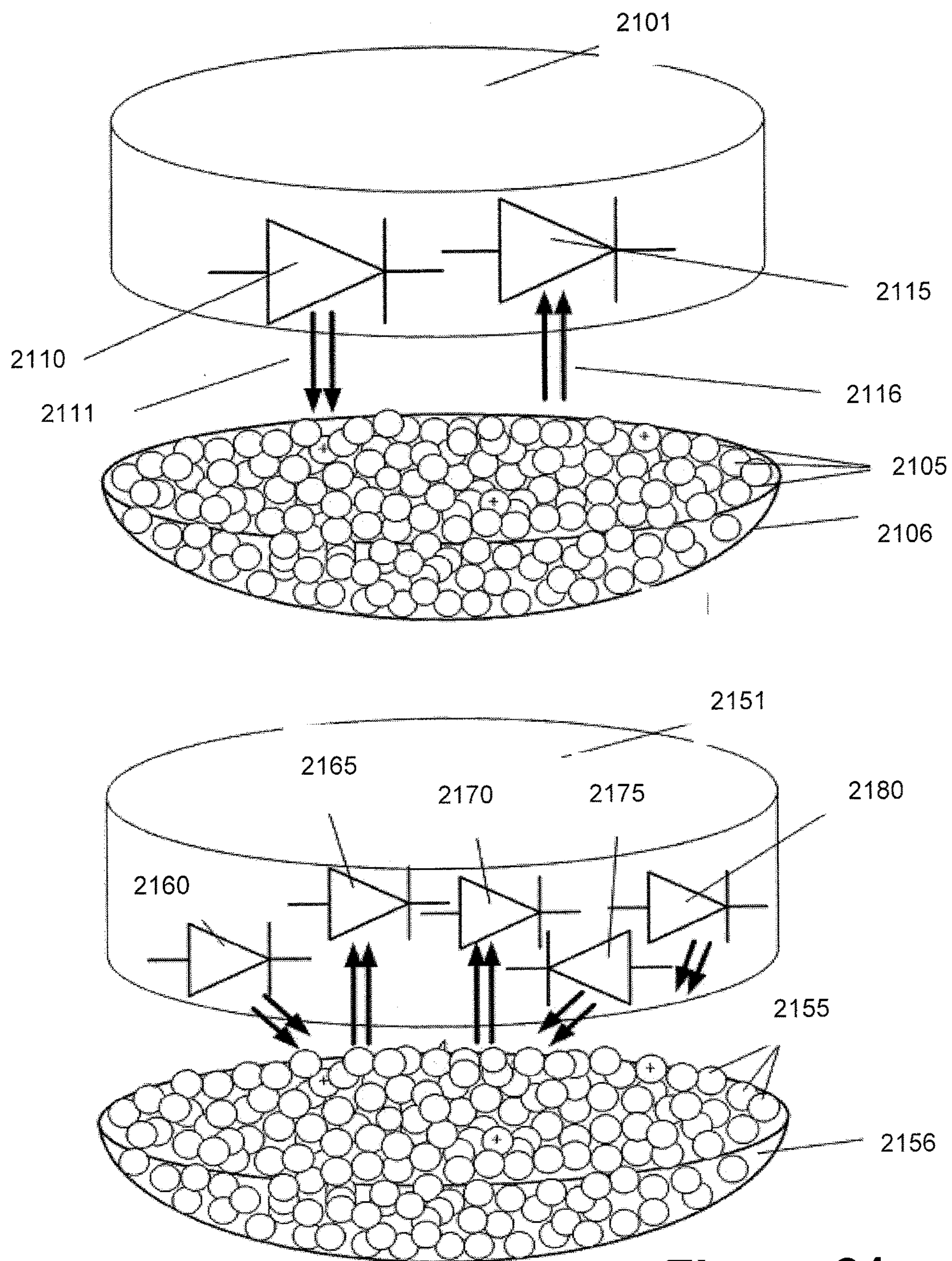


Figure 20



**Figure 21**

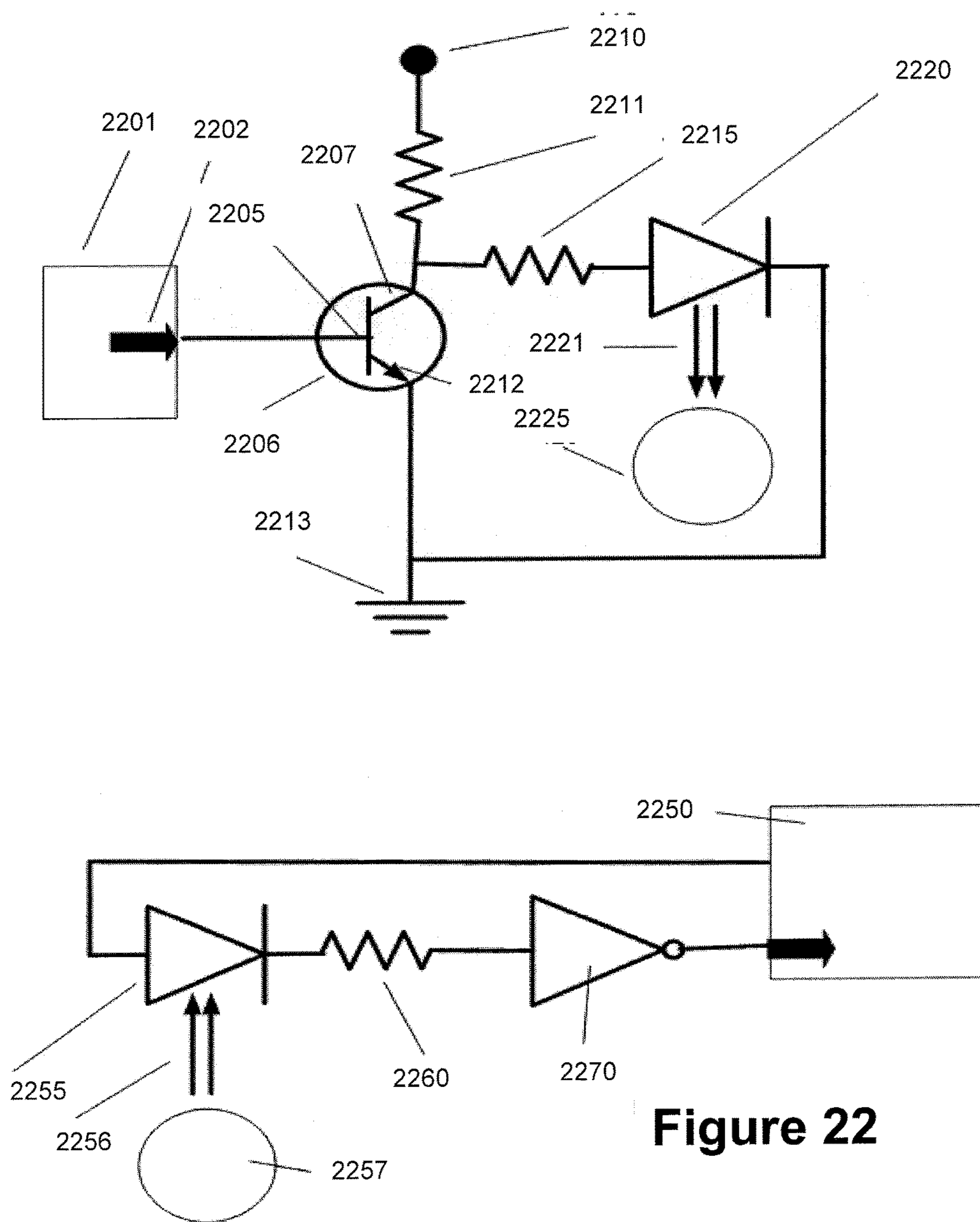


Figure 22



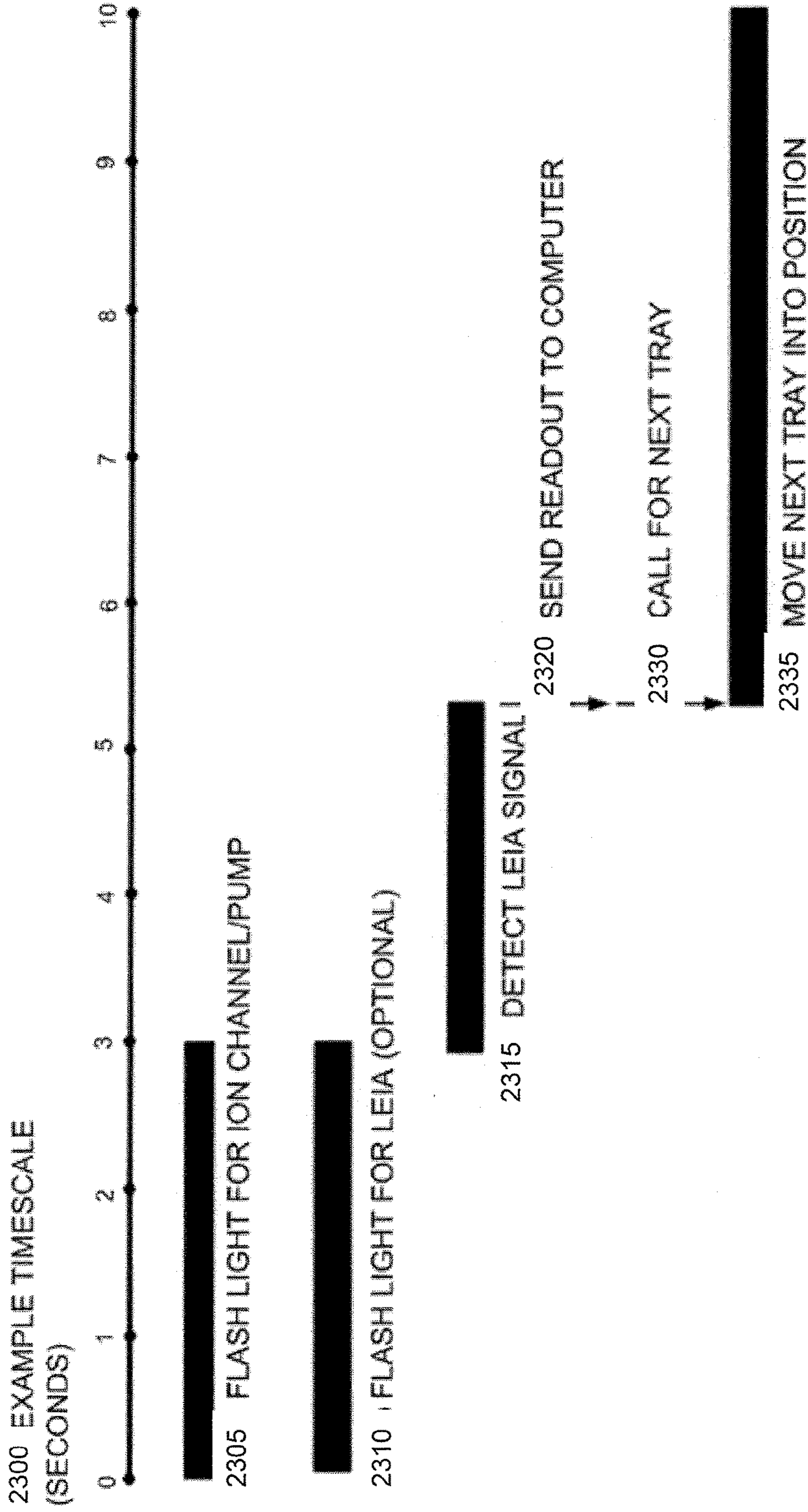


Figure 23

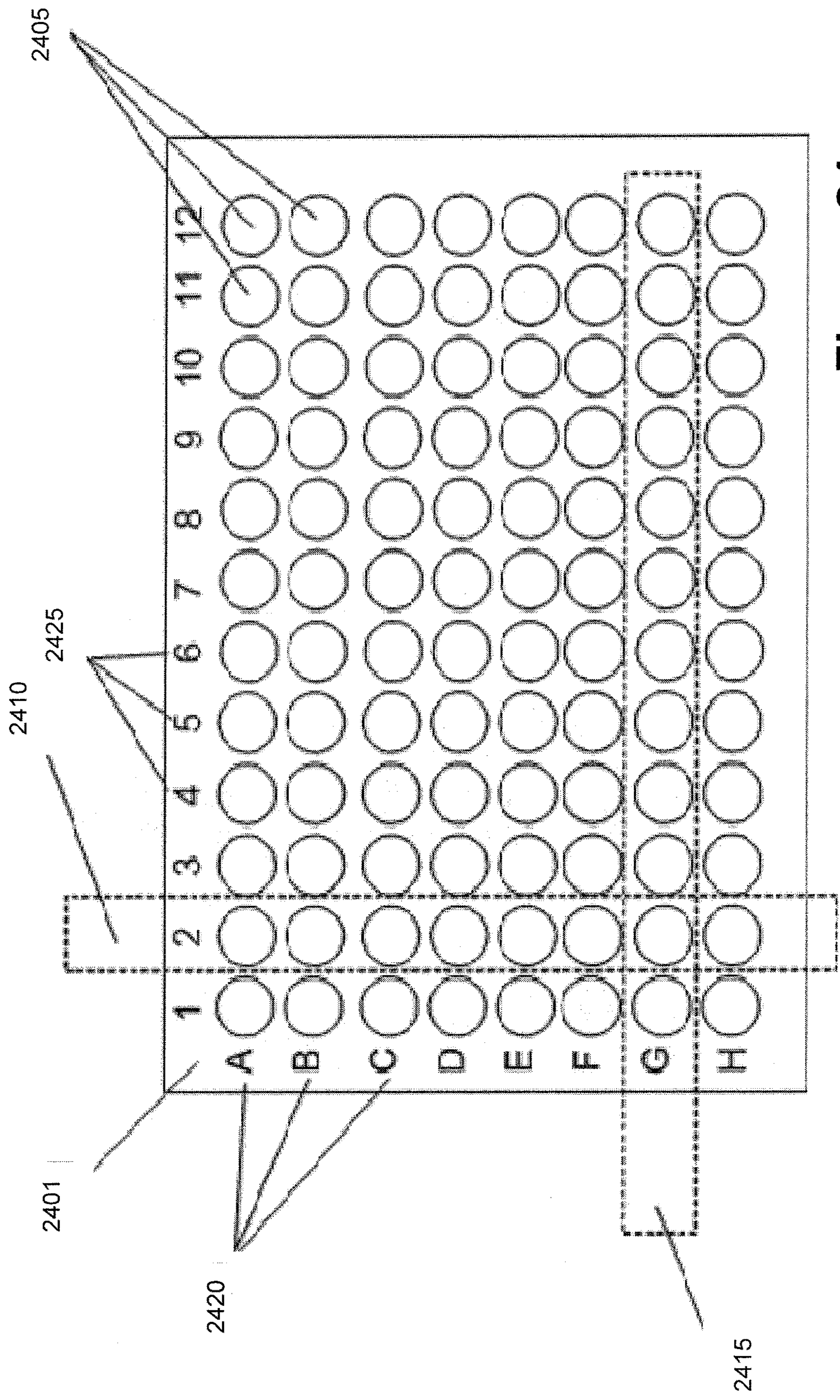


Figure 24

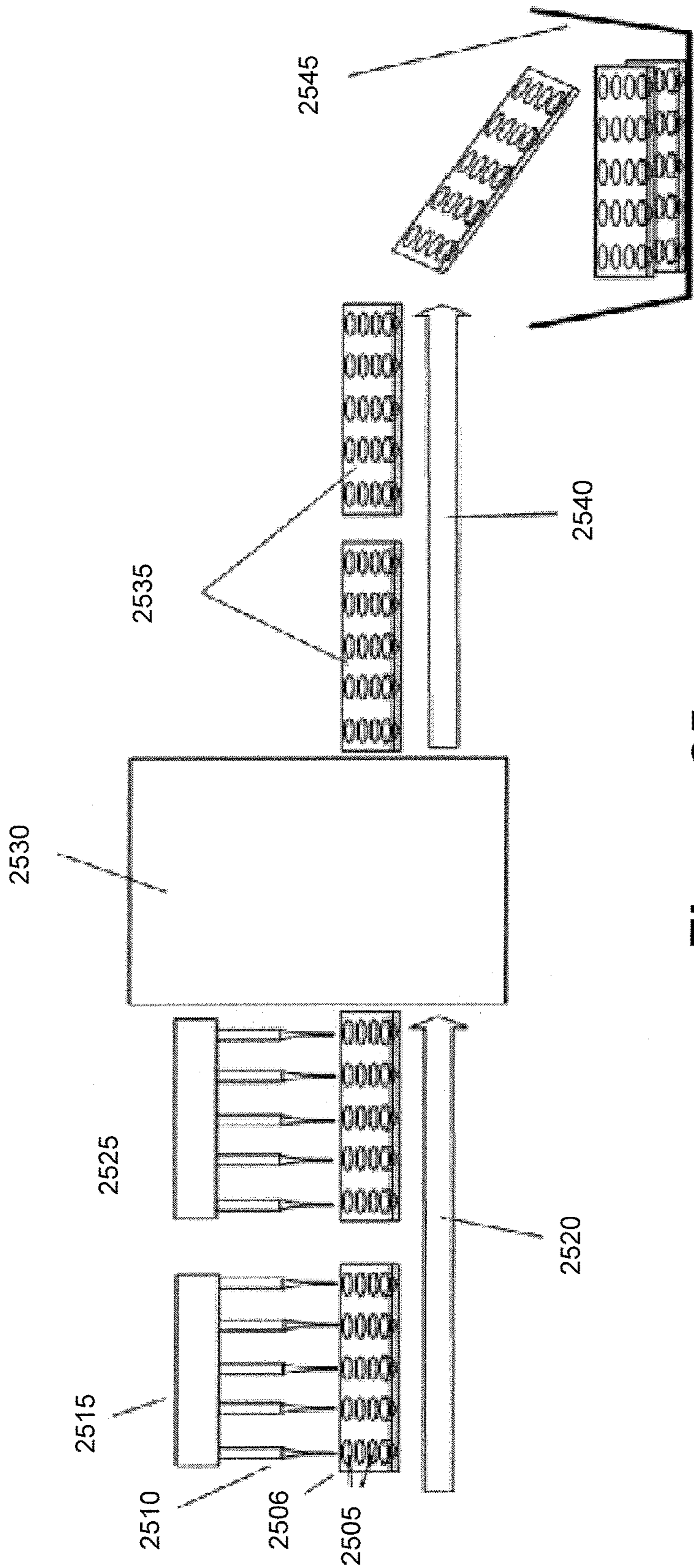


Figure 25

## SYSTEM FOR OPTICAL STIMULATION OF TARGET CELLS

### RELATED PATENT DOCUMENTS

**[0001]** To the extent that this patent document is the basis for U.S.A. national entry, this patent document claims benefit under 35 U.S. § 119(e) of U.S. Provisional Application Ser. No. 60/904,303 filed on Mar. 1, 2007 (STFD. 165P1); Ser. No. 60/955,116, filed Aug. 10, 2007 (STFD. 167P1); and Ser. No. 60/879,669 filed on Jan. 10, 2007 (STFD.199P1), and further claims benefit as a continuation-in-part under 35 U.S. § 120 of U.S. Nonprovisional application Ser. No. 11/651,422, filed Jan. 9, 2007 (STFD. 150PA). Each of these patent documents is incorporated by reference in its entirety.

### FIELD OF THE INVENTION

**[0002]** The present invention relates generally to systems and approaches for stimulating target cells, and more particularly to using optics to stimulate the target cells.

### BACKGROUND

**[0003]** The stimulation of various cells of the body has been used to produce a number of beneficial effects. One method of stimulation involves the use of electrodes to introduce an externally generated signal into cells. One problem faced by electrode-based brain stimulation techniques is the distributed nature of neurons responsible for a given mental process. Conversely, different types of neurons reside close to one another such that only certain cells in a given region of the brain are activated while performing a specific task. Alternatively stated, not only do heterogeneous nerve tracts move in parallel through tight spatial confines, but the cell bodies themselves may exist in mixed, sparsely embedded configurations. This distributed manner of processing seems to defy the best attempts to understand canonical order within the CNS, and makes neuromodulation a difficult therapeutic endeavor. This architecture of the brain poses a problem for electrode-based stimulation because electrodes are relatively indiscriminate with regards to the underlying physiology of the neurons that they stimulate. Instead, physical proximity of the electrode poles to the neuron is often the single largest determining factor as to which neurons will be stimulated. Accordingly, it is generally not feasible to absolutely restrict stimulation to a single class of neuron using electrodes.

**[0004]** Another issue with the use of electrodes for stimulation is that because electrode placement dictates which neurons will be stimulated, mechanical stability is frequently inadequate, and results in lead migration of the electrodes from the targeted area. Moreover, after a period of time within the body, electrode leads frequently become encapsulated with glial cells, raising the effective electrical resistance of the electrodes, and hence the electrical power delivery required to reach targeted cells. Compensatory increases in voltage, frequency or pulse width, however, may spread the electrical current and increase the unintended stimulation of additional cells.

**[0005]** Another method of stimulus uses photosensitive bio-molecular structures to stimulate target cells in response to light. For instance, light activated proteins can be used to control the flow of ions through cell membranes. By facilitating or inhibiting the flow of positive or negative ions

through cell membranes, the cell can be briefly depolarized, depolarized and maintained in that state, or hyperpolarized. Neurons are an example of a type of cell that uses the electrical currents created by depolarization to generate communication signals (i.e., nerve impulses). Other electrically excitable cells include skeletal muscle, cardiac muscle, and endocrine cells. Neurons use rapid depolarization to transmit signals throughout the body and for various purposes, such as motor control (e.g., muscle contractions), sensory responses (e.g., touch, hearing, and other senses) and computational functions (e.g., brain functions). Thus, the control of the depolarization of cells can be beneficial for a number of different purposes, including (but not limited to) psychological therapy, muscle control and sensory functions.

### SUMMARY

**[0006]** The claimed invention is directed to photosensitive bio-molecular structures and related methods. The present invention is exemplified in a number of implementations and applications, some of which are summarized below.

**[0007]** According to one example embodiment of the present invention, an implantable arrangement is implemented having a light-generation device for generating light. The arrangement also has a biological portion that modifies target cells for stimulation in response to light generated by the light-generation means in vivo.

**[0008]** According to another example embodiment of the present invention, target cells are stimulated using an implantable arrangement. The arrangement includes an electrical light-generation means for generating light and a biological portion. The biological portion has a photosensitive bio-molecular arrangement that responds to the generated light by stimulating target cells in vivo. Stimulation may be manifest as either upregulation, or down-regulation of activity at the target.

**[0009]** According to another example embodiment of the present invention, an implantable device delivers gene transfer vector, such as a virus, which induces expression of photosensitive bio-molecular membrane proteins. The device has a light generator, responsive to (for example, charged by or triggered by) an external signal, to generate light and a biological arrangement that includes the photosensitive bio-molecular protein that responds to the generated light by interacting with target cells in vivo. In this manner, the electronic portions of the device may be used to optically stimulate target cells. Stimulation may be manifested as either upregulation (e.g., increased neuronal firing activity), or downregulation (e.g., neuronal hyperpolarization, or alternatively, chronic depolarization) of activity at the target.

**[0010]** According to another example embodiment of the present invention, a method is implemented for stimulating target cells using photosensitive proteins that bind with the target cells. The method includes a step of implanting the photosensitive proteins and a light generating device near the target cells. The light generating device is activated and the photosensitive protein stimulates the target cells in response to the generated light.

**[0011]** Applications include those associated with any population of electrically-excitabile cells, including neurons, skeletal, cardiac, and smooth muscle cells, and insulin-secreting pancreatic beta cells. Major diseases with altered excitation-effector coupling include heart failure, muscular

dystrophies, diabetes, pain, cerebral palsy, paralysis, depression, and schizophrenia. Accordingly, the present invention has utility in the treatment of a wide spectrum of medical conditions, from Parkinson's disease and brain injuries to cardiac dysrhythmias, to diabetes, and muscle spasm.

**[0012]** According to other example embodiments of the present invention, methods for generating an inhibitory neuron-current flow involve, in a neuron, engineering a protein that responds to light by producing an inhibitory current to dissuade depolarization of the neuron. In one such method, the protein is halorhodopsin-based and in another method the protein is an inhibitory protein that uses an endogenous cofactor.

**[0013]** According to another example embodiment of the present invention, a method for controlling action potential of a neuron involves the following step: engineering a first light responsive protein in the neuron; producing, in response to light, an inhibitory current in the neuron and from the first light responsive protein; engineering a second light responsive protein in the neuron; and producing, in response to light, an excitation current in the neuron from the second light responsive protein.

**[0014]** In another method for controlling a voltage level across a cell membrane of a cell, the method comprises: engineering a first light responsive protein in the cell; measuring the voltage level across the cell membrane; and producing, in response to light of a first wavelength and using the first light responsive protein, a current across the cell membrane that is responsive to the measured voltage level.

**[0015]** The above summary of the present invention is not intended to describe each illustrated embodiment or every implementation of the present invention. The figures and detailed description that follow more particularly exemplify these embodiments.

#### BRIEF DESCRIPTION OF THE DRAWINGS

**[0016]** The invention may be more completely understood in consideration of the detailed description of various embodiments of the invention that follows in connection with the accompanying drawings, in which:

**[0017]** FIG. 1 shows a block diagram of a system for stimulating target cells, according to an example embodiment of the present invention;

**[0018]** FIG. 2 shows a block diagram of an implantable device for stimulating target cells, according to an example embodiment of the present invention;

**[0019]** FIG. 3 shows a block diagram of an implantable device, according to an example embodiment of the present invention;

**[0020]** FIG. 4A shows a block diagram of an implantable device, according to an example embodiment of the present invention;

**[0021]** FIG. 4B shows a circuit diagram corresponding to the block diagram of FIG. 4A, according to an example embodiment of the present invention;

**[0022]** FIG. 5A and FIG. 5B show a diagram of a mesh for containing photosensitive bio-molecules, according to an example embodiment of the present invention;

**[0023]** FIG. 6A and FIG. 6B show a diagram of a viral matrix, according to an example embodiment of the present invention;

**[0024]** FIG. 7 shows a circuit diagram of a circuit that produces light in response to a magnetic field, according to an example embodiment of the present invention;

**[0025]** FIGS. 8A, 8B and 8C show a block diagram and circuits for the production of light in response to a RF signal, according to an example embodiment of the present invention;

**[0026]** FIG. 9A and FIG. 9B each show a diagram of a fiber-optic device, according to an example embodiment of the present invention;

**[0027]** FIGS. 10A, 10B, 10C and 10D depict various stages in the production of a photosensitive biological portion, according to an example embodiment of the present invention;

**[0028]** FIG. 11 shows an implantation device, according to an example embodiment of the present invention;

**[0029]** FIG. 12A and FIG. 12B show a diagram for another implantation device, according to an example embodiment of the present invention;

**[0030]** FIGS. 13A, 13B, 13C, 13D, 13E, 13F, 13G, 13H, 13I, 13J, 13K, 13L and 13M show experimental results that are consistent with an example embodiment of the present invention;

**[0031]** FIGS. 14A, 14B, 14C, 14D, 14E and 14F show experimental results that are consistent with an example embodiment of the present invention;

**[0032]** FIGS. 15A, 15B, 15C, 15D, 15E and 15F, show experimental results that are consistent with an example embodiment of the present invention;

**[0033]** FIG. 16 depicts an arrangement with multiple light sources, according to an example embodiment of the present invention;

**[0034]** FIG. 17 shows a system for controlling electrical properties of one or more cells in vivo, according to an example embodiment of the present invention;

**[0035]** FIG. 18 shows a system for controlling electrical properties of one or more cells in vivo, according to an example embodiment of the present invention;

**[0036]** FIG. 19A shows a block diagram of a system for optical drug screening, according to an example embodiment of the present invention;

**[0037]** FIG. 19B shows a specific system diagram of a large-format, quasi-automated system for drug screening in accordance with the present methodology, according to an example embodiment of the present invention;

**[0038]** FIG. 20 shows a system diagram of a small-format, fully automated drug screening system which operates in accordance with the invented methodology, according to an example embodiment of the present invention;

**[0039]** FIG. 21A depicts the workings of an example of emitter/detector units, according to an example embodiment of the present invention;

**[0040]** FIG. 21B depicts the workings of another embodiment of emitter/detector units, according to an example embodiment of the present invention;

**[0041]** FIG. 22 depicts an electronic circuit mechanism for activating the LED emitters used within the emitter/detector units, according to an example embodiment of the present invention;

**[0042]** FIG. 23 depicts an electronic circuit mechanism for light detection by the emitter/detector units, according to an example embodiment of the present invention;

[0043] FIG. 24 shows a timeline for a sequence of events in the context of an example screening process, according to an example embodiment of the present invention;

[0044] FIG. 25 illustrates an example of a layout of cell and drug samples within the wells of a well-plate, according to an example embodiment of the present invention; and

[0045] FIG. 26 illustrates the context in which the disclosed invention may be employed within a larger system that facilitates high-throughput drug screening, according to an example embodiment of the present invention.

[0046] While the invention is amenable to various modifications and alternative forms, specifics thereof have been shown by way of example in the drawings and will be described in detail. It should be understood, however, that the intention is not to limit the invention to the particular embodiments described. On the contrary, the intention is to cover all modifications, equivalents, and alternatives falling within the spirit and scope of the invention.

#### DETAILED DESCRIPTION

[0047] The present invention is believed to be useful for facilitating practical application of a variety of photosensitive bio-molecular structures, and the invention has been found to be particularly suited for use in arrangements and methods dealing with cellular membrane voltage control and stimulation. While the present invention is not necessarily limited to such applications, various aspects of the invention may be appreciated through a discussion of various examples using this context.

[0048] Consistent with one example embodiment of the present invention, a light-responsive protein is engineered in a cell. The protein affects a flow of ions across the cell membrane in response to light. This change in ion flow creates a corresponding change in the electrical properties of the cells including, for example, the voltage and current flow across the cell membrane. In one instance, the protein functions in vivo using an endogenous cofactor to modify ion flow across the cell membrane. In another instance, the protein changes the voltage across the cell membrane so as to dissuade action potential firing in the cell. In yet another instance, the protein is capable of changing the electrical properties of the cell within several milliseconds of the light being introduced. For further details on delivery of such proteins, reference may be made to U.S. patent application Ser. No. 11/459,636 filed on Jul. 24, 2006 and entitled "Light-Activated Cation Channel and Uses Thereof", which is fully incorporated herein by reference.

[0049] Consistent with a more specific example embodiment of the present invention a protein, NpHR, from *Natronomonas pharaonis* is used for temporally-precise optical inhibition of neural activity. NpHR allows for selective inhibition of single action potentials within rapid spike trains and sustained blockade of spiking over many minutes. The action spectrum of NpHR is strongly red-shifted relative to ChR2 but operates at similar light power, and NpHR functions in mammals without exogenous cofactors. In one instance, both NpHR and ChR2 can be expressed in the target cells. Likewise, NpHR and ChR2 can be targeted to *C. elegans* muscle and cholinergic motoneurons to control locomotion bidirectionally. In this regard, NpHR and ChR2 form an optogenetic system for multimodal, high-speed, genetically-targeted, all-optical interrogation of living neural circuits.

[0050] Certain aspects of the present invention are based on the identification and development of an archaeal light-driven chloride pump, such as halorhodopsin (NpHR), from *Natronomonas pharaonis*, for temporally-precise optical inhibition of neural activity. The pump allows both knockout of single action potentials within rapid spike trains and sustained blockade of spiking over many minutes, and it operates at similar light power compared to ChR2 but with a strongly red-shifted action spectrum. The NpHR pump also functions in mammals without exogenous cofactors.

[0051] According to other example embodiments of the present invention, methods for generating an inhibitory neuron-current flow involve, in a neuron, engineering a protein that responds to light by producing an inhibitory current to dissuade depolarization of the neuron. In one such method, the protein is halorhodopsin-based and in another method the protein is an inhibitory protein that uses an endogenous cofactor.

[0052] In another example embodiment, a method for controlling action potential of a neuron involves the following steps: engineering a first light responsive protein in the neuron; producing, in response to light, an inhibitory current in the neuron and from the first light responsive protein; engineering a second light responsive protein in the neuron; and producing, in response to light, an excitation current in the neuron from the second light responsive protein.

[0053] In another method for controlling a voltage level across a cell membrane of a cell, the method includes: engineering a first light responsive protein in the cell; measuring the voltage level across the cell membrane; and producing, in response to light of a first wavelength and using the first light responsive protein, a current across the cell membrane that is responsive to the measured voltage level.

[0054] Another aspect of the present invention is directed to a system for controlling an action potential of a neuron in vivo. The system includes a delivery device, a light source, and a control device. The delivery device introduces a light responsive protein to the neuron, with the light responsive protein producing an inhibitory current. The light source generates light for stimulating the light responsive protein, and the control device controls the generation of light by the light source.

[0055] In more detailed embodiments, such a system is further adapted such that the delivery device introduces the light responsive protein by one of transfection, transduction and microinjection, and/or such that the light source introduces light to the neuron via one of an implantable light generator and fiber-optics.

[0056] Another aspect of the present invention is directed to a method for treatment of a disorder. The method targets a group of neurons associated with the disorder; and in this group, the method includes engineering an inhibitory proteins that use an endogenous cofactor to respond to light by producing an inhibitory current to dissuade depolarization of the neurons, and exposing the neurons to light, thereby dissuading depolarization of the neurons.

[0057] According to yet another aspect of the present invention is directed to identifying and developing an archaeal light-driven chloride pump, such as halorhodopsin (NpHR), from *Natronomonas pharaonis*, for temporally-precise optical inhibition of neural activity. The pump allows both knockout of single action potentials within rapid spike trains and sustained blockade of spiking over many minutes,

and it operates at similar light power compared to ChR2 but with a strongly red-shifted action spectrum. The NpHR pump also functions in mammals without exogenous cofactors.

**[0058]** More detailed embodiments expand on such techniques. For instance, another aspect of the present invention co-expresses NpHR and ChR2 in the species (e.g., a mouse and *C. elegans*). Also, NpHR and ChR2 are integrated with calcium imaging in acute mammalian brain slices for bidirectional optical modulation and readout of neural activity. Likewise, NpHR and ChR2 can be targeted to *C. elegans* muscle and cholinergic motoneurons to control locomotion bidirectionally. Together NpHR and ChR2 can be used as a complete and complementary opto-genetic system for multimodal, high-speed, genetically-targeted, all-optical interrogation of living neural circuits.

**[0059]** In addition to NpHR and ChR2, there are a number of channelrhodopsins, halorhodopsins, and microbial opsins that can be engineered to optically regulate ion flux or second messengers within cells. Various embodiments of the invention include codon-optimized, mutated, truncated, fusion proteins, targeted versions, or otherwise modified versions of such ion optical regulators. Thus, ChR2 and NpHR (e.g., GenBank accession number is EF474018 for the ‘mammalianized’ NpHR sequence and EF474017 for the ‘mammalianized’ ChR2(1-315) sequence) are used as representative of a number of different embodiments. Discussions specifically identifying ChR2 and NpHR are not meant to limit the invention to such specific examples of optical regulators. For further details regarding the above mentioned sequences reference can be made to “Multimodal fast optical interrogation of neural circuitry” by Feng Zhang, et al, Nature (Apr. 5, 2007) Vol. 446: 633-639, which is fully incorporated herein by reference.

**[0060]** Consistent with one example embodiment of the present invention, target cells are stimulated using an implantable arrangement. The implantable arrangement includes a biological portion that facilitates the stimulation of the target cells in response to receipt of light. The implantable arrangement also includes a light generator for creating light to trigger the stimulus of the target cells.

**[0061]** Consistent with another example embodiment of the present invention, a method is implemented for stimulating target cells in vivo using gene transfer vectors (for example, viruses) capable of inducing photosensitive ion channel growth (for example, ChR2 ion channels). The vectors are implanted in the body, along with the electronic components of the apparatus. A light producing device is implanted near the target cells. The target cells are stimulated in response to light generated by the light producing device.

**[0062]** Consistent with a particular embodiment of the present invention, a protein is introduced to one or more target cells. When introduced into a cell, the protein changes the potential of the cell in response to light having a certain frequency. This may result in a change in resting potential that can be used to control (dissuade) action potential firing. In a specific example, the protein is a halorhodopsin that acts as a membrane pump for transferring charge across the cell membrane in response to light. Membrane pumps are energy transducers which use electromagnetic or chemical bond energy for translocation of specific ions across the membrane. For further information regarding halorhodopsin membrane pumps reference can be made to “Halorhodopsin

Is a Light-driven Chloride Pump” by Brigitte Schobert, et al, The Journal of Biological Chemistry Vol. 257, No. 17. Sep. 10, 1982, pp. 10306-10313, which is fully incorporated herein by reference.

**[0063]** The protein dissuades firing of the action potential by moving the potential of the cell away from the action potential trigger level for the cell. In many neurons, this means that the protein increases the negative voltage seen across the cell membrane. In a specific instance, the protein acts as a chloride ion pump that actively transfers negatively charged chloride ions into the cell. In this manner, the protein generates an inhibitory current across the cell membrane. More specifically, the protein responds to light by lowering the voltage across the cell thereby decreasing the probability that an action potential or depolarization will occur.

**[0064]** As used herein, stimulation of a target cell is generally used to describe modification of properties of the cell. For instance, the stimulus of a target cell may result in a change in the properties of the cell membrane that can lead to the depolarization or polarization of the target cell. In a particular instance, the target cell is a neuron and the stimulus affects the transmission of impulses by facilitating or inhibiting the generation of impulses by the neuron.

#### Implantable Device

**[0065]** Consistent with another example embodiment of the present invention, the target cells are neurons located in the brain of a mammal. The target cells are genetically modified to express photosensitive bio-molecular arrangement, for example, ChR2 ion channels. Light can then be used to stimulate the neurons. Depending upon a number of factors, such as the location within the brain and the frequency and length of stimulation, different objectives can be achieved. For instance, current techniques for deep brain stimulus (DBS) use electrodes to apply a current directly to the targeted area of the brain. The frequency of the electrical stimulus is sometimes referred to as either low-frequency DBS or high-frequency DBS. Studies have suggested that high-frequency DBS inhibits the generation of impulses from the stimulated cells, while low-frequency DBS facilitates the generation of impulses from the stimulated cells. The frequencies that produce the effects of high-frequency of low-frequency DBS have also been shown to vary depending upon the specific area of the brain being stimulated. According to one example of high-frequency DBS, the neurons are stimulated using electrodes supplying current pulses at frequencies around 100 Hz or more. Such a frequency has been shown to be effective in certain applications, as discussed further herein.

**[0066]** A specific example of DBS is used for the treatment of Parkinson’s disease. In this application, DBS is often applied to the globus pallidus interna, or the subthalamic nucleus within a patient’s brain. By implanting a biological arrangement that modifies the cells to respond to light, a light flashing light can be used in place of electrodes. Thus, the targeted neuron cells and external electrical signal need not be directly applied to the targeted cells. Moreover, light can often travel from its point of origin farther than electricity, thereby increasing the effective area relative to the stimulation source and only those neurons that have been photosensitized are stimulated.

**[0067]** As with the electrode-based DBS methods, one embodiment of the present invention can be implemented

using high-frequency DBS to inhibit neuron generated impulses. While high-frequency DBS has been accomplished at frequencies around 100 Hz, high-frequency DBS using various embodiments of the present invention may not necessarily require the same frequency. For instance, it may be possible to reproduce the inhibiting effects of high-frequency DBS at lower frequencies (e.g., 50 Hz) when using light activated techniques. For example, activation of the halorhodopsin (NpHR) channel intrinsically favors hyperpolarization and resistance to action potential generation. Also, a light-sensitive ion channel may recover more slowly than naturally occurring mammalian ion channels, thus slowing the repolarization (and hence overall reactivity) of a neuron. Thus, various frequencies can be used depending upon the particular application (e.g., the targeted portion of the brain and the desired effect), and the stimulation modality being applied.

[0068] Consistent with another example embodiment of the present invention, gene transfer vectors inducing the expression of photosensitive bio-molecules are used to target a specific type of cell. For instance, viral-based proteins (e.g., lentiviruses, adeno-associated viruses or retroviruses) can be created to target specific types of cells, based upon the proteins that they uniquely express. The targeted cells are then infected by the viral-based gene-transfer proteins, and begin to produce a new type of ion channel (for example ChR2), thereby becoming photosensitive. This can be particularly useful for stimulating the targeted cells without stimulating other cells that are in proximity to the targeted cells. For example, neurons of disparate length, diameter, chronaxie, other membrane properties, electrical insulation, neurotransmitter output, and overall function, lie in close proximity to one another, and thus, can be inadvertently stimulated when using electrodes to provide the stimulation of the neurons. For further details on the generation of viral vectors and the in vivo modification and stimulation of neural cells, reference may be made to U.S. patent application Ser. No. 11/459,636 filed on Jul. 24, 2006, "An optical neural interface: in vivo control of rodent motor cortex with integrated fiberoptic and optogenetic technology" by Alexander M. Aravanis, et al, *Journal Neural Engineering* 4 (2007) S143-S156, "Neural substrates of awakening probed with optogenetic control of hypocretin neurons" by Antoine R. Adamantidis, et al, *Nature*, (Nov. 15, 2007) Vol. 450: 420-424, "Targeting and Readout Strategies for Fast Optical Neural Control In Vitro and In Vivo" by Viviana Gradinaru, et al, *The Journal of Neuroscience*, (Dec. 26, 2007) 27(52): 14231-14238, "Multimodal fast optical interrogation of neural circuitry" by Feng Zhang, et al, *Nature* (Apr. 5, 2007) Vol. 446: 633-639, "Circuit-breakers: optical technologies for probing neural signals and systems" by Feng Zhang, et al, *Nature Reviews Neuroscience* (August 2007) Vol. 8: 577-581, which are each fully incorporated herein by reference.

[0069] A specific embodiment of the present invention employs an implantable arrangement for in vivo use. A light-emitting diode, laser or similar light source is included for generating light (as shown, for example, light generator 104 in FIG. 1). A biological portion that modifies target cells to facilitate stimulation of the target cells in response to light generated by the light source.

[0070] Another embodiment of the present invention employs an arrangement for stimulating target cells using a photosensitive protein that allows the target cells to be

stimulated in response to light. A biological deliver device, such as those discussed in connection with biological portion 204, is used for implanting vectors that modify the target cells to include the photosensitive protein. An implantation component, such as that discussed in connection with biological portion 204, the mesh of FIG. 5 or viral matrix of FIG. 6, is used for implanting a light generating device near the target cells. A control device, such as that discussed in connection control circuit 208, is used for activating the light generating device to generate light to be received by the target cells, thereby stimulating the target cells in response to the generated light.

[0071] Turning now to the figures, FIG. 1 shows a block diagram of a system for stimulating target cells, according to an example embodiment of the present invention. Block 102 represents a location internal to an organism (e.g., a mammal), as shown by the in vivo designation. Light generator 104 is an implantable device that generates light in vivo. The photosensitive biological portion 106 affects the target cells such that generated light strikes causes stimulation of the target. In one instance, the light generator 104 is a small electronic device on the order of a few millimeters in size. The small size is particularly useful for minimizing the intrusiveness of the device and associated implantation procedure. In another instance, the light generator 104 may include a fiber optic device that can be used to transmit light from an external source to the target cells.

[0072] In one embodiment of the present invention, the target cells are modified to contain light-activated ion channel proteins. A specific example of such protein is channel-rhodopsin-2 (ChR2), which is a product based upon green alga *Chlamydomonas reinhardtii*.

[0073] These light sensitive proteins can be implanted using a number of different methods. Example methods include, but are not limited to, the use of various delivery devices, such as gelatin capsules, liquid injections and the like. Such methods also include the use of stereotactic surgery techniques such as frames or computerized surgical navigation systems to implant or otherwise access areas of the body.

[0074] FIG. 2 shows a block diagram of an implantable device for stimulating target cells, according to an example embodiment of the present invention. The figure includes control circuit 208, light source 206, biological portion 204 and target cells 202. Biological portion 204 affects the target cells 202 such that the target cells are stimulated in response to light

[0075] In one embodiment of the present invention, biological portion 204 may be composed of target cells 202 that have been modified to be photosensitive. In another embodiment of the present invention, biological portion 204 may contain biological elements such as gene transfer vectors, which cause target cells 202 to become sensitive to light. An example of this is lentiviruses carrying the gene for ChR2 expression. In this manner, the stimulation of target cells 202 can be controlled by the implantable device. For example, the control circuit 208 can be arranged to respond to an external signal by activating, or deactivating light source 206, or by charging the battery that powers light source 206. In one instance, the external signal is electromagnetic radiation that is received by control circuit 208. For example, radio frequency (RF) signals can be transmitted by an external RF transmitter and received by control circuit 208.



In another example, a magnetic field can be used to activate and/or power the control circuit.

[0076] Control circuit **208** can be implemented using varying degrees of complexity. In one instance, the circuit is a simple coil that when exposed to a magnetic field generates a current. The current is then used to power light source **206**. Such an implementation can be particularly useful for limiting the size and complexity as well as increasing the longevity of the device. In another instance, control circuit **208** can include an RF antenna. Optionally, a battery or similar power source, such as a capacitive element, can be used by control circuit **208**. While charged, the power source allows the circuitry to continue to operate without need for concurrent energy delivery from outside the body. This can be particularly useful for providing precise control over the light emitted by light source **206** and for increased intensity of the emitted light.

[0077] In one embodiment of the present invention, light source **206** is implemented using a light-emitting-diode (LED). LEDs have been proven to be useful for low power applications and also to have a relatively fast response to electrical signals.

[0078] In another embodiment of the present invention, biological portion **204** includes a gelatin or similar substance that contains gene transfer vectors which genetically code the target cells for photosensitivity. In one instance, the vectors are released once implanted into the body. This can be accomplished, for example, by using a containment material that allows the vectors to be released into aqueous solution (e.g., using dehydrated or water soluble materials such as gelatins). The release of the vectors results in the target cells being modified such that they are simulated in response to light from light source **206**.

[0079] In another embodiment of the present invention, the biological portion **204** includes a synthetic mesh that contains the photosensitive cells. In one instance, the cells are neurons that have been modified to be photosensitive. The synthetic mesh can be constructed so as to allow the dendrites and axons to pass through the mesh without allowing the entire neuron (e.g., the cell body) to pass. One example of such a mesh has pores that are on the order of 3-7 microns in diameter and is made from polyethylene terephthalate. In another example embodiment, the biological portion **204** includes an injection mechanism as discussed in further detail herein.

[0080] FIG. 3 shows a block diagram of an implantable device, according to an example embodiment of the present invention. The implantable device of FIG. 3 is responsive to a field magnetic. More specifically, an inductor constructed from windings **302** and core **304** generates a current/voltage in response to a magnetic field. The current is passed to control circuit **310** through conductive path **306**. In response, control circuit **310** activates light source **312** using conductive path **308**. Light source **312** illuminates biological portion **314** in order to stimulate the target cells. In one instance, biological portion **314** includes a gelatin, synthetic mesh or injection mechanism as discussed in further detail herein.

[0081] In one embodiment of the present invention, the control portion can be a simple electrical connection, resistive element, or can be removed completely. In such an embodiment, the intensity, duration and frequency of light generated would be directly controlled by the current generated from a magnetic field. This can be particularly useful

for creating inexpensive, long lasting and small devices. An example of such an embodiment is discussed further in connection with FIG. 4A and FIG. 4B.

[0082] In another embodiment of the present invention, the control portion can be implemented as a more complex circuit. For instance the control circuit may include and otherwise implement different rectifier circuits, batteries, pulse timings, comparator circuits and the like. In a particular example, the control circuit includes an integrated circuit (IC) produced using CMOS or other processes. Integrated circuit technology allows for the use of a large number of circuit elements in a very small area, and thus, a relatively complex control circuit can be implemented for some applications.

[0083] In a particular embodiment of the present invention, the inductor (**302** and **304**) is a surface mount inductor, such as a 100 uH inductor part number CF1008-103K supplied by Gowanda Electronics Corp. The light generating portion is a blue LED, such as LEDs in 0603 or 0805 package sizes. A particular example is a blue surface mount LED having part number SML0805, available from LEDtronics, Inc (Torrance, Calif.). Connective paths **306** and **308** can be implemented using various electrical conductors, such as conductive epoxies, tapes, solder or other adhesive materials. LEDs emitting light in the amber spectrum (as applicable to NpHR channels) are available through commercial sources including this same manufacturer.

[0084] FIG. 4A shows a block diagram of an implantable device, according to an example embodiment of the present invention. FIG. 4A shows an inductor comprising coils **402** and core **404** connected to LED **408** using conductive paths shown by **406**. FIG. 4B shows a circuit diagram corresponding to the block diagram of FIG. 4A. Inductor **412** is connected in parallel to LED **410**. Thus, current and voltage generated by changing a magnetic field seen at inductor **412** causes LED **410** to produce light. The frequency and strength of the changing magnetic field can be varied to produce the desired amount and periodicity of light from LED **410**.

[0085] FIG. 5A and FIG. 5B show a diagram of a mesh for containing photosensitive bio-molecules, according to an example embodiment of the present invention. Mesh **502** is constructed having holes **504** of a size that allows illumination to pass but is small enough to prevent cells **506** to pass. This allows for cells **506** to be implanted while still receiving light from a light generator.

[0086] In one embodiment of the present invention, the cells **506** are stem cells that are modified to be photosensitive. The stem cells are allowed to mature as shown by FIG. 5B. In a particular instance, the stem cells mature into neurons having a cell body **512**, axons/dendrites **508** and **510**. The neurons are genetically modified to be photosensitive. Holes **504** are on the order of 3-7 microns in diameter. This size allows some axons and dendrites to pass through holes **504**, while preventing the cell body **512** to pass.

[0087] FIG. 6A and FIG. 6B show a diagram of a viral matrix, according to an example embodiment of the present invention. The viral matrix includes structure **602**, which contains viral vectors **604**. In one instance, structure **602** includes a gel or fluid substance that contains viral vectors **604** until they are implanted in a mammal **606**. Once viral vectors **604** are released, they infect target cells **608** in the vicinity of the implanted viral matrix as shown by FIG. 6B.

Infected target cell **610** becomes photosensitive, and thus, light can be used to control the stimulation of target cell **610**.

[0088] According to one embodiment of the present invention, structure **602** is a gelatin that has been impregnated, or otherwise sealed with viral vectors **604** contained within the gelatin. When structure **602** is implanted, the gelatin is hydrated and or dissolved, thereby releasing viral vectors **604**. Standard commercially available gelatin mix may be used, in addition to compounds such as Matrigel by BD Biosciences division of Becton Dickenson and Company (Franklin Lakes, N.J.)

[0089] FIG. 7 shows a circuit diagram of a circuit that produces light in response to a magnetic field, according to an example embodiment of the present invention. FIG. 7 includes an input circuit **720** and an output circuit **730**. Inductor **704** generates current in response to magnetic field **702**. Due to properties of magnetic fields, the current produced by inductor **704** is an alternating current (AC) signal. Full-wave bridge rectifier **706** rectifies the AC signal and along with an RC circuit generates a relatively stable voltage from the AC signal. This generated voltage is responsive to magnetic field **702** and output circuit **730** generates light when the generated voltage is at a sufficient level. More specifically, power from battery **708** is used to drive LED **710** in response to magnetic field **702**. This is particularly useful for applications where the magnetic field **702** seen by inductor **704** is less powerful (e.g., due to the in vivo location of inductor **704**).

[0090] FIG. 8A shows a circuit diagram of a circuit that produces light in response to RF signal **801**, according to an example embodiment of the present invention. Antenna **802** is used to receive RF transmission **801** and convert the signal to electricity. The received transmission is rectified by diode **803** and further filtered by capacitor **805**. In a one instance, diode **803** can be implemented using a diode having a low forward bias and fast switching capabilities, such as a Schottky diode.

[0091] In a particular embodiment of the present invention, RF transmission **801** contains a power component for charging battery **815** and a signal component for controlling LED **825**. Capacitor **805** can be selected to separate these components for use by the circuit. For instance, the power component may be a relatively low-frequency, large-amplitude signal, while the signal component is a relatively high-frequency, small-amplitude signal. Capacitor **805** can be selected to filter the power component of the signal to create a corresponding voltage. The remaining high-frequency component of the RF transmission is added to this voltage. The power component of the transmission can then be used to charge on the battery **815**, and the signal component of the transmission is used to enable LED **825**. The light generated by LED **825** to triggers stimulus of the target cells **827**.

[0092] FIG. 8B illustrates an alternative embodiment radio-frequency energy accumulator, which charges a battery, which in turn, powers a digital pulse generator, which powers a LED. An electromagnetic signal **850** is received by loop antenna **852** generating a corresponding electrical signal. The voltage generated from loop antenna **852** is limited by the reverse bias voltage of the diodes **855** and **856** and stored in capacitor **854**. In a particular instance these diodes have a low reverse bias voltage that is relatively precise, such as a Zener diode. Electromagnetic signal **850** is rectified via diode rectifier bridge **858** and filtered by

voltage regulator **859** to produce a DC voltage. The DC can be used to charge power source **860**.

[0093] Battery **860** is coupled to the input of Schmidt trigger **865** through capacitor **862**. Feedback from the output of the Schmidt trigger is provided through resistor **864** relative to the charge on capacitor **863**. Accordingly, the frequency of the square-wave output of Schmidt trigger **865** is determined by the values of the resistor-capacitor network including capacitor **863** and resistor **864**. Resistor **864** and capacitor **863** may be fixed or variable. The output of Schmidt trigger **865** is fed through digital inverter **867** which powers LED **866**. Light from LED **866** is transmitted to light-sensitive neurons **868** relative to the frequency of the square-wave output of Schmidt trigger **865**.

[0094] FIG. 8C illustrates block diagram for an electromagnetic field (EMF) energy accumulator and pulsing approach in which the received EMF **897** (for example radiofrequency energy) includes not only energy for accumulation, but also an encoded signal regarding instructions to microcontroller **895**. In step **885** (Energy plus Parameter Control Signal: Encoding and transmission), a control instruction signal is encoded to ride upon the energy component by methods known in the art, for example, by frequency modulation. Energy receiver block **890** uses a portion of the EMF signal to provide power to block **893**. Control signal receiver block **891** uses a portion of the EMF signal to provide control instructions to microcontroller block **895**.

[0095] The control instruction can be used to transmit information regarding the various parameters of the generated light, such as frequency, strength, duration, color, and the like. These instructions can be decoded and processed using a microcontroller or logic circuitry as shown by block **895**. Block **895** can generate control signal(s) in response to the decoded instructions. Accordingly, the frequency (and other parameters) of the light generated by LED **896** rate need not be fixed for the given implanted device. Antenna **889** delivers input to the Energy Receiver **890** (providing power to voltage regulator and battery circuitry **893**). Concurrently, antenna **889** delivers encoded data to Control Signal Receiver **891**, which provides control input to microcontroller **895** that drives LED **896**. Selected wavelength light **897** is then delivered to electrically excitable cell **898**. The battery in the voltage regulator and battery circuitry **893** provides power to the microcontroller **895** and the Control Signal Receiver **891**.

[0096] The circuit diagrams of FIG. 7 and FIGS. 8A, 8B and 8C are merely illustrative of a few particular embodiments of the present invention, and various other implementations are envisioned. For example, particular embodiments implement a light source that uses a blue LED; however, other colors and light sources can be implemented depending upon the particular application.

[0097] FIG. 9A and FIG. 9B each show a diagram of a fiber-optic device, according to an example embodiment of the present invention. The fiber-optic device includes a control portion **908**, a light generator **906** and a fiber optic cable **902**.

[0098] Fiber optic cable **902** can be positioned near a photosensitive biological portion, such as a viral matrix or synthetic mesh as discussed herein. This allows for control portion **908** and light generator **906** to be located at a distance from the target cells **910** (e.g., at a distance corresponding to the length of fiber-optic cable **902**). This can be

particularly useful for minimizing the size of the portion of the implanted device that is near the target cells, for example, where the target cells are located at or near a sensitive location within the brain. In some instances, the remote location of portions **908** and **906** also facilitates modifications of the device, including, but not limited to, replacement of various components (e.g., batteries), changes in stimulation frequency and length.

[0099] Control portion **908** can be configured to respond to an external signal, such as magnetic field or RF signals. Alternatively, control portion **908** can be configured to enable light generator **906** according to a programmed schedule or a combination of an external signal and a programmed response.

[0100] FIGS. **10A-10D** depict various stages in the production of a photosensitive biological portion, according to an example embodiment of the present invention. More specifically, FIG. **10A** shows molding structure **1004** having several molds **1002**. Molds **1002** are constructed to various sizes depending upon the particular application. In one such application, the molds are a few millimeters or less in diameter.

[0101] FIG. **10B** shows the molds **1002** from FIG. **10A** after applying a layer of gelatin or similar substance as shown by **1006** and **1008**. Moreover, viral vectors (shown by 'v') are in the upper two molds. These viruses may be suspended within media **1012**, which may be a liquid or gelatinous media. Such liquids include normal saline, HEPES-buffered saline and other known viral sustenance and transfer media. Suitable gelatinous media includes Matrigel (BD Biosciences, San Jose Calif.). These viral vectors are designed transfer genes for light-sensitization to the membranes of targeted cells after implantation.

[0102] FIG. **10C** shows a side view of mold **1006**. **1016** represents the molding structure that forms the shape of gelatin layer **1014**. Gelatin layer **1014** traps viral vectors contained within media **1012**. A top gelatin layer **1010** is applied to fully contain the viral vectors.

[0103] FIG. **10D** shows the resulting viral vector capsule. The viral vectors **1018** are contained within area **1022** by casing **1020**. Casing **1020** can be designed to dissolve or otherwise allow viral vectors **1018** to disseminate towards the target cells once implanted. In one instance, the capsule is constructed of a water soluble material, for example, gelatin, so that upon implantation the viral vectors are allowed to escape into the body. Water soluble capsule materials are well known in the pharmaceutical industry.

[0104] FIG. **11** shows an implantation device, according to an example embodiment of the present invention. Biological portion **1102** and light generation device **1108** are implanted using the implantation device. For example, the shaft of the device **1114** is positioned near the target cells. Next, a user of the device presses on portion **1116** which causes portion **1112** to place biological portion **1102** and light generation device **1108** near the target cells. The implantation device can then be removed.

[0105] FIG. **12A** and FIG. **12B** show a diagram for another implantation device, according to an example embodiment of the present invention. Implantable light generating device **1204** is surrounded by, and permeated by fluid channels **1202**. Fluid channels **1202** allow a solution **1210** containing bio-molecular material (e.g., photosensitizing viral vectors) to be injected immediately proximal to light generating device **1204** and the target cells. The fluid channels can be

located outside of device **1204** and/or within device **1204**, as shown by **1212** and **1214** respectively. In this manner, the viral vectors can be injected in large quantities or over a period of time. For instance, cells infected by viral vectors can revert back to their pre-infection state after a period of time. Using the device of FIG. **12A**, the viral vectors can be periodically reintroduced to the target cells. Alternatively, different viral vectors can be introduced through the fluid channels, allowing for targeting of different cells at the implantation site. This can be particularly useful for staged treatment through stimulation of different types of cells.

[0106] A specific embodiment of the present invention relates to a method for genetically modifying neurons to express light-sensitive ion channel Channelrhodopsin (ChR2). In this method, pulses of blue light causes ChR2 neurons to fire action potentials corresponding to each pulse. Depolarization and repolarization occur on a millisecond timescale making this method consistent with normal network neurophysiology.

[0107] Specific targeted neurons are modified using viral vectors for gene transfer. For further details on the generation of viral vectors reference can be made to Boyden et al 2005, Zhang et al 2006 entitled "Channelrhodopsin-2 and Optical Control of Excitable Cells," *Nature Methods* Vol. 3, No. 10, which is fully incorporated herein by reference. This transfection results in the introduction of a gene for a single protein, a cell membrane ion channel, known as "Channelrhodopsin 2", or "ChR2". In nature, ChR2 resides on the cellular membrane of unicellular green algae *Chlamydomonas reinhardtii*. Upon absorption of blue light (470-480 nm), this ion channel briefly opens, allowing cation influx. When transfected into a mammalian nerve cell, affected nerves become photosensitive, producing light-triggered action potentials. To produce this action potential, photosensitized nerves appear to require 5-10 mW/mm of blue light intensity, in flashes up to 30 Hz. In experimental conditions, 98% of the time, such a flash of light produces an action potential within 50  $\mu$ seconds of the flash, with a variability (jitter) of 5  $\mu$ seconds.

[0108] A neuronal-type specific feature which is also a robust promoter (for example, CaMKII $\alpha$ ) is inserted adjacent to the ChR2 code within the virus, and the line is propagated by calcium-phosphate cotransfection of 293FT cells. The supernatant is then centrifuged into viral pellets, which are placed within phosphate-buffered saline.

[0109] In a particular instance, application of an algal light-gated ion channel Channelrhodopsin-2 is used for photostimulation. The first 315 amino-acid residues of the algal Channelrhodopsin-2 (abbreviated as ChR2 when coupled with retinal, or Chop-2 for the gene) from *Chlamydomonas reinhardtii* can be used to impart fast photosensitivity upon mammalian nerve cells, by using a viral vector to insert the gene for ChR2 into targeted nerve cells which may subsequently express this gene. ChR2 is a seven-transmembrane protein with a molecule of all-trans retinal (ATR) bound at the core as a photosensor. Upon illumination with approximately 470 nm blue light, ATR isomerizes and triggers a conformational change to open the channel pore. As ChR2 is a light-sensitive ion channel, it allows an inward current to be evoked within 50  $\mu$ s of illumination. Combining ChR2 with ultrafast light switching it is possible to activate neurons at the temporal precision of single action potentials, reliably over sustained multiple action potential trains.

[0110] In another instance, application of bacterial light-gated chloride channel halorhodopsin (NpHR) is used for photostimulation. This ion channel can be imparted upon mammalian nerve cells by using a viral vector to insert the gene for NpHR into targeted nerve cells, which may subsequently express this gene. Upon illumination with approximately 550 to 626 nm amber light, active pumping of chloride ions into the neuronal cytoplasm results in hyperpolarization of the cell.

[0111] For each application, the underlying physical properties of the native signal can be considered when choosing the most suitable of these described photostimulation methods. Excitable cells distinguish inputs in part based on their temporal properties, channel recruitment patterns and amplitude or polarity characteristics. Regarding temporal properties, glutamate uncaging and ChR2 achieve responses on the millisecond time scale. Such responses are well suited for photostimulating pathways triggered by fast synaptic events and action potentials. Regarding channel recruitment patterns, glutamate uncaging directly activates native glutamate receptors and so may achieve physiological spatial patterns of subcellular excitation. However, the other photostimulation methods, via depolarization, will recruit native voltage-activated channels such as voltage-dependent calcium, sodium and potassium channels, and thereby activate native, spatially sensitive signaling pathways. With such methods, channels could be activated experimentally so that populations can be labeled via stereotactic injection of viruses that effect retrograde axonal transport, by taking advantage of region specific axonal projections. Just as with ChR2, other genetically based photostimulation methods (including NpHR) can use these targeting strategies, although some multicomponent systems may be difficult to implement without the use of transgenic technologies. For a photostimulation-based method, sufficient gene expression must be achieved to elicit physiologically relevant levels of current.

[0112] In a particular instance, ChR2 is activated with blue light (excitation around 470 nm). Successful photostimulation of ChR2-expressing cells requires at least 5 mW/mm<sup>2</sup> of blue light to reach the sample.

[0113] ChR2 has been estimated to possess a single-channel conductance as low as 50 femtosiemens. This would imply that between 100,000 and 1,000,000 ChR2 molecules would have to be generated and localized to the neuronal membrane to achieve the observed currents in the range of 1 nA (starting from a resting potential of -70 mV and neglecting space-clamp issues and changes in driving force due to ion entry).

[0114] Since sensitivity to blue light via ChR2 is induced when a viral vector inserts the ChR2 gene into a previously normal cell, the insertion may be genetically targeted to the products expressed by specific cellular subtypes. For example, it might be advantageous to cause only dopaminergic neurons, and not cholinergic neurons to react to blue light.

#### Expression in Neural or Stem Cells

[0115] As discussed above, one embodiment of the present invention involves the use of an optically responsive ion-pump that is expressed in a cell. In a particular instance, the cell is either a neural cell or a stem cell. A specific embodiment involves in vivo animal cells expressing the ion-pump. Certain aspects of the present invention are based on the

identification and development of an archaeal light-driven chloride pump, such as halorhodopsin (NpHR), from *Natronomonas pharaonis*, for temporally-precise optical inhibition of neural activity. The pump allows both knockout of single action potentials within rapid spike trains and sustained blockade of spiking over many minutes, and it operates at similar light power compared to ChR2 but with a strongly red-shifted action spectrum. The NpHR pump also functions in mammals without exogenous cofactors.

[0116] According to an example embodiment of the present invention, an optically responsive ion-pump and/or channel is expressed in one or more stem cells, progenitor cells, or progeny of stem or progenitor cells. Optical stimulation is used to activate expressed pumps/channels. The activation can be used to control the ion concentrations (e.g., chloride, calcium, sodium, and potassium) in the cells. This can be particularly useful for affecting the survival, proliferation, differentiation, de-differentiation, or lack of differentiation in the cells. Thus, optical stimulus is implemented to provide control over the (maturation) of stem or progenitor cells.

[0117] In a particular embodiment, optically-controlled stimulus patterns are applied to the stem or progenitor cells over a period of hours or days. For further details regarding the effects of membrane potentials and ion concentrations on such cells reference can be made to "Excitation-Neurogenesis Coupling in Adult Neural Stem/Progenitor Cells" by Karl Deisseroth, et al, *Neuron* (May 27, 2004) *Neuron*, Vol. 42, 535-552 and to U.S. Patent Publication No. 20050267011 (U.S. patent application Ser. No. 11/134,720) entitled "Coupling of Excitation and Neurogenesis in Neural Stem/Progenitor Cells" to Deisseroth et al and filed on May 19, 2005, which are each fully incorporated herein by reference.

[0118] According to other example embodiments of the present invention, methods for generating an inhibitory neuron-current flow involve, in a neuron, engineering a protein that responds to light by producing an inhibitory current to dissuade depolarization of the neuron. In one such method, the protein is halorhodopsin-based and in another method the protein is an inhibitory protein that uses an endogenous cofactor.

[0119] In another example embodiment, a method for controlling action potential of a neuron involves the following step: engineering a first light responsive protein in the neuron; producing, in response to light, an inhibitory current in the neuron and from the first light responsive protein; engineering a second light responsive protein in the neuron; and producing, in response to light, an excitation current in the neuron from the second light responsive protein.

[0120] In another method for controlling a voltage level across a cell membrane of a cell, the method comprises: engineering a first light responsive protein in the cell; measuring the voltage level across the cell membrane; and producing, in response to light of a first wavelength and using the first light responsive protein, a current across the cell membrane that is responsive to the measured voltage level.

[0121] Another aspect of the present invention is directed to a system for controlling an action potential of a neuron in vivo. The system includes a delivery device, a light source, and a control device. The delivery device introduces a light responsive protein to the neuron, with the light responsive protein producing an inhibitory current. The light source

generates light for stimulating the light responsive protein, and the control device controls the generation of light by the light source.

**[0122]** In more detailed embodiments, such a system is further adapted such that the delivery device introduces the light responsive protein by one of transfection, transduction and microinjection, and/or such that the light source introduces light to the neuron via one of an implantable light generator and fiber-optics.

**[0123]** Another aspect of the present invention is directed to a method for treatment of a disorder. The method targets a group of neurons associated with the disorder; and in this group, the method includes engineering an inhibitory proteins that use an endogenous cofactor to respond to light by producing an inhibitory current to dissuade depolarization of the neurons, and exposing the neurons to light, thereby dissuading depolarization of the neurons.

**[0124]** According to yet another aspect of the present invention is directed to identifying and developing an archaeal light-driven chloride pump, such as halorhodopsin (NpHR), from *Natronomonas pharaonis*, for temporally-precise optical inhibition of neural activity. The pump allows both knockout of single action potentials within rapid spike trains and sustained blockade of spiking over many minutes, and it operates at similar light power compared to ChR2 but with a strongly red-shifted action spectrum. The NpHR pump also functions in mammals without exogenous cofactors.

**[0125]** More detailed embodiments expand on such techniques. For instance, another aspect of the present invention co-expresses NpHR and ChR2 in the species (e.g., the mouse and *C. elegans*). Also, NpHR and ChR2 are integrated with calcium imaging in acute mammalian brain slices for bidirectional optical modulation and readout of neural activity. Likewise, NpHR and ChR2 can be targeted to *C. elegans* muscle and cholinergic motoneurons to control locomotion bidirectionally. Together these results demonstrate that NpHR and ChR2 form a complete and complementary optogenetic system for multimodal, high-speed, genetically-targeted, all-optical interrogation of living neural circuits.

**[0126]** To exemplary ion pumps originate from two strains of archaea, *Halobacterium salinarum* (HsHR) and *Natronomonas pharaonis* (NpHR). Illumination of HsHR or NpHR-expressing oocytes lead to rapid outward currents. Both HsHR and NpHR have excitation maxima near 580 nm as shown in FIG. 13A. Specifically FIG. 13A shows the action spectrum of NpHR when measured in *Xenopus* oocytes using a Xenon short arc lamp and narrowbandwidth 20 nm filters), which is red-shifted from the known ChR2 maximum of ~460 nm<sup>5</sup>. This spectral separation allows for ChR2 and an HR to be activated independently or in synchrony to effect bidirectional optical modulation of membrane potential.

**[0127]** In an experimental test, HsHR was found to have a lower extracellular Cl<sup>-</sup> affinity than NpHR (K<sub>m</sub>, NpHR=16 mM in FIG. 13B, K<sub>m</sub>,HsHR=32 mM) and measured currents displayed rapid rundown at low extracellular [Cl<sup>-</sup>] that did not fully recover in darkness. The influence of cytoplasmic [Cl<sup>-</sup>] on HR pump currents was studied using excised giant patches. HR pump currents were not influenced by cytoplasmic [Cl<sup>-</sup>] (from 0 to 124 mM), indicating a very low affinity for Cl<sup>-</sup> on the cytoplasmic side where Cl<sup>-</sup> ions are released, as expected since HR-mediated chloride

pumping can achieve molar concentrations of cytoplasmic Cl<sup>-</sup>. The pump current exhibits more or less linear voltage dependence, and Cl<sup>-</sup> current is robust for both HRs across all physiological voltage regimes.

**[0128]** In one instance, a mammalian codon-optimized NpHR gene fused with enhanced yellow fluorescent protein (NpHR-EYFP) was introduced into cultured rat hippocampal CA3/CA1 neurons using lentiviruses carrying the ubiquitous EF1- $\alpha$  promoter (EF1  $\alpha$ ::NpHR-EYFP). Cells expressing NpHR-EYFP exhibited robust expression for weeks after infection. In voltage clamp, illumination of NpHR-EYFP cells with yellow light (bandwidth 573-613 nm via Semrock filter FF01-593/40-25; 300 W xenon lamp) induced rapid outward currents (FIG. 13C, top) with a peak level of 43.8 $\pm$ 25.9 pA and a steady-state level of 36.4 $\pm$ 24.4 pA (mean s.d. reported throughout this paper, n=15; FIG. 13D). The relatively small difference between the peak and steady-state currents is indicative of rare deprotonation of the NpHR Schiff base during the pump cycle<sup>24</sup>. The rise time from light onset to 50% of the peak current is consistent across all cells (6.0 $\pm$ 1.0 ms; FIG. 13G) with rise and decay time constants of T<sub>on</sub>=6.1 $\pm$ 2.1 ms and T<sub>off</sub>=6.9 $\pm$ 2.2 ms respectively. Light-evoked responses were never seen in cells expressing EYFP alone. In current clamp, NpHR-EYFP neurons exhibited light-evoked hyperpolarization (FIG. 13C; bottom) with an average peak of 14.7 $\pm$ 6.9 mV and a steady-state of 12.1 $\pm$ 6.6 mV (FIG. 13F). The delay from light onset to 50% of hyperpolarization peak was 26.0 $\pm$ 8.6 ms (FIG. 13E) and the rise and decay time constants were T<sub>on</sub>=35.6 $\pm$ 15.1 ms and T<sub>off</sub>=40.5 $\pm$ 25.3 ms respectively. To test whether NpHR-mediated hyperpolarization could inhibit neuronal firing, current-clamped neurons were injected with a 200 pA current step for 2 s to evoke robust spike firing; concurrent light delivery abolished the evoked activity (FIG. 13G).

**[0129]** NpHR-EYFP and ChR2-mCherry were co-expressed in cultured hippocampal neurons and probed NpHR function using cell-attached recordings with ChR2 photostimulation to drive reliable spike trains. Indeed, whereas trains of blue light pulses were able to evoke action potentials, concomitant yellow light illumination abolished spike firing in both cell-attached and subsequent whole-cell recording modes (FIG. 13H). After achieving the whole-cell configuration, voltage-clamp recording showed that independent exposure to yellow or blue light led to outward or inward photocurrents respectively (FIG. 13I), further confirming that ChR2 and NpHR can be combined to achieve bidirectional, independently addressable modulation of membrane potential in the same neuron. Further confirming that NpHR inhibitory function does not require a specific pipette chloride concentration under these recording conditions, it was found that NpHR-mediated inhibition is robust across a range of relevant whole-cell pipette chloride concentrations (4-25 mM) and physiologically negative resting potentials, as expected from the fact that NpHR is designed to deliver chloride ions to molar levels in the archaeal intracellular milieu.

**[0130]** Extensive controls were conducted to test whether heterologous expression of NpHR in neurons would alter the membrane properties or survival of neurons. Lentiviral expression of NpHR for at least 2 weeks did not alter neuronal resting potential (-53.1 $\pm$ 6.3 mV for NpHR+ cells, -57.0 $\pm$ 4.8 mV for NpHR- cells, and -56.7 $\pm$ 5.7 mV for NpHR+ cells exposed to yellow light for 10 min followed by

a delay period of 1 day; FIG. 13J, n=12 each) or membrane resistance ( $114.5 \pm 34.1 \text{ M}\Omega$  for NpHR+ cells,  $108.9 \pm 20.1 \text{ M}\Omega$  for NpHR- cells, and  $111.4 \pm 23 \text{ M}\Omega$  for the light-exposed NpHR+ cells; FIG. 13K, n=12 each). These electrical measurements indicated that NpHR has little basal electrical activity or passive current-shunting ability and does not compromise cell health. The dynamic electrical properties of neurons were tested with and without NpHR.

[0131] There was no significant difference in the number of spikes evoked by 500 ms current injection of 300 pA ( $7.5 \pm 2.8$  for NpHR+ neurons,  $10.7 \pm 7.9$  for NpHR- neurons, and  $9.3 \pm 5.1$  for the light-exposed NpHR+ neurons; FIG. 13L).

[0132] To assess cell survivability, both live NpHR+ neurons (with and without light exposure) and NpHR- neurons were stained with the membrane-impermeant DNA-binding dye propidium iodide to assess cell survival. NpHR expression did not affect the percentage of neurons that took up propidium iodide (13/240 for NpHR+ cells, 7/141 for NpHR- cells, and 10/205 for the light-exposed NpHR+ cells; FIG. 13M,  $P > 0.999$  by  $X^2$  test). These experiments indicated that NpHR expression does not significantly affect the health or basal electrical properties of neurons.

[0133] The tunability of NpHR efficacy with different intensities of delivered light was measured using a 200 pA current step that drove reliable action potential trains. It was discovered that maximal light intensity of  $21.7 \text{ mW/mm}^2$  under a 40 $\times$ , 0.8 NA water-immersion objective inhibited  $98.2 \pm 3.7\%$  of the spikes.

[0134] FIGS. 14A and 14B show that using 33% or 50% of the full light intensity inhibited  $74.9 \pm 22.2\%$  and  $87.3 \pm 13.5\%$  of spikes, respectively. FIG. 14C shows that with steady current injection, lower intensities of light were effective for a shorter period of time; the delays from light onset to the first escaped spike under 33%, 50% and 100% light intensity were  $533.65 \pm 388.2 \text{ ms}$ ,  $757.5 \pm 235.5 \text{ ms}$ , and  $990.5 \pm 19.1 \text{ ms}$ , respectively. Therefore inhibition will be more effective early in the light pulse, presumably due to the slight inactivation of NpHR. Except where otherwise noted, the remaining experiments were conducted with  $21.7 \text{ mW/mm}^2$  yellow light delivered to the neurons.

[0135] Using trains of brief current pulses to generate spike trains, NpHR was tested for mediation of both long-term inhibition (to emulate lesions on the timescale of seconds to minutes) and short-term inhibition (to modify spike firing on the millisecond timescale). For long-term inhibition NpHR was tested over 10 min by injecting 300 pA current pulses at 5 Hz to drive steady action potential firing. Concurrent yellow light was delivered continuously for 10 minutes. NpHR-mediated inhibition of spike trains remained effective over many minutes as shown by FIG. 14D.  $99.0 \pm 1.9\%$  of spikes were inhibited within the first two minutes while over 90% of spikes were inhibited for up to 8 minutes as shown in FIG. 14E, with n=5. The slight decrease in efficacy is likely due to accumulation of non-functional NpHRs with a deprotonated Schiff base over long periods of light exposure. While natural reprotonation of the Schiff base is slow, any non-functional NpHRs can be readily and quickly restored via brief illumination with blue light as shown by FIG. 14F.

[0136] NpHR activation was tested for the ability to allow the “knockout” of single action potentials. The fast photocurrent of ChR2 enables brief pulses of blue light to drive reliable action potential trains. Concurrently applied brief

pulses of yellow light were used to test NpHR-mediated inhibition. FIG. 15A shows the results of an attempt to inhibit pairs of spikes in action potential trains of 5, 10, 20, and 30 Hz. Indeed, single spikes could be reliably inhibited from within longer spike trains. Several pairs of spikes within a range of inter-spike temporal delays were inhibited in an effort to define the temporal precision of NpHR. FIGS. 15A, 15B and 15C show that both closely timed and temporally separated spike pairs were able to be reliably inhibited, while sparing spikes between the targeted times (n=6). Over spike rates of 5 to 30 Hz, the closely timed spikes could be selectively inhibited with a probability of 0.95 or greater. Moreover, FIG. 15D shows that by giving trains of millisecond-scale yellow light pulses, it is straightforward to simulate barrages of IPSP-like events with precise, reliable timing and amplitudes, from 5 to 100 Hz.

[0137] Since NpHR is a Cl- pump and not a channel, the light-driven inhibition acts by shifting the membrane potential and will not contribute (significantly) to shunting or input resistance changes. FIGS. 15E and 15F show that, whereas the GABAA chloride channel agonist muscimol significantly decreased neuronal input resistance, NpHR activation had no detectable effect on the input resistance.

[0138] Since both ChR2 and NpHR can be activated with high temporal precision using millisecond-scale blue or yellow light pulses, an experiment was implemented to test the possibility of driving both proteins in intermingled temporally precise patterns. Such ability can be useful to noninvasively activate or inhibit single identified action potentials with light in the same experiment or even in the same cell. Cell attached and whole-cell recordings in hippocampal pyramidal neurons revealed that precisely patterned trains of yellow and blue light pulses can be used to evoke and inhibit neural activity with single spike precision, and that NpHR can be used to override multiple preselected ChR2-driven spikes at identified positions in prolonged spike trains.

[0139] Both NpHR and ChR2 can be functionally expressed in the mammalian brain without exogenous delivery of its required cofactor all-trans-retinal (ATR), presumably due to the presence of endogenous retinoids in the mammalian brain. As an experiment lentiviruses carrying NpHR-EYFP were delivered under the neuronal CaMKIIa promoter into the hippocampus of the adult mouse. Neurons throughout the hippocampus exhibited stable expression of NpHR-EYFP, as indicated by a robust EYFP fluorescence.

[0140] NpHR-EYFP cells in acute hippocampal slices exhibited voltage clamp photocurrents similar to those observed in cultured neurons. A current clamp recording of NpHR-EYFP neurons revealed that temporally precise patterns of spike inhibition could be achieved readily as in dissociated culture. No exogenous cofactors were delivered at any point, indicating that NpHR can be functionally applied to mammalian systems in vivo.

[0141] In another instance, NpHR/ChR2 system was combined in a system by expressing in living mammalian neural circuitry, with fura-2 calcium imaging in an all-optical experiment. Lentiviruses carrying ChR2-mCherry under the neuron-specific CaMKIIa promoter and NpHR-EYFP under the EF-1 promoter were injected into the brain of postnatal d4 mouse pups; acute cortical slices were prepared at postnatal d10-14 and labeled with fura-2-AM. In neurons co-expressing ChR2-mCherry and NpHR-EYFP, initial simultaneous illumination with both blue and yellow light did not lead to  $[\text{Ca}^{2+}]_i$  transients while subsequent pulsed

blue light alone in the same neurons evoked ChR2-triggered  $[Ca^{2+}]$  transients. This demonstrates that NpHR and ChR2 can be integrated to achieve multimodal, bidirectional control of neural activity in intact tissue. In the same imaged cells (where ChR2 stimulation led to a  $3.1 \pm 0.3\%$  increase in  $\Delta F/F$ ), the combination of NpHR and ChR2 activation resulted in a  $0.0 \pm 0.2\%$  effect on  $\Delta F/F$  ( $n=6$ ,  $P < 0.0001$ ). Yellow illumination alone had no detectable effect on  $[Ca^{2+}]$ . Since not all targeted cells are necessarily affected to the same degree, this optical system could complement electrophysiology to probe successful modulation of the targeted cell population. Thus, according to one embodiment, the combination of ChR2 and NpHR with calcium imaging provides an all-optical system for interrogation of neural circuits.

**[0142]** Another set of experiments were conducted to show control of animal behavior in vivo. An in vivo experiment involved expression of NpHR-ECFP fusion protein in the body wall muscles of the nematode *Caenorhabditis elegans* using the muscle-specific myosin promoter (Pmyo-3). ECFP fluorescence could be readily observed throughout muscle cells and membranous muscle arm extensions. As worms (unlike mammals) appear not to have sufficient levels of endogenous retinoids<sup>7</sup>, transgenic animals expressing NpHR in muscle were grown in medium containing ATR. Whole-cell voltage-clamp recordings from dissected muscles indeed demonstrated light-evoked outward currents ( $265 \pm 82$  pA,  $n=9$ ). To test effects on muscle activity, swimming behavior in liquid medium was analyzed. Consistent with the photocurrents observed, photoactivation of NpHR immediately (within  $\sim 150$  ms) and essentially completely arrested swimming behavior. Transgenic animals raised in the absence of ATR, and wild type animals raised with and without ATR were used as controls. Robust paralyzing effects of light were observed, but consistently only in transgenic animals raised in the presence of ATR.

**[0143]** When muscle-expressing animals were illuminated for 1 second, they quickly returned to their natural swimming rate after light stimulus termination. When NpHR was activated in muscle for 10 seconds, animals remained uncoordinated for prolonged periods (up to 40 seconds), before a full recovery became apparent and normal swimming commenced.

**[0144]** Another experiment involved targeting of NpHR to a specific class of genetically defined neurons in vivo. NpHR-ECFP was expressed in cholinergic motoneurons using the vesicular acetylcholine transporter promoter (Punc-17). When illuminated for 1 or 10 seconds, respectively, these animals also strongly reduced or essentially stopped swimming behavior as shown by. These animals, in contrast to the muscle targeted individuals, recovered to normal swimming behavior immediately, perhaps indicating more powerful Cl<sup>-</sup> homeostasis in neurons than in muscles, although in all cases full recovery was observed consistent with the lack of toxicity observed in mammalian neurons. When illuminated on solid agar substrate, transgenic animals expressing NpHR either in muscle, or in cholinergic motoneurons, exhibited rapid inhibition of movement and relaxed their bodies, resulting in overall elongation by up to 9% within  $\sim 600$  ms of illumination.

**[0145]** ChR2 and NpHR was found to be able to be driven simultaneously in *C. elegans*. With either muscle or targeted cholinergic neuron expression (using the Pmyo-3 or Punc-17 promoters, respectively), NpHR rapidly and reversibly

counteracted the shortening behavior observed with ChR2 alone. These experiments demonstrate that acetylcholine release can be efficiently triggered from *C. elegans* motoneurons using ChR2, and that ChR2 and NpHR work well together in nematodes as well as mammals. In some instances, such an NpHR/ChR2 system enables rapid bidirectional control of neurons on the timescale of milliseconds, thus enabling emulation or alteration of the neural code. These fast genetically based neural spike-controlling technologies powerfully augment existing tools for interrogating neural systems. Indeed, integration of the NpHR/ChR2 neural control system with optical activity markers like fura-2, and with GFP-based morphological markers, delivers a versatile triad of technologies for watching, listening to, and controlling living neural circuitry with light.

**[0146]** Both NpHR and ChR2 can be functionally expressed and operate at high speed in the mammalian brain without necessitating cofactor addition. Moreover, NpHR and ChR2 function in behaving *C. elegans* as well after simple dietary ATR supplementation. When combined with optical imaging or behavioral measures in intact tissue or freely moving animals, the NpHR/ChR2 system provides the capability to directly and causally link precisely defined patterns of neural activity with specific circuit behaviors.

**[0147]** The ability to use light to inhibit or activate neurons has practical applications beyond basic science investigations. The NpHR/ChR2 system may be genetically targeted to specific classes of neurons or other excitable cells involved in disease processes to enable highly precise optical therapeutic treatments. For example, in Parkinson's disease where electrode-based deep brain stimulation (DBS) can be therapeutic for symptomatic relief but also gives rise to side effects, delivery of these optogenetic tools targeted by cell type-specific promoters to distinct disease-related neuronal types may ultimately provide a more precise alternative with fewer side-effects. Whether in basic science or clinical applications, the spectral separation between the NpHR and ChR2 activation maxima allows for the first time bidirectional optical control in the same target tissue, and permits both sufficiency and necessity testing in elucidation of the roles of specific cell types in high-speed intact circuit function.

**[0148]** FIG. 16 depicts an arrangement with multiple light sources, according to an example embodiment of the present invention. FIG. 16 shows light sources 1602 and 1604 that illuminate proteins 1610 and 1614. The proteins 1610 and 1614 are engineered within cell 1612 to control current across the cell membrane in response to light from light sources 1602 and 1604, respectively. In one instance, the first protein 1610 functions to dissuade action potential firing, while the second protein 1614 functions to encourage action potential firing. Each of proteins 1610 and 1614 are responsive to light. In a particular instance, the first protein is responsive to light from light source 1602 having a wavelength A and the second protein is responsive to light from light source 1604 having a wavelength B. Thus, the light sources can be used to control each protein independently. This can be useful for both encouraging and dissuading action potentials in the cell. In another instance, having both types of proteins allows for both positive and negative control of the cell membrane voltage. Thus, the different light sources and proteins could be used to control the voltage or current level (e.g., clamping) of the cell membrane.

[0149] One method of determining responsiveness involves quantifying the responsiveness in terms of the intensity of light required to produce a given response. In some instances, the first or second protein can still be responsive to the alternate wavelength of light although the responsiveness of the protein may be less than that of the primary wavelength. Accordingly, a protein of a first type may have some responsiveness to the wavelength corresponding to the other type of protein while still maintaining sufficient independence of operation. In one such instance, control of the cell can be implemented by shifting either the wavelength of light or the intensity of the light. For instance, the wavelength can be shifted between A and B to induce a corresponding increase or decrease the membrane voltage potential.

[0150] Embodiments of the invention can be implemented with just the protein based ion pump(s). In a specific example, pump **1610** is designed to operate using an endogenous cofactor, such as ATR, which can be found in people and many animals. This is particularly useful for minimizing intrusiveness of in vivo applications because it can reduce the need for foreign substances (e.g., cofactors). In a particular instance, pump is a halorhodopsin that acts as an anion pump (e.g.,  $\text{Cl}^-$ ) that is activated in response to light from light source **1602** within milliseconds. Such a fast response allows for the system to control (dissuade) individual action potentials in the cell.

[0151] According to one embodiment of the present invention, pump **1614** can optionally be implemented for purposes other than dissuading action potential firing, such as controlling the voltage level of cell **1608**. More specifically, a sensor can be used provide feedback to the light source **1602**. For instance, this feedback could be a measurement of the voltage or current across the cell membrane. Thus, the light source could be configured to maintain a constant current or voltage (e.g., clamp) across the cell. Moreover, the amount of responsiveness can be controlled by modifying one or more of the intensity and wavelength of the light.

[0152] FIG. 17 shows a system for controlling electrical properties of one or more cells in vivo, according to an example embodiment of the present invention. Control/Interface unit **1702** enables/disables light source **1704** to illuminate target cells **1708**. A delivery mechanism, such as fiber optic cable **1706**, routes or otherwise directs the light to target cells **1708**. Fiber optic cable **1706** may include a bundle of optical cables, each capable of carrying and directing light independently. Thus, fiber optic cable **1706** can be configured to deliver light having one or more wavelengths to multiple locations. Sensor **1710** can be implemented e.g., as an optical device such as an optical scope or as a voltmeter, to provide feedback to control unit **1702**. In a particular instance, the feedback includes optical imaging of the target cells or of other related cells. In another instance, the feedback could monitor the voltage response of the target cells, including the amount of action potential firing.

[0153] FIG. 18 shows a system for controlling electrical properties of one or more cells in vivo, according to an example embodiment of the present invention. Control/Interface unit **1802** enables/disables implantable light source **1804**, which in turn illuminates target cells **1806**. Light source **1804** is shown with two light source, inhibitory current light source **1808** and excitation current light source **1810**. Light source **1808** produces light at a wavelength and

intensity that an inhibitory protein is responsive to, while light source **1810** produces light at a wavelength and intensity that an excitation protein is responsive to. One skilled in the art would recognize that various configurations of light source **1810** are possible, including a single inhibitory light source or an array of light sources having one or more wavelengths. Control/Interface unit **1802** communicates with light source **1804** through any suitable communication mechanisms, such as wired communications or wireless communications using radio-frequency signals, magnetic signals and the like. As discussed above in connection with FIG. 17, sensor **1812** can optionally be implemented for providing feedback to control unit **1802**.

#### Drug Screening

[0154] The various light-sensitive proteins, serving to regulate membrane voltage using ion switches that, when activated (or deactivated) in response to light, function as channels or pumps, are referred to hereafter as light-responsive ion switches or light-activated membrane potential switches (LAMPS).

[0155] Consistent with one example embodiment of the present invention, a system screens for ion-channel and ion-pump affecting compounds. The system introduces one or more drug candidates that could either block or enhance the activity of ion-channels or ion-pumps to cells that were made optically responsive by the addition of the above mentioned proteins (ChR2 and NpHR), for the purpose of screening the drug candidates. Light triggers optically responsive ion channels in the cells causing a change in the voltage seen across the cell membrane. The voltage change stimulates voltage-gated ion channels in the cells which will then cause a change in ion concentrations that can be read as optical outputs. These optical signals are detected and used to determine what effect, if any, the drug candidates have on the voltage-gated ion channels.

[0156] In one instance, the system allows for different drug candidates to be screened without necessitating extensive setup between screenings. For example, an assay may be performed using optics both to stimulate the optically responsive cells and to detect the effectiveness of the drug. The use of optics instead of manual contacts, e.g., using a whole-cell patch clamp, can be particularly useful in increasing the throughput of the assay screening process. For instance, the time between screenings can be reduced by minimizing or eliminating physical manipulations otherwise necessary to stimulate or detect ion flow in the target cells. The cells can also be prepared prior to the screening process because the test equipment need only be optically coupled to the prepared cells. In another instance, throughput may be increased by screening a number of different drugs simultaneously using, for example, an array of photo detectors and a corresponding array of modified cells exposed to different drugs.

[0157] Consistent with another embodiment of the present invention, an optically-responsive cell line is created to screen for drugs that affect the functionality of ion channels. The cell line includes cells that co-express optically responsive ion switches of Channelrhodopsin-2 (ChR2) or NpHR, a voltage-gated  $\text{Ca}^{2+}$  channel and a hyperpolarizing channel/pump (e.g., hERG or TASK1, that can lower the membrane voltage to a point where the voltage-gated  $\text{Ca}^{2+}$  channel will be in a closed state). The system measures the concentration of  $\text{Ca}^{2+}$  using an indicator dye (e.g., Fura-2)



or genetically encoded activity sensor. The above mentioned components are introduced to the cell line by standard liposomal transfection methods and the ChR2 related channel is stimulated using (blue) light; for further information in the regard, reference may be made to the patent documents cited herein to the articles cited supra. Time lapse images of light from the Ca<sup>2+</sup> sensitive portion of the system are taken and stored as data. A processor analyzes the data to identify potential channel-affecting drugs. For instance, the processor may identify all chemicals that have concentrations of Ca<sup>2+</sup> that do not fall within expected parameters (e.g., concentrations that exceed or are less than an expected range of concentrations).

**[0158]** In a specific instance, the cell line is derived from 293T cells by co-expressing ChR2 and a voltage-gated Ca<sup>2+</sup> channel. The 293T cells (and 293T cell line) are a variant of Human Embryonic Kidney (HEK) cells that include the Simian vacuolating virus 40 (SV40) T antigen (see, e.g., N. Louis, C. Eveleigh, F. L. Graham, *Cloning and sequencing of the cellular-viral junctions from the human adenovirus type 5 transformed 293 cell line*, *Virology*, 233(2):423-9, Jul. 7, 1997). Expression of the light-responsive ion channels, the voltage-gated ion channels and the hyperpolarizing channels by the 293T cells may be accomplished using appropriate transfection vectors.

**[0159]** More specifically, the cell lines may be derived from a stable homogeneous cell line such as HEK293, NIH3T3, or CHO. Several genes responsible for making different subunits of calcium channels have been introduced into the cell lines to provide functional calcium channel activity. In addition to the calcium channel genes, an inward-rectifying potassium channel may be expressed to mimic the natural state of calcium channels by maintaining a more hyperpolarized membrane potential (compared to the default resting membrane potential of HEK293, NIH3T3, or CHO cell lines). Also, a light-activated cation channel channel-rhodopsin-2 (ChR2) may be expressed to facilitate optical depolarization and subsequent activation of the calcium channels. Another option includes the expression of a light-activated chloride pump *Natronomonas pharonis* halorhodopsin (NpHR) to enable rapid optical hyperpolarization of the cell membrane potential.

**[0160]** This cell line based approach is not limited to voltage-gated calcium channels. For example, similar cell lines can be created for voltage-gated sodium (e.g., Na<sub>v</sub> 1.1 through Na<sub>v</sub>1.9), potassium (e.g., K<sub>v</sub> such as hERG, TASK1, Shaker, or KvLQT1), or chloride conducting channels/pumps (e.g., members of the CLC family of chloride channels). The methods of introducing such genes into the cell line are known in the art and may include, for example liposomal transfection, or viral gene transfer. For further information in this regard, reference may be made to one or more of the following references:

**[0161]** Warren Pear, *Transient Transfection Methods for Preparation of High-Titer Retroviral Supernatants*, Supplement 68, *Current Protocols in Molecular Biology*, 9.11.1-9.11.18, John Wiley & Sons, Inc. (1996).

**[0162]** R. E. Kingston, C. A. Chen, H. Okayama, and J. K. Rose, *Transfection of DNA into Eukaryotic Cells*, Supplement 63, *Current Protocols in Molecular Biology*, 9.1.1-9.1.11, John Wiley & Sons, Inc. (1996).

**[0163]** R. Mortensen, J. D. Chesnut, J. P. Hoeffler, and R. E. Kingston, *Selection of Transfected Mammalian Cells*,

*Supplement 62, Current Protocols in Molecular Biology*, 9.5.1-9.5.19, John Wiley & Sons, Inc. (1997).

**[0164]** H. Potter, *Transfection by Electroporation*, Supplement 62, *Current Protocols in Molecular Biology*, 9.3.1-9.3.6, John Wiley & Sons, Inc. (1996).

**[0165]** T. Gulick, *Transfection using DEAE-Dextran*, Supplement 40, *Current Protocols in Molecular Biology*, 9.2.1-9.2.10, John Wiley & Sons, Inc. (1997).

**[0166]** R. E. Kingston, C. A. Chen, H. Okayama, *Transfection and Expression of Cloned DNA*, Supplement 31, *Current Protocols in Immunology (CPI)*, 10.13.1-10.13.9, John Wiley & Sons, Inc.

Each of the above references is incorporated by reference in its entirety.

**[0167]** These and other transfer vectors may be generated using various genetic engineering techniques. For instance, the transfer vectors may be derived from a provirus clone of a retrovirus, such as an immunodeficiency virus (e.g., HIV-1 or HIV-2, or SIV). For further details on the use of 293T cells and transfection thereof, reference can be made to U.S. Pat. No. 6,790,657 (entitled, Lentivirus Vector System, to Arya), which is fully incorporated herein by reference.

**[0168]** In one embodiment of the invention, optical stimulation of the modified cells may be altered to determine specific properties of an introduced drug candidate. For example, the intensity of the optical stimulus may be modified to change the corresponding level of depolarization. The level of desired depolarization can be tuned to further characterize the effectiveness of the drug under test. In another example, the optical stimulus may include rapid pulsing of the light. By correlating the temporal relationship between the optical stimulus and the resultant detected fluorescence, the drug may be further characterized in terms of a kinetic response. Thus, the drug may be characterized for a variety of different aspects including, but not limited to, the steady state effect on ion concentrations, a change in the level of depolarization necessary to trigger the voltage gated ion channels and the effect on repeated depolarization.

**[0169]** In one embodiment, the system allows for simple calibration of the optical stimulation and/or detection. The modified cells may be optically stimulated prior to introduction of the drug candidate. The ion channel responsiveness is detected and recorded. The recorded values may be used as a baseline for comparison to the ion channel responsiveness of the same modified cells after the introduction of the drug under test. The recorded values may also be used to modify the optical stimulus or the sensitivity of the optical detector. Such modifications may be applied to an individual test sample or an array of test samples. For such an array of test samples, each test sample may be individually calibrated by adjusting the corresponding optical stimulus. Similarly, each corresponding photo detector may be individually adjusted.

**[0170]** FIG. 19A shows a basic block diagram of a system for screening for ion-channel affecting drugs, according to an embodiment of the invention. Optical control 1904 communicates with database 1902, optical source 1906 and optical detector 1909. Optical source 1906 provides optical stimulus to test sample 1908. Test sample 1908 includes the drug under test, cells with optically responsive ion channels, and a voltage/ion indicator. In one instance, the indicator fluoresces in response to light from optical source 1906. Optical control 1904 may also include a reconfigurable readout, so that as different LAMPS and different LEIAs are

used, the same control system can be readily adapted to each paradigm. Optical detector **1909** produces a signal responsive to such fluorescence, and optical control **1904** receives the produced signal. The optical control **1904** stores data obtained from the signal in database **1902**. The information stored may include factors such as the intensity, duration and wavelength of the detected light. In a particular instance, the stored data can be compared against baseline data, where the baseline data corresponds to data recorded prior to the introduction of the drug to the test sample **1908**. In another instance, optical source **1906** may vary the intensity, duration or other parameters related to the control of optical source **1906**. These and other parameters may be stored in database **1902**.

[0171] It should be apparent that optical source **1906** may be implemented using a single light source, such as a light-emitting diode (LED), or using several light sources. Similarly, optical detector **1909** may use one or more detectors and database **1902** may be implemented using any number of suitable storage devices.

[0172] FIG. **19B** shows a system diagram of a large-format, quasi-automated system for drug screening in accordance with a specific embodiment of the invention. Control device **1901** (e.g., a computer or control logic) controls various processes, and serves as the central point of system input/output functions. The environment may be maintained at an appropriate temperature, humidity, carbon dioxide level and ambient light level within the walls of the climate control chamber **1905**, with the help of one or more sensors **1914** (e.g., thermostat, carbon dioxide sensor and humidity sensor), carbon dioxide and humidifier apparatus **1912**, and heater **1910**. Multi-well tray **1941** contains test wells **1940** for holding cultured cells, drugs, and other ingredients needed for each test. Tray **1941** rests upon X-Y-Z table **1925**, the movement of which is carried out by table actuators **1920**, under control of computer **1901**. Xenon lamp **1955** emits high-intensity white light **1956**, which is passed through color filter **1960**. In the case that ChR2 is used for stimulating the cells within wells **1940**, color filter **1960** is blue, causing blue light **1961** to exit the filter, and strike dichroic mirror **1970**. Blue light **1961** then passes upward, through microscope objective lens apparatus **1930**, and through bottom of transparent tray **1941**. In this fashion, the contents of wells **1940**, with their transparent undersides, are illuminated. When a separate wavelength of light is required to stimulate a fluorescent light-emitting indicator of cellular activity, a filter of the appropriate specification may be substituted for the previous filter **160**, causing light of the proper wavelength for this latter task to be piped toward well **1940**. If the cells within well **1940** have been light-sensitized, and if the drug being tested in each of these wells does not suppress the process, a light-emitting indicator of cellular activity (LEIA), which has also been added to each well or expressed by the cells via genetic modification, will emit light in accordance with the voltage change caused by the effect of the light. This second wavelength of light, which may be much smaller in magnitude than the stimulation light, is collected by microscope turret **1935**, and will also be passed through dichroic mirror **1975**, onto the lens of (CCD) camera **1980**.

[0173] Dichroic mirror **1970** allows for upward reflection of both the wavelength required to stimulate the optical gating of the membrane (e.g., blue for ChR2), and the wavelength required by any LEIA used (e.g., ultraviolet for

FURA-2). This dichroic mirror may be arranged to allow passage of the output spectrum of the LEIA (e.g., blue-green for FURA-2) with minimal reflection or absorption.

[0174] FIG. **20** is a system diagram of an automated-drug-screening system, according to an example embodiment of the invention. Emitter/detector units **2050** make up the emitter/detector array **2051**. Emitter/detector array **2051** matches the number, size, and layout of the wells on tray **2040**. Tray holding device **2025** permits tray swapping mechanism **2020** to rapidly move a new tray into position once testing of a given tray has been completed. The entire process may be automated, and under the control of device **2001**. Device **2001** can be implemented using a computer, control logic, programmable logic arrays, discrete logic and the like. The introduction of the drug candidates under test can also be automated using a machine that provides a reservoir for storing the drugs and a dispensing nozzle for injecting the drugs into the tray. In a manner similar to that shown by FIG. **19**, the environment within the walls of the climate control chamber **2005** may be maintained at an appropriate temperature, humidity, carbon dioxide level and ambient light level, with the help of thermostat, carbon dioxide sensor and humidity sensor **2014**, carbon dioxide and humidifier apparatus **2012**, and heater **2010**. The use of multiple stimulator/detector elements simultaneously and in parallel, can be particularly useful for augmenting the speed of the overall process. Low cost elements may be used to make multiple parallel detectors (e.g., the components detailed below in description of FIGS. **21A** and **21B**), the multiple parallel emitter/detector units may also be quite economically feasible.

[0175] FIG. **21A** depicts the workings of emitter/detector units, such as those shown in FIG. **20**, according to an example embodiment of the invention. An LED stimulates light-sensitive ion channels of cells located within a well, and a photodiode detects the response of a LEIA. In this embodiment, device **2101** includes LED **2110**, which produces light pulses **2111**, at the proper wavelength, pulse frequency and intensity, so as to stimulate light-sensitive transgenic cells **2105** in culture within well **2106**. In the case that ChR2 is the molecular target being used, blue light of 1-10 mW/mm<sup>2</sup> is generally appropriate. Due to the presence of an LEIA (e.g., a voltage-sensitive dye or a calcium dye), light **2116** is returned from cells **2105**, and is detected by photodiode **2115**. In the case that RH 1691 being used, red light is fluoresced and detected by photodiode **2115**. In the absence of cellular depolarization, no fluorescence is detected by photodiode **2115**. Other light detecting technologies may also be used instead of a photodiode including phototransistors, and CCD elements.

[0176] The combination of photostimulation with optical imaging techniques of LEIAs may be useful for a number of different reasons. For example, photostimulation may simplify the study of excitable cells by reducing the need to use mechanical electrodes for stimulation. Several commercially available LEIAs are suitable for photogrammetrically indicating the activation of electrically excitable cells. One such LEIA is calcium dye Fura-2, which may be stimulated with violet/ultraviolet light around 340 nm, and whose fluorescent output is detectable as blue-green light around 535 nm. Another example is voltage sensitive dye RH 1691, which may be stimulated with green light at about 550 nm, and whose fluorescent output is detectable as red light at about 70 nm. Another example is voltage sensitive dye

di-4-ANEPPS, which is stimulated by blue light at about 560 nm, and whose fluorescent output is detectable as red light at about 640 nm.

[0177] FIG. 21B depicts the workings of another embodiment of the emitter/detector units shown in the FIG. 20, in which multiple effects are tested within the context of a single well. For example, the cells 2155 in the wells 2156 may express both ChR2 and NpHR, and hence be sensitive to both the depolarizing effects of blue light, and the hyperpolarizing effects of amber light. Device 2151 includes LED 2160, which is used for the stimulation of the targeted ion channel or pump (e.g., ChR2) of light-sensitive transgenic cells 2155. Additional LED 2175 may be used to stimulate a second targeted ion channel or pump (e.g., NpHR). Yet another LED 2180 may be used to stimulate a voltage sensitive dye (e.g., RH1691 or calcium dye, such as Fura-2). Each LED may be arranged to output specific wavelengths and intensities for stimulus of respective targeted compounds. In one instance, an LED may affect more than one target, depending upon the specific sensitivities of each compound used. Photodiode 2165 detects the fluorescence of a selected voltage dye, while photodiode 2170 is sensitive to the spectrum fluoresced by a selected calcium dye. The use of multiple LEDs for the same cell allows for the stimulation of LEIAs at different wavelengths. Multiple LEDs may also be used to detect different light wavelengths emitted by the LEIA.

[0178] FIG. 22A depicts an electronic circuit mechanism for activating the LED emitters used within the emitter/detector units, according to an example embodiment of the invention. Control device 2201 generates a “light on signal” 2202 to transistor base 2205. This “light on signal” 402 will remain on for the duration of a light flash desired, or alternatively may turn on and off in order to produce rhythmic light flashes at a specified frequency. Light on signal 2202 permits (conventional) current to flow from power source 2210, through resistor 2211, and through transistor collector 2207 and transistor emitter 2212, to ground 2213. Current is also thereby permitted to pass through resistor 2215, and into LED 2220. LED 2220 emits light 2221, which falls upon well 2225. In a particular instance, the transistor functions as transconductance amplifier of signal 2202. In this manner, light of the appropriate wavelength, intensity and frequency is delivered to cells within the well 2225, so as to cause them to stimulate the particular ion channel (e.g., ChR2) or pump (e.g., NpHR), or other photoactive membrane structure being used to regulate the activity of electrically excitable cells. Various other circuits are also possible. For example, other circuits can be used in place of circuit 2206 to control LED 2220 including, but not limited to, replacing the transistor with an operational amplifier, a field-effect-transistor, a resistor divider network, transistor-transistor logic, push-pull driver circuits and switches.

[0179] FIG. 22B depicts an example electronic circuit mechanism for light detection by the emitter/detector units, according to one embodiment of the invention. Control device 2250 may (optionally, depending upon specific implementation) provide power to photodiode 2255. Photodiode 2255 receives fluoresced (emitted) light 2256 from the LEIA on the cells within well 2257. The received light results in an output signal. This output passes through resistor 2260, and is input to Schmitt triggered hex inverter

2270, which conditions the signal, providing a clean “high” or “low value” to be input to computer 2250.

[0180] Operation of the photodetector is shown in photo-voltaic mode, but the element may also be used in the photoconductive mode of operation. Of course, many other light-detection devices and methods may also be used, including phototransistors, photothyristors, and charged-coupled device (CCD) elements, or arrays of elements.

[0181] Alternatively, the 22B circuit can be used without Schmitt-triggered hex inverter 2270, permitting a continuum of signal intensities to be transmitted directly to an analog input to computer 2250 or to an analog-to-digital converter. Various other signal conditioning circuits are also possible.

[0182] FIG. 23 shows a sequence of steps using the embodiment shown in FIGS. 20, 21 and 22, in the context of projected high-throughput process time course 2300 and in accordance with one embodiment of the invention. In step 2305, light of the appropriate wavelength and intensity for the targeted ion channel is flashed—in this case for approximately 3 seconds. Concurrently, a LEIA stimulation flash 2310 may optionally be triggered, depending upon the specific voltage or calcium dye, etc. being used. This LEIA compound may have been previously added to the well, or may be (artificially) genetically imparted upon the cells such that the chemical is produced/expressed by the cells. In step 2315, the light signal produced by the LEIA is detected by the photodetector element (e.g., photodiode). For example, RH1691, fluoresces red light at about 70 nm.

[0183] In step 2320, the signal resulting from the impingement of light onto the photodetector element is sent back to the computer. This may be a binary (e.g., “high” versus “low” signal intensity), or may be graded to reflect a continuum of activation levels. In the case that multiple photodetectors are used to determine energies at different wavelengths, the individual readings of these photodetectors may be logged in parallel or in sequence for appropriate interpretation in a later stage of the automated process. In step 2330, the system calls for the next tray to be placed by the automated system. The next tray is moved into position at step 2335 and the process may be repeated until all trays in a batch have been processed.

[0184] The level of light fluoresced is typically much lower than that required to optically stimulate a cell via light-sensitive ion channels or pumps. For example, ChR2 may require blue light of 1-10 mW/mm<sup>2</sup> or more in order to robustly depolarize cells. RH 1691 may require approximately 0.1 mW/mm<sup>2</sup> to stimulate it. Given that RH1691 shows significant sensitivity to blue light, (peak sensitivity is at the blue-green wavelengths), RH1691 is adequately stimulated by the same pulse used to stimulate ChR2, but emits light upon depolarization at a power of only on the order of 0.001 mW/mm<sup>2</sup>. This small amount of output light would be difficult to distinguish from the comparatively massive blue pulse used to stimulate ChR2, even if efficient filters were used in front of the detectors. Fortunately, temporal differences between the ChR2 stimulation (with simultaneous LEIA stimulation), and the fluorescent output of depolarized cells can be used to distinguish the light sources. For instance, the dye-based fluorescence may continue for a few seconds after the delivery of the depolarization pulse and the resultant action potential. Thus in some instances, such as a non-fluorescent LEIA or a luminescent activity dye, a separate stimulation flash is not required.

**[0185]** The amount of time allotted for light delivery may vary, and depends on factors including the level of light-gated ion channel/pump expression, and the density and characteristics of other ionic channel characteristics of that cell population. The amount of time allotted for light receipt may vary, and depends upon factors including the degree of accuracy required for the screening session. The amount of time allotted for well-plate (tray) changing may vary, and depends upon factors including the mechanical speed of the automated apparatus. If fast neurons are used as the cells being tested, the cellular stimulation and LEIA detection process may be accomplished in milliseconds.

**[0186]** In an example process, a 293T cell line expressing TASK-1 (to simulate the natural hyperpolarized membrane potential of neurons), ChR2 (to induce depolarization of the cell membrane), and the L-type calcium channel are used. Whole-cell patch clamping experiments show that the membrane of the modified 293T cell line is hyperpolarized to the point where the L-type calcium channels are closed. The cells are stimulated for 5 seconds with continuous blue light (470 nm) to activate ChR2. ChR2-mediated depolarization opens the co-expressed voltage-gated calcium channels. Upon ChR2 illumination, a strong calcium influx is recorded using a genetically-encoded calcium dye indicator, which fluoresced light with cellular depolarization. Nimodopine, a well-known L-type calcium channel blocker, abolishes the calcium influx- and hence the fluoresced signal when applied to the cells for 10 minutes. This data demonstrates the effectiveness of the system described herein.

**[0187]** The process above may be repeated under varying conditions. For example, a given set of cells may be tested with no drug present, and subsequently with one or more drugs present. The response of electrically-excitabile cells under those conditions may be thereby documented, compared and studied. If the invention is implemented with at least one emitter/detector for each well on a tray and at least two concurrently operating devices, continuous operation may be maintained for extended periods of time.

**[0188]** FIG. 24 illustrates an example of a layout of cell and drug samples within the wells of a well-plate which is suitable for use within an embodiment of the invention. In this figure, well-plate 2401 (also referred to herein as a "tray" contains wells 2405 (examples), which are organized into columns 2425, labeled with numbers 1-12 and rows 2420, labeled with letters A-H. More specifically, an example column and row are defined by 2410 and 2415 respectively.

**[0189]** As an example of a functional layout of contents introduced into these wells, rows A-H of a single plate might be used for the testing of two different drugs. To represent a baseline condition, column 1 might contain optically gated cells, an endogenous or exogenous LEIA, but no drug. Columns 2-6 might be used for five different concentrations of Drug X, one concentration level per column. Likewise, columns 7-11 might be use for five different concentrations of Drug Y, one concentration per column. Column 12, while fully usable, is left unused in this particular example.

**[0190]** Variables in the various wells might include the type of cell being tested, the type of ion channel being tested for, the type of drug placed in the cell, the concentration of the drug placed in the well, the specific LEIA used, and the optical gating stimulation parameters (e.g., wavelength, intensity, frequency, duration) applied to the cells in that well.

**[0191]** FIG. 25 illustrates the context in which the disclosed invention may be employed within a larger system which facilitates high-throughput drug screening. Well-plate 2506 contains wells 2505. These are carried forward by conveyer 2520, which may be a device such as a conveyor belt, robotic transporter or other delivery mechanism. Pipettes 2510 are held in array by robotic member 2515, and serve to inject the proper number of cultured cells and media into wells 2505. Subsequently, well-plate 2506 is moved down conveyer 2520, where robotic member 2525, analogous to robotic member 2515 and also containing pipettes, injects the proper amount of a LEIA into wells 2505. Conveyer 2520 then brings well-plate 2505 into screening chamber 2530. An emitter/detector apparatus, such as those described in connection with FIG. 20, FIG. 21A, FIG. 21B, FIG. 22A, and

**[0192]** FIG. 22B, is located within chamber 2530. Additionally, portions of the processes described in FIG. 23 may occur within this chamber. Subsequently, well-plates 2535 is moved out of screening chamber 2530 by conveyer 2540, and discarded at 2545. In an alternative embodiment, one or more robotic devices may move pipettes 2510, screening chamber 2530, etc. to the locations of well-plate 2506, rather than vice-versa.

**[0193]** Consistent with the above discussion, example screening methods could include the collection of multiple data points without having to switch samples. Because control over the samples is reversible in the same sample preparation by simply turning the activating light on and off with fast shutters, the same samples can be reused. Further, a range of patterns of stimulation can be provided to the same cell sample so that testing can be performed for the effect of drugs without concern with regards to differences across different sample preparations. By modulating the level of excitation (e.g., by ramping the level from no light to a high or maximum intensity), the effect of the drug across a range of membrane potentials can be tested. This permits for the identification of drugs that are efficacious during hyperpolarized, natural, or depolarized membrane potentials.

**[0194]** The cell lines described herein may be a particularly useful for detailed characterization of drug candidates in a high-throughput manner. Optical control is relatively fast, thereby allowing for the testing the drug's activity under more physiological forms of activation. For example, different frequencies of depolarization and/or hyperpolarization may be used to determine how a drug interacts with the channel under physiological forms of neural activity. In some instances, the process may be accomplished without the application of expensive chemical dyes to the cell lines.

**[0195]** In conjunction with the various properties discussed herein, the use of various embodiments of the invention may be particularly useful for improving screening throughput by eliminating the need for cumbersome mechanical manipulation and liquid handling. Various embodiments may also be useful for repeatable the screening assay using the same samples, reducing screening cost by eliminating the need for chemically-based fluorescence reports, producing high temporal precision and low signal artifact (due to the optical nature of the voltage manipulation), modulating the level of depolarization by attenuating the light intensity used for stimulation, and ascertaining the kinetics of the drug's modulation on the ion channel through the use of pulsed light patterns.

**[0196]** The various embodiments described above are provided by way of illustration only and should not be construed to limit the invention. Based on the above discussion and illustrations, those skilled in the art will readily recognize that various modifications and changes may be made to the present invention without strictly following the exemplary embodiments and applications illustrated and described herein. For instance, such changes may include the use of digital logic or microprocessors to control the emitted light. Such modifications and changes do not depart from the true spirit and scope of the present invention, which is set forth in the following claims.

What is claimed is:

**1.** A method for generating an inhibitory-current flow in neurons, the method comprising:

in a neuron, engineering an inhibitory protein that responds to light by producing an inhibitory current to dissuade depolarization of the neuron, wherein the inhibitory protein uses an endogenous cofactor to produce the inhibitory current.

**2.** The method of claim **1**, wherein the inhibitory protein is an anion pump that includes a halorhodopsin derived from one of *Halobacterium salinarum* and *Natronomonas pharaonis*.

**3.** The method of claim **1**, the method further includes the step of, in the neuron, engineering an excitation protein that responds to light by producing an excitation current to encourage depolarization of the neuron.

**4.** The method of claim **3**, wherein the inhibitory protein has a first excitation wavelength maxima and the excitation protein has a second excitation wavelength maxima that is different from the first excitation wavelength maxima.

**5.** The method of claim **4**, further including the steps of controlling a first light source to produce a series of optical pulses each having a duration sufficient to induce individual depolarization events and controlling a second light source to produce a series of optical pulses each having a duration sufficient to dissuade individual depolarization events.

**6.** The method of claim **5**, wherein the inhibitory protein includes halorhodopsin and the excitation protein includes channelrhodopsin, wherein the first light source is operated near the first excitation wavelength maxima, and wherein the second light source is operated near the second excitation wavelength maxima.

**7.** The method of claim **3**, wherein the inhibitory current includes chloride ions and the excitation current includes sodium ions.

**8.** The method of claim **1**, wherein the step of engineering includes at least one of: transduction of the neuron using a viral vector containing a halorhodopsin protein, transfection of the neuron, microinjection of DNA into the neuron, and genetically targeting the inhibitory protein to specific classes of neurons.

**9.** The method of claim **1**, wherein the inhibitory current substantially dissuades depolarization of the neuron in less than 500 milliseconds after introduction of light.

**10.** The method of claim **1**, further including the steps of introducing light to the protein to produce the inhibitory current, measuring a resulting ion concentration in the neuron using an optical sensor.

**11.** The method of claim **1**, wherein the inhibitory protein uses all-trans-retinal as a cofactor.

**12.** The method of claim **1**, wherein the inhibitory protein includes halorhodopsin derived from one of *Halobacterium salinarum* and *Natronomonas pharaonis*.

**13.** A method for controlling action potential of a neuron, the method comprising:

engineering a first light responsive protein in the neuron; producing, in response to light, an inhibitory current in the neuron from the first light responsive protein;

engineering a second light responsive protein in the neuron; and

producing, in response to light, an excitation current in the neuron from the second light responsive protein.

**14.** The method of claim **13**, wherein the first light responsive protein has a first excitation wavelength maxima and the second light responsive protein has a second excitation wavelength maxima that is different from the first excitation wavelength maxima

**15.** The method of claim **14**, further including the steps of controlling individual action potentials in an action potential train using light pulses sufficiently near the first and second excitation wavelength maxima to produce the inhibitory current and the excitation current, respectively.

**16.** The method of claim **15**, wherein the light pulses have a frequency between 5 and 30 Hertz.

**17.** The method of claim **13**, wherein the steps of producing an inhibitory current and the step of producing an excitation current include implanting a light source near the neuron.

**18.** The method of claim **13**, wherein the first light responsive protein has a first excitation wavelength maxima and the second light responsive protein has a second excitation wavelength maxima that is different from the first excitation wavelength maxima and wherein the first light responsive protein includes halorhodopsin and the second light responsive protein includes channelrhodopsin.

**19.** A method for controlling a voltage level across a cell membrane of a cell, the method comprising:

engineering a first light responsive protein in the cell;

measuring the voltage level across the cell membrane; and

producing, in response to light of a first wavelength and using the first light responsive protein, a first current across the cell membrane that is responsive to the measured voltage level.

**20.** The method of claim **19**, further including the steps of engineering a second light responsive protein in the cell; and

producing, in response to light of a second wavelength and using the second light responsive protein, a second current across the cell membrane that is responsive to the measured voltage level.

**21.** The method of claim **19**, wherein the production of the first current is controlled to clamp the voltage level across the cell membrane.

**22.** The method of claim **20**, wherein the step of producing the first current is in response to the measured voltage level across the cell membrane having a voltage more positive than a threshold voltage range and wherein the first current results in a negative change in the voltage level across the cell membrane.

**23.** The method of claim **22**, wherein the step of producing the second current is in response to the measured voltage level across the cell membrane having a voltage more negative than a threshold voltage range and wherein the

second current results in a positive change in the voltage level across the cell membrane.

**24.** A system for controlling an action potential of a neuron in vivo, the system comprising:

- a delivery device that introduces a light responsive protein to the neuron, wherein the light responsive protein produces an inhibitory current;
- a light source that generates light for stimulating the light responsive protein; and
- a control device that controls the generation of light by the light source.

**25.** The system of claim **24**, wherein the delivery device introduces the light responsive protein by one of transfection, transduction, electroporation and microinjection.

**26.** The system of claim **24**, wherein the light source introduces light to the neuron via one of an implantable light generator and fiber-optics.

**27.** A method for treatment of a disorder, the method comprising:

- in a group of neurons associated with the disorder, engineering inhibitory proteins that use an endogenous cofactor to respond to light by producing an inhibitory current to dissuade depolarization of the neurons; and
- exposing the neurons to light, thereby dissuading depolarization of the neurons.

**28.** The method of claim **27**, further comprising the step of imaging neurons to determine the effectiveness of the treatment.

**29.** An implantable arrangement for in vivo use, comprising:

- light-generation means for generating light; and
- a biological portion that modifies target cells to facilitate stimulation of the target cells in response to the light generated by the light-generation means.

**30.** The implantable arrangement of claim **29**, wherein the implantable arrangement is scopically-deliverable.

**31.** The implantable arrangement of claim **29**, wherein the implantable arrangement is stereotactically deliverable.

**32.** The implantable arrangement of claim **29**, wherein the biological portion modifies the target cells to produce a light-activatable ion channel protein in the target cells.

**33.** The implantable arrangement of claim **32**, wherein the light-activated ion channel protein is coded for by a virus configured to infect the target cells.

**34.** The implantable arrangement of claim **32**, wherein the light activated ion channel protein one of Channelrhodopsin-2, Chop2, ChR2-310 and Chop2-310.

**35.** The implantable arrangement of claim **29**, wherein the light-generation means includes a light-emitting-diode responsive to an input signal.

**36.** The implantable arrangement of claim **29**, wherein the biological portion includes a viral matrix containing viral vectors.

**37.** The implantable arrangement of claim **29**, wherein the biological portion includes a membrane layer containing viral vectors.

**38.** The implantable arrangement of claim **33**, wherein the light-activated ion channel protein is one of Channelrhodopsin-2, Chop2, ChR2-310 and Chop2-310.

**39.** The implantable arrangement of claim **33**, wherein the light-activated ion channel protein is halorhodopsin.

**40.** The implantable arrangement of claim **29**, wherein the target cells are neurons.

**41.** The implantable arrangement of claim **29**, wherein the stimulation includes electrical current due to depolarization of the target cell.

**42.** An implantable device for stimulating target cells modified to have a photosensitive bio-molecular structure, comprising:

- a light generator to generate light in response to an external signal; and
- a biological arrangement that modifies the target cells to include the photosensitive bio-molecular structure.

**43.** The device of claim **42**, wherein the photosensitive bio-molecular structure is a light-activatable ion channel protein.

**44.** The device of claim **42**, wherein the photosensitive bio-molecular structure is Channelrhodopsin-2.

**45.** The device of claim **42**, wherein the photosensitive bio-molecular structure is a light-activatable charged-ion membrane channel.

**46.** The device of claim **42**, wherein the photosensitive bio-molecular structure is Chop2.

**47.** The device of claim **42**, wherein the photosensitive bio-molecular structure is ChR2-310.

**48.** The device of claim **42**, wherein the photosensitive bio-molecular structure is Chop2-310.

**49.** The device of claim **42**, wherein the photosensitive bio-molecular structure is halorhodopsin.

**50.** The device of claim **42**, further including a signal-reception circuit, electrically coupled to the light generator, to respond to the external signal.

**51.** The device of claim **50**, wherein the external signal is an electromagnetic transmission, and wherein the signal-reception circuit includes at least one coil and a light-emitting diode, said at least one coil and the light-emitting diode being activated to provide the generated light in response to the electromagnetic transmission.

**52.** The device of claim **50**, wherein the external signal is a radio-frequency (RF) transmission, and wherein the signal-reception circuit includes an RF receiver being activated to provide the generated light in response to the RF transmission.

**53.** The device of claim **51**, wherein the electromagnetic transmission includes a power portion of the transmission that charges a power source and a signal portion of the transmission that is used to enable or disable the light generator.

**54.** A method for stimulating target cells using a photosensitive protein that allows the target cells to be stimulated in response to light, the method comprising:

- implanting vectors that modify the target cells to include the photosensitive protein;
- implanting a light generating device near the target cells; and
- activating the light generating device to generate light to be received by the target cells, thereby stimulating the target cells in response to the generated light.

**55.** The method of claim **54**, wherein the steps of implanting is accomplished using stereotactic surgery.

**56.** The method of claim **54**, wherein the step of implanting vectors includes using a viral matrix to contain the vectors until implanted, wherein the vectors are released from the viral matrix in vivo thereby infecting the target cells to induce production of photosensitive proteins in vivo.

- 57.** The method of claim **54**, further including the step of using a growth medium to grow the target cells, wherein the target cells contain the photosensitive protein.
- 58.** The method of claim **54**, wherein the target cells are neurons and the photosensitive protein is part of a viral vector.
- 59.** The method of claim **54**, wherein the step of activating the light generating device is in response to an external signal.
- 60.** The method of claim **59**, wherein the external signal is an electromagnetic signal.
- 61.** The method of claim **59**, wherein the external signal is a radio-frequency signal.
- 62.** The method of claim **59**, wherein the external signal includes a power portion of the external signal that charges a power source and a signal portion of the external signal that is used to enable or disable the light generator.
- 63.** An arrangement for stimulating target cells using a photosensitive protein that allows the target cells to be stimulated in response to light, the arrangement including:  
 means for implanting vectors that modify the target cells to include the photosensitive protein;  
 means for implanting a light generating device near the target cells; and  
 means for activating the light generating device to generate light to be received by the target cells, thereby stimulating the target cells in response to the generated light.
- 64.** The arrangement of claim **63**, wherein the stimulation results in activation of the target cells.
- 65.** The arrangement of claim **63**, wherein the stimulation results in suppression of activity by the target cells.
- 66.** A system for screening chemicals to identify their effects on cell membrane ion channels and pumps, comprising:

- screening cells having light responsive cation channels, anion pumps, voltage gated cation channels and fluorescence producing voltage sensors;  
 a chemical delivery device for introducing a chemical to be screened;  
 an optical delivery device to activate the light responsive cation channels;  
 an optical sensor to monitor fluorescence produced by the voltage sensors;  
 a processor to process data received from the optical sensor; and  
 memory for storing the data received from the optical sensor.
- 67.** A method for screening chemicals to identify their effects on cell membrane ion channels and pumps, comprising:  
 introducing a chemical to be screened to cells having light responsive cation channels, anion pumps, voltage gated cation channels and fluorescence producing voltage sensors;  
 activating the light responsive cation channels by generating light pulses;  
 detecting fluorescence produced by the voltage sensors;  
 processing data from the detection to identify changes in electrical properties of the cells; and  
 storing the processed data.
- 68.** A method for controlling maturation of a stem or progenitor cell having a cell membrane, the method comprising:  
 engineering a light responsive protein in the cell;  
 optically stimulating the light responsive protein to produce a current across the cell membrane to affect maturation of the cell.

\* \* \* \* \*