



(19) **United States**

(12) **Patent Application Publication**
Martini et al.

(10) **Pub. No.: US 2017/0316889 A1**

(43) **Pub. Date: Nov. 2, 2017**

(54) **ADVANCED ELECTROLYTE SYSTEMS AND THEIR USE IN ENERGY STORAGE DEVICES**

(71) Applicants: **Fabrizio Martini**, Boston, MA (US); **Riccardo Signorelli**, Boston, MA (US); **John J. Cooley**, Boston, MA (US); **Christopher John Sibbald Deane**, Boston, MA (US); **James Epstein**, Sharon, MA (US); **Padmanaban Sasthan Kuttipillai**, Malden, MA (US); **Lindsay A. Wilhelmus**, Cambridge, MA (US)

(72) Inventors: **Fabrizio Martini**, Boston, MA (US); **Riccardo Signorelli**, Boston, MA (US); **John J. Cooley**, Boston, MA (US); **Christopher John Sibbald Deane**, Boston, MA (US); **James Epstein**, Sharon, MA (US); **Padmanaban Sasthan Kuttipillai**, Malden, MA (US); **Lindsay A. Wilhelmus**, Cambridge, MA (US)

(73) Assignee: **FastCAP SYSTEMS Corporation**, Boston, MA (US)

(21) Appl. No.: **15/376,618**

(22) Filed: **Dec. 12, 2016**

Related U.S. Application Data

(63) Continuation of application No. 13/776,603, filed on Feb. 25, 2013, now Pat. No. 9,558,894, which is a continuation-in-part of application No. 13/553,716, filed on Jul. 19, 2012, now abandoned, said application No. 13/776,603 is a continuation-in-part of application No. PCT/US2012/045994, filed on Jul. 9, 2012.

(60) Provisional application No. 61/724,775, filed on Nov. 9, 2012, provisional application No. 61/619,203, filed on Apr. 2, 2012, provisional application No. 61/602,713, filed on Feb. 24, 2012, provisional application No. 61/569,010, filed on Dec. 9, 2011, provisional application No. 61/560,888, filed on Nov. 17, 2011, provisional application No. 61/512,090, filed on Jul. 27, 2011, provisional application No. 61/619,203,

filed on Apr. 2, 2012, provisional application No. 61/602,713, filed on Feb. 24, 2012, provisional application No. 61/569,010, filed on Dec. 9, 2011, provisional application No. 61/560,888, filed on Nov. 17, 2011, provisional application No. 61/512,090, filed on Jul. 27, 2011, provisional application No. 61/505,715, filed on Jul. 8, 2011, provisional application No. 61/602,713, filed on Feb. 24, 2012.

Publication Classification

- (51) **Int. Cl.**
 - H01G 11/30* (2013.01)
 - H01G 11/36* (2013.01)
 - H01G 11/52* (2013.01)
 - H01M 10/0568* (2010.01)
 - H02J 7/00* (2006.01)
 - H01G 11/34* (2013.01)
 - H01M 10/052* (2010.01)
 - H01M 2/16* (2006.01)
 - H01M 2/06* (2006.01)
 - H01M 2/16* (2006.01)
 - H01M 2/16* (2006.01)
 - H01M 10/0563* (2010.01)
- (52) **U.S. Cl.**
 - CPC *H01G 11/30* (2013.01); *H01G 11/34* (2013.01); *H01G 11/36* (2013.01); *H01G 11/52* (2013.01); *H01M 10/0568* (2013.01); *H01M 10/052* (2013.01); *H02J 7/00* (2013.01); *H01M 2/065* (2013.01); *H01M 2/1613* (2013.01); *Y02P 70/54* (2015.11); *H01M 2/1653* (2013.01); *H01M 10/0563* (2013.01); *Y02E 60/122* (2013.01); *H01M 2/1646* (2013.01)

(57) **ABSTRACT**

An ultracapacitor that includes an energy storage cell immersed in an advanced electrolyte system and disposed within a hermetically sealed housing, the cell electrically coupled to a positive contact and a negative contact, wherein the ultracapacitor is configured to output electrical energy within a temperature range between about -40 degrees Celsius to about 210 degrees Celsius. Methods of fabrication and use are provided.

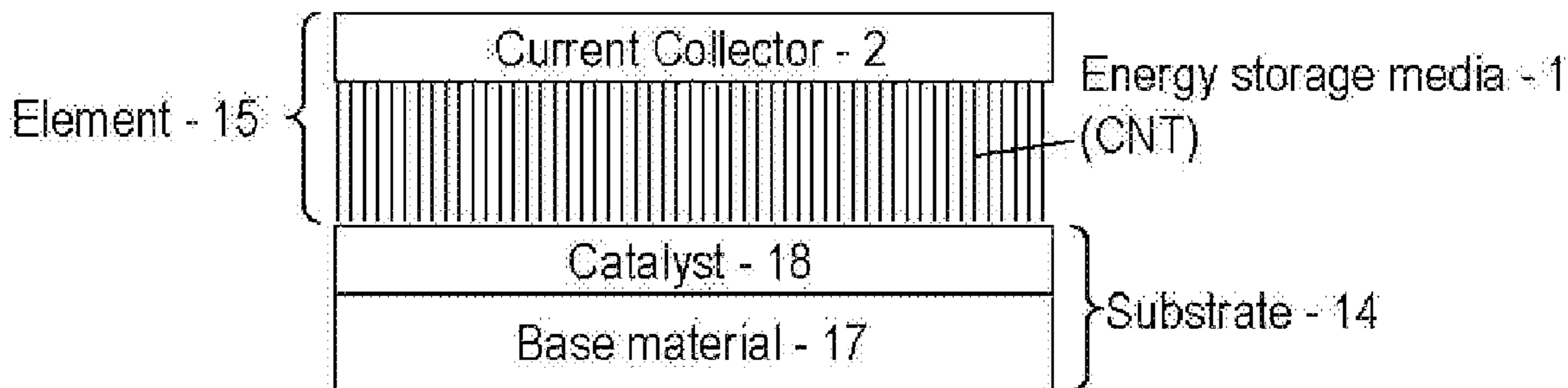

Fig. 1

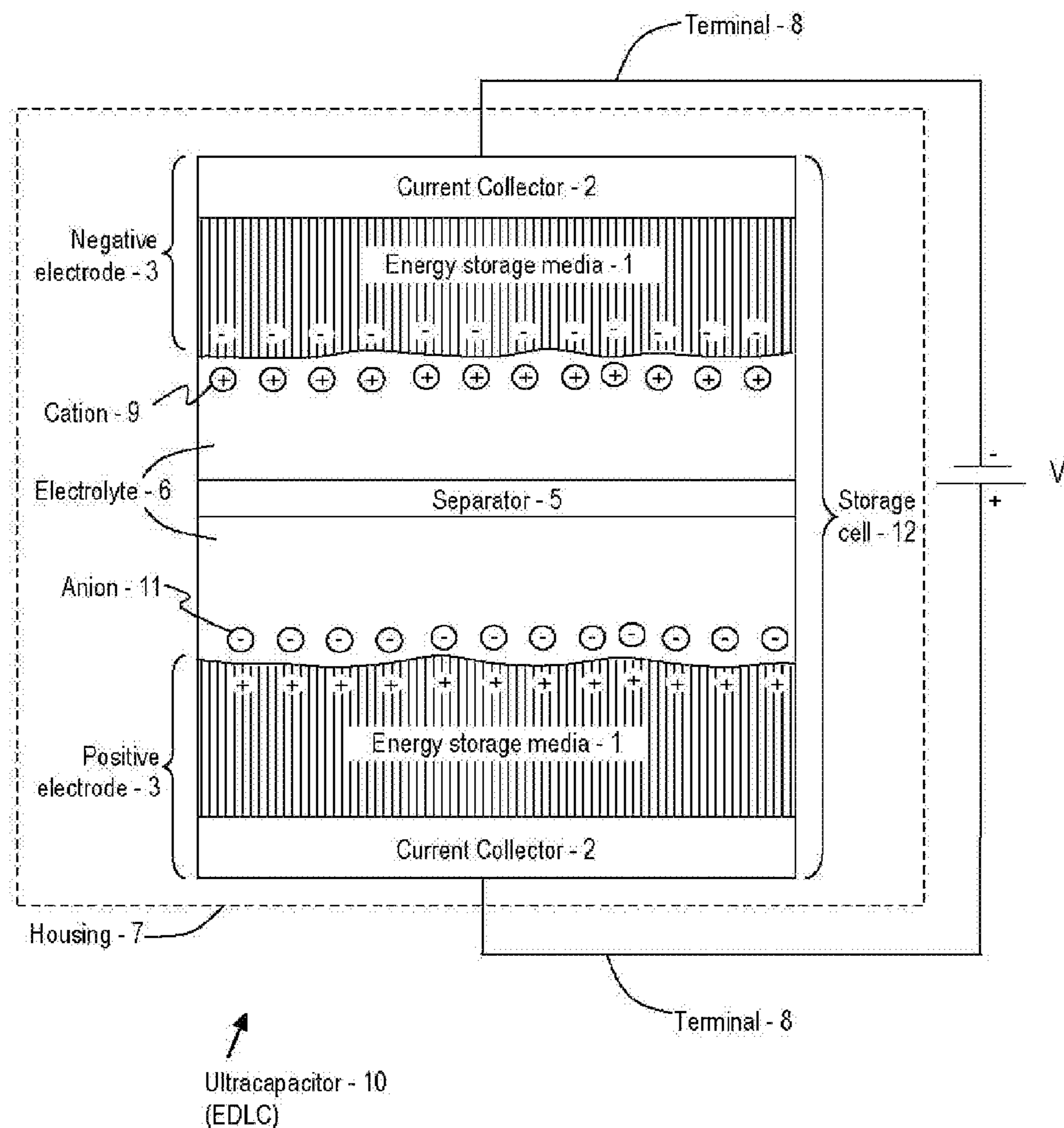

Fig. 2

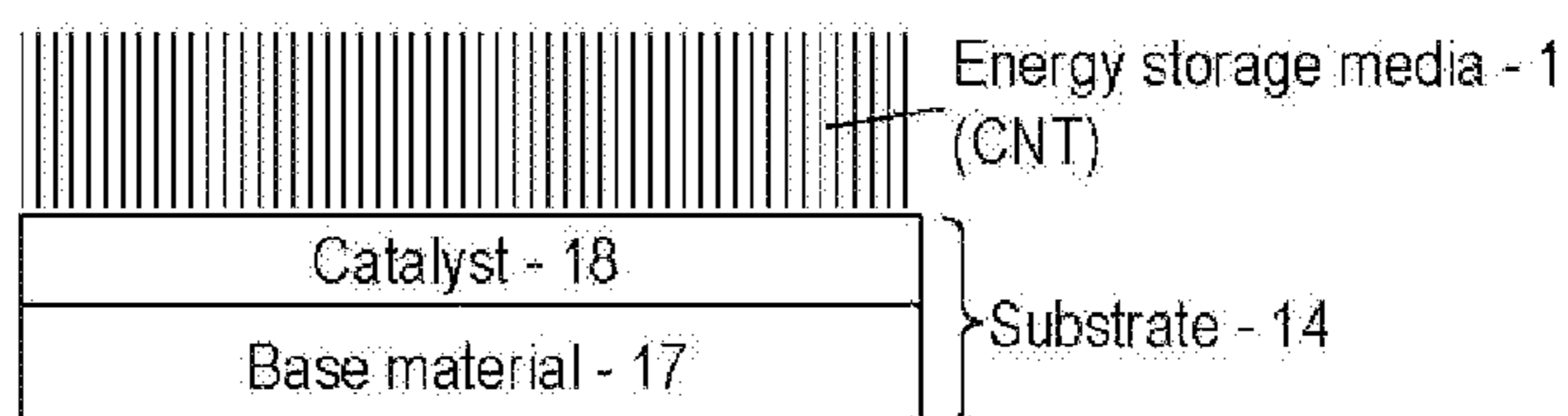

Fig. 3

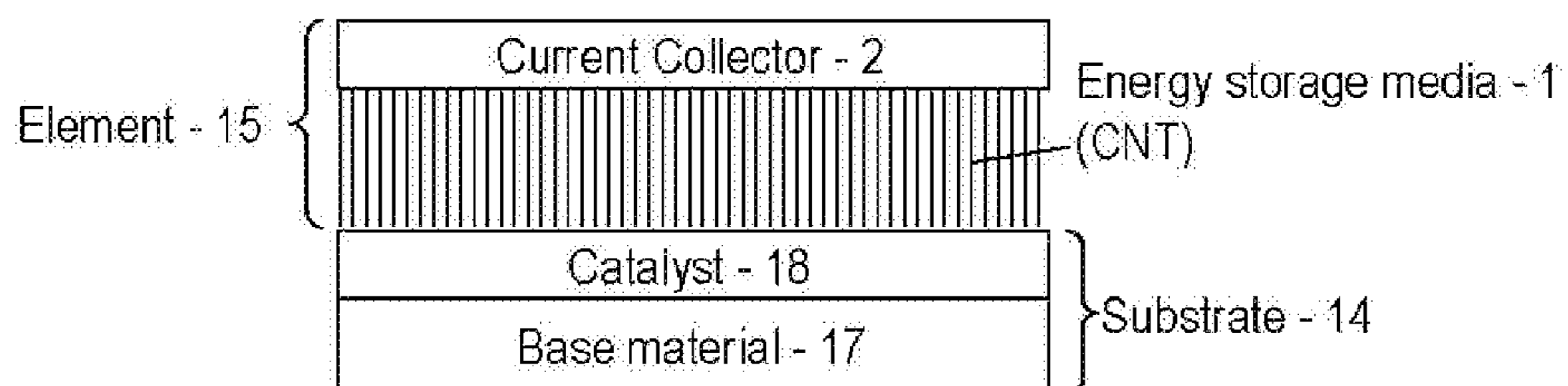

Fig. 4

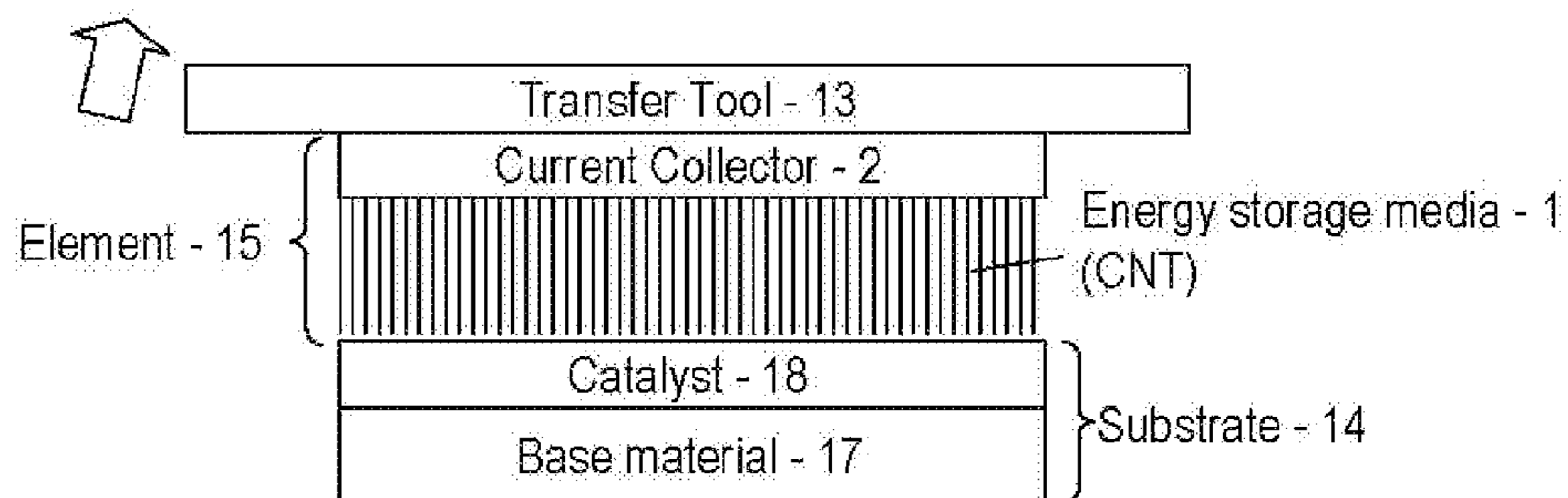

Fig. 5

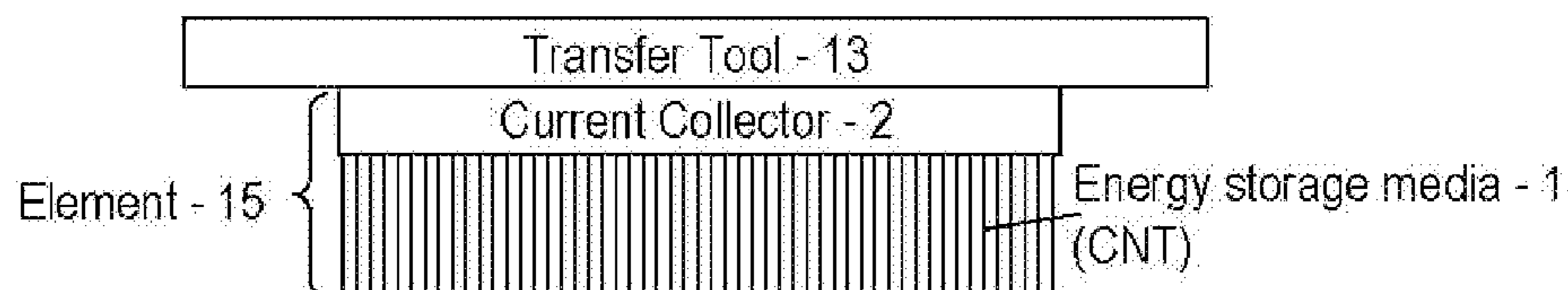

Fig. 6

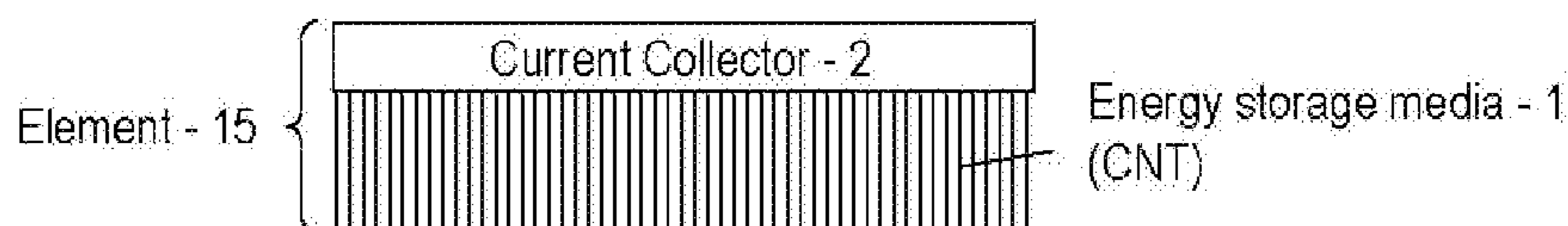

Fig. 7

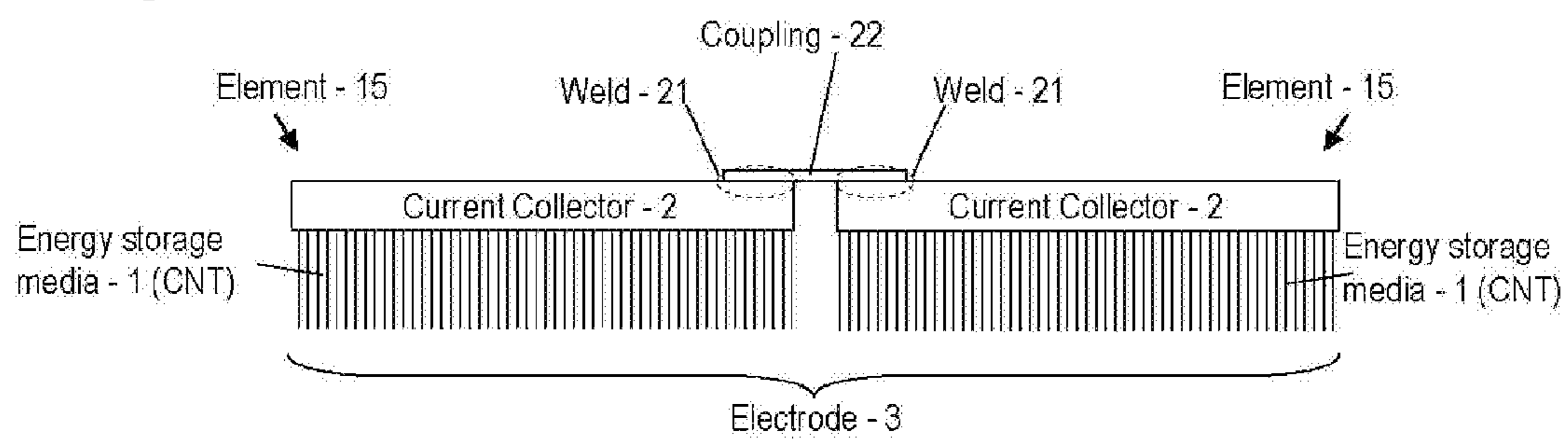
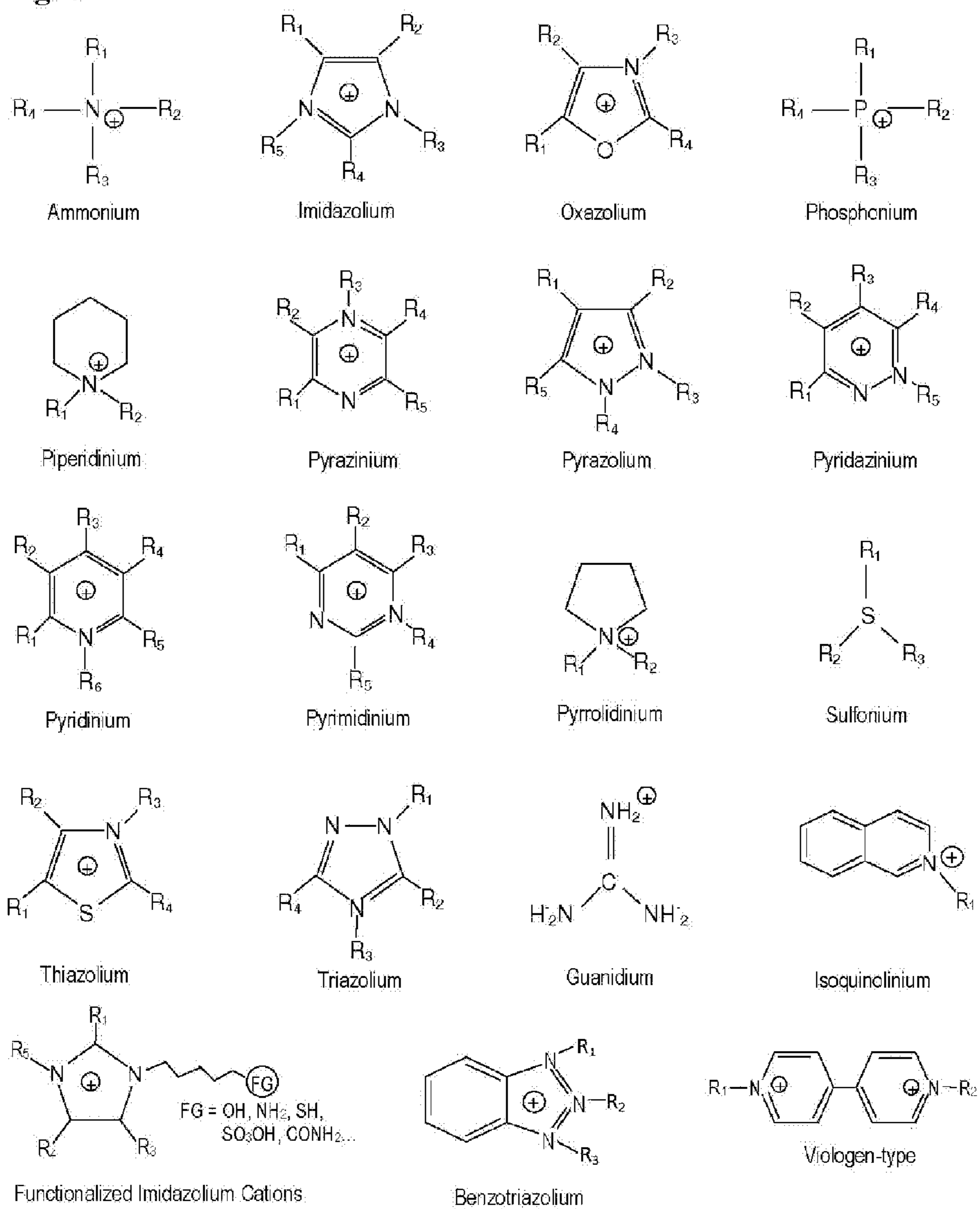

Fig. 8



Primary Structures of Cations

Fig. 9

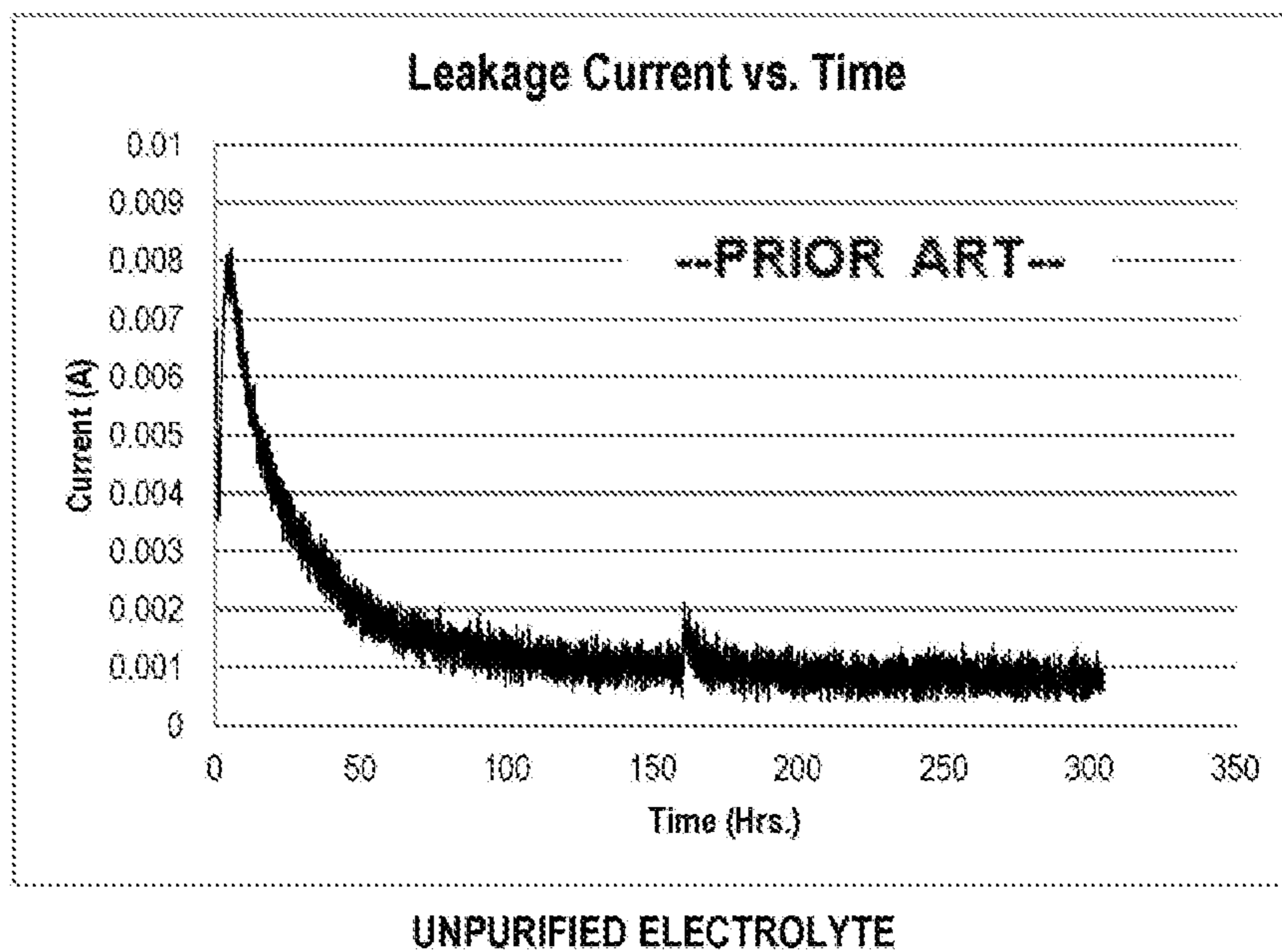

Fig. 10

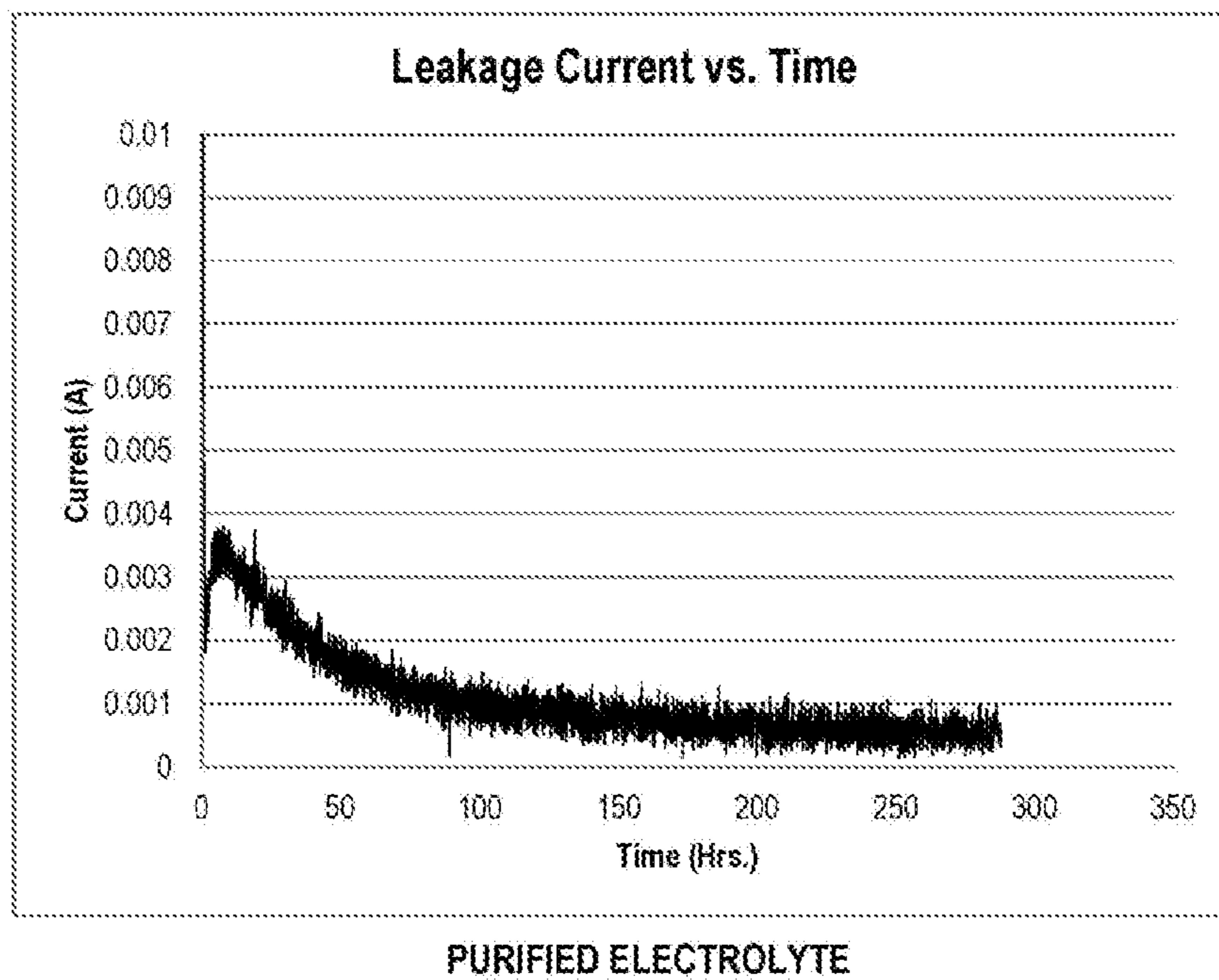

Fig. 11

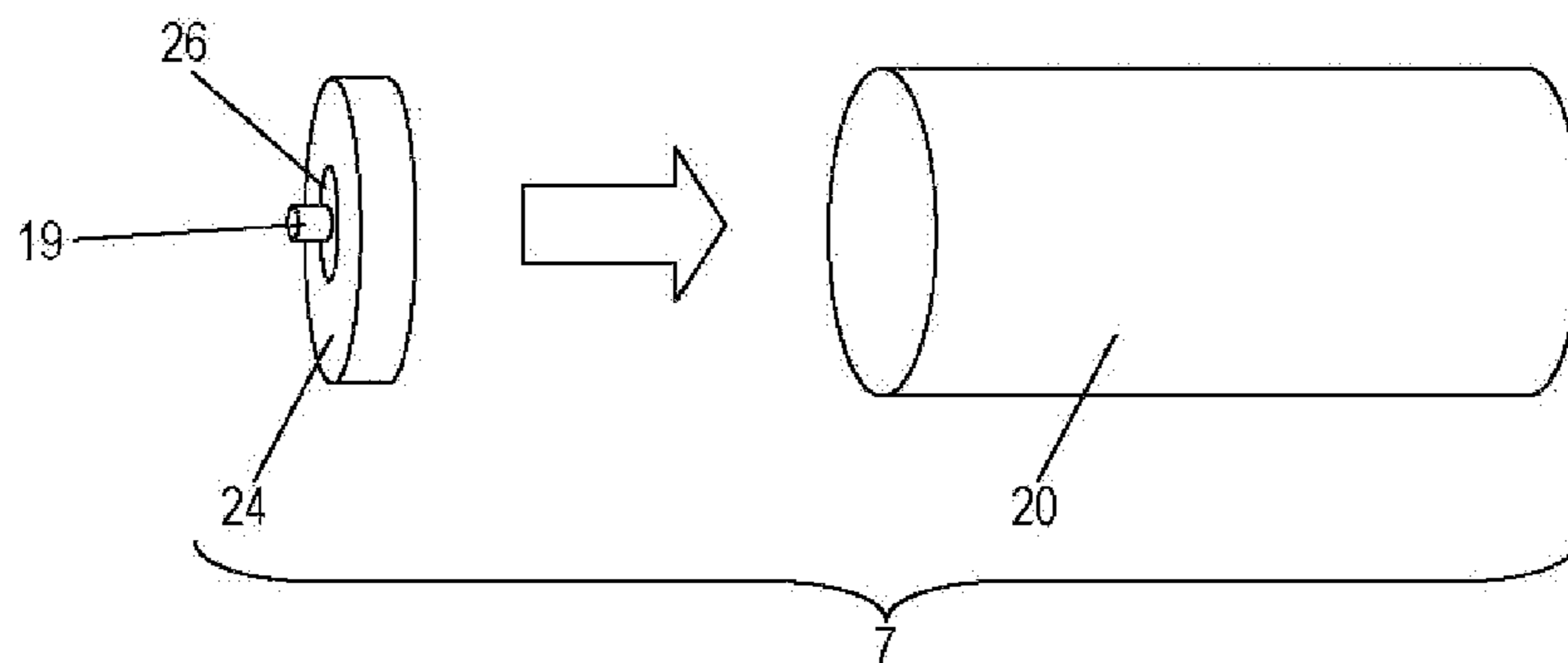

Fig. 12

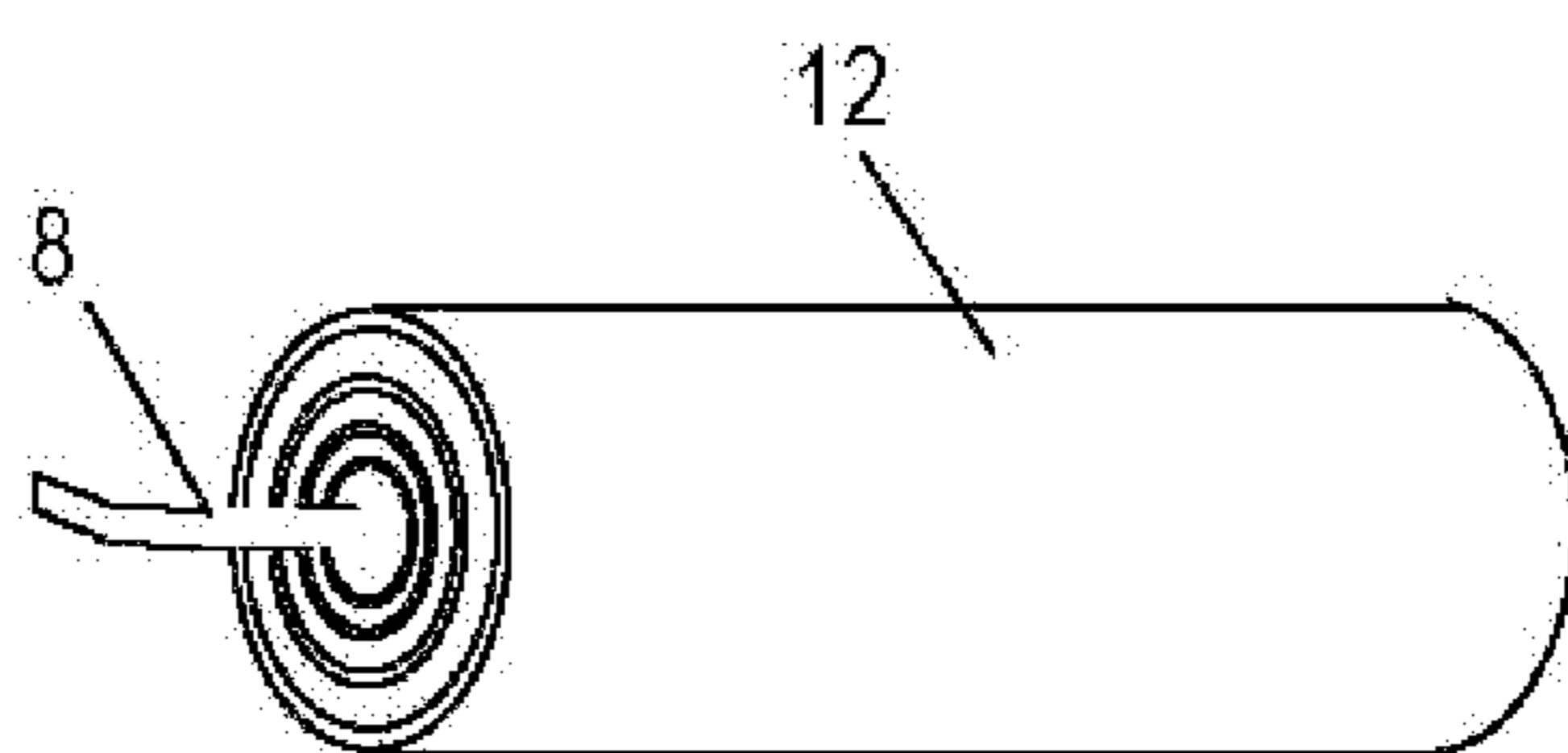

Fig. 13

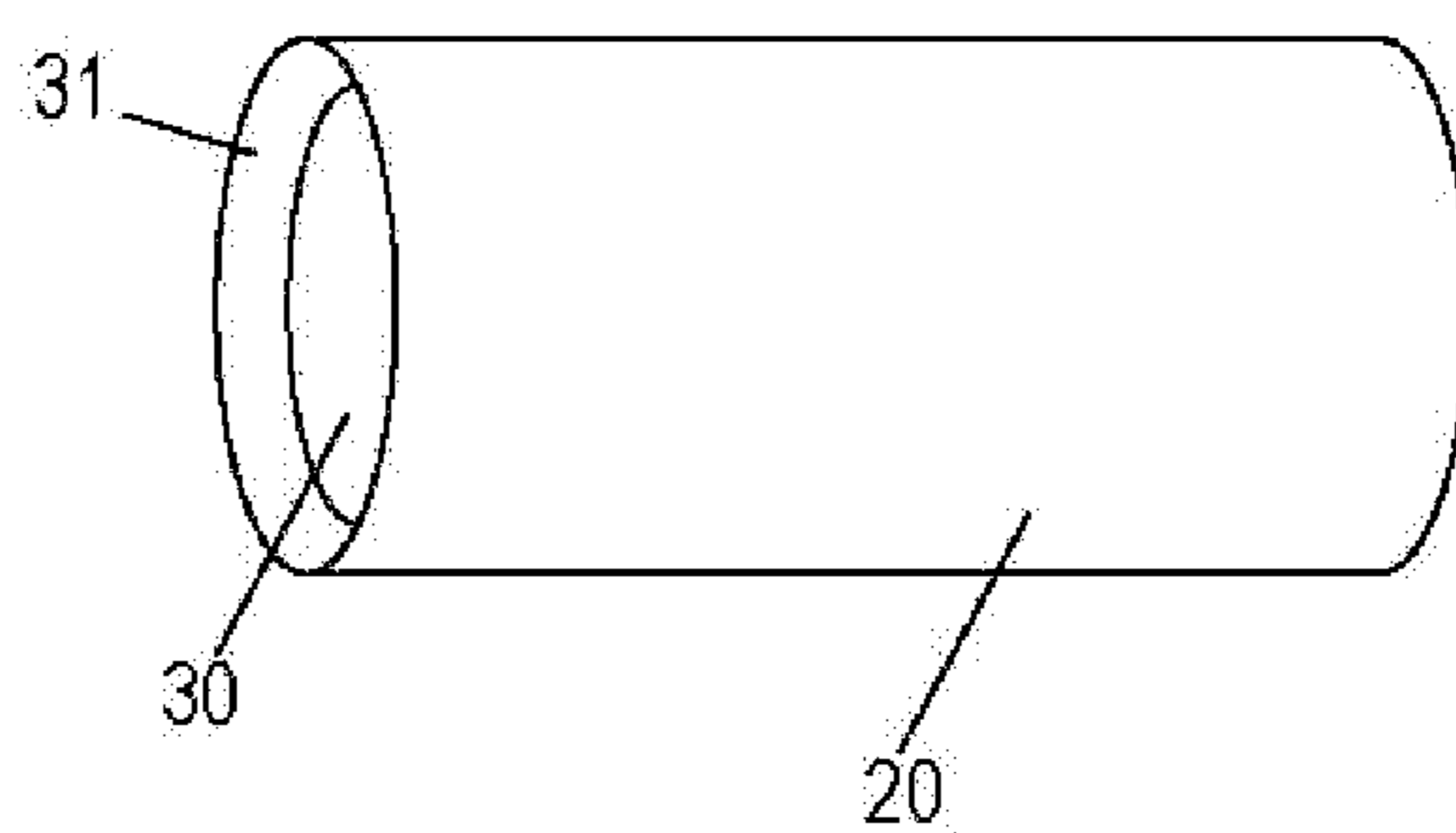

Fig. 14A

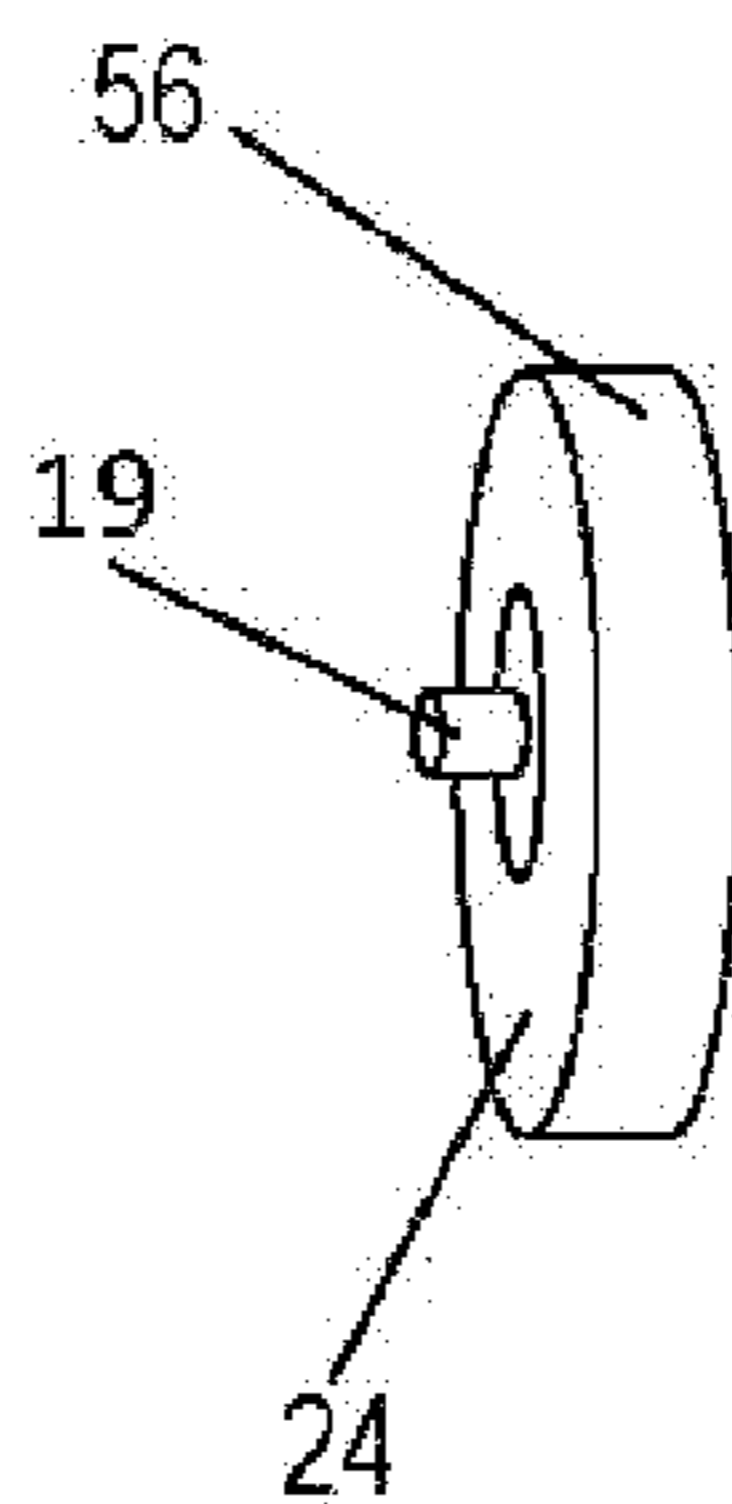

Fig. 14B

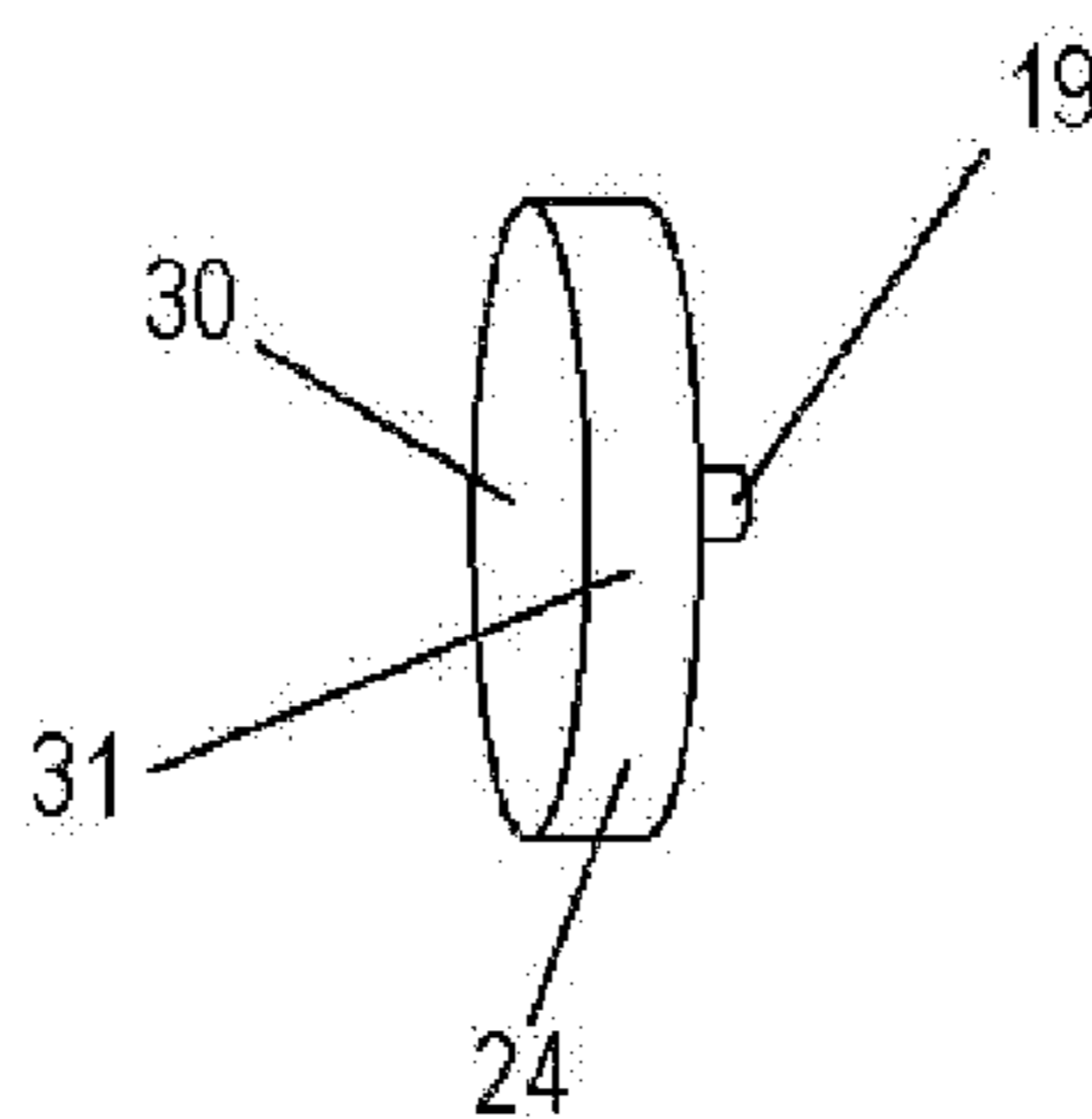

Fig. 15

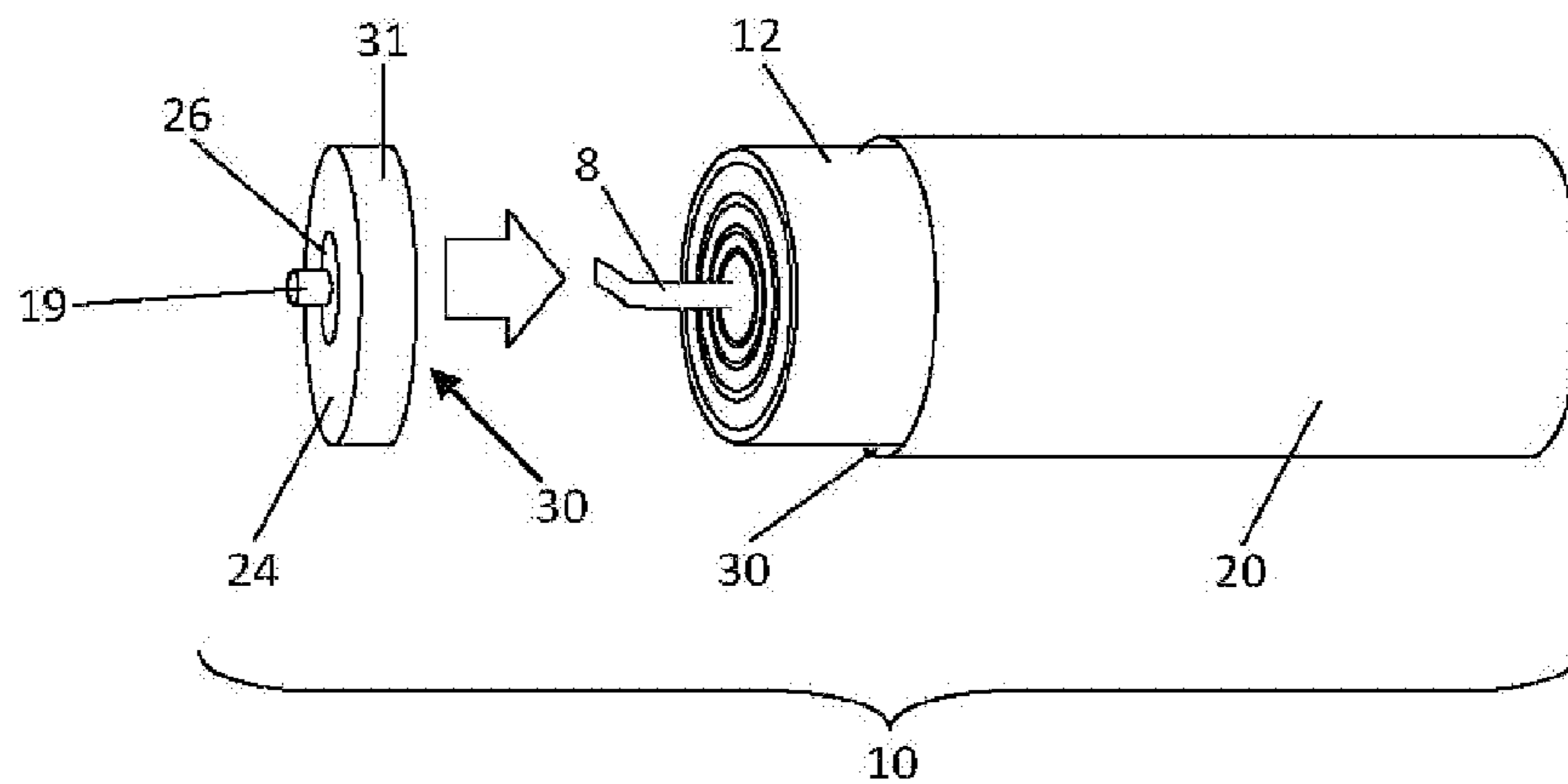
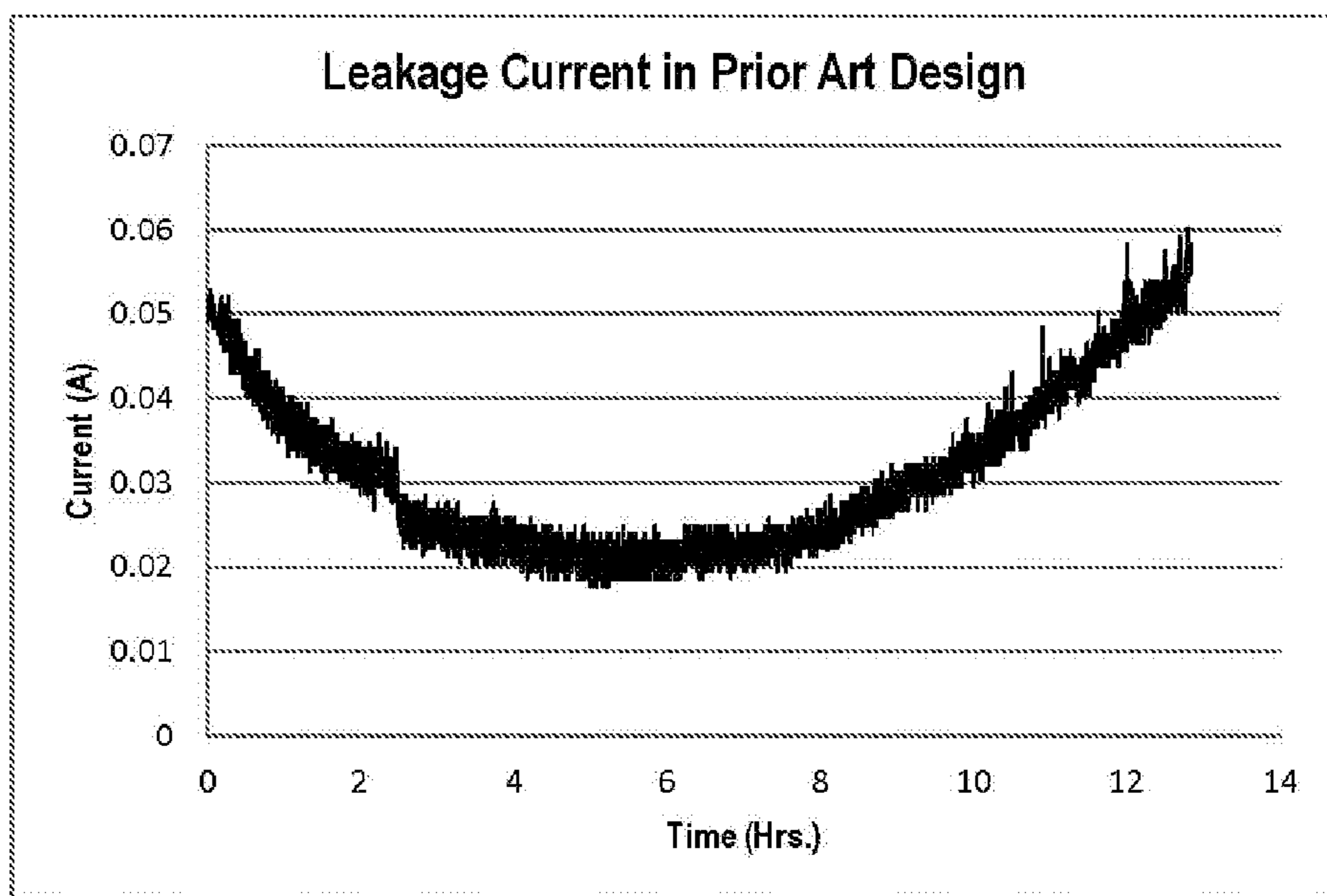
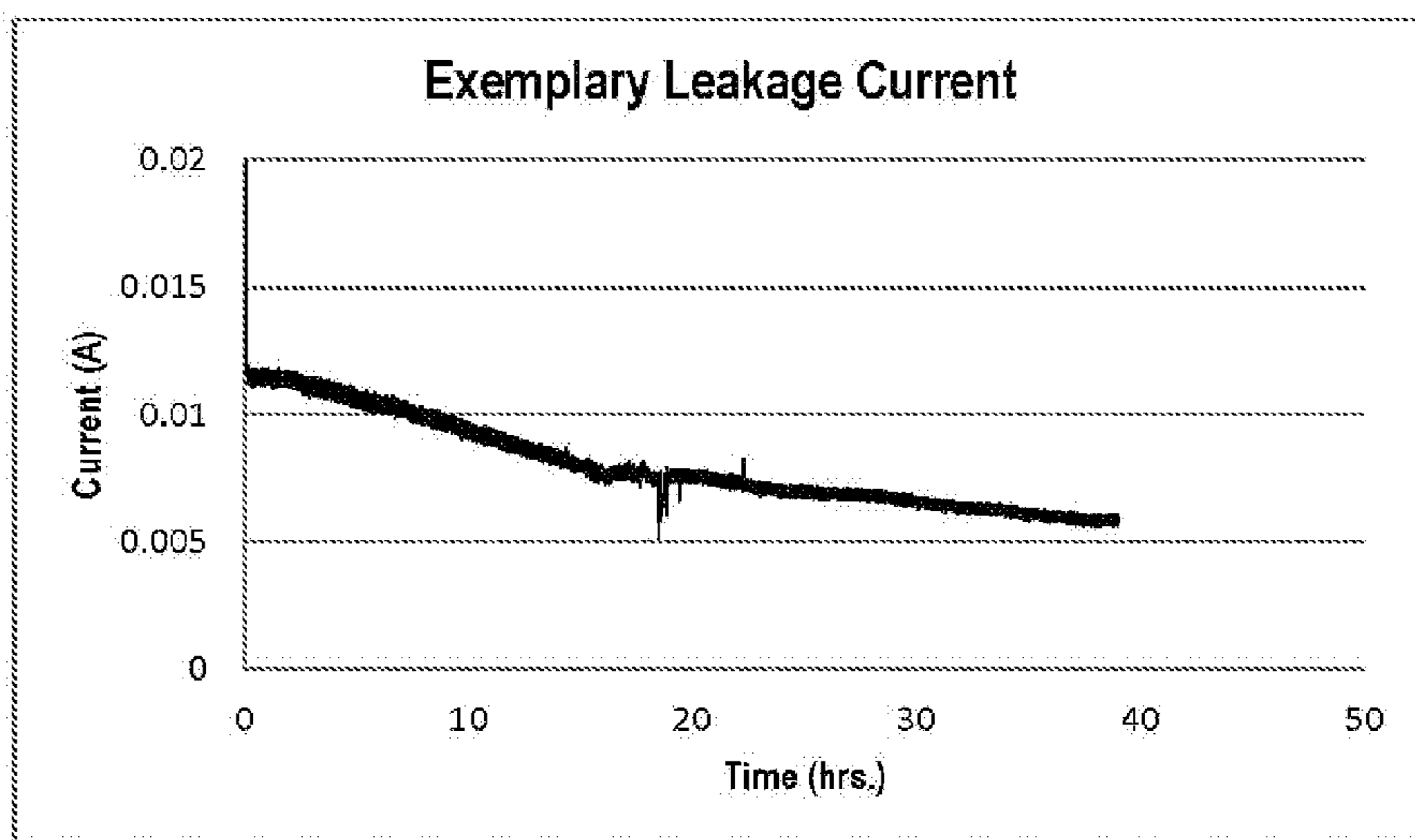

Fig. 16A



HOUSING WITH EXPOSED INTERNAL SURFACES

Fig. 16B



HOUSING WITH BARRIER OVER INTERNAL SURFACES

Fig. 17

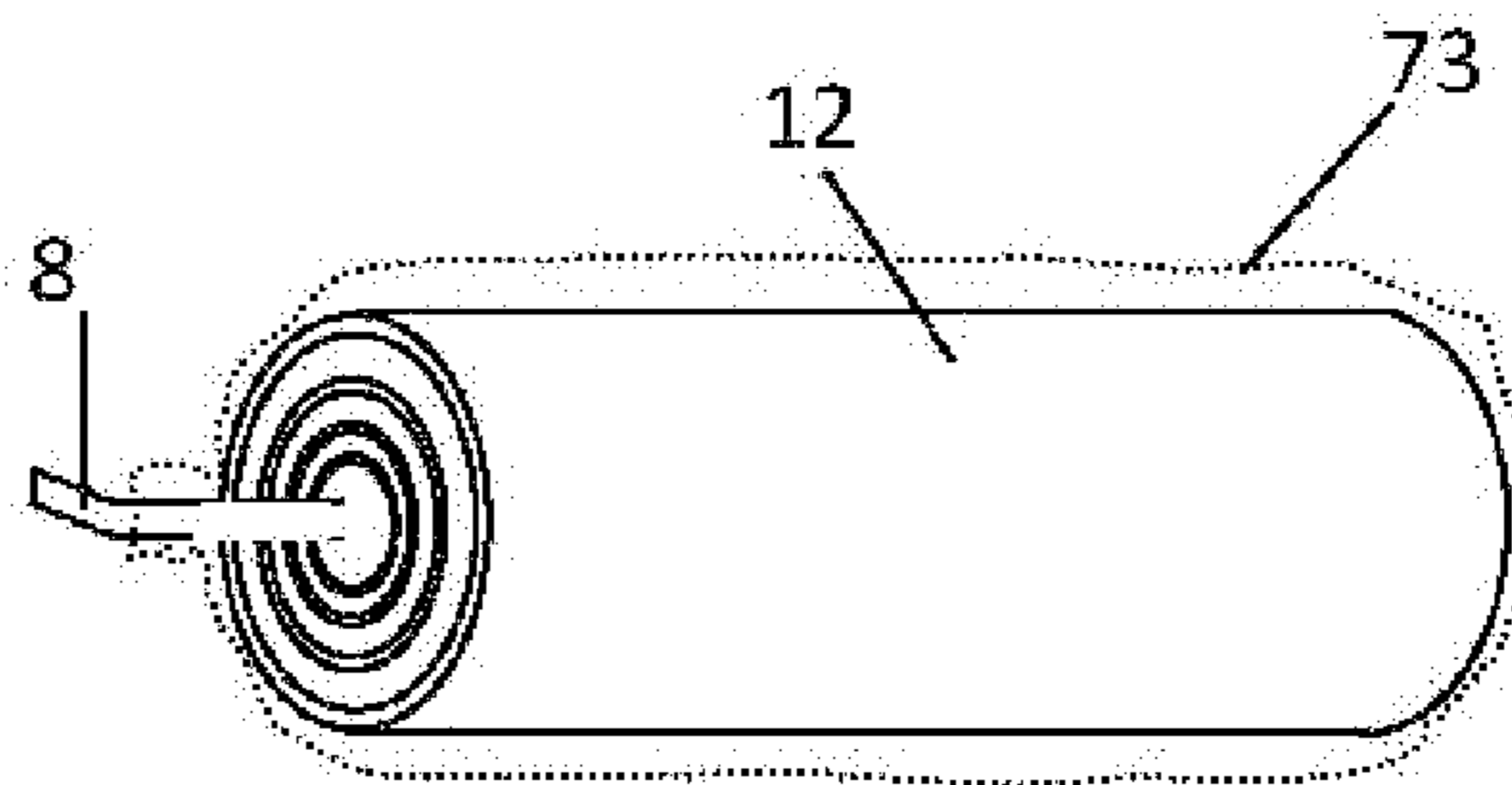

Fig. 18A

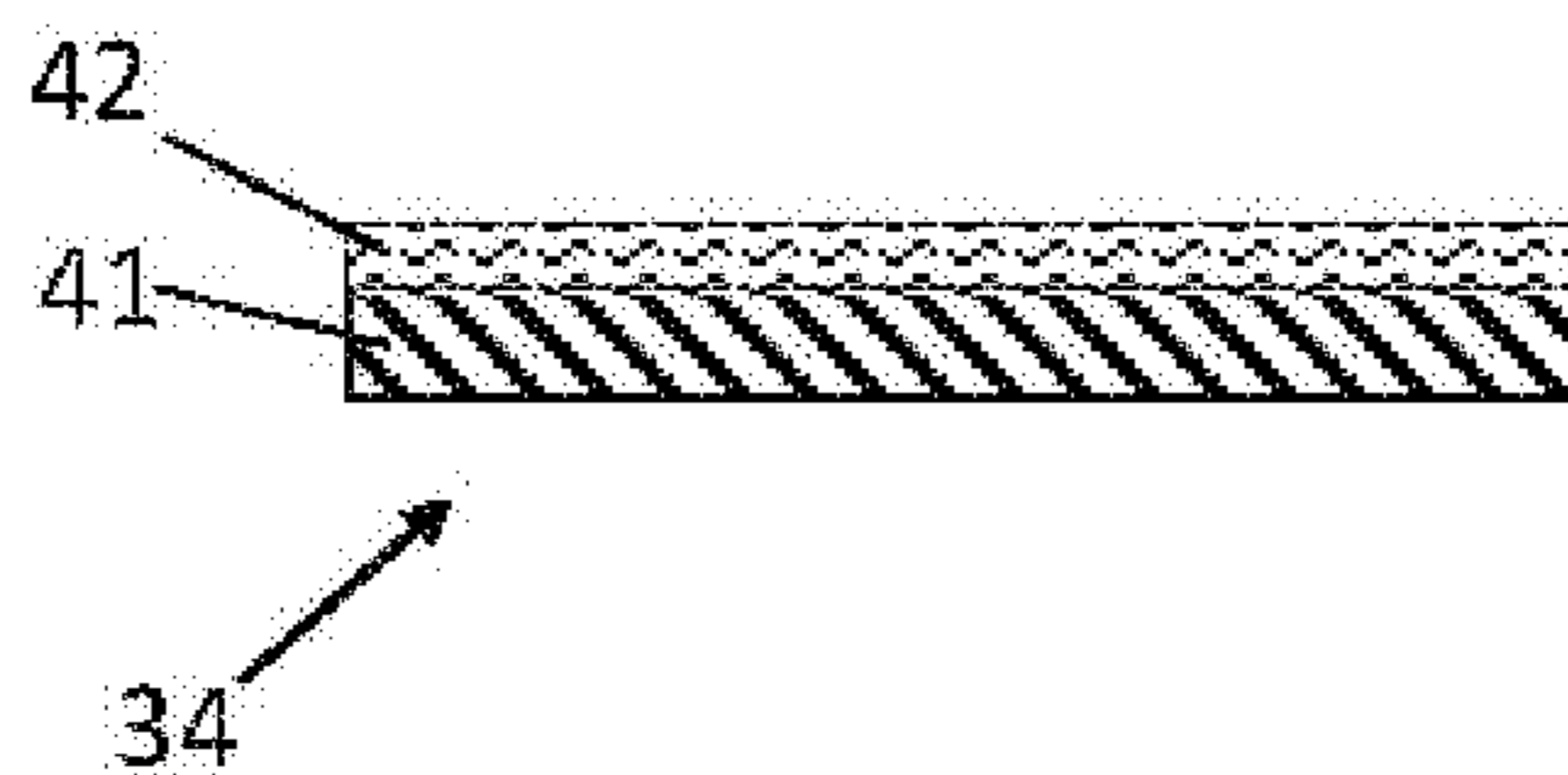

Fig. 18B

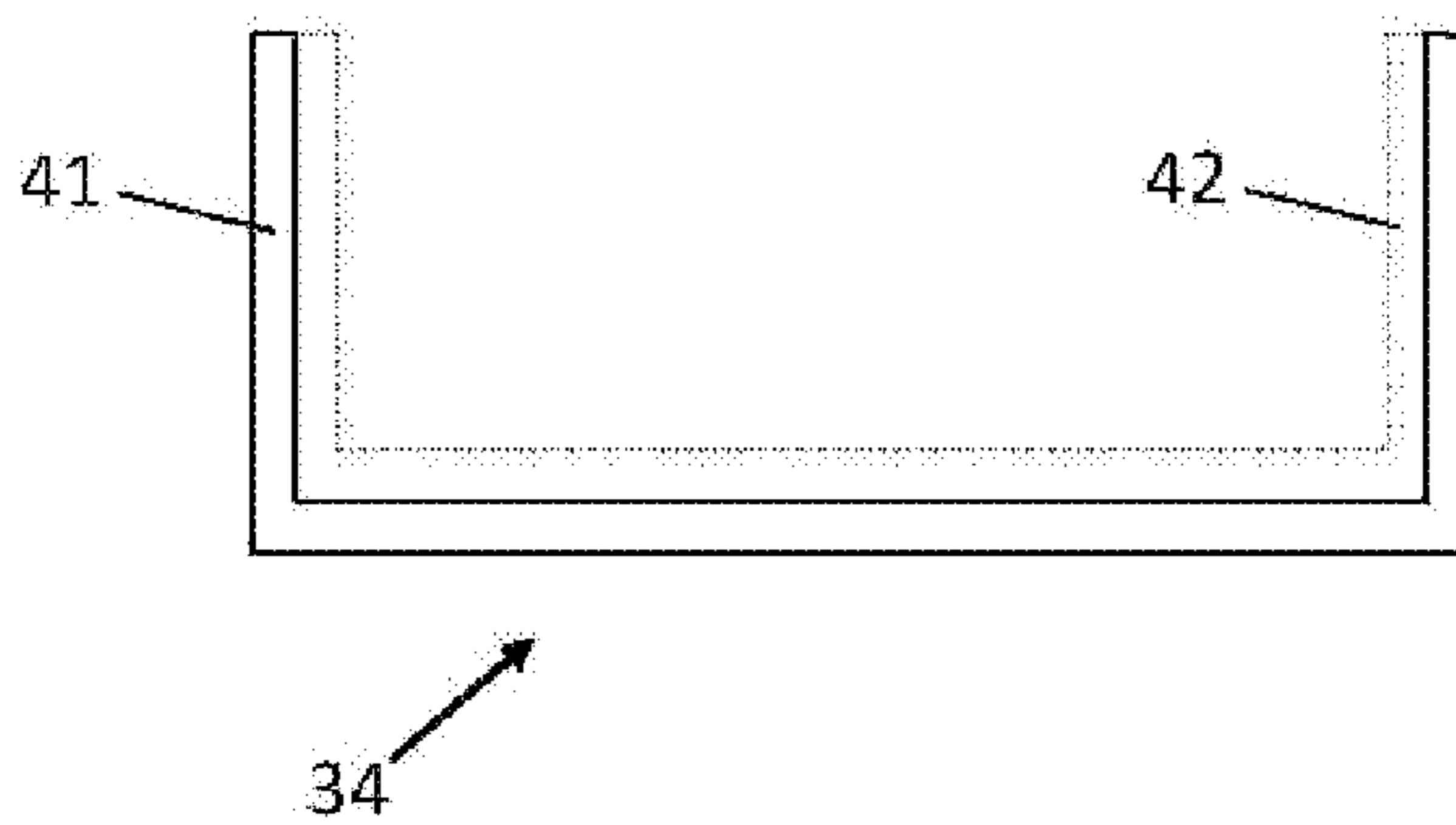

Fig. 18C

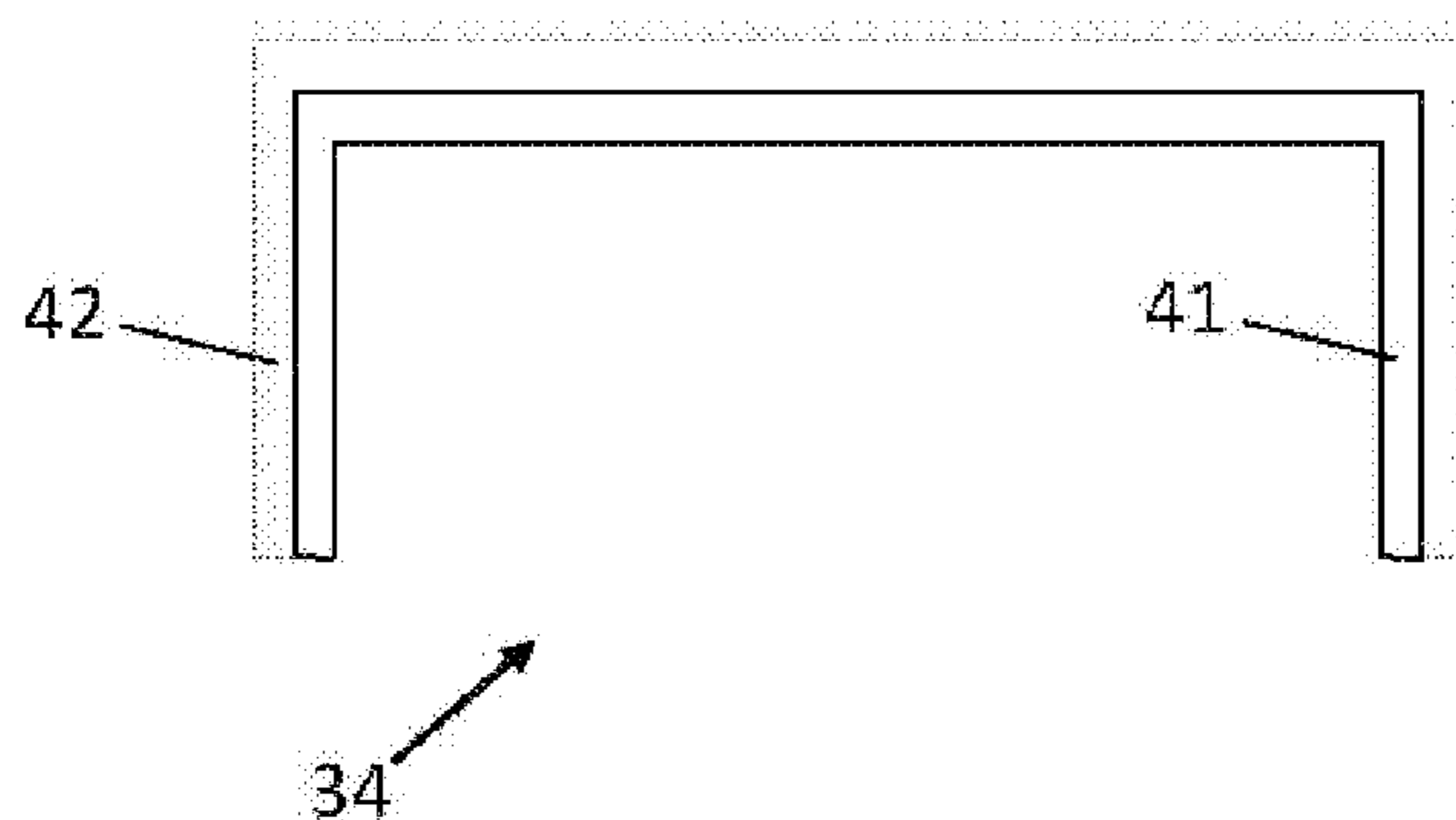

Fig. 19

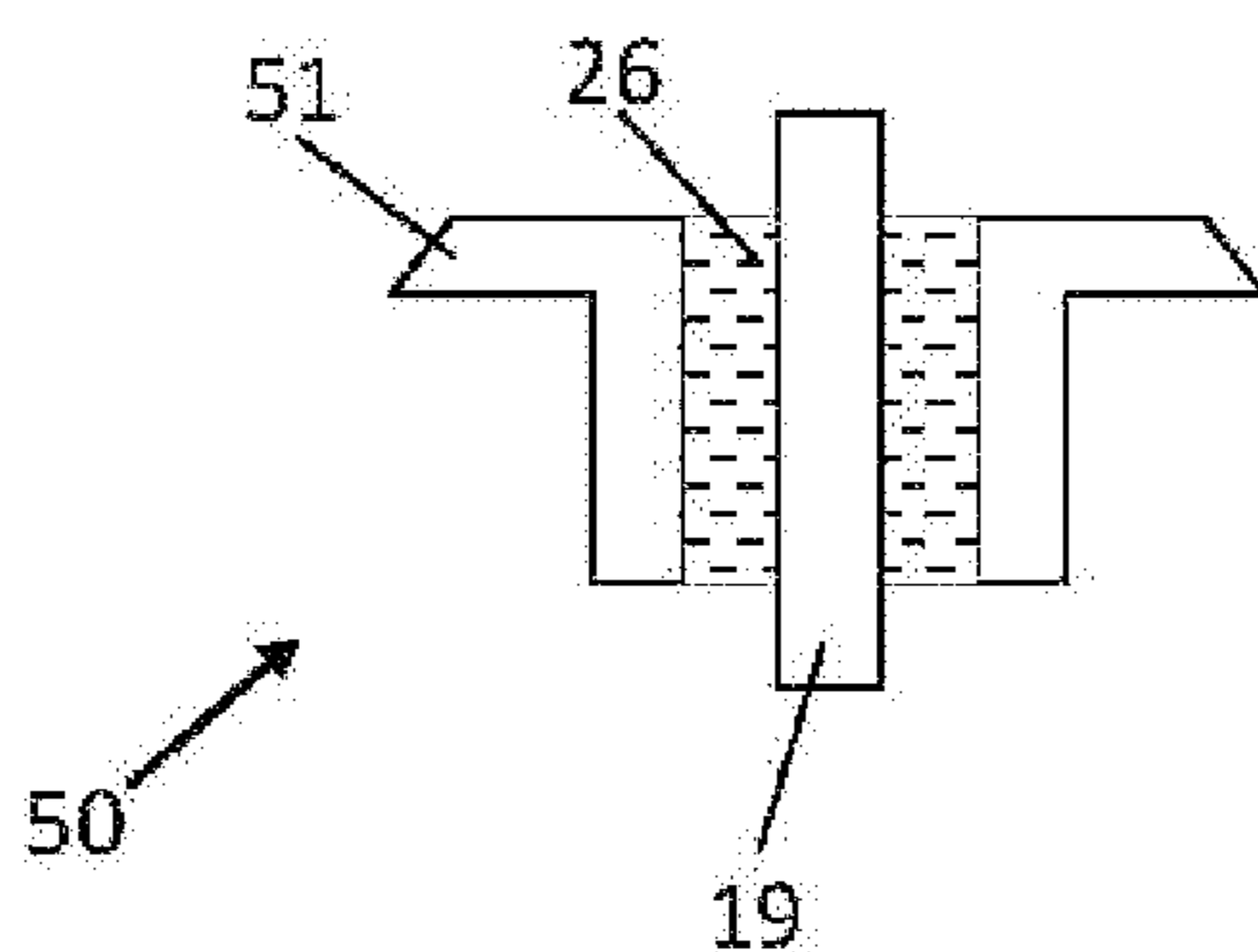

Fig. 20

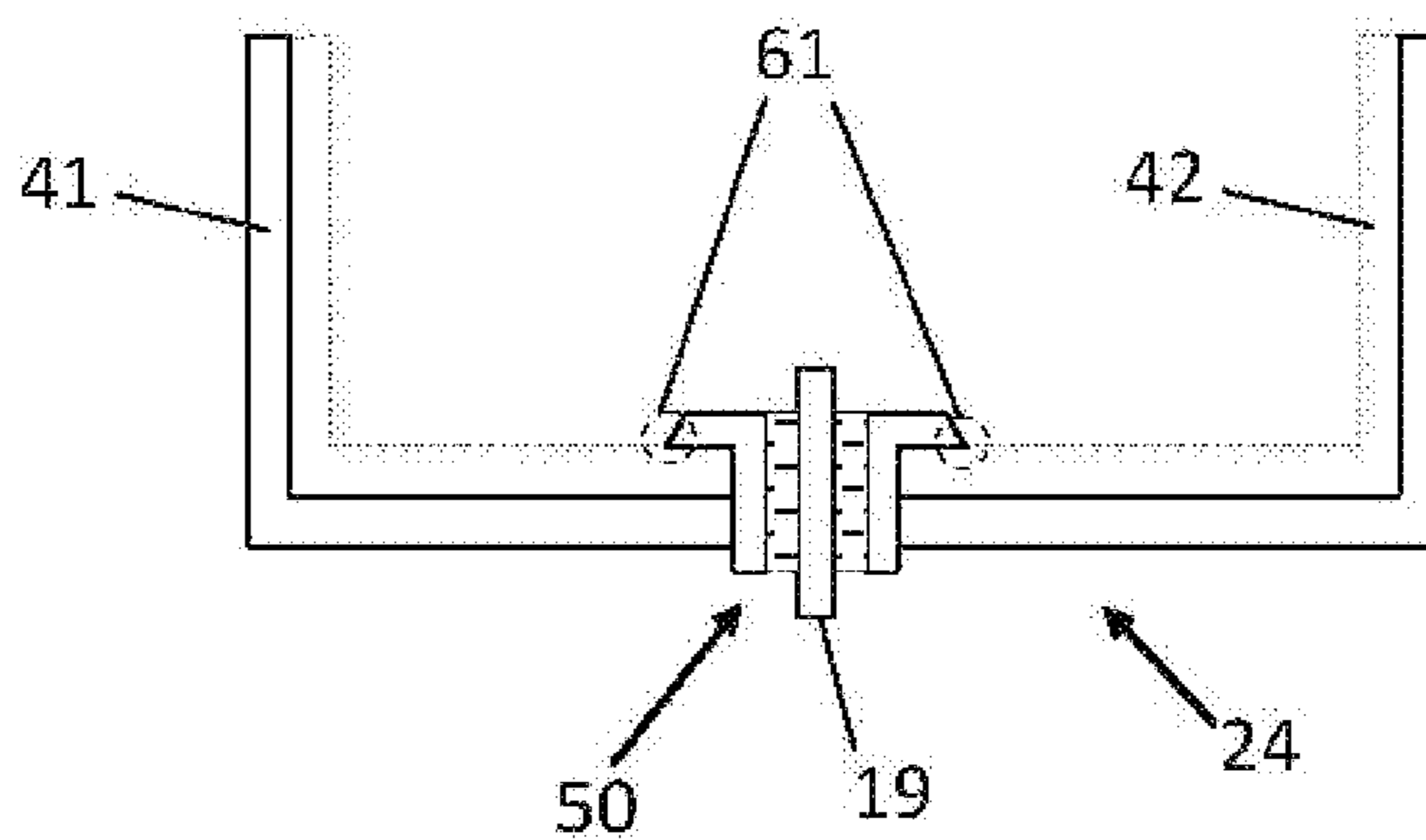

Fig. 21

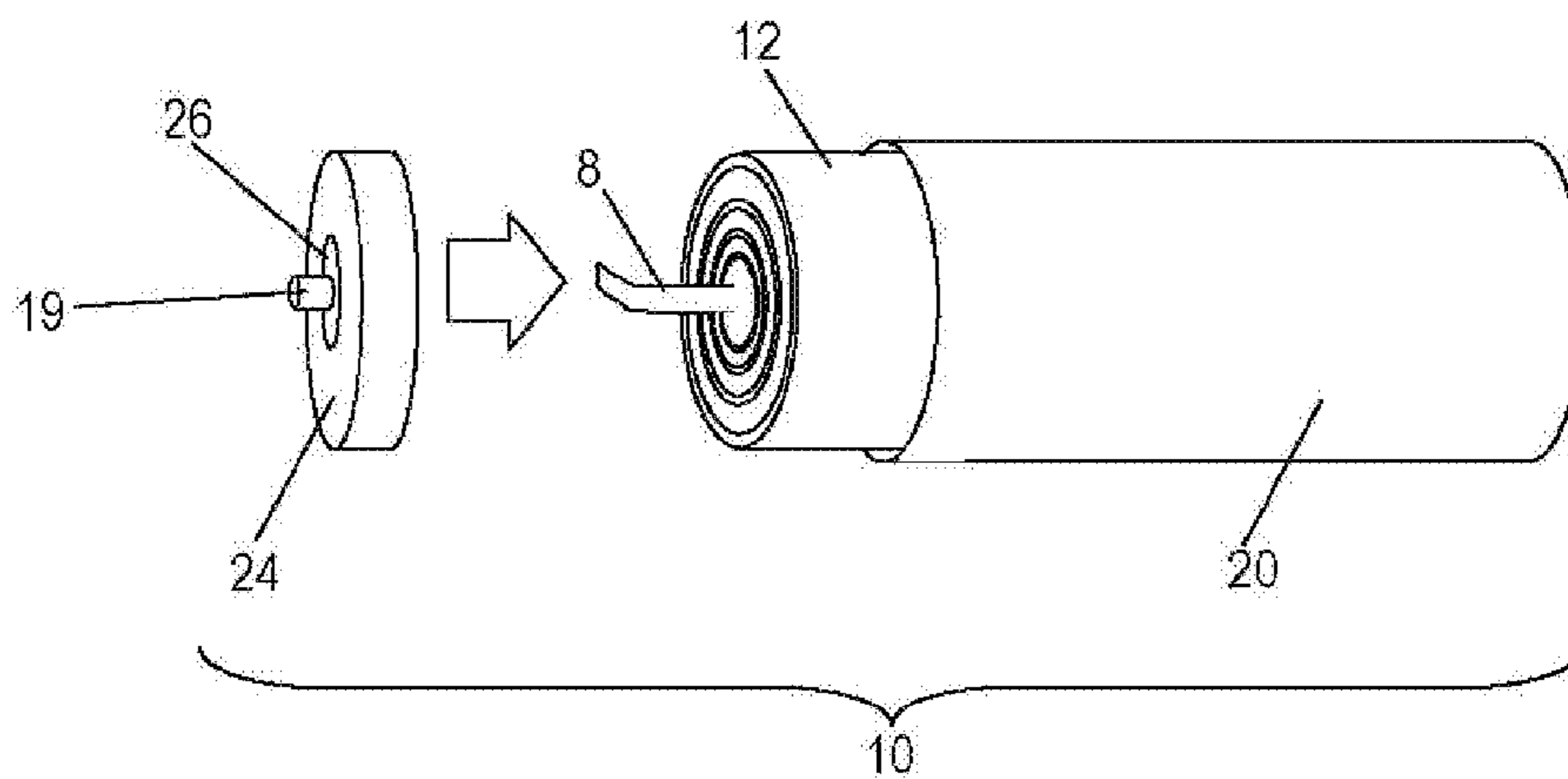

Fig. 22A

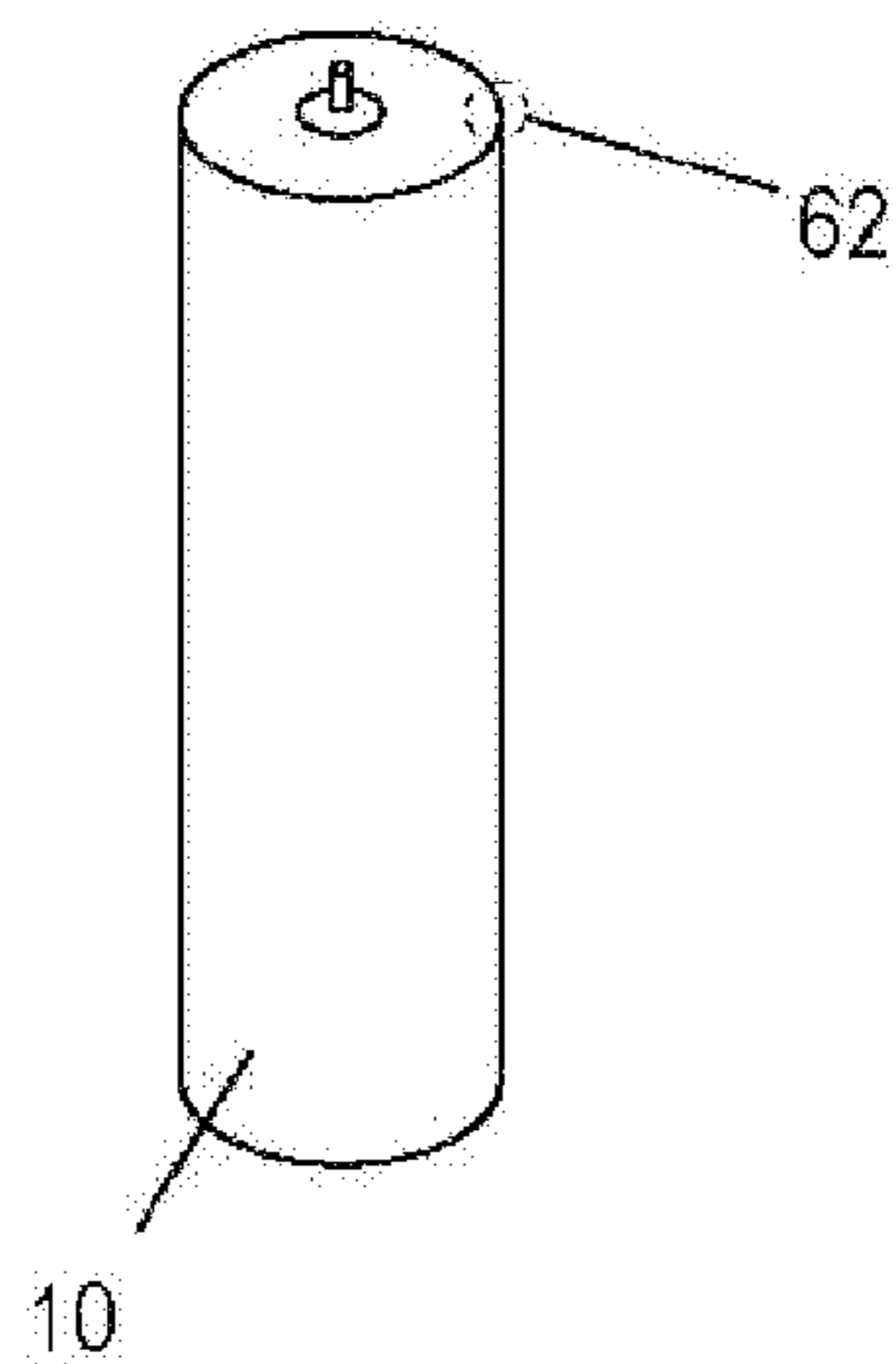

Fig. 22B

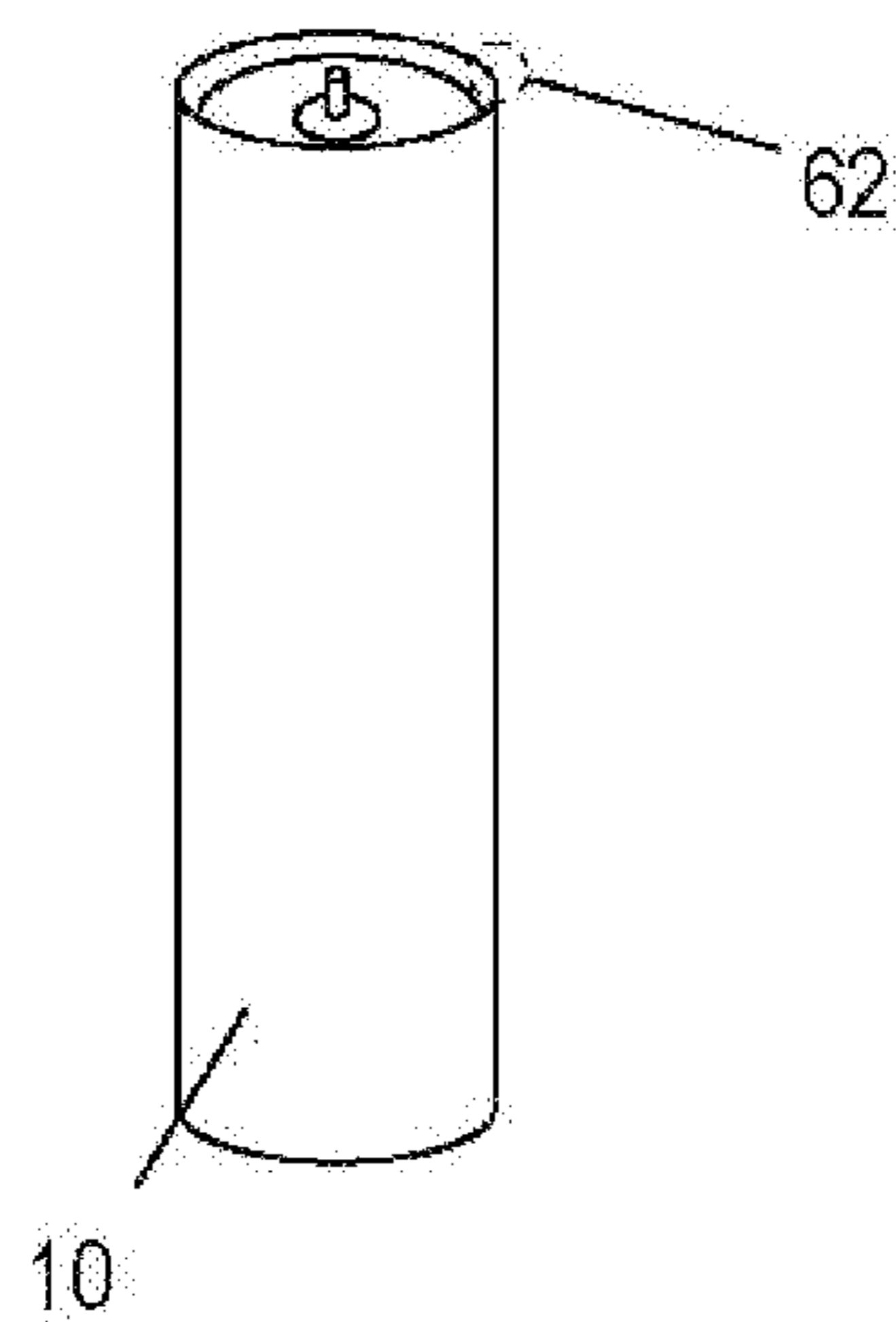

Fig. 22C

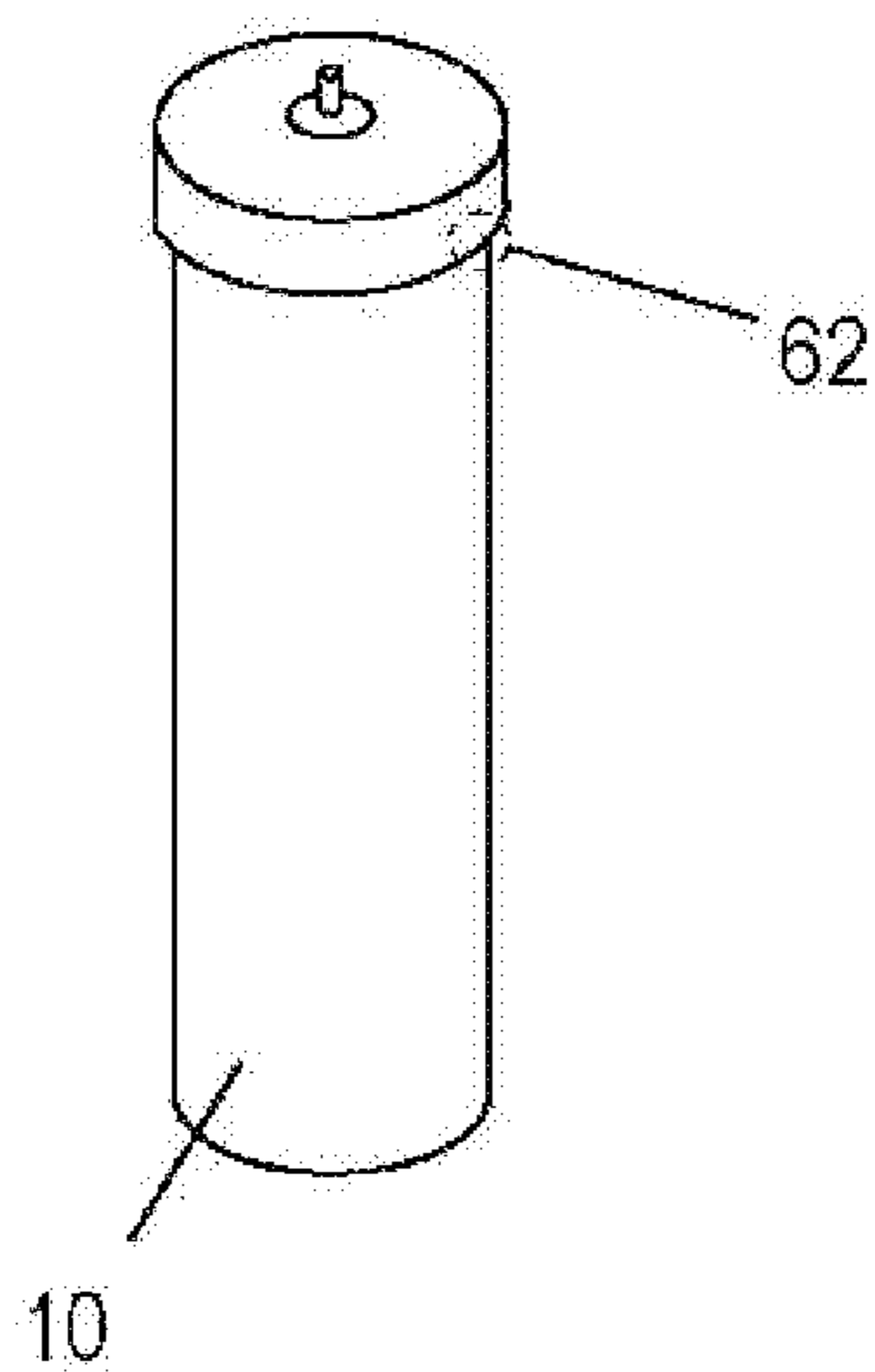

Fig. 23

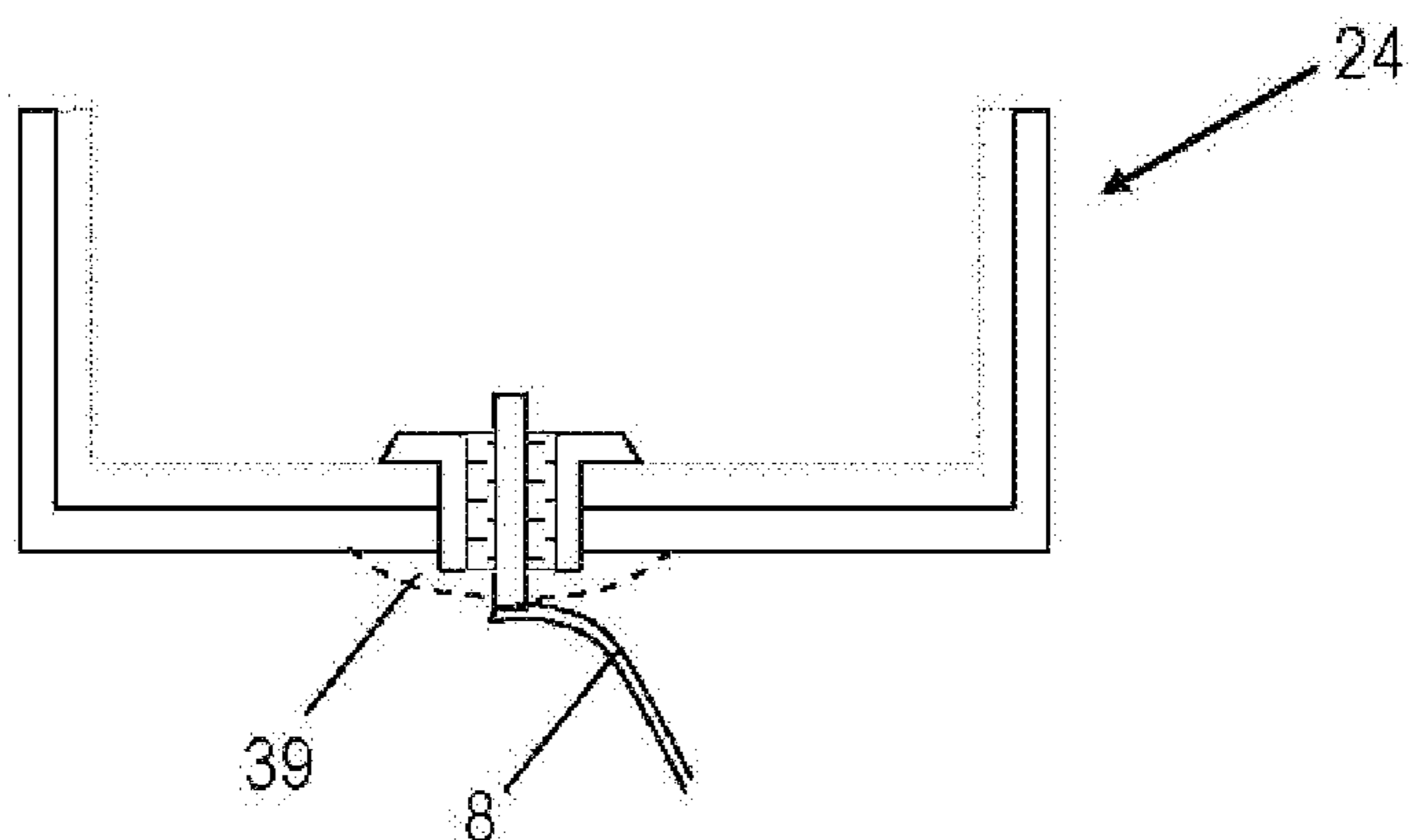

Fig. 24A

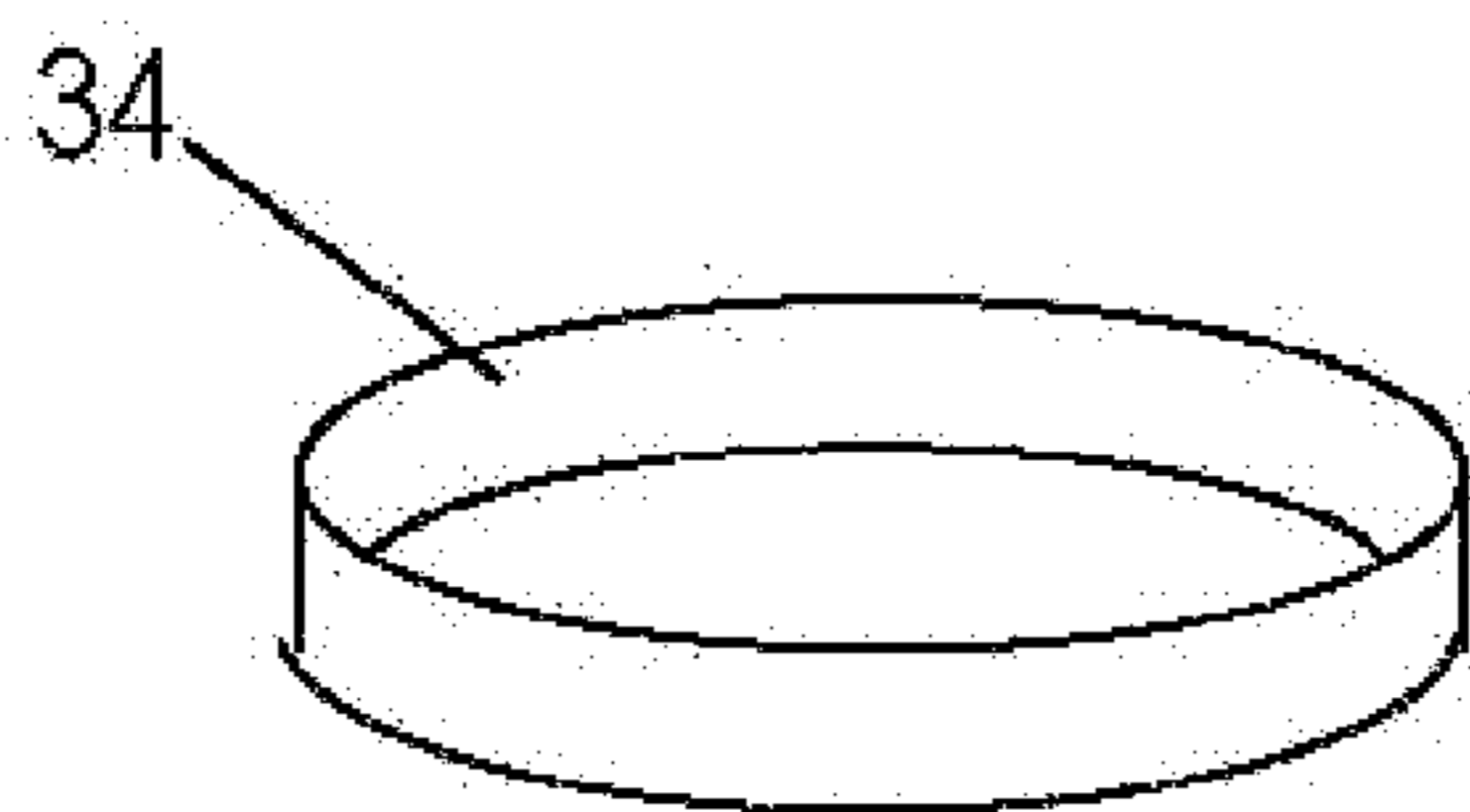

Fig. 24B

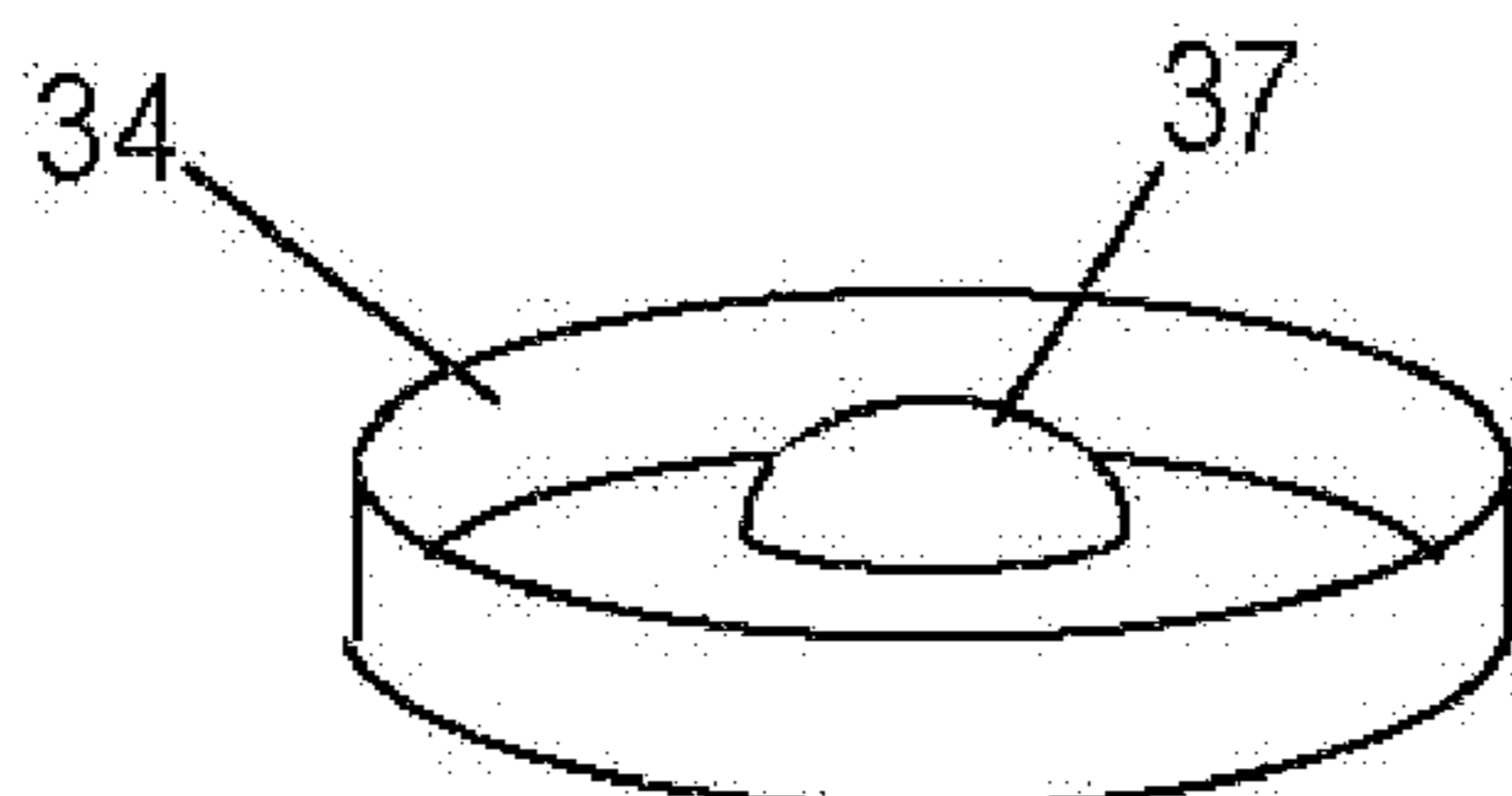

Fig. 24C

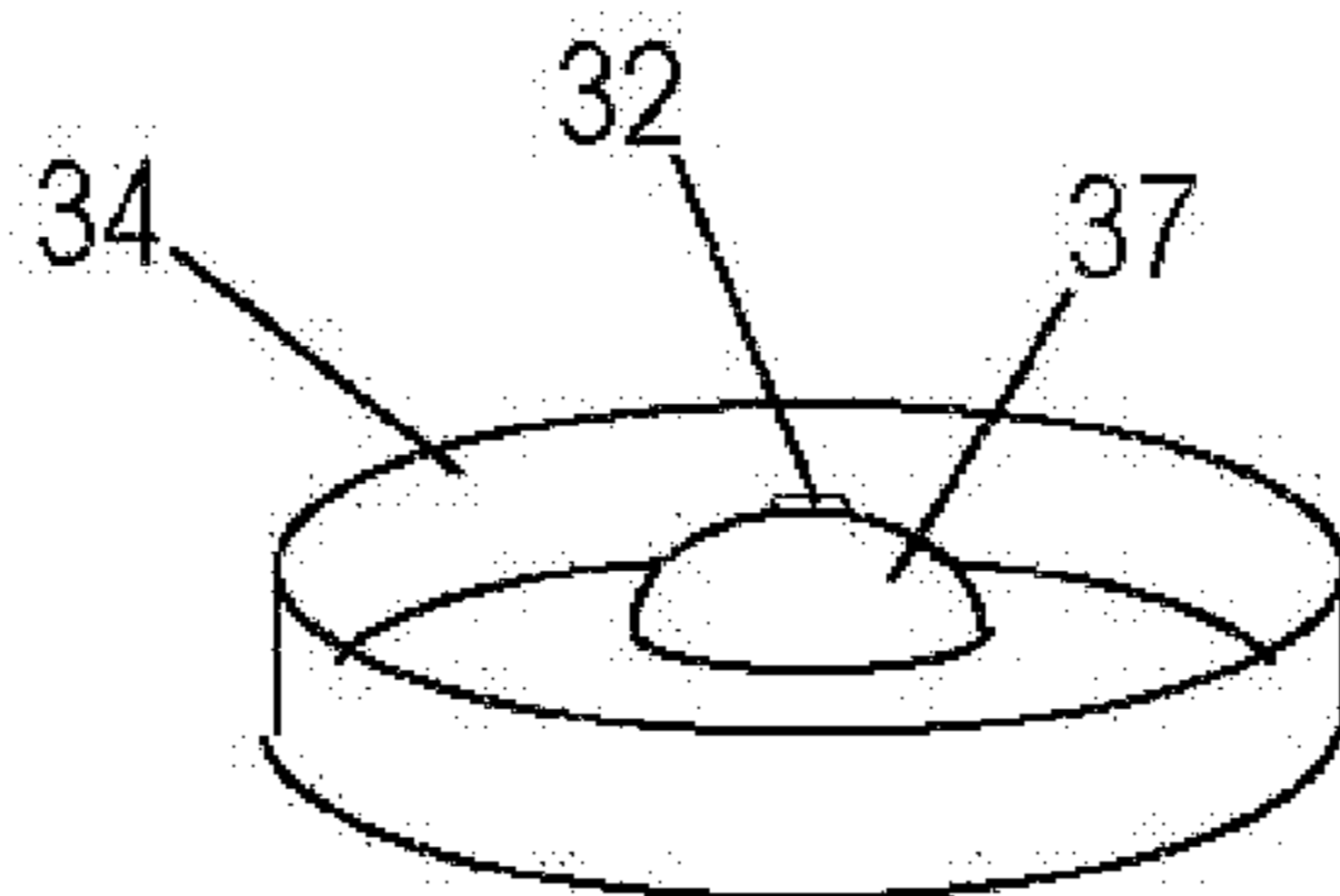

Fig. 25

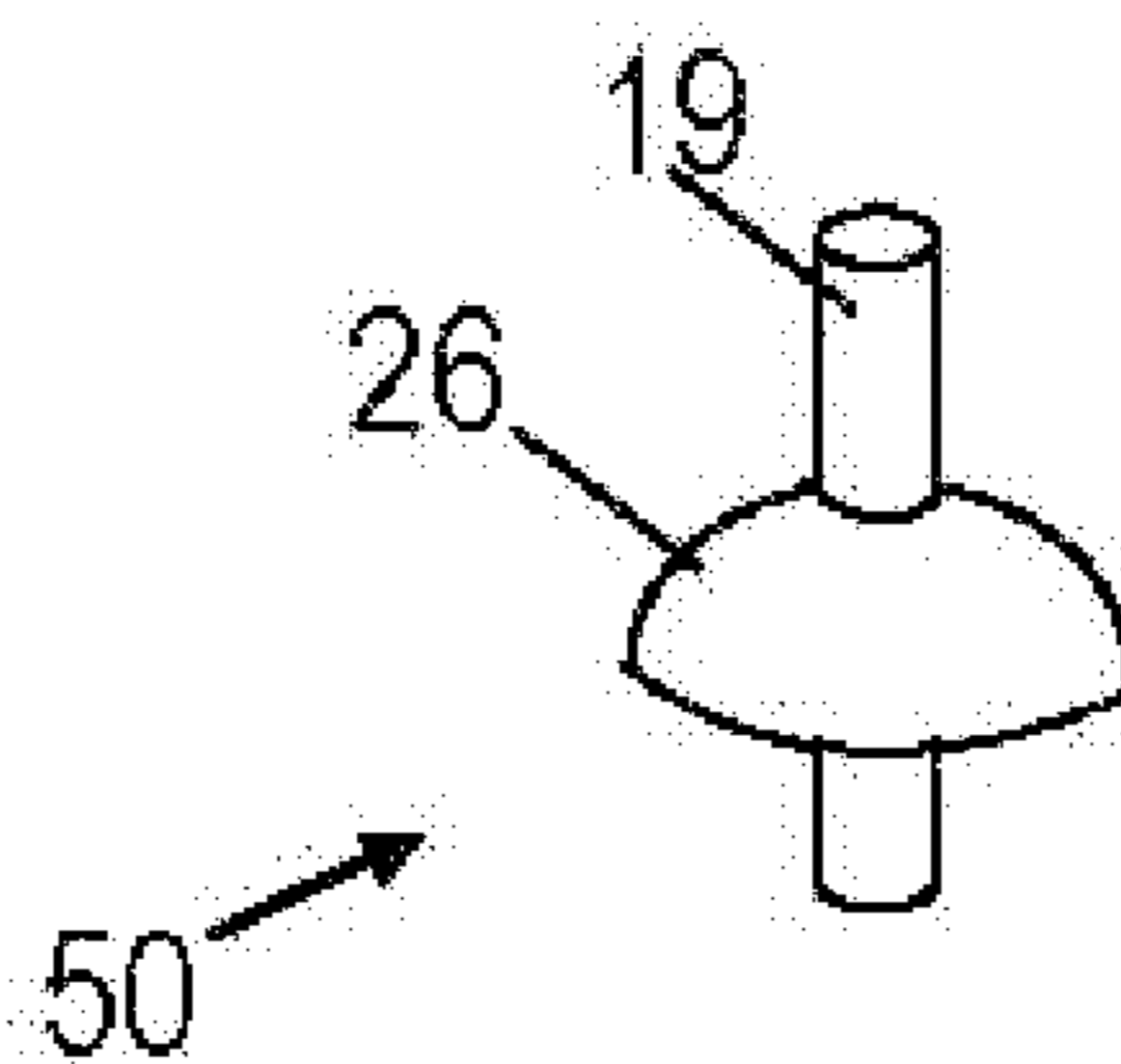

Fig. 26

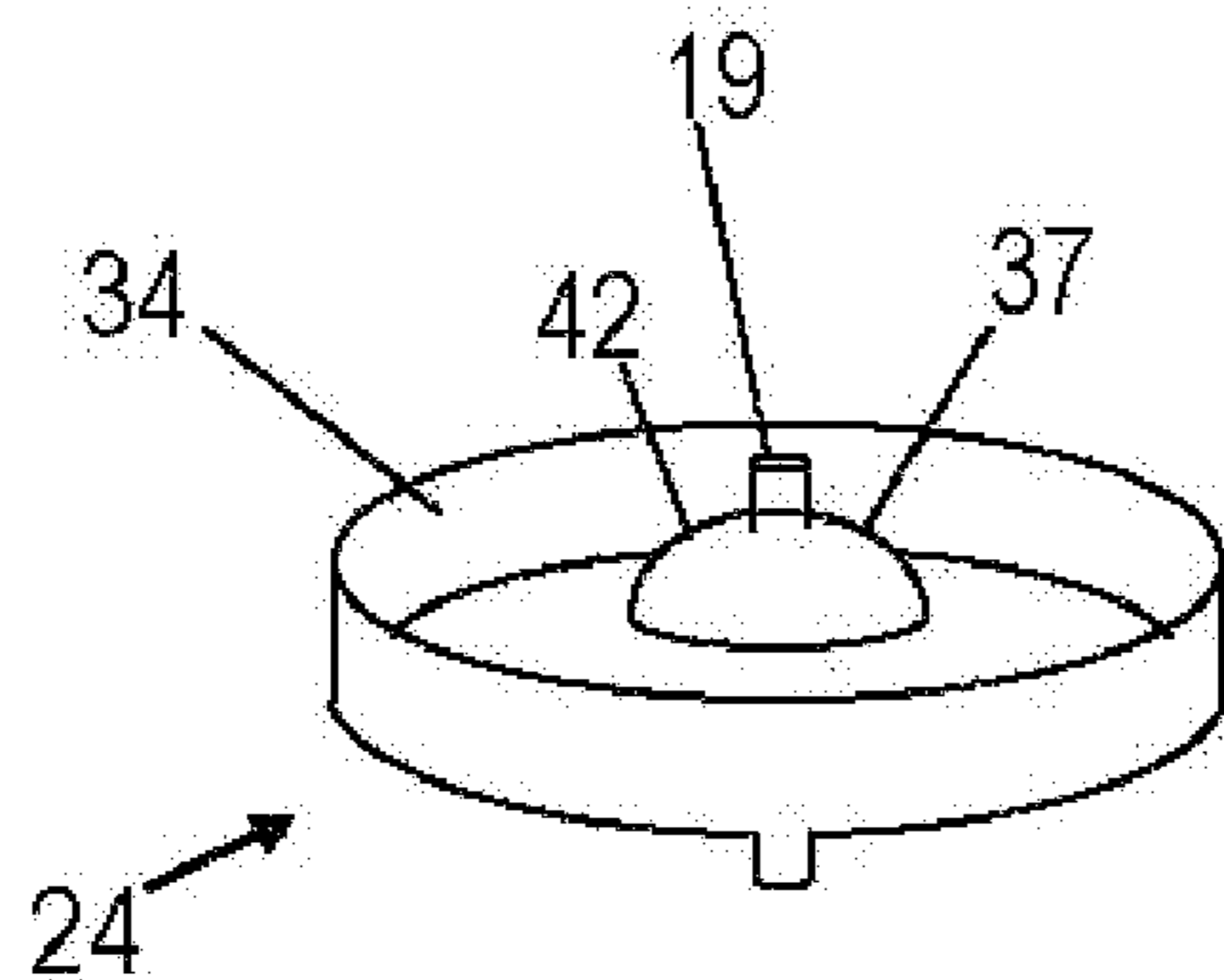

Fig. 27

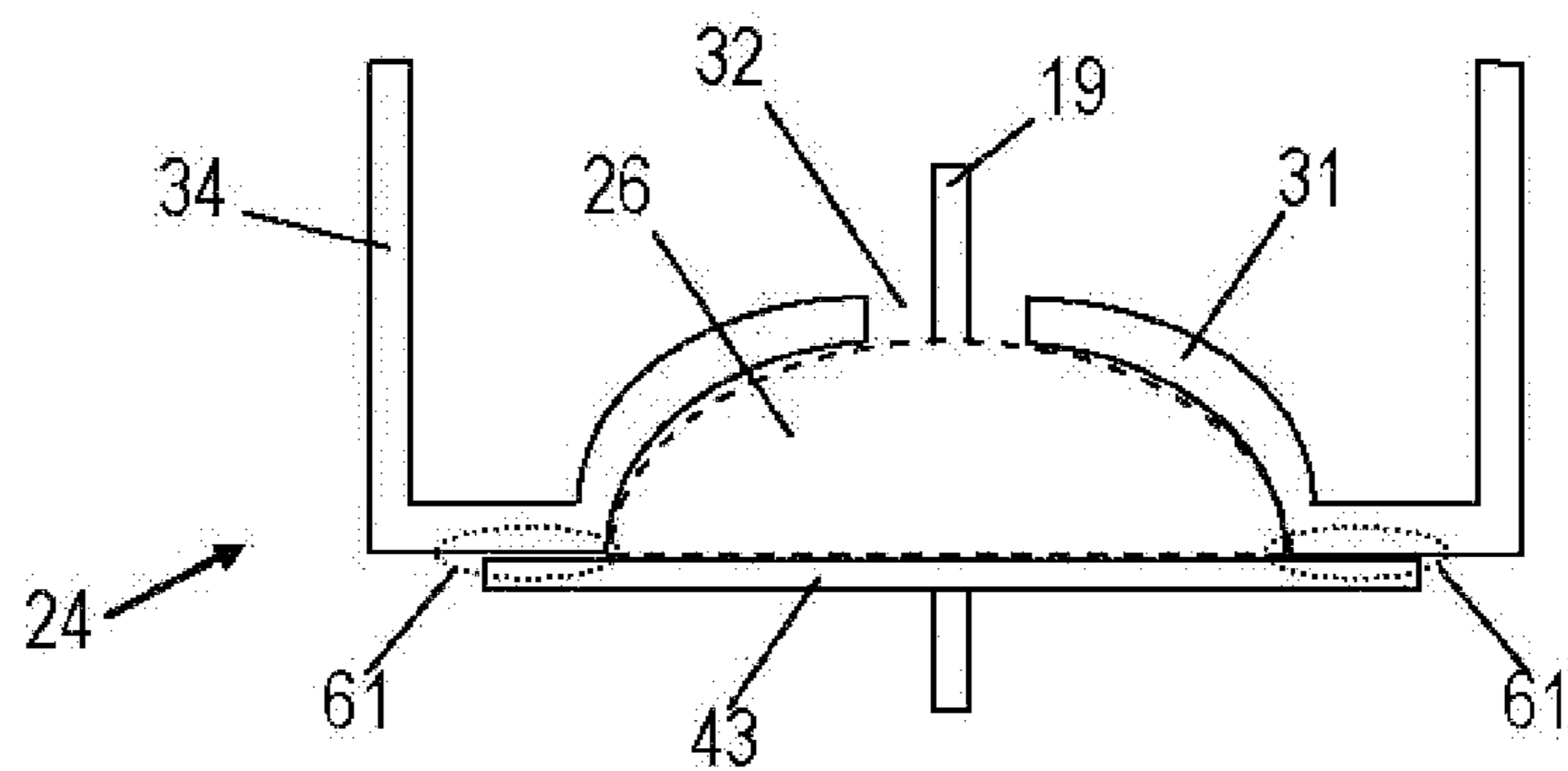

Fig. 28

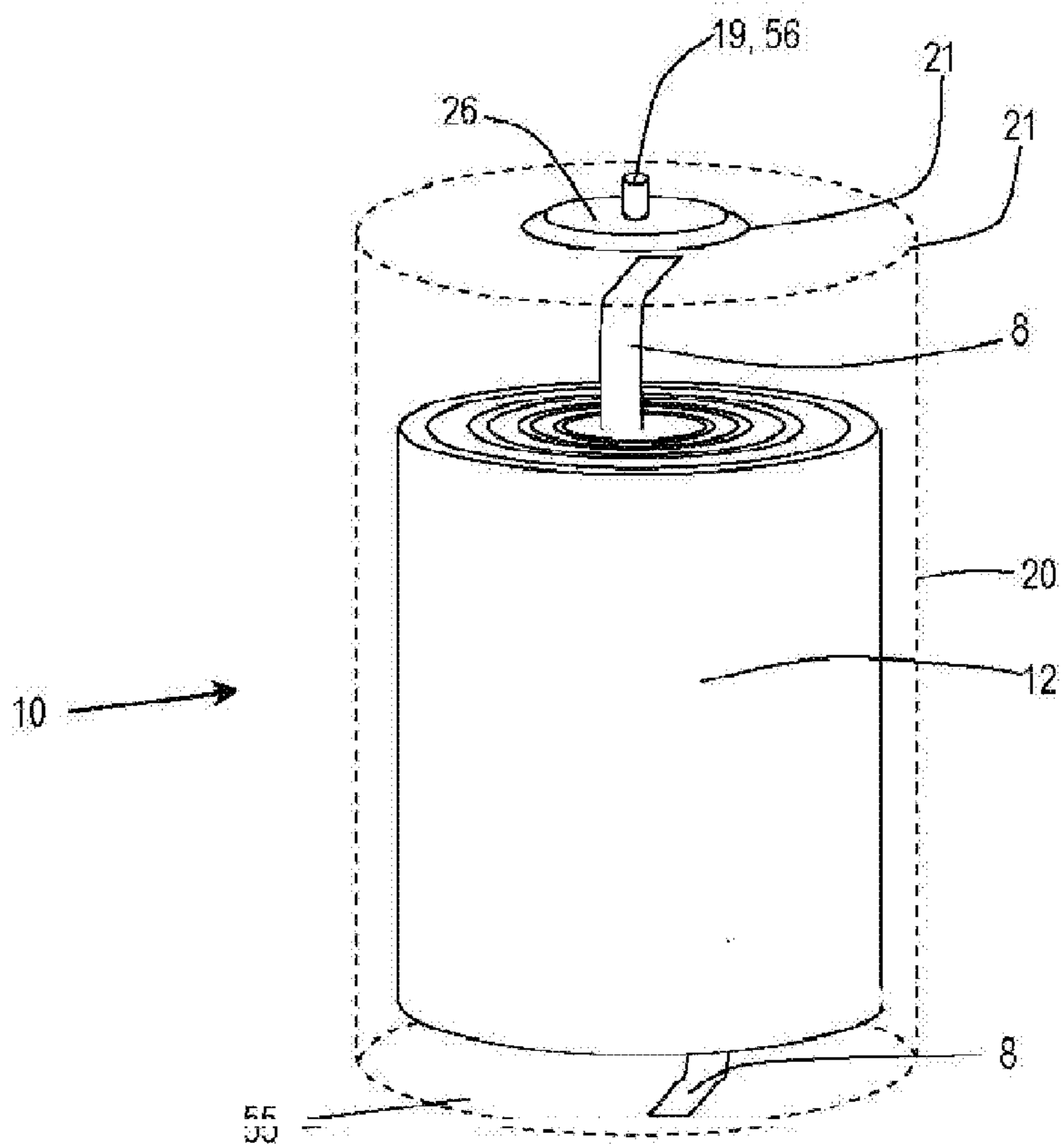

Fig. 29

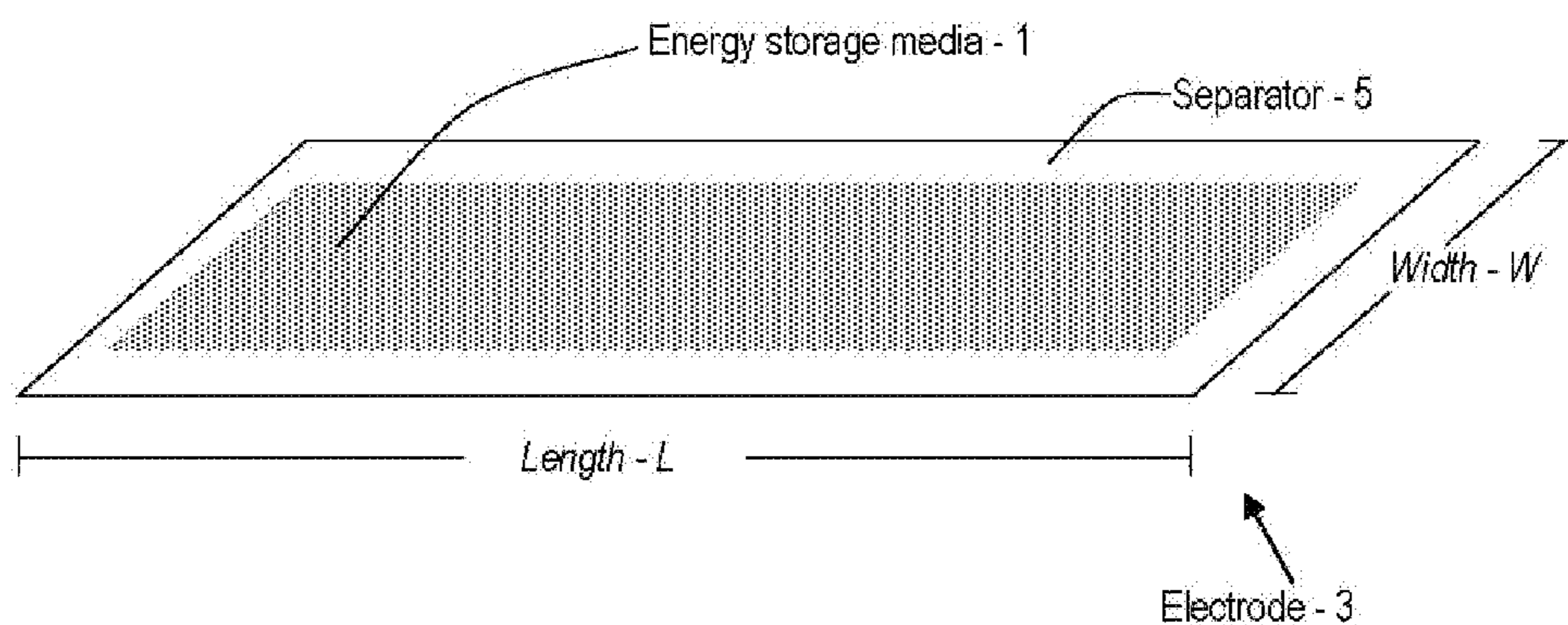

Fig. 30

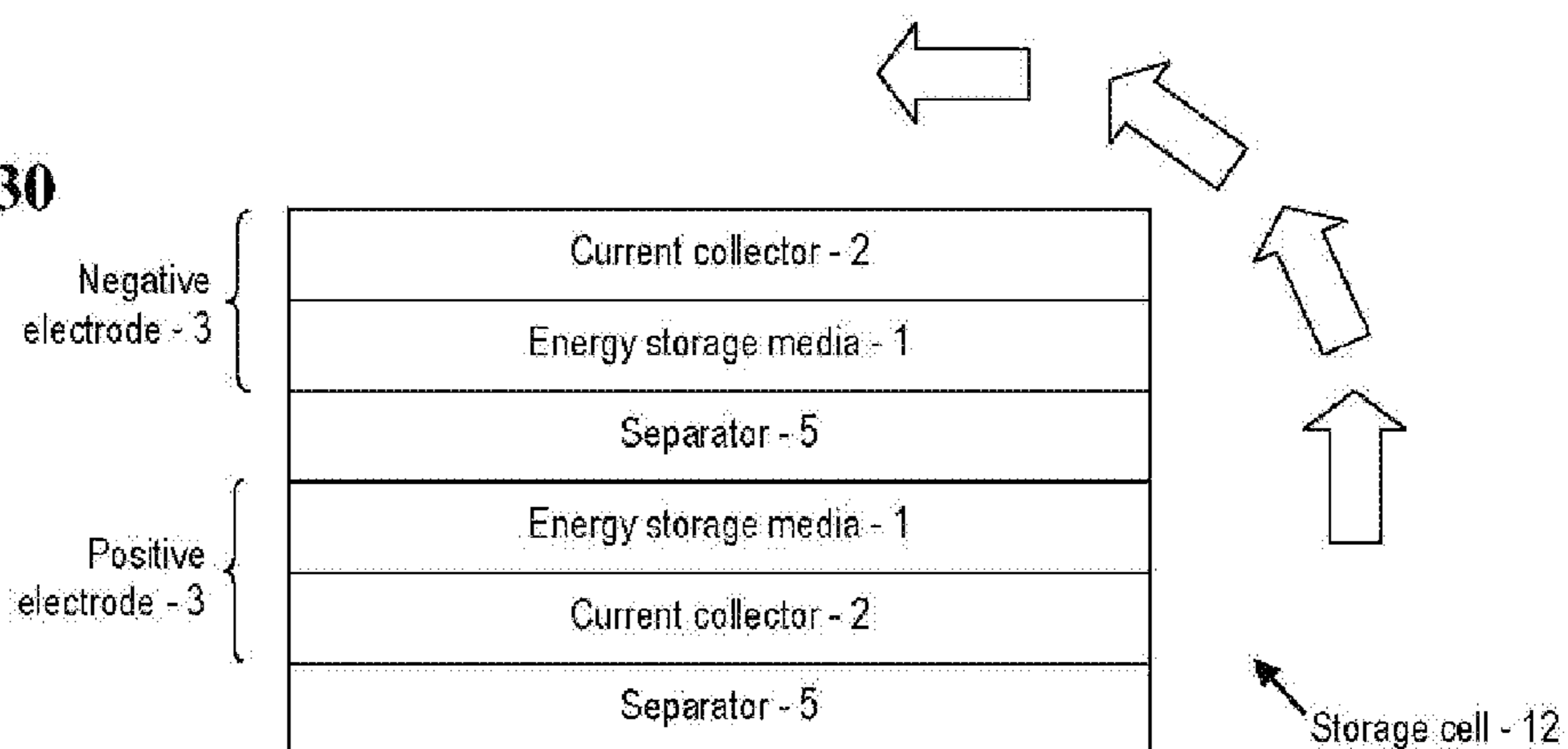

Fig. 31

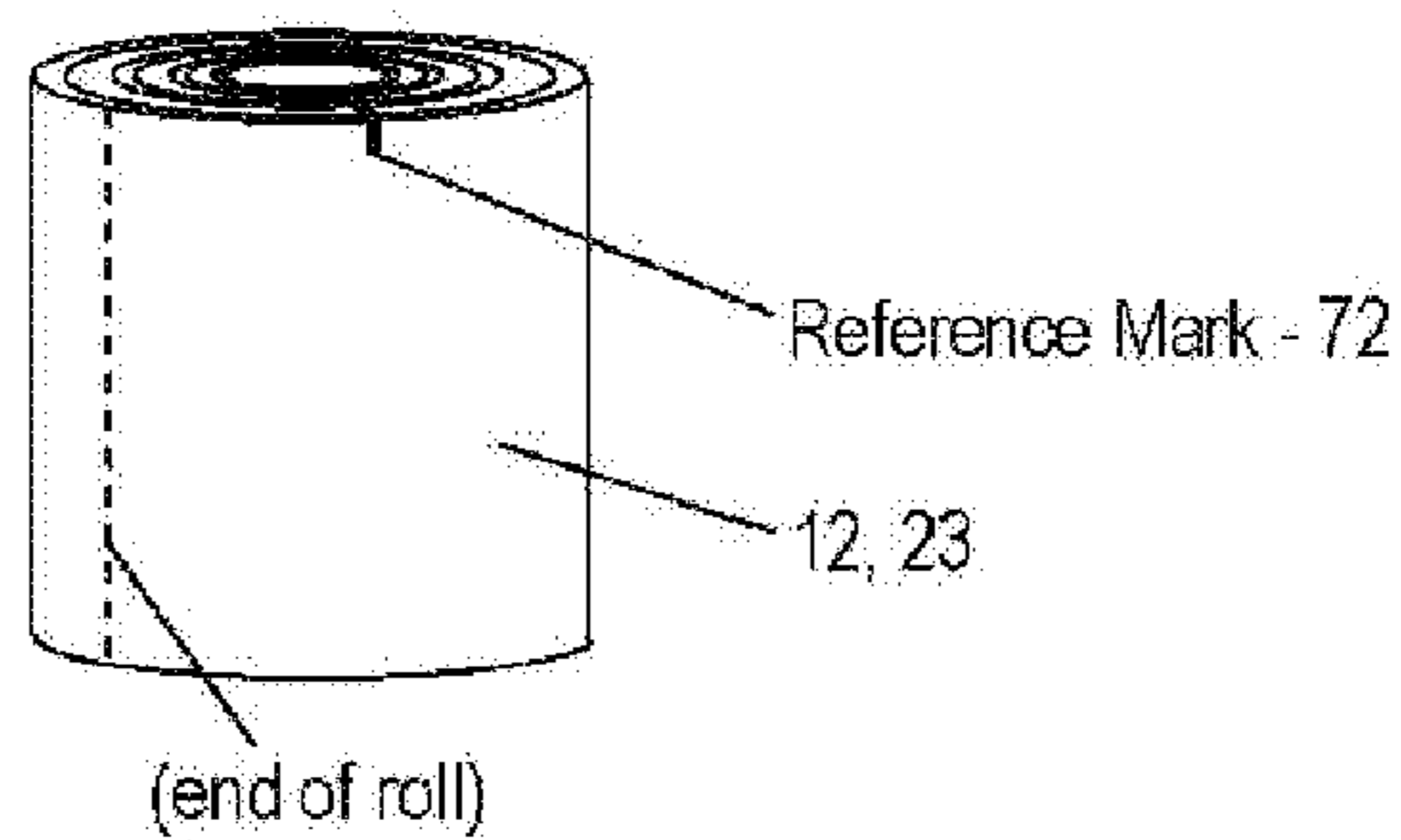

Fig. 32

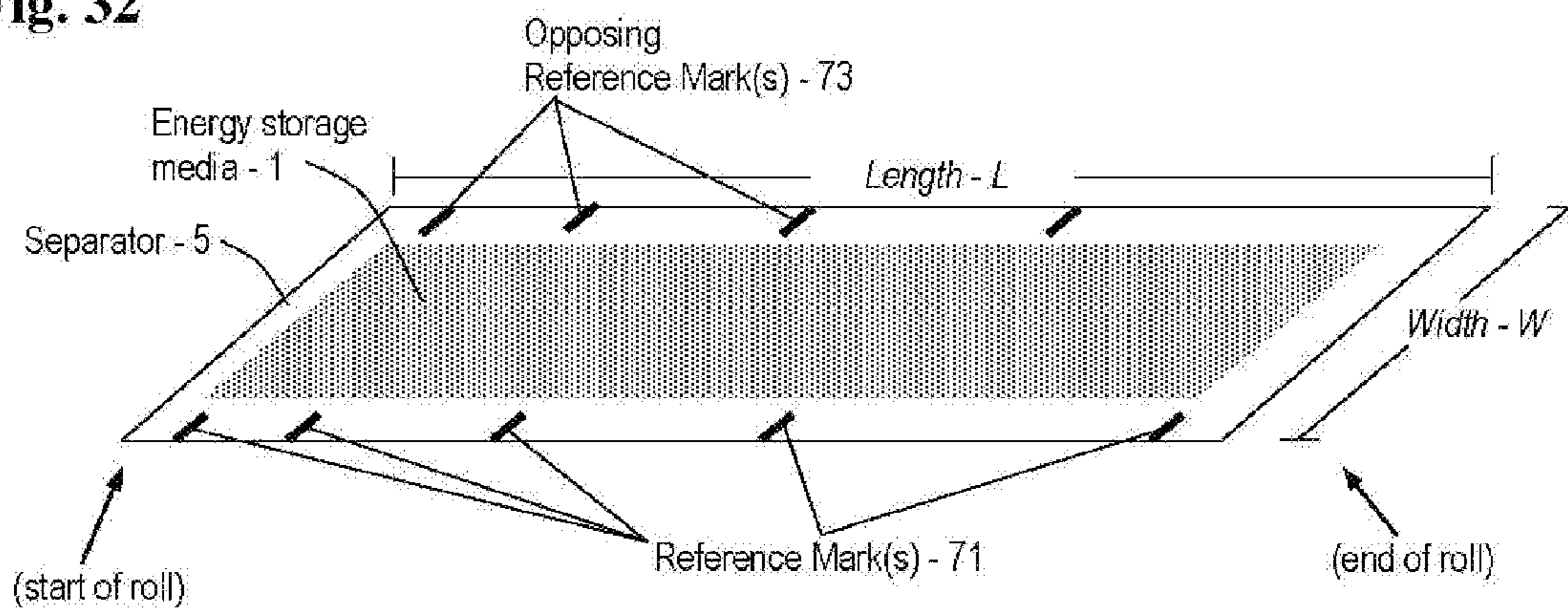

Fig. 33

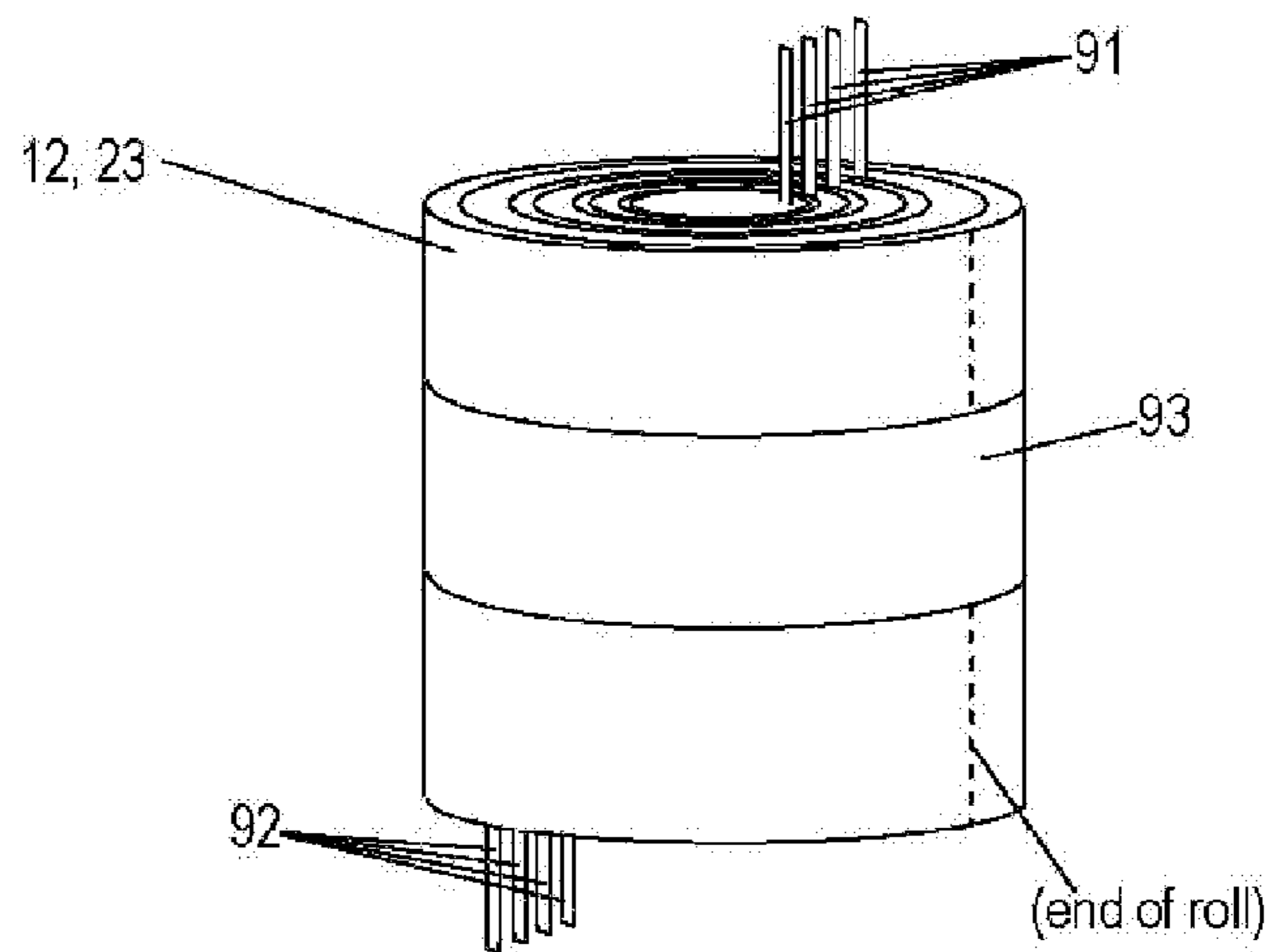

Fig. 34

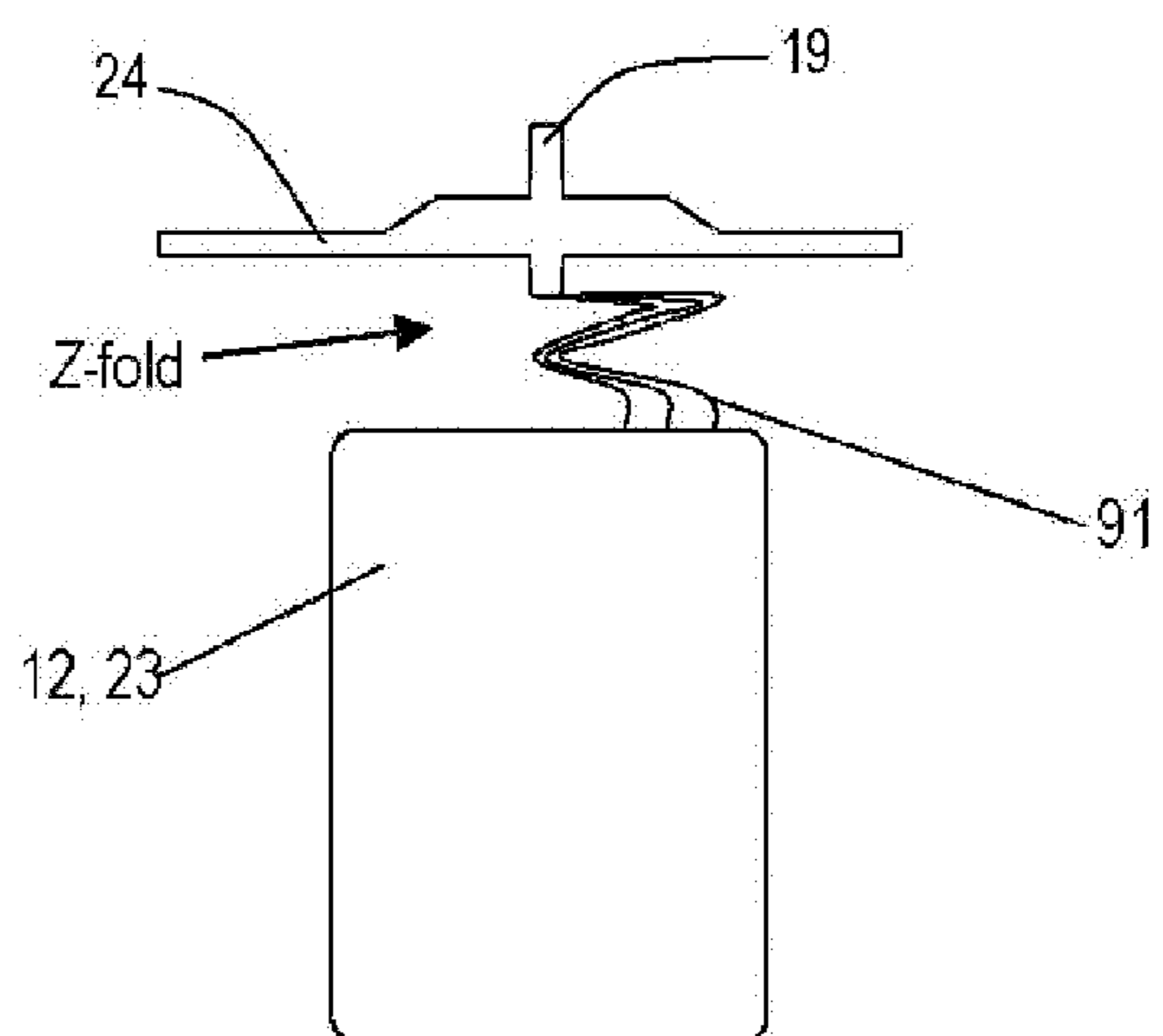

Fig. 35

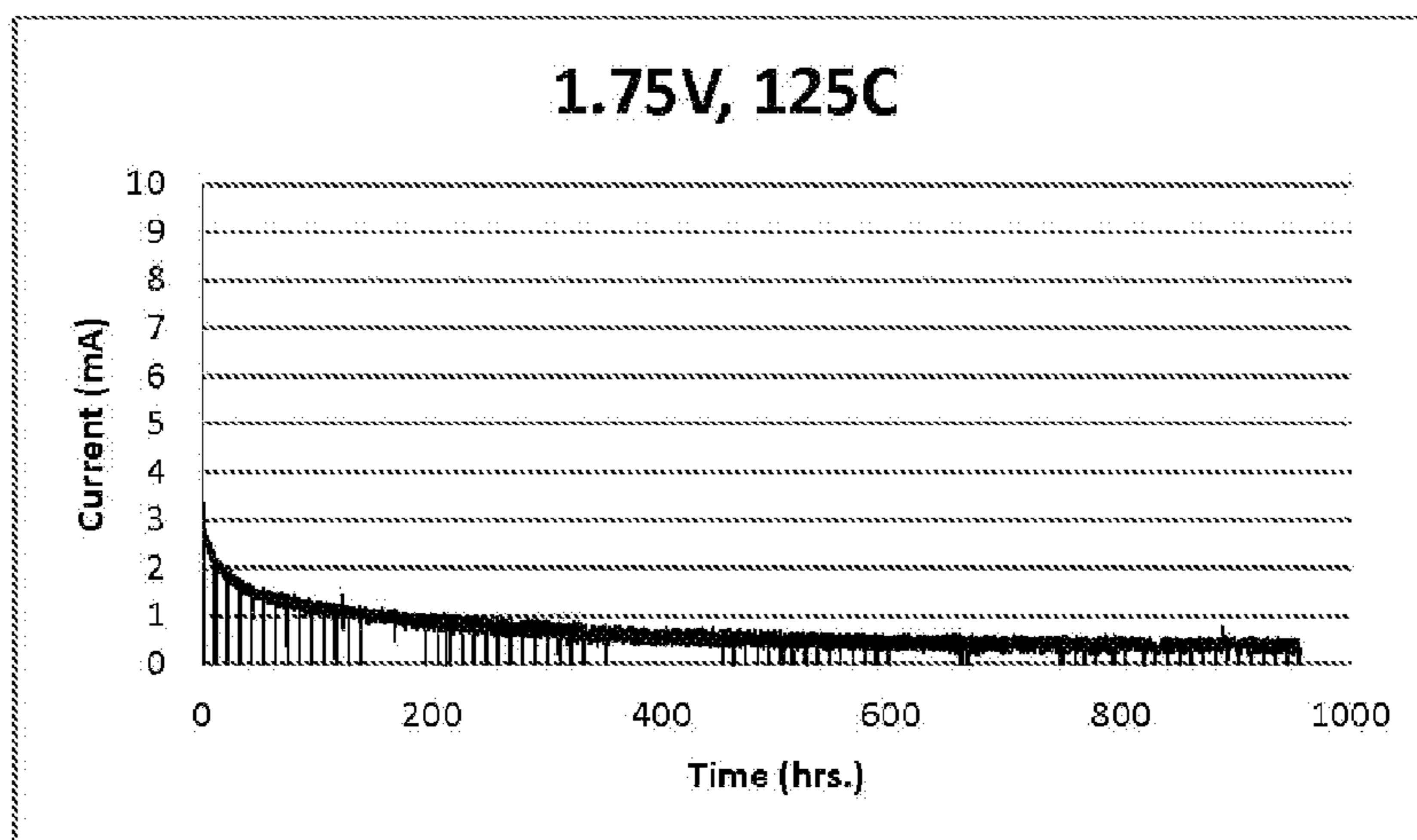

Fig. 36

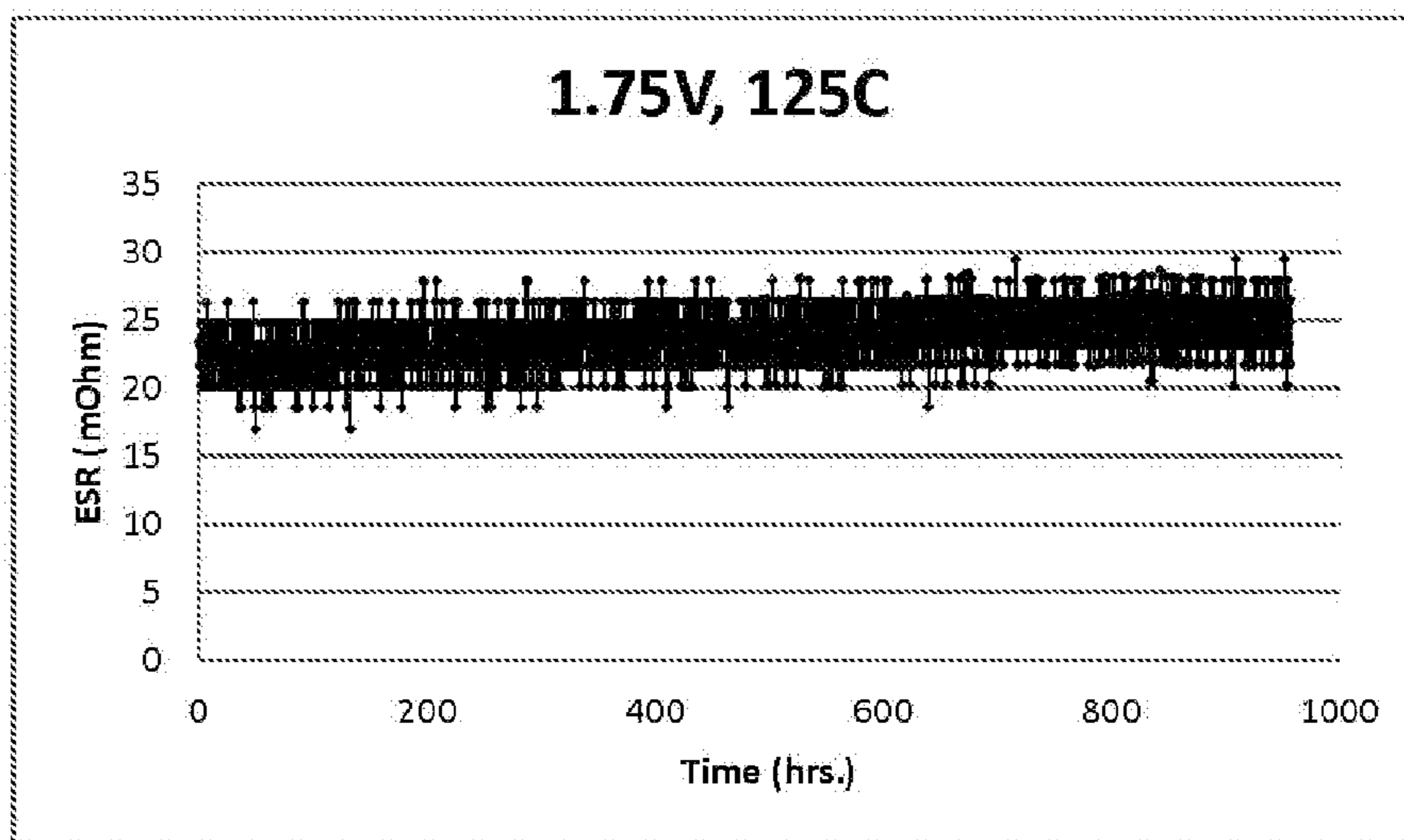

Fig. 37

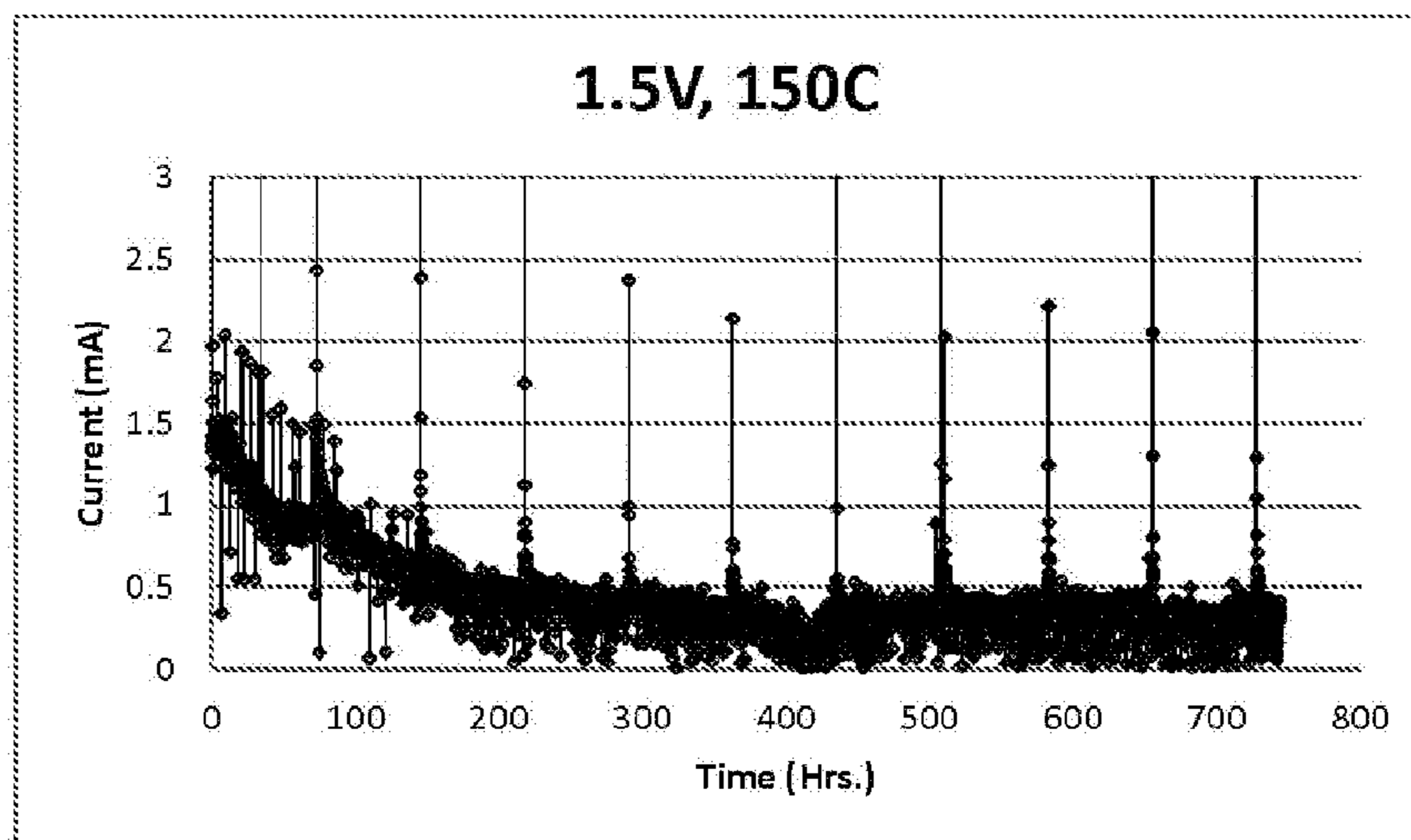

Fig. 38

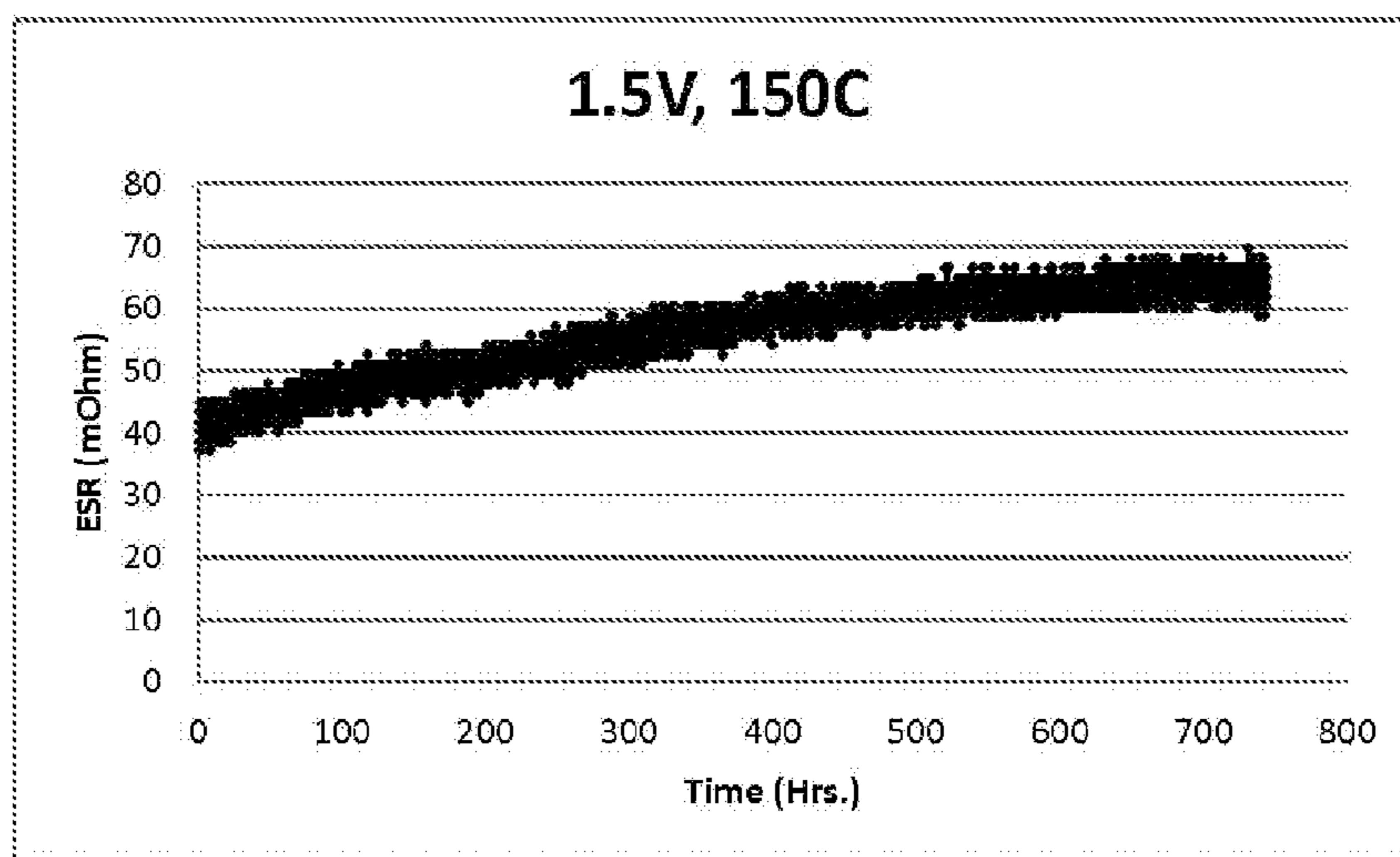

Fig. 39

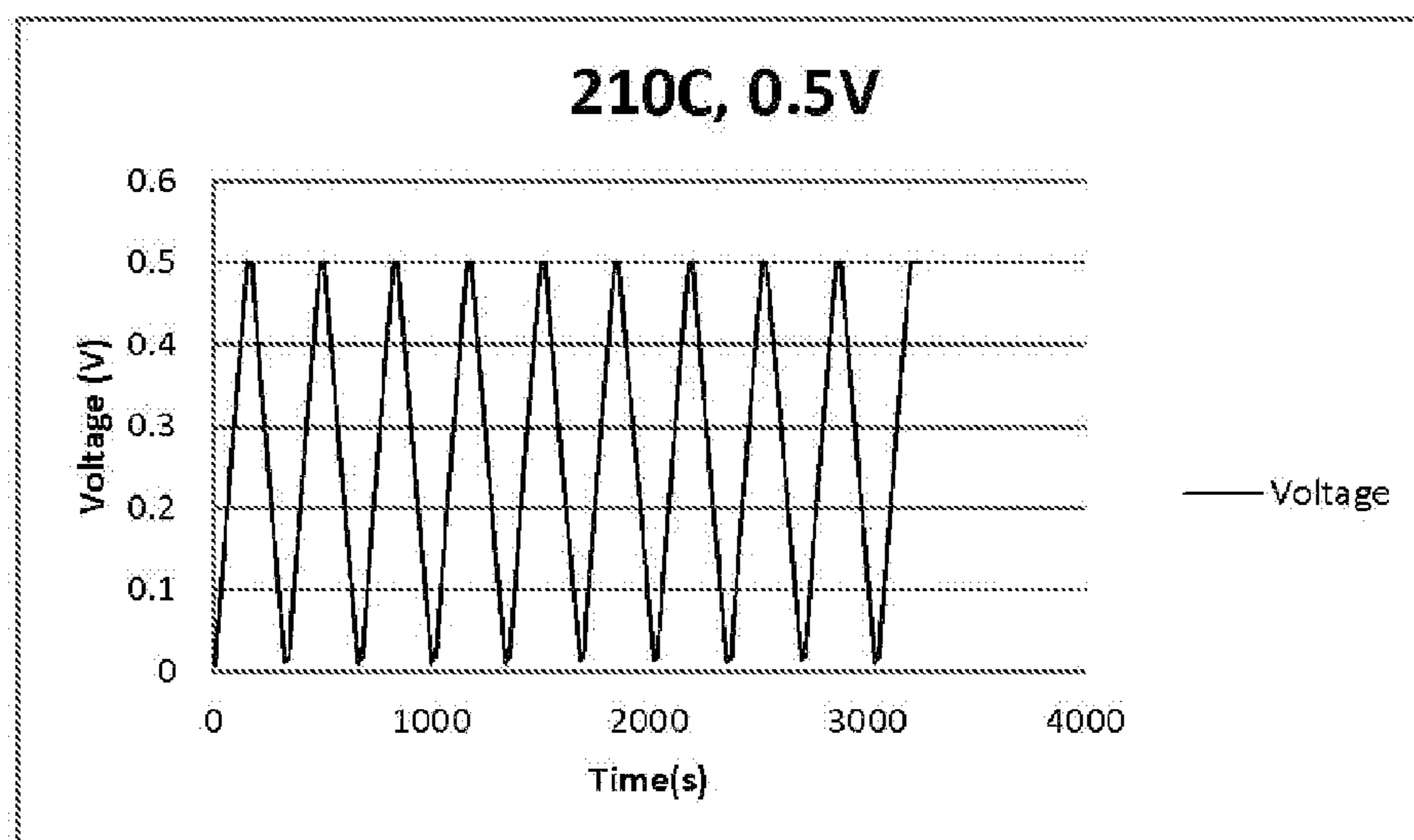

Fig. 40

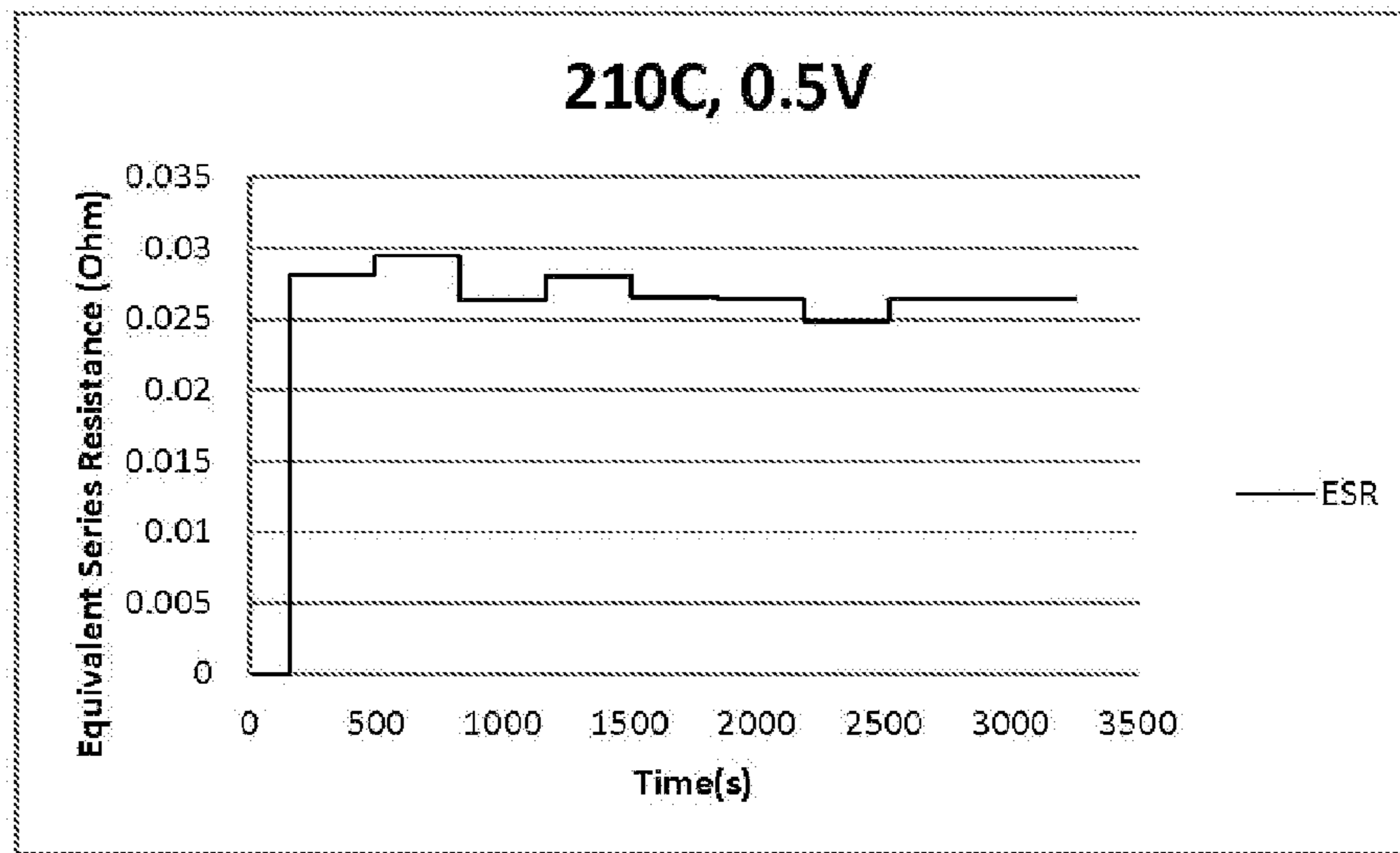

Fig. 41

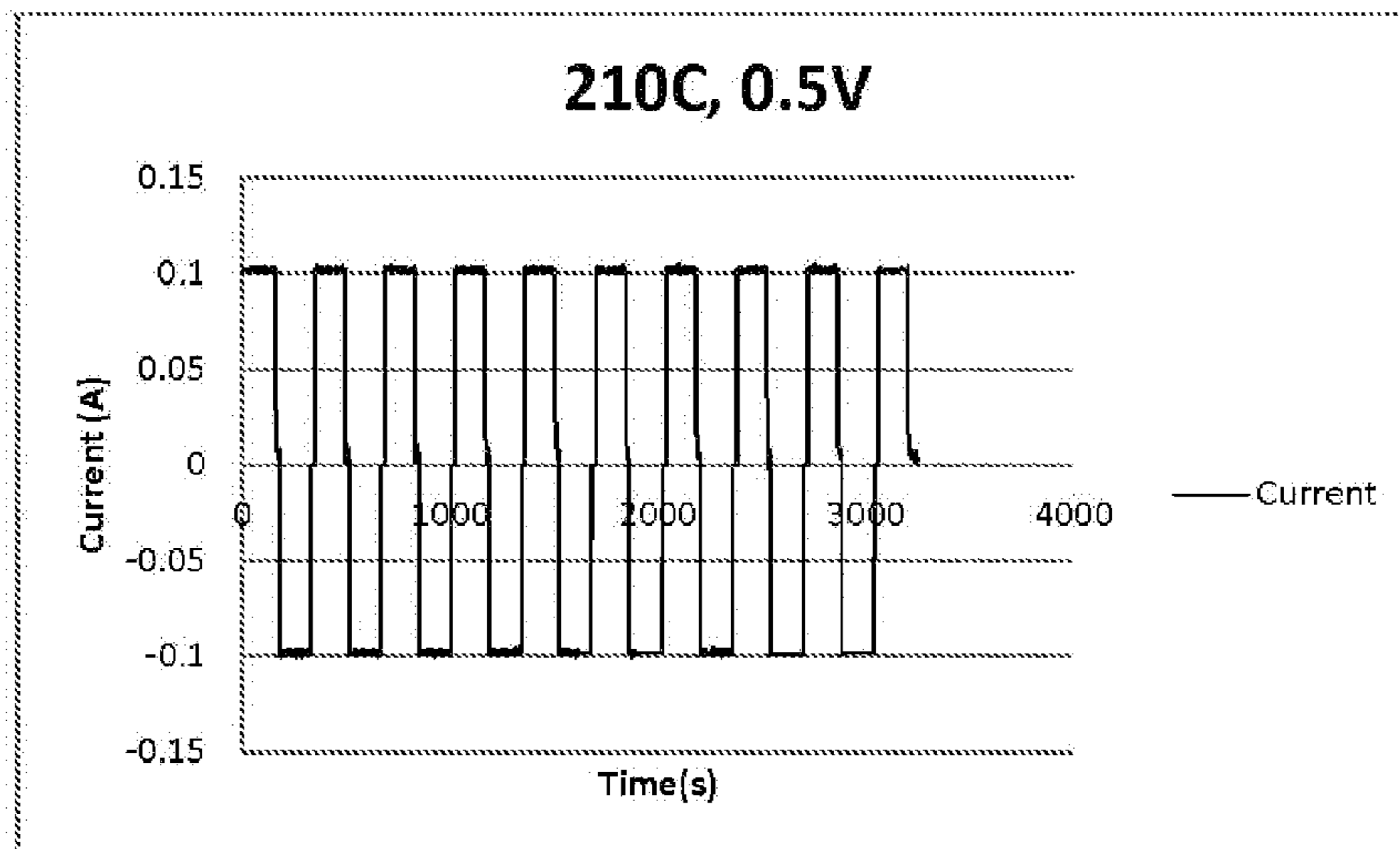

Fig. 42

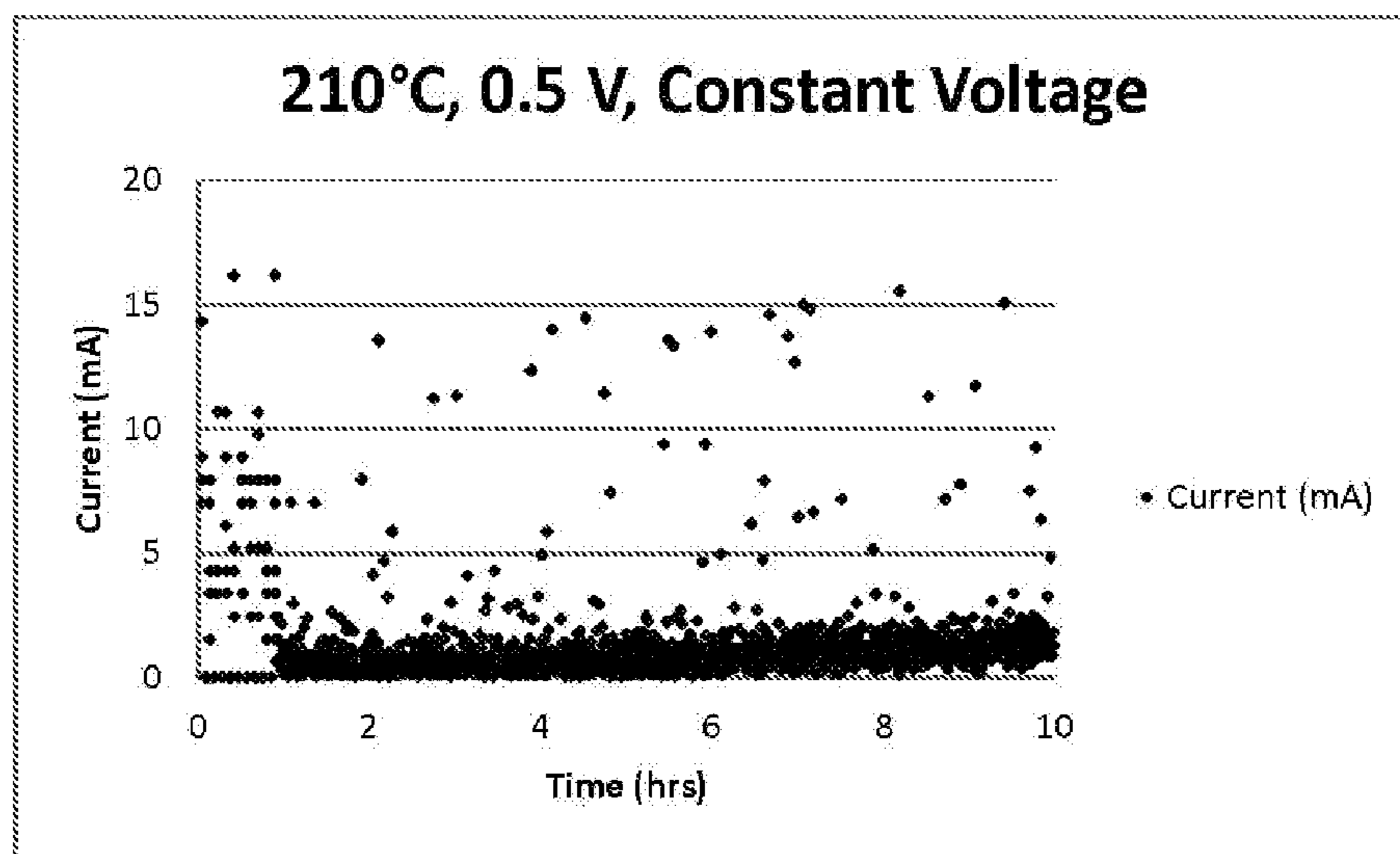

Fig. 43

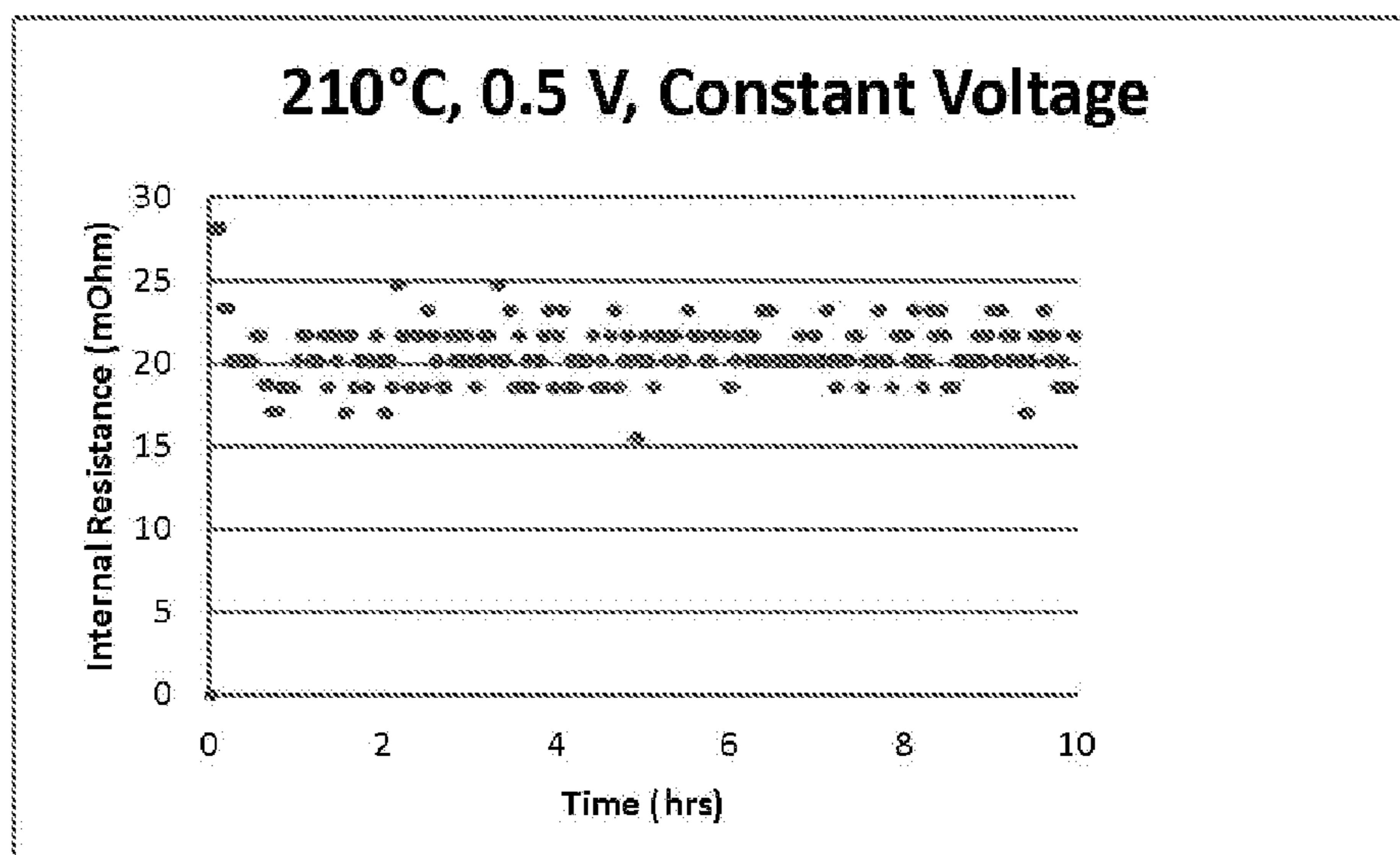

Fig. 44A

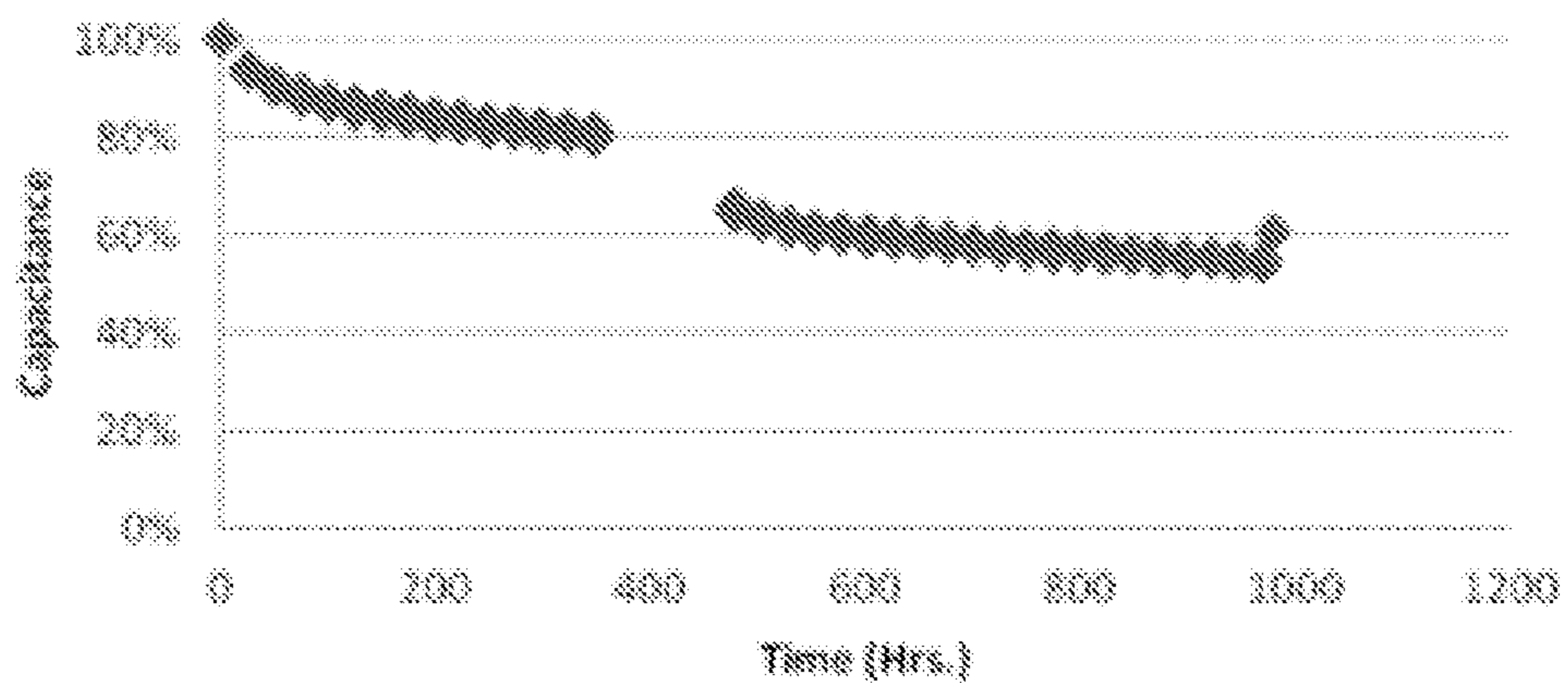

Fig. 44B

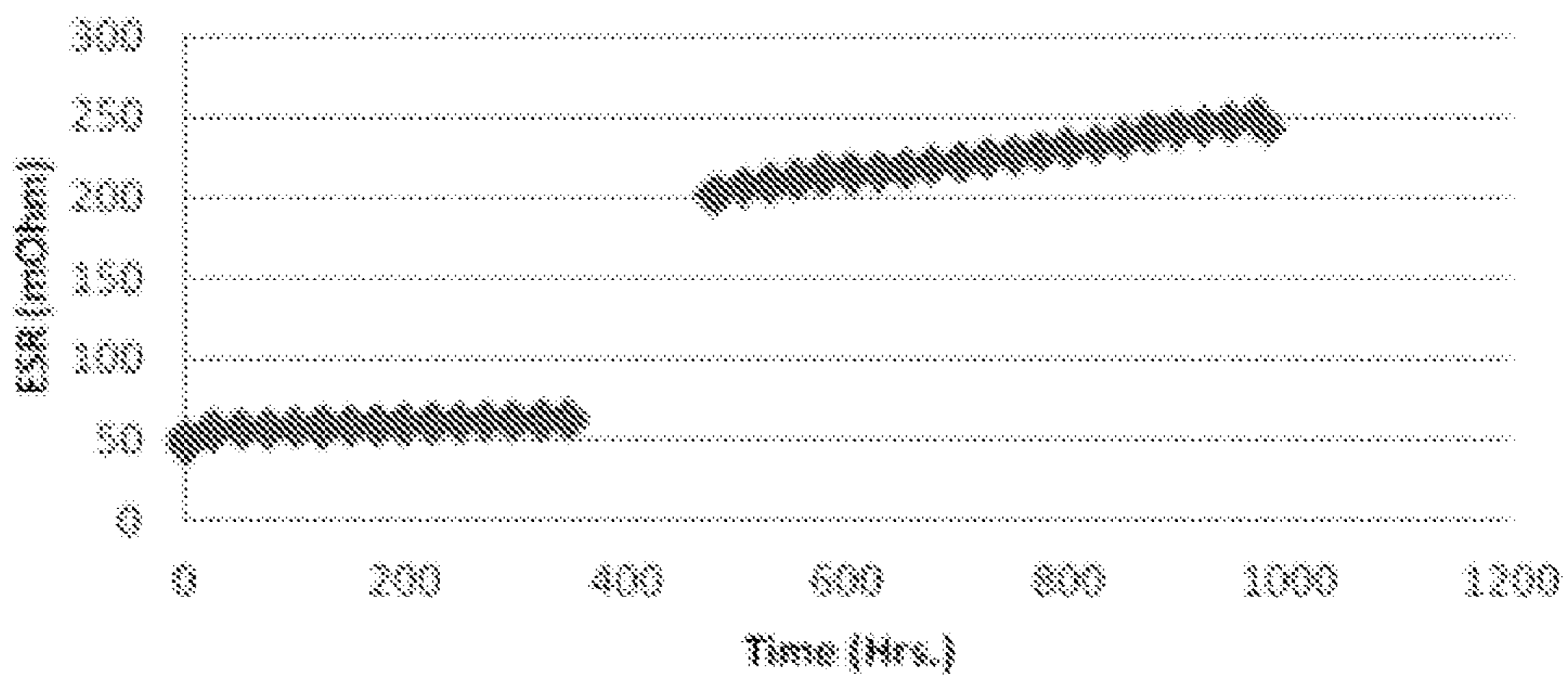

Fig. 45A

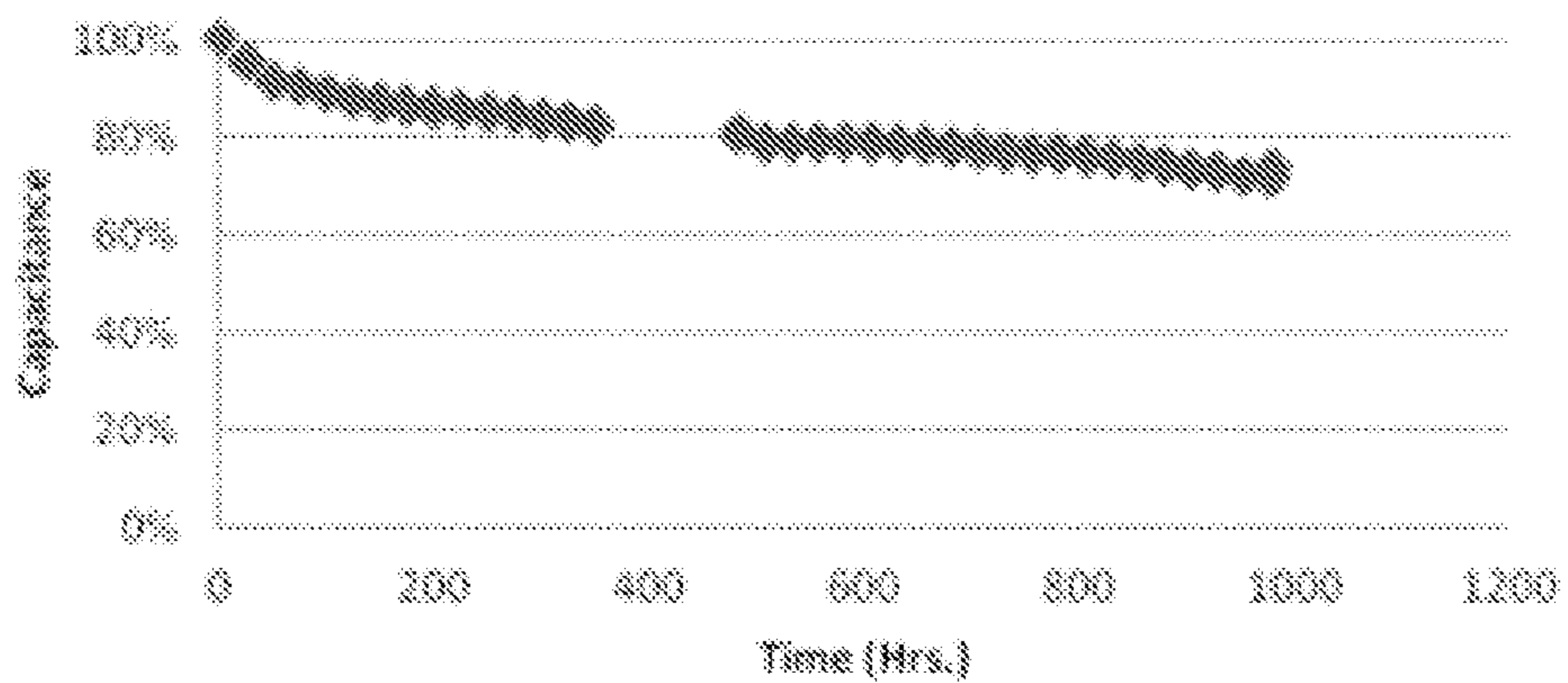

Fig. 45B

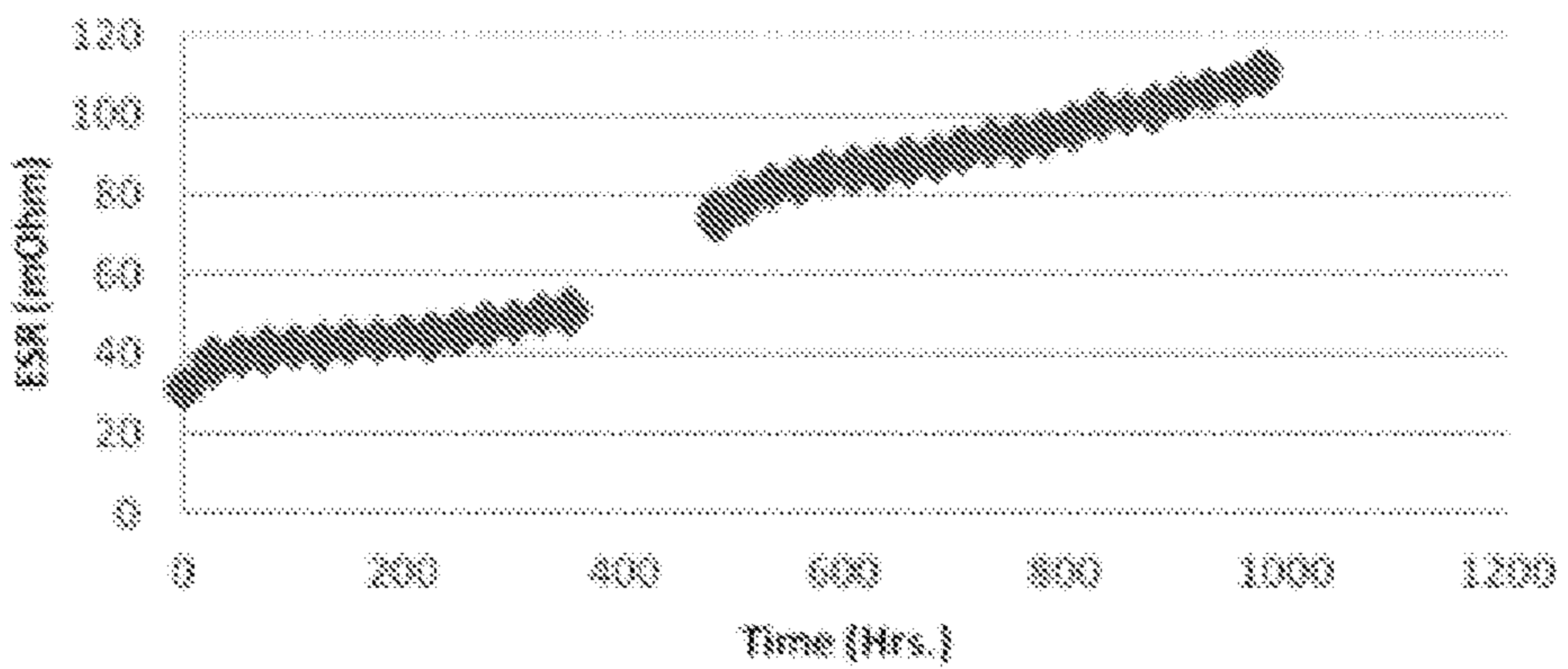

Fig. 46A

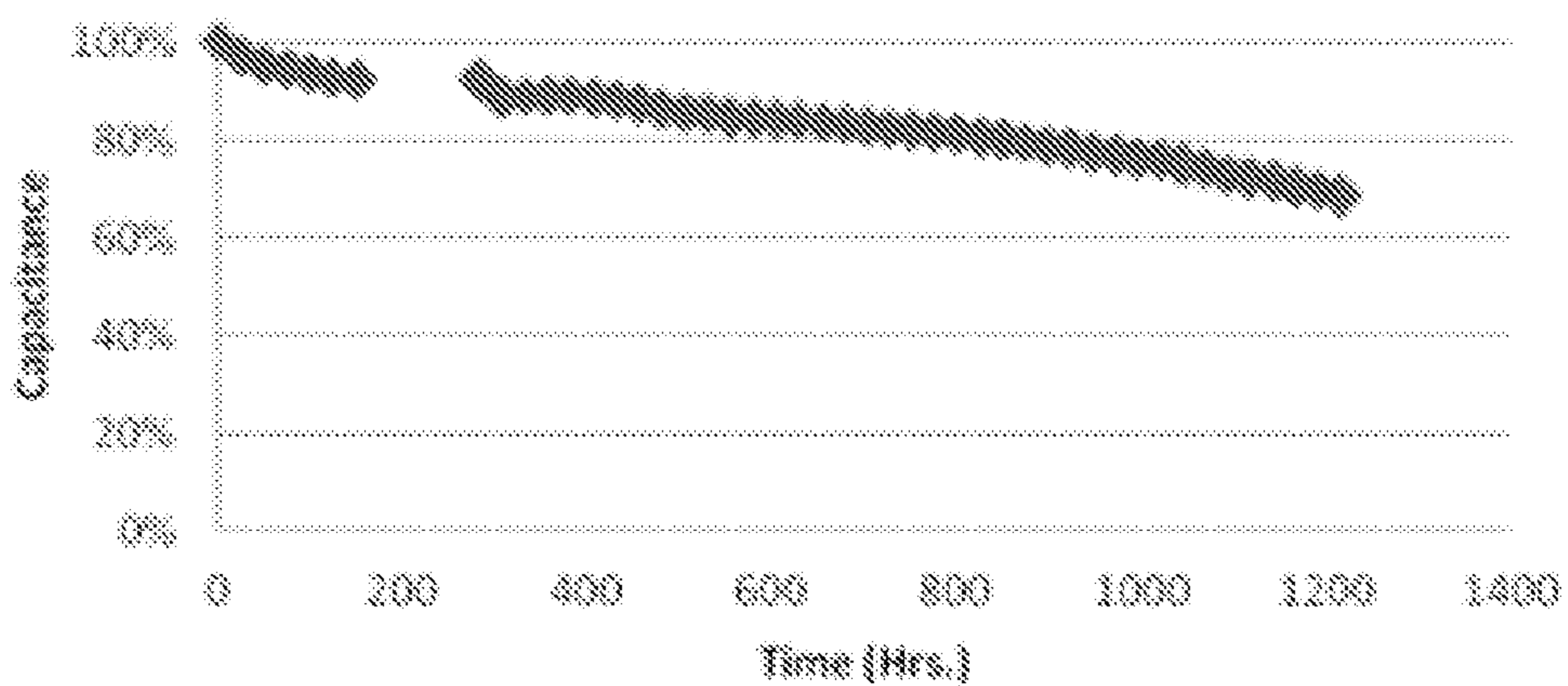

Fig. 46B

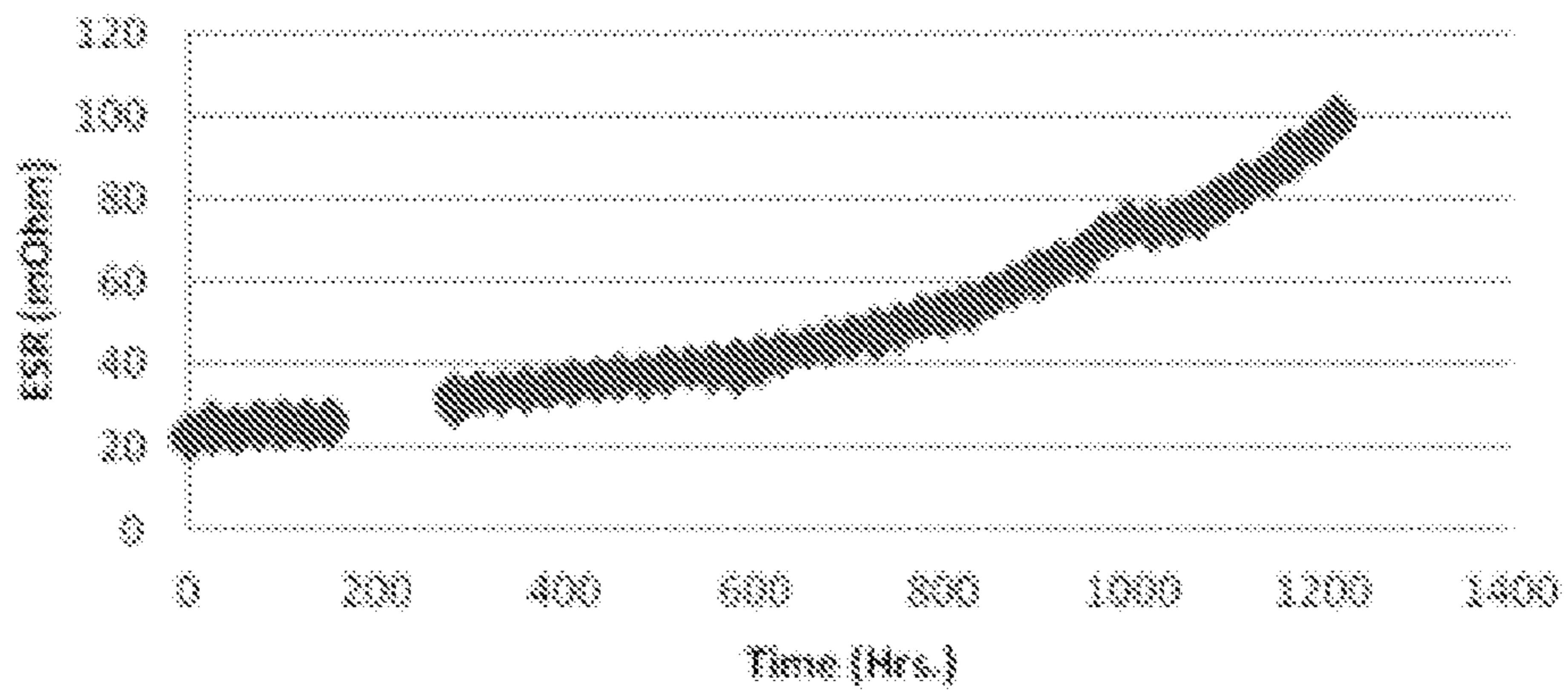

Fig. 47A

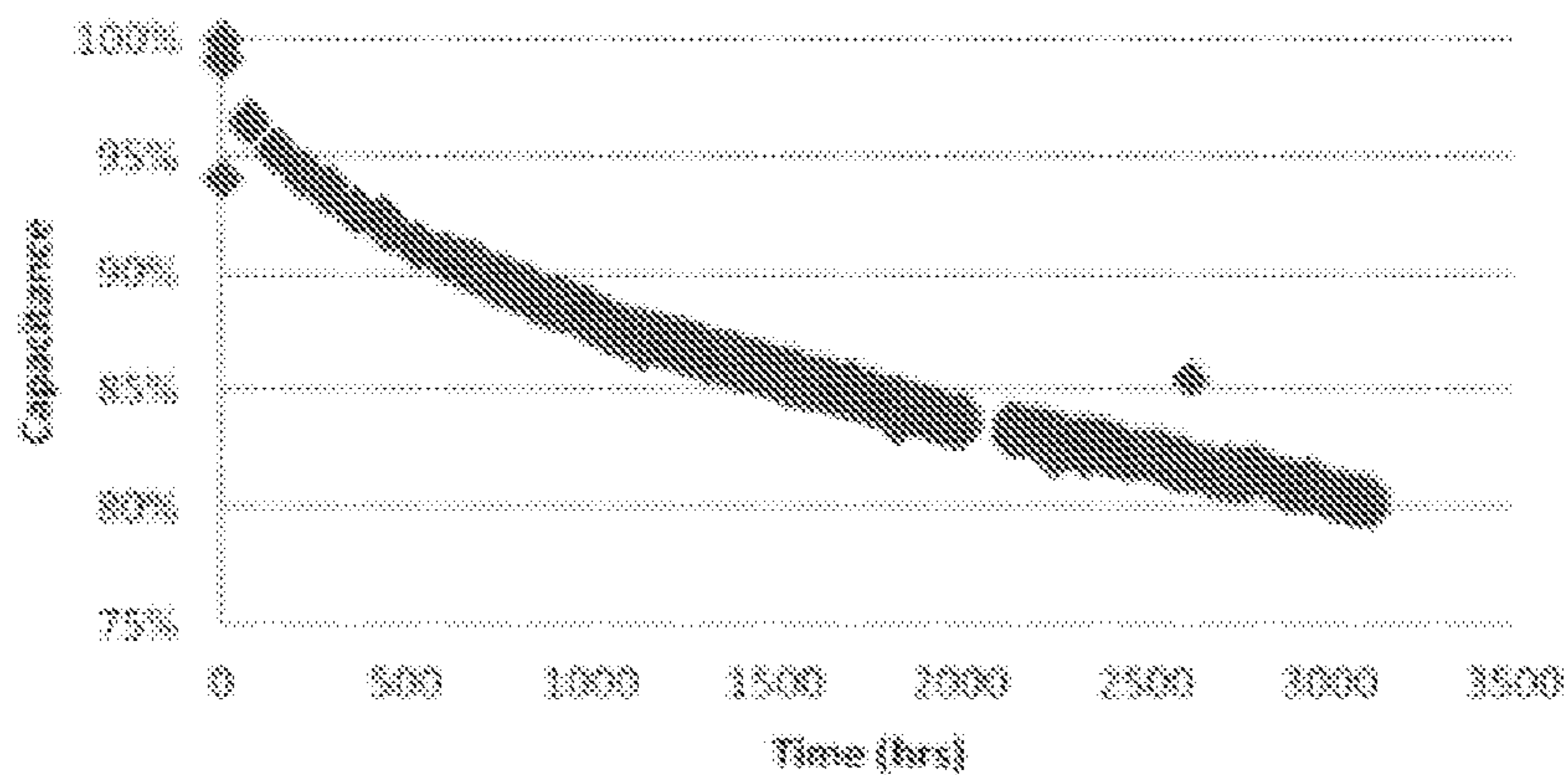

Fig. 47B

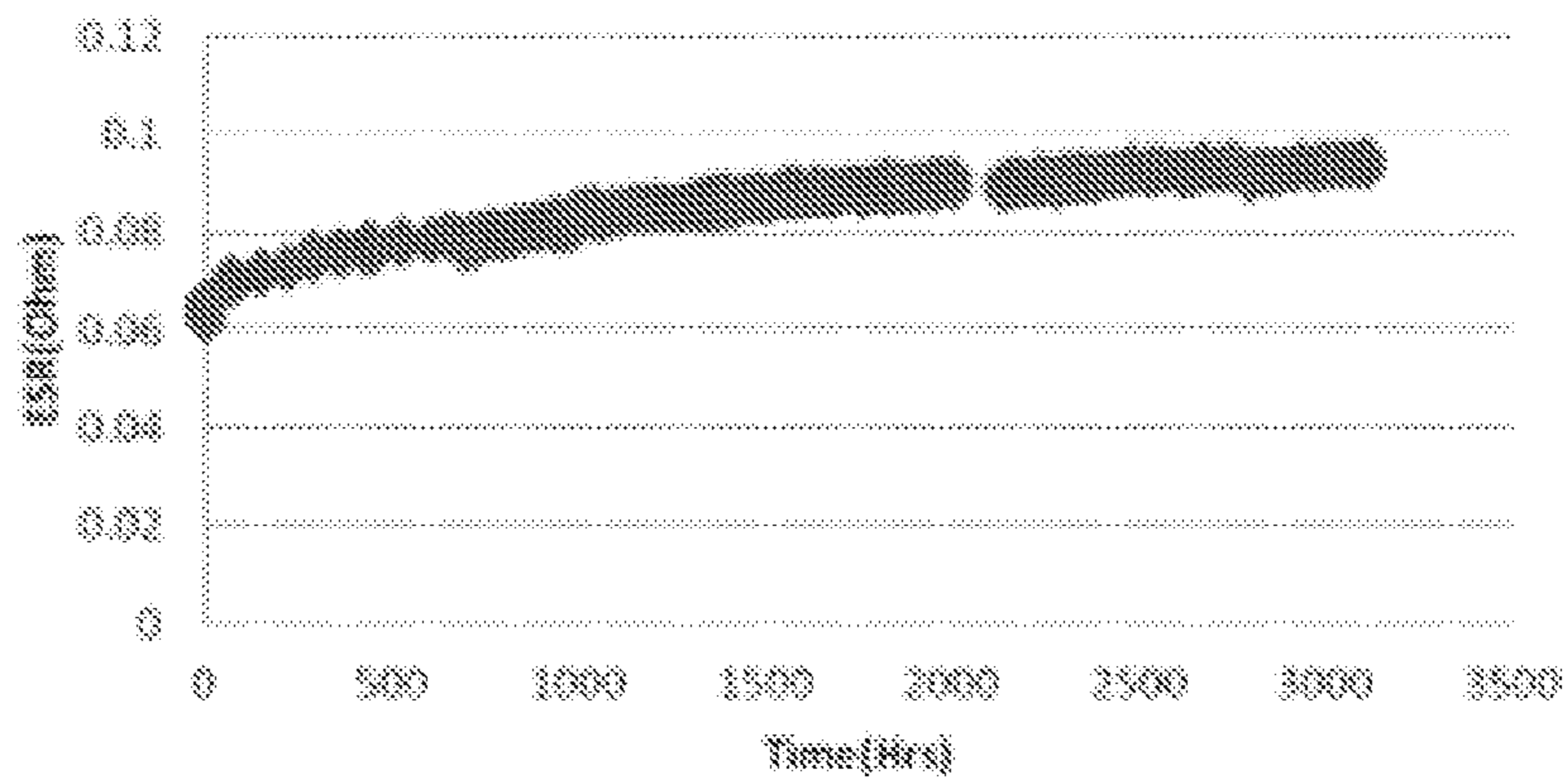

Fig. 48A

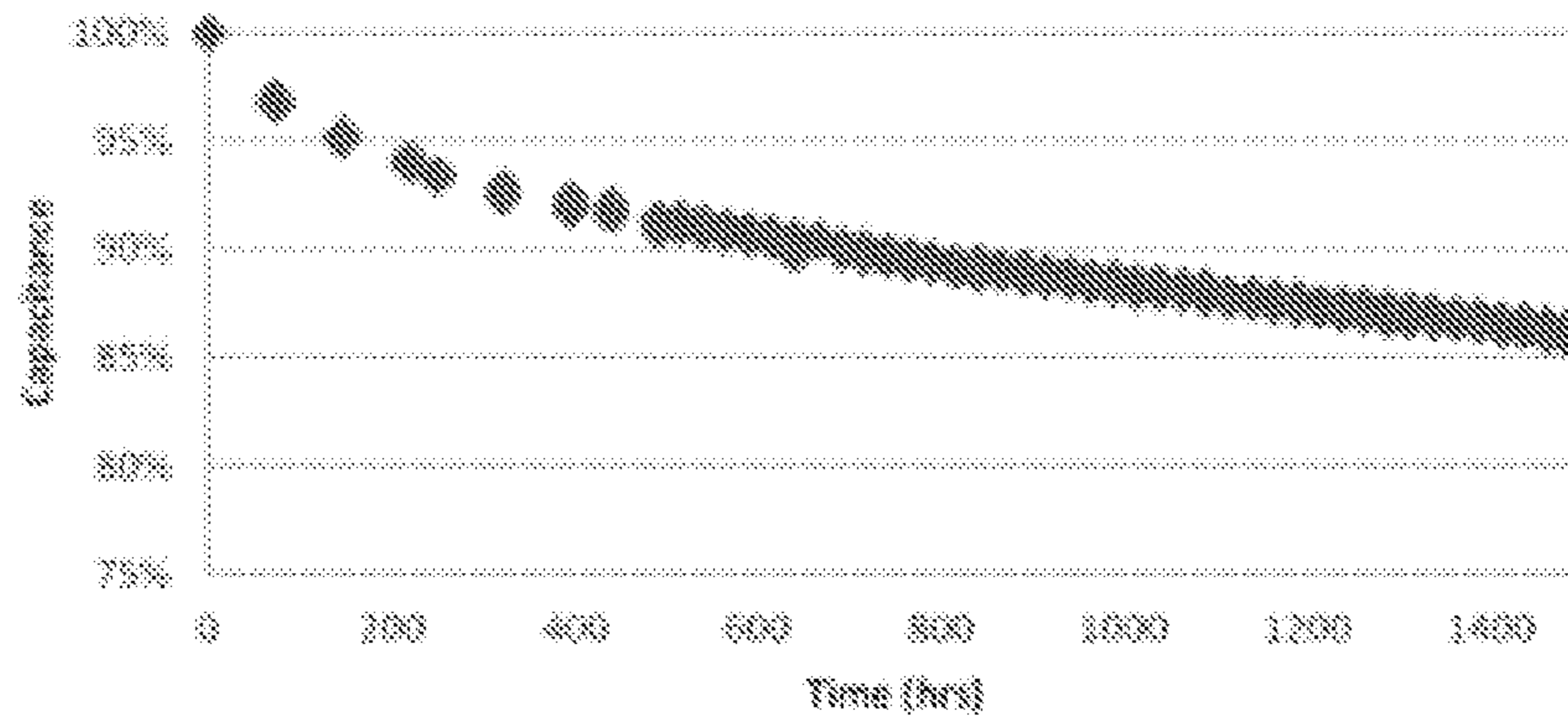

Fig. 48B

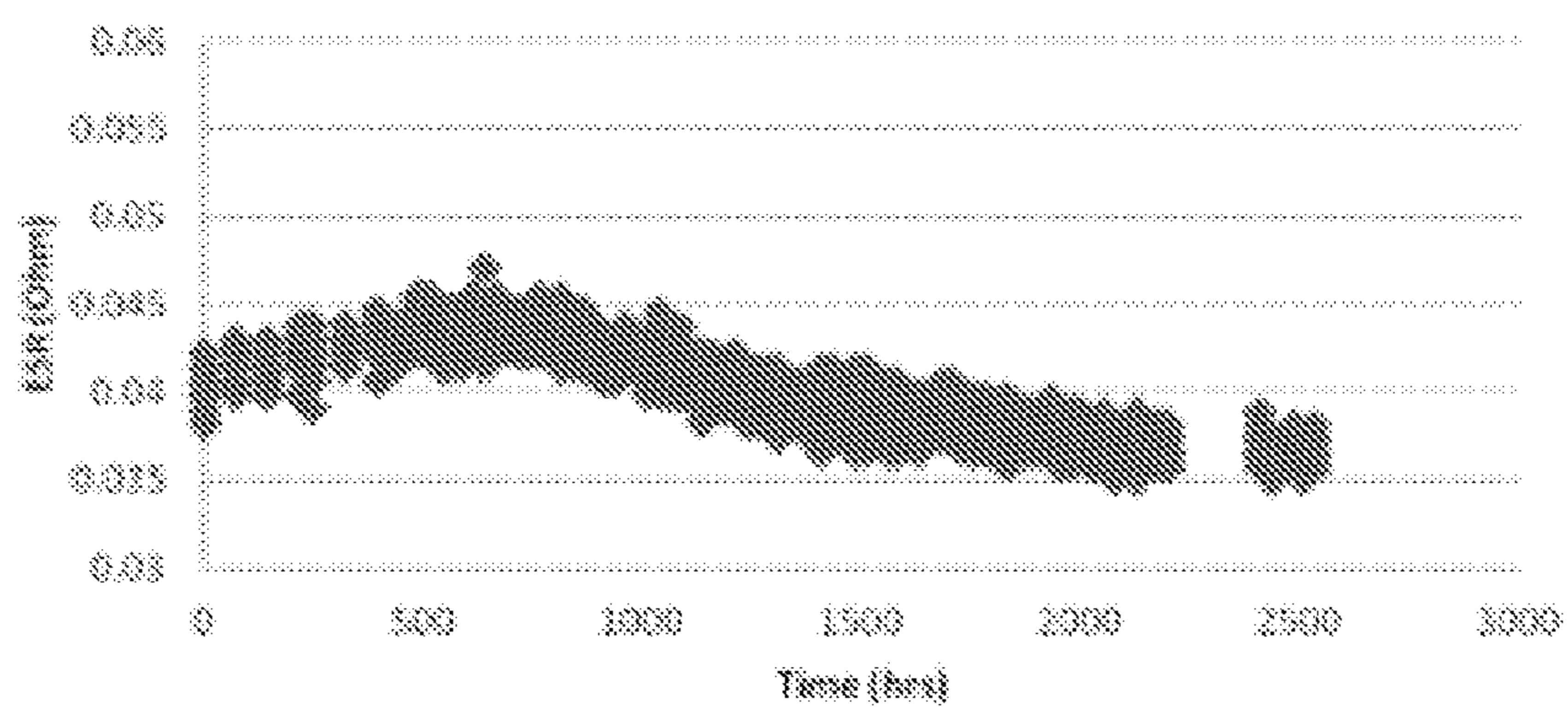
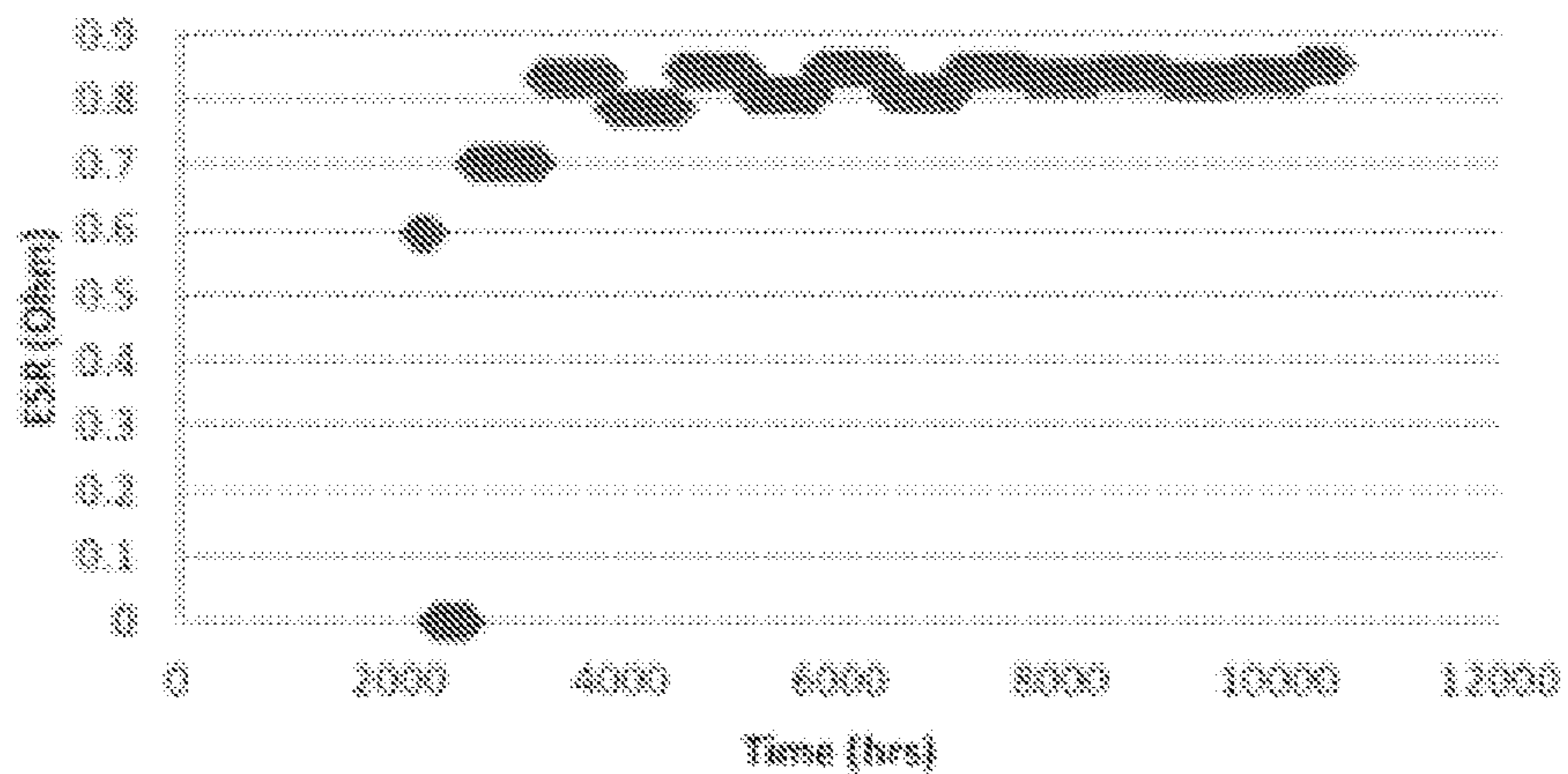

Fig. 49



**ADVANCED ELECTROLYTE SYSTEMS AND
THEIR USE IN ENERGY STORAGE
DEVICES**

CROSS REFERENCE TO RELATED
APPLICATIONS

[0001] This application claims the benefit of priority from U.S. Provisional Patent Application No. 61/602,713, filed Feb. 24, 2012, entitled “Electrolytes for Ultracapacitors,” International Application No. PCT/US2012/045994, filed, Jul. 9, 2012, entitled “High Temperature Energy Storage Device,” U.S. application Ser. No. 13/553,716, filed Jul. 19, 2012, entitled “Power Supply for Downhole Instruments,” and U.S. Provisional Patent Application No. 61/724,775, filed Nov. 9, 2012, entitled “Electrolytes for Ultracapacitors”. The entirety of each of these disclosures is hereby incorporated herein by reference thereto.

BACKGROUND OF THE INVENTION

1. Field of the Invention

[0002] The invention disclosed herein relates to energy storage cells, and in particular to advanced electrolyte systems for use in these energy storage cells, and related techniques for providing an electric double-layer capacitor that is operable at high temperatures.

2. Description of the Related Art

[0003] Energy storage cells are ubiquitous in our society. While most people recognize an energy storage cell simply as a “battery,” other types of cells should also be included within this context. For example, recently, ultracapacitors have garnered much attention as a result of their favorable characteristics. In short, many types of energy storage cells are known and in use today.

[0004] An electric double-layer capacitor, also known as a “supercapacitor,” “supercondenser,” “pseudocapacitor,” “electrochemical double layer capacitor,” or “ultracapacitor,” is a capacitor that exhibits substantially improved performance over common capacitors. One such parameter is energy density. Generally, an ultracapacitor has an energy density that is on the order of thousands of times greater than a high capacity electrolytic capacitor.

[0005] Capacitors are one of the key components in any electronic device and system. Traditional functions include power supply voltage smoothing, supporting the energy source, and filtering. A variety of industries present demanding environments for implementation of electronics and capacitors.

[0006] Consider, for example, that industries such as oil-drilling, aerospace, aviation, military and automotive have some applications that require electrical components to work continuously at high temperatures (for example, at temperatures in excess of eighty degrees Celsius). This heat exposure, along with a variety of factors, work to degrade performance of energy storage systems at elevated temperatures, and lead to premature degradation of the energy storage cell. Durability and safety are key requirements in typical aerospace and defense applications. Applications such as those where engines, turbo fans, and control and sensing electronics are placed near outer shells of a rocket engine. Automotive applications, such as small gearboxes or

embedded alternators/starters, also require durability and long life at elevated temperatures.

[0007] Electronic components used in industrial environments must be physically robust while meeting demands for performance. For designers and producers of ultracapacitors, one of the attendant challenges is obtaining an electrolyte that will function well and reliably at high temperatures, as well as one that will function well and reliably at both high temperatures and low temperatures. Unfortunately, the desirable properties of some electrolytes are not exhibited or sustained at higher temperatures, and even those that have achieved durability at high temperatures have not been able to serve as reliably at lower temperatures. Thus, what are needed are electrolytes for ultracapacitors that perform well in demanding situations. Preferably, the electrolytes provide stable conductivity and low internal resistance as well as stable and high capacitance, and stable and low leakage current over a wide range of temperatures.

SUMMARY OF THE INVENTION

[0008] In one embodiment, an ultracapacitor is disclosed. The ultracapacitor includes an energy storage cell and an advanced electrolyte system (AES) within an hermetically sealed housing, the cell electrically coupled to a positive contact and a negative contact, wherein the ultracapacitor is configured to operate at a temperature within a temperature range between about -40 degrees Celsius to about 210 degrees Celsius.

[0009] In another embodiment, a method for fabricating an ultracapacitor is provided. The method includes the steps of: disposing an energy storage cell comprising energy storage media within a housing; and filling the housing with an advanced electrolyte system (AES), such that an ultracapacitor is fabricated to operate within a temperature range between about -40 degrees Celsius to about 210 degrees Celsius.

[0010] In yet another embodiment, a method of using a high temperature rechargeable energy storage device (HTRES) is provided. The method includes the steps of: obtaining an HTRES comprising an advanced electrolyte system (AES); and cycling the HTRES by alternatively charging and discharging the HTRES at least twice, while maintaining a voltage across the HTRES, such that the HTRES exhibits an initial peak power density between 0.01 W/liter and 150 kW/liter, such that the HTRES is operated at an ambient temperature that is in a temperature range of between about -40 degrees Celsius to about 210 degrees Celsius.

[0011] In yet another embodiment, a method of using an ultracapacitor is provided. The method includes the steps of: obtaining an ultracapacitor as described herein, wherein the ultracapacitor exhibits a volumetric leakage current (mA/cc) that is less than about 10 mA/cc while held at a substantially constant temperature within a range of between about 100 degrees Celsius and about 150 degrees Celsius; and cycling the ultracapacitor by alternatively charging and discharging the ultracapacitor at least twice, while maintaining a voltage across the ultracapacitor, such that the ultracapacitor exhibits an ESR increase less than about 1,000 percent after at least 1 hour of use while held at a substantially constant temperature within a range of between about -40 degrees Celsius to about 210 degrees Celsius.

[0012] In another embodiment, a method of providing a high temperature rechargeable energy storage device to a

user is provided. The method includes the steps of selecting a high temperature rechargeable energy storage device (HTRES) comprising an advanced electrolyte system (AES) that exhibits an initial peak power density between 0.01 Whiter and 100 kW/liter and a durability period of at least 1 hour when exposed to an ambient temperature in a temperature range from about -40 degrees Celsius to about 210 degrees Celsius; and delivering the storage device, such that the HTRES is provided to the user.

[0013] In yet another embodiment, a method of providing a high temperature rechargeable energy storage device to a user is provided. The method includes the steps of obtaining any ultracapacitor as described herein that exhibits a volumetric leakage current (mA/cc) that is less than about 10 mA/cc while held at a substantially constant temperature within a range of between about -40 degrees Celsius and about 210 degrees Celsius; and delivering the storage device, such that the HTRES is provided to the user.

[0014] In yet another embodiment, an advanced electrolyte system (AES) is disclosed. The AES comprises an ionic liquid comprising at least one anion and at least one cation and exhibits a halide content less than 1,000 ppm and a water content less than 100 ppm.

[0015] In yet another embodiment, an advanced electrolyte system (AES) is disclosed. The AES comprises an ionic liquid comprising at least one anion and at least one cation and at least one solvent and exhibits a halide content less than 1,000 ppm and a water content less than 1.000 ppm.

BRIEF DESCRIPTION OF THE DRAWINGS

[0016] The foregoing and other features and advantages of the invention are apparent from the following detailed description taken in conjunction with the accompanying drawings, which should not be considered as limiting:

[0017] FIG. 1 illustrates aspects of an exemplary ultracapacitor;

[0018] FIG. 2 is a block diagram depicting a plurality of carbon nanotubes (CNT) grown onto a substrate;

[0019] FIG. 3 is a block diagram depicting deposition of a current collector onto the CNT of FIG. 3 to provide an electrode element;

[0020] FIG. 4 is a block diagram depicting addition of transfer tape to the electrode element of FIG. 3;

[0021] FIG. 5 is a block diagram depicting the electrode element during a transfer process;

[0022] FIG. 6 is a block diagram depicting the electrode element subsequent to transfer;

[0023] FIG. 7 is a block diagram depicting an exemplary electrode fabricated from a plurality of the electrode elements;

[0024] FIG. 8 depicts embodiments of primary structures for cations that may be included in the exemplary ultracapacitor;

[0025] FIGS. 9 and 10 provide comparative data for the exemplary ultracapacitor making use of raw electrolyte and purified electrolyte, respectively;

[0026] FIG. 11 depicts an embodiment of a housing for an exemplary ultracapacitor;

[0027] FIG. 12 illustrates an embodiment of a storage cell for an exemplary capacitor;

[0028] FIG. 13 depicts a barrier disposed on an interior portion of a body of the housing;

[0029] FIGS. 14A and 14B, collectively referred to herein as FIG. 14, depict aspects of a cap for the housing;

[0030] FIG. 15 depicts assembly of the ultracapacitor according to the teachings herein;

[0031] FIGS. 16A and 16B, collectively referred to herein as FIG. 16, are graphs depicting performance for the ultracapacitor for an embodiment without a barrier and a similar embodiment that includes the barrier, respectively;

[0032] FIG. 17 depicts the barrier disposed about the storage cell as a wrapper;

[0033] FIGS. 18A, 18B and 18C, collectively referred to herein as FIG. 18, depict embodiments of the cap that include multi-layered materials;

[0034] FIG. 19 is a cross-sectional view of an electrode assembly that includes a glass-to-metal seal;

[0035] FIG. 20 is a cross-sectional view of the electrode assembly of FIG. 19 installed in the cap of FIG. 18B;

[0036] FIG. 21 depicts an arrangement of the energy storage cell in assembly;

[0037] FIGS. 22A, 22B and 22C, collectively referred to herein as FIG. 22, depict embodiments of an assembled energy storage cell;

[0038] FIG. 23 depicts incorporation of polymeric insulation into the ultracapacitor;

[0039] FIGS. 24A, 24B and 24C, collectively referred to herein as FIG. 24, depict aspects of a template for another embodiment of the cap for the energy storage;

[0040] FIG. 25 is a perspective view of an electrode assembly that includes hemispherically shaped material;

[0041] FIG. 26 is a perspective view of a cap including the electrode assembly of FIG. 25 installed in the template of FIG. 24;

[0042] FIG. 27 is a cross-sectional view of the cap of FIG. 26;

[0043] FIG. 28 depicts coupling of the electrode assembly with a terminal of a storage cell;

[0044] FIG. 29 is a transparent isometric view of the energy storage cell disposed in a cylindrical housing;

[0045] FIG. 30 is a side view of the storage cell, showing the various layers of one embodiment;

[0046] FIG. 31 is an isometric view of a rolled up storage cell which includes a reference mark for placing a plurality of leads;

[0047] FIG. 32 is an isometric view of the storage cell of FIG. 31 once unrolled;

[0048] FIG. 33 depicts the rolled up storage cell with the plurality of leads included;

[0049] FIG. 34 depicts a Z-fold imparted into aligned leads (i.e., a terminal) coupled to the storage cell;

[0050] FIGS. 35-38 are graphs depicting performance of exemplary ultracapacitors; and

[0051] FIGS. 39-43 are graphs depicting performance of exemplary ultracapacitors at 210 degrees Celsius.

[0052] FIGS. 44A and 44B are capacitance and ESR graphs, respectively, depicting performance for an ultracapacitor with the novel electrolyte entity: 1-butyl-1-methylpiperidinium bis(trifluoromethylsulfonyl)imide at 150 degrees Celsius and 1.5V.

[0053] FIGS. 45A and 45B are capacitance and ESR graphs, respectively, depicting performance for an ultracapacitor with the novel electrolyte entity, trihexyltetradecylphosphonium bis(trifluoromethylsulfonyl)imide at 150 degrees Celsius and 1.5V.

[0054] FIGS. 46A and 46B are capacitance and ESR graphs, respectively, depicting performance for an ultraca-

pacitor with the novel electrolyte entity, butyltrimethylammonium bis(trifluoromethylsulfonyl)imide at 150 degrees Celsius and 1.5V.

[0055] FIGS. 47A and 47B are capacitance and ESR graphs, respectively, depicting performance for an ultracapacitor with an ionic liquid selected from the ionic liquids used in preparing the enhanced electrolyte combinations, at 125 degrees Celsius and 1.5V.

[0056] FIGS. 48A and 48B are capacitance and ESR graphs, respectively, depicting performance for an ultracapacitor with a 37.5% organic solvent-ionic liquid (same as in FIG. 47) v/v, at 125 degrees Celsius and 1.5V

[0057] FIG. 49 is an ESR graph depicting performance for an ultracapacitor with a 37.5% organic solvent-ionic liquid (same as in FIG. 47) v/v, at -40 degrees Celsius and 1.5V.

DETAILED DESCRIPTION OF THE INVENTION

[0058] In the present application a variety of variables are described, including but not limited to components (e.g. electrode materials, electrolytes, etc.), conditions (e.g., temperature, freedom from various impurities at various levels), and performance characteristics (e.g., post-cycling capacity as compared with initial capacity, low leakage current, etc.). It is to be understood that any combination of any of these variables can define an embodiment of the invention. For example, a combination of a particular electrode material, with a particular electrolyte, under a particular temperature range and with impurity less than a particular amount, operating with post-cycling capacity and leakage current of particular values, where those variables are included as possibilities but the specific combination might not be expressly stated, is an embodiment of the invention. Other combinations of articles, components, conditions, and/or methods can also be specifically selected from among variables listed herein to define other embodiments, as would be apparent to those of ordinary skill in the art.

[0059] The present invention, including advanced electrolyte systems and uses thereof will be described with reference to the following definitions that, for convenience, are set forth below. Unless otherwise specified, the below terms used herein are defined as follows:

I. Definitions

[0060] When introducing elements of the present invention or the embodiment(s) thereof, the articles “a,” “an,” and “the” are intended to mean that there are one or more of the elements. Similarly, the adjective “another,” when used to introduce an element, is intended to mean one or more elements. The terms “including,” “has” and “having” are intended to be inclusive such that there may be additional elements other than the listed elements.

[0061] The terms “alkenyl” and “alkynyl” are recognized in the art and refer to unsaturated aliphatic groups analogous in length and possible substitution to the alkyls described below, but that contain at least one double or triple bond respectively.

[0062] The term “alkyl” is recognized in the art and may include saturated aliphatic groups, including straight-chain alkyl groups, branched-chain alkyl groups, cycloalkyl (alicyclic) groups, alkyl substituted cycloalkyl groups, and cycloalkyl substituted alkyl groups. In certain embodiments, a straight chain or branched chain alkyl has about 20 or

fewer carbon atoms in its backbone (e.g., C₁-C₂₀ for straight chain, C₁-C₂₀ for branched chain). Likewise, cycloalkyls have from about 3 to about 10 carbon atoms in their ring structure, and alternatively about 5, 6 or 7 carbons in the ring structure. Examples of alkyl groups include, but are not limited to, methyl, ethyl, propyl, butyl, pentyl, hexyl, ethyl hexyl, cyclopropyl, cyclobutyl, cyclopentyl, cyclohexyl and the like.

[0063] As used herein, the terms “clad,” “cladding” and the like refer to the bonding together of dissimilar metals. Cladding is often achieved by extruding two metals through a die as well as pressing or rolling sheets together under high pressure. Other processes, such as laser cladding, may be used. A result is a sheet of material composed of multiple layers, where the multiple layers of material are bonded together such that the material may be worked with as a single sheet (e.g., formed as a single sheet of homogeneous material would be formed).

[0064] As a matter of convention, it may be considered that a “contaminant” may be defined as any unwanted material that may negatively affect performance of the ultracapacitor 10 if introduced. Also note, that generally herein, contaminants may be assessed as a concentration, such as in parts-per-million (ppm). The concentration may be taken as by weight, volume, sample weight, or in any other manner as determined appropriate.

[0065] The term “cyano” is given its ordinary meaning in the art and refers to the group, CN. The term “sulfate” is given its ordinary meaning in the art and refers to the group, SO₂. The term “sulfonate” is given its ordinary meaning in the art and refers to the group, SO₃X, where X may be an electron pair, hydrogen, alkyl or cycloalkyl. The term “carbonyl” is recognized in the art and refers to the group, C=O.

[0066] In general, the term “electrode” refers to an electrical conductor that is used to make contact to another material which is often non-metallic, in a device that may be incorporated into an electrical circuit. Generally, the term “electrode,” as used herein, is with reference to the current collector 2 and the additional components as may accompany the current collector 2 (such as the energy storage media 1) to provide for desired functionality (for example, the energy storage media 1 which is mated to the current collector 2 to provide for energy storage and energy transmission).

[0067] “Energy density” is one half times the square of a peak device voltage times a device capacitance divided by a mass or volume of said device

[0068] As discussed herein, “hermetic” refers to a seal whose quality (i.e., leak rate) is defined in units of “atm-cc/second,” which means one cubic centimeter of gas (e.g., He) per second at ambient atmospheric pressure and temperature. This is equivalent to an expression in units of “standard He-cc/sec.” Further, it is recognized that 1 atm-cc/sec is equal to 1.01325 mbar-liter/sec.

[0069] The terms “heteroalkenyl” and “heteroalkynyl” are recognized in the art and refer to alkenyl and alkynyl alkyl groups as described herein in which one or more atoms is a heteroatom (e.g., oxygen, nitrogen, sulfur, and the like).

[0070] The term “heteroalkyl” is recognized in the art and refers to alkyl groups as described herein in which one or more atoms is a heteroatom (e.g., oxygen, nitrogen, sulfur, and the like). For example, alkoxy group (e.g., —OR) is a heteroalkyl group.

[0071] As a matter of convention, the terms “internal resistance” and “effective series resistance” and “ESR”, terms that are known in the art to indicate a resistive aspect of a device, are used interchangeably herein.

[0072] As a matter of convention, the term “leakage current” generally refers to current drawn by the capacitor which is measured after a given period of time. This measurement is performed when the capacitor terminals are held at a substantially fixed potential difference (terminal voltage). When assessing leakage current, a typical period of time is seventy two (72) hours, although different periods may be used. It is noted that leakage current for prior art capacitors generally increases with increasing volume and surface area of the energy storage media and the attendant increase in the inner surface area of the housing. In general, an increasing leakage current is considered to be indicative of progressively increasing reaction rates within the ultracapacitor 10. Performance requirements for leakage current are generally defined by the environmental conditions prevalent in a particular application. For example, with regard to an ultracapacitor 10 having a volume of 20 mL, a practical limit on leakage current may fall below 200 mA.

[0073] A “lifetime” for the capacitor is also generally defined by a particular application and is typically indicated by a certain percentage increase in leakage current or degradation of another parameter such as capacitance or internal resistance (as appropriate or determinative for the given application). For instance, in one embodiment, the lifetime of a capacitor in an automotive application may be defined as the time at which the leakage current increases to 200% of its initial (beginning of life or “BOL”) value. In another example, the lifetime of a capacitor in an oil and gas application may be defined as the time at which any of the following occurs: the capacitance falls to 50% of its BOL value, the internal resistance increases to 200% of its BOL value, the leakage increases to 200% of its BOL value. As a matter of convention, the terms “durability” and “reliability” of a device when used herein generally relate to a lifetime of said device as defined above.

[0074] An “operating temperature range” of a device generally relates to a range of temperatures within which certain levels of performance are maintained and is generally determined for a given application. For instance, in one embodiment, the operating temperature range for an oil and gas application may be defined as the temperature range in which the resistance of a device is less than about 1,000% of the resistance of said device at 30 degrees Celsius, and the capacitance is more than about 10% of the capacitance at 30 degrees Celsius.

[0075] In some instances, an operating temperature range specification provides for a lower bound of useful temperatures whereas a lifetime specification provides for an upper bound of useful temperatures.

[0076] “Peak power density” is one fourth times the square of a peak device voltage divided by an effective series resistance of said device divided by a mass or volume of said device.

[0077] As referred to herein, a “volumetric leakage current” of the ultracapacitor 10 generally refers to leakage current divided by a volume of the ultracapacitor 10, and may be expressed, for example in units of mA/cc. Similarly, a “volumetric capacitance” of the ultracapacitor 10 generally refers to capacitance of the ultracapacitor 10 divided by the volume of the ultracapacitor 10, and may be expressed, for

example in units of F/cc. Additionally, “volumetric ESR” of the ultracapacitor 10 generally refers to ESR of the ultracapacitor 10 multiplied by the volume of the ultracapacitor 10, and may be expressed, for example in units of Ohms·cc.

[0078] As a matter of convention, it should be considered that the term “may” as used herein is to be construed as optional; “includes” is to be construed as not excluding other options (i.e., steps, materials, components, compositions, etc); “should” does not imply a requirement, rather merely an occasional or situational preference. Other similar terminology is likewise used in a generally conventional manner.

[0079] As discussed herein, terms such as “adapting,” “configuring,” “constructing” and the like may be considered to involve application of any of the techniques disclosed herein, as well as other analogous techniques (as may be presently known or later devised) to provide an intended result.

II. Capacitors of the Invention

[0080] Disclosed herein are capacitors that provide users with improved performance in a wide range of temperatures. For example, the capacitor of the present invention comprising advanced electrolyte systems described herein may be operable at temperatures ranging from about as low as minus 40 degrees Celsius to as high as about 210 degrees Celsius.

[0081] In general, the capacitor of the present invention includes energy storage media that is adapted for providing a combination of high reliability, wide operating temperature range, high power density and high energy density when compared to prior art devices. The capacitor includes components that are configured to ensure operation over the temperature range, and includes electrolytes 6 that are selected solely from the advanced electrolyte systems described herein. The combination of construction, energy storage media and advanced electrolyte systems provide the robust capacitors of the present invention that afford operation under extreme conditions with enhanced properties over existing capacitors, and with greater performance and durability.

[0082] Accordingly, the present invention provides an ultracapacitor comprising: an energy storage cell and an advanced electrolyte system (AES) within an hermetically sealed housing, the cell electrically coupled to a positive contact and a negative contact, wherein the ultracapacitor is configured to operate at a temperature within a temperature range (“operating temperature”) between about -40 degrees Celsius to about 210 degrees Celsius; about -35 degrees Celsius to about 210 degrees Celsius; about -40 degrees Celsius to about 205 degrees Celsius; about -30 degrees Celsius to about 210 degrees Celsius; about -40 degrees Celsius to about 200 degrees Celsius; about -25 degrees Celsius to about 210 degrees Celsius; about -40 degrees Celsius to about 195 degrees Celsius; about -20 degrees Celsius to about 210 degrees Celsius; about -40 degrees Celsius to about 190 degrees Celsius; about -15 degrees Celsius to about 210 degrees Celsius; about -40 degrees Celsius to about 185 degrees Celsius; about -10 degrees Celsius to about 210 degrees Celsius; about -40 degrees Celsius to about 180 degrees Celsius; about -5 degrees Celsius to about 210 degrees Celsius; about -40 degrees Celsius to about 175 degrees Celsius; about 0 degrees Celsius to about 210 degrees Celsius; about -40 degrees Celsius to about 170 degrees Celsius; about 5 degrees

Celsius to about 210 degrees Celsius; about -40 degrees Celsius to about 165 degrees Celsius; about 10 degrees Celsius to about 210 degrees Celsius; about -40 degrees Celsius to about 160 degrees Celsius; about 15 degrees Celsius to about 210 degrees Celsius; about -40 degrees Celsius to about 155 degrees Celsius; about 20 degrees Celsius to about 210 degrees Celsius; about -40 degrees Celsius to about 150 degrees Celsius.

[0083] In one particular embodiment, the AES comprises a novel electrolyte entity (NEE), e.g., wherein the NEE is adapted for use in high temperature ultracapacitors. In certain embodiments, the ultracapacitor is configured to operate at a temperature within a temperature range between about 80 degrees Celsius to about 210 degrees Celsius, e.g., a temperature range between about 80 degrees Celsius to about 150 degrees Celsius.

[0084] In one particular embodiment, the AES comprises a highly purified electrolyte, e.g., wherein the highly purified electrolyte is adapted for use in high temperature ultracapacitors. In certain embodiments, the ultracapacitor is configured to operate at a temperature within a temperature range between about 80 degrees Celsius to about 210 degrees Celsius.

[0085] In one particular embodiment, the AES comprises AES comprises an enhanced electrolyte combination, e.g., wherein the enhanced electrolyte combination is adapted for use in both high and low temperature ultracapacitors. In certain embodiments, the ultracapacitor is configured to operate at a temperature within a temperature range between about -40 degrees Celsius to about 150 degrees Celsius.

[0086] As such, and as noted above, the advantages over the existing electrolytes of known energy storage devices are selected from one or more of the following improvements: decreased total resistance, increased long-term stability of resistance, increased total capacitance, increased long-term stability of capacitance, increased energy density, increased voltage stability, reduced vapor pressure, wider temperature range performance for an individual capacitor, increased temperature durability for an individual capacitor, increased ease of manufacturability, and improved cost effectiveness.

[0087] In certain embodiments of the ultracapacitor, the energy storage cell comprises a positive electrode and a negative electrode.

[0088] In certain embodiments of the ultracapacitor, at least one of the electrodes comprises a carbonaceous energy storage media, e.g., wherein the carbonaceous energy storage media comprises carbon nanotubes. In particular embodiments, the carbonaceous energy storage media may comprise at least one of activated carbon, carbon fibers, rayon, graphene, aerogel, carbon cloth, and carbon nanotubes.

[0089] In certain embodiments of the ultracapacitor, each electrode comprises a current collector.

[0090] In certain embodiments of the ultracapacitor, the AES is purified to reduce impurity content. In certain embodiments of the ultracapacitor, the content of halide ions in the electrolyte is less than about 1,000 parts per million, e.g., less than about 500 parts per million, e.g., less than about 100 parts per million, e.g., less than about 50 parts per million. In a particular embodiment, the halide ion in the electrolyte is selected from one or more of the halide ions selected from the group consisting of chloride, bromide, fluoride and iodide. In particular embodiments, the total concentration of impurities in the electrolyte is less than

about 1,000 parts per million. In certain embodiments, the impurities are selected from one or more of the group consisting of bromoethane, chloroethane, 1-bromobutane, 1-chlorobutane, 1-methylimidazole, ethyl acetate and methylene chloride.

[0091] In certain embodiments of the ultracapacitor, the total concentration of metallic species in the electrolyte is less than about 1,000 parts per million. In a particular embodiment, the metallic species is selected from one or more metals selected from the group consisting of Cd, Co, Cr, Cu, Fe, K, Li, Mo, Na, Ni, Pb, and Zn. In another particular embodiment, the metallic species is selected from one or more alloys of metals selected from the group consisting of Cd, Co, Cr, Cu, Fe, K, Li, Mo, Na, Ni, Pb, and Zn. In yet another particular embodiment, the metallic species is selected from one or more oxides of metals selected from the group consisting of Cd, Co, Cr, Cu, Fe, K, Li, Mo, Na, Ni, Pb, and Zn.

[0092] In certain embodiments of the ultracapacitor, the total water content in the electrolyte is less than about 500 parts per million, e.g., less than about 100 parts per million, e.g., less than about 50 parts per million, e.g., about 20 parts per million.

[0093] In certain embodiments of the ultracapacitor, the housing comprises a barrier disposed over a substantial portion of interior surfaces thereof. In particular embodiments, the barrier comprises at least one of polytetrafluoroethylene (PTFE), perfluoroalkoxy (PFA), fluorinated ethylene propylene (FEP), ethylene tetrafluoroethylene (ETFE). In particular embodiments, the barrier comprises a ceramic material. The barrier may also comprise a material that exhibits corrosion resistance, a desired dielectric property, and a low electrochemical reactivity. In a specific embodiment of the barrier, the barrier comprises multiple layers of materials.

[0094] In certain embodiments of the ultracapacitor, the housing comprises a multilayer material, e.g., wherein the multilayer material comprises a first material clad onto a second material. In a particular embodiment, the multilayer material comprises at least one of steel, tantalum and aluminum.

[0095] In certain embodiments of the ultracapacitor, the housing comprises at least one hemispheric seal.

[0096] In certain embodiments of the ultracapacitor, the housing comprises at least one glass-to-metal seal, e.g., wherein a pin of the glass-to-metal seal provides one of the contacts. In a particular embodiment, the glass-to-metal seal comprises a feed-through that is comprised of a material selected from the group consisting of an iron-nickel-cobalt alloy, a nickel iron alloy, tantalum, molybdenum, niobium, tungsten, and a form of stainless and titanium. In another particular embodiment, the glass-to-metal seal comprises a body that is comprised of at least one material selected from the group consisting of nickel, molybdenum, chromium, cobalt, iron, copper, manganese, titanium, zirconium, aluminum, carbon, and tungsten and an alloy thereof.

[0097] In certain embodiments of the ultracapacitor, the energy storage cell comprises a separator to provide electrical separation between a positive electrode and a negative electrode, e.g., wherein the separator comprises a material selected from the group consisting of polyamide, polytetrafluoroethylene (PTFE), polyether ether ketone (PEEK), aluminum oxide (Al₂O₃), fiberglass, fiberglass reinforced plastic, or any combination thereof. In a particular embodiment,

the separator is substantially free of moisture. In another particular embodiment, the separator is substantially hydrophobic.

[0098] In certain embodiments of the ultracapacitor, the hermetic seal exhibits a leak rate that is no greater than about 5.0×10^{-6} atm-cc/sec, e.g., no greater than about 5.0×10^{-7} atm-cc/sec, e.g., no greater than about 5.0×10^{-8} atm-cc/sec, e.g., no greater than about 5.0×10^{-9} atm-cc/sec, e.g., no greater than about 5.0×10^{-10} atm-cc/sec.

[0099] In certain embodiments of the ultracapacitor, at least one contact is configured for mating with another contact of another ultracapacitor.

[0100] In certain embodiments of the ultracapacitor, the storage cell comprises a wrapper disposed over an exterior thereof, e.g., wherein the wrapper comprises one of PTFE and polyimide.

[0101] In certain embodiments of the ultracapacitor, a volumetric leakage current is less than about 10 Amperes per Liter within the temperature range.

[0102] In certain embodiments of the ultracapacitor, a volumetric leakage current is less than about 10 Amperes per Liter over a specified voltage range between about 0 Volts and about 4 Volts, e.g. between about 0 Volts and about 3 Volts, e.g. between about 0 Volts and about 2 Volts, e.g. between about 0 Volts and about 1 Volt. In certain embodiments of the ultracapacitor, the level of moisture within the housing is less than about 1,000 parts per million (ppm), e.g., less than about 500 parts per million (ppm), e.g., less than about 350 parts per million (ppm).

[0103] In certain embodiments of the ultracapacitor, the moisture content in an electrode of the ultracapacitor that is less than about 1,000 ppm, e.g., less than about 500 ppm, e.g., less than about 350 parts per million (ppm).

[0104] In certain embodiments of the ultracapacitor, the moisture content in a separator of the ultracapacitor that is less than about 1,000 ppm, e.g., less than about 500 ppm, e.g., less than about 160 parts per million (ppm).

[0105] In certain embodiments of the ultracapacitor, the chloride content is less than about 300 ppm for one of the components selected from the group consisting of an electrode, electrolyte and a separator.

[0106] In certain embodiments of the ultracapacitor, the volumetric leakage current (mA/cc) of the ultracapacitor is less than about 10 mA/cc while held at the substantially constant temperature, e.g., less than about 1 mA/cc while held at the substantially constant temperature. In a particular embodiment,

[0107] In certain embodiments of the ultracapacitor, the volumetric leakage current of the ultracapacitor is greater than about 0.0001 mA/cc while held at the substantially constant temperature.

[0108] In certain embodiments of the ultracapacitor, volumetric capacitance of the ultracapacitor is between about 6 F/cc and about 1 mF/cc; between about 10 F/cc and about 5 F/cc; or between about 50 F/cc and about 8 F/cc.

[0109] In certain embodiments of the ultracapacitor, the volumetric ESR of the ultracapacitor is between about 20 mOhms-cc and 200 mOhms-cc; between about 150 mOhms-cc and 2 Ohms-cc; between about 1.5 Ohms-cc and 200 Ohms-cc; or between about 150 Ohms-cc and 2000 Ohms-cc.

[0110] In certain embodiments of the ultracapacitor, the ultracapacitor exhibits a capacitance decrease less than about 90 percent while held at a substantially constant

voltage and operating temperature. In a particular embodiment, the ultracapacitor exhibits a capacitance decrease less than about 90 percent while held at a substantially constant voltage and operating temperature for at least 1 hour, e.g. for at least 10 hours, e.g. for at least 50 hours, e.g. for at least 100 hours, e.g. for at least 200 hours, e.g. for at least 300 hours, e.g. for at least 400 hours, e.g. for at least 500 hours, e.g. for at least 1,000 hours.

[0111] In certain embodiments of the ultracapacitor, the ultracapacitor exhibits an ESR increase less than about 1,000 percent while held at a substantially constant voltage and operating temperature for at least 1 hour, e.g. for at least 10 hours, e.g. for at least 50 hours, e.g. for at least 100 hours, e.g. for at least 200 hours, e.g. for at least 300 hours, e.g. for at least 400 hours, e.g. for at least 500 hours, e.g. for at least 1,000 hours.

[0112] For example, as shown in FIG. 1, an exemplary embodiment of a capacitor is shown. In this case, the capacitor is an “ultracapacitor 10.” The exemplary ultracapacitor 10 is an electric double-layer capacitor (EDLC). The ultracapacitor 10 may be embodied in several different form factors (i.e., exhibit a certain appearance). Examples of potentially useful form factors include a cylindrical cell, an annular or ring-shaped cell, a flat prismatic cell or a stack of flat prismatic cells comprising a box-like cell, and a flat prismatic cell that is shaped to accommodate a particular geometry such as a curved space. A cylindrical form factor may be most useful in conjunction with a cylindrical system or a system mounted in a cylindrical form factor or having a cylindrical cavity. An annular or ring-shaped form factor may be most useful in conjunction with a system that is ring-shaped or mounted in a ring-shaped form factor or having a ring-shaped cavity. A flat prismatic form factor may be most useful in conjunction with a system that is rectangularly-shaped, or mounted in a rectangularly-shaped form factor or having a rectangularly-shaped cavity.

[0113] While generally disclosed herein in terms of a “jelly roll” application (i.e., a storage cell 12 that is configured for a cylindrically shaped housing 7), the rolled storage cell 23 may take any form desired. For example, as opposed to rolling the storage cell 12, folding of the storage cell 12 may be performed to provide for the rolled storage cell 23. Other types of assembly may be used. As one example, the storage cell 12 may be a flat cell, referred to as a coin type, pouch type, or prismatic type of cell. Accordingly, rolling is merely one option for assembly of the rolled storage cell 23. Therefore, although discussed herein in terms of being a “rolled storage cell 23”, this is not limiting. It may be considered that the term “rolled storage cell 23” generally includes any appropriate form of packaging or packing the storage cell 12 to fit well within a given design of the housing 7.

[0114] Various forms of the ultracapacitor 10 may be joined together. The various forms may be joined using known techniques, such as welding contacts together, by use of at least one mechanical connector, by placing contacts in electrical contact with each other and the like. A plurality of the ultracapacitors 10 may be electrically connected in at least one of a parallel and a series fashion.

[0115] For the purposes of this invention, an ultracapacitor 10 may have a volume in the range from about 0.05 cc to about 7.5 liters.

[0116] A variety of environments may exist where the ultracapacitor 10 is particularly useful. For example, in

automotive applications, ambient temperatures of 105 degrees Celsius may be realized (where a practical lifetime of the capacitor will range from about 1 year to 20 years). In some downhole applications, such as for geothermal well drilling, ambient temperatures of 300 degrees Celsius or more may be reached (where a practical lifetime of the capacitor will range from about 1 hour to about 10,000 hours).

[0117] The components of the ultracapacitors of the present invention will now be discussed, in turn.

[0118] A. Advanced Electrolyte Systems of the Invention

[0119] The advanced electrolyte systems of the present invention provide the electrolyte component of the ultracapacitors of the present invention, and are noted as “electrolyte 6” in FIG. 1. The electrolyte 6 fills void spaces in and between the electrodes 3 and the separator 5. In general, the advanced electrolyte systems of the invention comprise unique electrolytes, purified enhanced electrolytes, or combinations thereof, wherein the electrolyte 6 is a substance, e.g., comprised of one or more salts or ionic liquids, which disassociate into electrically charged ions (i.e., positively charged cations and negatively charged anions) and may include a solvent. In the advanced electrolyte systems of the present invention, such electrolyte components are selected based on the enhancement of certain performance and durability characteristics, and may be combined with one or more solvents, which dissolve the substance to generate compositions with novel and useful electrochemical stability and performance.

[0120] The advanced electrolyte systems of the present invention afford unique and distinct advantages to the ultracapacitors of the present invention over existing energy storage devices (e.g., energy storage devices containing electrolytes not disclosed herein, or energy storage devices containing electrolytes having insufficient purity). These advantages include improvements in both performance and durability characteristics, such as one or more of the following: decreased total resistance, increased long-term stability of resistance (e.g., reduction in increased resistance of material over time at a given temperature), increased total capacitance, increased long-term stability of capacitance (e.g. reduction in decreased capacitance of a capacitor over time at a given temperature), increased energy density (e.g. by supporting a higher voltage and/or by leading to a higher capacitance), increased voltage stability, reduced vapor pressure, wider temperature range performance for an individual capacitor (e.g. without a significant drop in capacitance and/or increase in ESR when transitioning between two temperatures, e.g. without more than a 90% decrease in capacitance and/or a 1000% increase in ESR when transitioning from about +30° C. to about -40° C.), increased temperature durability for an individual capacitor (e.g., less than a 50% decrease in capacitance at a given temperature after a given time and/or less than a 100% increase in ESR at a given temperature after a given time, and/or less than 10 A/L of leakage current at a given temperature after a given time, e.g., less than a 40% decrease in capacitance and/or a 75% increase in ESR, and/or less than 5 A/L of leakage current, e.g., less than a 30% decrease in capacitance and/or a 50% increase in ESR, and/or less than 1 A/L of leakage current); increased ease of manufacturability (e.g. by having a reduced vapor pressure, and therefore better yield and/or more efficient methods of filling a capacitor with electrolyte), and improved cost effectiveness (e.g. by filling void

space with material that is less costly than another material). For clarity, performance characteristics relate to the properties directed to utility of the device at a given point of use suitable for comparison among materials at a similar given point of use, while durability characteristics relate to properties directed to ability to maintain such properties over time. The performance and durability examples above should serve to provide context for what are considered “significant changes in performance or durability” herein.

[0121] For clarity, and in general, reference to “electrolyte 6” as used herein for inclusion in the energy storage devices of the present invention refers to the advanced electrolyte systems of the present invention.

[0122] The properties of the AES, or Electrolyte 6, may be the result of improvements in properties selected from increases in capacitance, reductions in equivalent-series-resistance (ESR), high thermal stability, a low glass transition temperature (Tg), an improved viscosity, a particular rheopectic or thixotropic property (e.g., one that is dependent upon temperature), as well as high conductivity and exhibited good electric performance over a wide range of temperatures. As examples, the electrolyte 6 may have a high degree of fluidicity, or, in contrast, be substantially solid, such that separation of electrodes 3 is assured.

[0123] The advanced electrolyte systems of the present invention include, novel electrolytes described herein for use in high temperature ultracapacitors, highly purified electrolytes for use in high temperature ultracapacitors, and enhanced electrolyte combinations suitable for use in temperature ranges from -40 degrees Celsius to 210 degrees Celsius, without a significant drop in performance or durability across all temperatures.

[0124] Although the disclosure presented herein shall focus on the applicability of the advanced electrolyte systems described herein to the ultracapacitors, these advanced electrolyte system are applicable to any energy storage device.

[0125] i. Novel Electrolyte Entities (NEE)

[0126] The advanced electrolyte systems (AES) of the present invention comprise, in one embodiment, certain novel electrolytes for use in high temperature ultracapacitors. In this respect, it has been found that maintaining purity and low moisture relates to a degree of performance of the energy storage 10; and that the use of electrolytes that contain hydrophobic materials and which have been found to demonstrate greater purity and lower moisture content are advantageous for obtaining improved performance. These electrolytes exhibit good performance characteristics in a temperature range of about 80 degrees Celsius to about 210 degrees Celsius, e.g., about 80 degrees Celsius to about 200 degrees Celsius, e.g., about 80 degrees Celsius to about 190 degrees Celsius e.g., about 80 degrees Celsius to about 180 degrees Celsius e.g., about 80 degrees Celsius to about 170 degrees Celsius e.g., about 80 degrees Celsius to about 160 degrees Celsius e.g., about 80 degrees Celsius to about 150 degrees Celsius e.g., about 85 degrees Celsius to about 145 degrees Celsius e.g., about 90 degrees Celsius to about 140 degrees Celsius e.g., about 95 degrees Celsius to about 135 degrees Celsius e.g., about 100 degrees Celsius to about 130 degrees Celsius e.g., about 105 degrees Celsius to about 125 degrees Celsius e.g., about 110 degrees Celsius to about 120 degrees Celsius.

[0127] Accordingly, novel electrolyte entities useful as the advanced electrolyte system (AES) include species compris-

ing a cation (e.g., cations shown in FIG. 8 and described herein) and an anion, or combinations of such species. In some embodiments, the species comprises a nitrogen-containing, oxygen-containing, phosphorus-containing, and/or sulfur-containing cation, including heteroaryl and heterocyclic cations. In one set of embodiments, the advanced electrolyte system (AES) include species comprising a cation selected from the group consisting of ammonium, imidazolium, oxazolium, phosphonium, piperidinium, pyrazinium, pyrazolium, pyridazinium, pyridinium, pyrimidinium, sulfonium, thiazolium, triazolium, guanidium, isoquinolinium, benzotriazolium, and viologen-type cations, any of which may be substituted with substituents as described herein. In one embodiment, the novel electrolyte entities useful for the advanced electrolyte system (AES) of the present invention include any combination of cations presented in FIG. 8, selected from the group consisting of phosphonium, piperidinium, and ammonium, wherein the various branch groups R_x (e.g., $R_1, R_2, R_3, \dots R_x$) may be selected from the group consisting of alkyl, heteroalkyl, alkenyl, heteroalkenyl, alkynyl, heteroalkynyl, halo, amino, nitro, cyano, hydroxyl, sulfate, sulfonate, and carbonyl, any of which is optionally substituted, and wherein at least two R_x are not H (i.e., such that the selection and orientation of the R groups produce the cationic species shown in FIG. 8); and the anion selected from the group consisting of tetrafluoroborate, bis(trifluoromethylsulfonyl)imide, tetracyanoborate, and trifluoromethanesulfonate.

[0128] For example, given the combinations of cations and anions above, in a particular embodiment, the AES may be selected from the group consisting of trihexyltetradecylphosphonium bis(trifluoromethylsulfonyl)imide, 1-butyl-1-methylpiperidinium bis(trifluoromethylsulfonyl)imide, and butyltrimethylammonium bis(trifluoromethylsulfonyl)imide. Data supporting the enhanced performance characteristics in a temperature range as demonstrated through Capacitance and ESR measurements over time, indicating high temperature utility and long term durability is provided in FIGS. 44A and B, FIGS. 45A and B, and FIGS. 46A and B.

[0129] In certain embodiments, the AES is trihexyltetradecylphosphonium bis(trifluoromethylsulfonyl)imide.

[0130] In certain embodiments, the AES is 1-butyl-1-methylpiperidinium bis(trifluoromethylsulfonyl)imide.

[0131] In certain embodiments, the AES is butyltrimethylammonium bis(trifluoromethylsulfonyl)imide.

[0132] In another embodiment, the novel electrolyte entities useful for the advanced electrolyte system (AES) of the present invention include any combination of cations presented in FIG. 8, selected from the group consisting of imidazolium and pyrrolidinium, wherein the various branch groups R_x (e.g., $R_1, R_2, R_3, \dots R_x$) may be selected from the group consisting of alkyl, heteroalkyl, alkenyl, heteroalkenyl, alkynyl, heteroalkynyl, halo, amino, nitro, cyano, hydroxyl, sulfate, sulfonate, and carbonyl, any of which is optionally substituted, and wherein at least two R_x are not H (i.e., such that the selection and orientation of the R groups produce the cationic species shown in FIG. 8); and the anion selected from the group consisting of tetrafluoroborate, bis(trifluoromethylsulfonyl)imide, tetracyanoborate, and trifluoromethanesulfonate. In one particular embodiment, the two R_x that are not H, are alkyl. Moreover, the noted cations

exhibit high thermal stability, as well as high conductivity and exhibit good electrochemical performance over a wide range of temperatures.

[0133] For example, given the combinations of cations and anions above, in a particular embodiment, the AES may be selected from the group consisting of 1-butyl-3-methylimidazolium tetrafluoroborate; 1-butyl-3-methylimidazolium bis(trifluoromethylsulfonyl)imide, 1-ethyl-3-methylimidazolium tetrafluoroborate; 1-ethyl-3-methylimidazolium tetracyanoborate; 1-hexyl-3-methylimidazolium tetracyanoborate; 1-butyl-1-methylpyrrolidinium bis(trifluoromethylsulfonyl)imide; 1-butyl-1-methylpyrrolidinium tris(pentafluoroethyl)trifluorophosphate; 1-butyl-1-methylpyrrolidinium tetracyanoborate, and 1-butyl-3-methylimidazolium trifluoromethanesulfonate.

[0134] In one embodiment, the AES is 1-butyl-3-methylimidazolium tetrafluoroborate.

[0135] In one embodiment, the AES is 1-butyl-3-methylimidazolium bis(trifluoromethylsulfonyl)imide.

[0136] In one embodiment, the AES is 1-ethyl-3-methylimidazolium tetrafluoroborate.

[0137] In one embodiment, the AES is 1-ethyl-3-methylimidazolium tetracyanoborate.

[0138] In one embodiment, the AES is 1-hexyl-3-methylimidazolium tetracyanoborate.

[0139] In one embodiment, the AES is 1-butyl-1-methylpyrrolidinium bis(trifluoromethyl sulfonyl)imide.

[0140] In one embodiment, the AES is 1-butyl-1-methylpyrrolidinium tris(pentafluoroethyl)trifluorophosphate.

[0141] In one embodiment, the AES is 1-butyl-1-methylpyrrolidinium tetracyanoborate.

[0142] In one embodiment, the AES is 1-butyl-3-methylimidazolium trifluoromethanesulfonate.

[0143] In another particular embodiment, one of the two R_x that are not H, is alkyl, e.g., methyl, and the other is an alkyl substituted with an alkoxy. Moreover, it has been found that cations having an N,O-acetal skeleton structure of the formula (1) in the molecule have high electrical conductivity, and that an ammonium cation included among these cations and having a pyrrolidine skeleton and an N,O-acetal group is especially high in electrical conductivity and solubility in organic solvents and supports relatively high voltage. As such, in one embodiment, the advanced electrolyte system comprises a salt of the following formula:



wherein R_1 and R_2 can be the same or different and are each alkyl, and X^- is an anion. In some embodiments, R_1 is straight-chain or branched alkyl having 1 to 4 carbon atoms, R_2 is methyl or ethyl, and X^- is a cyanoborate-containing anion **11**. In a specific embodiment, X^- comprises $[B(CN)]_4^-$ and R_2 is one of a methyl and an ethyl group. In another specific embodiment, R_1 and R_2 are both methyl. In addition, in one embodiment, cyanoborate anions **11**, X^- suited for the advanced electrolyte system of the present invention include, $[B(CN)_4]^-$ or $[BF_n(CN)_{4-n}]^-$, where $n=0, 1, 2$ or 3 .

[0144] Examples of cations of the AES of the present invention comprising a Novel Electrolyte Entity of formula (1), and which are composed of a quaternary ammonium cation shown in formula (I) and a cyanoborate anion are selected from N-methyl-N-methoxymethylpyrrolidinium (N-methoxymethyl-N-methylpyrrolidinium), N-ethyl-N-methoxymethylpyrrolidinium, N-methoxymethyl-N-n-propylpyrrolidinium, N-methoxymethyl-N-iso-propylpyrrolidinium, N-n-butyl-N-methoxymethylpyrrolidinium, N-iso-butyl-N-methoxymethylpyrrolidinium, N-tert-butyl-N-methoxymethylpyrrolidinium, N-ethoxymethyl-N-methylpyrrolidinium, N-ethyl-N-ethoxymethylpyrrolidinium (N-ethoxymethyl-N-ethylpyrrolidinium), N-ethoxymethyl-N-n-propylpyrrolidinium, N-ethoxymethyl-N-iso-propylpyrrolidinium, N-n-butyl-N-ethoxymethylpyrrolidinium, N-iso-butyl-N-ethoxymethylpyrrolidinium and N-tert-butyl-N-ethoxymethylpyrrolidinium. Other examples include N-methyl-N-methoxymethylpyrrolidinium (N-methoxymethyl-N-methylpyrrolidinium), N-ethyl-N-methoxymethylpyrrolidinium and N-ethoxymethyl-N-methylpyrrolidinium.

[0145] Additional examples of the cation of formula (1) in combination with additional anions may be selected from N-methyl-N-methoxymethylpyrrolidinium tetracyanoborate (N-methoxymethyl-N-methylpyrrolidinium tetracyanoborate), N-ethyl-N-methoxymethylpyrrolidinium tetracyanoborate, N-ethoxymethyl-N-methylpyrrolidinium tetracyanoborate, N-methyl-N-methoxymethylpyrrolidinium bistrifluoromethanesulfonylimide, (N-methoxymethyl-N-methylpyrrolidinium bistrifluoromethanesulfonylimide), N-ethyl-N-methoxymethylpyrrolidinium bistrifluoromethanesulfonylimide, N-ethoxymethyl-N-methylpyrrolidinium bistrifluoromethanesulfonylimide, N-methyl-N-methoxymethylpyrrolidinium trifluoromethanesulfonate (N-methoxymethyl-N-methyltrifluoromethanesulfonate).

[0146] When to be used as an electrolyte, the quaternary ammonium salt may be used as admixed with a suitable organic solvent. Useful solvents include cyclic carbonic acid esters, chain carbonic acid esters, phosphoric acid esters, cyclic ethers, chain ethers, lactone compounds, chain esters, nitrile compounds, amide compounds and sulfone compounds. Examples of such compounds are given below although the solvents to be used are not limited to these compounds.

[0147] Examples of cyclic carbonic acid esters are ethylene carbonate, propylene carbonate, butylene carbonate and the like, among which propylene carbonate is preferable.

[0148] Examples of chain carbonic acid esters are dimethyl carbonate, ethylmethyl carbonate, diethyl carbonate and the like, among which dimethyl carbonate and ethylmethyl carbonate are preferred.

[0149] Examples of phosphoric acid esters are trimethyl phosphate, triethyl phosphate, ethyldimethyl phosphate, diethylmethyl phosphate and the like. Examples of cyclic ethers are tetrahydrofuran, 2-methyltetrahydrofuran and the like. Examples of chain ethers are dimethoxyethane and the like. Examples of lactone compounds are γ -butyrolactone and the like. Examples of chain esters are methyl propionate, methyl acetate, ethyl acetate, methyl formate and the like. Examples of nitrile compounds are acetonitrile and the like. Examples of amide compounds are dimethylformamide and the like. Examples of sulfone compounds are sulfolane, methyl sulfolane and the like. Cyclic carbonic acid esters,

chain carbonic acid esters, nitrile compounds and sulfone compounds may be particularly desirable, in some embodiments.

[0150] These solvents may be used singly, or at least two kinds of solvents may be used in admixture. Examples of preferred organic solvent mixtures are mixtures of cyclic carbonic acid ester and chain carbonic acid ester such as those of ethylene carbonate and dimethyl carbonate, ethylene carbonate and ethylmethyl carbonate, ethylene carbonate and diethyl carbonate, propylene carbonate and dimethyl carbonate, propylene carbonate and ethylmethyl carbonate and propylene carbonate and diethyl carbonate, mixtures of chain carbonic acid esters such as dimethyl carbonate and ethylmethyl carbonate, and mixtures of sulfolane compounds such as sulfolane and methylsulfolane. More preferable are mixtures of ethylene carbonate and ethylmethyl carbonate, propylene carbonate and ethylmethyl carbonate, and dimethyl carbonate and ethylmethyl carbonate.

[0151] In some embodiments, when the quaternary ammonium salt of the invention is to be used as an electrolyte, the electrolyte concentration is at least 0.1 M, in some cases at least 0.5 M and may be at least 1 M. If the concentration is less than 0.1 M, low electrical conductivity will result, producing electrochemical devices of impaired performance. The upper limit concentration is a separation concentration when the electrolyte is a liquid salt at room temperature. When the solution does not separate, the limit concentration is 100%. When the salt is solid at room temperature, the limit concentration is the concentration at which the solution is saturated with the salt.

[0152] In certain embodiments, the advanced electrolyte system (AES) may be admixed with electrolytes other than those disclosed herein provided that such combination does not significantly affect the advantages achieved by utilization of the advanced electrolyte system, e.g., by altering the performance or durability characteristics by greater than 10%. Examples of electrolytes that may be suited to be admixed with the AES are alkali metal salts, quaternary ammonium salts, quaternary phosphonium salts, etc. These electrolytes may be used singly, or at least two kinds of them are usable in combination, as admixed with the AES disclosed herein. Useful alkali metal salts include lithium salts, sodium salts and potassium salts. Examples of such lithium salts are lithium hexafluorophosphate, lithium borofluoride, lithium perchlorate, lithium trifluoromethanesulfonate, sulfonylimide lithium, sulfonylmethide lithium and the like, which nevertheless are not limitative. Examples of useful sodium salts are sodium hexafluorophosphate, sodium borofluoride, sodium perchlorate, sodium trifluoromethanesulfonate, sulfonylimide sodium, sulfonylmethide sodium and the like. Examples of useful potassium salts are potassium hexafluorophosphate, potassium borofluoride, potassium perchlorate, potassium trifluoromethanesulfonate, sulfonylimide potassium, sulfonylmethide potassium and the like although these are not limitative.

[0153] Useful quaternary ammonium salts that may be used in the combinations described above (i.e., which do not significantly affect the advantages achieved by utilization of the advanced electrolyte system) include tetraalkylammonium salts, imidazolium salts, pyrazolium salts, pyridinium salts, triazolium salts, pyridazinium salts, etc., which are not limitative. Examples of useful tetraalkylammonium salts are tetraethylammonium tetracyanoborate, tetramethylammonium tetracyanoborate, tetrapropylammonium tetracya-

noborate, tetrabutylammonium tetracyanoborate, triethylmethylammonium tetracyanoborate, trimethylethylammonium tetracyanoborate, dimethyldiethylammonium tetracyanoborate, trimethylpropylammonium tetracyanoborate, trimethylbutylammonium tetracyanoborate, dimethylethylpropylammonium tetracyanoborate, methylethylpropylbutylammonium tetracyanoborate, N,N-dimethylpyrrolidinium tetracyanoborate, N-ethyl-N-methylpyrrolidinium tetracyanoborate, N-methyl-N-propylpyrrolidinium tetracyanoborate, N-ethyl-N-propylpyrrolidinium tetracyanoborate, N,N-dimethylpiperidinium tetracyanoborate, N-methyl-N-ethylpiperidinium tetracyanoborate, N-methyl-N-propylpiperidinium tetracyanoborate, N-ethyl-N-propylpiperidinium tetracyanoborate, N,N-dimethylmorpholinium tetracyanoborate, N-methyl-N-ethylmorpholinium tetracyanoborate, N-methyl-N-propylmorpholinium tetracyanoborate, N-ethyl-N-propylmorpholinium tetracyanoborate and the like, whereas these examples are not limitative.

[0154] Examples of imidazolium salts that may be used in the combinations described above (i.e., which do not significantly affect the advantages achieved by utilization of the advanced electrolyte system) include 1,3-dimethylimidazolium tetracyanoborate, 1-ethyl-3-methylimidazolium tetracyanoborate, 1,3-diethylimidazolium tetracyanoborate, 1,2-dimethyl-3-ethylimidazolium tetracyanoborate and 1,2-dimethyl-3-propylimidazolium tetracyanoborate, but are not limited to these. Examples of pyrazolium salts are 1,2-dimethylpyrazolium tetracyanoborate, 1-methyl-2-ethylpyrazolium tetracyanoborate, 1-propyl-2-methylpyrazolium tetracyanoborate and 1-methyl-2-butylpyrazolium tetracyanoborate, but are not limited to these. Examples of pyridinium salts are N-methylpyridinium tetracyanoborate, N-ethylpyridinium tetracyanoborate, N-propylpyridinium tetracyanoborate and N-butylpyridinium tetracyanoborate, but are not limited to these. Examples of triazolium salts are 1-methyltriazolium tetracyanoborate, 1-ethyltriazolium tetracyanoborate, 1-propyltriazolium tetracyanoborate and 1-butyltriazolium tetracyanoborate, but are not limited to these. Examples of pyridazinium salts are 1-methylpyridazinium tetracyanoborate, 1-ethylpyridazinium tetracyanoborate, 1-propylpyridazinium tetracyanoborate and 1-butylpyridazinium tetracyanoborate, but are not limited to these. Examples of quaternary phosphonium salts are tetraethylphosphonium tetracyanoborate, tetramethylphosphonium tetracyanoborate, tetrapropylphosphonium tetracyanoborate, tetrabutylphosphonium tetracyanoborate, triethylmethylphosphonium tetrafluoroborate, trimethylethylphosphonium tetracyanoborate, dimethyldiethylphosphonium tetracyanoborate, trimethylpropylphosphonium tetracyanoborate, trimethylbutylphosphonium tetracyanoborate, dimethylethylpropylphosphonium tetracyanoborate, methylethylpropylbutylphosphonium tetracyanoborate, but are not limited to these.

[0155] In certain embodiments, the novel electrolytes selected herein for use the advanced electrolyte systems may also be purified. Such purification may be performed using art-recognized techniques or the techniques provided herein. This purification may further improve the characteristics of the Novel Electrolyte Entities described herein.

[0156] ii. Highly Purified Electrolytes

[0157] The advanced electrolyte systems of the present comprise, in one embodiment, certain highly purified electrolytes for use in high temperature ultracapacitors. In cer-

tain embodiments. The highly purified electrolytes that comprise the AES of the present invention are those electrolytes described below as well as those novel electrolytes described above purified by the purification process described herein. The purification methods provided herein produce impurity levels that afford an advanced electrolyte system with enhanced properties for use in high temperature applications, e.g., high temperature ultracapacitors, for example in a temperature range of about 80 degrees Celsius to about 210 degrees Celsius, e.g., about 80 degrees Celsius to about 200 degrees Celsius, e.g., about 80 degrees Celsius to about 190 degrees Celsius e.g., about 80 degrees Celsius to about 180 degrees Celsius e.g., about 80 degrees Celsius to about 170 degrees Celsius e.g., about 80 degrees Celsius to about 160 degrees Celsius e.g., about 80 degrees Celsius to about 150 degrees Celsius e.g., about 85 degrees Celsius to about 145 degrees Celsius e.g., about 90 degrees Celsius to about 140 degrees Celsius e.g., about 95 degrees Celsius to about 135 degrees Celsius e.g., about 100 degrees Celsius to about 130 degrees Celsius e.g., about 105 degrees Celsius to about 125 degrees Celsius e.g., about 110 degrees Celsius to about 120 degrees Celsius.

[0158] Obtaining improved properties of the ultracapacitor **10** results in a requirement for better electrolyte systems than presently available. For example, it has been found that increasing the operational temperature range may be achieved by the significant reduction/removal of impurities from certain forms of known electrolytes. Impurities of particular concern include water, halide ions (chloride, bromide, fluoride, iodide), free amines (ammonia), sulfate, and metal cations (Ag, Al, Ba, Ca, Cd, Co, Cr, Cu, Fe, K, Li, Mg, Mn, Mo, Na, Ni, Pb, Sr, Ti, Zn). The highly purified electrolyte product of such purification provides electrolytes that are surprisingly far superior to the unpurified electrolyte, and as such, fall with the advanced electrolyte systems of the present invention.

[0159] In a particular embodiment, the present invention provides a purified mixture of cation **9** and anion **11** and, in some instances a solvent, which may serve as the AES of the present invention which comprises less than about 5000 parts per million (ppm) of chloride ions; less than about 1000 ppm of fluoride ions; and/or less than about 1000 ppm of water (e.g. less than about 2000 ppm of chloride ions; less than about less than about 200 ppm of fluoride ions; and/or less than about 200 ppm of water, e.g. less than about 1000 ppm of chloride ions; less than about less than about 100 ppm of fluoride ions; and/or less than about 100 ppm of water, e.g. less than about 500 ppm of chloride ions; less than about less than about 50 ppm of fluoride ions; and/or less than about 50 ppm of water, e.g. less than about 780 parts per million of chloride ions; less than about 11 parts per million of fluoride ions; and less than about 20 parts per million of water.)

[0160] Generally, impurities in the purified electrolyte are removed using the methods of purification described herein. For example, in some embodiments, a total concentration of halide ions (chloride, bromide, fluoride, iodide), may be reduced to below about 1,000 ppm. A total concentration of metallic species (e.g., Cd, Co, Cr, Cu, Fe, K, Li, Mo, Na, Ni, Pb, Zn, including an at least one of an alloy and an oxide thereof), may be reduced to below about 1,000 ppm. Further, impurities from solvents and precursors used in the synthesis process may be reduced to below about 1,000 ppm and can include, for example, bromoethane, chloroethane, 1-bro-

mobutane, 1-chlorobutane, 1-methylimidazole, ethyl acetate, methylene chloride and so forth.

[0161] In some embodiments, the impurity content of the ultracapacitor **10** has been measured using ion selective electrodes and the Karl Fischer titration procedure, which has been applied to electrolyte **6** of the ultracapacitor **10**. In certain embodiments, it has been found that the total halide content in the ultracapacitor **10** according to the teachings herein has been found to be less than about 200 ppm of halides (Cl^- and F^-) and water content is less than about 100 ppm.

[0162] Impurities can be measured using a variety of techniques, such as, for example, Atomic Absorption Spectrometry (AAS), Inductively Coupled Plasma-Mass Spectrometry (ICPMS), or simplified solubilizing and electrochemical sensing of trace heavy metal oxide particulates. AAS is a spectro-analytical procedure for the qualitative and quantitative determination of chemical elements employing the absorption of optical radiation (light) by free atoms in the gaseous state. The technique is used for determining the concentration of a particular element (the analyte) in a sample to be analyzed. AAS can be used to determine over seventy different elements in solution or directly in solid samples. ICPMS is a type of mass spectrometry that is highly sensitive and capable of the determination of a range of metals and several non-metals at concentrations below one part in 10^{12} (part per trillion). This technique is based on coupling together an inductively coupled plasma as a method of producing ions (ionization) with a mass spectrometer as a method of separating and detecting the ions. ICPMS is also capable of monitoring isotopic speciation for the ions of choice.

[0163] Additional techniques may be used for analysis of impurities. Some of these techniques are particularly advantageous for analyzing impurities in solid samples. Ion Chromatography (IC) may be used for determination of trace levels of halide impurities in the electrolyte **6** (e.g., an ionic liquid). One advantage of Ion Chromatography is that relevant halide species can be measured in a single chromatographic analysis. A Dionex AS9-HC column using an eluent consisting 20 mM NaOH and 10% (v/v) acetonitrile is one example of an apparatus that may be used for the quantification of halides from the ionic liquids. A further technique is that of X-ray fluorescence.

[0164] X-ray fluorescence (XRF) instruments may be used to measure halogen content in solid samples. In this technique, the sample to be analyzed is placed in a sample cup and the sample cup is then placed in the analyzer where it is irradiated with X-rays of a specific wavelength. Any halogen atoms in the sample absorb a portion of the X-rays and then reflect radiation at a wavelength that is characteristic for a given halogen. A detector in the instrument then quantifies the amount of radiation coming back from the halogen atoms and measures the intensity of radiation. By knowing the surface area that is exposed, concentration of halogens in the sample can be determined. A further technique for assessing impurities in a solid sample is that of pyrolysis.

[0165] Adsorption of impurities may be effectively measured through use of pyrolysis and microcoulometers. Microcoulometers are capable of testing almost any type of material for total chlorine content. As an example, a small amount of sample (less than 10 milligrams) is either injected or placed into a quartz combustion tube where the temperature ranges from about 600 degrees Celsius to about 1,000

degrees Celsius. Pure oxygen is passed through the quartz tube and any chlorine containing components are combusted completely. The resulting combustion products are swept into a titration cell where the chloride ions are trapped in an electrolyte solution. The electrolyte solution contains silver ions that immediately combine with any chloride ions and drop out of solution as insoluble silver chloride. A silver electrode in the titration cell electrically replaces the used up silver ions until the concentration of silver ions is back to where it was before the titration began. By keeping track of the amount of current needed to generate the required amount of silver, the instrument is capable of determining how much chlorine was present in the original sample. Dividing the total amount of chlorine present by the weight of the sample gives the concentration of chlorine that is actually in the sample. Other techniques for assessing impurities may be used.

[0166] Surface characterization and water content in the electrode **3** may be examined, for example, by infrared spectroscopy techniques. The four major absorption bands at around 1130, 1560, 3250 and 2300 cm^{-1} , correspond to $\nu\text{C}=\text{O}$ in, $\nu\text{C}=\text{C}$ in aryl, $\nu\text{O}-\text{H}$ and $\nu\text{C}-\text{N}$, respectively. By measuring the intensity and peak position, it is possible to quantitatively identify the surface impurities within the electrode **3**.

[0167] Another technique for identifying impurities in the electrolyte **6** and the ultracapacitor **10** is Raman spectroscopy. This spectroscopic technique relies on inelastic scattering, or Raman scattering, of monochromatic light, usually from a laser in the visible, near infrared, or near ultraviolet range. The laser light interacts with molecular vibrations, phonons or other excitations in the system, resulting in the energy of the laser photons being shifted up or down. Thus, this technique may be used to characterize atoms and molecules within the ultracapacitor **10**. A number of variations of Raman spectroscopy are used, and may prove useful in characterizing contents the ultracapacitor **10**.

[0168] iii. Enhanced Electrolyte Combinations

[0169] The advanced electrolyte systems of the present comprise, in one embodiment, include certain enhanced electrolyte combinations suitable for use in temperature ranges from -40 degrees Celsius to 210 degrees Celsius, e.g., -40 degrees Celsius to 150 degrees Celsius, e.g., -30 degrees Celsius to 150 degrees Celsius, e.g., -30 degrees Celsius to 140 degrees Celsius, e.g., -20 degrees Celsius to 140 degrees Celsius, e.g., -20 degrees Celsius to 130 degrees Celsius, e.g., -10 degrees Celsius to 130 degrees Celsius, e.g., -10 degrees Celsius to 120 degrees Celsius, e.g., 0 degrees Celsius to 120 degrees Celsius, e.g., 0 degrees Celsius to 110 degrees Celsius, e.g., 0 degrees Celsius to 100 degrees Celsius, e.g., 0 degrees Celsius to 90 degrees Celsius, e.g., 0 degrees Celsius to 80 degrees Celsius, e.g., 0 degrees Celsius to 70 degrees Celsius, without a significant drop in performance or durability.

[0170] Generally, a higher degree of durability at a given temperature may be coincident with a higher degree of voltage stability at a lower temperature. Accordingly, the development of a high temperature durability AES, with enhanced electrolyte combinations, generally leads to simultaneous development of high voltage, but lower temperature AES, such that these enhanced electrolyte combinations described herein may also be useful at higher voltages, and thus higher energy densities, but at lower temperatures.

[0171] In one embodiment, the present invention provides an enhanced electrolyte combination suitable for use in an energy storage cell, e.g., an ultracapacitor, comprising a novel mixture of electrolytes selected from the group consisting of an ionic liquid mixed with a second ionic liquid, an ionic liquid mixed with an organic solvent, and an ionic liquid mixed with a second ionic liquid and an organic solvent:

[0172] wherein each ionic liquid is selected from the salt of any combination of the following cations and anions, wherein the cations are selected from the group consisting of 1-butyl-3-methylimidazolium, 1-ethyl-3-methylimidazolium, 1-hexyl-3-methylimidazolium, 1-butyl-1-methylpyrrolidinium, butyltrimethylammonium, 1-butyl-1-methylpyrrolidinium, trihexyltetradecylphosphonium, and 1-butyl-3-methylimidazolium; and the anions are selected from the group consisting of tetrafluoroborate, bis(trifluoromethylsulfonyl)imide, tetracyanoborate, and trifluoromethanesulfonate; and

[0173] wherein the organic solvent is selected from the group consisting of linear sulfones (e.g., ethyl isopropyl sulfone, ethyl isobutyl sulfone, ethyl methyl sulfone, methyl isopropyl sulfone, isopropyl isobutyl sulfone, isopropyl s-butyl sulfone, butyl isobutyl sulfone, and dimethyl sulfone), linear carbonates (e.g., ethylene carbonate, propylene carbonate, and dimethyl carbonate), and acetonitrile.

[0174] For example, given the combinations of cations and anions above, each ionic liquid may be selected from the group consisting of 1-butyl-3-methylimidazolium tetrafluoroborate; 1-butyl-3-methylimidazolium bis(trifluoromethylsulfonyl)imide; 1-ethyl-3-methylimidazolium tetrafluoroborate; 1-ethyl-3-methylimidazolium tetracyanoborate; 1-hexyl-3-methylimidazolium tetracyanoborate; 1-butyl-1-methylpyrrolidinium bis(trifluoromethylsulfonyl)imide; 1-butyl-1-methylpyrrolidinium tris(pentafluoroethyltrifluorophosphate); 1-butyl-1-methylpyrrolidinium tetracyanoborate; trihexyltetradecylphosphonium bis(trifluoromethylsulfonyl)imide, 1-butyl-1-methylpiperidinium bis(trifluoromethylsulfonyl)imide, butyltrimethylammonium bis(trifluoromethylsulfonyl)imide, and 1-butyl-3-methylimidazolium trifluoromethanesulfonate.

[0175] In certain embodiments, the ionic liquid is 1-butyl-3-methylimidazolium tetrafluoroborate.

[0176] In certain embodiments, the ionic liquid is 1-butyl-3-methylimidazolium bis(trifluoromethylsulfonyl)imide.

[0177] In certain embodiments, the ionic liquid is 1-ethyl-3-methylimidazolium tetrafluoroborate.

[0178] In certain embodiments, the ionic liquid is 1-ethyl-3-methylimidazolium tetracyanoborate.

[0179] In certain embodiments, the ionic liquid is 1-hexyl-3-methylimidazolium tetracyanoborate.

[0180] In certain embodiments, the ionic liquid is 1-butyl-1-methylpyrrolidinium bis(trifluoromethylsulfonyl)imide.

[0181] In one embodiment, the ionic liquid is 1-butyl-1-methylpyrrolidinium tris(pentafluoroethyl)trifluorophosphate.

[0182] In certain embodiments, the ionic liquid is 1-butyl-1-methylpyrrolidinium tetracyanoborate.

[0183] In certain embodiments, the ionic liquid is trihexyltetradecylphosphonium bis(trifluoromethylsulfonyl)imide.

[0184] In certain embodiments, the ionic liquid is 1-butyl-1-methylpiperidinium bis(trifluoromethylsulfonyl)imide.

[0185] In certain embodiments, the ionic liquid is butyltrimethylammonium bis(trifluoromethylsulfonyl)imide

[0186] In certain embodiments, the ionic liquid is 1-butyl-3-methylimidazolium trifluoromethanesulfonate.

[0187] In certain embodiments, the organic solvent is selected from ethyl isopropyl sulfone, ethyl isobutyl sulfone, ethyl methyl sulfone, methyl isopropyl sulfone, isopropyl isobutyl sulfone, isopropyl s-butyl sulfone, butyl isobutyl sulfone, or dimethyl sulfone, linear sulfones.

[0188] In certain embodiments, the organic solvent is selected from polypropylene carbonate, propylene carbonate, dimethyl carbonate, ethylene carbonate.

[0189] In certain embodiments, the organic solvent is acetonitrile.

[0190] In certain embodiments, the enhanced electrolyte composition is an ionic liquid with an organic solvent, wherein the organic solvent is 55%-90%, e.g., 37.5%, by volume of the composition.

[0191] In certain embodiments, the enhanced electrolyte composition is an ionic liquid with a second ionic liquid, wherein one ionic liquid is 5%-90%, e.g., 60%, by volume of the composition.

[0192] The enhanced electrolyte combinations of the present invention provide a wider temperature range performance for an individual capacitor (e.g. without a significant drop in capacitance and/or increase in ESR when transitioning between two temperatures, e.g. without more than a 90% decrease in capacitance and/or a 1000% increase in ESR when transitioning from about +30° C. to about -40° C.), and increased temperature durability for an individual capacitor (e.g., less than a 50% decrease in capacitance at a given temperature after a given time and/or less than a 100% increase in ESR at a given temperature after a given time, and/or less than 10 A/L of leakage current at a given temperature after a given time, e.g., less than a 40% decrease in capacitance and/or a 75% increase in ESR, and/or less than 5 A/L of leakage current, e.g., less than a 30% decrease in capacitance and/or a 50% increase in ESR, and/or less than 1 A/L of leakage current). FIGS. 47A&B, FIGS. 48A&B and FIG. 49 depicts the behavior of an ionic liquid from the above listing at 125 degrees Celsius, a 37.5% organic solvent-ionic liquid (same) v/v at 125 degrees Celsius, and the same composition at -40 degrees Celsius, respectively.

[0193] Without wishing to be bound by theory, the combinations described above provide enhanced eutectic properties that affect the freezing point of the advanced electrolyte system to afford ultracapacitors that operate within performance and durability standards at temperatures of down to -40 degrees Celsius.

[0194] As described above for the novel electrolytes of the present invention, in certain embodiments, the advanced electrolyte system (AES) may be admixed with electrolytes provided that such combination does not significantly affect the advantages achieved by utilization of the advanced electrolyte system.

[0195] In certain embodiments, the enhanced electrolyte combinations are selected herein for use the advanced electrolyte systems may also be purified. Such purification may be performed using art-recognized techniques or techniques provided herein.

[0196] B. Electrodes

[0197] The EDLC includes at least one pair of electrodes 3 (where the electrodes 3 may be referred to as a negative

electrode **3** and a positive electrode **3**, merely for purposes of referencing herein). When assembled into the ultracapacitor **10**, each of the electrodes **3** presents a double layer of charge at an electrolyte interface. In some embodiments, a plurality of electrodes **3** is included (for example, in some embodiments, at least two pairs of electrodes **3** are included). However, for purposes of discussion, only one pair of electrodes **3** are shown. As a matter of convention herein, at least one of the electrodes **3** uses a carbon-based energy storage media **1** (as discussed further herein) to provide energy storage. However, for purposes of discussion herein, it is generally assumed that each of the electrodes includes the carbon-based energy storage media **1**.

[0198] i. Current Collector

[0199] Each of the electrodes **3** includes a respective current collector **2** (also referred to as a “charge collector”). In some embodiments, the electrodes **3** are separated by a separator **5**. In general, the separator **5** is a thin structural material (usually a sheet) used to separate the negative electrode **3** from the positive electrode **3**. The separator **5** may also serve to separate pairs of the electrodes **3**. Note that, in some embodiments, the carbon-based energy storage media **1** may not be included on one or both of the electrodes **3**. That is, in some embodiments, a respective electrode **3** might consist of only the current collector **2**. The material used to provide the current collector **2** could be roughened, anodized or the like to increase a surface area thereof. In these embodiments, the current collector **2** alone may serve as the electrode **3**. With this in mind, however, as used herein, the term “electrode **3**” generally refers to a combination of the energy storage media **1** and the current collector **2** (but this is not limiting, for at least the foregoing reason).

[0200] ii. Energy Storage Media

[0201] In the exemplary ultracapacitor **10**, the energy storage media **1** is formed of carbon nanotubes. The energy storage media **1** may include other carbonaceous materials including, for example, activated carbon, carbon fibers, rayon, graphene, aerogel, carbon cloth, and a plurality of forms of carbon nanotubes. Activated carbon electrodes can be manufactured, for example, by producing a carbon base material by carrying out a first activation treatment to a carbon material obtained by carbonization of a carbon compound, producing a formed body by adding a binder to the carbon base material, carbonizing the formed body, and finally producing an active carbon electrode by carrying out a second activation treatment to the carbonized formed body. Carbon fiber electrodes can be produced, for example, by using paper or cloth pre-form with high surface area carbon fibers.

[0202] In an exemplary method for fabricating carbon nanotubes, an apparatus for producing an aligned carbon-nanotube aggregate includes apparatus for synthesizing the aligned carbon-nanotube aggregate on a base material having a catalyst on a surface thereof. The apparatus includes a formation unit that processes a formation step of causing an environment surrounding the catalyst to be an environment of a reducing gas and heating at least either the catalyst or the reducing gas; a growth unit that processes a growth step of synthesizing the aligned carbon-nanotube aggregate by causing the environment surrounding the catalyst to be an environment of a raw material gas and by heating at least either the catalyst or the raw material gas; and a transfer unit that transfers the base material at least from the formation

unit to the growth unit. A variety of other methods and apparatus may be employed to provide the aligned carbon-nanotube aggregate.

[0203] In some embodiments, material used to form the energy storage media **1** may include material other than pure carbon (and the various forms of carbon as may presently exist or be later devised). That is, various formulations of other materials may be included in the energy storage media **1**. More specifically, and as a non-limiting example, at least one binder material may be used in the energy storage media **1**, however, this is not to suggest or require addition of other materials (such as the binder material). In general, however, the energy storage media **1** is substantially formed of carbon, and may therefore be referred to herein as a “carbonaceous material,” as a “carbonaceous layer” and by other similar terms. In short, although formed predominantly of carbon, the energy storage media **1** may include any form of carbon (as well as any additives or impurities as deemed appropriate or acceptable) to provide for desired functionality as energy storage media **1**.

[0204] In one set of embodiments, the carbonaceous material includes at least about 60% elemental carbon by mass, and in other embodiments at least about 75%, 85%, 90%, 95% or 98% by mass elemental carbon.

[0205] Carbonaceous material can include carbon in a variety forms, including carbon black, graphite, and others. The carbonaceous material can include carbon particles, including nanoparticles, such as nanotubes, nanorods, graphene sheets in sheet form, and/or formed into cones, rods, spheres (buckyballs) and the like.

[0206] Some embodiments of various forms of carbonaceous material suited for use in energy storage media **1** are provided herein as examples. These embodiments provide robust energy storage and are well suited for use in the electrode **3**. It should be noted that these examples are illustrative and are not limiting of embodiments of carbonaceous material suited for use in energy storage media **1**.

[0207] In certain embodiments, the porosity of the energy storage media **1** of each electrode may be selected based on the size of the respective electrolyte to improve the performance of the capacitor.

[0208] An exemplary process for complimenting the energy storage media **1** with the current collector **2** to provide the electrode **3** is now provided. Referring now to FIG. 2, a substrate **14** that is host to carbonaceous material in the form of carbon nanotube aggregate (CNT) is shown. In the embodiment shown, the substrate **14** includes a base material **17** with a thin layer of a catalyst **18** disposed thereon.

[0209] In general, the substrate **14** is at least somewhat flexible (i.e., the substrate **14** is not brittle), and is fabricated from components that can withstand environments for deposition of the energy storage media **1** (e.g., CNT). For example, the substrate **14** may withstand a high-temperature environment of between about 400 degrees Celsius to about 1,100 degrees Celsius. A variety of materials may be used for the substrate **14**, as determined appropriate.

[0210] Refer now to FIG. 3. Once the energy storage media **1** (e.g., CNT) has been fabricated on the substrate **14**, the current collector **2** may be disposed thereon. In some embodiments, the current collector **2** is between about 0.5 micrometers (μm) to about 25 micrometers (μm) thick. In some embodiments, the current collector **2** is between about 20 micrometers (μm) to about 40 micrometers (μm) thick.

The current collector **2** may appear as a thin layer, such as layer that is applied by chemical vapor deposition (CVD), sputtering, e-beam, thermal evaporation or through another suitable technique. Generally, the current collector **2** is selected for its properties such as conductivity, being electrochemically inert and compatible with the energy storage media **1** (e.g., CNT). Some exemplary materials include aluminum, platinum, gold, tantalum, titanium, and may include other materials as well as various alloys.

[0211] Once the current collector **2** is disposed onto the energy storage media **1** (e.g., CNT), an electrode element **15** is realized. Each electrode element **15** may be used individually as the electrode **3**, or may be coupled to at least another electrode element **15** to provide for the electrode **3**.

[0212] Once the current collector **2** has been fabricated according to a desired standard, post-fabrication treatment may be undertaken. Exemplary post-treatment includes heating and cooling of the energy storage media **1** (e.g., CNT) in a slightly oxidizing environment. Subsequent to fabrication (and optional post-treatment), a transfer tool may be applied to the current collector **2**. Reference may be had to FIG. 4.

[0213] FIG. 4 illustrates application of transfer tool **13** to the current collector **2**. In this example, the transfer tool **13** is a thermal release tape, used in a “dry” transfer method. Exemplary thermal release tape is manufactured by NITTO DENKO CORPORATION of Fremont, Calif. and Osaka, Japan. One suitable transfer tape is marketed as REVALPHA. This release tape may be characterized as an adhesive tape that adheres tightly at room temperature and can be peeled off by heating. This tape, and other suitable embodiments of thermal release tape, will release at a predetermined temperature. Advantageously, the release tape does not leave a chemically active residue on the electrode element **15**.

[0214] In another process, referred to as a “wet” transfer method, tape designed for chemical release may be used. Once applied, the tape is then removed by immersion in a solvent. The solvent is designed to dissolve the adhesive.

[0215] In other embodiments, the transfer tool **13** uses a “pneumatic” method, such as by application of suction to the current collector **2**. The suction may be applied, for example, through a slightly oversized paddle having a plurality of perforations for distributing the suction. In another example, the suction is applied through a roller having a plurality of perforations for distributing the suction. Suction driven embodiments offer advantages of being electrically controlled and economic as consumable materials are not used as a part of the transfer process. Other embodiments of the transfer tool **13** may be used.

[0216] Once the transfer tool **13** has been temporarily coupled to the current collector **2**, the electrode element **15** is gently removed from the substrate **14** (see FIGS. 4 and 5). The removal generally involves peeling the energy storage media **1** (e.g., CNT) from the substrate **14**, beginning at one edge of the substrate **14** and energy storage media **1** (e.g., CNT).

[0217] Subsequently, the transfer tool **13** may be separated from the electrode element **15** (see FIG. 6). In some embodiments, the transfer tool **13** is used to install the electrode element **15**. For example, the transfer tool **13** may be used to place the electrode element **15** onto the separator **5**. In general, once removed from the substrate **14**, the electrode element **15** is available for use.

[0218] In instances where a large electrode **3** is desired, a plurality of the electrode elements **15** may be mated. Reference may be had to FIG. 7. As shown in FIG. 7, a plurality of the electrode elements **15** may be mated by, for example, coupling a coupling **52** to each electrode element **15** of the plurality of electrode elements **15**. The mated electrode elements **15** provide for an embodiment of the electrode **3**.

[0219] In some embodiments, the coupling **22** is coupled to each of the electrode elements **15** at a weld **21**. Each of the welds **21** may be provided as an ultrasonic weld **21**. It has been found that ultrasonic welding techniques are particularly well suited to providing each weld **21**. That is, in general, the aggregate of energy storage media **1** (e.g., CNT) is not compatible with welding, where only a nominal current collector, such as disclosed herein is employed. As a result, many techniques for joining electrode elements **15** are disruptive, and damage the element **15**. However, in other embodiments, other forms of coupling are used, and the coupling **22** is not a weld **21**.

[0220] The coupling **22** may be a foil, a mesh, a plurality of wires or in other forms. Generally, the coupling **22** is selected for properties such as conductivity and being electrochemically inert. In some embodiments, the coupling **22** is fabricated from the same material(s) as are present in the current collector **2**.

[0221] In some embodiments, the coupling **22** is prepared by removing an oxide layer thereon. The oxide may be removed by, for example, etching the coupling **22** before providing the weld **21**. The etching may be accomplished, for example, with potassium hydroxide (KOH). The electrode **3** may be used in a variety of embodiments of the ultracapacitor **10**. For example, the electrode **3** may be rolled up into a “jelly roll” type of energy storage.

[0222] C. Separator

[0223] The separator **5** may be fabricated from various materials. In some embodiments, the separator **5** is non-woven glass. The separator **5** may also be fabricated from fiberglass, ceramics and fluoro-polymers, such as polytetrafluoroethylene (PTFE), commonly marketed as TEFLON™ by DuPont Chemicals of Wilmington, Del. For example, using non-woven glass, the separator **5** can include main fibers and binder fibers each having a fiber diameter smaller than that of each of the main fibers and allowing the main fibers to be bonded together.

[0224] For longevity of the ultracapacitor **10** and to assure performance at high temperature, the separator **5** should have a reduced amount of impurities and in particular, a very limited amount of moisture contained therein. In particular, it has been found that a limitation of about 200 ppm of moisture is desired to reduce chemical reactions and improve the lifetime of the ultracapacitor **10**, and to provide for good performance in high temperature applications. Some embodiments of materials for use in the separator **5** include polyamide, polytetrafluoroethylene (PTFE), polyetheretherketone (PEEK), aluminum oxide (Al₂O₃), fiberglass, and glass-reinforced plastic (GRP).

[0225] In general, materials used for the separator **5** are chosen according to moisture content, porosity, melting point, impurity content, resulting electrical performance, thickness, cost, availability and the like. In some embodiments, the separator **5** is formed of hydrophobic materials.

[0226] Accordingly, procedures may be employed to ensure excess moisture is eliminated from each separator **5**. Among other techniques, a vacuum drying procedure may

be used. A selection of materials for use in the separator **5** is provided in Table 1. Some related performance data is provided in Table 2.

TABLE 1

Separator Materials				
Material	Melting point	PPM H ₂ O unbaked	PPM H ₂ O baked	Vacuum dry procedure
Polyamide	256° C.	2052	20	180° C. for 24 h
Polytetrafluoroethylene, PTFE	327° C.	286	135	150° C. for 24 h
Polyether ether ketone, PEEK	256° C.	130	50	215° C. for 12 h
Aluminum Oxide, Al ₂ O ₃	330° C.	1600	100	215° C. for 24 h
Fiberglass (GRP)	320° C.	2000	167	215° C. for 12 h

TABLE 2

Separator Performance Data					
Material	μm	Porosity	ESR 1 st test (Ω)	ESR 2 nd test (Ω)	After 10 CV
Polyamide	42	Nonwoven	1.069	1.069	1.213
PEEK	45	Mesh	1.665	1.675	2.160
PEEK 60%	25	60%	0.829	0.840	0.883
Fiberglass (GRP)	160	Nonwoven	0.828	0.828	0.824
Aluminum Oxide, Al ₂ O ₃	25	—	2.400	2.400	2.400

[0227] In order to collect data for Table 2, two electrodes **3**, based on carbonaceous material, were provided. The electrodes **3** were disposed opposite to and facing each other. Each of the separators **5** were placed between the electrodes **3** to prevent a short circuit. The three components were then wetted with electrolyte **6** and compressed together. Two aluminum bars and PTFE material was used as an external structure to enclose the resulting ultracapacitor **10**.

[0228] The ESR 1st test and ESR 2nd test were performed with the same configuration one after the other. The second test was run five minutes after the first test, leaving time for the electrolyte **6** to further soak into the components.

[0229] In certain embodiments, the ultracapacitor **10** does not include the separator **5**. For example, in particular embodiments, such as where the electrodes **3** are assured of physical separation by a geometry of construction, it suffices to have electrolyte **6** alone between the electrodes **3**. More specifically, and as an example of physical separation, one such ultracapacitor **10** may include electrodes **3** that are disposed within a housing such that separation is assured on a continuous basis. A bench-top example would include an ultracapacitor **10** provided in a beaker.

[0230] D. Storage Cell

[0231] Once assembled, the electrodes **3** and the separator **5** provide a storage cell **12**. Generally, the storage cell **12** is formed into one of a wound form or prismatic form which is then packaged into a cylindrical or prismatic housing **7**. Once the electrolyte **6** has been included, the housing **7** may be hermetically sealed. In various examples, the package is hermetically sealed by techniques making use of laser, ultrasonic, and/or welding technologies. In addition to providing robust physical protection of the storage cell **12**, the housing **7** is configured with external contacts to provide

electrical communication with respective terminals **8** within the housing **7**. Each of the terminals **8**, in turn, provides electrical access to energy stored in the energy storage media **1**, generally through electrical leads which are coupled to the energy storage media **1**.

[0232] Generally, the ultracapacitor **10** disclosed herein is capable of providing a hermetic seal that has a leak rate no greater than about 5.0×10^{-6} atm-cc/sec, and may exhibit a leak rate no higher than about 5.0×10^{-10} atm-cc/sec. It is also considered that performance of a successfully hermetic seal is to be judged by the user, designer or manufacturer as appropriate, and that “hermetic” ultimately implies a standard that is to be defined by a user, designer, manufacturer or other interested party.

[0233] Leak detection may be accomplished, for example, by use of a tracer gas. Using tracer gas such as helium for leak testing is advantageous as it is a dry, fast, accurate and non destructive method. In one example of this technique, the ultracapacitor **10** is placed into an environment of helium. The ultracapacitor **10** is subjected to pressurized helium. The ultracapacitor **10** is then placed into a vacuum chamber that is connected to a detector capable of monitoring helium presence (such as an atomic absorption unit). With knowledge of pressurization time, pressure and internal volume, the leak rate of the ultracapacitor **10** may be determined.

[0234] In some embodiments, at least one lead (which may also be referred to herein as a “tab”) is electrically coupled to a respective one of the current collectors **2**. A plurality of the leads (accordingly to a polarity of the ultracapacitor **10**) may be grouped together and coupled to into a respective terminal **8**. In turn, the terminal **8** may be coupled to an electrical access, referred to as a “contact” (e.g., one of the housing **7** and an external electrode (also referred to herein for convention as a “feed-through” or “pin”). Reference may be had to FIGS. **28** and **32-34**.

[0235] E. Housing

[0236] FIG. **11** depicts aspects of an exemplary housing **7**. Among other things, the housing **7** provides structure and physical protection for the ultracapacitor **10**. In this example, the housing **7** includes an annular cylindrically shaped body **20** and a complimentary cap **24**. In this embodiment, the cap **24** includes a central portion that has been removed and filled with an electrical insulator **26**. A cap feed-through **19** penetrates through the electrical insulator **26** to provide users with access to the stored energy. Moreover, the housing may also include an inner bather **30**.

[0237] Although this example depicts only one feed-through **19** on the cap **24**, it should be recognized that the construction of the housing **7** is not limited by the embodiments discussed herein. For example, the cap **24** may include a plurality of feed-throughs **19**. In some embodiments, the body **20** includes a second, similar cap **24** at the opposing end of the annular cylinder. Further, it should be recognized that the housing **7** is not limited to embodiments having an annular cylindrically shaped body **20**. For example, the housing **7** may be a clamshell design, a prismatic design, a pouch, or of any other design that is appropriate for the needs of the designer, manufacturer or user.

[0238] Referring now to FIG. **12**, there is shown an exemplary energy storage cell **12**. In this example, the energy storage cell **12** is a “jelly roll” type of energy storage. In these embodiments, the energy storage materials are

rolled up into a tight package. A plurality of leads generally form each terminal **8** and provide electrical access to the appropriate layer of the energy storage cell **12**. Generally, when assembled, each terminal **8** is electrically coupled to the housing **7** (such as to a respective feed-through **19** and/or directly to the housing **7**). The energy storage cell **12** may assume a variety of forms. There are generally at least two plurality of leads (e.g., terminals **8**), one for each current collector **2**. For simplicity, only one of terminal **8** is shown in FIGS. **12**, **15** and **17**.

[0239] A highly efficient seal of the housing **7** is desired. That is, preventing intrusion of the external environment (such as air, humidity, etc.) helps to maintain purity of the components of the energy storage cell **12**. Further, this prevents leakage of electrolyte **6** from the energy storage cell **12**.

[0240] In this example, the cap **24** is fabricated with an outer diameter that is designed for fitting snugly within an inner diameter of the body **20**. When assembled, the cap **24** may be welded into the body **20**, thus providing users with a hermetic seal. Exemplary welding techniques include laser welding and TIG welding, and may include other forms of welding as deemed appropriate.

[0241] Common materials for the housing **7** include stainless steel, aluminum, tantalum, titanium, nickel, copper, tin, various alloys, laminates, and the like. Structural materials, such as some polymer-based materials may be used in the housing **7** (generally in combination with at least some metallic components).

[0242] In some embodiments, a material used for construction of the body **20** includes aluminum, which may include any type of aluminum or aluminum alloy deemed appropriate by a designer or fabricator (all of which are broadly referred to herein simply as “aluminum”). Various alloys, laminates, and the like may be disposed over (e.g., clad to) the aluminum (the aluminum being exposed to an interior of the body **20**). Additional materials (such as structural materials or electrically insulative materials, such as some polymer-based materials) may be used to complement the body and/or the housing **7**. The materials disposed over the aluminum may likewise be chosen by what is deemed appropriate by a designer or fabricator.

[0243] In some embodiments, the multi-layer material is used for internal components. For example, aluminum may be clad with stainless steel to provide for a multi-layer material in at least one of the terminals **8**. In some of these embodiments, a portion of the aluminum may be removed to expose the stainless steel. The exposed stainless steel may then be used to attach the terminal **8** to the feed-through **19** by use of simple welding procedures.

[0244] Using the clad material for internal components may call for particular embodiments of the clad material. For example, it may be beneficial to use clad material that include aluminum (bottom layer), stainless steel and/or tantalum (intermediate layer) and aluminum (top layer), which thus limits exposure of stainless steel to the internal environment of the ultracapacitor **10**. These embodiments may be augmented by, for example, additional coating with polymeric materials, such as PTFE.

[0245] Accordingly, providing a housing **7** that takes advantage of multi-layered material provides for an energy storage that exhibits leakage current with comparatively low initial values and substantially slower increases in leakage current over time in view of the prior art. Significantly, the

leakage current of the energy storage remains at practical (i.e., desirably low) levels when the ultracapacitor **10** is exposed to ambient temperatures for which prior art capacitors would exhibit prohibitively large initial values of leakage current and/or prohibitively rapid increases in leakage current over time.

[0246] Additionally, the ultracapacitor **10** may exhibit other benefits as a result of reduced reaction between the housing **7** and the energy storage cell **12**. For example, an effective series resistance (ESR) of the energy storage may exhibit comparatively lower values over time. Further, the unwanted chemical reactions that take place in a prior art capacitor often create unwanted effects such as out-gassing, or in the case of a hermetically sealed housing, bulging of the housing **7**. In both cases, this leads to a compromise of the structural integrity of the housing **7** and/or hermetic seal of the energy storage. Ultimately, this may lead to leaks or catastrophic failure of the prior art capacitor. These effects may be substantially reduced or eliminated by the application of a disclosed barrier.

[0247] By use of a multi-layer material (e.g., a clad material), stainless steel may be incorporated into the housing **7**, and thus components with glass-to-metal seals may be used. The components may be welded to the stainless steel side of the clad material using techniques such as laser or resistance welding, while the aluminum side of the clad material may be welded to other aluminum parts (e.g., the body **20**).

[0248] In some embodiments, an insulative polymer may be used to coat parts of the housing **7**. In this manner, it is possible to insure that the components of the energy storage are only exposed to acceptable types of metal (such as the aluminum). Exemplary insulative polymer includes PFA, FEP, TFE, and PTFE. Suitable polymers (or other materials) are limited only by the needs of a system designer or fabricator and the properties of the respective materials. Reference may be had to FIG. **23**, where a small amount of insulative material **39** is included to limit exposure of electrolyte **6** to the stainless steel of the sleeve **51** and the feed-through **19**. In this example, the terminal **8** is coupled to the feed-through **19**, such as by welding, and then coated with the insulative material **39**.

[0249] i. Housing Cap

[0250] Although this example depicts only one feed-through **19** on the cap **24**, it should be recognized that the construction of the housing **7** is not limited by the embodiments discussed herein. For example, the cap **24** may include a plurality of feed-throughs **19**. In some embodiments, the body **20** includes a second, similar cap **24** at an opposing end of the annular cylinder. Further, it should be recognized that the housing **7** is not limited to embodiments having an annular cylindrically shaped body **20**. For example, the housing **7** may be a clamshell design, a prismatic design, a pouch, or of any other design that is appropriate for the needs of the designer, manufacturer or user.

[0251] Referring now to FIG. **18**, aspects of embodiments of a blank **34** for the cap **24** are shown. In FIG. **18A**, the blank **34** includes a multi-layer material. A layer of a first material **41** may be aluminum. A layer of a second material **42** may be stainless steel. In the embodiments of FIG. **18**, the stainless steel is clad onto the aluminum, thus providing for a material that exhibits a desired combination of metallurgical properties. That is, in the embodiments provided

herein, the aluminum is exposed to an interior of the energy storage cell (i.e., the housing), while the stainless steel is exposed to exterior. In this manner, advantageous electrical properties of the aluminum are enjoyed, while structural properties (and metallurgical properties, i.e., weldability) of the stainless steel are relied upon for construction. The multi-layer material may include additional layers as deemed appropriate.

[0252] As mentioned above, the layer of first material **41** is clad onto (or with) the layer of second material **42**. Referring still to FIG. **18A**, in one embodiment, a sheet of flat stock (as shown) is used to provide the blank **34** to create a flat cap **24**. A portion of the layer of second material **42** may be removed (such as around a circumference of the cap **24**) in order to facilitate attachment of the cap **24** to the body **20**. In FIG. **18B**, another embodiment of the blank **34** is shown. In this example, the blank **34** is provided as a sheet of clad material that is formed into a concave configuration. In FIG. **18C**, the blank **34** is provided as a sheet of clad material that is formed into a convex configuration. The cap **24** that is fabricated from the various embodiments of the blank **34** (such as those shown in FIG. **18**), are configured to support welding to the body **20** of the housing **7**. More specifically, the embodiment of FIG. **18B** is adapted for fitting within an inner diameter of the body **20**, while the embodiment of FIG. **18C** is adapted for fitting over an outer diameter of the body **20**. In various alternative embodiments, the layers of clad material within the sheet may be reversed.

[0253] Referring now to FIG. **19**, there is shown an embodiment of an electrode assembly **50**. The electrode assembly **50** is designed to be installed into the blank **34** and to provide electrical communication from the energy storage media to a user. Generally, the electrode assembly **50** includes a sleeve **51**. The sleeve **51** surrounds the insulator **26**, which in turn surrounds the feed-through **19**. In this example, the sleeve **51** is an annular cylinder with a flanged top portion.

[0254] In order to assemble the cap **24**, a perforation (not shown) is made in the blank **34**. The perforation has a geometry that is sized to match the electrode assembly **50**. Accordingly, the electrode assembly **50** is inserted into perforation of the blank **34**. Once the electrode assembly **50** is inserted, the electrode assembly **50** may be affixed to the blank **34** through a technique such as welding. The welding may be laser welding which welds about a circumference of the flange of sleeve **51**. Referring to FIG. **20**, points **61** where welding is performed are shown. In this embodiment, the points **61** provide suitable locations for welding of stainless steel to stainless steel, a relatively simple welding procedure. Accordingly, the teachings herein provide for welding the electrode assembly **50** securely into place on the blank **34**.

[0255] Material for constructing the sleeve **51** may include various types of metals or metal alloys. Generally, materials for the sleeve **51** are selected according to, for example, structural integrity and bondability (to the blank **34**). Exemplary materials for the sleeve **51** include 304 stainless steel or 316 stainless steel. Material for constructing the feed-through **19** may include various types of metals or metal alloys. Generally, materials for the feed-through **19** are selected according to, for example, structural integrity and electrical conductance. Exemplary materials for the electrode include 446 stainless steel or 52 alloy.

[0256] Generally, the insulator **26** is bonded to the sleeve **51** and the feed-through **19** through known techniques (i.e., glass-to-metal bonding). Material for constructing the insulator **26** may include, without limitation, various types of glass, including high temperature glass, ceramic glass or ceramic materials. Generally, materials for the insulator are selected according to, for example, structural integrity and electrical resistance (i.e., electrical insulation properties).

[0257] Use of components (such as the foregoing embodiment of the electrode assembly **50**) that rely on glass-to-metal bonding as well as use of various welding techniques provides for hermetic sealing of the energy storage. Other components may be used to provide hermetic sealing as well. As used herein, the term "hermetic seal" generally refers to a seal that exhibits a leak rate no greater than that which is defined herein. However, it is considered that the actual seal efficacy may perform better than this standard.

[0258] Additional or other techniques for coupling the electrode assembly **50** to the blank **34** include use of a bonding agent under the flange of the sleeve **51** (between the flange and the layer of second material **42**), when such techniques are considered appropriate.

[0259] Referring now to FIG. **21**, the energy storage cell **12** is disposed within the body **20**. The at least one terminal **8** is coupled appropriately (such as to the feed-through **19**), and the cap **24** is mated with the body **20** to provide for the ultracapacitor **10**.

[0260] Once assembled, the cap **24** and the body **20** may be sealed. FIG. **22** depicts various embodiments of the assembled energy storage (in this case, the ultracapacitor **10**). In FIG. **22A**, a flat blank **34** (see FIG. **18A**) is used to create a flat cap **24**. Once the cap **24** is set on the body **20**, the cap **24** and the body **20** are welded to create a seal **62**. In this case, as the body **20** is an annular cylinder, the weld proceeds circumferentially about the body **20** and cap **24** to provide the seal **62**. In a second embodiment, shown in FIG. **22B**, the concave blank **34** (see FIG. **18B**) is used to create a concave cap **24**. Once the cap **24** is set on the body **20**, the cap **24** and the body **20** are welded to create the seal **62**. In a third embodiment, shown in FIG. **22C**, the convex blank **34** (see FIG. **18C**) is used to create a convex cap **24**. Once the cap **24** is set on the body **20**, the cap **24** and the body **20** may be welded to create the seal **62**.

[0261] As appropriate, clad material may be removed (by techniques such as, for example, machining or etching, etc.) to expose other metal in the multi-layer material. Accordingly, in some embodiments, the seal **62** may include an aluminum-to-aluminum weld. The aluminum-to-aluminum weld may be supplemented with other fasteners, as appropriate.

[0262] Other techniques may be used to seal the housing **7**. For example, laser welding, TIG welding, resistance welding, ultrasonic welding, and other forms of mechanical sealing may be used. It should be noted, however, that in general, traditional forms of mechanical sealing alone are not adequate for providing the robust hermetic seal offered in the ultracapacitor **10**.

[0263] Refer now to FIG. **24** in which aspects of assembly another embodiment of the cap **24** are depicted. FIG. **24A** depicts a template (i.e., the blank **34**) that is used to provide a body of the cap **24**. The template is generally sized to mate with the housing **7** of an appropriate type of energy storage cell (such as the ultracapacitor **10**). The cap **24** may be formed by initially providing the template forming the

template, including a dome 37 within the template (shown in FIG. 24B) and by then perforating the dome 37 to provide a through-way 32 (shown in FIG. 24C). Of course, the blank 34 (e.g., a circular piece of stock) may be pressed or otherwise fabricated such that the foregoing features are simultaneously provided.

[0264] In general, and with regard to these embodiments, the cap may be formed of aluminum, or an alloy thereof. However, the cap may be formed of any material that is deemed suitable by a manufacturer, user, designer and the like. For example, the cap 24 may be fabricated from steel and passivated (i.e., coated with an inert coating) or otherwise prepared for use in the housing 7.

[0265] Referring now also to FIG. 25, there is shown another embodiment of the electrode assembly 50. In these embodiments, the electrode assembly 50 includes the feed-through 19 and a hemispherically shaped material disposed about the feed-through 19. The hemispherically shaped material serves as the insulator 26, and is generally shaped to conform to the dome 37. The hemispheric insulator 26 may be fabricated of any suitable material for providing a hermetic seal while withstanding the chemical influence of the electrolyte 6. Exemplary materials include PFA (perfluoroalkoxy polymer), FEP (fluorinated ethylene-propylene), PVF (polyvinylfluoride), TFE (tetrafluoroethylene), CTFE (chlorotrifluoroethylene), PCTFE (polychlorotrifluoroethylene), ETFE (polyethylenetetrafluoroethylene), ECTFE (polyethylenechlorotrifluoroethylene), PTFE (polytetrafluoroethylene), another fluoropolymer based material as well as any other material that may exhibit similar properties (in varying degrees) and provide for satisfactory performance (such as by exhibiting, among other things, a high resistance to solvents, acids, and bases at high temperatures, low cost and the like).

[0266] The feed-through 19 may be formed of aluminum, or an alloy thereof. However, the feed-through 19 may be formed of any material that is deemed suitable by a manufacturer, user, designer and the like. For example, the feed-through 19 may be fabricated from steel and passivated (i.e., coated with an inert coating, such as silicon) or otherwise prepared for use in the electrode assembly 50. An exemplary technique for passivation includes depositing a coating of hydrogenated amorphous silicon on the surface of the substrate and functionalizing the coated substrate by exposing the substrate to a binding reagent having at least one unsaturated hydrocarbon group under pressure and elevated temperature for an effective length of time. The hydrogenated amorphous silicon coating is deposited by exposing the substrate to silicon hydride gas under pressure and elevated temperature for an effective length of time.

[0267] The hemispheric insulator 26 may be sized relative to the dome 37 such that a snug fit (i.e., hermetic seal) is achieved when assembled into the cap 24. The hemispheric insulator 26 need not be perfectly symmetric or of classic hemispheric proportions. That is, the hemispheric insulator 26 is substantially hemispheric, and may include, for example, slight adjustments in proportions, a modest flange (such as at the base) and other features as deemed appropriate. The hemispheric insulator 26 is generally formed of homogeneous material, however, this is not a requirement. For example, the hemispheric insulator 26 may include an air or gas filled torus (not shown) therein to provide for desired expansion or compressibility.

[0268] As shown in FIG. 26, the electrode assembly 50 may be inserted into the template (i.e., the formed blank 34) to provide for an embodiment of the cap 24 that includes a hemispheric hermetic seal.

[0269] As shown in FIG. 27, in various embodiments, a retainer 43 may be bonded or otherwise mated to a bottom of the cap 24 (i.e., a portion of the cap 24 that faces to an interior of the housing 7 and faces the energy storage cell 12). The retainer 43 may be bonded to the cap 24 through various techniques, such as aluminum welding (such as laser, ultrasonic and the like). Other techniques may be used for the bonding, including for example, stamping (i.e., mechanical bonding) and brazing. The bonding may occur, for example, along a perimeter of the retainer 43. Generally, the bonding is provided for in at least one bonding point to create a desired seal 71. At least one fastener, such as a plurality of rivets may be used to seal the insulator 26 within the retainer 43.

[0270] In the example of FIG. 27, the cap 24 is of a concave design (see FIG. 18B). However, other designs may be used. For example, a convex cap 24 may be provided (FIG. 18C), and an over-cap 24 may also be used (a variation of the embodiment of FIG. 18C, which is configured to mount as depicted in FIG. 22C).

[0271] The material used for the cap as well as the feed-through 19 may be selected with regard for thermal expansion of the hemispheric insulator 26. Further, manufacturing techniques may also be devised to account for thermal expansion. For example, when assembling the cap 24, a manufacturer may apply pressure to the hemispheric insulator 26, thus at least somewhat compressing the hemispheric insulator 26. In this manner, there at least some thermal expansion of the cap 24 is provided for without jeopardizing efficacy of the hermetic seal.

[0272] For further clarification of the assembled ultracapacitor, refer to FIG. 28, where a cut-away view of the ultracapacitor 10 is provided. In this example, the storage cell 12 is inserted into and contained within the body 20. Each plurality of leads are bundled together and coupled to the housing 7 as one of the terminals 8. In some embodiments, the plurality of leads are coupled to a bottom of the body 20 (on the interior), thus turning the body 20 into a negative contact 55. Likewise, another plurality of leads are bundled and coupled to the feed-through 19, to provide a positive contact 56. Electrical isolation of the negative contact 55 and the positive contact 56 is preserved by the electrical insulator 26. Generally, coupling of the leads is accomplished through welding, such as at least one of laser and ultrasonic welding. Of course, other techniques may be used as deemed appropriate.

[0273] ii. Inner Barrier

[0274] Referring now to FIG. 13, the housing 7 may include an inner barrier 30. In some embodiments, the barrier 30 is a coating. In this example, the barrier 30 is formed of polytetrafluoroethylene (PTFE). Polytetrafluoroethylene (PTFE) exhibits various properties that make this composition well suited for the barrier 30. PTFE has a melting point of about 327 degrees Celsius, has excellent dielectric properties, has a coefficient of friction of between about 0.05 to 0.10, which is the third-lowest of any known solid material, has a high corrosion resistance and other beneficial properties. Generally, an interior portion of the cap 24 may include the barrier 30 disposed thereon.

[0275] Other materials may be used for the barrier 30. Among these other materials are forms of ceramics (any type of ceramic that may be suitably applied and meet performance criteria), other polymers (preferably, a high temperature polymer) and the like. Exemplary other polymers include perfluoroalkoxy (PFA) and fluorinated ethylene propylene (FEP) as well as ethylene tetrafluoroethylene (ETFE).

[0276] The barrier 30 may include any material or combinations of materials that provide for reductions in electrochemical or other types of reactions between the energy storage cell 12 and the housing 7 or components of the housing 7. In some embodiments, the combinations are manifested as homogeneous dispersions of differing materials within a single layer. In other embodiments, the combinations are manifested as differing materials within a plurality of layers. Other combinations may be used. In short, the barrier 30 may be considered as at least one of an electrical insulator and chemically inert (i.e., exhibiting low reactivity) and therefore substantially resists or impedes at least one of electrical and chemical interactions between the storage cell 12 and the housing 7. In some embodiments, the term “low reactivity” and “low chemical reactivity” generally refer to a rate of chemical interaction that is below a level of concern for an interested party.

[0277] In general, the interior of the housing 7 may be host to the barrier 30 such that all surfaces of the housing 7 which are exposed to the interior are covered. At least one untreated area 31 may be included within the body 20 and on an outer surface 36 of the cap 24 (see FIG. 14A). In some embodiments, untreated areas 31 (see FIG. 14B) may be included to account for assembly requirements, such as areas which will be sealed or connected (such as by welding).

[0278] The barrier 30 may be applied to the interior portions using conventional techniques. For example, in the case of PTFE, the barrier 30 may be applied by painting or spraying the barrier 30 onto the interior surface as a coating. A mask may be used as a part of the process to ensure untreated areas 31 retain desired integrity. In short, a variety of techniques may be used to provide the barrier 30.

[0279] In an exemplary embodiment, the barrier 30 is about 3 mil to about 5 mil thick, while material used for the barrier 30 is a PFA based material. In this example, surfaces for receiving the material that make up the barrier 30 are prepared with grit blasting, such as with aluminum oxide. Once the surfaces are cleaned, the material is applied, first as a liquid then as a powder. The material is cured by a heat treating process. In some embodiments, the heating cycle is about 10 minutes to about 15 minutes in duration, at temperatures of about 370 degrees Celsius. This results in a continuous finish to the barrier 30 that is substantially free of pin-hole sized or smaller defects. FIG. 15 depicts assembly of an embodiment of the ultracapacitor 10 according to the teachings herein. In this embodiment, the ultracapacitor 10 includes the body 20 that includes the barrier 30 disposed therein, a cap 24 with the barrier 30 disposed therein, and the energy storage cell 12. During assembly, the cap 24 is set over the body 20. A first one of the terminals 8 is electrically coupled to the cap feed-through 19, while a second one of the terminals 8 is electrically coupled to the housing 7, typically at the bottom, on the side or on the cap 24. In some embodiments, the second one of the terminals 8 is coupled to another feed-through 19 (such as of an opposing cap 24).

[0280] With the barrier 30 disposed on the interior surface (s) of the housing 7, electrochemical and other reactions between the housing 7 and the electrolyte are greatly reduced or substantially eliminated. This is particularly significant at higher temperatures where a rate of chemical and other reactions is generally increased.

[0281] Referring now to FIG. 16, there is shown relative performance of the ultracapacitor 10 in comparison to an otherwise equivalent ultracapacitor. In FIG. 16A, leakage current is shown for a prior art embodiment of the ultracapacitor 10. In FIG. 16B, leakage current is shown for an equivalent ultracapacitor 10 that includes the barrier 30. In FIG. 16B, the ultracapacitor 10 is electrically equivalent to the ultracapacitor whose leakage current is shown in FIG. 16A. In both cases, the housing 7 was stainless steel, and the voltage supplied to the cell was 1.75 Volts, and electrolyte was not purified. Temperature was held a constant 150 degrees Celsius. Notably, the leakage current in FIG. 16B indicates a comparably lower initial value and no substantial increase over time while the leakage current in FIG. 16A indicates a comparably higher initial value as well as a substantial increase over time.

[0282] Generally, the barrier 30 provides a suitable thickness of suitable materials between the energy storage cell 12 and the housing 7. The barrier 30 may include a homogeneous mixture, a heterogeneous mixture and/or at least one layer of materials. The barrier 30 may provide complete coverage (i.e., provide coverage over the interior surface area of the housing with the exception of electrode contacts) or partial coverage. In some embodiments, the barrier 30 is formed of multiple components. Consider, for example, the embodiment presented below and illustrated in FIG. 8.

[0283] Referring to FIG. 17, aspects of an additional embodiment are shown. In some embodiments, the energy storage cell 12 is deposited within an envelope 73. That is, the energy storage cell 12 has the barrier 30 disposed thereon, wrapped thereover, or otherwise applied to separate the energy storage cell 12 from the housing 7 once assembled. The envelope 73 may be applied well ahead of packaging the energy storage cell 12 into the housing 7. Therefore, use of an envelope 73 may present certain advantages, such as to manufacturers. (Note that the envelope 73 is shown as loosely disposed over the energy storage cell 12 for purposes of illustration).

[0284] In some embodiments, the envelope 73 is used in conjunction with the coating, wherein the coating is disposed over at least a portion of the interior surfaces. For example, in one embodiment, the coating is disposed within the interior of the housing 7 only in areas where the envelope 73 may be at least partially compromised (such as be a protruding terminal 8). Together, the envelope 73 and the coating form an efficient barrier 30.

[0285] Accordingly, incorporation of the barrier 30 may provide for an ultracapacitor that exhibits leakage current with comparatively low initial values and substantially slower increases in leakage current over time in view of the prior art. Significantly, the leakage current of the ultracapacitor remains at practical (i.e., desirably low) levels when the ultracapacitor is exposed to ambient temperatures for which prior art capacitors would exhibit prohibitively large initial values of leakage current and/or prohibitively rapid increases in leakage current over time.

[0286] Having thus described embodiments of the barrier 30, and various aspects thereof, it should be recognized the

ultracapacitor **10** may exhibit other benefits as a result of reduced reaction between the housing **7** and the energy storage media **1**. For example, an effective series resistance (ESR) of the ultracapacitor **10** may exhibit comparatively lower values over time. Further, unwanted chemical reactions that take place in a prior art capacitor often create unwanted effects such as out-gassing, or in the case of a hermetically sealed housing, bulging of the housing. In both cases, this leads to a compromise of the structural integrity of the housing and/or hermetic seal of the capacitor. Ultimately, this may lead to leaks or catastrophic failure of the prior art capacitor. In some embodiments, these effects may be substantially reduced or eliminated by the application of a disclosed barrier **30**.

[0287] It should be recognized that the terms “barrier” and “coating” are not limiting of the teachings herein. That is, any technique for applying the appropriate material to the interior of the housing **7**, body **20** and/or cap **24** may be used. For example, in other embodiments, the barrier **30** is actually fabricated into or onto material making up the housing body **20**, the material then being worked or shaped as appropriate to form the various components of the housing **7**. When considering some of the many possible techniques for applying the barrier **30**, it may be equally appropriate to roll on, sputter, sinter, laminate, print, or otherwise apply the material(s). In short, the barrier **30** may be applied using any technique deemed appropriate by a manufacturer, designer and/or user.

[0288] Materials used in the barrier **30** may be selected according to properties such as reactivity, dielectric value, melting point, adhesion to materials of the housing **7**, coefficient of friction, cost, and other such factors. Combinations of materials (such as layered, mixed, or otherwise combined) may be used to provide for desired properties.

[0289] Using an enhanced housing **7**, such as one with the barrier **30**, may, in some embodiments, limit degradation of the advanced electrolyte system. While the barrier **30** presents one technique for providing an enhanced housing **7**, other techniques may be used. For example, use of a housing **7** fabricated from aluminum would be advantageous, due to the electrochemical properties of aluminum in the presence of electrolyte **6**. However, given the difficulties in fabrication of aluminum, it has not been possible (until now) to construct embodiments of the housing **7** that take advantage of aluminum.

[0290] Additional embodiments of the housing **7** include those that present aluminum to all interior surfaces, which may be exposed to electrolyte, while providing users with an ability to weld and hermetically seal the housing. Improved performance of the ultracapacitor **10** may be realized through reduced internal corrosion, elimination of problems associated with use of dissimilar metals in a conductive media and for other reasons. Advantageously, the housing **7** makes use of existing technology, such available electrode inserts that include glass-to-metal seals (and may include those fabricated from stainless steel, tantalum or other advantageous materials and components), and therefore is economic to fabricate.

[0291] Although disclosed herein as embodiments of the housing **7** that are suited for the ultracapacitor **10**, these embodiments (as is the case with the barrier **30**) may be used with any type of energy storage deemed appropriate, and may include any type of technology practicable. For

example, other forms of energy storage may be used, including electrochemical batteries, in particular, lithium based batteries.

[0292] In general, the material(s) exposed to an interior of the housing **7** exhibit adequately low reactivity when exposed to the electrolyte **6**, i.e., the advanced electrolyte system of the present invention, and therefore are merely illustrative of some of the embodiments and are not limiting of the teachings herein.

[0293] F. Factors for General Construction of Capacitors

[0294] An important aspect for consideration in construction of the ultracapacitor **10** is maintaining good chemical hygiene. In order to assure purity of the components, in various embodiments, the activated carbon, carbon fibers, rayon, carbon cloth, and/or nanotubes making up the energy storage media **1** for the two electrodes **3**, are dried at elevated temperature in a vacuum environment. The separator **5** is also dried at elevated temperature in a vacuum environment. Once the electrodes **3** and the separator **5** are dried under vacuum, they are packaged in the housing **7** without a final seal or cap in an atmosphere with less than 50 parts per million (ppm) of water. The uncapped ultracapacitor **10** may be dried, for example, under vacuum over a temperature range of about 100 degrees Celsius to about 300 degrees Celsius. Once this final drying is complete, the electrolyte **6** may be added and the housing **7** is sealed in a relatively dry atmosphere (such as an atmosphere with less than about 50 ppm of moisture). Of course, other methods of assembly may be used, and the foregoing provides merely a few exemplary aspects of assembly of the ultracapacitor **10**.

III. Methods of the Invention

[0295] Certain methods of the invention useful for reducing impurities or fabricating devices of the present invention are described herein below. Such methods of purification are also additionally applicable to any advanced electrolyte system of the present invention

[0296] A. Methods of Reduction of Impurities

[0297] i. AES Contaminants

[0298] In certain embodiments, the advanced electrolyte system (AES) of the present invention is purified remove contaminants and to provide desired enhanced performance characteristics described herein. As such, the present disclosure provides a method for purifying an AES, the method comprising: mixing water into an advanced electrolyte system to provide a first mixture; partitioning the first mixture; collecting the advanced electrolyte system from the first mixture; adding a solvent to the collected liquid to provide a second mixture; mixing carbon into the second mixture to provide a third mixture; separating the advanced electrolyte system from the third mixture to obtain the purified advanced electrolyte system. Generally, the process calls for selecting an electrolyte, adding de-ionized water as well as activated carbon under controlled conditions. The de-ionized water and activated carbon are subsequently removed, resulting in an electrolyte that is substantially purified. The purified electrolyte is suited for use in, among other things, an ultracapacitor.

[0299] This method may be used to ensure a high degree of purity of the advanced electrolyte system (AES) of the present invention. It should be noted that although the process is presented in terms of specific parameters (such as quantities, formulations, times and the like), that the pre-

sentation is merely exemplary and illustrative of the process for purifying electrolyte and is not limiting thereof.

[0300] For example, the method may further comprise one or more of the following steps or characterizations: heating the first mixture; wherein partitioning comprises letting the first mixture sit undisturbed until the water and the AES are substantially partitioned; wherein adding a solvent comprises adding at least one of diethylether, pentone, cyclopentone, hexane, cyclohexane, benzene, toluene, 1-4 dioxane, and chloroform; wherein mixing carbon comprises mixing carbon powder; wherein mixing carbon comprises stirring the third mixture substantially constantly; wherein separating the AES comprises at least one of filtering carbon from the third mixture and evaporating the solvent from the third mixture.

[0301] In a first step of the process for purifying electrolyte, the electrolyte **6** (in some embodiments, the ionic liquid) is mixed with deionized water, and then raised to a moderate temperature for some period of time. In a proof of concept, fifty (50) milliliters (ml) of ionic liquid was mixed with eight hundred and fifty (850) milliliters (ml) of the deionized water. The mixture was raised to a constant temperature of sixty (60) degrees Celsius for about twelve (12) hours and subjected to constant stirring (of about one hundred and twenty (120) revolutions per minute (rpm)).

[0302] In a second step, the mixture of ionic liquid and deionized water is permitted to partition. In this example, the mixture was transferred via a funnel, and allowed to sit for about four (4) hours.

[0303] In a third step, the ionic liquid is collected. In this example, a water phase of the mixture resided on the bottom, with an ionic liquid phase on the top. The ionic liquid phase was transferred into another beaker.

[0304] In a fourth step, a solvent was mixed with the ionic liquid. In this example, a volume of about twenty five (25) milliliters (ml) of ethyl acetate was mixed with the ionic liquid. This mixture was again raised to a moderate temperature and stirred for some time.

[0305] Although ethyl acetate was used as the solvent, the solvent can be at least one of diethylether, pentone, cyclopentone, hexane, cyclohexane, benzene, toluene, 1-4 dioxane, chloroform or any combination thereof as well as other material(s) that exhibit appropriate performance characteristics. Some of the desired performance characteristics include those of a non-polar solvent as well as a high degree of volatility.

[0306] In a fifth step, carbon powder is added to the mixture of the ionic liquid and solvent. In this example, about twenty (20) weight percent (wt %) of carbon (of about a 0.45 micrometer diameter) was added to the mixture.

[0307] In a sixth step, the ionic liquid is again mixed. In this example, the mixture with the carbon powder was then subjected to constant stirring (120 rpm) overnight at about seventy (70) degrees Celsius.

[0308] In a seventh step, the carbon and the ethyl acetate are separated from the ionic liquid. In this example, the carbon was separated using Buchner filtration with a glass microfiber filter. Multiple filtrations (three) were performed. The ionic liquid collected was then passed through a 0.2 micrometer syringe filter in order to remove substantially all of the carbon particles. In this example, the solvent was then subsequently separated from the ionic liquid by employing rotary evaporation. Specifically, the sample of ionic liquid was stirred while increasing temperature from seventy (70)

degrees Celsius to eighty (80) degrees Celsius, and finished at one hundred (100) degrees Celsius. Evaporation was performed for about fifteen (15) minutes at each of the respective temperatures.

[0309] The process for purifying electrolyte has proven to be very effective. For the sample ionic liquid, water content was measured by titration, with a titration instrument provided by Mettler-Toledo Inc., of Columbus, Ohio (model No: AQC22). Halide content was measured with an ISE instrument provided by Hanna Instruments of Woonsocket, R.I. (model no. AQC22). The standards solution for the ISE instrument was obtained from Hanna, and included HI 4007-03 (1,000 ppm chloride standard), HI 4010-03 (1,000 ppm fluoride standard) HI 4000-00 (ISA for halide electrodes), and HI 4010-00 (TISAB solution for fluoride electrode only). Prior to performing measurements, the ISE instrument was calibrated with the standards solutions using 0.1, 10, 100 and 1,000 parts per million (ppm) of the standards, mixed in with deionized water. ISA buffer was added to the standard in a 1:50 ratio for measurement of Cl⁻ ions. Results are shown in Table 3.

TABLE 3

Purification Data for Electrolyte Containing 1-butyl-1-methylpyrrolidinium and tetracyanoborate			
Impurity	Before (ppm)	After (ppm)	DI Water (ppm)
Cl ⁻	5,300.90	769	9.23E-1
F ⁻	75.61	10.61	1.10E-1
H ₂ O	1080	20	—

[0310] A four step process was used to measure the halide ions. First, Cl⁻ and F⁻ ions were measured in the deionized water. Next, a 0.01 M solution of ionic liquid was prepared with deionized water. Subsequently, Cl⁻ and F⁻ ions were measured in the solution. Estimation of the halide content was then determined by subtracting the quantity of ions in the water from the quantity of ions in the solution.

[0311] Purification standards were also examined with respect to the electrolyte contaminant compositions through the analysis of leakage current. FIG. 9 depicts leakage current for unpurified electrolyte in the ultracapacitor **10**. FIG. 10 depicts leakage current for purified electrolyte in a similarly structured ultracapacitor **10**. As one can see, there is a substantial decrease in initial leakage current, as well as a modest decrease in leakage current over the later portion of the measurement interval. More information is provided on the construction of each embodiment in Table 4.

TABLE 4

Test Ultracapacitor Configuration		
Parameter	FIG. 9	FIG. 10
Cell Size:	Open Sub C	Open Sub C
Casing:	Coated P870	Coated P870
Electrode Material:	Double Sided Activated Carbon(150/40)	Double Sided Activated Carbon(150/40)
Separator:	Fiberglass	Fiberglass
Size of Electrodes:	IE: 233 × 34 mm OE: 256 × 34 mm	IE: 233 × 34 mm OE: 256 × 34 mm
Electrodes:	0.005" Aluminum (3 Tabs)	0.005" Aluminum (3 Tabs)

TABLE 4-continued

Test Ultracapacitor Configuration		
Parameter	FIG. 9	FIG. 10
Temperature	150° C.	150° C.
Electrolyte:	Unpurified AES	Purified AES

[0312] Other benefits are also realized, including improvements in stability of resistance and capacitance of the ultracapacitor **10**.

[0313] Leakage current may be determined in a number of ways. Qualitatively, leakage current may be considered as current drawn into a device, once the device has reached a state of equilibrium. In practice, it is always or almost always necessary to estimate the actual leakage current as a state of equilibrium that may generally only be asymptotically approached. Thus, the leakage current in a given measurement may be approximated by measuring the current drawn into the ultracapacitor **10**, while the ultracapacitor **10** is held at a substantially fixed voltage and exposed to a substantially fixed ambient temperature for a relatively long period of time. In some instances, a relatively long period of time may be determined by approximating the current time function as an exponential function, then allowing for several (e.g., about 3 to 5) characteristic time constants to pass. Often, such a duration ranges from about 50 hours to about 100 hours for many ultracapacitor technologies. Alternatively, if such a long period of time is impractical for any reason, the leakage current may simply be extrapolated, again, perhaps, by approximating the current time function as an exponential or any approximating function deemed appropriate. Notably, leakage current will generally depend on ambient temperature. So, in order to characterize performance of a device at a temperature or in a temperature range, it is generally important to expose the device to the ambient temperature of interest when measuring leakage current.

[0314] Note that one approach to reduce the volumetric leakage current at a specific temperature is to reduce the operating voltage at that temperature. Another approach to reduce the volumetric leakage current at a specific temperature is to increase the void volume of the ultracapacitor. Yet another approach to reduce the leakage current is to reduce loading of the energy storage media **1** on the electrode **3**.

[0315] Having disclosed aspects of embodiments for purification of electrolyte and ionic liquid, it should be recognized that a variety of embodiments may be realized. Further a variety of techniques may be practiced. For example, steps may be adjusted, the order of steps and the like.

[0316] ii. Water/Moisture Content and Removal

[0317] The housing **7** of a sealed ultracapacitor **10** may be opened, and the storage cell **12** sampled for impurities. Water content may be measured using the Karl Fischer method for the electrodes, separator and electrolyte from the cell **12**. Three measurements may be taken and averaged.

[0318] In general, a method for characterizing a contaminant within the ultracapacitor includes breaching the housing **7** to access contents thereof, sampling the contents and analyzing the sample. Techniques disclosed elsewhere herein may be used in support of the characterizing.

[0319] Note that to ensure accurate measurement of impurities in the ultracapacitor and components thereof, including the electrode, the electrolyte and the separator, assembly

and disassembly may be performed in an appropriate environment, such as in an inert environment within a glove box.

[0320] By reducing the moisture content in the ultracapacitor **10** (e.g., to less than 500 part per million (ppm) over the weight and volume of the electrolyte and the impurities to less than 1,000 ppm), the ultracapacitor **10** can more efficiently operate over the temperature range, with a leakage current (I/L) that is less than 10 Amperes per Liter within that temperature range and voltage range.

[0321] In one embodiment, leakage current (I/L) at a specific temperature is measured by holding the voltage of the ultracapacitor **10** constant at the rated voltage (i.e., the maximum rated operating voltage) for seventy two (72) hours. During this period, the temperature remains relatively constant at the specified temperature. At the end of the measurement interval, the leakage current of the ultracapacitor **10** is measured.

[0322] In some embodiments, a maximum voltage rating of the ultracapacitor **10** is about 4 V at room temperature. An approach to ensure performance of the ultracapacitor **10** at elevated temperatures (for example, over 210 degrees Celsius), is to derate (i.e., to reduce) the voltage rating of the ultracapacitor **10**. For example, the voltage rating may be adjusted down to about 0.5 V, such that extended durations of operation at higher temperature are achievable.

[0323] B. Methods of Fabrication of Ultracapacitors

[0324] In another embodiment, the present invention provides a method for fabricating an ultracapacitor comprising the steps of: disposing an energy storage cell comprising energy storage media within a housing; and filling the housing with an advanced electrolyte system (AES), such that an ultracapacitor is fabricated to operate within a temperature range between about -40 degrees Celsius to about 210 degrees Celsius.

[0325] In one particular embodiment, the AES comprises a novel electrolyte entity (NEE), e.g., wherein the NEE is adapted for use in high temperature ultracapacitors. In certain embodiments, the ultracapacitor is configured to operate at a temperature within a temperature range between about 80 degrees Celsius to about 210 degrees Celsius, e.g., a temperature range between about 80 degrees Celsius to about 150 degrees Celsius.

[0326] In one particular embodiment, the AES comprises a highly purified electrolyte, e.g., wherein the highly purified electrolyte is adapted for use in high temperature ultracapacitors. In certain embodiments, the ultracapacitor is configured to operate at a temperature within a temperature range between about 80 degrees Celsius to about 210 degrees Celsius, e.g., a temperature range between about 80 degrees Celsius to about 150 degrees Celsius.

[0327] In one particular embodiment, the AES comprises an enhanced electrolyte combination, e.g., wherein the enhanced electrolyte combination is adapted for use in both high and low temperature ultracapacitors. In certain embodiments, the ultracapacitor is configured to operate at a temperature within a temperature range between about -40 degrees Celsius to about 150 degrees Celsius, e.g., a temperature range between about -30 degrees Celsius to about 125 degrees Celsius.

[0328] In one embodiment, the ultracapacitor fabricated is an ultracapacitor described in Section II, herein above. As such, and as noted above, the advantages over the existing electrolytes of known energy storage devices are selected from one or more of the following improvements: decreased

total resistance, increased long-term stability of resistance, increased total capacitance, increased long-term stability of capacitance, increased energy density, increased voltage stability, reduced vapor pressure, wider temperature range performance for an individual capacitor, increased temperature durability for an individual capacitor; increased ease of manufacturability, and improved cost effectiveness.

[0329] In certain embodiments, the disposing further comprises pre-treating components of the ultracapacitor comprising at least one of: an electrode, a separator, a lead, an assembled energy storage cell and the housing to reduce moisture therein. In particular embodiments, the pre-treating comprises heating the selected components substantially under vacuum over a temperature range of about 100 degrees Celsius to about 150 degrees Celsius. The pre-treating may comprise heating the selected components substantially under vacuum over a temperature range of about 150 degrees Celsius to about 300 degrees Celsius.

[0330] In certain embodiments, the disposing is performed in a substantially inert environment.

[0331] In certain embodiments, the constructing comprises selecting an interior facing material for the housing that exhibits low chemical reactivity with an electrolyte, which may further comprise including the interior facing material in substantial portions of the interior of the housing. The interior facing material may be selected from at least one of aluminum, polytetrafluoroethylene (PTFE), perfluoroalkoxy (PFA), fluorinated ethylene propylene (FEP), ethylene tetrafluoroethylene (ETFE), and a ceramic material as the interior facing material.

[0332] In certain embodiments, the constructing comprises forming the housing from a multilayer material, e.g., wherein forming the housing from a multilayer material comprises disposing a weldable material on an exterior of the housing.

[0333] In certain embodiments, the constructing comprises fabricating at least one of a cap and a body for the housing. The fabricating may comprise disposing a seal comprising an insulator and an electrode insulated from the housing into the housing. Furthermore, disposing the seal may comprise disposing a glass-to-metal seal, e.g., welding the glass-to-metal seal to an outer surface of the housing. In particular embodiments, disposing the seal comprises disposing a hemispheric seal.

[0334] In certain embodiments, the constructing comprises disposing a fill port in the housing to provide for the filling.

[0335] In certain embodiments, the method of fabricating may further comprise fabricating the energy storage cell, e.g., obtaining an electrode by joining energy storage media with a current collector, e.g., joining at least one lead to an electrode. In certain embodiments, the joining at least one lead to the electrode comprises placing at least one reference mark onto the electrode. In certain embodiments, the joining at least one lead to the electrode comprises locating each lead at a respective reference mark. In certain embodiments, the joining at least one lead comprises clearing energy storage media from the current collector. In certain embodiments, the joining at least one lead comprises ultrasonic welding the lead to the current collector.

[0336] The electrode may also be obtained by joining a plurality of electrode elements fabricated from joining energy storage media with a current collector. The plurality of electrode elements may be joined by ultrasonically weld-

ing a joining element to the current collector of one electrode element and to the current collector of another electrode element.

[0337] In certain embodiments, fabricating the energy storage cell comprises disposing a separator between at least two electrodes. And may further comprise aligning each of the electrodes with the separator.

[0338] In certain embodiments, fabricating the energy storage cell comprises packing at least two electrodes with a separator disposed therebetween, e.g., wherein the packing comprises rolling the storage cell into a rolled storage cell.

[0339] In certain embodiments, fabricating the energy storage cell comprises disposing a wrapper over the storage cell.

[0340] In certain embodiments, disposing the energy storage cell comprises grouping a plurality of leads together to provide a terminal, e.g., wherein grouping the plurality of leads together comprises aligning the leads together into a set of aligned leads to form a terminal. In a particular embodiment, the method further comprises, placing a wrapper about the set of aligned leads, placing a fold in the set of aligned leads, or coupling the set of aligned leads to a contact of the housing. Moreover, the coupling may comprise welding the set of aligned leads to the contact, or welding the set of aligned leads to one of a jumper and a bridge for coupling to a contact of the housing.

[0341] In certain embodiments, the method of fabricating may further comprise electrically coupling at least one of a jumper and a bridge to a contact of the housing. In a particular embodiment, this may further comprise substantially disposing an insulative material over the contact on the interior of the housing.

[0342] In certain embodiments, the method of fabricating may further comprise hermitically sealing the energy storage cell within the housing, e.g., wherein hermitically sealing comprises at least one of pulse welding, laser welding, resistance welding and TIG welding components of the housing together.

[0343] In certain embodiments, the method of fabricating may further comprise mating at least one cap with a body to provide the housing, e.g., wherein the cap comprises one of a concave cap, a convex cap and a flat cap. In a particular embodiment, the method may further comprise removing at least a portion of a multilayer material in the housing to provide for the mating.

[0344] In certain embodiments, the method of fabricating may further comprise purifying the AES.

[0345] In certain embodiments, the method of fabricating further comprising disposing a fill port in the housing to provide for the filling, e.g., wherein the filling comprises disposing the AES over a fill port in the housing. In particular embodiments, the method further comprises sealing the fill port upon completion of the filling, e.g., fitting a compatible material into the fill port. Such material may then, in another step, be welded to the housing.

[0346] In certain embodiments, the step of filling comprises drawing a vacuum on the fill port in the housing, e.g., wherein the vacuum is below about 150 mTorr, e.g., wherein the vacuum is below about 40 mTorr.

[0347] In certain embodiments, the step of filling is performed in a substantially inert environment.

[0348] i. Fabrication Techniques

[0349] Moreover, it should be recognized that certain robust assembly techniques may be required to provide

highly efficient energy storage. Accordingly, some of the techniques for assembly are now discussed.

[0350] Once the ultracapacitor **10** is fabricated, it may be used in high temperature applications with little or no leakage current and little increase in resistance. The ultracapacitor **10** described herein can operate efficiently at temperatures from about minus 40 degrees Celsius to about 210 degrees Celsius with leakage currents normalized over the volume of the device less than 10 amperes per liter (A/L) of volume of the device within the entire operating voltage and temperature range. In certain embodiments, the capacitor is operable across temperatures from minus 40 degrees Celsius to 210 degrees Celsius.

[0351] As an overview, a method of assembly of a cylindrically shaped ultracapacitor **10** is provided. Beginning with the electrodes **3**, each electrode **3** is fabricated once the energy storage media **1** has been associated with the current collector **2**. A plurality of leads are then coupled to each electrode **3** at appropriate locations. A plurality of electrodes **3** are then oriented and assembled with an appropriate number of separators **5** therebetween to form the storage cell **12**. The storage cell **12** may then be rolled into a cylinder, and may be secured with a wrapper. Generally, respective ones of the leads are then bundled to form each of the terminals **8**.

[0352] Prior to incorporation of the electrolyte **6**, i.e., the advanced electrolyte systems of the present invention, into the ultracapacitor **10** (such as prior to assembly of the storage cell **12**, or thereafter) each component of the ultracapacitor **10** may be dried to remove moisture. This may be performed with unassembled components (i.e., an empty housing **7**, as well as each of the electrodes **3** and each of the separators **5**), and subsequently with assembled components (such as the storage cell **12**).

[0353] Drying may be performed, for example, at an elevated temperature in a vacuum environment. Once drying has been performed, the storage cell **12** may then be packaged in the housing **7** without a final seal or cap. In some embodiments, the packaging is performed in an atmosphere with less than 50 parts per million (ppm) of water. The uncapped ultracapacitor **10** may then be dried again. For example, the ultracapacitor **10** may be dried under vacuum over a temperature range of about 100 degrees Celsius to about 300 degrees Celsius. Once this final drying is complete, the housing **7** may then be sealed in, for example, an atmosphere with less than 50 ppm of moisture.

[0354] In some embodiments, once the drying process (which may also be referred to a “baking” process) has been completed, the environment surrounding the components may be filled with an inert gas. Exemplary gasses include argon, nitrogen, helium, and other gasses exhibiting similar properties (as well as combinations thereof).

[0355] Generally, a fill port (a perforation in a surface of the housing **7**) is included in the housing **7**, or may be later added. Once the ultracapacitor **10** has been filled with electrolyte **6**, i.e., the advanced electrolyte systems of the present invention, the fill port may then be closed. Closing the fill port may be completed, for example, by welding material (e.g., a metal that is compatible with the housing **7**) into or over the fill port. In some embodiments, the fill port may be temporarily closed prior to filling, such that the ultracapacitor **10** may be moved to another environment, for subsequent re-opening, filling and closure. However, as

discussed herein, it is considered that the ultracapacitor **10** is dried and filled in the same environment.

[0356] A number of methods may be used to fill the housing **7** with a desired quantity of the advanced electrolyte system. Generally, controlling the fill process may provide for, among other things, increases in capacitance, reductions in equivalent-series-resistance (ESR), and limiting waste of electrolyte. A vacuum filling method is provided as a non-limiting example of a technique for filling the housing **7** and wetting the storage cell **12** with the electrolyte **6**.

[0357] First, however, note that measures may be taken to ensure that any material that has a potential to contaminate components of the ultracapacitor **10** is clean, compatible and dry. As a matter of convention, it may be considered that “good hygiene” is practiced to ensure assembly processes and components do not introduce contaminants into the ultracapacitor **10**.

[0358] In the “vacuum method” a container is placed onto the housing **7** around the fill port. A quantity of electrolyte **6**, i.e., the advanced electrolyte systems of the present invention, is then placed into the container in an environment that is substantially free of oxygen and water (i.e., moisture). A vacuum is then drawn in the environment, thus pulling any air out of the housing and thus simultaneously drawing the electrolyte **6** into the housing **7**. The surrounding environment may then be refilled with inert gas (such as argon, nitrogen, or the like, or some combination of inert gases), if desired. The ultracapacitor **10** may be checked to see if the desired amount of electrolyte **6** has been drawn in. The process may be repeated as necessary until the desired amount of electrolyte **6** is in the ultracapacitor **10**.

[0359] After filling with electrolyte **6**, i.e., the advanced electrolyte systems of the present invention, in certain embodiments, material may be fit into the fill port to seal the ultracapacitor **10**. The material may be, for example, a metal that is compatible with the housing **7** and the electrolyte **6**. In one example, material is force fit into the fill port, essentially performing a “cold weld” of a plug in the fill port. In particular embodiments, the force fit may be complimented with other welding techniques as discussed further herein.

[0360] In general, assembly of the housing often involves placing the storage cell **12** within the body **20** and filling the body **20** with the advanced electrolyte system. Another drying process may be performed. Exemplary drying includes heating the body **20** with the storage cell **12** and advanced electrolyte system therein, often under a reduced pressure (e.g., a vacuum). Once adequate (optional) drying has been performed, final steps of assembly may be performed. In the final steps, internal electrical connections are made, the cap **24** is installed, and the cap **24** is hermetically sealed to the body **20**, by, for example, welding the cap **24** to the body **20**.

[0361] In some embodiments, at least one of the housing **7** and the cap **24** is fabricated to include materials that include a plurality of layers. For example, a first layer of material may include aluminum, with a second layer of material being stainless steel. In this example, the stainless steel is clad onto the aluminum, thus providing for a material that exhibits a desired combination of metallurgical properties. That is, in the embodiments provided herein, the aluminum is exposed to an interior of the energy storage cell (i.e., the housing), while the stainless steel is exposed to exterior. In this manner, advantageous electrical properties

of the aluminum are enjoyed, while structural properties (and metallurgical properties, i.e., weldability) of the stainless steel are relied upon for construction. The multi-layer material may include additional layers as deemed appropriate. Advantageously, this provides for welding of stainless steel to stainless steel, a relatively simple welding procedure.

[0362] While material used for construction of the body **20** includes aluminum, any type of aluminum or aluminum alloy deemed appropriate by a designer or fabricator (all of which are broadly referred to herein simply as “aluminum”). Various alloys, laminates, and the like may be disposed over (e.g., clad to) the aluminum (the aluminum being exposed to an interior of the body **20**). Additional materials (such as structural materials or electrically insulative materials, such as some polymer-based materials) may be used to complement the body and/or the housing **7**. The materials disposed over the aluminum may likewise be chosen by what is deemed appropriate by a designer or fabricator.

[0363] Use of aluminum is not necessary or required. In short, material selection may provide for use of any material deemed appropriate by a designer, fabricator, or user and the like. Considerations may be given to various factors, such as, for example, reduction of electrochemical interaction with the electrolyte **6**, structural properties, cost and the like.

[0364] Embodiments of the ultracapacitor **10** that exhibit a relatively small volume may be fabricated in a prismatic form factor such that the electrodes **3** of the ultracapacitor **10** oppose one another, at least one electrode **3** having an internal contact to a glass to metal seal, the other having an internal contact to a housing or to a glass to metal seal.

[0365] A volume of a particular ultracapacitor **10** may be extended by combining several storage cells (e.g., welding together several jelly rolls) within one housing **7** such that they are electrically in parallel or in series.

[0366] In a variety of embodiments, it is useful to use a plurality of the ultracapacitors **10** together to provide a power supply. In order to provide for reliable operation, individual ultracapacitors **10** may be tested in advance of use. In order to perform various types of testing, each of the ultracapacitors **10** may be tested as a singular cell, in series or in parallel with multiple ultracapacitors **10** attached. Using different metals joined by various techniques (such as by welding) can reduce the ESR of the connection as well as increase the strength of the connections. Some aspects of connections between ultracapacitors **10** are now introduced.

[0367] In some embodiments, the ultracapacitor **10** includes two contacts. The two contacts are the glass-to-metal seal pin (i.e., the feed-through **19**) and the entire rest of the housing **7**. When connecting a plurality of the ultracapacitors **10** in series, it is often desired to couple an interconnection between a bottom of the housing **7** (in the case of the cylindrical form housing **7**), such that distance to the internal leads is minimized, and therefore of a minimal resistance. In these embodiments, an opposing end of the interconnection is usually coupled to the pin of the glass-to-metal seal.

[0368] With regard to interconnections, a common type of weld involves use of a parallel tip electric resistance welder. The weld may be made by aligning an end of the interconnection above the pin and welding the interconnection directly to the pin. Using a number of welds will increase the strength and connection between the interconnection and the pin. Generally, when welding to the pin, configuring a shape

of the end of the interconnection to mate well with the pin serves to ensure there is substantially no excess material overlapping the pin that would cause a short circuit.

[0369] An opposed tip electric resistance welder may be used to weld the interconnection to the pin, while an ultrasonic welder may be used to weld the interconnection to the bottom of the housing **7**. Soldering techniques may be used when metals involved are compatible.

[0370] With regard to materials used in interconnections, a common type of material used for the interconnection is nickel. Nickel may be used as it welds well with stainless steel and has a strong interface. Other metals and alloys may be used in place of nickel, for example, to reduce resistance in the interconnection.

[0371] Generally, material selected for the interconnection is chosen for compatibility with materials in the pin as well as materials in the housing **7**. Exemplary materials include copper, nickel, tantalum, aluminum, and nickel copper clad. Further metals that may be used include silver, gold, brass, platinum, and tin.

[0372] In some embodiments, such as where the pin (i.e., the feed-through **19**) is made of tantalum, the interconnection may make use of intermediate metals, such as by employing a short bridge connection. An exemplary bridge connection includes a strip of tantalum, which has been modified by use of the opposed tip resistance welder to weld a strip of aluminum/copper/nickel to the bridge. A parallel resistance welder is then used to weld the tantalum strip to the tantalum pin.

[0373] The bridge may also be used on the contact that is the housing **7**. For example, a piece of nickel may be resistance welded to the bottom of the housing **7**. A strip of copper may then be ultrasonic welded to the nickel bridge. This technique helps to decrease resistance of cell interconnections. Using different metals for each connection can reduce the ESR of the interconnections between cells in series.

[0374] Having thus described aspects of a robust ultracapacitor **10** that is useful for high temperature environments (i.e., up to about 210 degrees Celsius), some additional aspects are now provided and/or defined.

[0375] A variety of materials may be used in construction of the ultracapacitor **10**. Integrity of the ultracapacitor **10** is essential if oxygen and moisture are to be excluded and the electrolyte **6** is to be prevented from escaping. To accomplish this, seam welds and any other sealing points should meet standards for hermeticity over the intended temperature range for operation. Also, materials selected should be compatible with other materials, such as ionic liquids and solvents that may be used in the formulation of the advanced electrolyte system.

[0376] In some embodiments, the feed-through **19** is formed of metal such as at least one of KOVAR™ (a trademark of Carpenter Technology Corporation of Reading, Pa., where KOVAR is a vacuum melted, iron-nickel-cobalt, low expansion alloy whose chemical composition is controlled within narrow limits to assure precise uniform thermal expansion properties), Alloy 52 (a nickel iron alloy suitable for glass and ceramic sealing to metal), tantalum, molybdenum, niobium, tungsten, Stainless Steel 446 (a ferritic, non-heat treatable stainless steel that offers good resistance to high temperature corrosion and oxidation) and titanium.

[0377] The body of glass-to-metal seals that take advantage of the foregoing may be fabricated from 300 series stainless steels, such as 304, 304L, 316, and 316L alloys. The bodies may also be made from metal such as at least one of various nickel alloys, such as Inconel (a family of austenitic nickel-chromium-based superalloys that are oxidation and corrosion resistant materials well suited for service in extreme environments subjected to pressure and heat) and Hastelloy (a highly corrosion resistant metal alloy that includes nickel and varying percentages of molybdenum, chromium, cobalt, iron, copper, manganese, titanium, zirconium, aluminum, carbon, and tungsten).

[0378] The insulating material between the feed-through **19** and the surrounding body in the glass-to-metal seal is typically a glass, the composition of which is proprietary to each manufacturer of seals and depends on whether the seal is under compression or is matched. Other insulative materials may be used in the glass-to-metal seal. For example, various polymers may be used in the seal. As such, the term “glass-to-metal” seal is merely descriptive of a type of seal, and is not meant to imply that the seal must include glass.

[0379] The housing **7** for the ultracapacitor **10** may be made from, for example, types 304, 304L, 316, and 316L stainless steels. They may also be constructed from, but not limited to, some of the aluminum alloys, such as 1100, 3003, 5052, 4043 and 6061. Various multi-layer materials may be used, and may include, for example, aluminum clad to stainless steel. Other non-limiting compatible metals that may be used include platinum, gold, rhodium, ruthenium and silver.

[0380] Specific examples of glass-to-metal seals that have been used in the ultracapacitor **10** include two different types of glass-to-metal seals. A first one is from SCHOTT with a US location in Elmsford, N.Y. This embodiment uses a stainless steel pin, glass insulator, and a stainless steel body. A second glass-to-metal seal is from HERMETIC SEAL TECHNOLOGY of Cincinnati, Ohio. This second embodiment uses a tantalum pin, glass insulator and a stainless steel body. Varying sizes of the various embodiments may be provided.

[0381] An additional embodiment of the glass-to-metal seal includes an embodiment that uses an aluminum seal and an aluminum body. Yet another embodiment of the glass-to-metal seal includes an aluminum seal using epoxy or other insulating materials (such as ceramics or silicon).

[0382] A number of aspects of the glass-to-metal seal may be configured as desired. For example, dimensions of housing and pin, and the material of the pin and housing may be modified as appropriate. The pin can also be a tube or solid pin, as well as have multiple pins in one cover. While the most common types of material used for the pin are stainless steel alloys, copper cored stainless steel, molybdenum, platinum-iridium, various nickel-iron alloys, tantalum and other metals, some non-traditional materials may be used (such as aluminum). The housing is usually formed of stainless steel, titanium and/or various other materials.

[0383] A variety of fastening techniques may be used in assembly of the ultracapacitor **10**. For example, and with regards to welding, a variety of welding techniques may be used. The following is an illustrative listing of types of welding and various purposes for which each type of welding may be used.

[0384] Ultrasonic welding may be used for, among other things: welding aluminum tabs to the current collector;

welding tabs to the bottom clad cover; welding a jumper tab to the clad bridge connected to the glass-to-metal seal pin; and welding jelly roll tabs together. Pulse or resistance welding may be used for, among other things: welding leads onto the bottom of the can or to the pin; welding leads to the current collector; welding a jumper to a clad bridge; welding a clad bridge to the terminal **8**; welding leads to a bottom cover. Laser welding may be used for, among other things: welding a stainless steel cover to a stainless steel can; welding a stainless steel bridge to a stainless steel glass-to-metal seal pin; and welding a plug into the fill port. TIG welding may be used for, among other things: sealing aluminum covers to an aluminum can; and welding aluminum seal into place. Cold welding (compressing metals together with high force) may be used for, among other things: sealing the fillport by force fitting an aluminum ball/tack into the fill port.

[0385] ii. Certain Advantageous Embodiments of the Fabrication

[0386] Certain advantageous embodiments, which are not intended to be limiting are provided herein below.

[0387] In one particular embodiment, and referring to FIG. **29**, components of an exemplary electrode **3** are shown. In this example, the electrode **3** will be used as the negative electrode **3** (however, this designation is arbitrary and merely for referencing).

[0388] As may be noted from the illustration, at least in this embodiment, the separator **5** is generally of a longer length and wider width than the energy storage media **1** (and the current collector **2**). By using a larger separator **5**, protection is provided against short circuiting of the negative electrode **3** with the positive electrode **3**. Use of additional material in the separator **5** also provides for better electrical protection of the leads and the terminal **8**.

[0389] Refer now to FIG. **30** which provides a side view of an embodiment of the storage cell **12**. In this example, a layered stack of energy storage media **1** includes a first separator **5** and a second separator **5**, such that the electrodes **3** are electrically separated when the storage cell **12** is assembled into a rolled storage cell **23**. Note that the term “positive” and “negative” with regard to the electrode **3** and assembly of the ultracapacitor **10** is merely arbitrary, and makes reference to functionality when configured in the ultracapacitor **10** and charge is stored therein. This convention, which has been commonly adopted in the art, is not meant to apply that charge is stored prior to assembly, or connote any other aspect other than to provide for physical identification of different electrodes.

[0390] Prior to winding the storage cell **12**, the negative electrode **3** and the positive electrode **3** are aligned with respect to each other. Alignment of the electrodes **3** gives better performance of the ultracapacitor **10** as a path length for ionic transport is generally minimized when there is a highest degree of alignment. Further, by providing a high degree of alignment, excess separator **5** is not included and efficiency of the ultracapacitor **10** does not suffer as a result.

[0391] Referring now also to FIG. **31**, there is shown an embodiment of the storage cell **12** wherein the electrodes **3** have been rolled into the rolled storage cell **23**. One of the separators **5** is present as an outermost layer of the storage cell **12** and separates energy storage media **1** from an interior of the housing **7**.

[0392] “Polarity matching” may be employed to match a polarity of the outermost electrode in the rolled storage cell

23 with a polarity of the body **20**. For example, in some embodiments, the negative electrode **3** is on the outermost side of the tightly packed package that provides the rolled storage cell **23**. In these embodiments, another degree of assurance against short circuiting is provided. That is, where the negative electrode **3** is coupled to the body **20**, the negative electrode **3** is placed as the outermost electrode in the rolled storage cell **23**. Accordingly, should the separator **5** fail, such as by mechanical wear induced by vibration of the ultracapacitor **10** during usage, the ultracapacitor **10** will not fail as a result of a short circuit between the outermost electrode in the rolled storage cell **23** and the body **20**.

[0393] For each embodiment of the rolled storage cell **23**, a reference mark **72** may be in at least the separator **5**. The reference mark **72** will be used to provide for locating the leads on each of the electrodes **3**. In some embodiments, locating of the leads is provided for by calculation. For example, by taking into account an inner diameter of the jelly roll and an overall thickness for the combined separators **5** and electrodes **3**, a location for placement of each of the leads may be estimated. However, practice has shown that it is more efficient and effective to use a reference mark **72**. The reference mark **72** may include, for example, a slit in an edge of the separator(s) **5**.

[0394] Generally, the reference mark **72** is employed for each new specification of the storage cell **12**. That is, as a new specification of the storage cell **12** may call for differing thickness of at least one layer therein (over a prior embodiment), use of prior reference marks may be at least somewhat inaccurate.

[0395] In general, the reference mark **72** is manifested as a single radial line that traverses the roll from a center thereof to a periphery thereof. Accordingly, when the leads are installed along the reference mark **72**, each lead will align with the remaining leads (as shown in FIG. 10). However, when the storage cell **12** is unrolled (for embodiments where the storage cell **12** is or will become a roll), the reference mark **72** may be considered to be a plurality of markings (as shown in FIG. 32). As a matter of convention, regardless of the embodiment or appearance of marking of the storage cell **12**, identification of a location for incorporation of the lead is considered to involve determination of a “reference mark **72**” or a “set of reference marks **72**.”

[0396] Referring now to FIG. 32, once the reference mark **72** has been established (such as by marking a rolled up storage cell **12**), an installation site for installation each of the leads is provided (i.e., described by the reference mark **72**). Once each installation site has been identified, for any given build specification of the storage cell **12**, the relative location of each installation site may be repeated for additional instances of the particular build of storage cell **12**.

[0397] Generally, each lead is coupled to a respective current collector **2** in the storage cell **12**. In some embodiments, both the current collector **2** and the lead are fabricated from aluminum. Generally, the lead is coupled to the current collector **2** across the width, *W*, however, the lead may be coupled for only a portion of the width, *W*. The coupling may be accomplished by, for example, ultrasonic welding of the lead to the current collector **2**. In order to accomplish the coupling, at least some of the energy storage media **1** may be removed (as appropriate) such that each lead may be appropriately joined with the current collector **2**.

Other preparations and accommodations may be made, as deemed appropriate, to provide for the coupling.

[0398] In certain embodiments, opposing reference marks **73** may be included. That is, in the same manner as the reference marks **72** are provided, a set of opposing reference marks **73** may be made to account for installation of leads for the opposing polarity. That is, the reference marks **72** may be used for installing leads to a first electrode **3**, such as the negative electrode **3**, while the opposing reference marks **73** may be used for installing leads to the positive electrode **3**. In the embodiment where the rolled storage cell **23** is cylindrical, the opposing reference marks **73** are disposed on an opposite side of the energy storage media **1**, and offset lengthwise from the reference marks **72** (as depicted).

[0399] Note that in FIG. 32, the reference marks **72** and the opposing reference marks **73** are both shown as being disposed on a single electrode **3**. That is, FIG. 29 depicts an embodiment that is merely for illustration of spatial (i.e., linear) relation of the reference marks **72** and the opposing reference marks **73**. This is not meant to imply that the positive electrode **3** and the negative electrode **3** share energy storage media **1**. However, it should be noted that in instances where the reference marks **72** and the opposing reference marks **73** are placed by rolling up the storage cell **12** and then marking the separator **5**, that the reference marks **72** and the opposing reference marks **73** may indeed be provided on a single separator **5**. However, in practice, only one set of the reference marks **72** and the opposing reference marks **73** would be used to install the leads for any given electrode **3**. That is, it should be recognized that the embodiment depicted in FIG. 32 is to be complimented with another layer of energy storage media **1** for another electrode **3** which will be of an opposing polarity.

[0400] As shown in FIG. 33, the foregoing assembly technique results in a storage cell **12** that includes at least one set of aligned leads. A first set of aligned leads **91** are particularly useful when coupling the rolled storage cell **23** to one of the negative contact **55** and the positive contact **56**, while a set of opposing aligned leads **92** provide for coupling the energy storage media **1** to an opposite contact (**55**, **56**).

[0401] The rolled storage cell **23** may be surrounded by a wrapper **93**. The wrapper **93** may be realized in a variety of embodiments. For example, the wrapper **93** may be provided as KAPTON™ tape (which is a polyimide film developed by DuPont of Wilmington Del.), or PTFE tape. In this example, the KAPTON™ tape surrounds and is adhered to the rolled storage cell **23**. The wrapper **93** may be provided without adhesive, such as a tightly fitting wrapper **93** that is slid onto the rolled storage cell **23**. The wrapper **93** may be manifested more as a bag, such as one that generally engulfs the rolled storage cell **23** (e.g., such as the envelope **73** discussed above). In some of these embodiments, the wrapper **93** may include a material that functions as a shrink-wrap would, and thereby provides an efficient physical (and in some embodiments, chemical) enclosure of the rolled storage cell **23**. Generally, the wrapper **93** is formed of a material that does not interfere with electrochemical functions of the ultracapacitor **10**. The wrapper **93** may also provide partial coverage as needed, for example, to aid insertion of the rolled storage cell **23**.

[0402] In some embodiments, the negative leads and the positive leads are located on opposite sides of the rolled storage cell **23** (in the case of a jelly-roll type rolled storage

cell **23**, the leads for the negative polarity and the leads for the positive polarity may be diametrically opposed). Generally, placing the leads for the negative polarity and the leads for the positive polarity on opposite sides of the rolled storage cell **23** is performed to facilitate construction of the rolled storage cell **23** as well as to provide improved electrical separation.

[0403] In some embodiments, once the aligned leads **91**, **92** are assembled, each of the plurality of aligned leads **91**, **92** are bundled together (in place) such that a shrink-wrap (not shown) may be disposed around the plurality of aligned leads **91**, **92**. Generally, the shrink-wrap is formed of PTFE, however, any compatible material may be used.

[0404] In some embodiments, once shrink-wrap material has been placed about the aligned leads **91**, the aligned leads **91** are folded into a shape to be assumed when the ultracapacitor **10** has been assembled. That is, with reference to FIG. **34**, it may be seen that the aligned leads assume a “Z” shape. After imparting a “Z-fold” into the aligned leads **91**, **92** and applying the shrink-wrap, the shrink-wrap may be heated or otherwise activated such that the shrink-wrap shrinks into place about the aligned leads **91**, **92**. Accordingly, in some embodiments, the aligned leads **91**, **92** may be strengthened and protected by a wrapper. Use of the Z-fold is particularly useful when coupling the energy storage media **1** to the feed-through **19** disposed within the cap **24**.

[0405] Additionally, other embodiments for coupling each set of aligned leads **91**, **92** (i.e., each terminal **8**) to a respective contact **55**, **56** may be practiced. For example, in one embodiment, an intermediate lead is coupled to the one of the feed-through **19** and the housing **7**, such that coupling with a respective set of aligned leads **91**, **92** is facilitated.

[0406] Furthermore, materials used may be selected according to properties such as reactivity, dielectric value, melting point, adhesion to other materials, weldability, coefficient of friction, cost, and other such factors. Combinations of materials (such as layered, mixed, or otherwise combined) may be used to provide for desired properties.

[0407] iii. Particular Ultracapacitor Embodiments

[0408] Physical aspects of an exemplary ultracapacitor **10** of the present invention are shown below. Note that in the following tables, the terminology “tab” generally refers to the “lead” as discussed above; the terms “bridge” and “jumper” also making reference to aspects of the lead (for example, the bridge may be coupled to the feed-through, or “pin,” while the jumper is useful for connecting the bridge to the tabs, or leads). Use of various connections may facilitate the assembly process, and take advantage of certain assembly techniques. For example, the bridge may be laser welded or resistance welded to the pin, and coupled with an ultrasonic weld to the jumper.

TABLE 5

Weights of Complete Cell With Electrolyte		
Component	Weight (grams)	Percent of total
SS Can (body of the housing)	14.451	20.87%
SS Top cover (cap)	5.085	7.34%
Tantalum glass-metal Seal	12.523	18.09%
SS/Al Clad Bottom	10.150	14.66%
Tack (seal for fill hole)	0.200	0.29%
Inner Electrode (cleared, no tabs)	3.727	5.38%
Inner Electrode Aluminum	1.713	2.47%
Inner Electrode Carbon	2.014	2.91%
Outer Electrode (cleared, no tabs)	4.034	5.83%

TABLE 5-continued

Weights of Complete Cell With Electrolyte		
Component	Weight (grams)	Percent of total
Outer Electrode Aluminum	1.810	2.61%
Outer Electrode Carbon	2.224	3.21%
Separator	1.487	2.15%
Alum. Jelly roll Tabs (all 8)	0.407	0.59%
Ta/Al clad bridge	0.216	0.31%
Alum. Jumper (bridge-JR tabs)	0.055	0.08%
Teflon heat shrink	0.201	0.29%
AES	16.700	24.12%
Total Weight	69.236	100.00%

TABLE 6

Weights of Complete Cell Without Electrolyte		
Component	Weight (grams)	Percent of total
SS Can	14.451	27.51%
SS Top cover	5.085	9.68%
Tantalum glass-metal Seal	12.523	23.84%
SS/Al Clad Bottom	10.150	19.32%
Tack	0.200	0.38%
Inner Electrode (cleared, no tabs)	3.727	7.09%
Outer Electrode (cleared, no tabs)	4.034	7.68%
Separator	1.487	2.83%
Alum. Jelly roll Tabs (all 8)	0.407	0.77%
Ta/Al clad bridge	0.216	0.41%
Alum. Jumper (bridge-JR tabs)	0.055	0.10%
Teflon heat shrink	0.201	0.38%
Total Weight	52.536	100.00%

TABLE 7

Weights of Cell Components in Full Cell with Electrolyte		
Component	Weight (grams)	Percent of total
Can, covers, seal, bridge, jumper, heat shrink, tack	42.881	61.93%
Jelly Roll with Electrodes, tabs, separator	9.655	13.95%
Electrolyte	16.700	24.12%
Total Weight	69.236	100.00%

TABLE 8

Weights of Electrode		
Component	Weight (grams)	Percent of total
Inner electrode carbon	2.014	25.95%
Inner electrode aluminum	1.713	22.07%
Outer electrode carbon	2.224	28.66%
Outer electrode aluminum	1.810	23.32%
Total Weight	7.761	100.00%

[0409] FIGS. 35-38 are graphs depicting performance of these exemplary ultracapacitors 10. FIGS. 35 and 36 depict performance of the ultracapacitor 10 at 1.75 volts and 125 degrees Celsius. FIGS. 37 and 38 depict performance of the ultracapacitor 10 at 1.5 volts and 150 degrees Celsius.

[0410] Generally, the ultracapacitor 10 may be used under a variety of environmental conditions and demands. For example, terminal voltage may range from about 100 mV to 10 V. Ambient temperatures may range from about minus 40 degrees Celsius to plus 210 degrees Celsius. Typical high temperature ambient temperatures range from plus 60 degrees Celsius to plus 210 degrees Celsius.

[0411] FIGS. 39-43 are additional graphs depicting performance of exemplary ultracapacitors 10. In these examples, the ultracapacitor 10 was a closed cell (i.e., housing). The ultracapacitor was cycled 10 times, with a charge and discharge of 100 mA, charged to 0.5 Volts, resistance measurement, discharged to 10 mV, 10 second rest then cycled again.

[0412] Tables 11 and 12 provide comparative performance data for these embodiments of the ultracapacitor 10. The performance data was collected for a variety of operating conditions as shown.

TABLE 9

Comparative Performance Data									
Cell #	Temperature (° C.)	Voltage (V)	Time (Hrs)	ESR Initial (mOhm)	% ESR Increase	Capacitance Initial (F)	% Capacitance Decrease	Cell Weight (g)	Ending Current (mA)
D2011-09	150	1.25	1500	30	0	93	5	—	0.5
C1041-02	150	1.5	1150	45	60	32	—	28.35	0.5
C2021-01	150	1.5	1465	33	100	32	70	26.61	0.8
D5311-01	150	1.6	150	9	10	87	4	—	5
C6221-05	150	1.75	340	15	50	—	—	38.31	1
C6221-05	150	1.75	500	15	100	—	—	38.31	2
C6221-05	150	1.75	600	15	200	—	—	38.31	2
C6221-05	150	1.75	650	15	300	—	—	38.31	2
D1043-02	150	1.75	615	43	50	100	—	—	3
D1043-02	150	1.75	700	43	100	100	—	—	3
C5071-01	150	1.75	600	26	100	27	32	—	2
C5071-01	150	1.75	690	26	200	27	35	—	2
C5071-01	150	1.75	725	26	300	27	50	—	2
C8091-06	125	1.75	500	38	5	63	11	37.9	0.5
C9021-02	125	1.75	1250	37	10	61	—	39.19	0.3
D5011-02	125	1.9	150	13	0	105	0	—	1.4
C8091-06	125	2	745	41	22	56	—	37.9	1.2
D2011-08	175	1	650	33	12	89	30	—	4
D1043-10	175	1.3	480	30	100	93	50	—	6.5
C2021-04	175	1.4	150	35	100	27	—	27.17	3.5
C4041-04	210	0.5	10	28	0	32	—	28.68	1
C4041-04	210	0.5	20	28	0	32	—	28.68	7
C4041-04	210	0.5	50	28	100	32	—	28.68	18

TABLE 10

Comparative Performance Data												
Cell #	T (° C.)	Voltage (V)	Time (Hrs)	ESR Initial (mOhm)	Initial Capacitance (F)	Leakage Current (mA)	Volumetric ESR (Ohms × cc)	Volumetric Capacitance (F/cc)	Volumetric Leakage Current (mA/cc)	% ESR Increase	% Capacitance Decrease	Volume (cc)
D2011-09	150	1.25	1500	30	93	0.5	0.75	3.72	0.02	0	5	25
C2021-01	150	1.5	1465	33	32	0.75	0.396	2.67	0.06	100	5	12
C5071-01	150	1.75	600	26	27	2	0.338	2.08	0.15	100	32	13
C5071-01	150	1.75	690	26	27	2	0.338	2.08	0.15	200	35	13
C5071-01	150	1.75	725	26	27	2	0.338	2.08	0.15	300	50	13
C8091-06	125	1.75	500	38	63	0.5	0.494	4.85	0.04	5	11	13
C9021-02	125	1.75	1250	37	61	0.25	0.481	4.69	0.02	10	11	13
D2011-08	175	1	650	33	89	4	0.825	3.56	0.16	12	30	25
D1043-10	175	1.3	480	30	93	6.5	0.75	3.72	0.26	100	50	25
C4041-04	210	0.5	50	28	32	18	0.336	2.67	1.50	100	50	12

[0413] Thus, data provided in Tables 9 and 10 demonstrate that the teachings herein enable performance of ultracapacitors in extreme conditions. Ultracapacitors fabricated accordingly may, for example, exhibit leakage currents of less than about 1 mA per milliliter of cell volume, and an ESR increase of less than about 100 percent in 500 hours (while held at voltages of less than about 2 V and temperatures less than about 150 degrees Celsius). As trade-offs may be made among various demands of the ultracapacitor (for example, voltage and temperature) performance ratings for the ultracapacitor may be managed (for example, a rate of increase for ESR, capacitance, etc) may be adjusted to accommodate a particular need. Note that in reference to the foregoing, “performance ratings” is given a generally conventional definition, which is with regard to values for parameters describing conditions of operation.

[0414] FIGS. 35 through 43 depict performance of an exemplary ultracapacitor having AES comprising 1-butyl-1-methylpyrrolidinium and tetracyanoborate for temperatures in the range from 125 degrees Celsius to 210 degrees Celsius.

[0415] FIGS. 44A and 44B depict performance data of an exemplary ultracapacitor having AES comprising 1-butyl-1-methylpiperdinium bis(trifluoromethylsulfonyl)imide.

[0416] FIGS. 45A and 45B depict performance data of an exemplary ultracapacitor having AES comprising trihexyltetradecylphosphonium bis(trifluoromethylsulfonyl)imide.

[0417] FIGS. 46A and 46B depict performance data of an exemplary ultracapacitor having AES comprising butyltrimethylammonium bis(trifluoromethylsulfonyl)imide.

[0418] FIGS. 47A and 47B depict performance data of an exemplary ultracapacitor having AES comprising 1-butyl-1-methylpyrrolidinium and tetracyanoborate at 125 degrees Celsius.

[0419] FIGS. 48A and 48B and 49 depict performance data of an exemplary ultracapacitor having AES comprising a mixture of propylene carbonate and 1-butyl-1-methylpyrrolidinium and tetracyanoborate, the mixture being about 37.5% propylene carbonate by volume; the capacitor operating at 125 degrees Celsius (FIGS. 48A and 48B) and at -40 degrees Celsius (FIG. 49). Another exemplary ultracapacitor tested included an AES comprising 1-butyl-3-methylimidazolium tetrafluoroborate.

[0420] Another exemplary ultracapacitor tested included an AES comprising 1-butyl-3-methylimidazolium bis(trifluoromethylsulfonyl)imide.

[0421] Another exemplary ultracapacitor tested included an AES comprising 1-ethyl-3-methylimidazolium tetrafluoroborate.

[0422] Another exemplary ultracapacitor tested included an AES comprising 1-ethyl-3-methylimidazolium tetracyanoborate.

[0423] Another exemplary ultracapacitor tested included an AES comprising 1-hexyl-3-methylimidazolium tetracyanoborate.

[0424] Another exemplary ultracapacitor tested included an AES comprising 1-butyl-1-methylpyrrolidinium bis(trifluoromethylsulfonyl)imide

[0425] Another exemplary ultracapacitor tested included an AES comprising 1-butyl-1-methylpyrrolidinium tris(pentafluoroethyl)trifluorophosphate.

[0426] Another exemplary ultracapacitor tested included an AES comprising 1-butyl-1-methylpyrrolidinium tetracyanoborate.

[0427] Another exemplary ultracapacitor tested included an AES comprising 1-butyl-3-methylimidazolium trifluoromethanesulfonate.

[0428] Another exemplary ultracapacitor tested included an AES comprising 1-ethyl-3-methylimidazolium tetracyanoborate.

[0429] Another exemplary ultracapacitor tested included an AES comprising 1-ethyl-3-methylimidazolium and 1-butyl-1-methylpyrrolidinium and tetracyanoborate.

[0430] Another exemplary ultracapacitor tested included an AES comprising 1-butyl-1-methylpyrrolidinium and tetracyanoborate and ethyl isopropyl sulfone.

[0431] Note that measures of capacitance as well as ESR, as presented in Table 9 and elsewhere herein, followed generally known methods. Consider first, techniques for measuring capacitance.

[0432] Capacitance may be measured in a number of ways. One method involves monitoring the voltage presented at the capacitor terminals while a known current is drawn from (during a “discharge”) or supplied to (during a “charge”) of the ultracapacitor. More specifically, we may use the fact that an ideal capacitor is governed by the equation:

$$I=C*dV/dt,$$

where I represents charging current, C represents capacitance and dV/dt represents the time-derivative of the ideal capacitor voltage, V. An ideal capacitor is one whose internal resistance is zero and whose capacitance is voltage-independent, among other things. When the charging current, I, is constant, the voltage V is linear with time, so dV/dt may be computed as the slope of that line, or as DeltaV/DeltaT. However, this method is generally an approximation and the voltage difference provided by the effective series resistance (the ESR drop) of the capacitor should be considered in the computation or measurement of a capacitance. The effective series resistance (ESR) may generally be a lumped element approximation of dissipative or other effects within a capacitor. Capacitor behavior is often derived from a circuit model comprising an ideal capacitor in series with a resistor having a resistance value equal to the ESR. Generally, this yields good approximations to actual capacitor behavior.

[0433] In one method of measuring capacitance, one may largely neglect the effect of the ESR drop in the case that the internal resistance is substantially voltage-independent, and the charging or discharging current is substantially fixed. In that case, the ESR drop may be approximated as a constant and is naturally subtracted out of the computation of the change in voltage during said constant-current charge or discharge. Then, the change in voltage is substantially a reflection of the change in stored charge on the capacitor. Thus, that change in voltage may be taken as an indicator, through computation, of the capacitance.

[0434] For example, during a constant-current discharge, the constant current, I, is known. Measuring the voltage change during the discharge, DeltaV, during a measured time interval DeltaT, and dividing the current value I by the ratio DeltaV/DeltaT, yields an approximation of the capacitance. When I is measured in amperes, Delta V in volts, and DeltaT in seconds, the capacitance result will be in units of Farads.

[0435] Turning to estimation of ESR, the effective series resistance (ESR) of the ultracapacitor may also be measured in a number of ways. One method involves monitoring the voltage presented at the capacitor terminals while a known current is drawn from (during a “discharge”) or supplied to (during a “charge”) the ultracapacitor. More specifically, one may use the fact that ESR is governed by the equation:

$$V=I*R,$$

where I represents the current effectively passing through the ESR, R represents the resistance value of the ESR, and V represents the voltage difference provided by the ESR (the ESR drop). ESR may generally be a lumped element approximation of dissipative or other effects within the ultracapacitor. Behavior of the ultracapacitor is often derived from a circuit model comprising an ideal capacitor in series with a resistor having a resistance value equal to the ESR. Generally, this yields good approximations of actual capacitor behavior.

[0436] In one method of measuring ESR, one may begin drawing a discharge current from a capacitor that had been at rest (one that had not been charging or discharging with a substantial current). During a time interval in which the change in voltage presented by the capacitor due to the change in stored charge on the capacitor is small compared to the measured change in voltage, that measured change in voltage is substantially a reflection of the ESR of the capacitor. Under these conditions, the immediate voltage change presented by the capacitor may be taken as an indicator, through computation, of the ESR.

[0437] For example, upon initiating a discharge current draw from a capacitor, one may be presented with an immediate voltage change ΔV over a measurement interval ΔT . So long as the capacitance of the capacitor, C, discharged by the known current, I, during the measurement interval, ΔT , would yield a voltage change that is small compared to the measured voltage change, ΔV , one may divide ΔV during the time interval ΔT by the discharge current, I, to yield an approximation to the ESR. When I is measured in amperes and ΔV in volts, the ESR result will have units of Ohms.

[0438] Both ESR and capacitance may depend on ambient temperature. Therefore, a relevant measurement may require the user to subject the ultracapacitor **10** to a specific ambient temperature of interest during the measurement.

[0439] Performance requirements for leakage current are generally defined by the environmental conditions prevalent in a particular application. For example, with regard to a capacitor having a volume of 20 mL, a practical limit on leakage current may fall below 100 mA.

[0440] Nominal values of normalized parameters may be obtained by multiplying or dividing the normalized parameters (e.g. volumetric leakage current) by a normalizing characteristic (e.g. volume). For instance, the nominal leakage current of an ultracapacitor having a volumetric leakage current of 10 mA/cc and a volume of 50 cc is the product of the volumetric leakage current and the volume, 500 mA. Meanwhile the nominal ESR of an ultracapacitor having a volumetric ESR of 20 mOhm·cc and a volume of 50 cc is the quotient of the volumetric ESR and the volume, 0.4 mOhm.

[0441] iv. Examination of Fill Effects on Ultracapacitors Comprising an AES

[0442] Moreover, in order to show how the fill process effects the ultracapacitor **10**, two similar embodiments of the

ultracapacitor **10** were built. One was filled without a vacuum, the other was filled under vacuum. Electrical performance of the two embodiments is provided in Table 11. By repeated performance of such measurements, it has been noted that increased performance is realized with by filling the ultracapacitor **10** through applying a vacuum. It has been determined that, in general, is desired that pressure within the housing **7** is reduced to below about 150 mTorr, and more particularly to below about 40 mTorr.

TABLE 11

Comparative Performance for Fill Methods			
Parameter (at 0.1 V)	Without vacuum	With vacuum	Deviation
ESR @ 45° Φ	3.569 Ohms	2.568 Ohms	(-28%)
Capacitance @ 12 mHz	155.87 mF	182.3 mF	(+14.49%)
Phase @ 12 mHz	79.19 degrees	83 degrees	(+4.59%)

[0443] In order to evaluate efficacy of vacuum filling techniques, two different pouch cells were tested. The pouch cells included two electrodes **3**, each electrode **3** being based on carbonaceous material. Each of the electrodes **3** were placed opposite and facing each other. The separator **5** was disposed between them to prevent short circuit and everything was soaked in electrolyte **6**. Two external tabs were used to provide for four measurement points. The separator **5** used was a polyethylene separator **5**, and the cell had a total volume of about 0.468 ml.

[0444] C. Methods of Use of the Ultracapacitors

[0445] The present invention is also intended to include any and all uses of the energy storage devices, e.g., ultracapacitors, described herein. This would include the direct use of the ultracapacitor, or the use of the ultracapacitor in another other device for any application. Such use is intended to include the manufacture, the offering for sale, or providing of said ultracapacitors to a user.

[0446] For example, in one embodiment, the invention provides a method of using a high temperature rechargeable energy storage device (HTRES) e.g., an ultracapacitor, comprising the steps of obtaining an HTRES comprising an advanced electrolyte system (AES); and cycling the HTRES by alternatively charging and discharging the HTRES at least twice, while maintaining a voltage across the HTRES, such that the HTRES exhibits an initial peak power density between 0.01 W/liter and 150 kW/liter, such that the HTRES is operated at an ambient temperature that is in a temperature range of between about -40 degrees Celsius to about 210 degrees Celsius. In certain embodiments the temperature range is between about -40 degrees Celsius and about 150 degrees Celsius; between about -40 degrees Celsius and about 125 degrees Celsius; between about 80 degrees Celsius and about 210 degrees Celsius; between about 80 degrees Celsius and about 175 degrees Celsius; between about 80 degrees Celsius and about 150 degrees Celsius; or between about -40 degrees Celsius to about 80 degrees Celsius. In certain embodiments, the HTRES exhibits an initial peak power density that is between about 0.01 W/liter and about 10 kW/liter, e.g., between about 0.01 W/liter and about 5 kW/liter, e.g., between about 0.01 W/liter and about 2 kW/liter.

[0447] In another embodiment, the invention provides a method of using an ultracapacitor, the method comprising: obtaining an ultracapacitor of any one of claims **1** to **85**,

wherein the ultracapacitor exhibits a volumetric leakage current (mA/cc) that is less than about 10 mA/cc while held at a substantially constant temperature within a range of between about 100 degrees Celsius and about 150 degrees Celsius; and cycling the ultracapacitor by alternatively charging and discharging the ultracapacitor at least twice, while maintaining a voltage across the ultracapacitor, such that the ultracapacitor exhibits an ESR increase less than about 300 percent after 20 hours of use while held at a substantially constant temperature within a range of between about -40 degrees Celsius to about 210 degrees Celsius. In certain embodiments the temperature range is between about -40 degrees Celsius and about 150 degrees Celsius; between about -40 degrees Celsius and about 125 degrees Celsius; between about 80 degrees Celsius and about 210 degrees Celsius; between about 80 degrees Celsius and about 175 degrees Celsius; between about 80 degrees Celsius and about 150 degrees Celsius; or between about -40 degrees Celsius to about 80 degrees Celsius.

[0448] In another embodiment, the invention provides a method of providing a high temperature rechargeable energy storage device to a user, the method comprising: selecting a high temperature rechargeable energy storage device (HTRES D) comprising an advanced electrolyte system (AES) that exhibits an initial peak power density between 0.01 W/liter and 100 kW/liter and a durability period of at least 1 hour, e.g. for at least 10 hours, e.g. for at least 50 hours, e.g. for at least 100 hours, e.g. for at least 200 hours, e.g. for at least 300 hours, e.g. for at least 400 hours, e.g. for at least 500 hours, e.g. for at least 1,000 hours when exposed to an ambient temperature in a temperature range from about -40 degrees Celsius to about 210 degrees Celsius; and delivering the storage device, such that the HTRES D is provided to the user.

[0449] In another embodiment, the invention provides a method of providing a high temperature rechargeable energy storage device to a user, the method comprising: obtaining an ultracapacitor of any one of claims 1 to 85 that exhibits a volumetric leakage current (mA/cc) that is less than about 10 mA/cc while held at a substantially constant temperature within a range of between about -40 degrees Celsius and about 210 degrees Celsius; and delivering the storage device, such that the HTRES D is provided to the user.

INCORPORATION BY REFERENCE

[0450] The entire contents of all patents, published patent applications and other references cited herein are hereby expressly incorporated herein in their entireties by reference.

EQUIVALENTS

[0451] Those skilled in the art will recognize, or be able to ascertain using no more than routine experimentation,

numerous equivalents to the specific procedures described herein. Such equivalents were considered to be within the scope of this invention and are covered by the following claims. Moreover, any numerical or alphabetical ranges provided herein are intended to include both the upper and lower value of those ranges. In addition, any listing or grouping is intended, at least in one embodiment, to represent a shorthand or convenient manner of listing independent embodiments; as such, each member of the list should be considered a separate embodiment.

[0452] It should be recognized that the teachings herein are merely illustrative and are not limiting of the invention. Further, one skilled in the art will recognize that additional components, configurations, arrangements and the like may be realized while remaining within the scope of this invention. For example, configurations of layers, electrodes, leads, terminals, contacts, feed-throughs, caps and the like may be varied from embodiments disclosed herein. Generally, design and/or application of components of the ultracapacitor and ultracapacitors making use of the electrodes are limited only by the needs of a system designer, manufacturer, operator and/or user and demands presented in any particular situation.

[0453] Further, various other components may be included and called upon for providing for aspects of the teachings herein. For example, additional materials, combinations of materials and/or omission of materials may be used to provide for added embodiments that are within the scope of the teachings herein.

[0454] While the invention has been described with reference to exemplary embodiments, it will be understood that various changes may be made and equivalents may be substituted for elements thereof without departing from the scope of the invention. In addition, many modifications will be appreciated to adapt a particular instrument, situation or material to the teachings of the invention without departing from the essential scope thereof. Therefore, it is intended that the invention not be limited to the particular embodiment disclosed as the best mode contemplated for carrying out this invention but to be construed by the claims appended herein.

1. An ultracapacitor comprising:

an energy storage cell and an advanced electrolyte system (AES) within an hermetically sealed housing, the cell electrically coupled to a positive contact and a negative contact, wherein the ultracapacitor is configured to operate at a temperature within a temperature range between about -40 degrees Celsius to about 210 degrees Celsius.

2-186. (canceled)

* * * * *