



(19) **United States**

(12) **Patent Application Publication**
Briman et al.

(10) **Pub. No.: US 2016/0123947 A1**

(43) **Pub. Date: May 5, 2016**

(54) **AMMONIA NANOSENSORS, AND ENVIRONMENTAL CONTROL SYSTEM**

(71) Applicant: **Nanomix, Inc.**, Emeryville, CA (US)

(72) Inventors: **Mikhail Briman**, Emeryville, CA (US); **Craig Bryant**, Alameda, CA (US); **Ying-Lan Chang**, Cupertino, CA (US); **Jean-Christophe P. Gabriel**, Quaix en Chartreuse (FR); **Shripal C. Ghandi**, Los Angeles, CA (US); **Bradley N. Johnson**, Berkeley, CA (US); **Willem-Jan Ouborg**, Moraga, CA (US); **John Loren Passmore**, Berkeley, CA (US); **Kastooriranganathan Ramakrishnan**, San Rafael, CA (US); **Sergei Skarupo**, Berkeley, CA (US); **Alexander Star**, Pittsburgh, CA (US); **Christian Valcke**, Orinda, CA (US)

now Pat. No. 8,152,991, which is a continuation-in-part of application No. 11/588,845, filed on Oct. 26, 2006, now abandoned.

(60) Provisional application No. 60/748,834, filed on Dec. 9, 2005, provisional application No. 60/730,905, filed on Oct. 27, 2005, provisional application No. 60/773,138, filed on Feb. 13, 2006, provisional application No. 60/850,217, filed on Oct. 6, 2006.

Publication Classification

(51) **Int. Cl.**
G01N 33/00 (2006.01)
G01N 27/12 (2006.01)
(52) **U.S. Cl.**
CPC **G01N 33/0054** (2013.01); **G01N 27/129** (2013.01); **G01N 33/0062** (2013.01); **G01N 2033/0068** (2013.01)

(21) Appl. No.: **14/724,675**

(22) Filed: **May 28, 2015**

Related U.S. Application Data

(63) Continuation of application No. 13/442,720, filed on Apr. 9, 2012, now abandoned, which is a continuation of application No. 11/636,360, filed on Dec. 8, 2006,

(57) **ABSTRACT**

Embodiments of nanoelectronic sensors are described, including sensors for detecting analytes such ammonia. An environmental control system employing nanoelectronic sensors is described. A personnel safety system configured as a disposable badge employing nanoelectronic sensors is described. A method of dynamic sampling and exposure of a sensor providing a number of operational advantages is described.

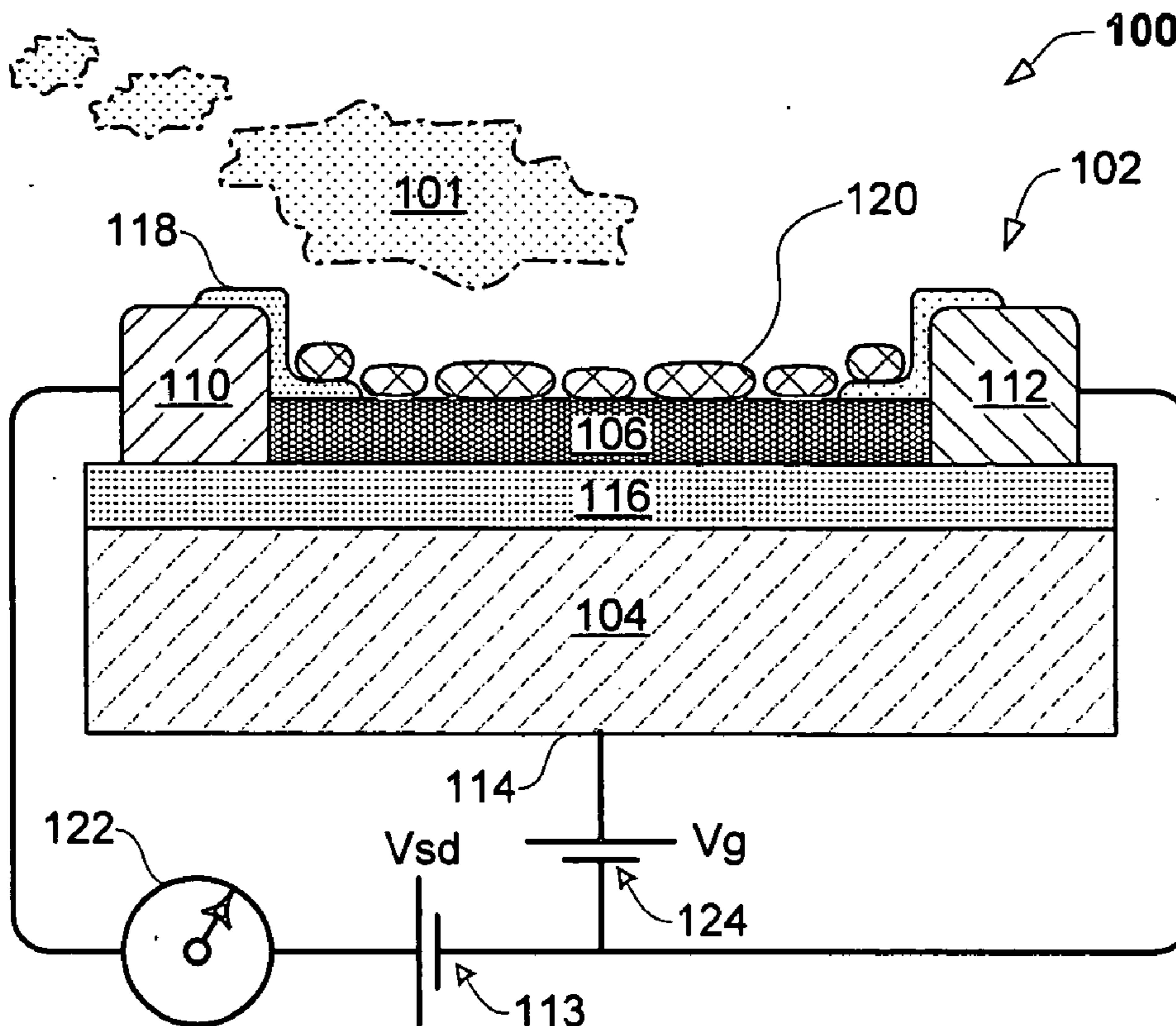

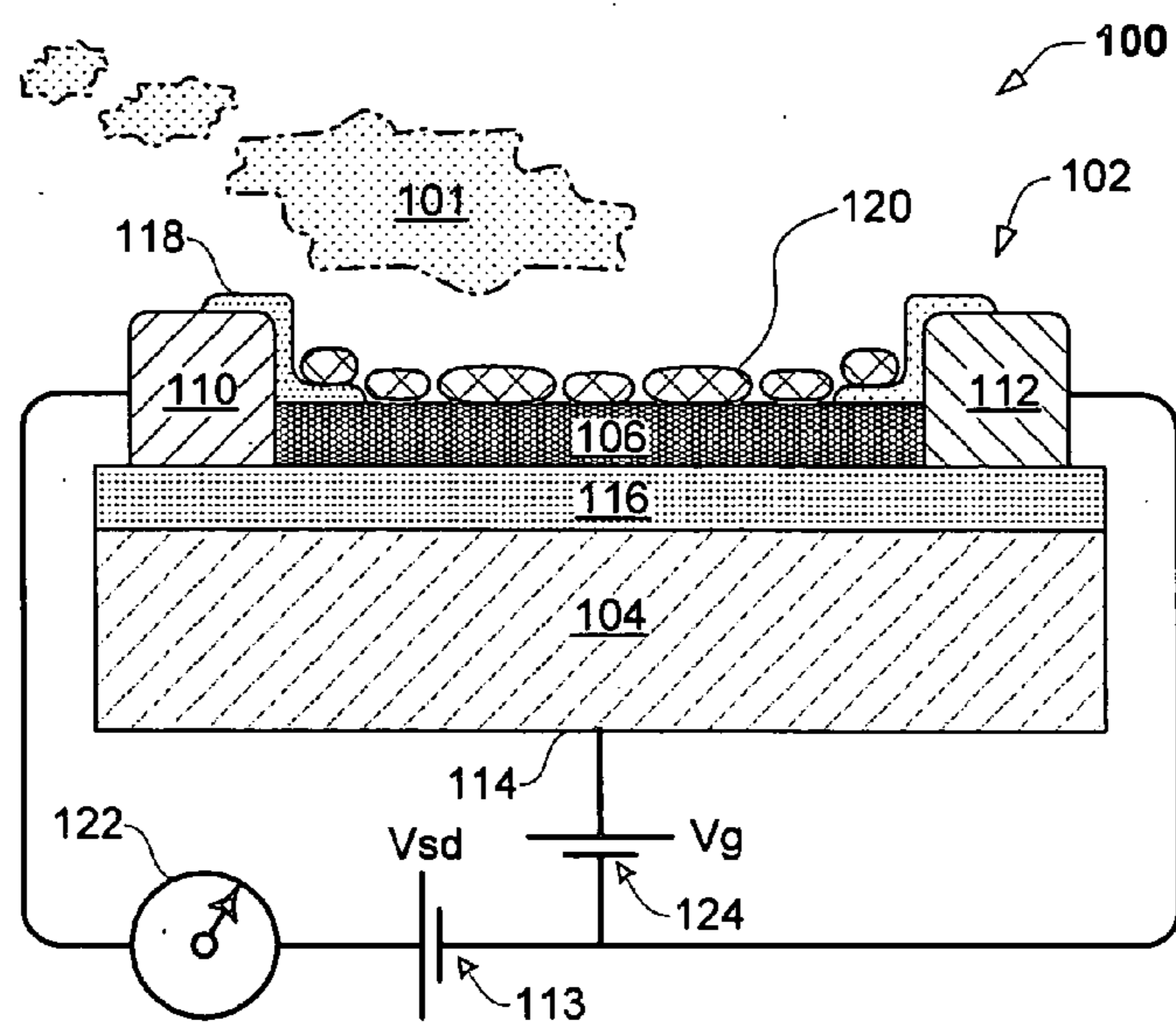

FIG. 1

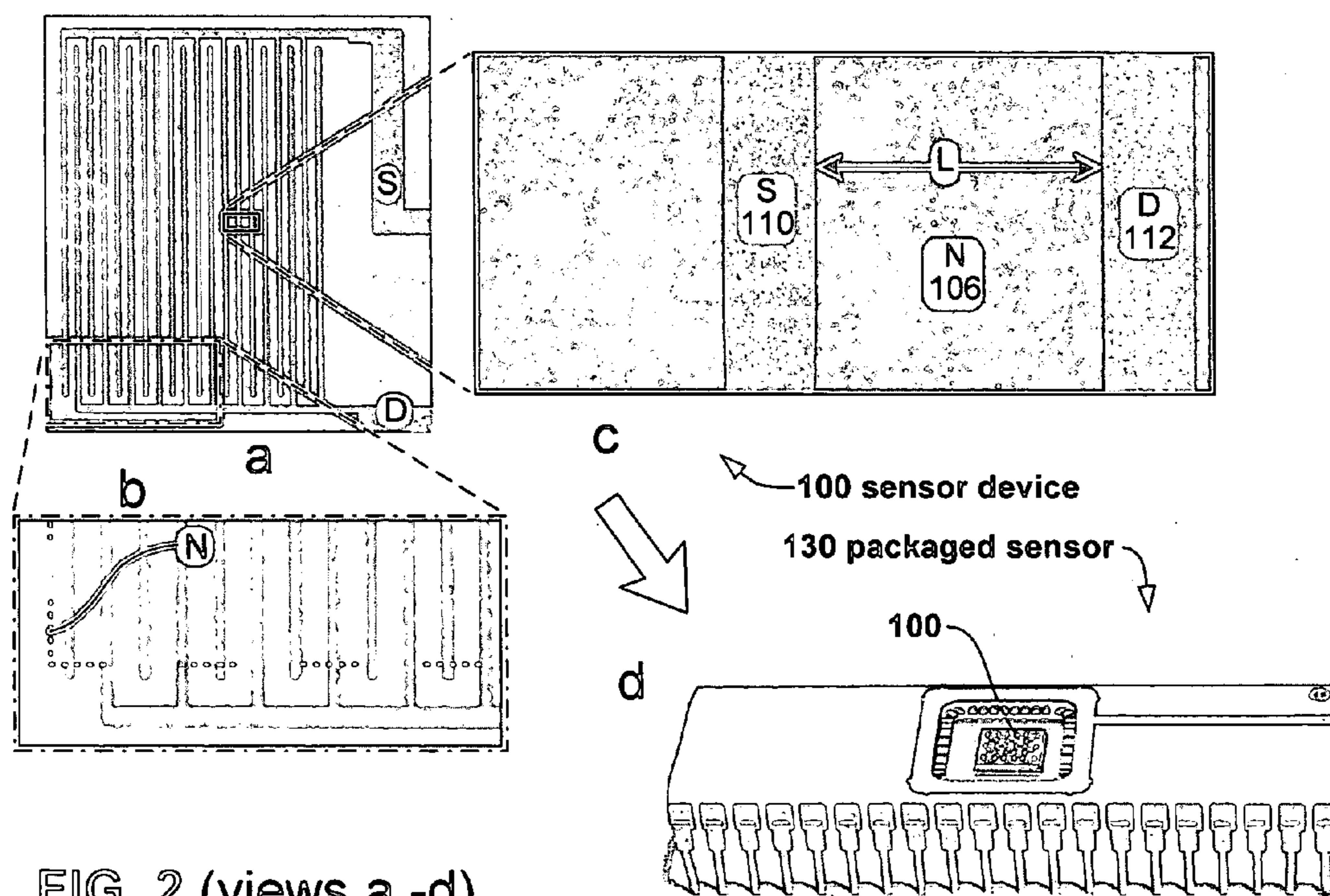

FIG. 2 (views a -d)

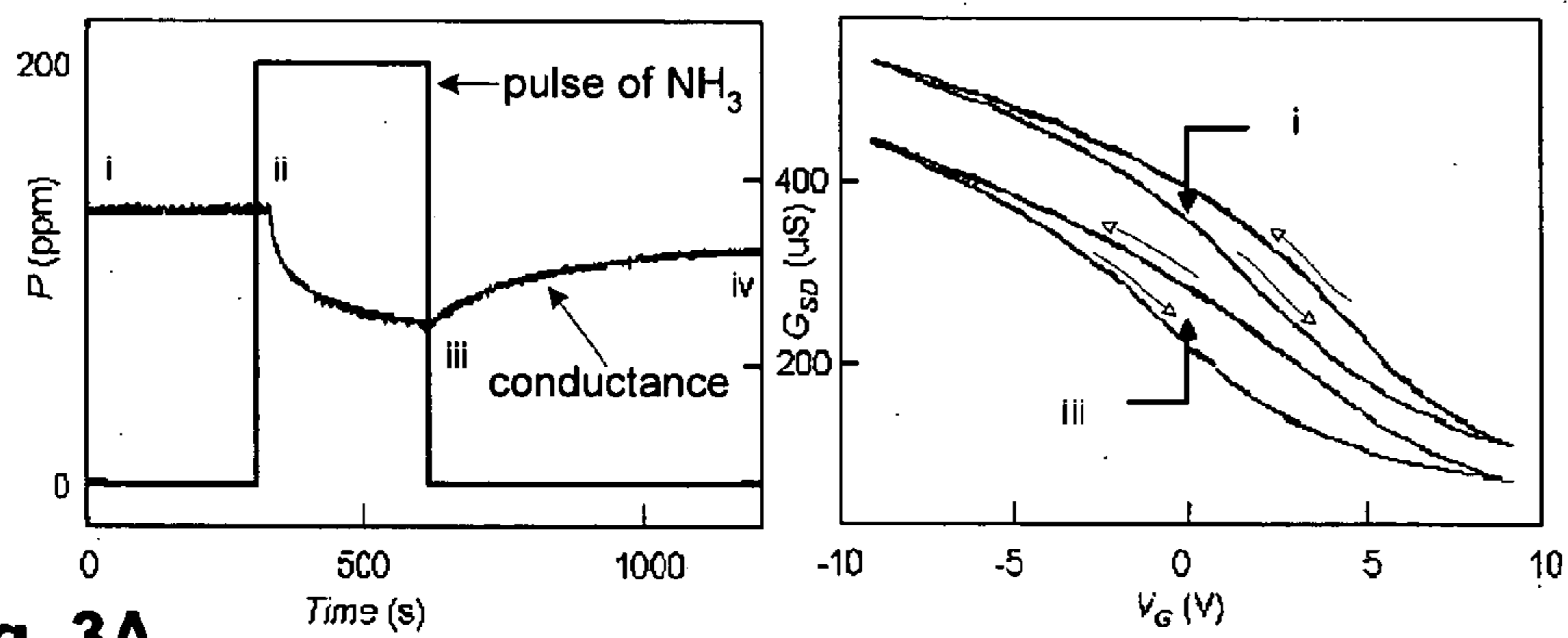

Fig. 3A

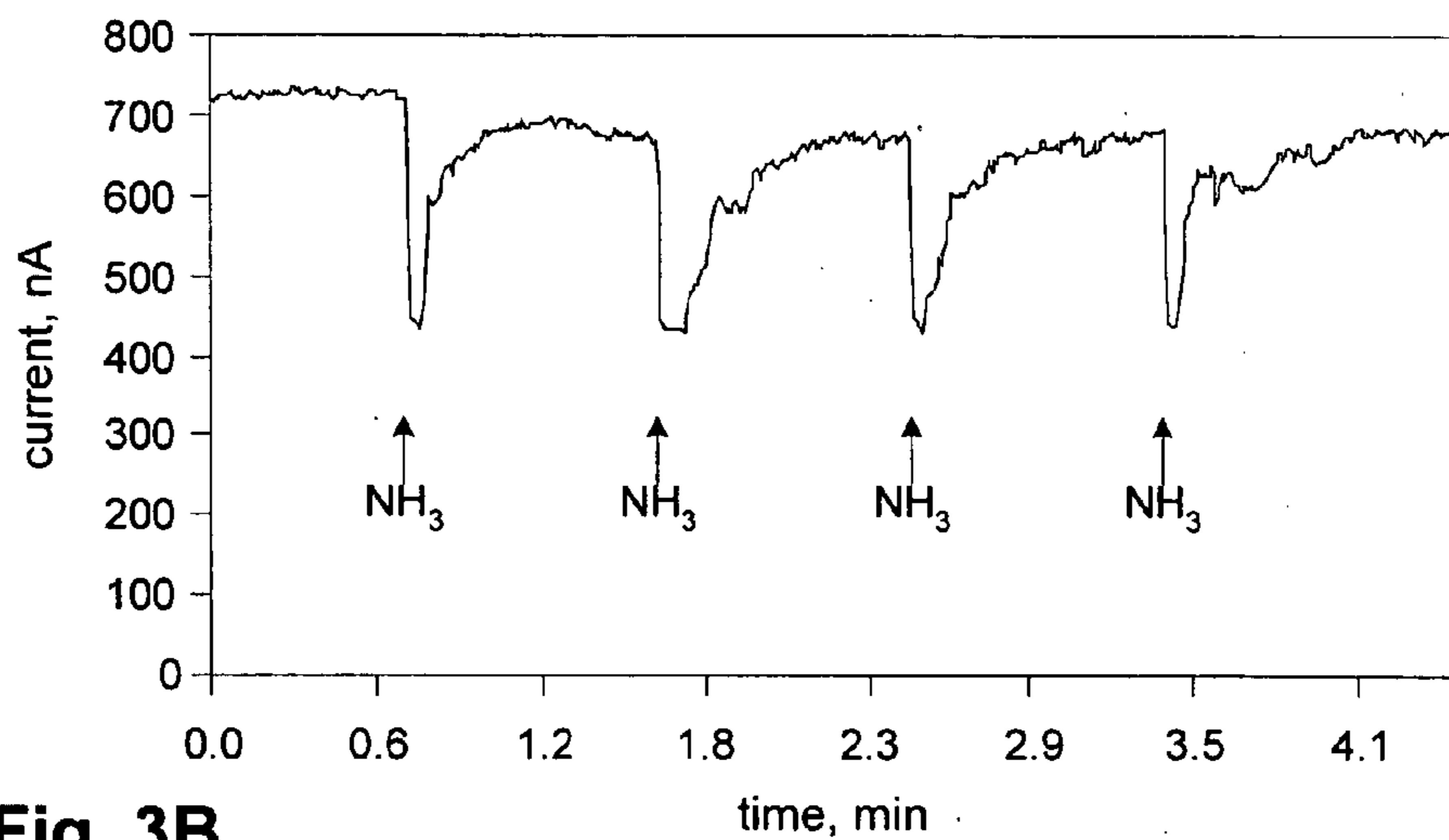

Fig. 3B

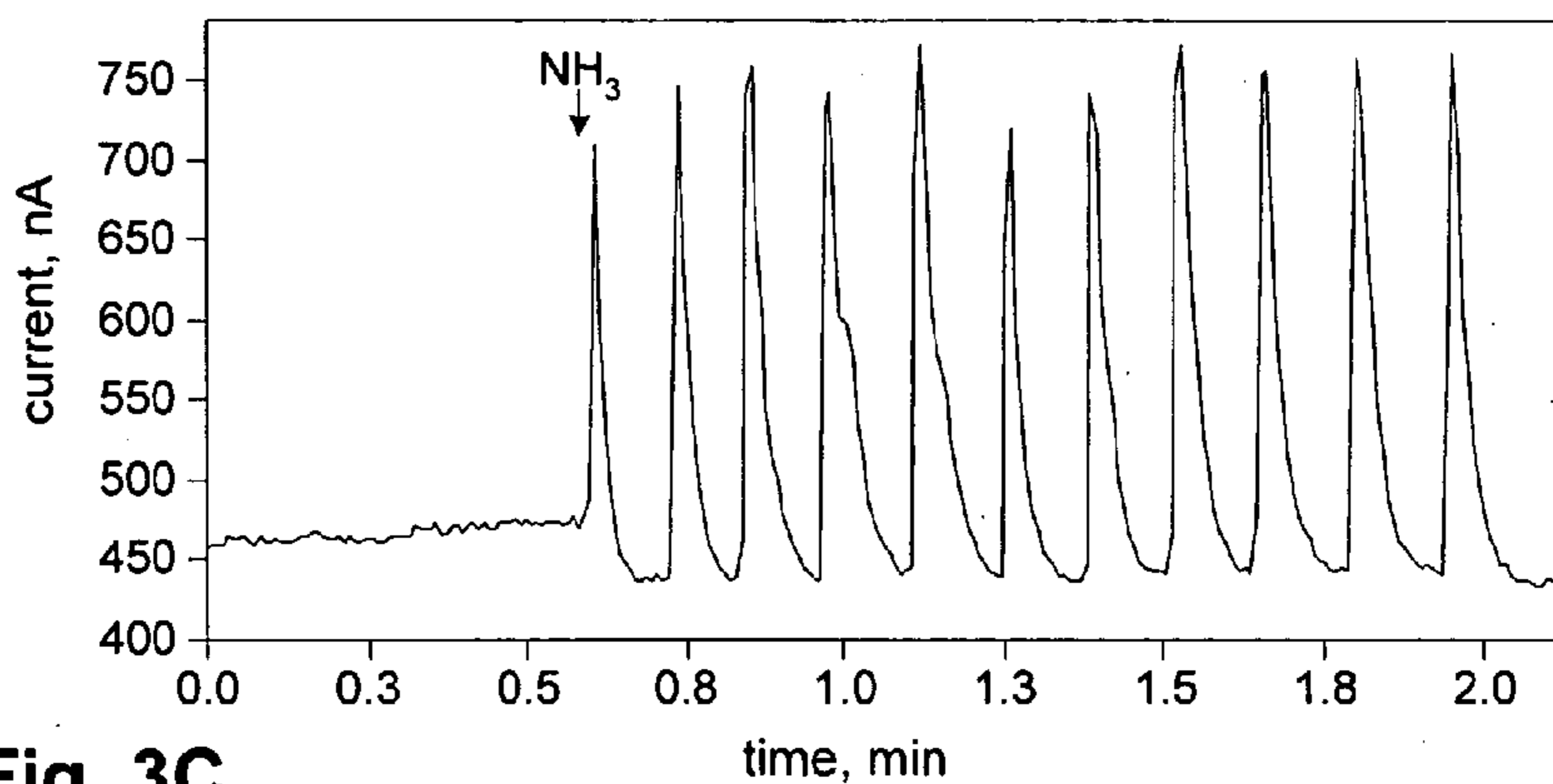

Fig. 3C

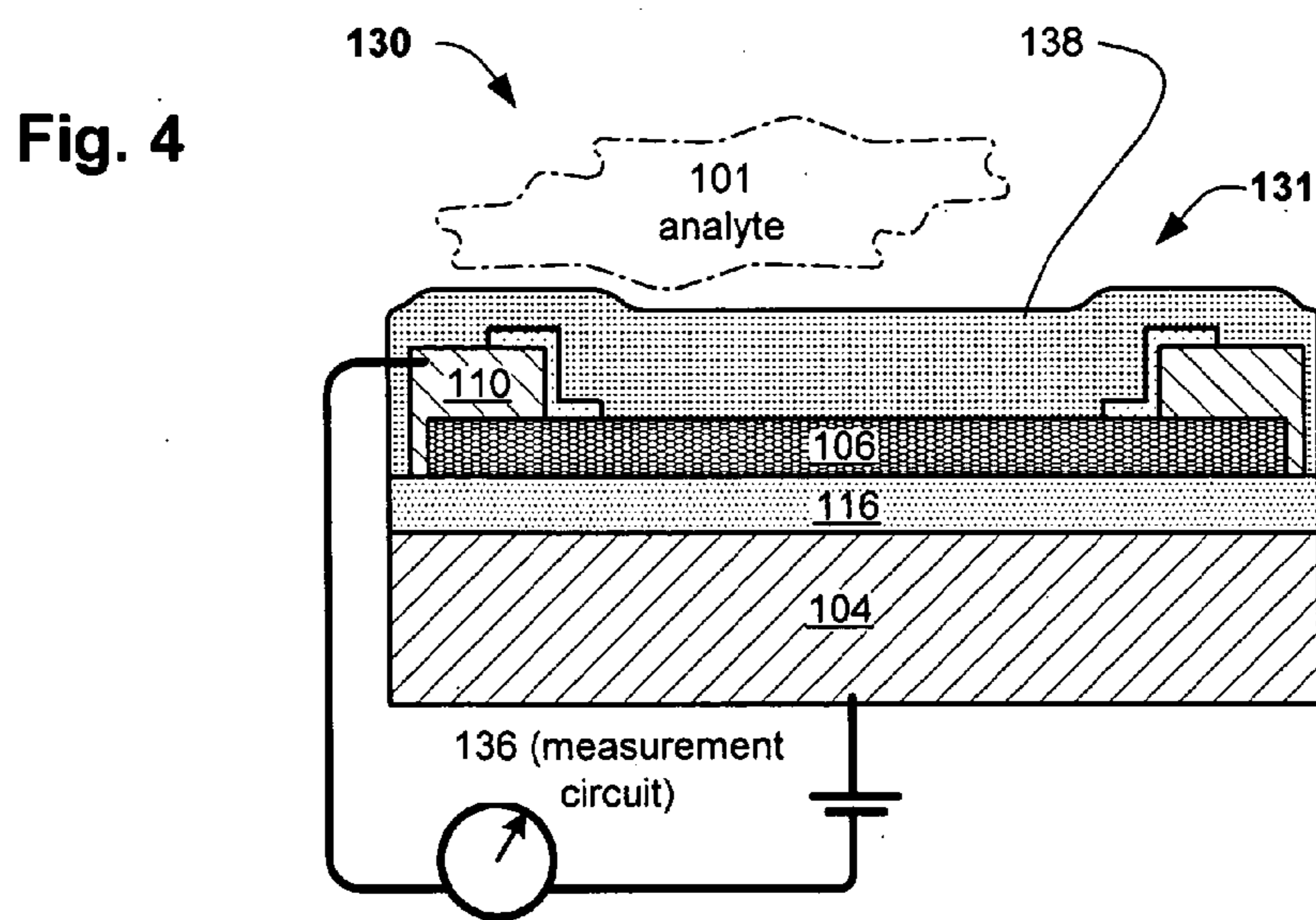

Fig. 4

Fig. 5A - Isoflurane (capcintance & resistance)

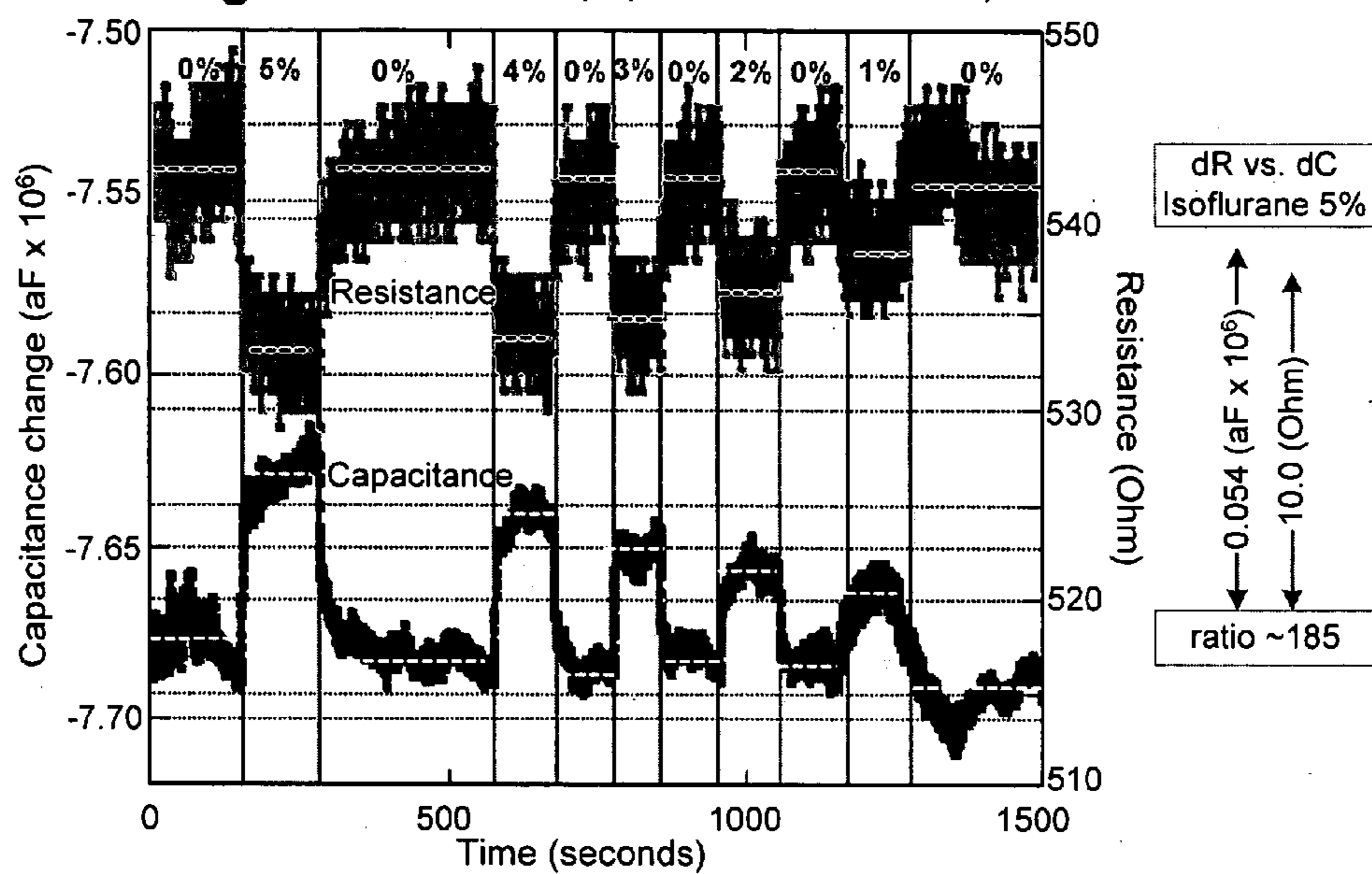
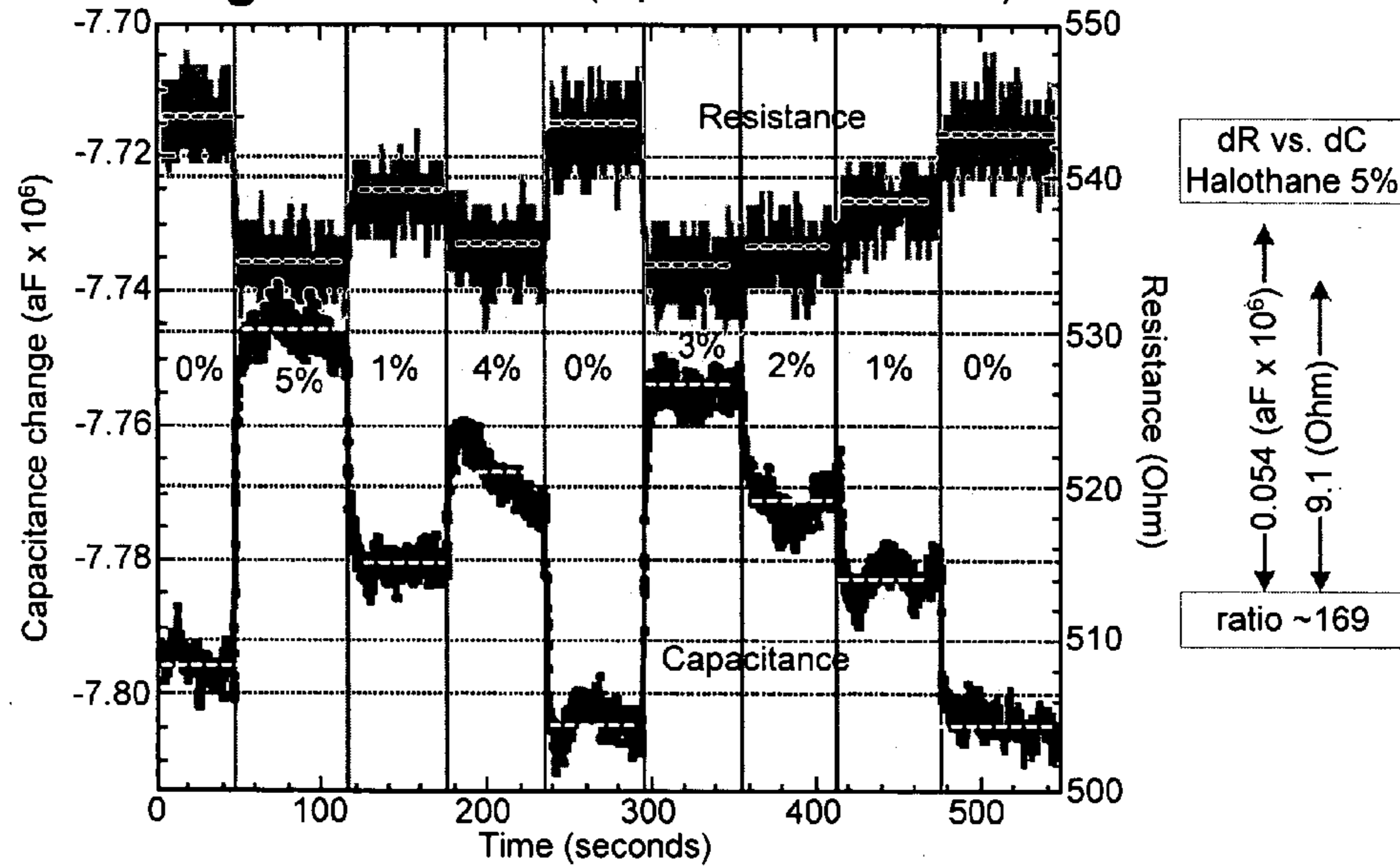

Fig. 5B - Halothane (capcintance & resistance)



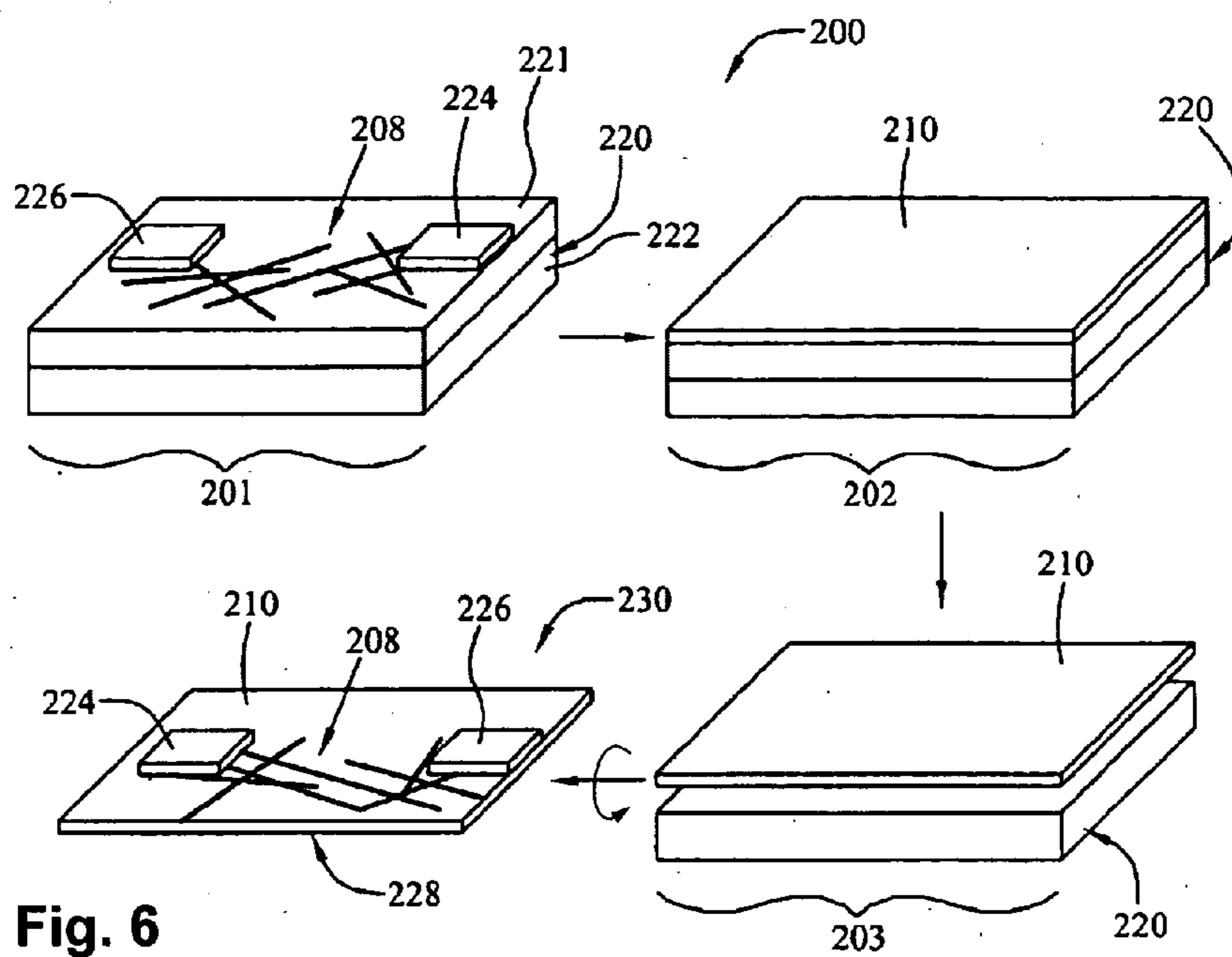

Fig. 6

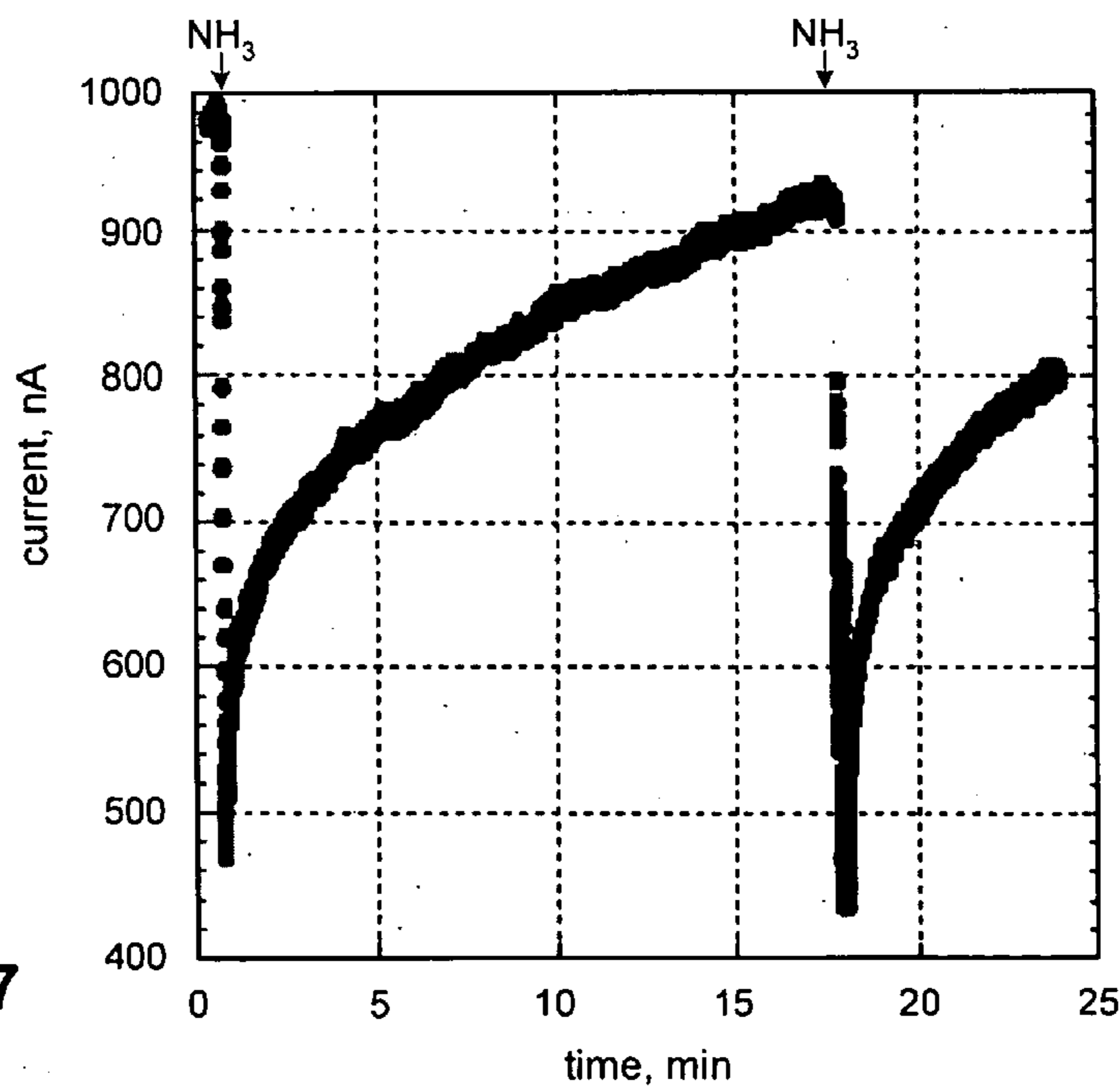

Fig. 7

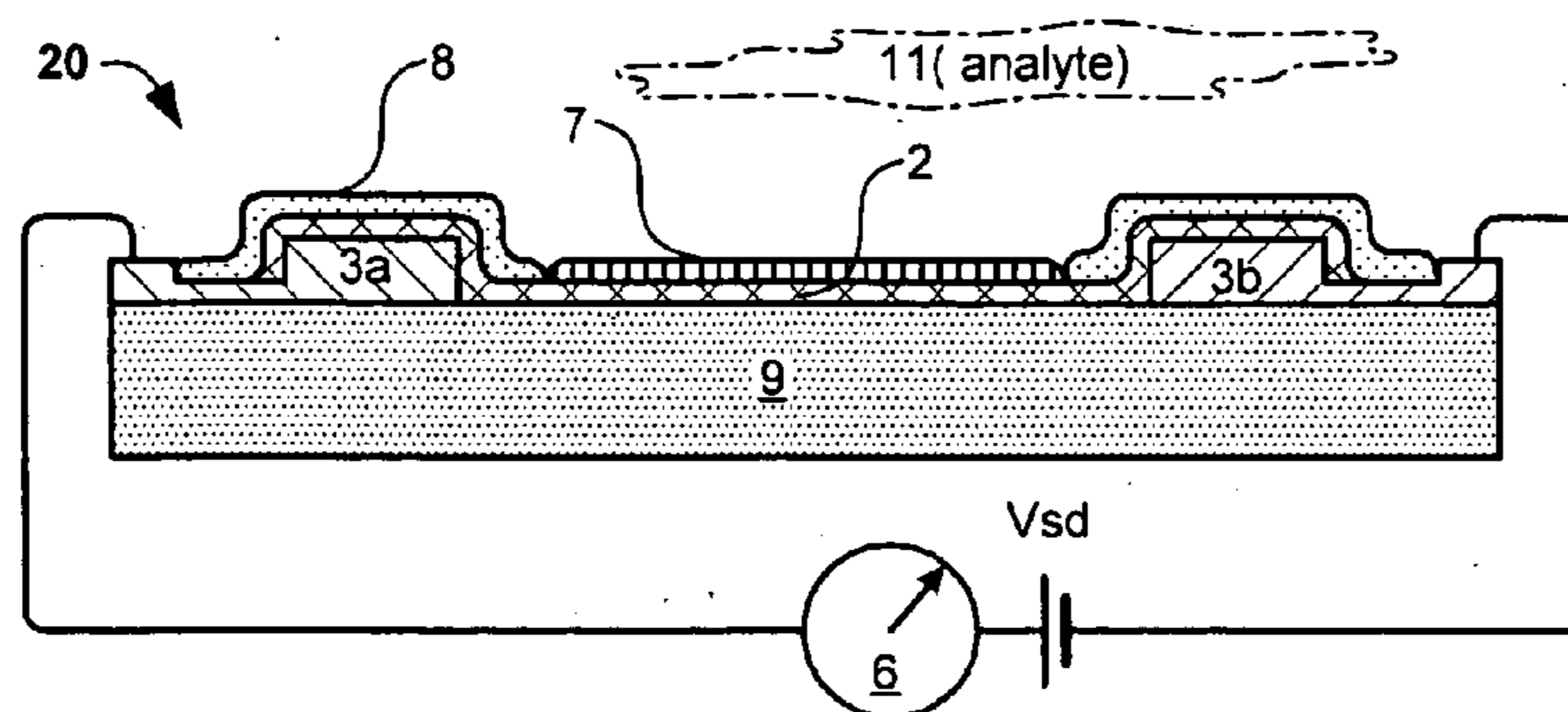

Fig. 8A

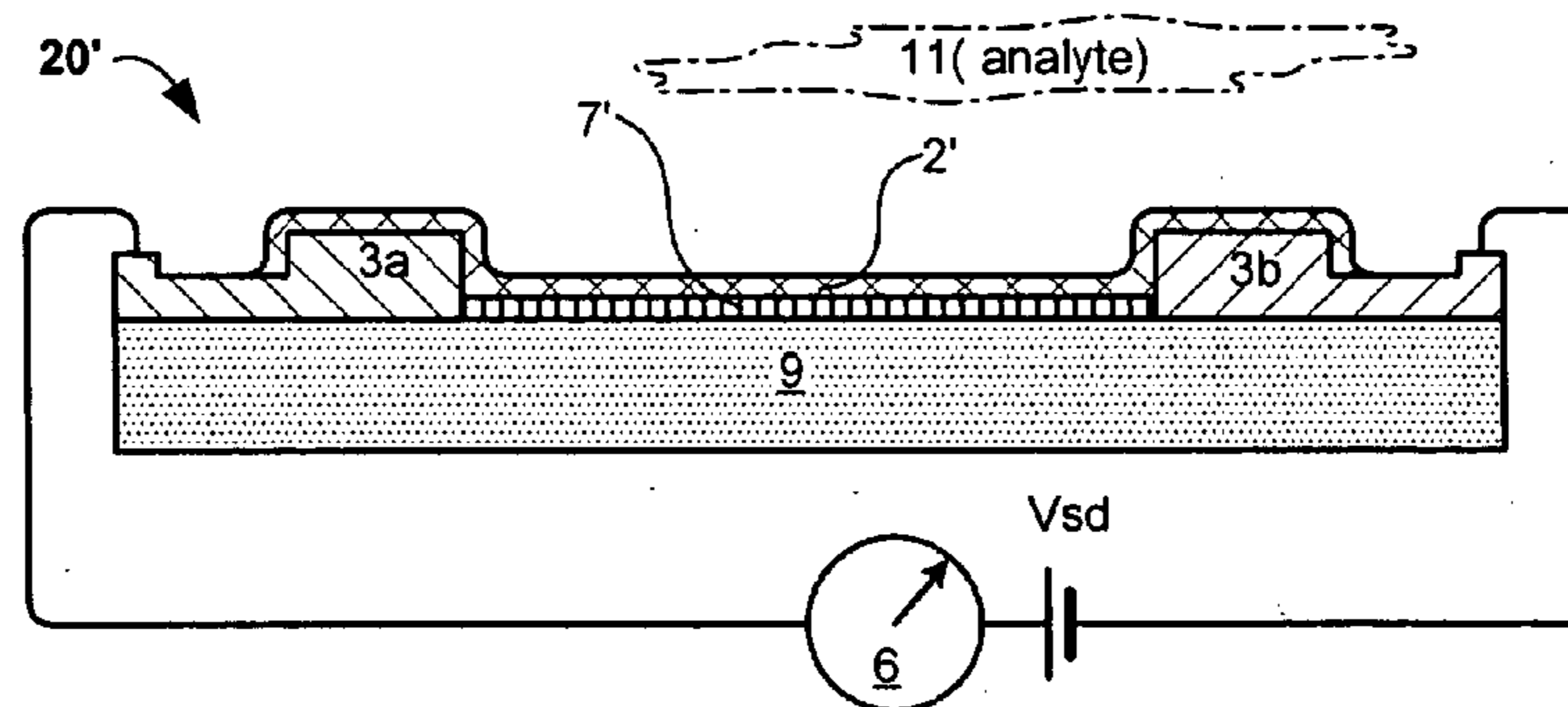

Fig. 8B

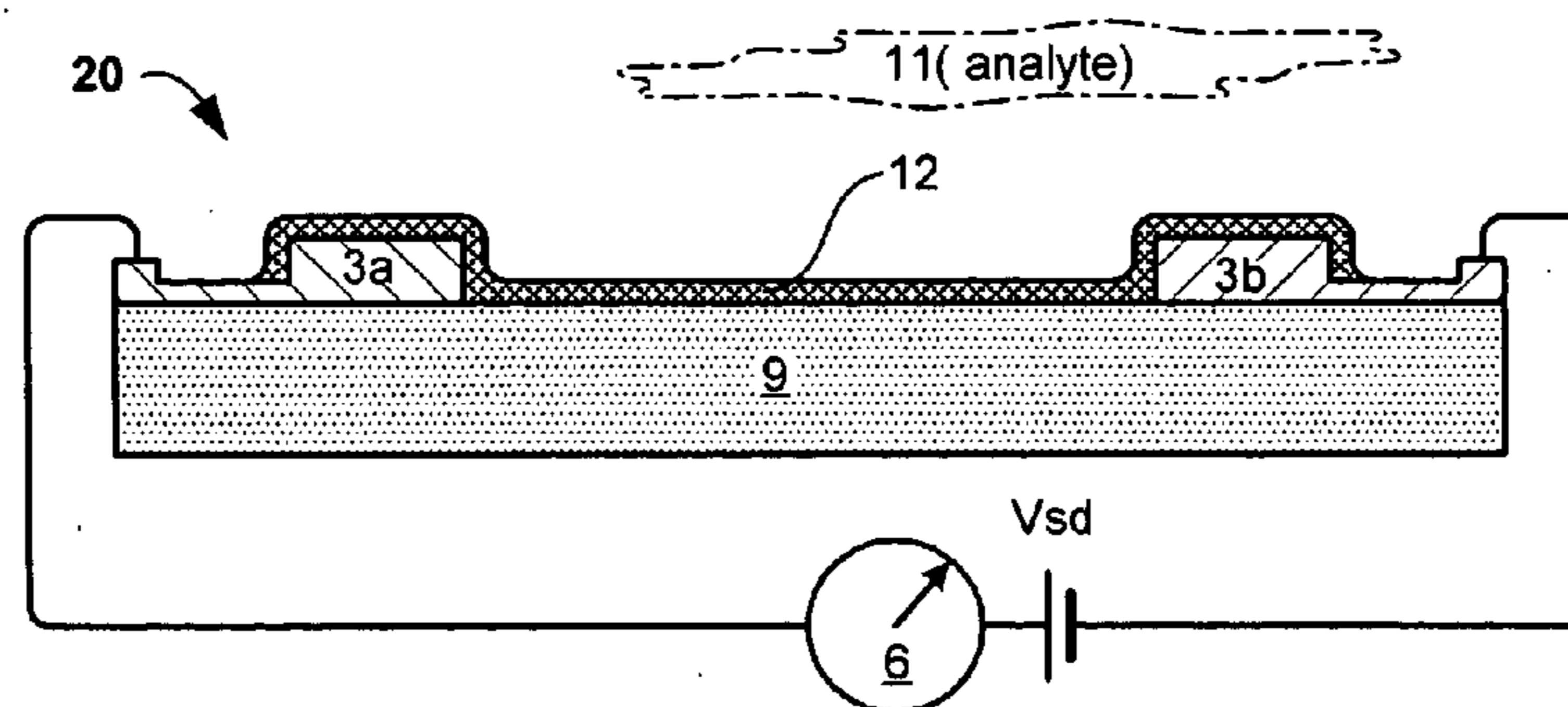

Fig. 8C

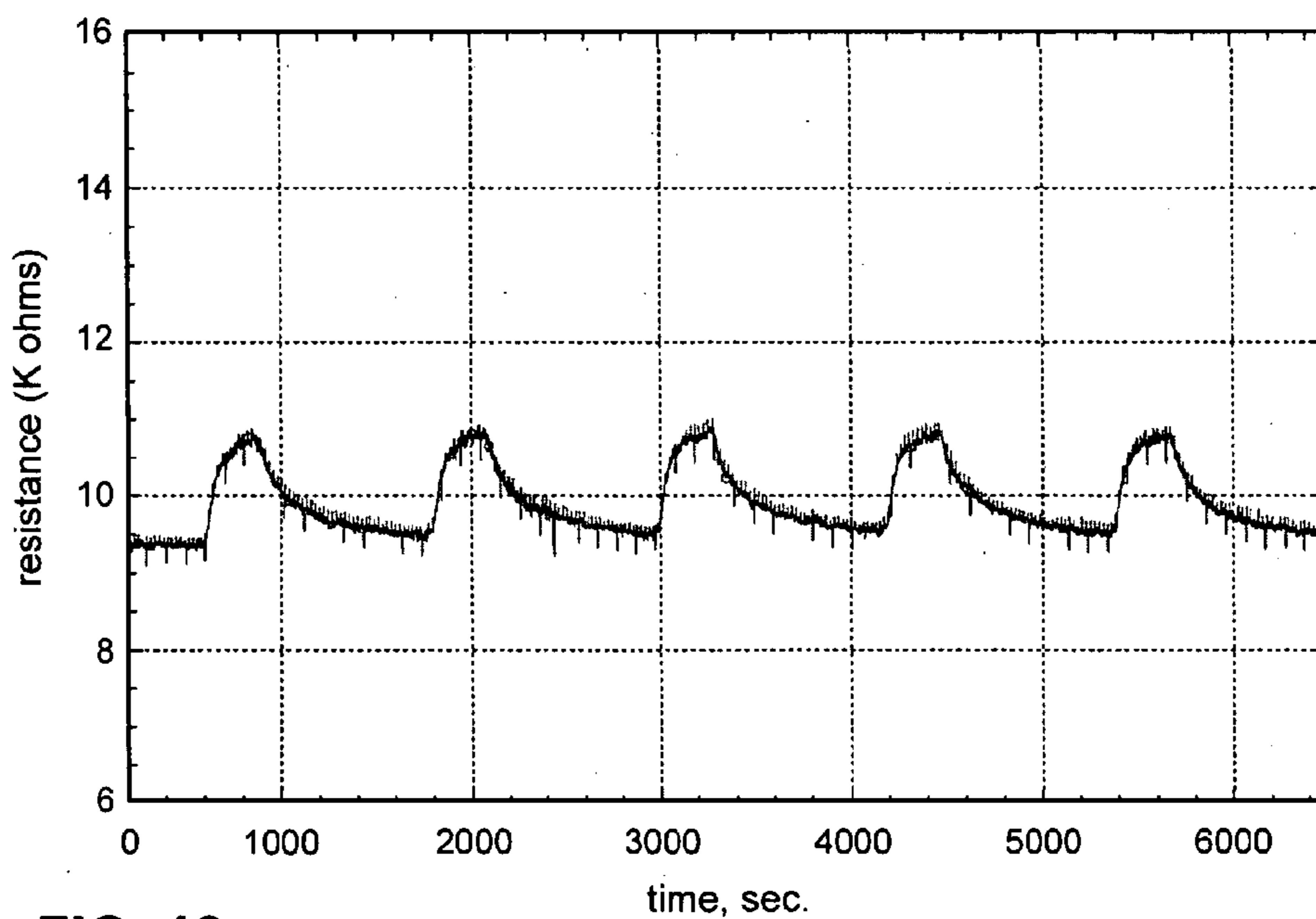
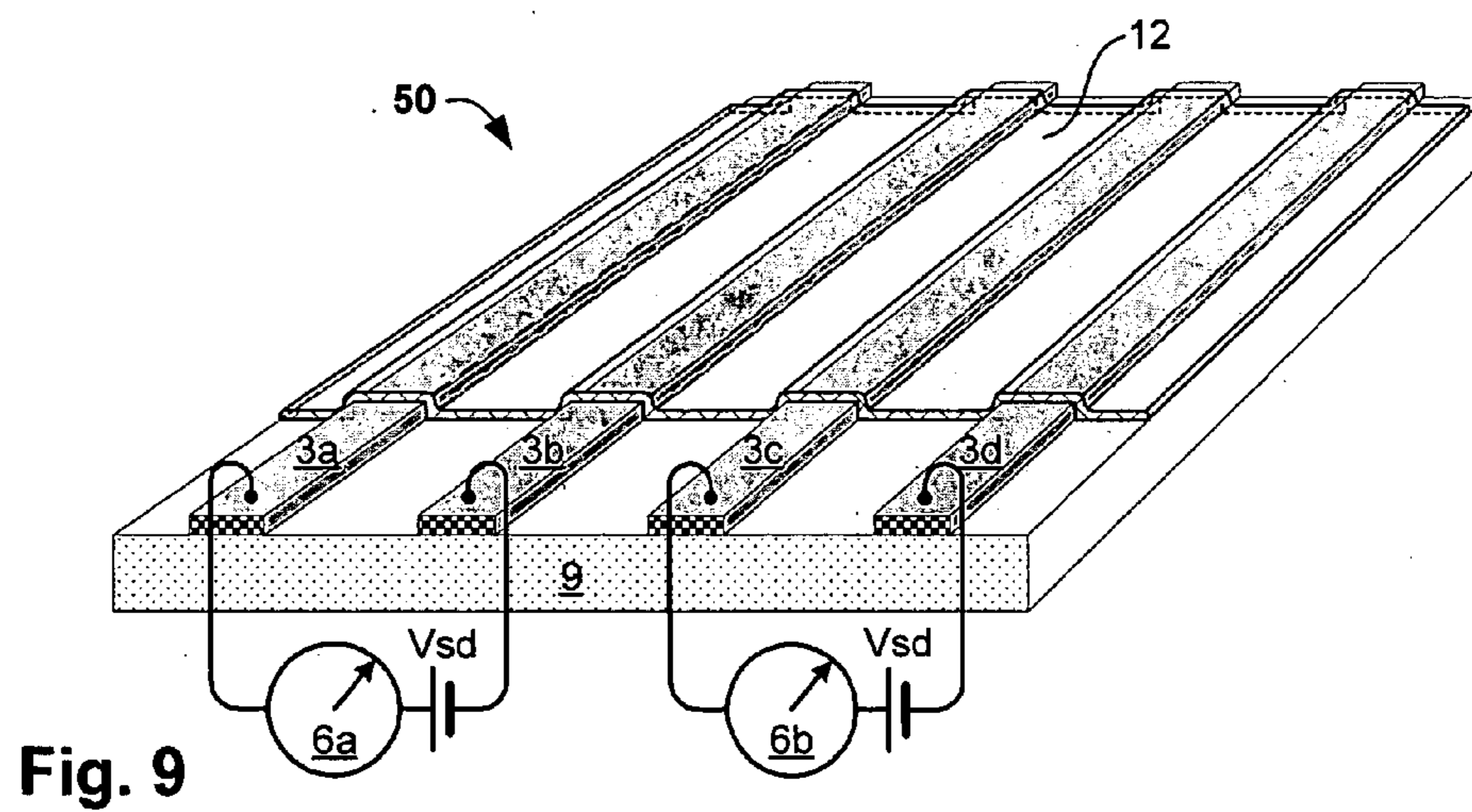

FIG. 10

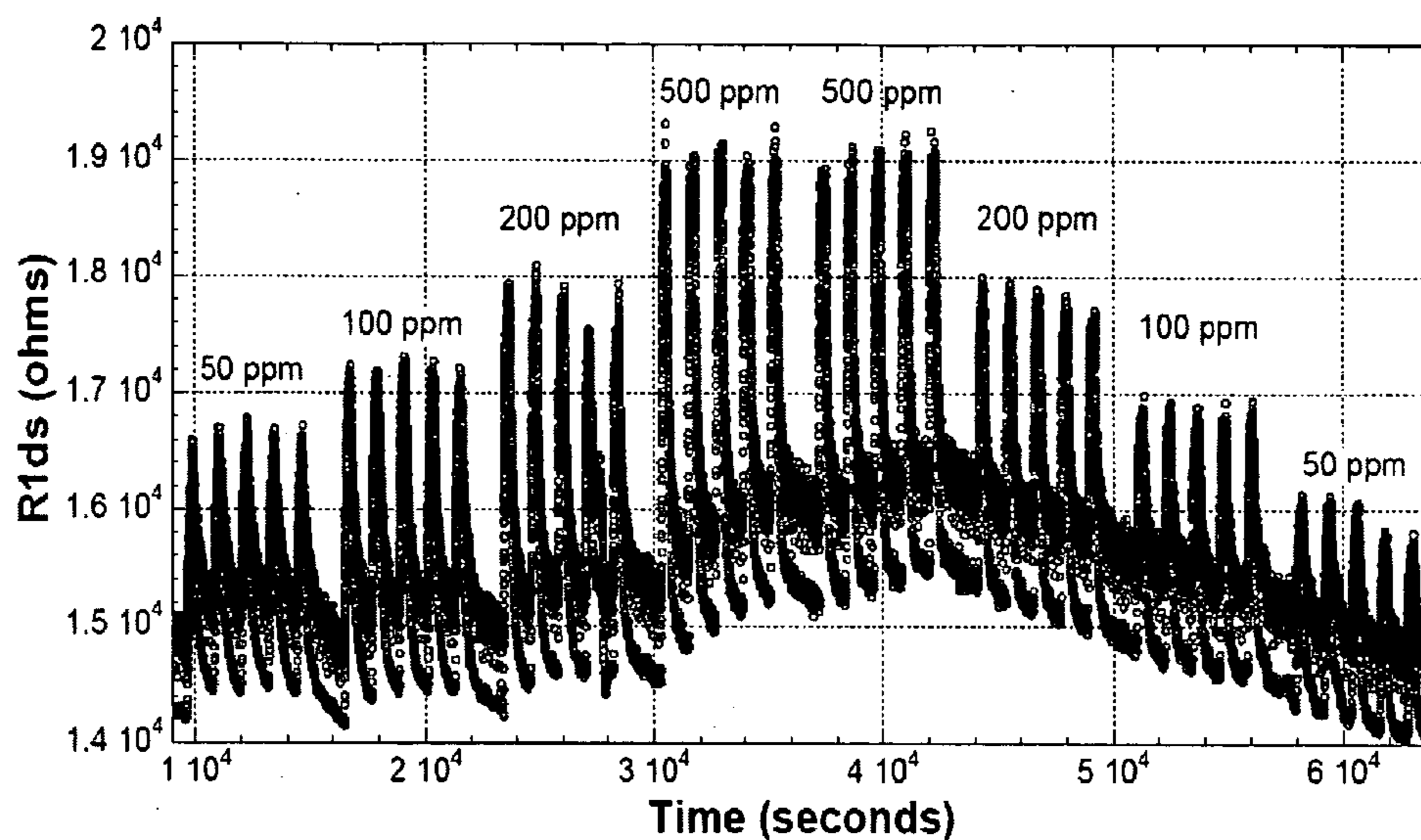

FIG. 11

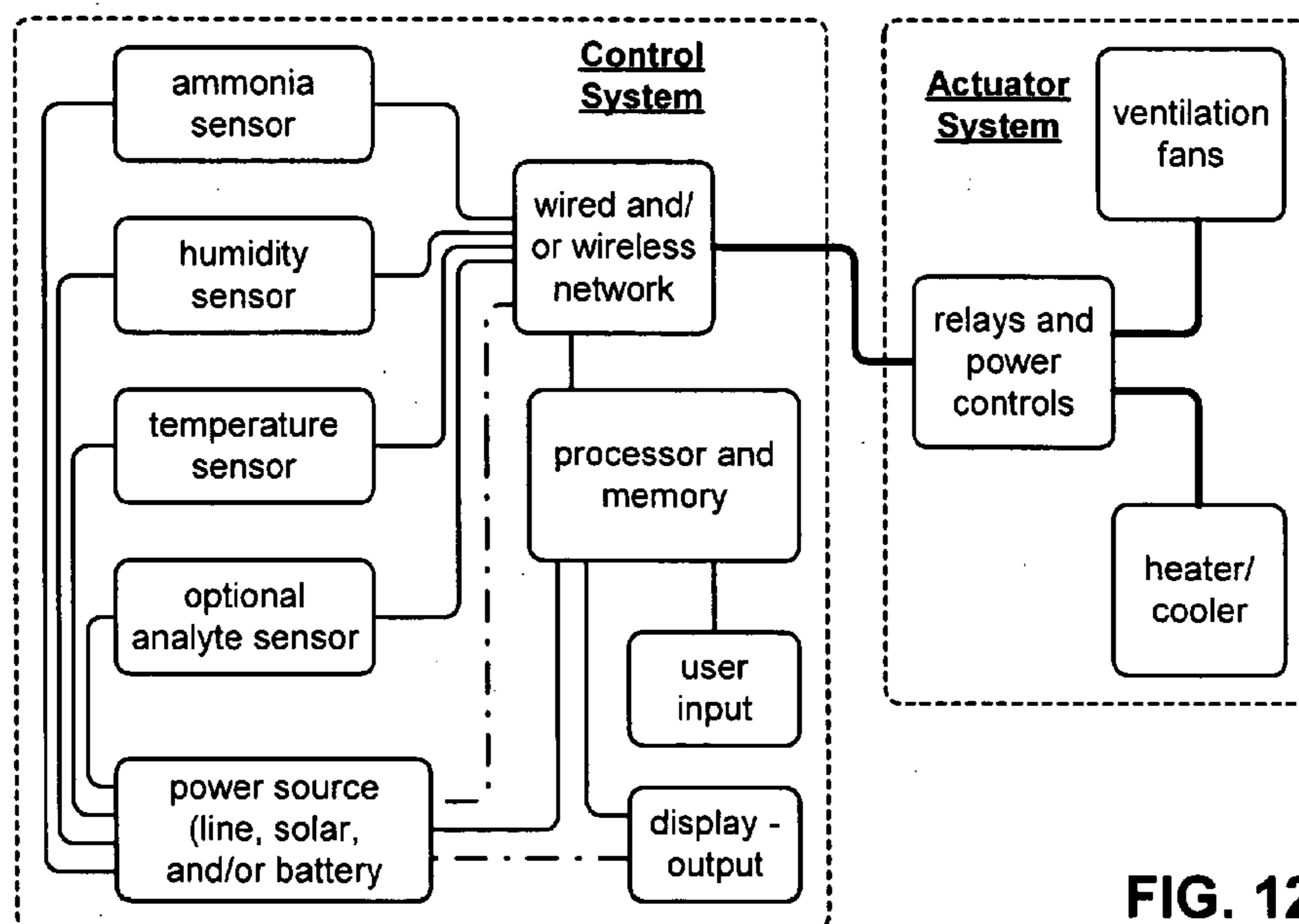
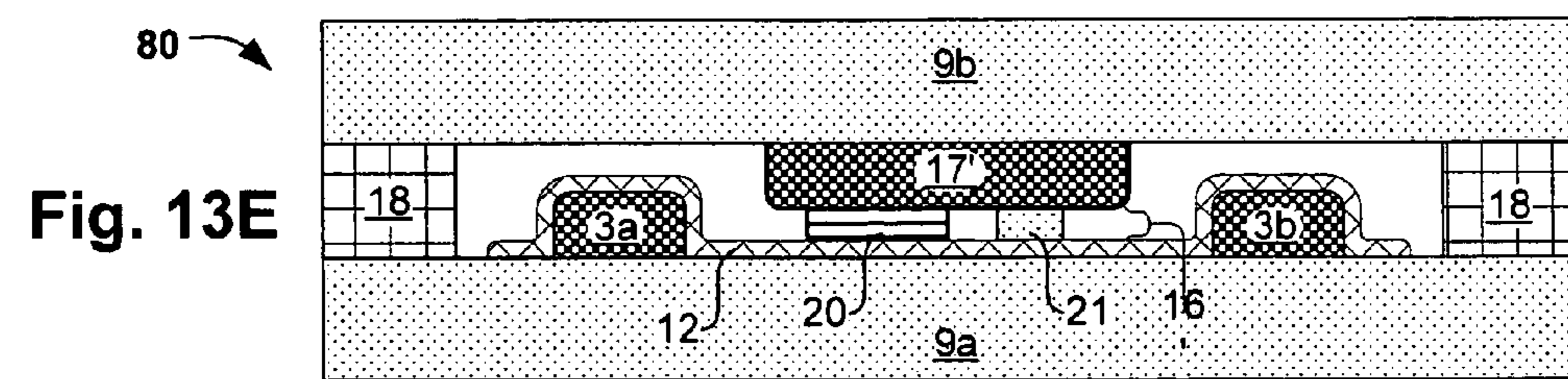
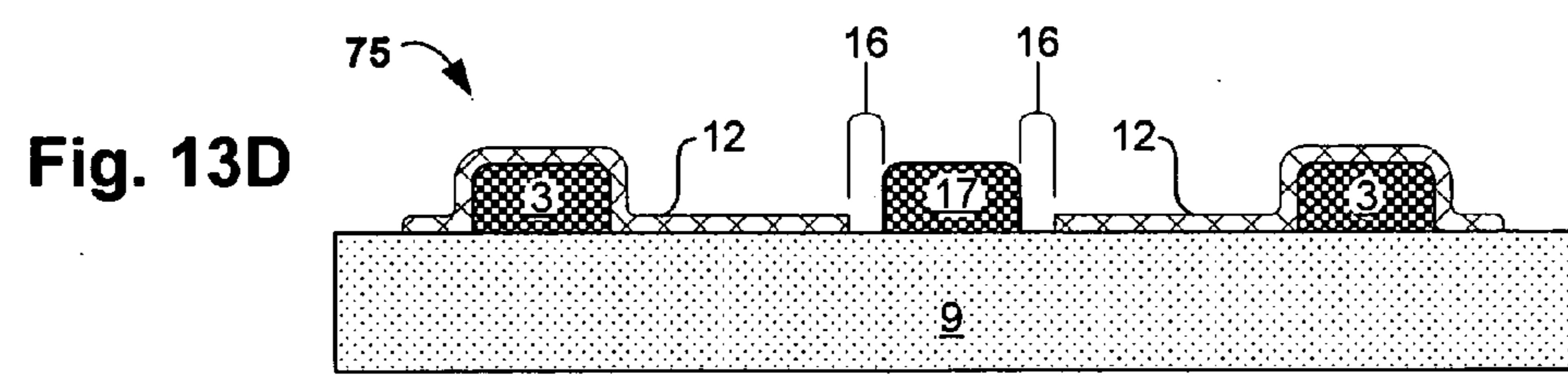
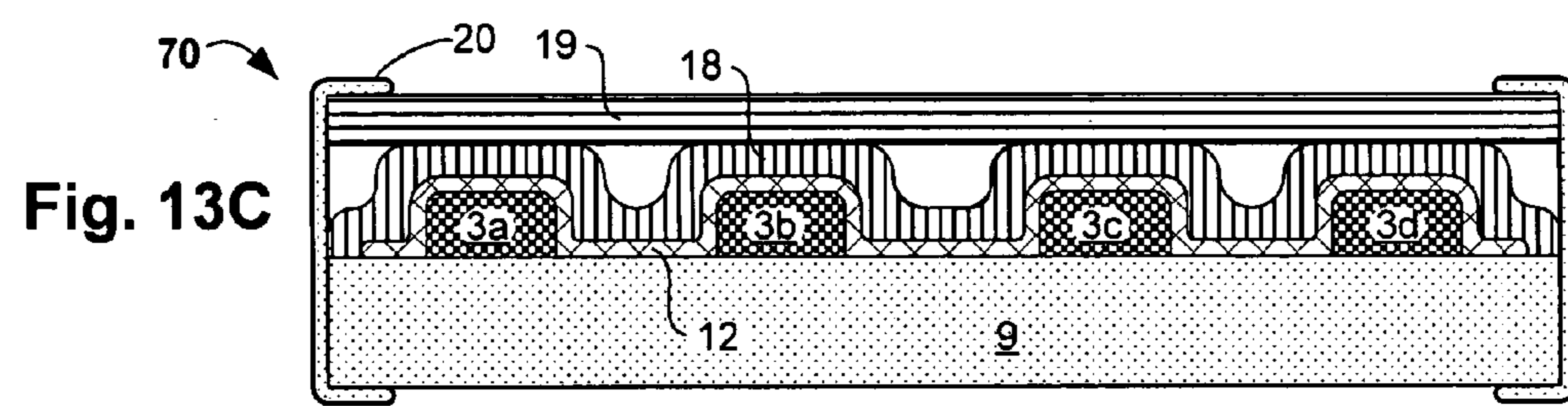
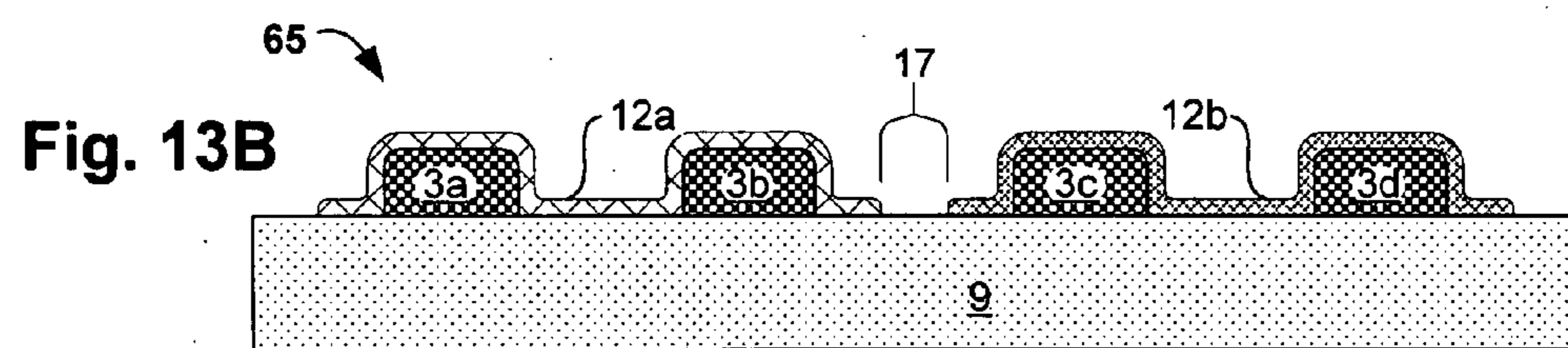
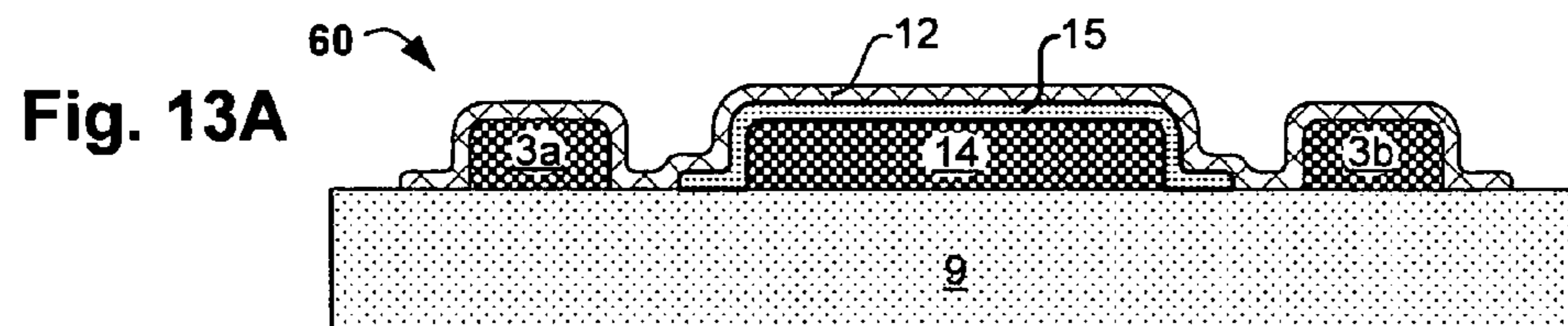

FIG. 12



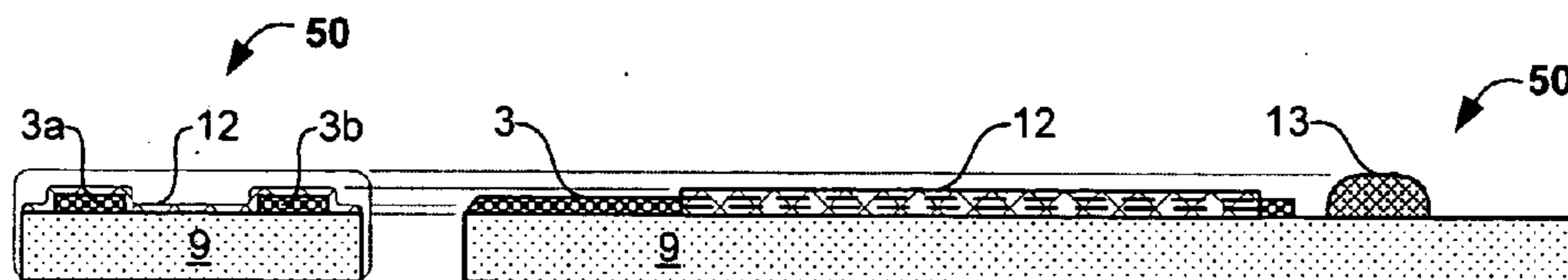

Fig. 14A

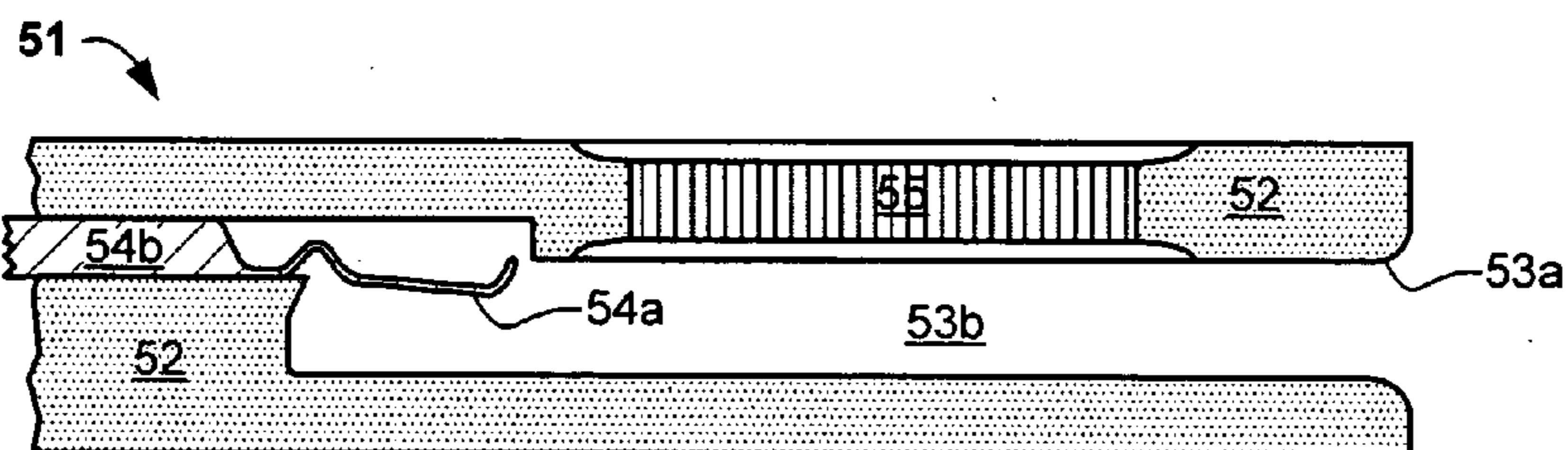

Fig. 14B

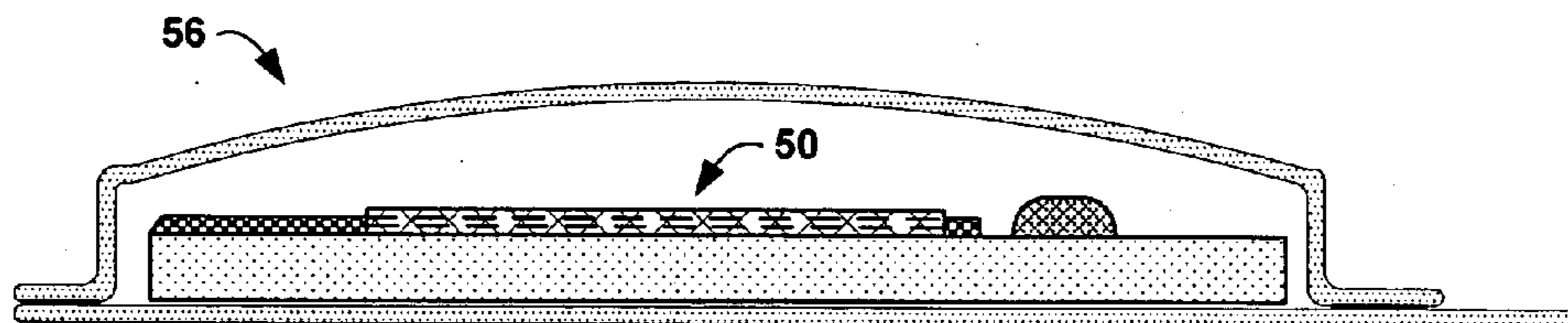

Fig. 14C

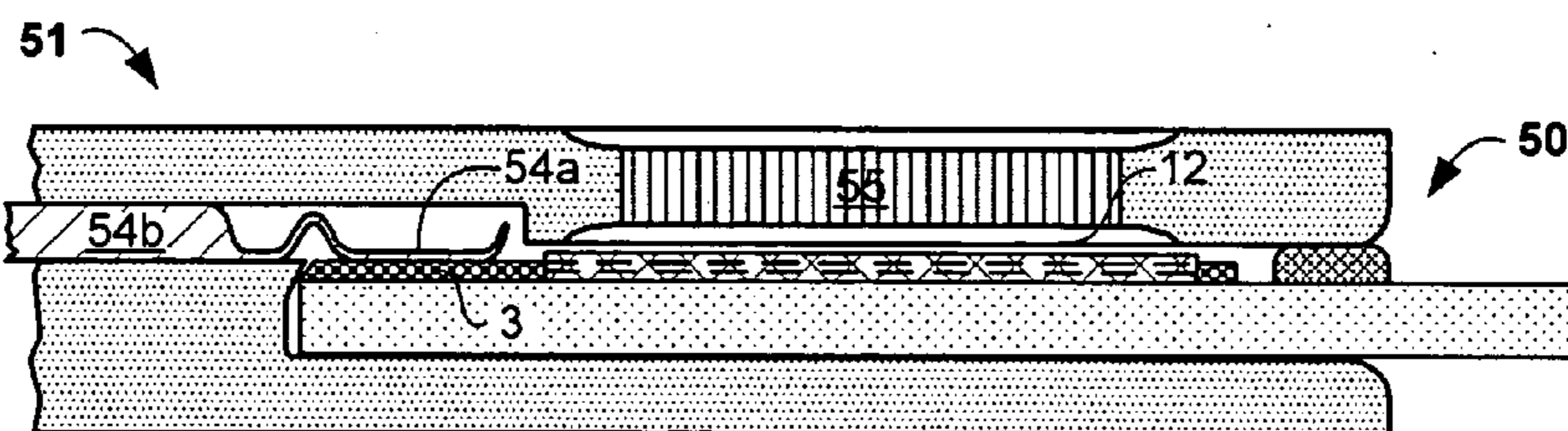

Fig. 14D

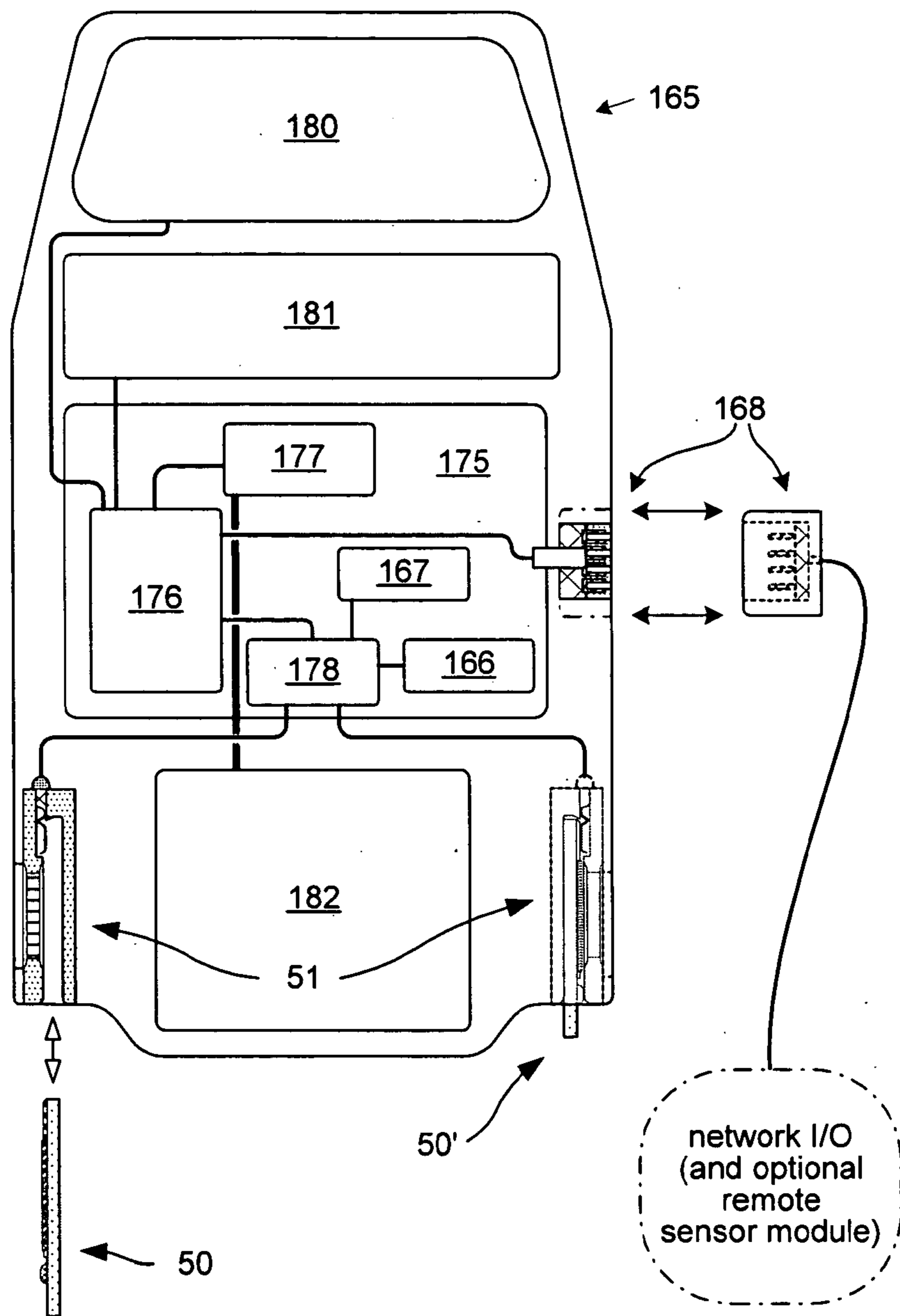

FIG. 15

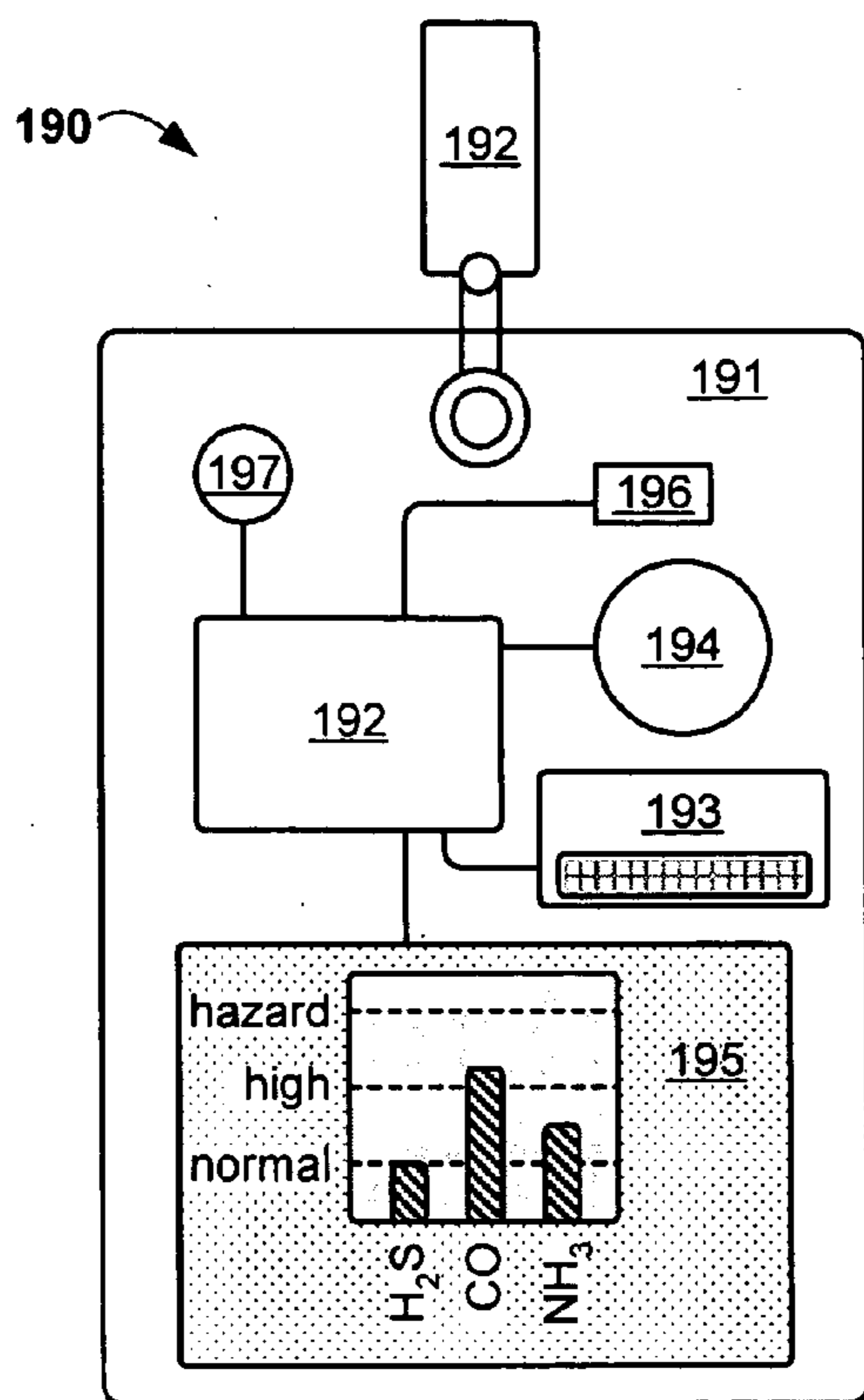

FIG. 16

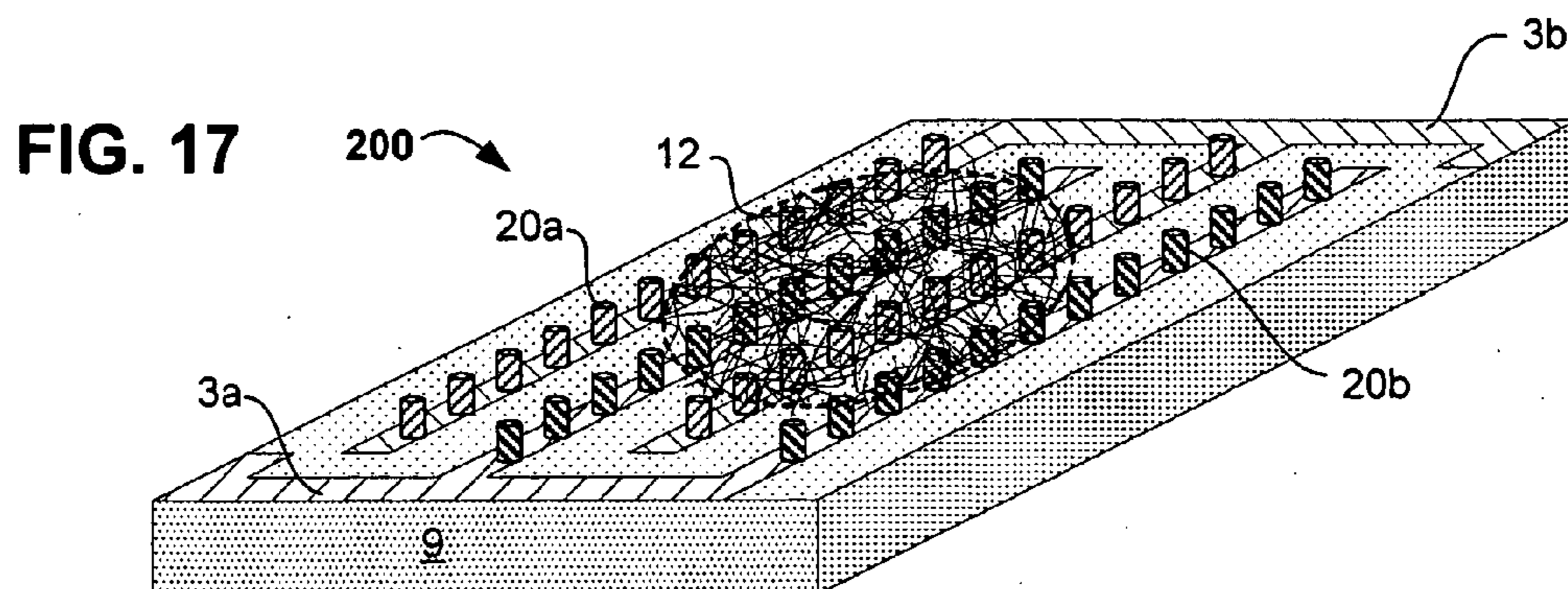

FIG. 17

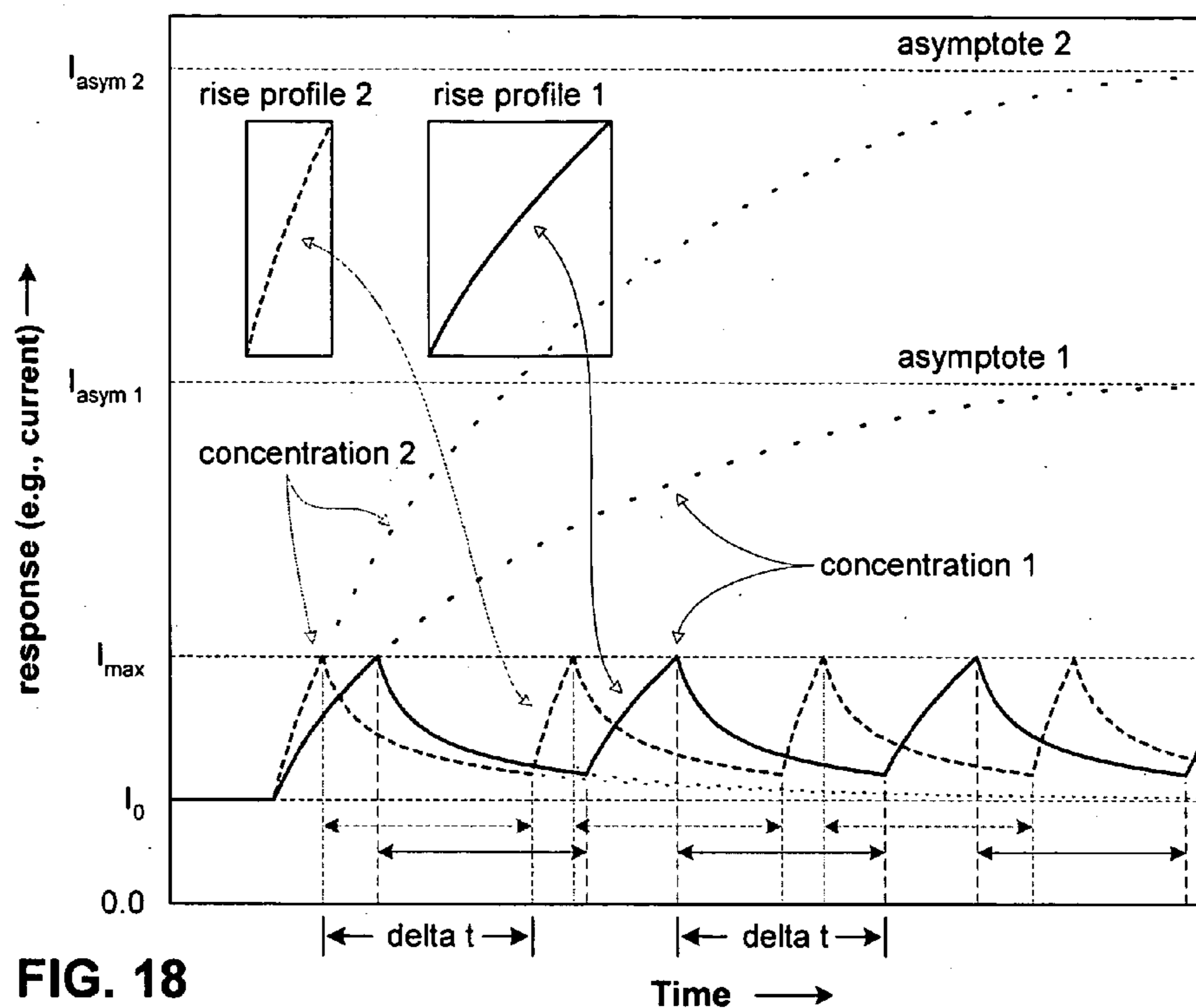

FIG. 18

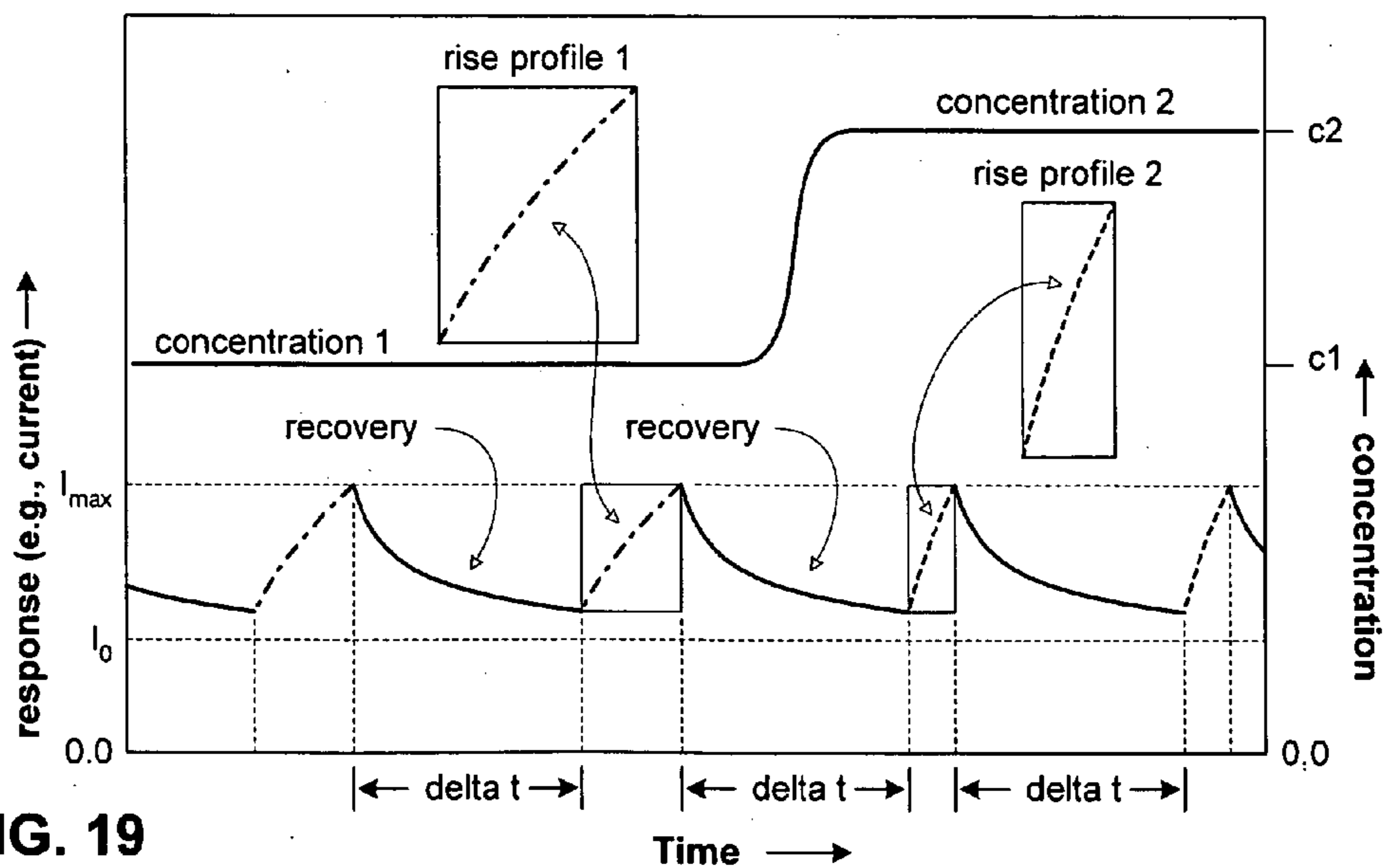

FIG. 19

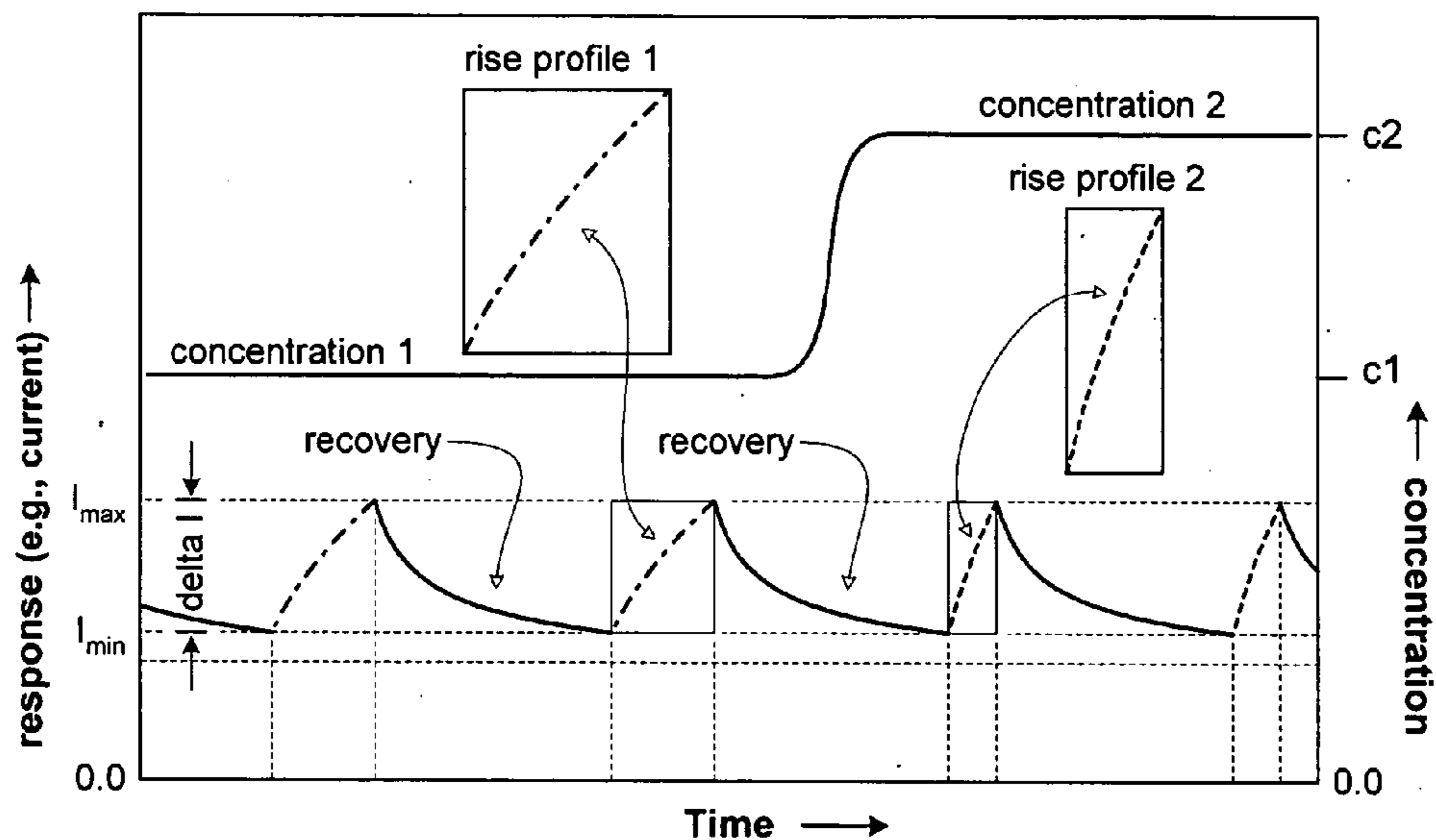

FIG. 20

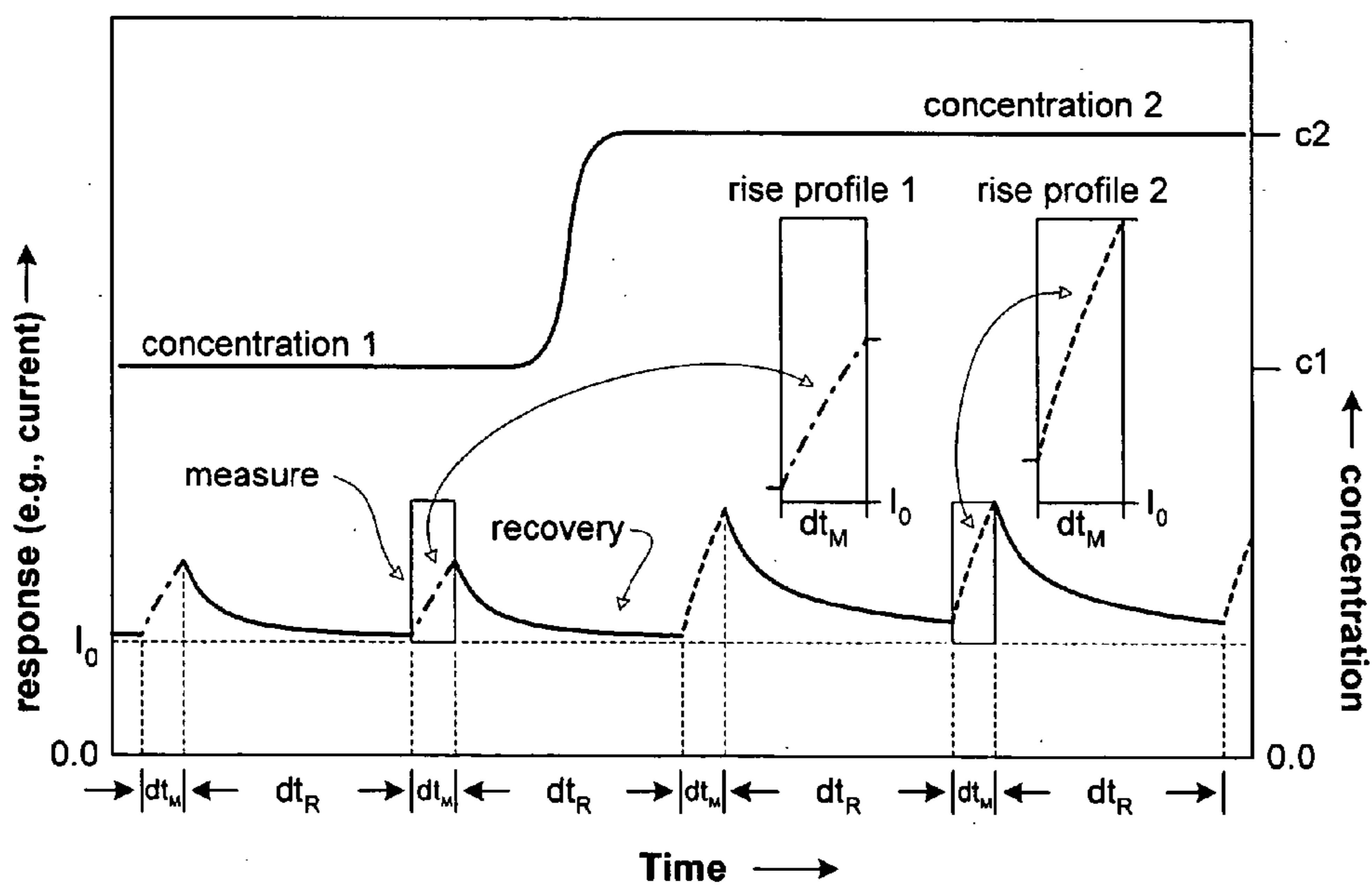

FIG. 21

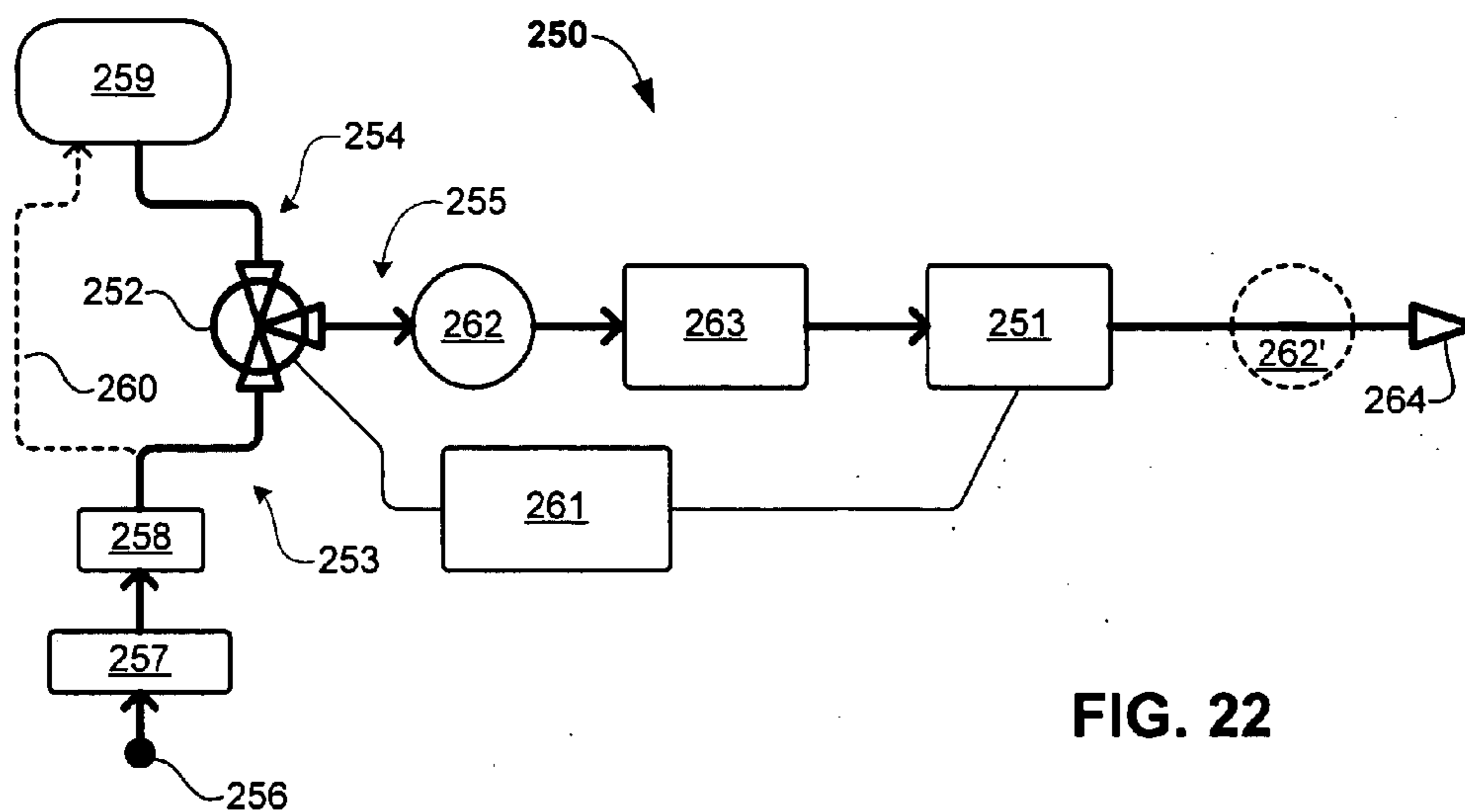

FIG. 22

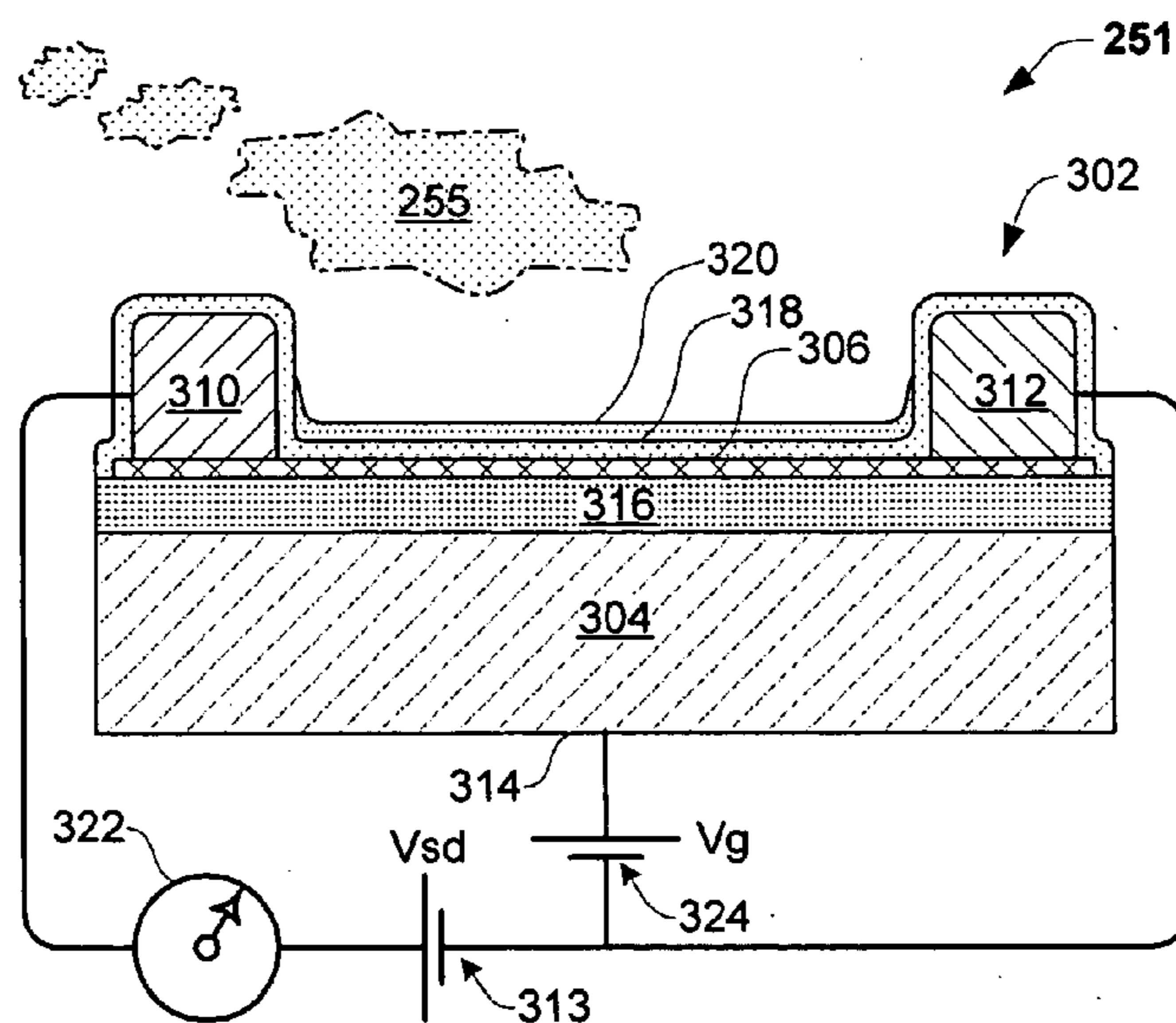

FIG. 23

**AMMONIA NANOSENSORS, AND
ENVIRONMENTAL CONTROL SYSTEM**

CROSS-REFERENCE TO RELATED
APPLICATION

[0001] This application claims priority pursuant to 35 USC. §119(e) to the following US Provisional applications, each of which applications are incorporated by reference:

[0002] No. 60/748,834 filed Dec. 9, 2005 entitled “Nano-electronic Sensors Having Substrates With Pre-Patterned Electrodes, And Environmental Ammonia Control System”.

[0003] This application is a continuation-in-part of and claims priority to U.S. patent application Ser. No. 11/588,845, filed Oct. 26, 2006 (Attorney Docket No. 612,407-098; published 2006-____), entitled “Anesthesia Monitor, Capacitance Nanosensors and Dynamic Sensor Sampling Method”, which is incorporated by reference; and which in turn claims the priority to the following US provisional and non-provisional patent applications, each of which applications are incorporated by reference:

[0004] Ser. No. 11/488,456 filed Jul. 18, 2006 (published 2006-____) entitled “Improved Carbon Dioxide Nanosensor, And Respiratory CO₂ Monitors”, Ser.

[0005] Ser. No. 11/437,275 filed May 18, 2006 (published 2006-____) entitled “Nanoelectronic Breath Analyzer and Asthma Monitor”, Ser.

[0006] Ser. No. 11/390,493 filed Mar. 27, 2006 (published 2006-____) entitled “Nanoelectronic Measurement System For Physiologic Gases, And Improved Nanosensor For Carbon Dioxide”, Ser.

[0007] Ser. No. 11/111,121 filed Apr. 20, 2005 (published 2006-0055,392) entitled “Remotely communicating, battery-powered nanostructure sensor devices”, Ser.

[0008] Ser. No. 11/019,792 filed Dec. 18, 2004 (published 2005-0245,836) entitled “Nanoelectronic capnometer adapter”,

[0009] Ser. No. 10/940,324 filed Sep. 13, 2004 (published 2005-0129,573) entitled “Carbon Dioxide Nanoelectronic Sensor”, Ser.

[0010] Ser. No. 10/656,898 filed Sep. 5, 2003 (published 2005-0279,987) entitled “Polymer Recognition Layers For Nanostructure Sensor Devices”,

[0011] No. 60/730,905 filed Oct. 27, 2005,

[0012] No. 60/850,217 filed Oct. 6, 2006,

[0013] No. 60/773,138 filed Feb. 13, 2006,

[0014] No. 60/700,944 filed Jul. 20, 2005,

[0015] No. 60/683,460 filed May 19, 2005,

[0016] No. 60/665,153 filed Mar. 25, 2005,

[0017] No. 60/564,248, filed Apr. 20, 2004,

[0018] No. 60/531,079 filed Dec. 18, 2003,

[0019] No. 60/502,485 filed Sep. 12, 2003, and

[0020] No. 60/408,547 filed Sep. 5, 2002.

[0021] This application is related in subject matter to U.S. patent application Ser. No. 11/090,550 filed Mar. 25, 2005 entitled “Sensitivity Control For Nanotube Sensors”, which is a divisional of Ser. No. 10/280,265 filed Oct. 26, 2002 (U.S. Pat. No. 6,894,359), which claims priority to U.S. No. 60/408,412 filed Sep. 4, 2002; each of which applications are incorporated by reference.

[0022] This application is related in subject matter to U.S. patent application Ser. No. 10/846,072 filed May 14, 2004 (published 2005-0184,641) entitled “Flexible Nanotube

Transistors”, which claims priority to U.S. No. 60/471,243 filed May 16, 2003; each of which applications are incorporated by reference.

[0023] This application is related in subject matter to U.S. patent application Ser. No. 10/177,929 filed Jun. 21, 2002 entitled “Dispersed Growth Of Nanotubes On A Substrate” (equivalent published as W004-040,671); each of which applications are incorporated by reference.

[0024] This application is related in subject matter to U.S. patent application Ser. No. 11/139,184 filed May 27, 2005 entitled “Modification Of Selectivity For Sensing For Nanostructure Device Arrays”, which is a continuation of Ser. No. 10/388,701 filed Mar. 14, 2003 (U.S. Pat. No. 6,905,655), which claims the priority of U.S. No. 60/366,566 filed Mar. 22, 2002, and which also is a continuation-in-part of U.S. Ser. No. 10/099,664 filed Mar. 15, 2002; each of which applications are incorporated by reference.

BACKGROUND OF THE INVENTION

[0025] 1. Field of the Invention

[0026] The present invention relates to nanoelectronic devices, and in particular to nanostructured sensor systems for measurement of environmental gases, such as ammonia. Nanostructured sensor embodiments having aspects of the invention have utility in industrial, medical, and personal safety applications, including refrigeration leak detection, environmental management of poultry houses, and the like.

[0027] 2. Description of Related Art

[0028] Ammonia has known toxic effects on both humans and animals even at low exposure levels. For example, occupational health regulations typically set upper limits for acceptable ammonia concentrations for human exposure. The limit in the UK is 25 ppm, in Sweden and Germany the limit is 25 and 20, respectively, for an 8-hour working day. Sweden also has a second limit of 50 ppm for a maximum of 5 minutes exposure.

[0029] In addition, ammonia is a common environmental contaminant in poultry houses with important consequences to poultry production. See, for example, I. Estevez, “Ammonia And Poultry Welfare”, Poultry Perspectives, Univ. of Maryland, Spring 2002 volume 4, issue 1, which publication is incorporated by reference.

[0030] Ammonia in poultry houses is difficult to avoid. Uric acid is excreted by poultry and, unless immediately removed, is decomposed by bacteria growing in the warm, moist conditions present in the poultry house litter. Under these conditions, uric acid is readily oxidized (enzymatic oxidative hydrolysis) to form urea as follows:

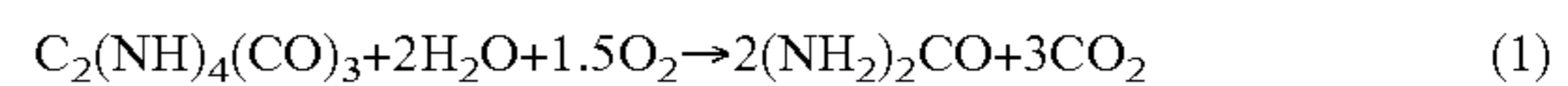

Urea in turn is readily decomposed to form ammonia (hydrolysis by urease) as follows:



The combination of ammonia and wet litter is responsible for a large number of health- and density-related welfare problems in poultry, for example, the occurrence of ascites, gastrointestinal irritation, and respiratory diseases is correlated with high levels of ammonia, as shown in TABLE 1.

TABLE 1

Effect of ammonia levels on poultry health	
Level (ppm)	Effects
10	Trachea irritation, susceptible to bacterial infections.
20	Increased rate of infection by Newcastle disease.
25-75	Impaired growth rate and feed conversion, reduced final body weight.
25-50	Air sac inflammation
50	Increased levels of keratoconjunctivitis.
100	Increased chick mortality.

[0031] In addition to the animal welfare consequences of the pain and stress of ammonia related pathologies, ammonia levels above about 25-50 ppm have an important, affect on growth rate and feed conversion performance. See B. Lott, “*Will ammonia really hurt broiler performance?*”, Chicken Talk, Mississippi State University Extension, Information sheet No. 1639, 2003, which publication is incorporated, by reference. It is believed that ammonia levels have a greater impact than behavioral factors in depressing poultry growth at high rearing densities (TABLE 2).

TABLE 2

Effect of ammonia on average body weight of males at 7 weeks age.		
Ammonia (ppm)	4 weeks (lb)	7 weeks (lb)
0	2.99	6.74
25	2.95	6.55
50	2.41	6.24
75	2.47	6.23

[0032] Note that the effects of ammonia are highly dependent on exposure time. Therefore any effect demonstrated at rather high concentrations is likely to be present at much lower concentrations with longer exposure times. The cumulative effect of reduction in poultry growth and feed conversion due to environmental ammonia is a major economic burden on the poultry industry.

[0033] While ammonia levels may be partially controlled by attention to poultry diet, watering equipment, absorbent litter, and the like, adequate ventilation control is a necessary component of ammonia level management, as well as for temperature and humidity control. U.S. Pat. No. 5,407,129 issued to Carey et al. describes systems and methods for environmental control of poultry houses, and suggests that ammonia sensors may be included in such systems, which patent is incorporated by reference. However, in practice, systems have not been introduced into the poultry industry that use measurement of ammonia as a primary control variable, and instead typically seek to control ammonia indirectly by monitoring and controlling humidity and temperature.

[0034] A variety of different techniques for ammonia sensing are available for sensing ammonia, but generally suffer from one disadvantage or another. Colorimetric indicators or sensing paper do not provide an electronic signal suitable for feedback control systems. Metal-oxide and catalytic metal detectors have generally low selectivity, drift and a high operating temperatures (~400-600 C). Optical gas sensors are generally large, expensive, and slow in response. Conducting polymer detectors have irreversible reactions, limiting their utility.

[0035] Current electrochemical sensors for ammonia have an electrolyte component that is consumed as the sensor is exposed to ammonia, thereby limiting service life, except in very low level exposure. The sensor life rating is thus in terms of “exposure time at concentration”. For example, for a sensor rating of 1000 ppm-day, an exposure to 50 ppm of ammonia (realistic level for poultry houses) for 20 days will completely exhaust the electrolyte.

[0036] What is needed is a low-cost, compact electronic sensor with dependable service life, stable calibration and high selectivity, to provide a practical ammonia sensor for medical, industrial and personal safety applications. In particular, there is a need for such sensors for environmental management of poultry houses and other livestock enclosures.

SUMMARY OF THE INVENTION

[0037] Exemplary embodiments of nanoelectronic sensors having aspects of the invention have a conductive (e.g., semi-conducting) nanostructured element, the nanostructured element comprising a nanostructured material or “nanostructure”. As used herein, the terms “nanostructure” or “nanostructured material” include a particulate or macromolecular entities having at least one dimension less than about 100 nm. The nanostructured material or nanostructure may include single or multiple-wall carbon nanotubes, nanoparticles, nanowires, nanofibers, nanorods, nanospheres, nanohorns or the like, or mixtures of these. Additionally, nanostructures may self-assemble to form composite structures, such as ropes, bundles, or other stable aggregations. Although the principal examples include one or more carbon nanotubes, the nanostructures may comprise boron, boron nitride, and carbon boron nitride, silicon, germanium, gallium nitride, zinc oxide, indium phosphide, molybdenum disulfide, silver, or other suitable materials.

[0038] A preferred nanostructured material for employment in nanoelectronic sensors is the carbon nanotube. Nanotubes were first reported in 1993 by S Iijima and have been, the subject of intense research since. Single walled nanotubes (SWNTs) are characterized by strong covalent bonding, a unique one-dimensional structure, and exceptionally high tensile strength, high resilience, metallic to semiconducting electronic properties, high current carrying capacity, and extreme sensitivity to perturbations caused by charged species in proximity to the nanotube surface. Elements based on nanostructures such carbon nanotubes (CNT) have unique electrical characteristics, and their sensitivity to environmental changes can modulate the surface energies of the CNT, and can measurably change electrical properties, such as resistance, conductivity, transistor characteristics, capacitance or impedance, and the like. Certain exemplary embodiments having aspects of the invention include single-walled carbon nanotubes (SWNTs) as semiconducting or conducting elements.

[0039] Embodiments of sensors may comprise a substrate and a nanostructured element disposed adjacent the substrate. Such nanostructured elements may comprise single or pluralities of discrete parallel elements (e.g. CNTs). For many applications, however, it is advantageous to employ nanostructured elements comprising a film, mat, array or network of semiconducting or conducting nanotubes (or other nanostructures) substantially randomly distributed adjacent a substrate, conductivity being maintained by interconnections between nanotubes. In examples including a substrate con-

figured to have a generally planar form, the nanostructured element may comprise a generally planar layer or coating arranged parallel to the substrate surface. In alternative examples including a substrate configured to have a curved surface shape, such as a rod, or tube-like form, the nanostructured element may comprise a layer or coating arranged to have a similar shape adjacent the substrate.

[0040] One or more conductive elements, contacts or electrodes may be disposed adjacent to the nanostructured element so as to communicate electrically with the nanostructured element.

[0041] Nanostructured materials comprising a nanostructured element may be non-functionalized, or may be functionalized to alter properties. In some embodiments, a nanoelectronic sensor may include a recognition material, layer or coating disposed in association with the nanostructured element, wherein the recognition material may be configured to influence the response of the sensor to an analyte of interest (e.g., increase sensitivity, response rate, or the like) and/or may be configured to influence the response of the sensor to the operating environment (e.g., increase selectivity, reduce interference or contamination, or the like).

[0042] For example, functionalization material reactive with NH_3 may be disposed on a sensor, for example, on a nanotube. Recognition layers that preserve the semi-conductive or conductive properties may be selected from noncovalent materials, for example, polymer coatings. In certain examples, a recognition material may be isolated from the nanostructure by an insulating coating, such as an ALD dielectric material. Gate electrodes, reference electrodes or other counter electrodes may be included, e.g., for transistor measurements or capacitance measurements of sensor properties.

[0043] Certain exemplary embodiments of sensors including nanostructured elements (nanoelectronic sensor or nanosensor) are described in parent application Ser. No. 10/940,324 (published US 2005-0129,573), which is incorporated by reference. Nanosensors having aspects of the invention may be configured for the measurement of analytes, for example ammonia (NH_3) present in environmental air. An NH_3 sensor may be connected to an electrical circuit, which will respond to changes in NH_3 concentration in the ambient sensor environment.

[0044] In certain examples, a single substrate sheet, surface or chip may include a plurality of sensors, capable of one or more analytes. Much of the signal processing may be built into the sensor board, requiring only simple and inexpensive external instrumentation for display and data logging, so as to provide a fully calibrated, packaged gas sensor. Alternative embodiments having aspects of the invention include systems configured to include multiplexed assays on a single sensor platform or chip, microprocessors and/or wireless transceivers, permitting convenient recordation and analysis of measurement histories and/or remote monitoring. The output is digital so electronic filtering and post processing may be used to eliminate extraneous noise, if need be. See, for example, U.S. patent application Ser. No. 11/111,121 filed Apr. 20, 2005 entitled "Remotely communicating, battery-powered nanostructure sensor devices"; which is incorporated by reference.

[0045] Alternative embodiments having aspects of the invention are configured for detection of analytes employing nanostructured sensor elements configured as one or more alternative types of electronic devices, such as capacitive sensors, resistive sensors, impedance sensors, field effect

transistor sensors, and the like, or combinations thereof. Two or more such measurement strategies in a may be included in a sensor device so as to provide orthogonal measurements that increase accuracy and/or sensitivity. Alternative embodiments have functionalization groups or material associated with the nanostructured element so as to provide sensitive, selective analyte response.

[0046] One embodiment of a nanosensor having aspects of the invention comprises: a substrate; a nanostructured element disposed adjacent the substrate; one or more conducting elements in electrical communication with the first nanostructure; and at least one functionalization operatively associated with the nanostructured element, the at least one functionalization configured to provide sensitivity for the analyte of interest. Alternative functionalization materials include a range of organic and inorganic materials. A preferred embodiment includes a network of carbon nanotubes disposed adjacent the substrate and functionalized for sensitivity to ammonia. A number of alternative structures and functionalization schemes are described more particularly in the description below and the claims herein.

[0047] An alternative embodiment of a nanosensor having aspects of the invention comprises: a substrate, the substrate including a generally sheet-like base material and at least one conductor formed on a surface of the substrate; a network of nanostructures deposited on the substrate so as to contact the at least one conductor formation, the network being deposited on the substrate subsequent to the forming of the at least one conductor; and a recognition material disposed in association with the network of nanostructures, the recognition material configured to interact with the analyte of interest. In certain examples, the substrate comprises a flexible polymeric material, and wherein the network of nanostructures includes carbon nanotubes deposited upon the substrate from a liquid suspension. In other examples, a recognition material is associated with the nanotubes prior to the deposition of the nanotubes from liquid suspension. A number of alternative structures and functionalization schemes are described more particularly in the description below and the claims herein.

[0048] An embodiment of an integrated sensor system having aspects of the invention comprises: a nanosensor as described above and configured to expose at least a portion of the network and associated functionalization to a sample, and further comprising a contact in communication with the at least one conducting element, the contact exposed on the sensor surface. The embodiment further comprises a sensor socket, including: a body configured to engage and mount the sensor; at least one pin configured to electrically communicate with at least the contact when the sensor is mounted in the socket, the pin configured to communicate at least one signal to measurement circuitry; and an opening configured to provide that the portion of the network and associated functionalization communicates with the sample. In preferred alternatives the sensor is functionalized for sensitivity to ammonia and may be disposable. A number of alternative structures and functionalization schemes are described more particularly in the description below and the claims herein.

[0049] One embodiment of a control system for regulating the internal environment having aspects of the invention comprises a sensor as described above; and a processor in communication with the sensor so as to receive at least one signal indicative of a concentration of the analyte of interest, the processor configured to send at least a command signal to an environmental actuator in response to the at least one signal,

the command suited to cause the environmental actuator to control the concentration of the analyte of interest in the enclosed volume. In preferred alternatives the sensor is functionalized for sensitivity to ammonia and may be disposable. A number of alternative structures and functionalization schemes are described more particularly in the description below and the claims herein.

[0050] One embodiment of a personnel safety badge having aspects of the invention comprises: a badge body, configured to be worn by the user; a sensor as described above disposed adjacent to the body and configured to measure the analyte of interest; a processor disposed adjacent to the body and in communication with the sensor so as to receive at least one signal indicative of a concentration of the analyte of interest; a power source disposed adjacent to the body and in communication with the processor; and at least one warning output device disposed adjacent to the body, in communication with the processor, and produce at least one communication to the user in response to a concentration of the analyte of interest in the environment of a user.

[0051] One method embodiment for dynamic sensor operation having aspects of the invention comprises: (a) selectively exposing at least a portion of a sensor to the environment so that the sensor portion is exposed only intermittently; and (b) dynamically sampling a response signal output from the sensor so as to determine the presence or concentration of the analyte of by analysis of the dynamically sampled signal. A number of alternative operational steps are described more particularly in the description below and the claims herein.

BRIEF DESCRIPTION OF THE DRAWINGS

[0052] The following is a list which summarizes the drawings and figures herein:

[0053] FIG. 1 is a cross-sectional diagram which illustrates an exemplary electronic sensing device for detecting an analyte, configured in this example as a NTFET.

[0054] FIG. 2 are photographic views of a sensor system such as shown in FIG. 1, wherein views (a-c) include SEM images showing (a) showing the layout of interdigitated source and drain contacts S, D, (b) showing an enlarged detail of a nanotube network N and the contacts S, D, and (c) showing an enlarged detail of the margin of network N. View (d) shows an example of a sensor device mounted in a conventional electronic device package.

[0055] FIG. 3A shows the device characteristics for a transistor device (NTFET) embodiment without additional functionalization (bare nanotubes) to a pulse of 200 ppm ammonia.

[0056] FIG. 3B shows exemplary response of a nanotube device that is not coated with a recognition layer to fluctuating levels of NH₃ in a test environment.

[0057] FIG. 3C shows exemplary improved response of a nanotube device coated with a PEI recognition layer to NH₃ in the same test environment.

[0058] FIG. 4 is a cross-sectional diagram which illustrates an exemplary electronic sensing device, similar in a number of respects to the device of FIG. 1, configured in this example configured for measurement of capacitance and related properties as a signal for detecting an analyte.

[0059] FIG. 5A shows the response of both capacitance signals and resistance signals to samples of isoflurane in air.

[0060] FIG. 5B shows the response of both capacitance signals and resistance signals to samples of halothane in air.

[0061] FIG. 6 is a flow diagram showing exemplary steps of a method according to the invention for producing a device including a CVD deposited CNT network and having a polymer substrate;

[0062] FIG. 7 is a plot showing the response to ammonia of the sensor of FIG. 6.

[0063] FIGS. 8A-8C illustrate alternative embodiments of sensors having solution deposited nanotube networks, wherein:

[0064] FIG. 8A shows a sensor in which a recognition layer is applied following deposition of nanotube film;

[0065] FIG. 8B shows a sensor in which a layer of recognition material is deposited upon the substrate prior to application of a nanotube film 2; and

[0066] FIG. 8C shows a sensor which includes a layer of pre-functionalized nanotubes without a distinct recognition layer.

[0067] FIG. 9 shows an exemplary embodiment of a sensor device 50 having aspects of the invention and including a nanotube networks fabricated by deposition of a solution of pre-functionalized nanotubes upon a substrate.

[0068] FIG. 10 shows the response of the sensor of FIG. 8 to repeated exposures of 50 ppm of ammonia.

[0069] FIG. 11 shows the response of the sensor of FIG. 8 to ammonia exposures through a dynamic range spanning 50 ppm to 500 ppm.

[0070] FIG. 12 is a schematic layout diagram of an exemplary environmental control system including a nanoelectronic ammonia sensor having aspects of the invention.

[0071] FIGS. 13A-13E illustrate alternative embodiments of sensors having aspects of the invention and including nanotube networks fabricated by deposition of a solution upon flexible substrates with pre-patterned conductor traces, wherein:

[0072] FIG. 13A shows an alternative sensor including a gate dielectric and gate electrode;

[0073] FIG. 13B shows a sensor including a plurality of distinct pairs of pre-patterned traces having differently functionalized nanotube networks;

[0074] FIG. 13C shows a sensor generally similar to that shown in FIG. 9, and having additional layers for conditioning the sample;

[0075] FIG. 13D shows a sensor configured as a capacitance sensor; and

[0076] FIG. 13E shows alternative embodiment of a capacitance sensor.

[0077] FIGS. 14A-14D illustrate an exemplary embodiment of a sensor system having aspects of the invention, wherein:

[0078] FIG. 14A shows a sensor generally similar to the embodiment of FIG. 9 configured as a disposable sensor;

[0079] FIG. 14B shows a sensor mounting socket suitable for the sensor of FIG. 14A;

[0080] FIG. 14C shows the sensor of FIG. 14A as sealed in a "blister pack" package; and

[0081] FIG. 14D shows the sensor of FIG. 14A as mounted in the socket of FIG. 14C.

[0082] FIG. 15 shows an exemplary embodiment of a control system employing the disposable sensor and socket of FIGS. 14A-14D.

[0083] FIG. 16 shows an exemplary embodiment of a personnel safety badge having aspects of the invention.

[0084] FIG. 17 shows an exemplary embodiment of a sensor having a network suspended apart from a substrate.

[0085] FIG. 18 is a schematic plot illustrating principles of a dynamic sensor sampling method having aspects of the invention.

[0086] FIG. 19 is a schematic plot an example of dynamic sensor sampling for a step change in analyte concentration, having a fixed response cut-off values and recovery interval.

[0087] FIG. 20 is a schematic plot an example of dynamic sensor sampling for a step change in analyte concentration, having both fixed maximum and minimum values.

[0088] FIG. 21 is a schematic plot an example of dynamic sensor sampling for a step change in analyte concentration, having a both fixed measurement and recovery intervals.

[0089] FIG. 22 is a schematic diagram of an exemplary sensor system configured for employing a dynamic sampling method.

[0090] FIG. 23 illustrates the structure of a sensor adapted for measuring NH₃, for example in a system such as is shown in FIG. 22.

DETAILED DESCRIPTION OF THE PREFERRED EMBODIMENT

A. Exemplary Nanosensor Architecture

[0091] FIG. 1. shows an exemplary electronic sensing device 100 having aspects of the invention, for detecting an analyte 101 (e.g., inorganic species such as NH₃, CO₂, H₂S, NO and the like; organic compounds such as glucose, ethanol and the like; biomolecules such as DNA, globular proteins and the like). A number of alternative sensor device architectures and operating modes are possible, and may be employed alone or in combinations without departing from the spirit of the invention. In the example of FIG. 1, sensing device 100 includes a nanostructure sensor 102 configured for convenient transconductance measurements, as well as other properties. Sensor 102 comprises a substrate 104.

[0092] Sensor 102 comprises a conductive (e.g., semiconductive) nanostructured element configured to include a channel, coating or layer 106 and comprising a nanostructured material (e.g., one or more conducting or semiconducting nanotubes, nanorods, nanowires and/or nanoparticles; a film, mat or network of nanotubes; combinations of these; or the like). The nanostructured element (layer or channel 106) may be disposed adjacent the substrate 104. Channel or layer 106 may contact the substrate as shown, or in the alternative, may be spaced a distance away from the substrate, with or without a layer of intervening material. In a preferred embodiment, layer 106 comprises an interconnecting network including a plurality of semiconducting single-walled carbon nanotubes (SWNTs).

[0093] One or more conductor elements, contacts or electrodes 110, 112 may be disposed over the substrate and electrically connected to channel or layer 106. In the example shown in FIG. 1, the device 100 is configured to facilitate measurements of transconductance properties of channel 106 as influenced or modulated by a constant or variable gate voltage V_g, in this case by employment of substrate 104 as a gate electrode. However, alternative configurations are useful (see discussion of FIG. 3).

[0094] Elements 110, 112 may comprise metal electrodes in contact with conducting channel 106. In the alternative, a conductive or semi-conducting material (not shown) may be interposed between contacts 110, 112 and conducting channel 106. Contacts 110, 112 may comprise source and drain electrodes, respectively, upon application of a source-drain

voltage V_{sd}. The voltage or polarity, of source 110 relative to drain 112 may be variable, e.g., the applied voltage may be DC, AC, pulsed, or variable. In an embodiment of the invention, the applied voltage is a DC voltage.

[0095] In an embodiment of the invention, conducting channel 106 may comprise a plurality of carbon nanotubes forming a mesh, film or network. Such a network may be formed by various suitable methods. One suitable approach may comprise forming an interconnecting network of single-wall carbon nanotubes directly upon the substrate, such as by reacting vapors in the presence of a catalyst or growth promoter disposed upon the substrate. For example, single-walled nanotube networks can be grown on silicon or other substrates by chemical vapor deposition from iron-containing catalyst nanoparticles with methane/hydrogen gas mixture at about 900 deg. C. Advantageously, the use of highly dispersed catalyst or growth-promoter for nanostructures permits a network of nanotubes of controlled diameter and wall structure to be formed in a substantially random and unclumped orientation with respect to one another, distributed substantially evenly at a selected mean density over a selected portion of the substrate.

[0096] Alternatively, a nanotube network may be deposited on a device substrate by spray deposition and the like. For example, single wall carbon nanotubes (SWNTs) and/or other nanoparticles may be suspended in a suitable fluid solvent, and sprayed, printed or otherwise deposited in a substrate. The SWNTs or other nanoparticles may optionally have additional functionalization groups, purification and/or other pre-deposition processing. For example SWNTs functionalized with poly m-aminobenzene sulfonic acid (PABS) show hydrophilic properties and may be dispersed in aqueous solutions.

[0097] One or more conductive traces or electrodes may be deposited after deposition, or alternatively, the substrate may include pre-patterned electrodes or traces exposed on the substrate surface. Similarly, alternative embodiments may have a gate electrode and a source electrode supported on a single substrate. The substrate may include a flat, sheet-like portion, although one skilled in the art will appreciate that geometric variations of substrate configurations (rods, tubes or the like) may be employed without departing from the spirit of the inventions.

[0098] The density of a network of nanotubes (or other nanostructure elements) may be adjusted to achieve a selected conductivity in an electrically continuous network via interconnections between adjacent nanotubes (e.g., a CNT film of density close to but greater than the percolation limit). For example, this may be achieved through controlled CVD conditions (e.g., catalyst particle density, deposition environment, duration, or the like); by controlled flow through a filter membrane (see L. Hu et al., "Percolation in Transparent and Conducting Carbon Nanotube Networks", Nano Letters (2004), 4, 12, 2513-17, which is incorporated by reference), by controlled deposition from a fluid carrier (e.g., spray deposition); or the like.

[0099] In a spray-deposition example, multiple light, uniform spray steps may be performed (e.g., with drying and resistance testing between spray steps) until the network sheet resistance reaches a target value (implying a target network density and conductivity). In one example, P2-SWNTs produced by Carbon Solutions, Inc of Riverside,

Calif. were spray-deposited on a portion of a PET sheet substrate with pre-patterned traces until a sheet resistance about 1 k Ω was reached.

[0100] See also the methods for making nanotube networks as well as additional device and substrate alternatives as described the following patent applications, each of which is incorporated by reference: U.S. patent application Ser. No. 10/177,929 filed Jun. 21, 2002 entitled “Dispersed Growth Of Nanotubes On A Substrate”, (PCT equivalent published as WO04-040,671); U.S. application Ser. No. 10/846,072 filed May 14, 2004, entitled “Flexible nanotube transistors” (Publication 2005-0184,641); U.S. patent application Ser. No. 11/274,747 filed Nov. 14, 2006 entitled “Nanoelectronic Glucose Sensors”; and U.S. Patent Application No. 60/748,834, filed Dec. 9, 2005, entitled “Nanoelectronic Sensors Having Substrates With Pre-Patterned Electrodes, And Environmental Ammonia Control System”.

[0101] Similar methods of making and depositing alternative nanostructures may be employed, so as to configure a nanostructured elements comprising a networks or film of, for example, nanospheres, nanocages, nanococoons, nanofibers, nanowires, nanoropes and nanorods, or mixtures thereof, having compositions including carbon, boron, boron nitride, and carbon boron nitride, silicon, germanium, gallium nitride, zinc oxide, indium phosphide, molybdenum disulfide, and silver.

[0102] In the example of FIG. 1, the device 100 may be operated as a gate-controlled field effect transistor, with sensor 102 further comprising a gate electrode 114. Such a device is referred to herein as a nanotube field effect transistor or NTFET. Gate 114 may comprise a base portion of substrate 104, such as a doped-silicon wafer material isolated from contacts 110, 112 and channel 106 by a dielectric layer 116, so as to permit a capacitance to be created by an applied gate voltage V_g . For example, the substrate 104 may comprise a silicon back gate 114, isolated by a dielectric layer 116 comprising SiO₂. Alternatively gate 114 may include a separate counter electrode, liquid gate or the like.

[0103] Sensor 102 may further comprise a layer of inhibiting or passivation material 118 covering regions adjacent to the connections between the conductive elements 110, 112 and conducting channel 106. The inhibiting material may be impermeable to at least one chemical species, such as to the analyte 101 or to environmental materials such as water or other solvents, oxygen, nitrogen, and the like. The inhibiting material 118 may comprise a passivation material as known in the art, such as silicon dioxide, aluminum oxide, silicon nitride, or other suitable material. Further details concerning the use of inhibiting materials in a NTFET are described in prior co-invented U.S. Pat. No. 6,894,359 entitled “Sensitivity Control For Nanotube Sensors” which is incorporated by reference herein.

[0104] Device 100 may further comprise suitable circuitry in communication with sensor elements to perform electrical measurements. For example, a conventional power source may supply a source drain voltage V_{sd} (113) between contacts 110, 112. Measurements via the sensor device 100 may be carried out by suitable measurement circuitry represented schematically by meter 122 connected between contacts 110, 112. In embodiments including a gate electrode 114, a conventional power source 124 may be connected to provide a selected or controllable gate voltage V_g . Device 100 may include one or more electrical supplies and/or a signal control

and processing unit (not shown) as known in the art, in communication with the sensor 102.

[0105] Optionally, device 100 may comprise a plurality of sensors like sensor 102 disposed in a pattern or array, such as described in prior application Ser. No. 10/388,701 filed Mar. 14, 2003 entitled “Modification Of Selectivity For Sensing For Nanostructure Device Arrays” (now published as US 2003-0175161), which is incorporated by reference herein. Each device in the array may be functionalized with identical or different functionalization. Identical device in an array can be useful in order to multiplex the measurement to improve the signal/noise ratio or increase the robustness of the device by making redundancy. Different functionalization may be useful for providing differential sensitivity so as to permit measurement of a profile of different responses to analytes.

[0106] The substrate 104 may be insulating, or on the alternative, may comprise a layered structure, having a base 114 and a separate dielectric layer 116 disposed to isolate the contacts 110, 112 and channel 106 from the substrate base 114. The substrate 104 may comprise a rigid or flexible material, which may be conducting, semiconducting or dielectric. Substrate 104 may comprise a monolithic structure, or a multilayer or other composite structure having constituents of different properties and compositions. For example, in an embodiment of the invention, the substrate 104 may comprise a silicon wafer doped so as to function as a back gate electrode 114. The wafer being coated with intermediate diffusion barrier of Si₃N₄ and an upper dielectric layer of SiO₂. Optionally, additional electronic elements may be integrated into the substrate for various purposes, such as thermistors, heating elements, integrated circuit elements or other elements.

[0107] In certain alternative embodiments, the substrate may comprise a flexible insulating polymer, optionally having an underlying gate conductor (such as a flexible conductive polymer composition), as described in application Ser. No. 10/846,072 filed May 14, 2004, which application is incorporated by reference. In further alternative embodiments, the substrate may comprise a polymeric substance coated with nanotube or other nanostructure particles in the in the manner described in U.S. application Ser. No. 11/274,747 filed Nov. 14, 2005, which application is incorporated by reference.

[0108] The conducting channel 106 (e.g., a carbon nanotube layer) may be functionalized to produce a sensitivity to one or more target analytes 101. Although nanostructures such as carbon nanotubes may respond to a target analyte through charge transfer or other interaction between the device and the analyte, more generally a sensitivity can be achieved by employing a recognition material 120, also called a functionalization material, that induces a measurable change in the device, characteristics upon interaction with a target analyte. In addition or in substitution to the metallic nanoparticle functionalization, of the exemplary embodiments described in detail herein, the functionalization may alternatively include metal oxides, metal salts, polymers, and the like. Likewise, functionalization may include composite nanoparticles, mixtures of materials or the like.

[0109] In the exemplary embodiments described in detail herein, the recognition material disposed upon the channel 106 comprises on or more metallic materials. In particular, alternative embodiments of arrays of sensors such as shown in FIG. 1 may be functionalized with a range of materials different catalytic metals to produce cross-sensitive NTFET sensor elements.

[0110] FIG. 2 are photographic views (a-d) of a sensor system **100** such as shown in FIG. 1, wherein views (a-c) include SEM images showing (a) showing the layout of interdigitated source and drain contacts **S 110** and **D 112**, (b) showing an enlarged detail of a nanotube network **N 106** and the contacts **S 110** and **D 112**, and (c) showing an enlarged detail of the margin of network **N 106**. View (d) shows an example of a sensor device **100** mounted in a conventional electronic device package **130**. Note that the extent of a carbon nanotube network may be conveniently controlled by selective or masked oxidation of nanotubes from peripheral regions of the substrate **104** (“ashing”).

[0111] The conducting channel **106** (e.g., a carbon nanotube layer) may be functionalized to produce a sensitivity to one or more target analytes **101**. Although nanostructures such as carbon nanotubes may respond to a target analyte through charge transfer or other interaction between the device and the analyte, a specific sensitivity may be achieved by employing a recognition material **120**, also called a functionalization material, that induces a measurable change in the device characteristics upon interaction with a target analyte.

[0112] Device **100** may be packaged in a conventional manner to conveniently permit connection to operating circuitry. FIG. 2, view (d) is a photograph of a sensor device **100** generally similar to that of views (a-c), fabricated on a die of a wafer, and mounted as a chip in a conventional 40 pin CERDIP package using wirebonding techniques. Device **100** may further comprise suitable circuitry in communication with sensor elements to perform electrical measurements. For example, a conventional power source may supply a source-drain voltage (V_{sd}) between contacts **110**, **112**. Measurements via the sensor device **100** may be carried out by circuitry represented schematically by meter **122** connected between contacts **110**, **112**. In embodiments including a gate electrode **114**, a conventional power source **124** may be connected to provide a selected or controllable gate voltage (V_g). Device **100** may include one or more electrical supplies and/or a signal control.

[0113] Ammonia detection. A nanotube network device such as is shown in FIG. 2 may be functionalized as an ammonia detector having aspects of the invention, as described in U.S. patent application Ser. No. 10/656,898 filed Sep. 5, 2003 (published 2005-0279,987) entitled “Polymer Recognition Layers For Nanostructure Sensor Devices”; and U.S. patent application Ser. No. 11/541,794, filed Oct. 2, 2006 entitled “Nanosensor Array For Electronic Olfaction”, incorporated by reference herein.

[0114] A recognition layer (corresponding to **120** in FIG. 1) may be applied to the nanotube network **106** using any suitable method. For example, in an embodiment of the invention, the substrate **104**, electrodes **110**, **112** and nanotube network **106** were submerged in a solution of poly(ethylene imine) (PEI, average molecular weight ~25,000, Aldrich) at about 20% by weight in methanol. After soaking overnight, they were removed and rinsed with methanol. A thin layer, such as less than 10 nm of PEI coated the exposed portion of nanotube **106** after rinsing. Other suitable polymers, or combinations of polymers, may be substituted for PEI. Other solvents and rinse agents may also be suitable.

[0115] FIG. 3A shows the device characteristics for a transistor device (NTFET) embodiment without additional functionalization (bare nanotubes). The left hand plot of FIG. 3A shows the ammonia concentration in ppm and the conduc-

tance at initial zero NH_3 concentration (i-ii), a sustained pulse of 200 ppm (ii-iii) having a loss of conductance, followed by a recover period of zero ppm (iii-iv). The right hand plot of FIG. 3A shows the variation of conductance as a function of gate voltage (note hysteresis during sweep), the upper curve set representing point (i) prior to ammonia pulse, and the lower curve set representing point (iii) after full response to ammonia pulse, but before recovery. Note that the shape of the device characteristic curve set is generally similar, the response to ammonia being an overall reduction in conductance at both positive and negative gate voltages.

[0116] FIGS. 3B and 3C show the response of the non-functionalized device and the PEI functionalized device, respectively, to exposure to pure ammonia gas. It may be seen that functionalization with PEI improved the response of the semiconducting nanostructure device for NH_3 . As seen in FIG. 3B, the non-functionalized device responds with a modest reduction in current, followed by comparatively slow recovery. In contrast, the response and recovery of the PEI-functionalized ammonia sensor (FIG. 3C) is remarkably fast, and the device responds with a substantial increase in current. Upon exposure to pure ammonia gas the current increases from 400 nA to 800 nA. The measured change in current is dependent on ammonia concentration. When the device was exposed to different concentrations of ammonia in argon, a change in the device conductivity was found to be proportional to ammonia concentration. The response to ammonia is also dependent on a gate voltage. At positive gate, measured current through the PEI-functionalized device is increasing significantly. This is true with or without the functionalization material.

[0117] Alternative Nanosensor Architectures.

[0118] FIG. 4 shows one example of an exemplary electronic sensing device **130** having aspects of the invention, similar in a number of respects to the device of FIG. 1, configured in this example as a capacitance sensor for detecting an analyte, as further described in commonly invented and assigned U.S. Provisional Applications No. 60/773,138 filed Feb. 13, 2006; No. 60/660,441, filed Mar. 10 2005; and No. 60/669,126, filed Apr. 6, 2005, each of which is incorporated by reference. Where appropriate, the same reference numerals are used to denote elements which may have commonality of function with respect to FIG. 1. Nanostructured capacitance sensors may be used in conjunction with transconductance sensor modalities, so as to increase specificity, reduce cross sensitivity, and to provide an additional means of sensor calibration.

[0119] As shown in FIG. 4, Sensor device **130** includes a nanostructure sensor **131** which includes a conductive nanostructured element configured to include a channel, coating or layer **106** comprising a nanostructured material (see description of example of FIG. 1). In an exemplary embodiment, the nanostructured material includes a carbon nanotube network **106**, disposed upon a substrate comprising a dielectric isolation layer **116** disposed upon a base **114**, in this example a doped silicon wafer back gate.

[0120] The nanotube network **106** is contacted by at least one conductive electrode **110** (in this case having optional passivation on the electrode-nanotube contact region). A conditioning/recognition structure **138** may be included, disposed adjacent network **106** and may included functionalization or recognition material, analyte conditioners (e.g., a filter, selectively permeable polymer, etc.) and the like.

[0121] The sensor device 130 further includes at least a capacitance measurement circuit 136 in electrical communication with contact 110 and back gate 114, so as to permit the capacitance and/or impedance of the spaced apart nanotube network/back gate assembly to be readily measured (i.e., the total charge required to be placed on either conductor to create a given voltage potential between conductors, $C=Q/V$).

[0122] It should be understood that other capacitor conductors may be substituted for back gate 114 or added to the device 1300 without departing from the spirit of the invention, such as a top gate, liquid gate, a second spaced-apart nanotube network conductor, and the like. Additionally, many alternative functional arrangements of the respective conductors are possible. The capacitance C of the sensor 131 may be calibrated, and compared analytically with the capacitance during exposure to analyte of interest 110. In particular, species having significant dipole moments may act to change the capacitance upon interaction with the nanotube network 106. As shown in FIG. 4, additional functionalization 138 may be included in sensor 131 (e.g., an absorbent filter, a selectively permeable polymer layer, a selectively reactive or binding species, etc., to enhance selectivity, sensitivity and/or signal strength).

[0123] Combined conductance and capacitance measurements. Simultaneous conductance and capacitance measurements on a nanostructure sensor element (e.g., a single-walled carbon nanotube (SWNT) network) may be used to extract an intrinsic property of molecular adsorbates. From a comparison of FIG. 1 and FIG. 4, it may be seen that a single sensor configuration may be combined with circuitry permitting measurements in several modalities from a single sensor. Alternatively, a plurality of differently configured sensors may be employed. Measurements may be made of related properties as well, such as impedance of a sensor having a capacitive circuit architecture below).

[0124] For example, adsorbed analytes produce a rapid response in both the capacitance and the conductance of a SWNT network. These responses are caused by a combination of two distinct physiochemical properties of the adsorbates: charge transfer and polarizability. It has been shown that the ratio of the conductance (or resistance) response to the capacitance response is a concentration-independent intrinsic property of a chemical vapor that can assist in its identification. See Eric S. Snow and F. Keith Perkins, "Capacitance and Conductance of Single-Walled Carbon Nanotubes in the Presence of Chemical Vapors", *Nano Lett* (2005) 5 (12), 2414-2417, which publication is incorporated by reference.

[0125] Thus, a sensor system may produce a response which characterizes analyte identity in one output or signal analysis mode, and produce a response which characterizes analyte concentration in another output or signal analysis mode. In one exemplary embodiment having aspects of the invention, a sensor system may include capacitance and resistance measurement/processing circuitry communicating with a nanosensor (e.g., such as in FIG. 1) to determine the identity of an analyte employing a ratio of the resistance and capacitance change upon exposure to an analyte sample, and then determine a concentration of the thus-identified analyte from the capacitance change based on analyte-specific calibration data.

[0126] FIGS. 5A and 5B are plots illustrating one example of the use of multiple measurement modalities for analyte detection and discrimination. The measurements represent

the response of a sensor having aspects of both FIGS. 1 and 4. In each case, the sensor was exposed to a sequential set of samples of an analyte gas in air, through a graded series of concentrations. The samples are administered in timed pulses of approximately 60 second duration each. The overlay dashed line at each concentration is not a measured value, but an approximated mean level, shown for clarity and convenience. The sensors employed in the examples of FIGS. 5A-5B included a directly-exposed nanotube network, although various functionalization and conditioning layers or materials may optionally be included (see FIG. 4). In each plot, a capacitance response to an exemplary analyte species is shown superimposed upon a signal measuring the simultaneous source-drain resistance, the capacitance units being shown on the left-hand axis, and the resistance units on the right-hand axis.

[0127] FIG. 5A shows the response of both capacitance signal resistance signals to samples of an exemplary analyte in air, in this example the anesthetic agent, isoflurane. The response of the device to the analyte in both the capacitance and resistance signals can be seen to be very rapid, with a rapid recovery. The relation of capacitance to isoflurane concentration can be seen to be in the opposite direction, each generally proportional in magnitude to the other. The arrows to the right of the plot illustrate the magnitude and ratios of the respective measurements at a 5% analyte concentration.

[0128] FIG. 5B shows the comparable responses of both capacitance signal resistance signals to samples of halothane in air; respectively, plotted in the same manner as FIG. 5A. The arrows to the right of the plot illustrate the magnitude and ratios of the respective measurements at a 5% analyte concentration.

[0129] Halothane and isoflurane are chemically similar, have similar properties, but may be distinguished based on the relative magnitude of the responses (e.g., a ratio of ~ 185 for isoflurane vs. ~ 169 for halothane). This ratio may be used to confirm or distinguish the identity of an analyte, and advantageously this may be done in conjunction with the simultaneous measurement of the agent's concentration. Where V_g is the voltage of a substrate gate such as is shown in FIG. 1, the signals of capacitance and conductance (or resistance) may be converted for comparison (e.g., ratio calculation) to normalized values in units of ΔV_g that represent the change in the substrate gate electrode (counter electrode) voltage required to produce an equivalent change in capacitance ΔC (or change in resistance ΔR), i.e. $\Delta C^* = \Delta C / (dC/dV_g)$ and $\Delta R^* = \Delta R / (dR/dV_g)$ where the derivatives are evaluated at $V_g=0$.

[0130] Optional Device Elements. Optionally, a nanosensor device having aspects of the invention may include integrated temperature control elements. Temperature control may be used to control sensor sensitivity, selectivity, and/or recovery time. Thermal control may also be used to carry out analyte-related processes, such as polynucleotide hybridization and denaturation, stringency conditions, PCR, biomolecule conformation changes and the like.

[0131] For example, a nanosensor may include ohmic thermal regulation of the nanotubes of the channel, as described in U.S. patent application Ser. No. 10/655,529 filed Sep. 4, 2003 entitled "Improved Sensor Device With Heated Nanostructure", which is incorporated by reference.

[0132] In another alternative embodiment, the sensor device may include a microfabricated heater element and a thermal isolation structure, such as a substrate bridge or a suspended membrane. Such components may include tem-

perature feedback sensors, such as thermistors, to assist in automated thermal control, e.g., using a microprocessor, as further described in commonly invented and assigned U.S. application Ser. No. 11/488,465 60/700,953, filed Jul. 18, 2006, entitled “Nanoelectronic Sensor With Integral Suspended Micro-Heater”, which is incorporated by reference. See also C. Tsamis et al, “Fabrication of suspended porous silicon micro-hotplates for thermal sensor applications”, Physica Status Solidi (a), Vol 197 (2), pp 539-543 (2003); A Tserepi et al, “Fabrication of suspended thermally insulating membranes using front-side micromachining of the Si substrate: characterization of the etching process”, J of Micro-mech. and Microeng, Vol 13, pp 323-329 (2003); A Tserepi et al, “Dry etching of Porous Silicon in High Density Plasmas”, Physica Status Solidi (a), Vol 197 (1), pp 163-167 (2003), each of which is incorporated by reference.

B. Exemplary Flexible Substrate Nanosensors

[0133] A number of alternative methods of forming a nanostructure network channel (e.g., N in FIG. 1C) may be employed without altering the underlying principal of operation of nanosensors having aspects of the invention. In certain embodiments (e.g., for fabrication condition compatibility), it is advantageous to form a nanotube (or other nanostructure) network on an initial substrate, and subsequently transfer the network to a final device substrate. See for example, the methods described in U.S. patent application Ser. No. 10/846,072, filed May 14, 2004 (published 2005-0184,641), entitled “Flexible Nanotube Transistors”, which is incorporated by reference.

[0134] As shown in FIG. 6 (corresponding to FIG. 2 of the above referenced application Ser. No. 10/846,072) in one alternative method, flexible nanostructure electronic device **200** is formed as follows: Step **201** includes depositing or growing (for example, by chemical vapor deposition) a nanotube film **208** on a rigid substrate **220**. Substrate **220** may comprise, for example a silicon material **222** covered by a layer of silicon oxide **221**. Optionally, contacts **224**, **226** may be formed on the substrate, either before or after the nanotube film is formed. At step **202**, nanotube film **208** and substrate **220** may be coated with a flexible substrate layer **210**. Flexible substrate layer **210** may comprise any suitable material capable of forming a coating film, for example, a liquid polymer. Other polymers that may be used to effect a conductivity change in nanotubes in response to absorption of target species. Alternative materials for layer **210** may include, for example, those identified in TABLE 3. Such materials may be included in sensors such as are describe herein, alone or in combination, without departing from the spirit of the invention.

TABLE 3

Examples of alternative recognition materials	
Polyacrylic acid	Polyurethane resin
Poly(acrylic acid-co-isooctylacrylate)	Polycarbazole
poly(ethylene imine), “PEI”	poly(sulfone)
poly(4-vinylphenol)	poly(vinyl acetate)
poly(alkyl methacrylate)	poly(vinyl alcohol)
poly(a-methylstyrene)	poly(vinyl butyral)
poly(caprolactone)	polyacrylamide
poly(carbonate bisphenol A)	polyacrylonitrile
poly(dimethylsiloxane)	polyaniline
poly(ethylene glycol)	polybutadiene
poly(ethylene oxide)	polycarbonate

TABLE 3-continued

Examples of alternative recognition materials	
poly(ethylenimine)	polyethylene
poly(methyl vinyl ether-co-maleic anhydride)	polyoxyethylene
poly(N-vinylpyrrolidone)	polypyrrole
poly(propylene)	polytetrafluoroethylene
poly(styrene)	polythiophene
polyvinyl-methyl-amine	Polyvinyl pyridine
polyaminostyrene	
chitosan	chitosan HCL
polyallylamine	polyallylamine HCL
poly(diallylamine)	poly(diallylamine) HCL
poly(ethylene-co-vinyl acetate), ~82% ethylene	poly-(m-aminobenzene sulfonic acid), “PABS”
poly(styrene-co-allyl alcohol), ~5.7% hydroxyl	poly(vinyl chloride-co-vinyl acetate), ~10% vinyl acetate
poly(styrene-co-maleic anhydride), ~50% styrene	poly(vinylidene chloride-co-acrylonitrile), ~80% vinylidene chloride
metalloporphyrin (M-porph)	Poly-L-lysine
Alpha-fetoprotein Profile Four (AFP4)	glycerol
Poly methyl methacrylate (PMMA)	polyglycerol
Nafion NR 50	Triton 100 and similar surfactants or amphiphilic species
metal coatings and nanoparticles, and alloys or mixtures of these:	Fe, V, Au, Pt, Pd, Ag, Ni, Ti, Cr, Cu, Mg, Al, Co., Zn, Mo, Rh, Sn, W, Pb, Ir, Ru, Os
inorganic coatings and/or nanoparticles:	
V ₂ O ₅	WO ₃
Cu(SO ₄)	Boric/Boronic acid
ZnO	Boron Trichloride
Al ₂ O ₃	ZrO ₂
Fe ₂ O ₃	CaCl ₂

[0135] Materials in the functionalization layer may be deposited on the NTFET using various different methods, depending on the material to be deposited. It should be understood that mixtures, alloys and composites of the materials may also be included. For many materials, ALD methodology is known which is suitable for depositing thin, uniform layers or coatings, which may be controlled to deposit on selected portions of a device, and which may be employed to produce mixtures or multi-layer coatings also. Other methods may be employed. For example, inorganic materials, such as sodium carbonate, may be deposited by drop casting from 1 mM solution in light alcohols. The functionalized sensor may then be dried by blowing with nitrogen or other suitable drying agent. Polymeric materials may be deposited by dip coating. A typical procedure may involve soaking of the chip with the carbon nanotube device in 10% polymeric solution in water for 24 hours, rinsing with water several times, and blowing the chip dry with nitrogen. Polymers which are not soluble in aqueous solutions may be spin coated on the chip from their solutions in organic solvents. Values of polymer concentrations and the spin coater’s rotation speeds may be optimized for each polymer.

[0136] Polymers such as the foregoing may be dissolved and coated on nanostructures in a manner similar to that described for PEI above. Polymer and non-polymer materials other than those listed above may also be useful. It is possible that the exemplary polymer layer acts to cause a selective response by the nanostructure to target species that are selectively absorbed or otherwise interacted with by the polymer layer on the nanostructure. This suggests that a nanostructure

sensor may be made to respond selectively to a particular material, by coating it with a polymer or material having a known selective affinity for the desired target. Also, more than one material may be included in a target group by combining polymers with different affinities. The polymer layer may be modified to produce different effects. For example, part of the nanotube or other nanostructure may be masked during a coating process for the polymer layer. After the polymer layer is applied, the masking layer may be stripped away, leaving a discontinuous polymer layer on the nanotube. Using a similar process, different polymers may be deposited at different places along a nanostructure.

[0137] The polymer or other recognition material should be selected to provide the electrical and mechanical properties that are desired for the substrate of the device to be formed. The polymer **210** may be deposited as a liquid layer, and then cured, hardened, or otherwise solidified to provide the desired substrate material.

[0138] At step **203**, rigid substrate **220** is removed from substrate **210**, for example, by dissolving the substrate in a suitable etching agent. Optionally, one or more electrodes (not shown) may be formed on the exposed surface of substrate layer **210**, either before or after it is removed from the rigid substrate. For example, a gate electrode (not shown at **203**) may be placed opposite to the nanotube film **208**. Turning substrate **210** over should yield a device **230** as shown at the lower left of FIG. **6** (shown rotated 180 degrees relative to its position at **201**). The device **230** may comprise source and drain electrodes **224**, **226**, nanotube network **208** connecting the source and drain, and a gate electrode **228** on the opposite side of dielectric flexible substrate layer **210**.

[0139] A nanotube network was grown by chemical vapor deposition on a silicon substrate with a 200 nm silicon oxide coating, as described in U.S. patent application Ser. No. 10/177,929, filed Jun. 21, 2002 by Gabriel et al., which is hereby incorporated by reference, in its entirety. Then the silicon substrate with the network was patterned with optical lithography, and a liftoff process, to form 100 .mu.m square metal contacts. The metal contacts comprised a 3.5 nm thick titanium film covered by a 50 nm thick gold film. After liftoff, the silicon substrate with network and metal contacts was spin-coated with polyimide (HD 2610, 500 rpm). The silicon substrate was heated at 90 deg C for 10 minutes, 120 deg C for 5 minutes, and 200 deg C for 30 minutes to cure the polyimide. Finally, the silicon substrate was immersed in 10% hydrofluoric acid (HF) for 8 hours. The polyimide films, floating freely in the HF solution, were removed and rinsed with deionized water.

[0140] FIG. **7** shows the NH₃ sensing capabilities of a nanosensor embodiment having aspects of the invention, in this case a sensor constructed by the method of FIG. **6**. Introduction of NH₃ to a test chamber caused a rapid and easily measured change in conductivity of the device.

C. Exemplary Solution Deposition Nanosensors

[0141] Solution Deposition Nanoparticle Network. In an alternative, the nanostructure conducting layer comprising an interconnecting network of nanostructures may be formed by deposition from a solution or suspension of nanostructures, such as a solution of dispersed carbon nanotubes. See for example, the methods described in U.S. patent application Ser. No. 10/846,072, filed May 14, 2004 (published 2005-0184,641), entitled "Flexible Nanotube Transistors", which is incorporated by reference. Such methods as spin coating,

spray deposition, dip coating and ink-jet printing may be employed to deposit the solution or suspension of nanostructures.

[0142] In certain embodiments, a micro-porous filter, membrane or substrate may be employed in deposition of a nanotube (or other nanoparticle) network channel from suspension or solution. A porous substrate can accelerate deposition by removing solvent so as to minimize "clumping", and can assist in controlling deposition density. The deposition may be carried out by capillary absorption, or using suction or vacuum deposition across the porous substrate or membrane, as described in the above referenced application Ser. No. 10/846,072 (e.g., see description of FIG. **3** and Example B of that application); in U.S. Provisional Application No. 60/639,954 filed Dec. 28, 2004 entitled "Nanotube Network-On-Top Architecture For Biosensor"; and in L. Hu et al., Percolation in Transparent and Conducting Carbon Nanotube Networks, Nano Letters (2004), 4, 12, 2513-17, each of which application and publication is incorporated herein by reference. The network thus formed may be separated from the deposition membrane using a method such as membrane dissolution or transfer bonding, and included in a sensor device structure as a conducting channel (e.g., disposed on a device substrate, contact grid, or the like).

[0143] Alternatively, a nanotube (or other nanoparticle) network deposited on a micro-porous substrate may be included in a sensor device as disposed upon the deposition substrate or membrane. This arrangement may simplify fabrication, and has the advantage of permitting analyte media flow perpendicularly through the pores of the device substrate, as further described in commonly invented and assigned U.S. Provisional Application No. 60/669,126, filed Apr. 6, 2005, entitled "Systems Having Integrated Cell Membranes And Nanoelectronics Devices, And Nano-Capacitive Biomolecule Sensors, which is incorporated by reference.

[0144] FIG. **8A** is a diagram of an alternative exemplary embodiment of a nanosensor **20** having aspects to the invention, including a network of carbon nanotubes. Sensor **20** comprises a substrate **9**, which may comprise a flexible sheet-like material such a polyester polymer (e.g., PET sheet). One or more electrodes (**3a** and **3b** are shown) are arranged on the substrate. The electrode **3** may comprise a metal, or may be formed from a paste or ink-like composition, such as carbon, graphite, conductive polymer, metallic ink compositions, and the like.

[0145] A nanostructure layer **2** (in this example a film including SWNTs) is deposited contacting the electrodes **3a** (and **3b** in this example). Preferably the nanostructure layer **2** is formed by spraying or otherwise coating the patterned substrate with an liquid suspension of nanotubes, as is described in detail herein and in the incorporated references. For example, SWNTs or MWNTs may be conveniently dispersed in aqueous suspension at a desired concentration, particularly where functionalization treatment of the SWNTs assist in making the nanotubes hydrophilic. Alternative organic solvents may likewise be used to disperse and apply the nanotube film **2**. See for example, U.S. patent application Ser. No. 10/846,072 entitled "Flexible Nanotube Transistors"; and L. Hu et al., Percolation in Transparent and Conducting Carbon Nanotube Networks, Nano Letters (2004), 4, 12, 2513-17, each of which application and publication is incorporated herein by reference.

[0146] In the example of FIG. **8A**, the electrodes **3a**, **3b** are shown deposited upon substrate **9** beneath the SWNT film **2**,

as this advantageously permits the use of substrates having pre-printed or pre-patterned electrode material, which permits substantial costs savings in volume production. However, other electrode configurations are possible without departing from the spirit of the invention.

[0147] In the example shown in FIG. 8A, an optional functionalization or recognition layer 7 is included in association with the layer 2. This applied following deposition of SWNT film 2. In the example shown in FIG. 8B, a layer of recognition material 7' is deposited upon the substrate prior to application of the nanotube film 2, and is disposed underneath film 2. In either of the examples of FIGS. 8A and 8B, a recognition material may penetrate the nanotube network 2 so as to be incorporated as a mixture.

[0148] FIG. 8A shows an optional additional passivation, protective or inhibiting layer 8 may cover electrodes 3 and all or a portion of layers 2 and 7.

[0149] In certain embodiments, recognition or detection material is deposited, reacted or bound to the nanotubes (or alternative nanostructures) prior to deposition of layer 2. Depending on the selected detection chemistry and analyte target, such pre-functionalization may eliminate the need for any distinct recognition layer 7. In the example shown in FIG. 8C, a layer of pre-functionalized nanotubes 12 is deposited upon the substrate, without any separate application of a recognition or functionalization material.

[0150] The nanostructure layer 2 may be deposited stepwise, with intermediate drying, to permit the density and conductivity of the layer 2 to be accurately controlled, such as by probe-testing the layer resistance or conductance between deposition steps, until a selected layer conductivity or resistance is achieved.

[0151] Suitable measurement circuitry is included in communication with electrodes 3a and 3b (and any optional additional electrodes), here represented by meter 6 and source-drain power source Vsd.

D. Exemplary Sensor Having a Pre-Functionalized Nanotube Network

[0152] Sensor fabrication. FIG. 9 shows an exemplary embodiment of a sensor device 50 having aspects of the invention and including a nanotube networks fabricated by deposition of a solution or dispersion of nanotubes upon a substrate 9 to form a nanotube film 12. In an exemplary embodiment shown in FIG. 9, the nanotubes (or other nanostructures) are dispersed in a volatile solvent which evaporates following deposition to leave the nanotubes configured as an open network 12.

[0153] Although electrical contacts may be deposited or applied subsequent to nanotube deposition, it is convenient and advantageous to pattern desired electrode or contact material 3 upon the substrate 9 prior to nanotube deposition (four contacts 3a-3d are shown). For example, substrates (e.g., polymer sheets such as PET, polystyrene, polycarbonate and the like) are commercially made having printable conductor material applied in a selected pattern (e.g., carbon, silver, gold, silver/silver chloride, mixtures and the like). A suitable flexible PET substrates with a pattern of printed conductive carbon traces may purchased from Conductive Technologies, Inc., of York, Pa., for example, a flexible PET substrate with screen-printed carbon paste electrodes, with spacing between the conductive traces of about 1 mm. A plurality of devices may conveniently be fabricated on a sheet of substrate material, and may subsequently be partitioned

and packaged as desired, either as single sensor devices, or as arrays of sensors, and the like.

[0154] In an exemplary embodiment having aspects of the invention, the nanotube network was formed from SWNTs which were functionalized by covalently bonded poly-(m-aminobenzene sulfonic acid ("PABS")). Carbon nanotubes, preferably SWNTs, may be reacted and treated with PABS (composite referred to as "SWNT-PABS") by the methods as described in B Zhao et al, "*Synthesis and Properties of a Water-Soluble Single-Walled Carbon Nanotube-Poly(m-aminobenzene sulfonic acid) Graft Copolymer*", *Adv Funct Mater* (2004) Vol 14, No 1 pp 71-76, which article is incorporated by reference. A suitable nanotube composite material ("SWNT-PABS") may be obtained from Carbon Solutions, Inc. of Riverside, Calif. in the form of a dry powder.

[0155] A variety of alternative functionalization species may be included, such as conductive polymeric materials, polyaniline (PANI), polypyrrole, polyaniline derivatives, and the alternative materials described above in TABLE 3. See, for example, the electrochemical treatments described in T Zhang et al, "*Nanonose: Electrochemically Functionalized Single-Walled Carbon Nanotube Gas Sensor Array*", *Proc. 208th Meeting of Electrochemical Society* (Los Angeles, Calif. Oct. 16-21, 2005), which is incorporated by reference.

[0156] A suitable aqueous deposition solution may be made by suspending SWNT-PABS powder in water (preferably at a concentration of about 1 mg/mL), and ultrasonication may be employed to assist in making a homogeneous dispersion. The carbon nanotube dispersion may be sprayed with an air brush to coat the substrate.

[0157] Preferably the deposition is done in several light coating steps with intermediate drying (for example on a hotplate with the temperature of about 55 to 75 degree C.). The film resistance may be measured between steps until the selected resistance is obtained (the measurement may be between printed traces, or may be by pin probes on the network coating. For example, the deposition may be continued until resistance with a half-inch pin probe spacing is about 15 K Ohm.

[0158] Ammonia Detection. FIGS. 10 and 11 are plots showing the response of the sensor described above with respect to FIG. 8 to ammonia in an automated gas test station. The selected ammonia concentrations were obtained by dilution with nitrogen in a computerized gas dilution system. Prior to measurements, the sensors were purged with nitrogen for 30 min followed by exposure to ammonia for 15 min. The ammonia gas was switched to nitrogen for 5 min between successive test experiments.

[0159] FIG. 10 shows the response of the sensor to repeated exposures and recovery at 50 ppm of ammonia. The response may be seen to be repeatable and consistent.

[0160] FIG. 11 shows the response of the sensor to repeated exposures and intermediate recoveries throughout a 10 fold dynamic range, beginning at 50 ppm, grading upwards to 500 ppm, and grading downward back to 50 ppm. The response may be seen to be generally repeatable and consistent throughout this range. The exemplary sensors rapidly recover their resistance when NH₃ is replaced with argon.

[0161] The forgoing embodiments provide advanced chemical sensors based on chemically functionalized single-walled carbon nanotubes (SWNTs). The inclusion of conductive or semiconductive polymeric functionalization material may improve sensor performance for detection of NH₃ (e.g., covalently attached poly-(m-aminobenzene sulfonic acid

forming a SWNT-PABS composite). The exemplary sensors have ppm sensitive, rapid response, and rapidly recover when NH₃ exposure ceases.

E. Exemplary Environmental Control and Actuator System

[0162] FIG. 12 is a schematic layout diagram of an exemplary environmental control and actuator system including a nanoelectronic ammonia sensor having aspects of the invention. Preferably a plurality of sensing modalities are employed to optimize environmental conditions in an enclosure, such as a poultry house, by controlling ventilation, heating and optionally air cooling. In the example shown, the control system includes at least one ammonia sensor, and optionally a humidity sensor, a temperature sensor, and a sensor specific to an additional environmental gas, contaminant vapor or other species, such as CO₂, NO_x, O₃, CH₄, H₂S, CO, allergens, pathogens, or the like.

[0163] The sensors may be powered by any convenient method, such as line power, batteries, solar cells, and the like. The sensors communicate with a computer processor or microprocessor which includes memory. The processor is preferably in communication with a user input and output/display device, such as a monitor and keyboard. Either wired or wireless communication (or a combination of these) may be employed, for example including conventional network hardware, to connect sensors to the processor. Alternatively the system may be integrated into a single control module.

[0164] For example, it may be advantageous to have a particular sensor (e.g., ammonia) mounted in a wireless remote module, such as is described in U.S. patent application Ser. No. 11/111,121 filed Apr. 20, 2005 (publication 2006-0055, 392) entitled "Remotely communicating, battery-powered nanostructure sensor devices"; which is incorporated by reference. The described nanosensors having aspects of the invention have very low power dissipation, and therefore lend themselves to compact remote installations powered, for example, by a small battery and/or photovoltaic cell. The described remotely communicating sensor devices can be interrogated as needed by a processor located at another convenient location.

[0165] Remote sensor modules permit monitoring an environmental variable at a plurality of locations, and determining ventilation or other control response based on a composition of sensor outputs. Additionally, reliability and accuracy may be improved by including redundant sensors for a particular environmental variable, such as humidity or ammonia, and analyzing sensor outputs to determine a most reliable value for the variable based on statistical or quality control algorithms. See for example the methods described in the above referenced U.S. Pat. No. 5,407,129 issued to Carey et al.

[0166] The processor, memory and user I/O devices permit a user to set control points, review measurement histories, track quality control variables, and/or determine sensor status or maintenance histories, and the like. The processor may also be configured to monitor heater and ventilator fan performance. Conventional feedback control algorithms may be employed to optimize environmental control.

[0167] An environmental actuator system communicates with and responds to commands of the control system, so as to maintain ammonia, humidity and temperature (and optionally an additional analyte) within programmed limits. The actuator system includes such devices as ventilation fans, heaters, and optionally air coolers. The actuator system may

also include scrubbers, filters, particle removers and the like to condition air quality. Generally, ventilation and heater units dissipate power at a higher order of magnitude than the control system sensor and processor functions, and the actuators may conveniently be operated by relays and other conventional power controls, in response to processor commands.

[0168] One of ordinary skill in the art may combine elements of FIG. 12 in alternative ways without departing from the spirit of the invention. For example, it may be advantageous in industrial applications of the control system of FIG. 12 to integrate the control system with a particular actuator modality as a modular control-actuator system. This may be done to simplify installation and maintenance, and to facilitate the economical retrofitting of poultry houses as existing ventilation and heating equipment reaches its service life. Thus, a ventilation unit may be supplied with an integrated environmental control system, and a separate heater unit may be supplied with a separate integrated environmental control system.

F. Alternative Sensor Configurations

[0169] It should be understood that the embodiment shown in FIG. 8 is exemplary, and a number of alternative configurations are possible without departing from the spirit of the invention. Some examples are shown in FIGS. 13A-13E, including alternative embodiments of sensors having aspects of the invention and including nanotube networks fabricated by deposition of a solution upon flexible substrates with pre-patterned conductor traces. It should be understood that the vertical dimension is generally highly exaggerated for clarity, and that thin sheets of substrates, such as a PET, may be printed or coated to very small tolerances with conventional conducting materials. Where the embodiments include generally similar elements, these are numbered the same.

[0170] FIG. 13A shows a NTFET alternative sensor 60 having space-apart source and drain traces 3a and 3b disposed on substrate 9. An additional intermediate trace 14 is coated with a thin layer of dielectric material 15 (organic film or inorganic deposit) prior to deposition of nanotube layer 12, so as to form a gate electrode.

[0171] FIG. 13B shows a sensor 65, generally similar in configuration to that of FIGS. 8-9, and including a plurality of distinct pairs of space-apart patterned source and drain traces on a single substrate are coated with differently functionalized nanotube networks (e.g., traces 3a, 3b coated with nanotube layer 12a, and traces 3c, 3d coated with nanotube layer 12b), so as to have different sensing properties. A gap 17 between nanotube layer portions may be provided (by masking, scoring, and the like) so as to provide electrical isolation between nanotube layers 12a and 12b. Note that this configuration may also be employed to provide reference sensors or calibration sensors in an array format.

[0172] FIG. 13C shows a sensor 70 generally similar to that shown in FIGS. 8-9, and having additional layers of encapsulation or covering material which functions to filter or condition the ambient medium so as to improve selectivity or to protect the sensor. In this example, nanotube layer 12 is covered by either or both of an encapsulation layer 18, and a filter lamination layer (fixed, e.g. by adhesive or taped edges 20). These additional layers 18, 19 can provide a low-cost integrated sensor unit which is protected by the layers (e.g., hydrophobic coatings permeable to the analyte of interest) and with reduced cross-sensitivity (filters selectively absorbing a cross-contaminant, such as NO_x). Such layers 18, 19

may cover all or only a portion of the sensor surface, for example, to isolate a reference sensor from the environment while leaving a measurement sensor exposed. The **18, 19** may also provide abrasion resistance to protect delicate nanotube films, to permit convenient user handling, such as in a disposable sensor.

[0173] FIG. 13D shows a sensor **75** configured as a capacitance sensor in which a nanotube network **12** connects to at least one trace **3**, and is separated from at least one other counter-electrode trace **17** by a defined gap **16** (e.g., gap made by masking, scoring, or the like). Conventional circuitry may be used to measure the change in capacitance of the nanotube layer **12** with respect to the counter electrode **17** in response to an analyte.

[0174] FIG. 13E shows alternative embodiment **80** of a capacitance sensor in which a second substrate **9b** having a counter-electrode trace **17'** is laminated to a first substrate **9a** having a nanotube network **12**, the counter electrode being maintained in a spaced apart arrangement from the nanotube network by spacers to maintain gap **16'**. The spacers may include edge spacers **18** which do not contact the nanotube layer **12** in the region of gap **16'**. Alternatively or additionally, the device may include a thin porous sandwich spacer **20** which provides a dielectric separation between electrode **17'** and layer **12** while permitting the diffusion of analyte. Alternatively, a non-porous dielectric intermediate spacer **21** may be interposed between a portion of counter electrode **17'** and layer **12** to control the dimension of gap **16'**, while leaving other portions of electrode **17'** and layer **12** exposed to analyte.

[0175] It should be noted that spacer-controlled lamination of substrates similar to that shown in FIG. 13E may be included in sensor embodiments such as those of FIG. 13A-13D, so as to create an enclosed lumen or volume for analyte medium, suitable for microfluidic sensors and the like.

[0176] FIGS. 14A-14D illustrate an exemplary embodiment of a sensor system having aspects of the invention, including a disposable sensor generally similar to the embodiment of FIGS. 8-9, and including a sensor mounting socket suitable for integration into an instrumentation module, such as an environmental control system.

[0177] It should be noted that while sensors generally similar to that shown in FIGS. 8-9 may have a long service life, the low cost, low power properties of the sensor embodiments having aspects of the invention lend themselves to a disposable or easily replaceable sensor module. In many applications, it may be advantageous to replace a low-cost sensor at regular intervals, simplifying calibration and quality control procedures. In addition, a "generic" sensor socket may be configured to accept sensors for different analytes or different concentration ranges, making the control module conveniently re-configurable or upgradeable.

[0178] FIG. 14A shows, in cross section and longitudinal section view, an exemplary embodiment of a disposable sensor device **50** having aspects of the invention and including a nanotube network **12** arranged on substrate **9**. Nanotube network **12** connects with one or more conductive traces or contacts **3** disposed on substrate **9**. As may be seen in the left-hand cross section view of FIG. 14A, in this example the contacts **3** include a spaced-apart source-drain pair of traces **3a** and **3b**. The layer **12** is functionalized for sensitivity to an analyte of interest, for example ammonia. As may be seen in the right-hand longitudinal section view of FIG. 14A, in this example the contacts **3a** and **3b** extend beyond the network

layer **12** to be exposed adjacent the end of substrate **9**. A sealant portion **13** (e.g., an elastomer material) is disposed on substrate **9** at the end opposite the exposed contacts.

[0179] FIG. 14B shows in longitudinal section view an exemplary embodiment of a sensor mounting socket **51** having aspects of the invention and suited to mounting the sensor **50** of FIG. 13A. The socket **51** includes a body **52** having a central slot **53b** terminating at one end in opening **53a**. At the opposite end of slot **53a**, the body **52** mounts one or more conductive pins **54b** which have a spring contact portion **54a** protruding into slot **53b**. On one side of body **52** is mounted a sensor orifice/filter **55**.

[0180] FIG. 14C shows, in longitudinal section view, the disposable sensor **50** of FIG. 14A as sealed in a conventional "blister pack" type protective package **56** having a peelable backing. The package **56** may be hermetically sealed, pre-sterilized, and/or protects the sensor **50**, for example from abrasion, humidity and contamination, while providing the sensor ready for immediate use.

[0181] FIG. 14D shows the disposable sensor **50** of FIG. 14A as mounted in the sensor mounting socket **51** of FIG. 14B. Note in this example (although not shown in side section), pins **54** include an electrically isolated parallel pair of pins **54b** and spring contacts **54a** corresponding and communicating with traces **3a** and **3b** respectively of sensor **50**. Note also that nanotube layer **12** of the mounted sensor **50** lies adjacent orifice/filter **55**, which is permeable to at least the analyte of interest. The sealant portion **13** contacts the opening **53a** of slot **53b**, so as to seal the opening when the sensor is mounted. The sensor **50** in this example may be held firmly in place by friction applied by one or both of sealant **13** and spring contacts **54a** (additional or alternative closures and the like may be included).

[0182] FIG. 15 shows an exemplary embodiment of a control system unit **165** employing a sensor having aspects of the invention, such as the disposable sensor **50** and socket **51** of FIGS. 14A-14E. The unit **165** may include many of all of the functional elements shown in the control system of FIG. 12, packaged in a convenient product configuration, such as a battery-powered wall-mounted unit accepting disposable analyte sensors. In this example, unit **165** includes a circuit board **175** for mounting power supply **177**, A/D converter **178**, microprocessor/memory module **176**, wireless or wired I/O connections **168**, thermistor **166**, RH sensor **167**, and the like. The processor board is shown connected to one or more sensor sockets **51** mounting disposable sensors **50** and **50'**. The unit **165** also includes a display **180** and a keypad **181**.

G. Sensor Arrays, and Low Cost Safety Badge Example

[0183] Optionally, The various embodiments of nanoelectronic sensors describe in the above examples may comprise a plurality of sensors disposed in a pattern or array, such as described in prior application Ser. No. 10/388,701, entitled "Modification Of Selectivity For Sensing For Nanostructure Device Arrays" (now U.S. Pat. No. 6,905,655), which is incorporated by reference herein. A sensor array embodiment may provide for a number of advantageous measurement alternatives, methods and benefits according to the invention, for example:

[0184] a. multiple analytes detected by a plurality of specifically functionalized sensors,

[0185] b. improve the signal/noise ratio or increase the robustness of the device.

[0186] c. increased precision and dynamic range by a plurality of sensors each of which is optimized for a different range,

[0187] d. increased analyte specificity and flexibility by detecting a characteristic “profile” of responses of a target analyte to a plurality of differently-functionalized sensors,

[0188] e. self calibration systems and isolated reference sensors,

[0189] f. multiple-use array having a plurality of deployable one-time-use sensor sub-units, or

[0190] g. ultra-low-cost, direct-digital-output sensor arrays, including a plurality of sensors, each producing a binary signal, and collectively having a range of response thresholds covering a selected analyte concentration range.

[0191] Low cost substrate sensors having aspects of the invention generally similar to the embodiments shown in FIGS. 8-9 and FIGS. 13A-13E are well suited to applications such as industrial safety badges and similar equipment.

[0192] FIG. 15 shows an exemplary embodiment of an industrial personnel safety badge 190 having aspects of the invention, comprising a card mount or badge body 191 supported by a swivel clip 192 suitable for attaching the card 190 to a pocket, shirt lapel, jacket or article of clothing (a cord or necklace may also be employed). The badge 190 may include compact, low-cost electronic components generally similar to those found in inexpensive electronic watches, musical gift cards, and the like. Badge 190 is shown including a battery 194, an integrated microprocessor 192 and an user-readable display such as LCD 195. At least one sensor, and preferably a multi-analyte sensor array (see FIG. 12B) having aspects of the invention is mounted to the card 191, arranged so as to sample air next to the card surface, and is connected to processor 192. The display 195 in this example is simple a bar graph showing levels of one or more toxic analytes, such as NH₃, CO, and H₂S, organic vapors and the like.

[0193] Additionally or alternatively to display 195, badge 190 may include sound alerts such as beeper 196 to alert to hazardous analyte levels. Light alerts such as flashing LED 197 may be pre-programmed to alert to hazardous levels also. In additional alternatives, badge 190 may include active or passive RFID-type elements or other wireless communication components (not shown) to provide for remote monitoring of personnel exposure to toxic analytes. The processor may also include memory configured to maintain analyte-specific exposure history, downloadable to permanent record computers.

H. Suspended Network Sensor

[0194] FIG. 17 shows an additional exemplary embodiment of a sensor device 200 having aspects of the invention and including a nanotube network 12 arranged so as to be suspended above and spaced apart from substrate 9. In this example, each of contacts 3a and 3b support a plurality of pillar-like conductors 20a and 20b respectively. Network 12 is supported by, and electrically communicates with, the pillars 20a, 20b. The network 12 may be deposited by a number of methods described herein, such as by CVD growth (e.g., catalyst on pillars), by solution deposition, or by network transfer (e.g., from a vacuum deposited network on a porous substrate, rafted or transferred to adhere to the pillars). This embodiment permits the network 12 and any recognition material associated with it, to interact with analyte species

isolated from substrate influence. Alternative embodiments are possible (such as a capacitive sensor) without departing from the spirit of the invention.

I. Method of Dynamic Sensor Sampling

[0195] In one inventive aspect, a method of dynamic sensor sampling is provided, which permits measurement of analyte concentration over time, while avoiding exposure of the sensor to a sample medium on a continuous basis. For example, a valve or fluidic circulation system may be included to selectively expose a sensor having aspects of the invention to a sample medium. In certain embodiments, a dynamic sampling method permits minimizing exposure of a sensor to corrosive or life-limiting environmental conditions. In other embodiments (e.g., and electrochemical sensor), a dynamic sampling method may conserve reagent supply and extend service life. In yet other embodiments, a dynamic sampling method may avoid irreversible or persistent changes in sensor properties. In still other embodiments a dynamic sampling method may permit more rapid sensor response to changes in analyte conditions and reduce recovery time. A dynamic sampling method may also be employed to reduce cross-sensitivity, where response to a cross-reactant is slower than to a target analyte.

[0196] FIG. 18 is a schematic plot illustrating principles of a dynamic sensor sampling method having aspects of the invention. The vertical axis represents a nominal sensor response magnitude. In the example shown, this is an electrical current I (e.g., across a channel element of a transconductance sensor) but the response may represent any one of a number different sensor properties, such as a conductance, resistance, capacitance, impedance or the like. The response may also represent a complex or derived property, such as a ratio, modulation, time constant, exponent or other relationship associated with measured properties. The response may alternatively represent a statistical property in relation to multiple sensors of a sensor array, such as a mean value or the like.

[0197] As may be seen in FIG. 18, the unexposed sensor is initially at an response level (I_0). Exposure of the sensor to a first analyte concentration (concentration 1) produces a sensor response that increases over time so as to asymptotically approach (dotted curve) a steady-state response magnitude (I_{asym1}). If the sensor is isolated from exposure to a sample (or otherwise prevented from responding to an analyte, such as by a controllable inhibitor) at a point when the response reaches a selected cut-off magnitude (I_{max}), a recovery trend is begun, the response value declining so as to asymptotically approach the initial value I_0 . If the sensor is again exposed to the analyte sample after a recovery interval (Δt), the sensor response again increases (“rise profile”) in a similar manner until the cut-off value I_{max} is reached.

[0198] A second curve in FIG. 18 represents the response of the sensor to an analyte sample of a differing concentration (heavy dashed line—concentration 2), such that the response that increases over time so as to asymptotically approach (dotted curve) a different steady-state response magnitude (I_{asym2}). If the exposure is interrupted at a cut-off value (I_{max}), and the sensor is permitted to recover for a selected interval (Δt), the response curve of concentration 2 is similar to that of concentration 1, but having a differing rise profile (rise profile 1 vs. rise profile 2). Analytical comparison of the rise profiles may be employed to characterized the analyte concentrations, without monitoring the sensor response until a steady-state response magnitude is reached or approached.

[0199] FIG. 19 is a schematic plot an example of dynamic sensor sampling for a step change in analyte concentration. As in FIG. 18, the sampling method in this example applies a fixed maximum response cut-off value I_{max} and a fixed recovery interval Δt . The curve of sensor response shows a change in rise profile following the change in analyte concentration (rise profile 1 vs. rise profile 2). It should be understood that in the example shown, the sensor recovery is consistent, independent of analyte concentration, and approaches (I_0) without a persistent off-set. However, this may not be so, and methods of dynamic sampling may be applied effectively to sensors which do not exhibit these characteristics. For example, accumulated drift in sensor response may be compensated for. A number of alternative analytical algorithms may be applied to correlate rise profile with analyte concentration.

[0200] FIG. 20 is a schematic plot an alternative example of dynamic sensor sampling for a step change in analyte concentration, having both fixed maximum and minimum response cut-off values. As may be seen, the measurement and recovery phases (analyte exposure and isolation) are triggered by a response magnitude reached a maximum and minimum value (I_{max} and I_{min}).

[0201] FIG. 21 is a schematic plot an example of dynamic sensor sampling for a step change in analyte concentration, having a both fixed measurement and recovery intervals. As may be seen, the measurement and recovery phases are triggered by the passage of a determined measurement interval (dt_M) and recovery interval (dt_R).

[0202] It should be understood that a sensor system may employ the sampling modes of FIGS. 18-21 alone, in sequence or in combination. For example, a sensor system may be programmed to apply a certain sampling mode for analyte concentrations in a certain range and another sampling mode for another range of analyte concentrations. for a stand-by or active mode, or the like. Additional alternative modes of sampling may be employed without departing from the spirit of the invention.

[0203] In like fashion to that described in the example above, alternative functionalization materials and alternative device architectures may be included (e.g., alternative electrode elements and nanostructures, such as nanowires, MWNTs, non-carbon or hetero nanotubes other known nanoparticles, and the like). Such alternatives may include measurements of other device properties, such as capacitance, impedance and the like.

[0204] FIG. 22 is a schematic diagram of an exemplary embodiment of a sensor system 250 having aspects of the invention, and configured for employing a dynamic sampling method. System 250 includes a controllable selector valve 252 which interconnects to a sampling fluid path 253, to a purge fluid path 254, and to a measurement fluid path 255.

[0205] System 250 comprises a sensor 251 disposed on measurement fluid path 255, which may include one or more of any of the nanoelectronic sensor embodiments described herein. Sensor 251 may alternatively or additionally comprise any one of a number of alternative sensor types, such as electrochemical sensors, SAW sensors, optical sensors, CMOS sensors and the like.

[0206] In an example system 250 for the monitoring and/or control of an ambient environment, such as ammonia (NH_3) content of the air within a poultry house, sampling path 253 may comprise an inlet 256 from an environmental space which preferably connects to a filter 257 configured to

remove particulates from the sample air. Additional treatment or filter component 258 may be included to remove interferents or contaminants, for example H_2S , from the sample, or may additionally or alternatively include a de-humidifier, such as a cold-trap.

[0207] Purge path 254 may comprise purge gas source 259, such as a source of purified air, dry N_2 , and the like. In one example, purge source 259 comprises sample air having additional filtering or treatment to remove the analyte of interest (e.g., NH_3 absorbent), fed in this example from the sampling path 253 by bypass 260.

[0208] Measurement path 255 receives a multiplexed flow provided by selector valve 252 sequentially comprising sample air and purge air. In this example the selector valve is controlled by processor 261 which is in communication with sensor 251, and may be configured for sampling/purge (measurement/recovery) sequences such as are illustrated in FIGS. 18-21. Alternatively, the multiplexing sequence may be controlled by other mechanisms, such as fixed timers and the like.

[0209] The multiplexing sequence may be selected to apply a duty cycle for sensor measurement, such as on the order of a few percent or less. For certain types of sensor with finite measurement life due to factors such as reagent exhaustion (e.g., many electrochemical sensors), a fractional duty cycle can extend effective sensor life by orders of magnitude.

[0210] Air flow is induced by pump 262 which connects to optional temperature controller 263 (heater and/or cooler), which in turn supplies multiplexed flow (at a selected temperature) to expose sensor 251. Following sensor exposure, the multiplexed flow is emitted at exhaust 264.

[0211] It should be understood that a number of alternative arrangements of system 250 are possible without departing from spirit of the invention, and that the system may be configured for measurement of a broad range of different analytes in different sample mediums (i.e., dissolved analytes in aqueous media). For example, the pump may be provided downstream (262') from sensor 251, and/or may be provided upstream of selector valve 252 (not illustrated). In certain measurement applications the pump may be omitted, as where sample and/or purge flow is provided by other means (e.g., natural convection, fans for space ventilation, gravity flow, pressurized environmental spaces, and the like).

[0212] FIG. 23 illustrates the structure of an exemplary sensing device 251 having aspects of the invention and adapted for measuring an analyte, such as NH_3 , contained in measurement medium 255, for example in a system such as is shown in FIG. 22. The architecture of sensor 251 is generally similar to that shown in FIG. 1. Sensing device 251 includes a nanostructure sensor 302 configured as a field effect transistor, comprising a substrate 304 having a dielectric surface layer 316. Substrate 304 may be comprise a conductive material, such as doped silicon, permitting it to function as a gate electrode. A spaced-apart pair of contacts 310, 312 (e.g., Ti/Au layers) are disposed in communication with SWNT channel 306. Circuitry 322 preferably includes controllable voltage sources 313 and 324 to regulate V_{sd} between contacts 31-312 and V_g applied at 314 to control the voltage of the substrate/back gate. As in the case of the sensor of FIG. 1, a number of alternative configurations are possible without departing from the spirit of the invention.

[0213] In the example shown, SWNT channel 306 is covered or passivated with thin a dielectric coating 318 which may comprise Al_2O_3 , ZrO_2 or the like, either alone, in mixtures, or in a multilayer coating. Coating 318 is preferably

deposited by ALD and may be only a few nanometer in thickness (e.g., between about 10 and about 100 nm). A functionalization layer **320** is deposited above coating **318**, and may comprise one or more of the materials listed in Table 3 above. In a preferred example, layer **320** may comprise glycerol, alone or in combination with a surfactant such as Triton **100**.

[0214] A number of different measurement schemes may be advantageously applied in ammonia detection using sensor device **251**. For example, temperature and humidity dependence of the device may be reduced by heating sample **255** to a temperature above the ambient (e.g. between about 60 and about 70° C.).

[0215] In one exemplary measurement protocol, the substrate gate or “back gate” **304** is grounded and a DC bias-voltage V_{sd} is applied between the source **310** and drain **312**, so as to generate a measurable current through channel **306**, permitting the determine of conductance or resistance as a function of exposure to medium **255** and/or as a function of time.

[0216] In an alternative measurement protocol, the V_g of the backgate **304** is modulated with a voltage waveform produced by circuitry **322**. This waveform may have a particular shape (e.g., sin wave, triangle wave, square wave, etc), a particular amplitude (e.g., 1 mV peak-to-peak, 1 V peak-to-peak, 10 V peak-to peak, etc), a particular offset (e.g., -1 V, 0V, +1 V, etc), and/or a particular frequency (e.g., 0.1 Hz, 1 Hz, 10 Hz, etc). The conductance or other properties may then be measured at one point, or at multiple points during the gate-waveform. This protocol may produce measurements with increased stability.

[0217] In an additional alternative measurement protocol, the AC gate voltage is applied to gate **304** as described above, and in addition a waveform AC-bias V_{sd} is applied between the source **310** and drain **312**, and measurements of conductance or other properties is likewise taken at selected points within the V_{sd} waveform.

[0218] The employment of AC waveforms for V_g and/or V_{sd} can permit much faster response and recovery of sensor response. Such measurement protocols may stabilize the device and also reduce such effects as charge migration, electrochemical reactions, or other phenomena. Such AC measurement protocols can permit other parameters to be measured simultaneously (e.g., RH, temperature, and the like) which can then used in compensation algorithms to improve measurements of analyte concentrations

[0219] In addition, global changes of the conductance response to V_g (“ I/V_g ”) may be tracked. For example, 1) electron transfer shifts the I/V_g left or right along the gate-voltage axis, 2) charge-carrier scattering scales the I/V_g in the “conducting” region, 3) changes at any ohmic contact shifts the I/V_g up or down along the conductance axis. There are likely to be many more global changes than those listed here. A number of analog, digital, and/or software algorithms may be used to track such global changes. This information may be employed to increase the accuracy and precision of measurements, among other things.

[0220] Having thus described a preferred embodiment of nanostructures with electrodeposited nanoparticles, and methods of making them, it should be apparent to those skilled in the art that certain advantages of the within system have been achieved. It should also be appreciated that various modifications, adaptations, and alternative embodiments thereof may be made within the scope and spirit of the present

invention. For example, specific examples have been illustrated for nanotube film nanostructures, but it should be apparent that the inventive concepts described above would be equally applicable to other types of nanostructures. The invention is further defined by the following claims.

1. A nanostructure sensor for sensing an analyte of interest in a sample, comprising:

- a substrate;
- a nanostructured element disposed adjacent to the substrate;
- one or more conducting elements in electrical communication with the first nanostructure;
- at least one functionalization operatively associated with the nanostructured element, the at least one functionalization configured to provide sensitivity for the analyte of interest, and
- a processor comprising instructions for (a) selectively exposing at least a portion of a sensor to the environment so that the sensor portion is exposed only intermittently and (b) dynamically sampling a response signal output from the sensor to determine the presence or concentration of the analyte by analysis of the dynamically sampled signal.

2. A sensor as in claim **1**, wherein the nanostructured element includes a network of carbon nanotubes disposed adjacent the substrate.

3. A sensor as in claim **2**, wherein the analyte of interest includes ammonia.

4. A sensor as in claim **2**, wherein the at least one functionalization includes an organic recognition material.

5. A sensor as in claim **4**, wherein the organic recognition material includes a polymer.

6. A sensor as in claim **5**, wherein the polymer includes at least one of a conductive polymer and a semi-conductive polymer.

7. A sensor as in claim **4**, wherein the organic recognition material includes PABS.

8. A sensor as in claim **4**, wherein the organic recognition material includes a non-ionic surfactant.

9. A sensor as in claim **4**, wherein the organic recognition material includes glycerol.

10. A sensor as in claim **4**, wherein the network includes at least one SWNTs which is stably associated with the organic recognition material prior to formation of the network.

11. A sensor as in claim **2**, wherein the at least one functionalization includes an inorganic recognition material.

12. A sensor as in claim **2**, wherein the one or more conducting elements includes a spaced-apart pair of conducting elements defining a conduction path through at least a portion of the network.

13. A sensor as in claim **12**, wherein the conduction path includes electrical interconnections between carbon nanotubes.

14. A sensor as in claim **13**, wherein substantially none of the nanotubes are in contact with both of the spaced-apart pair of conducting elements.

15. A sensor as in claim **1**, further comprising a gate electrode configured to electrically influence the nanostructured element.

16. A nanostructure sensor for sensing an analyte of interest, comprising:

- a substrate, the substrate including a generally sheet-like base material and at least one conductor formed on a surface of the substrate;

a network of nanostructures deposited on the substrate so as to contact the at least one conductor, the network being deposited on the substrate subsequent to the forming of the at least one conductor;

a recognition material disposed in association with the network of nanostructures, the recognition material configured to interact with the analyte of interest and

a processor comprising instructions for (a) selectively exposing at least a portion of a sensor to the environment so that the sensor portion is exposed only intermittently and (b) dynamically sampling a response signal output from the sensor to determine the presence or concentration of the analyte by analysis of the dynamically sampled signal.

17. A sensor as in claim **16**, wherein the substrate comprises a flexible polymeric material, and wherein the network of nanostructures includes carbon nanotubes deposited upon the substrate from a liquid suspension.

18. A sensor as in claim **17**, wherein the substrate comprises a flexible polymeric material, and wherein the network of nanostructures includes carbon nanotubes deposited upon the substrate from a liquid suspension.

19. A sensor as in claim **18**, wherein the recognition material is associated with the nanotubes prior to the deposition of the nanotubes from liquid suspension.

20. A sensor as in claim **18**, wherein the sensor includes at least a pair of conductors formed on the substrate in a spaced-apart arrangement, the network of nanotubes configured to electrically communicate between the pair of conductors, and the recognition material configured so that the interaction of the recognition material with the analyte of interest produces a change in the conductivity of the network between the pair of conductors.

21-37. (canceled)

* * * * *