



(19) **United States**

(12) **Patent Application Publication**  
TE et al.

(10) **Pub. No.: US 2016/0052016 A1**

(43) **Pub. Date: Feb. 25, 2016**

(54) **METHOD AND APPARATUS FOR  
SIMULTANEOUSLY SCRIBING AND FILLING  
OF SCRIBED CHANNEL, TROUGH, TRENCH  
OR GROOVE**

(52) **U.S. Cl.**  
CPC ..... *B05D 3/002* (2013.01)

(57) **ABSTRACT**

A combined scribing/filling device for scribing a desired channel, trough, trench or groove in a layer currently being fabricated and simultaneously filling the scribed channel, trough, trench or groove with a desired filling material. The combined scribing/filling device comprises (1) a scribing tool having a scribing tip which facilitates scribing of the desired channel, trough, trench or groove in the layer currently being fabricated; and a dispensing/shaping orifice for filling the scribed channel, trough, trench or groove with the filling material. The scribing tip is located coincident with respect to the dispensing/shaping orifice to facilitate simultaneously scribing and filling of the channel, trough, trench or groove. A method of fabricating a three dimensional model from a composite model formed by a plurality of layers, by simultaneously scribing and filling of the channel, trough, trench or groove is also disclosed.

(71) Applicant: **SOLIDSCAPE, INC.**, Merrimack, NH (US)

(72) Inventors: **Bun Chay TE**, Nashua, NH (US); **John T. WIGAND**, Nashua, NH (US)

(21) Appl. No.: **14/467,679**

(22) Filed: **Aug. 25, 2014**

**Publication Classification**

(51) **Int. Cl.**  
*B05D 3/00* (2006.01)

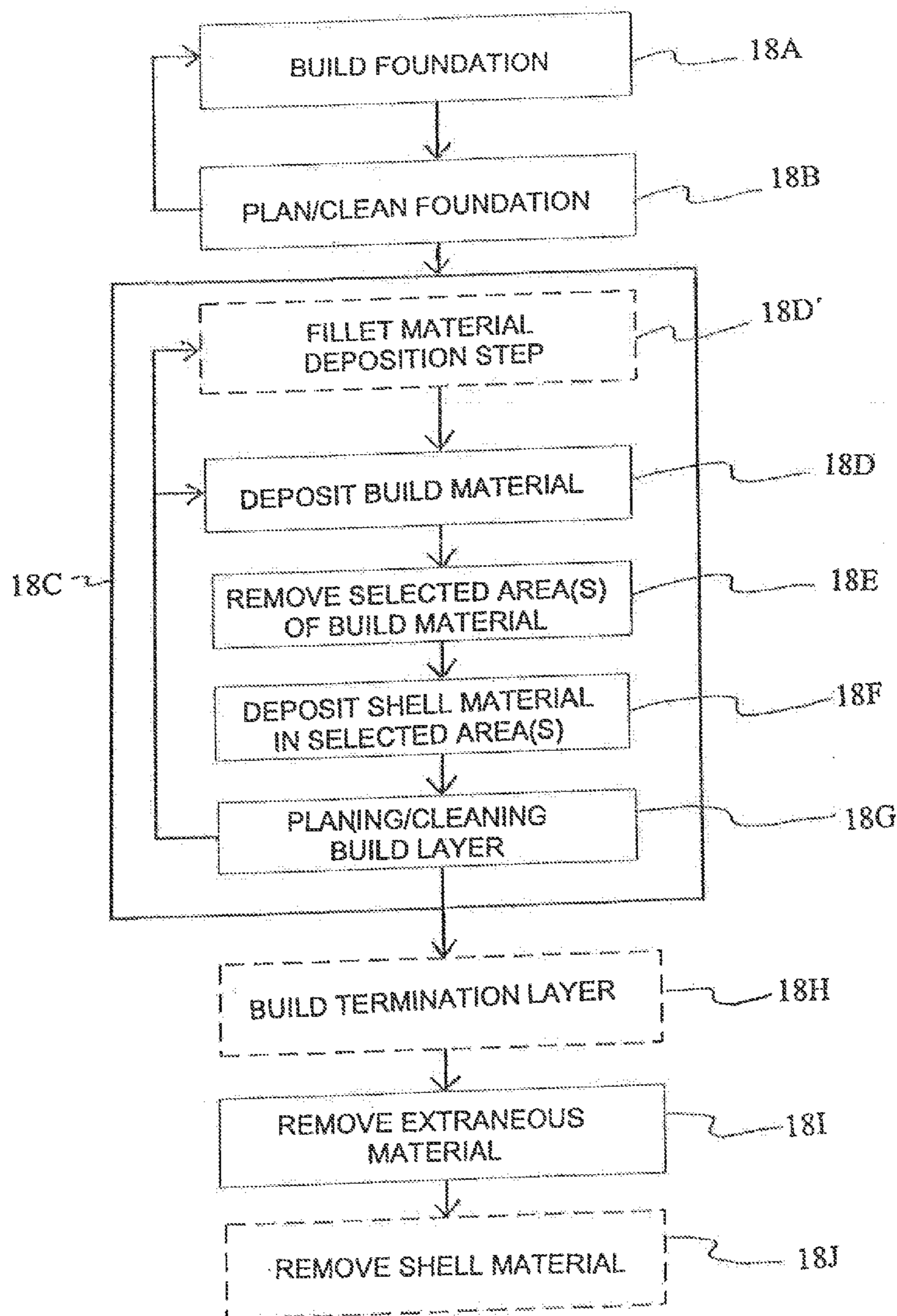

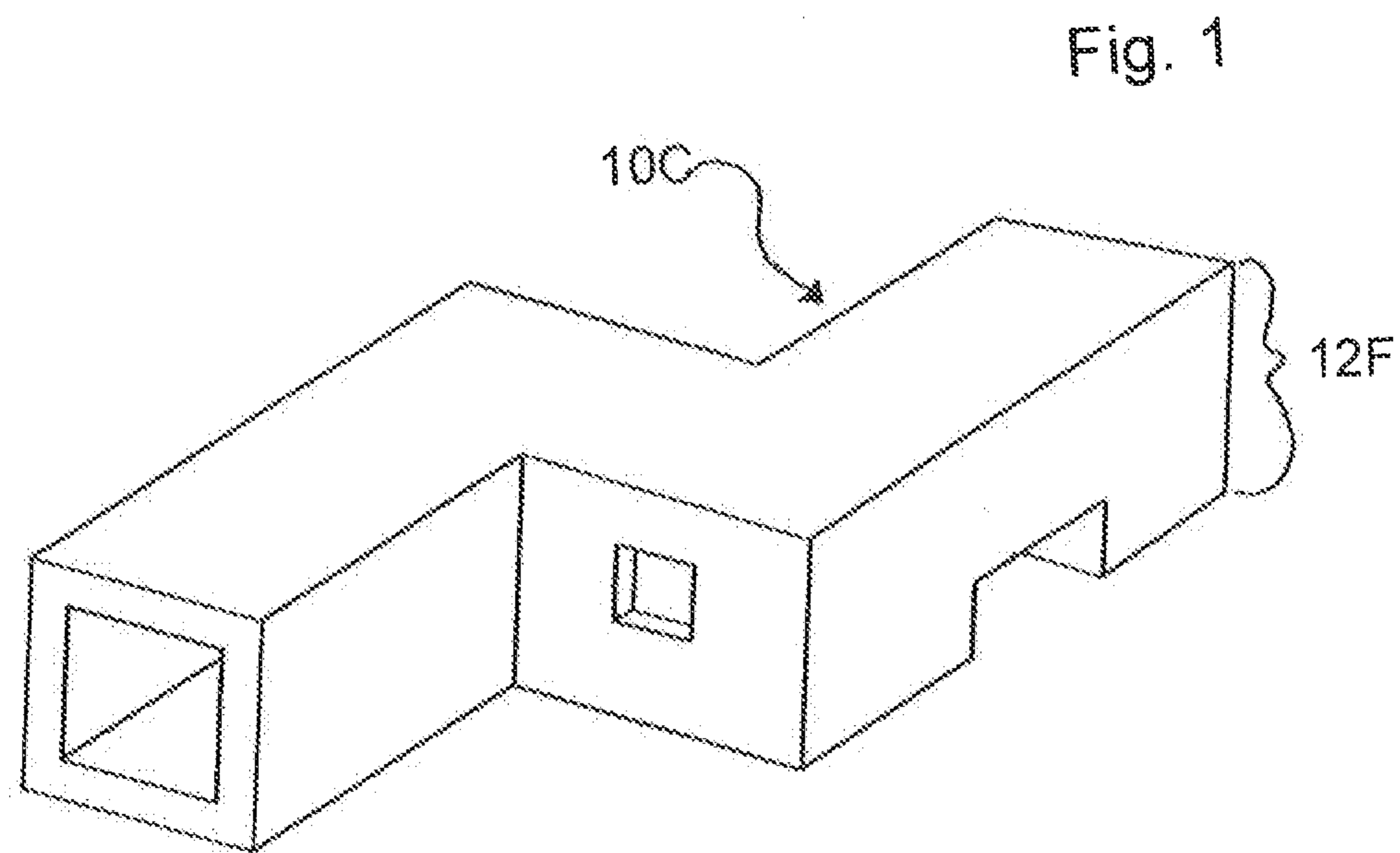

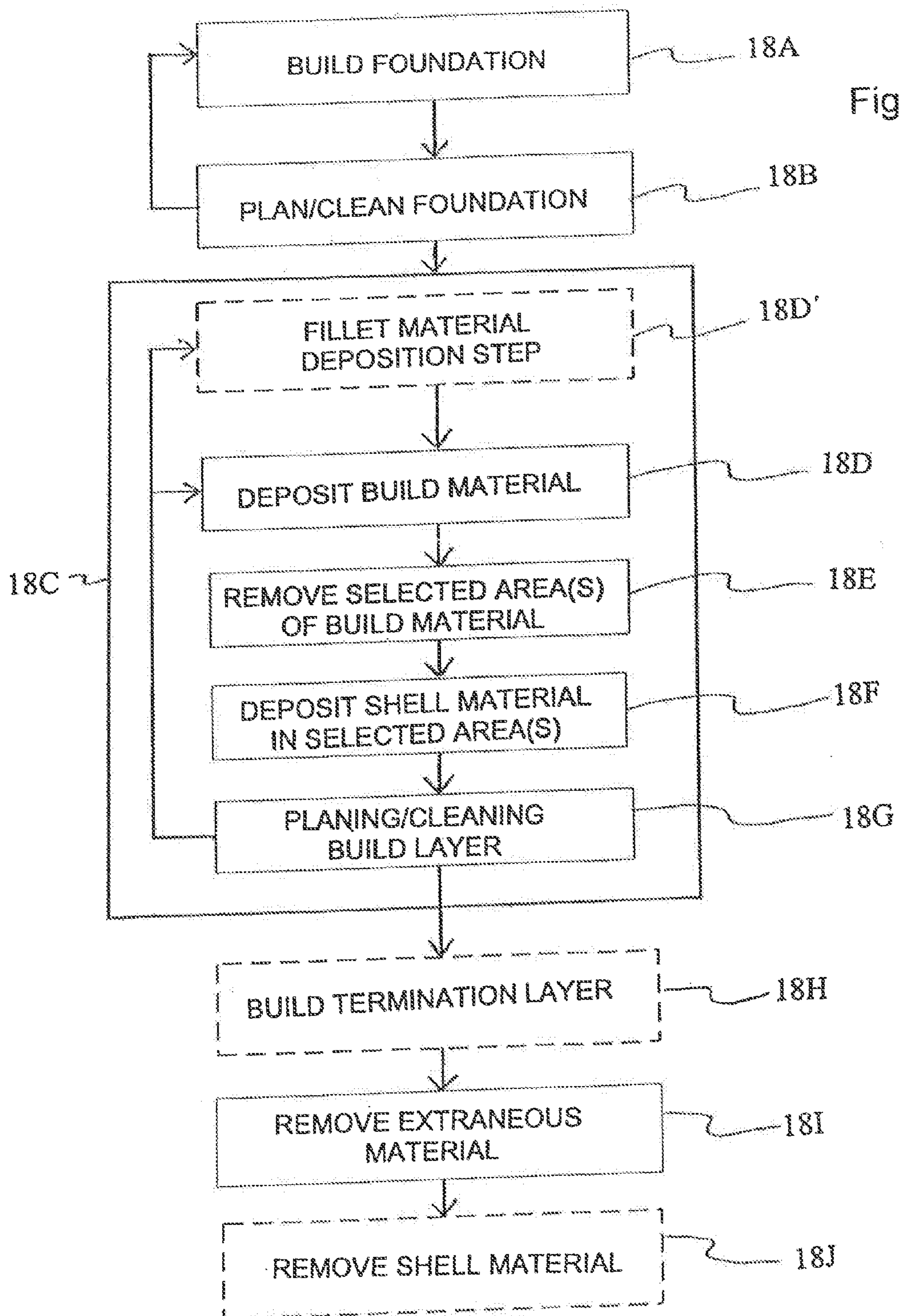

Fig. 1A

Fig. 1B

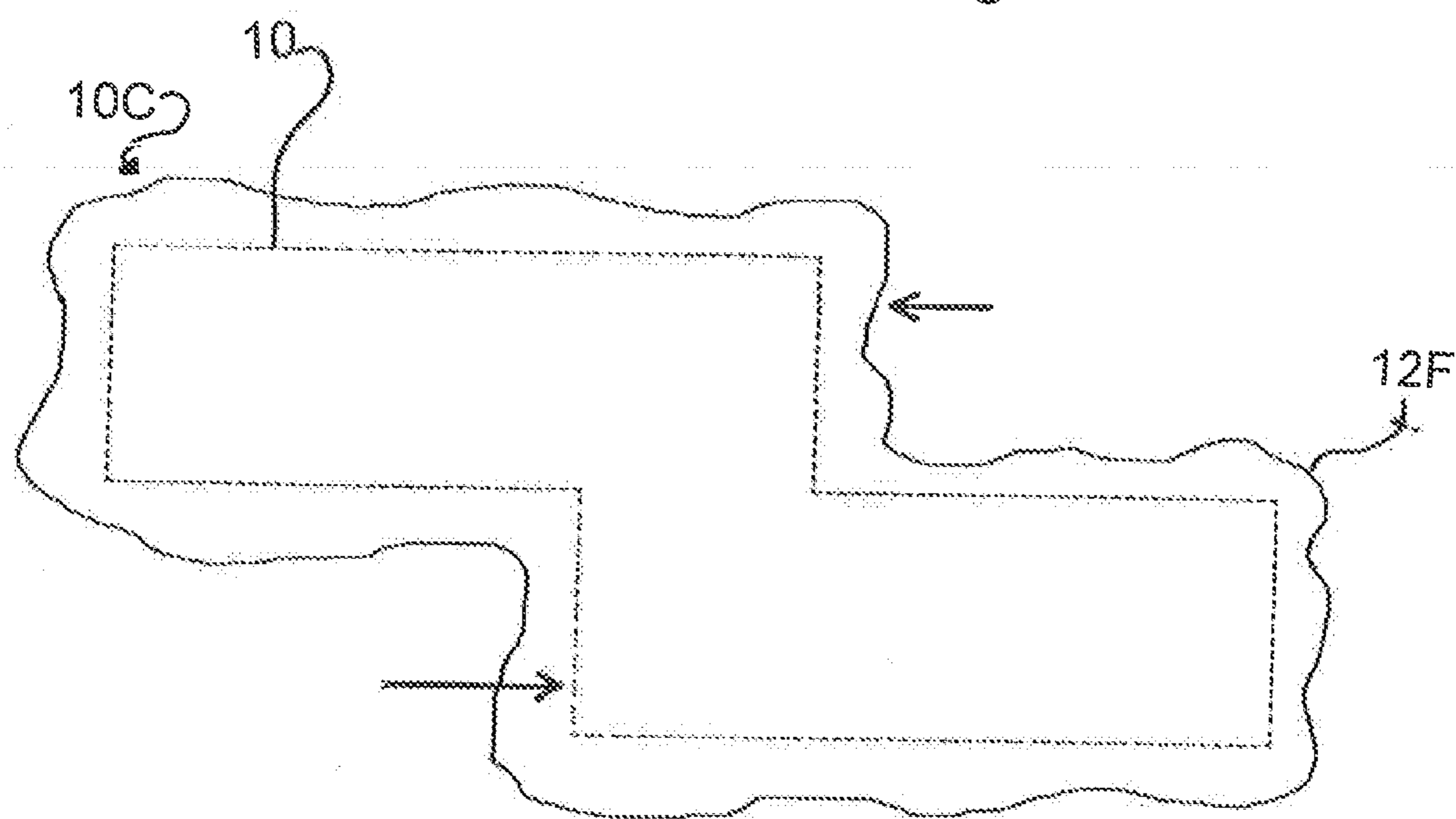



Fig. 1C

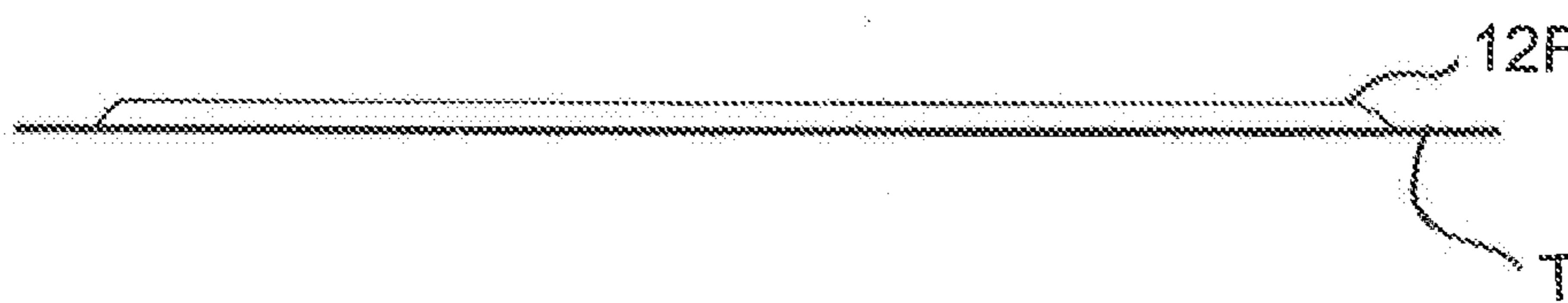

Fig. 1D

Fig. 1E

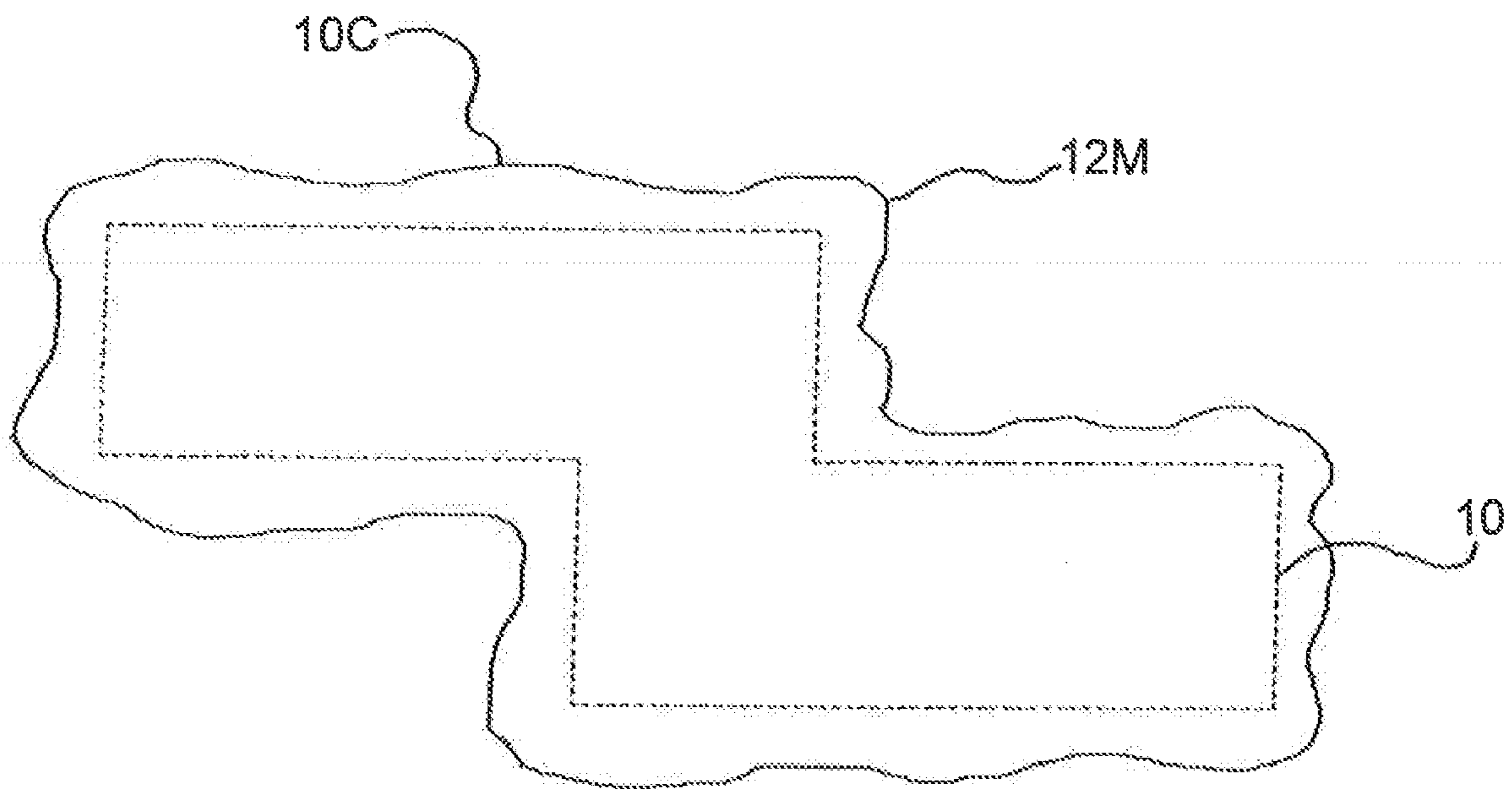

Fig. 1F

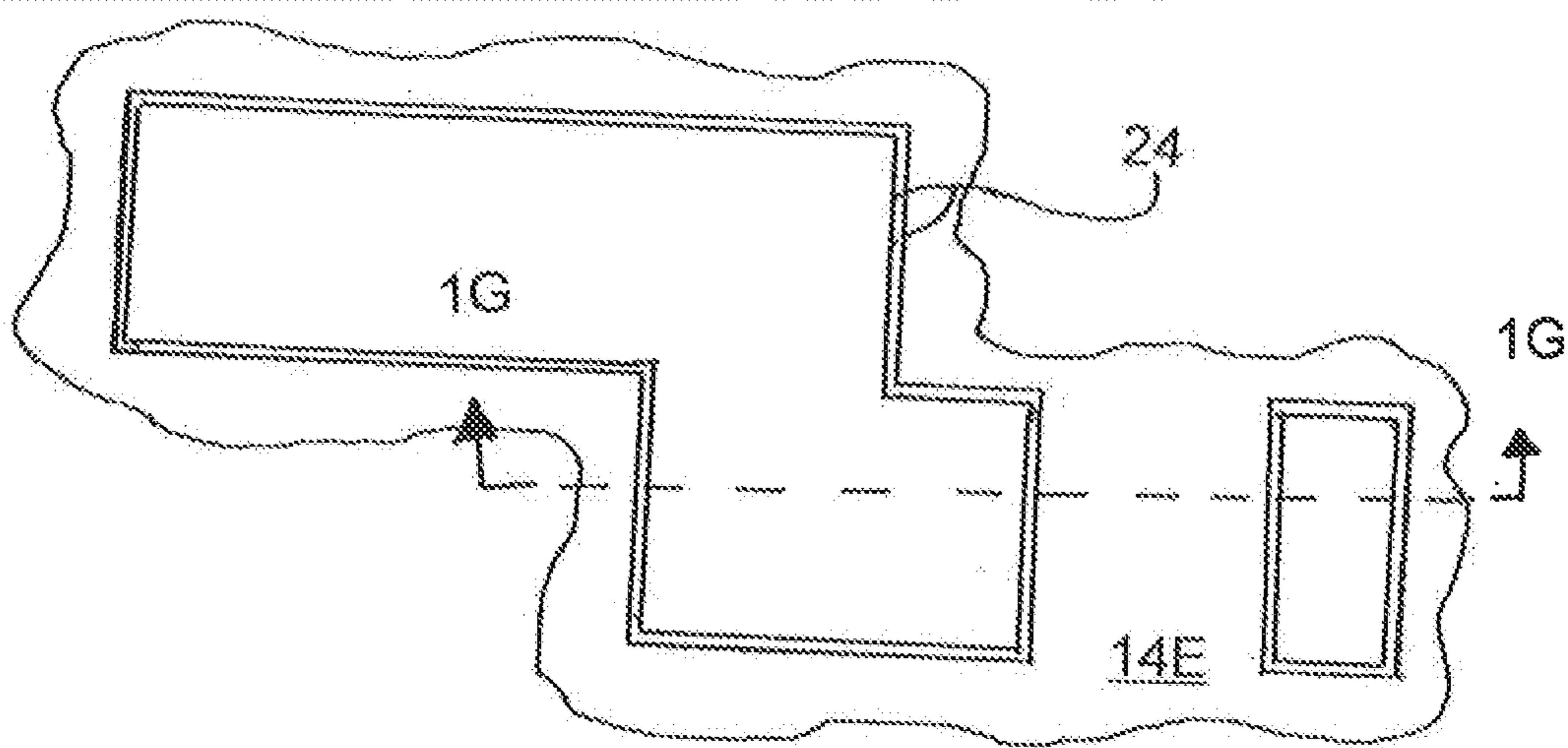

Fig. 1G

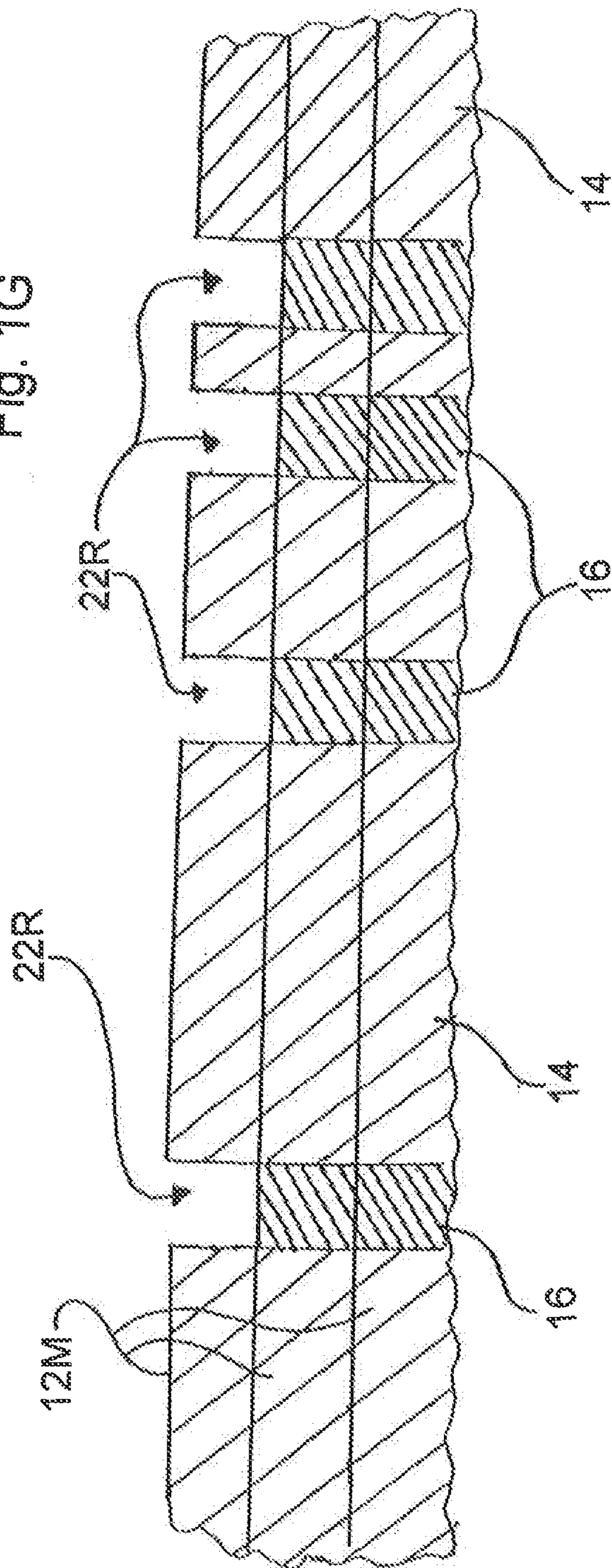
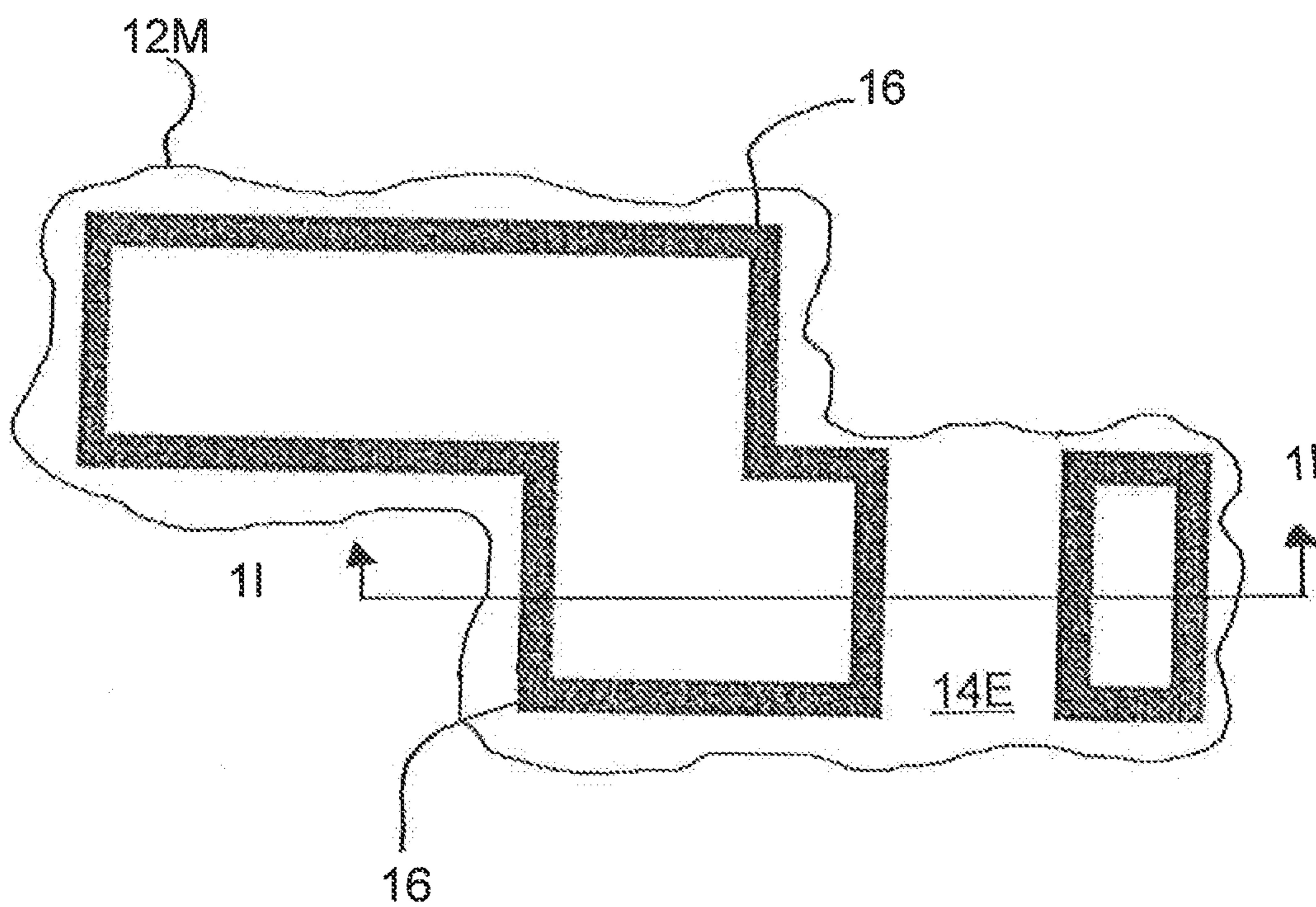



Fig. 1H



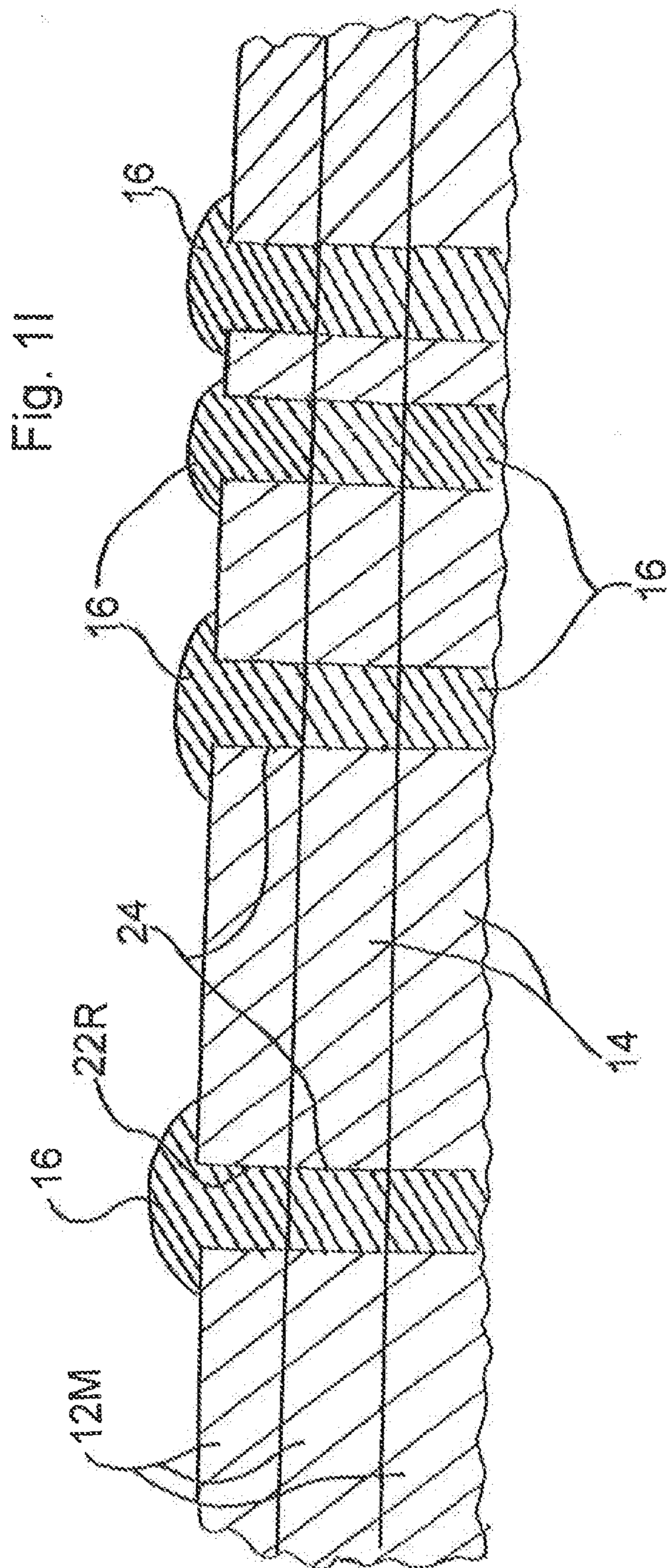

Fig. 1J

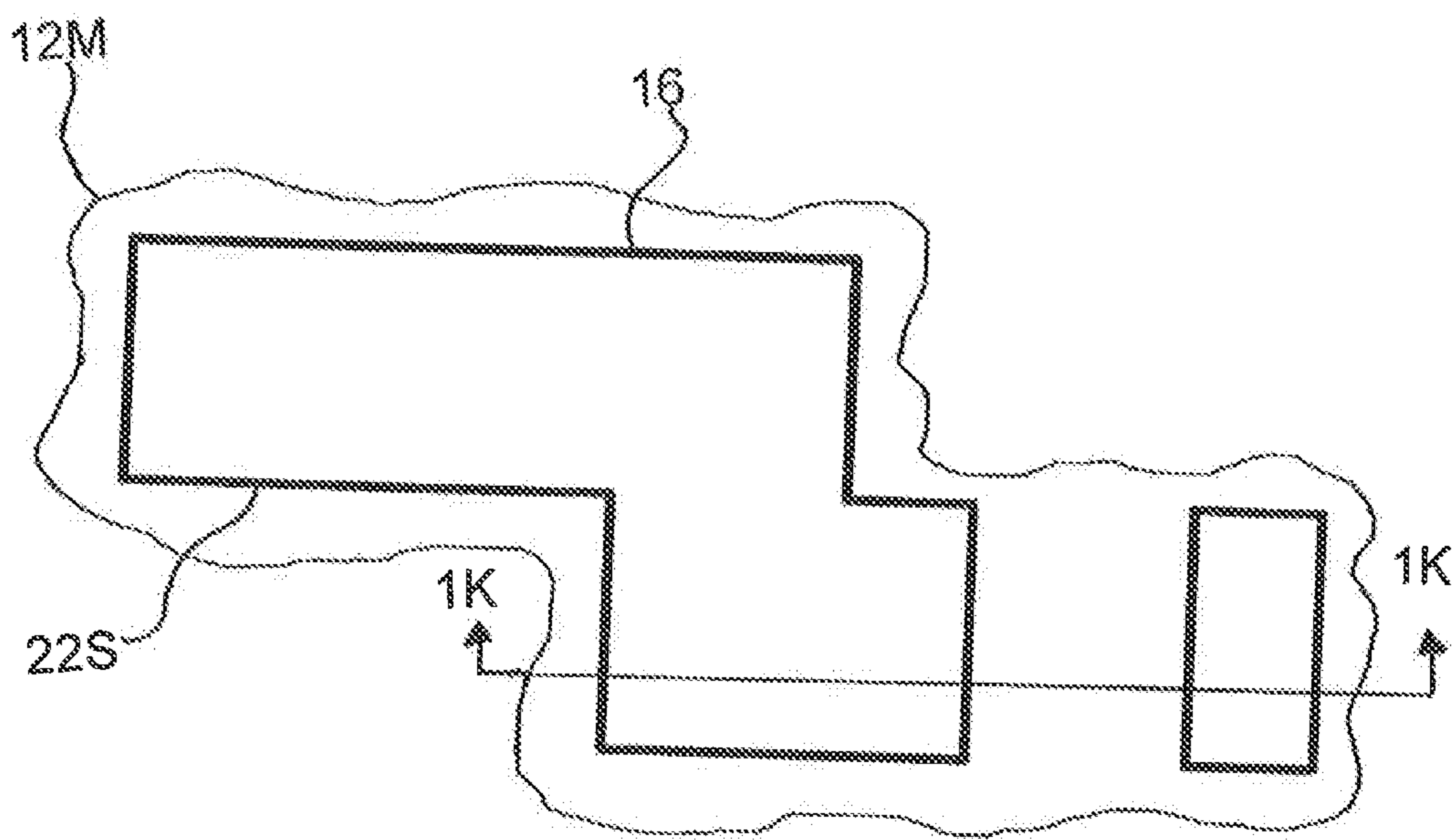
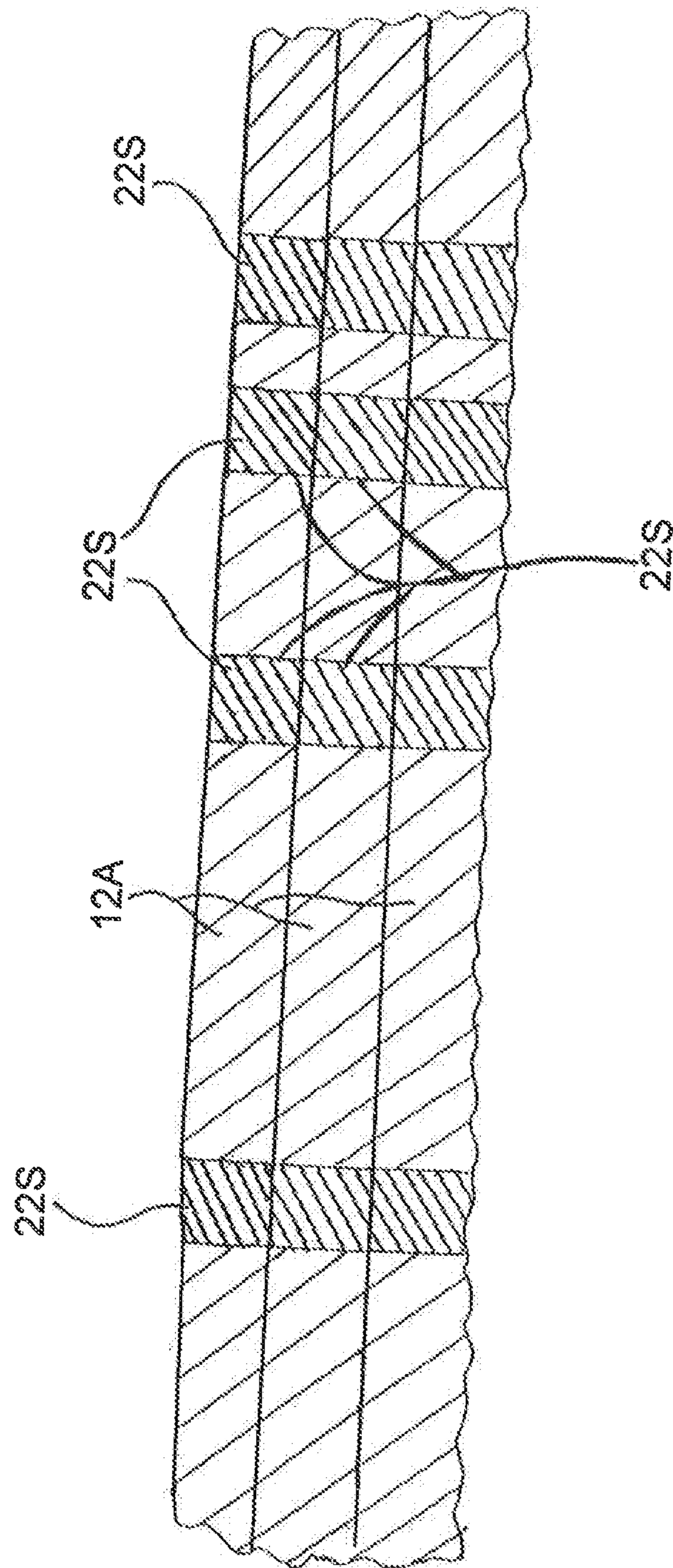
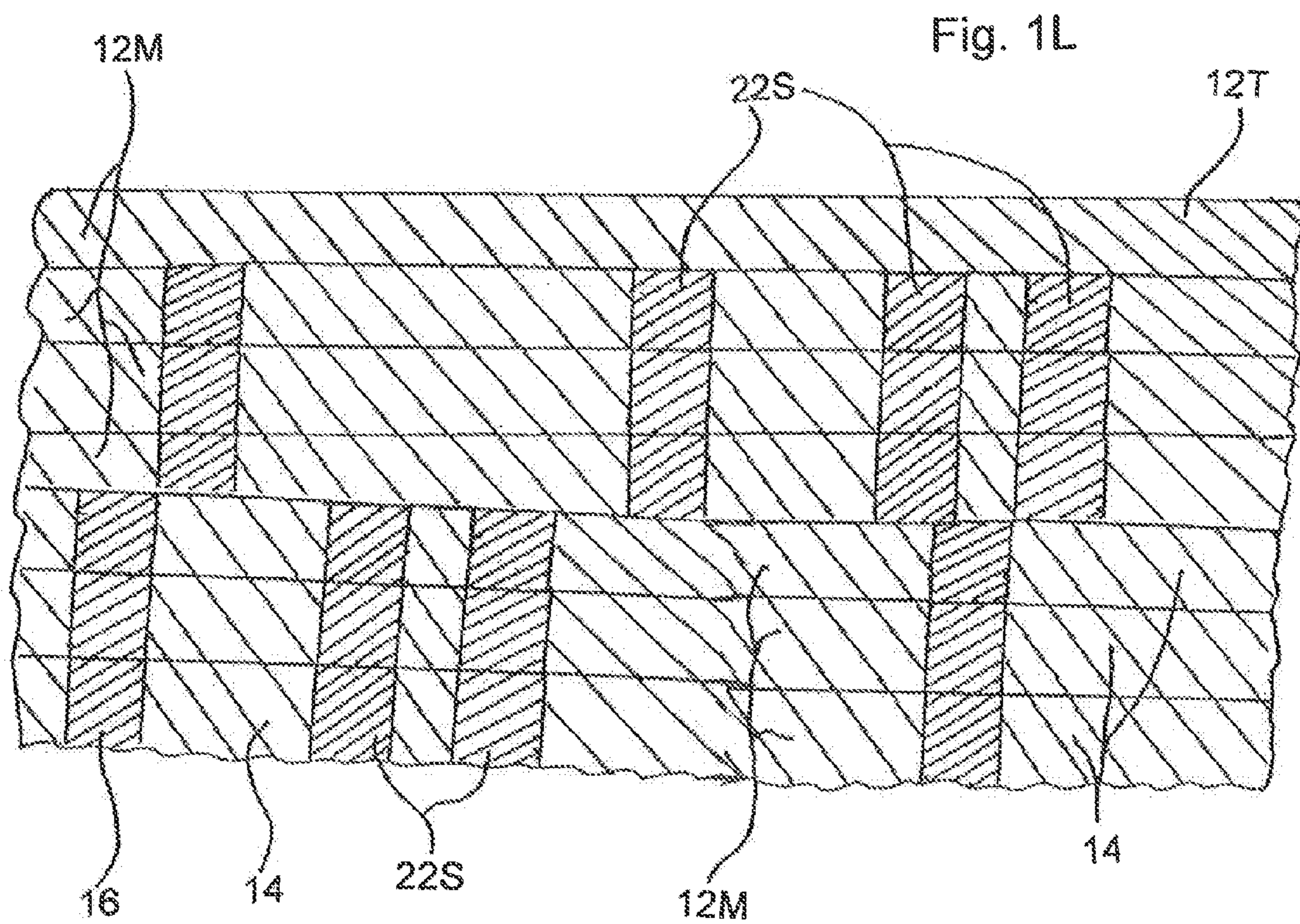

Fig. 1K





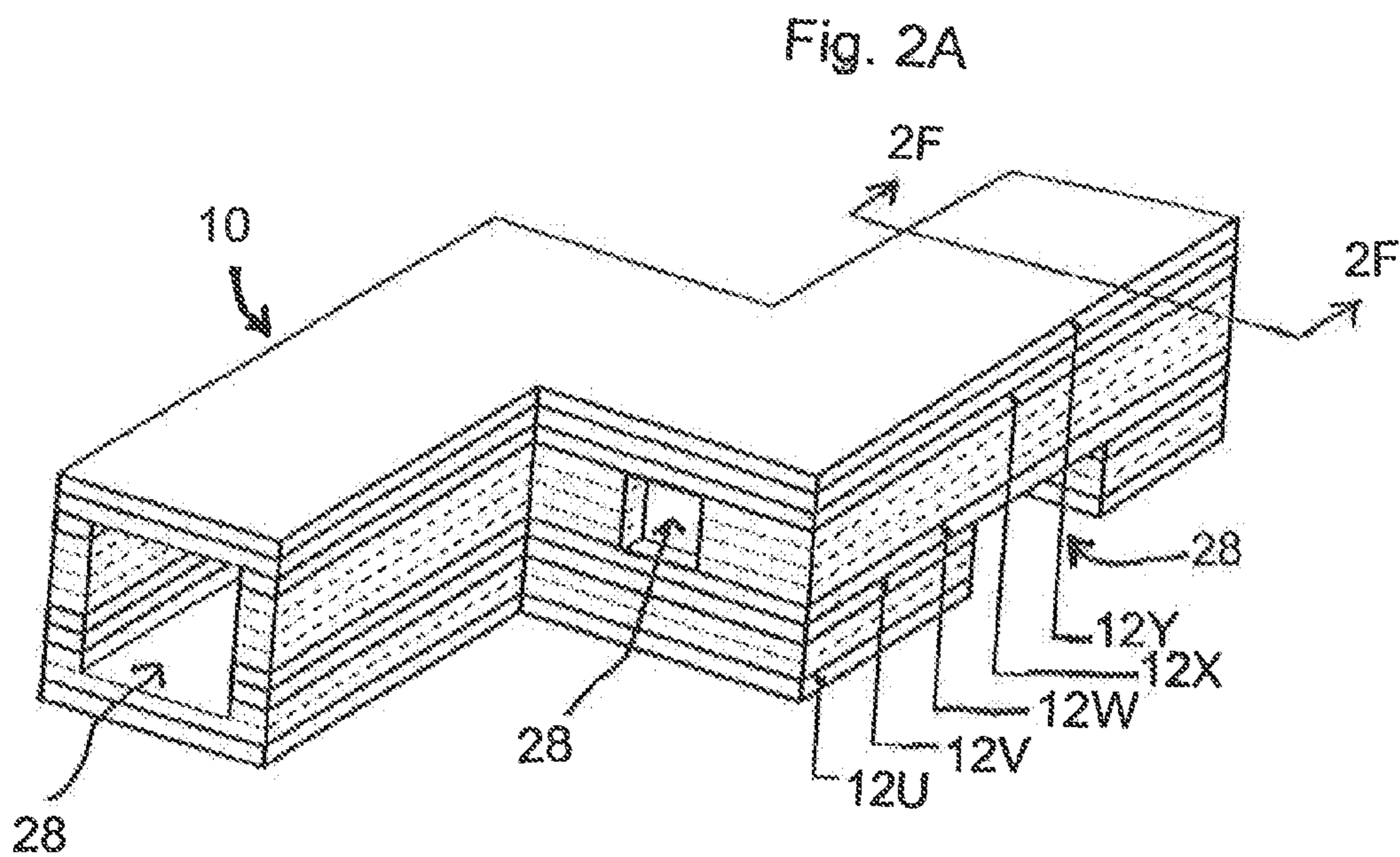

Fig. 2B

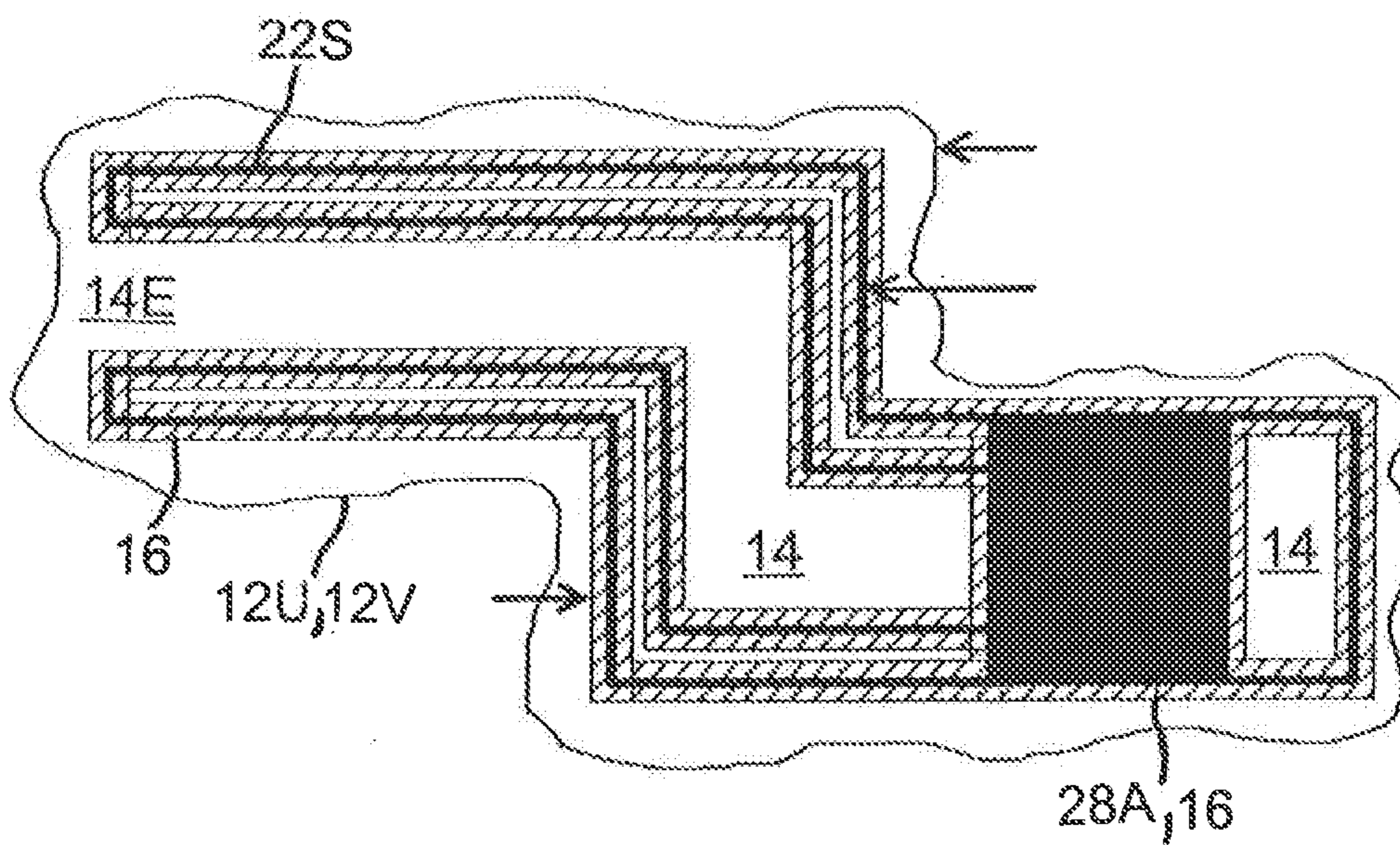

Fig. 2C

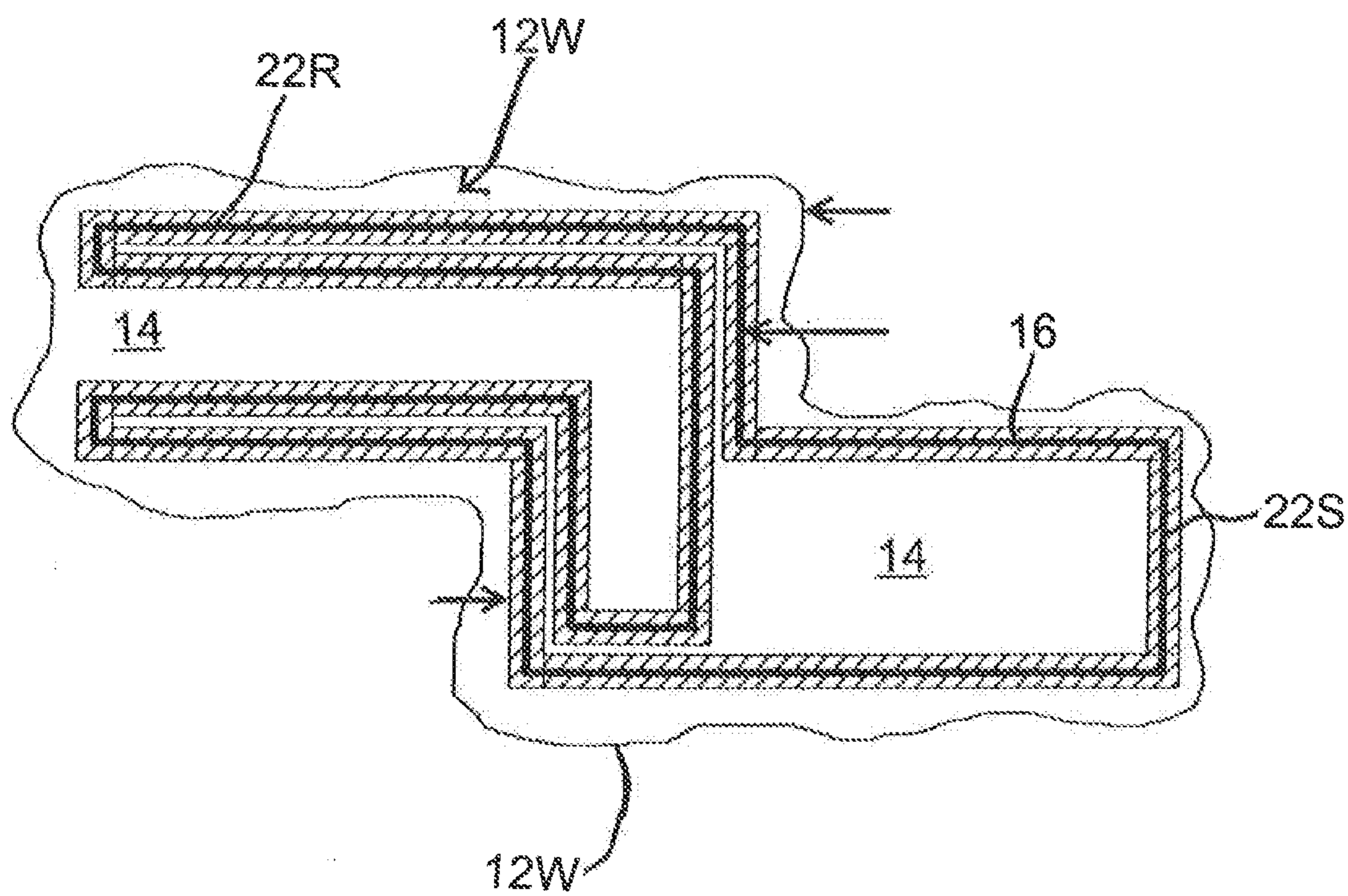



Fig. 2D

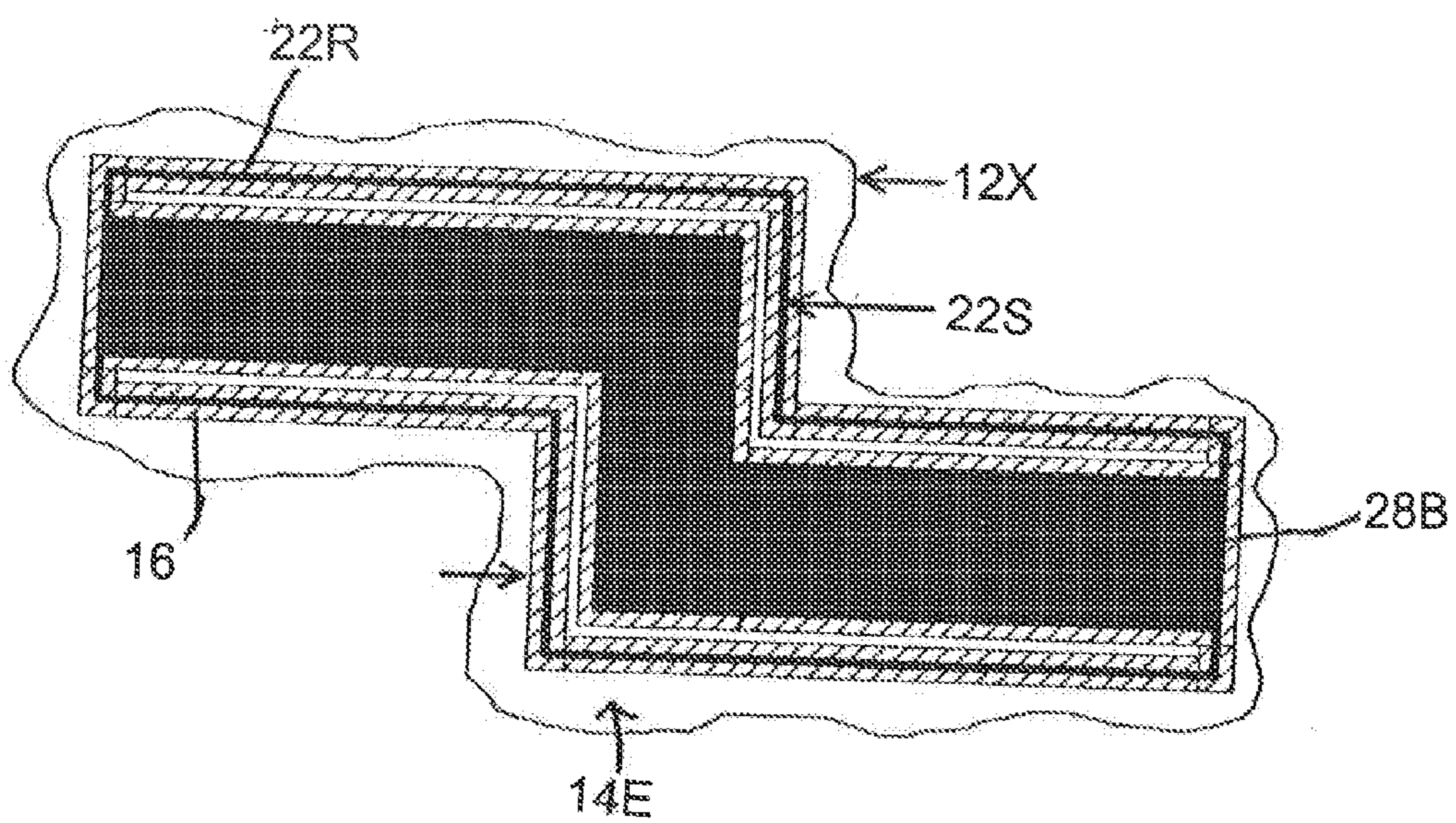
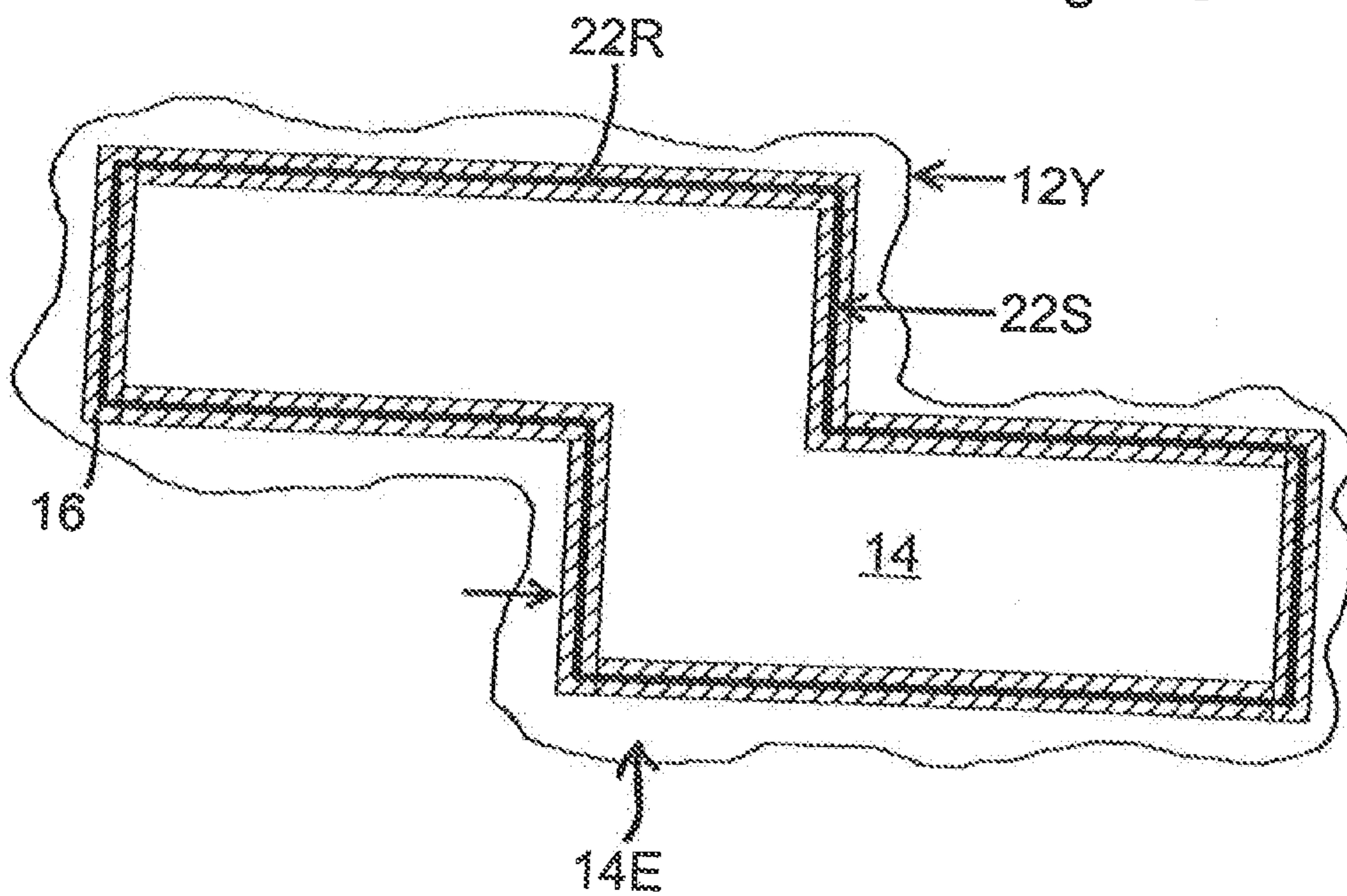

Fig. 2E



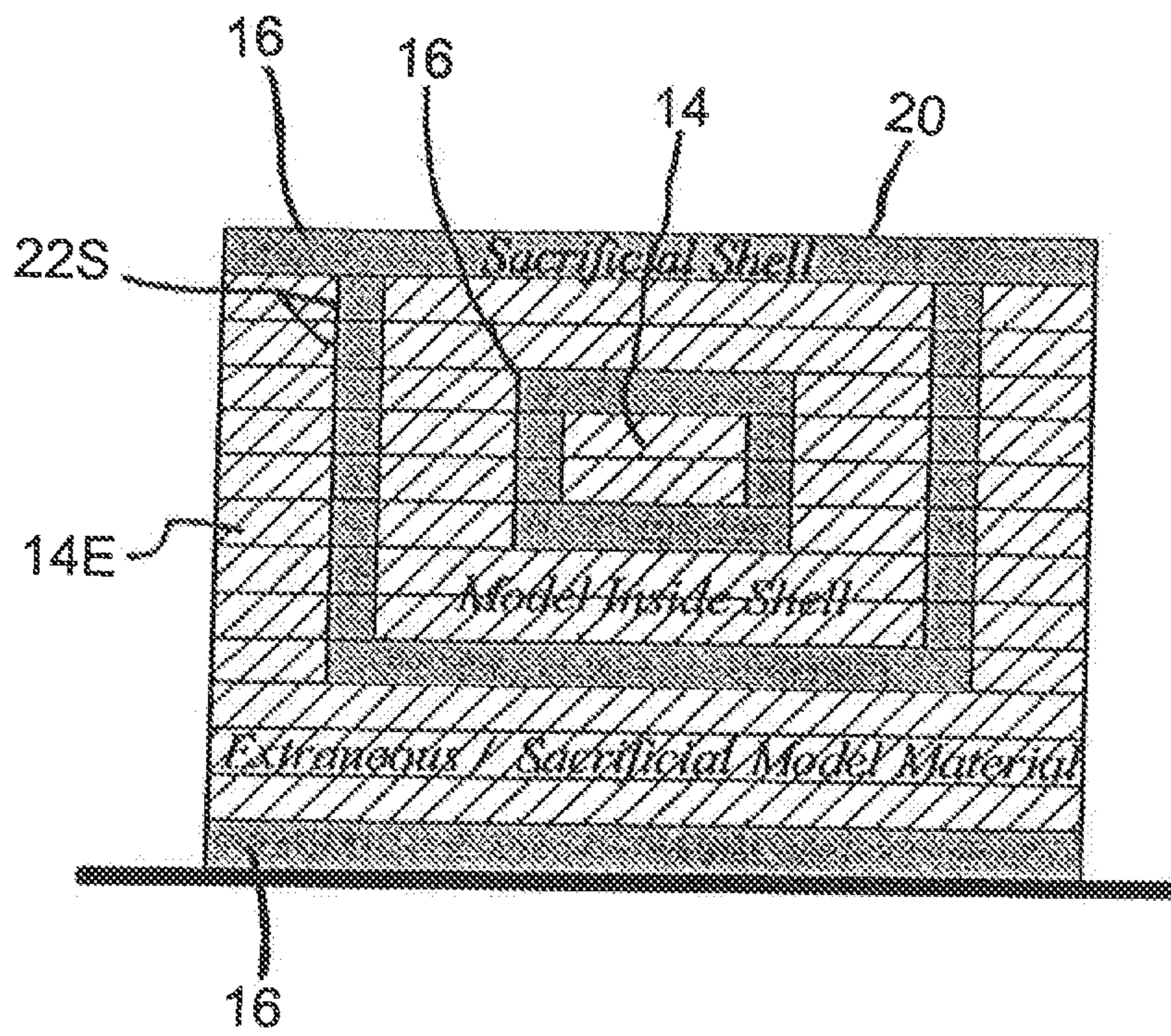

Fig. 2F

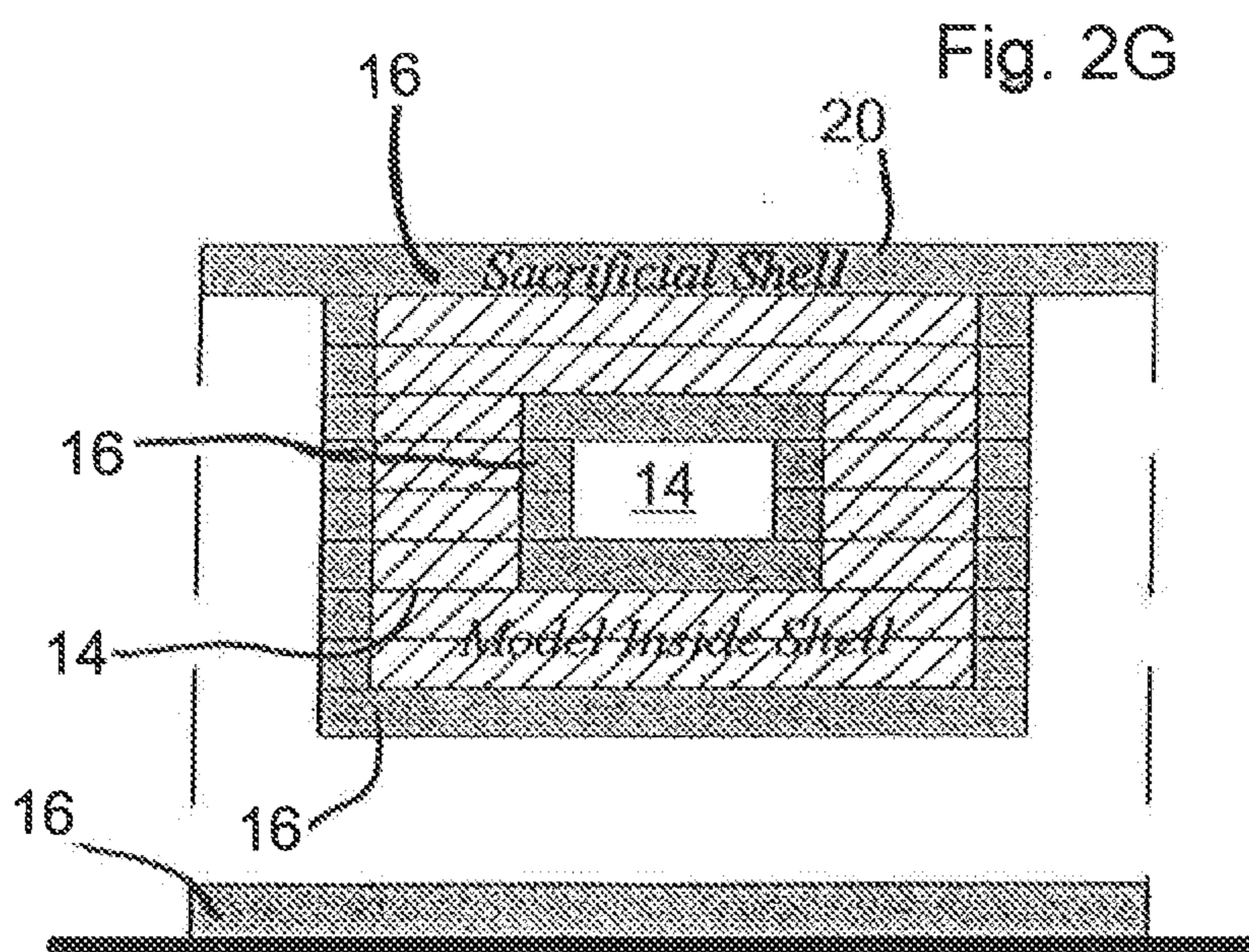

Fig. 2H

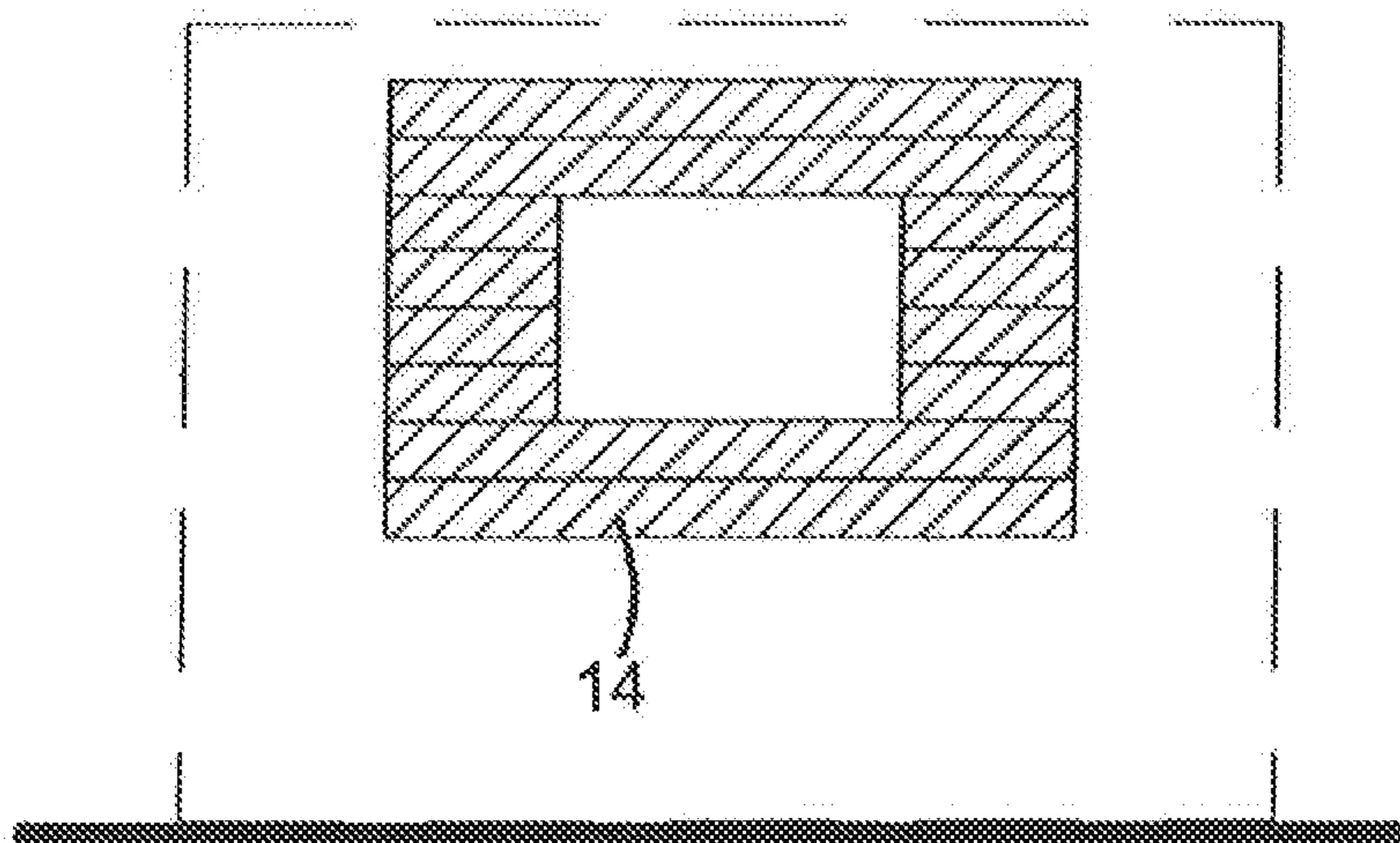
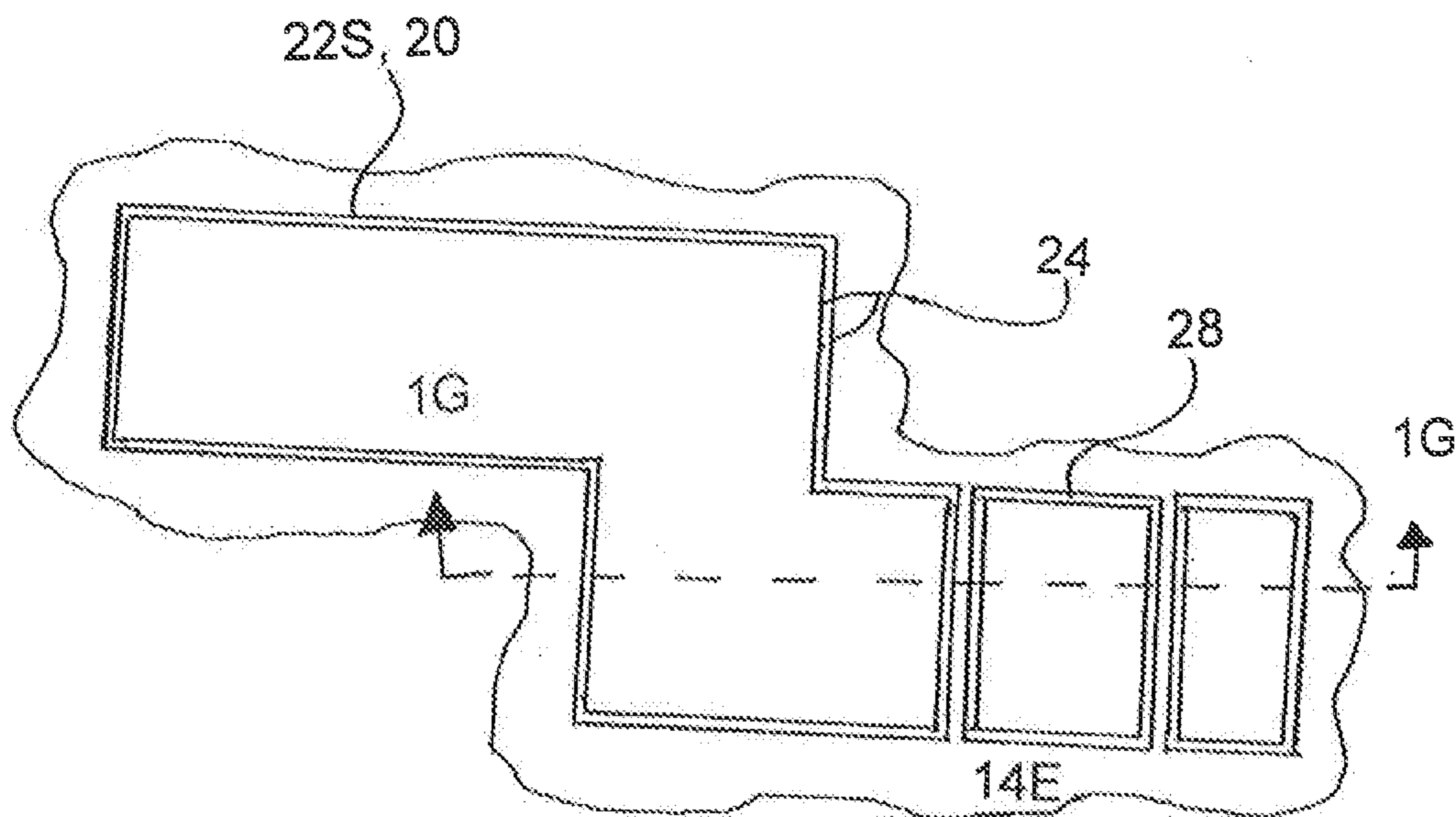

Fig. 3A



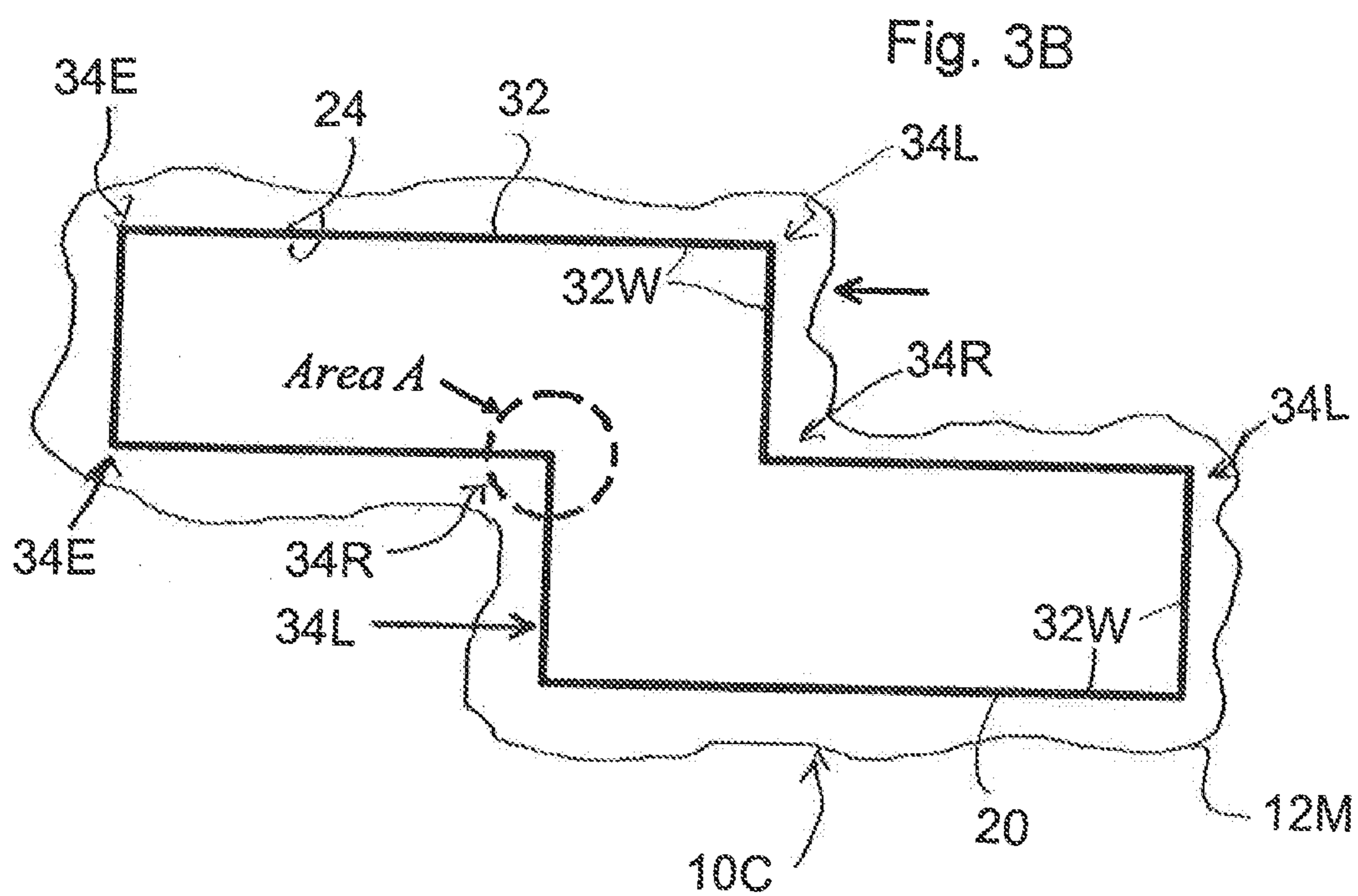

Fig. 3C

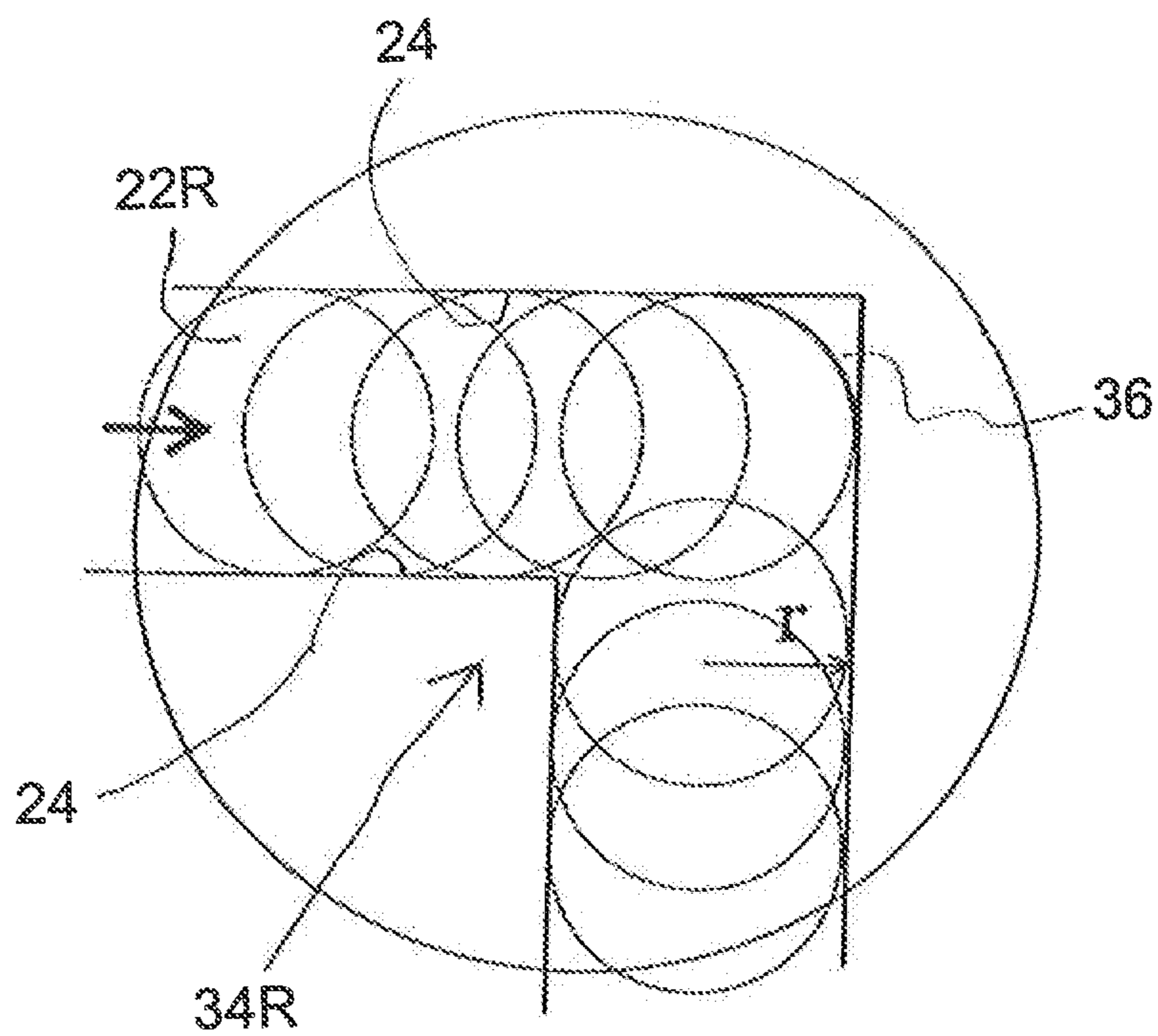
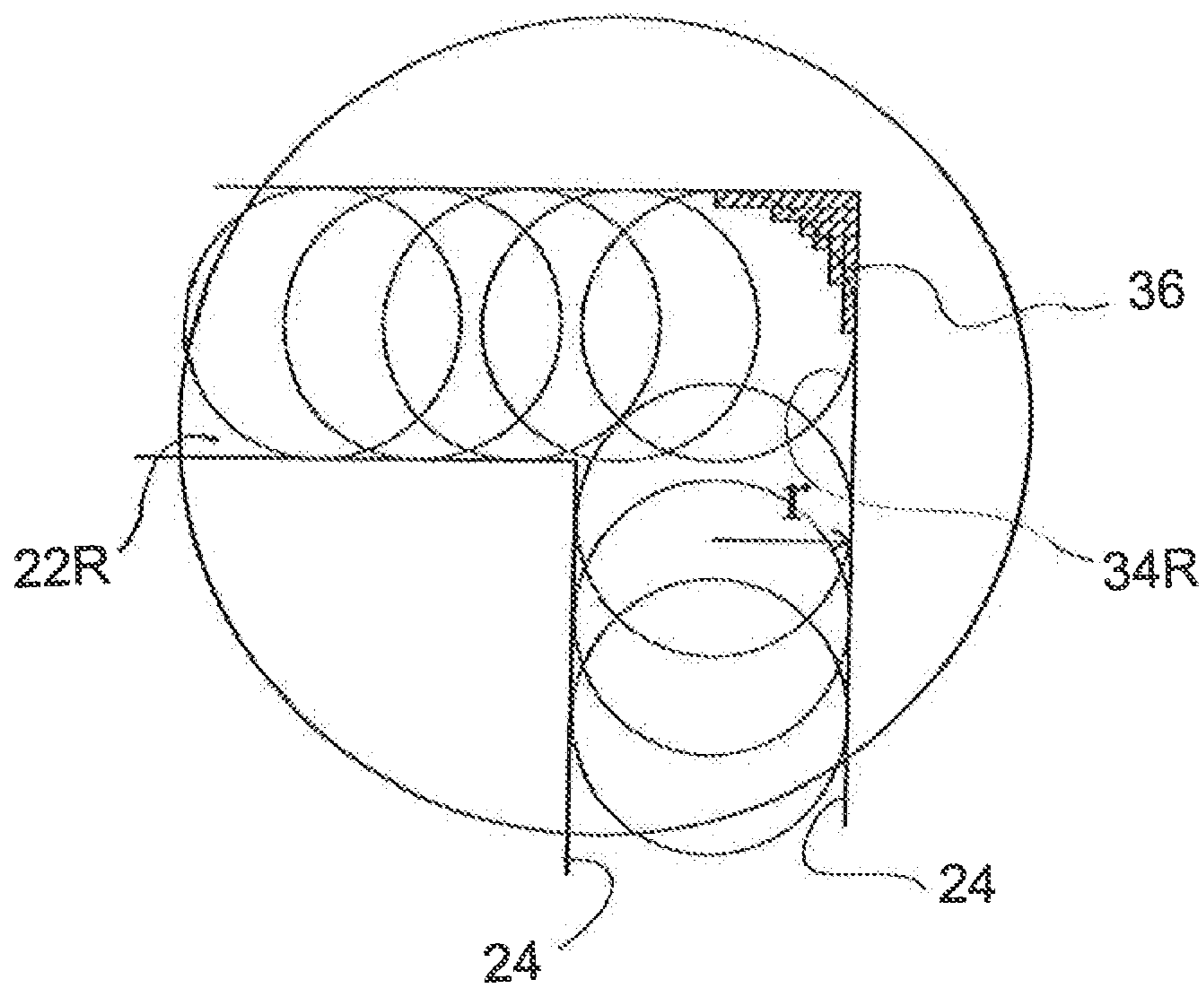



Fig. 3D



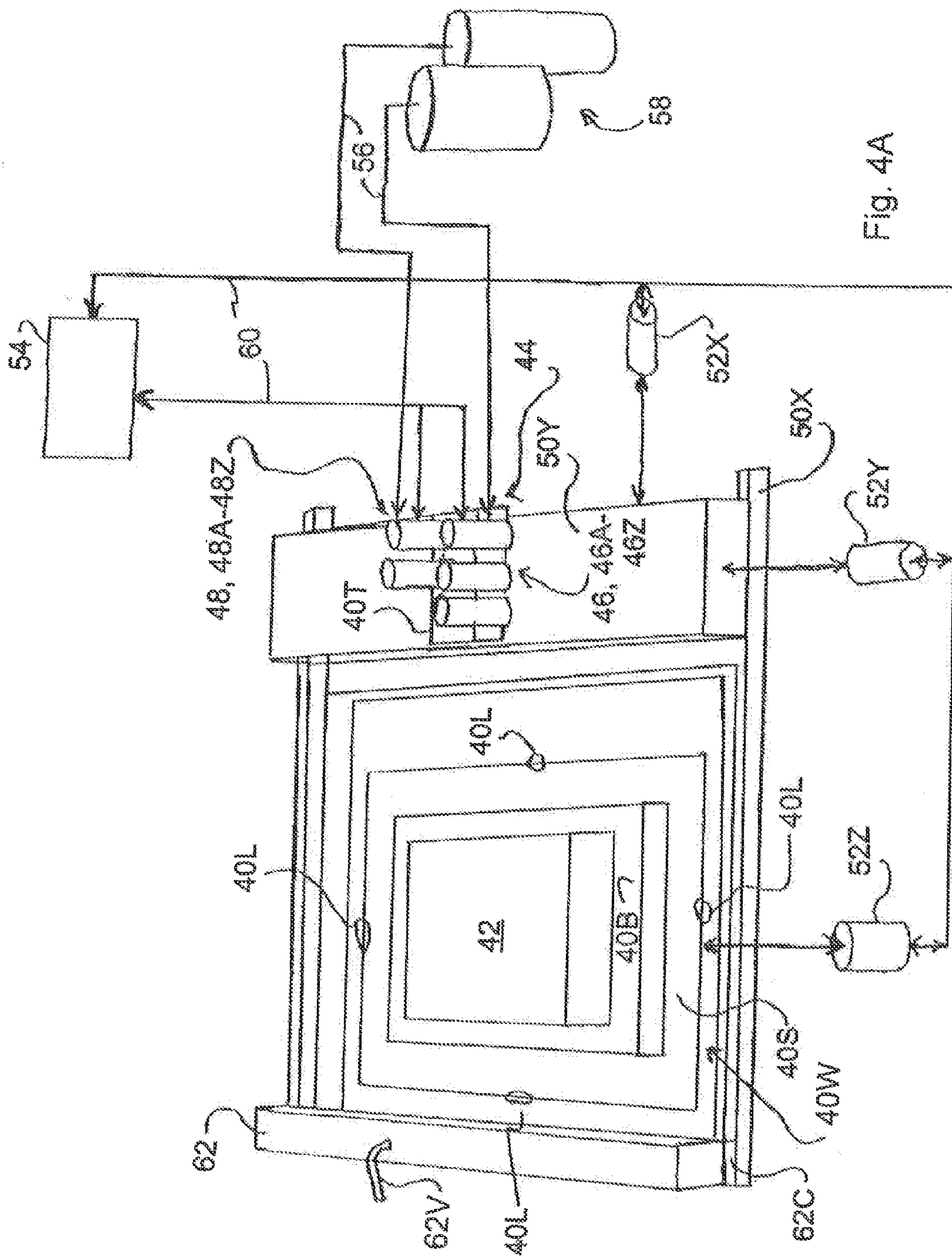

Fig. 4A

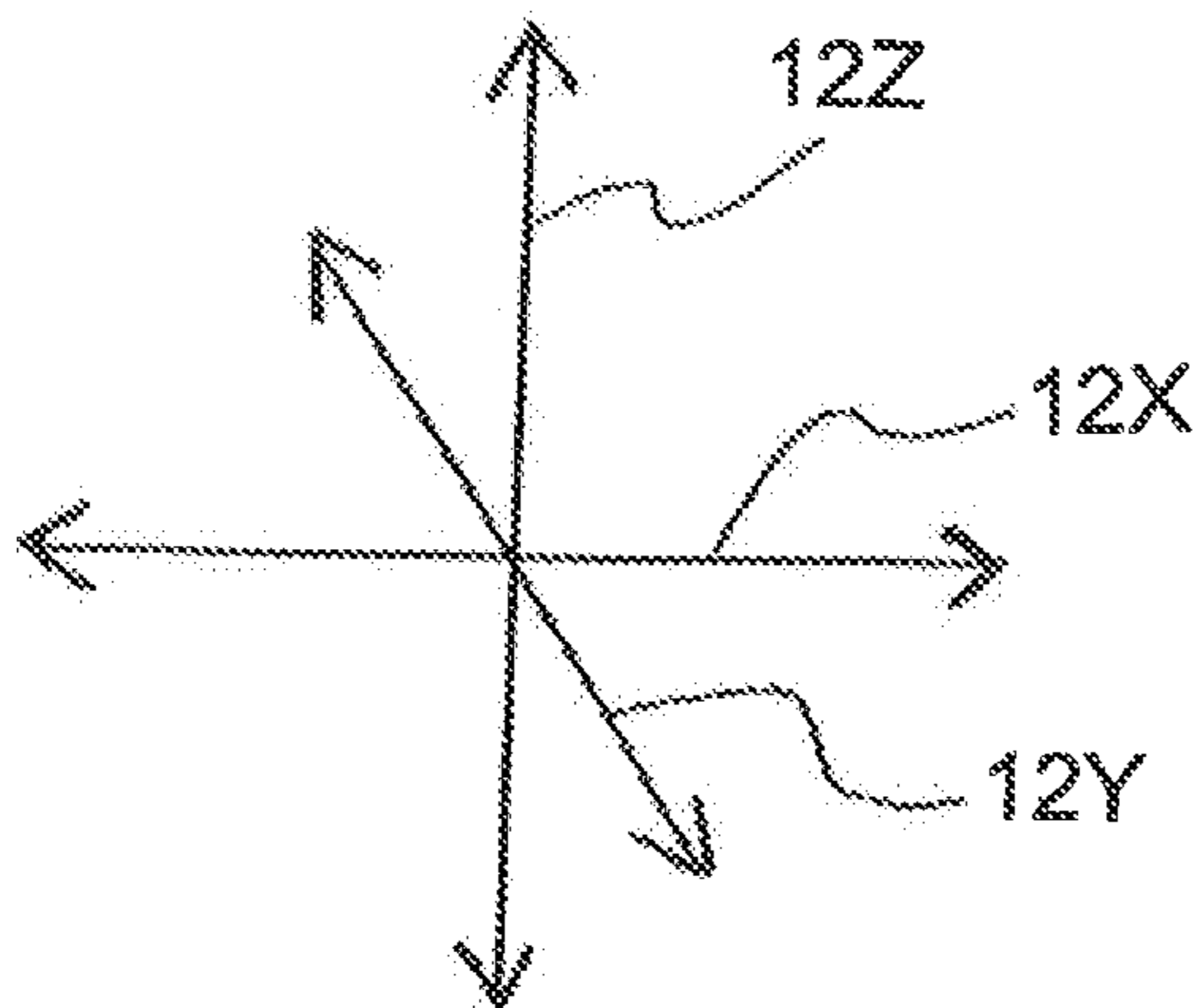

Fig. 4B

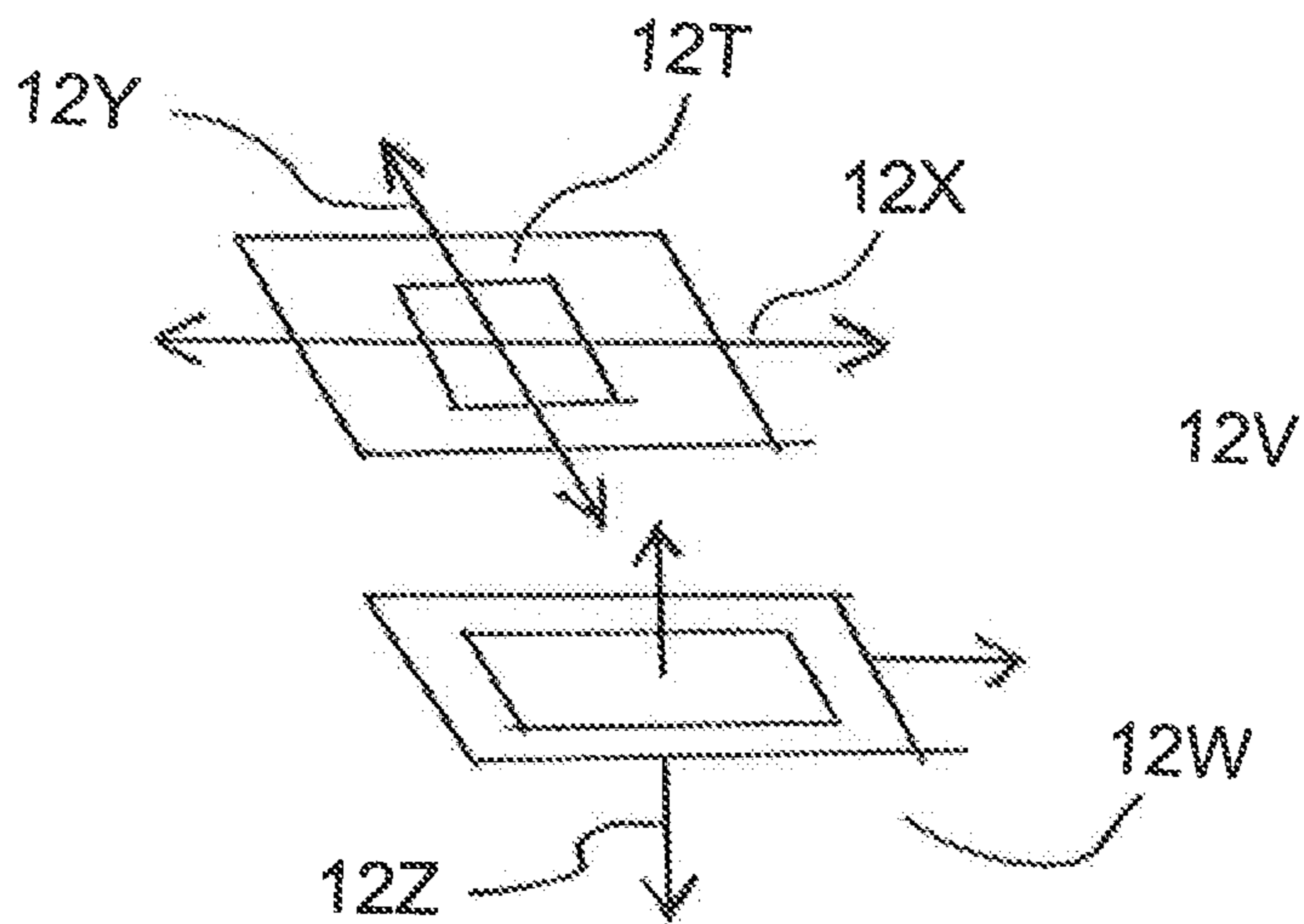

Fig. 4C

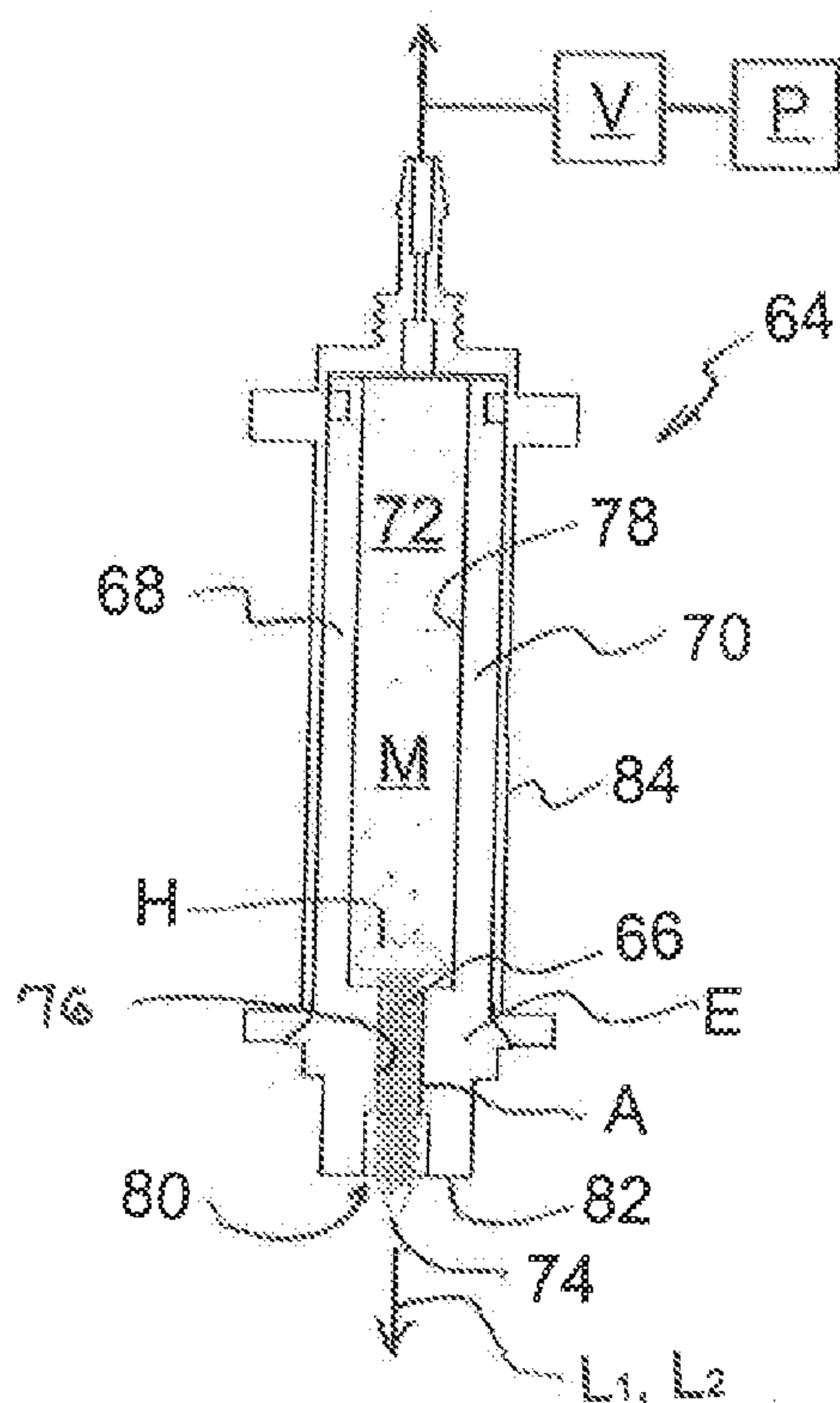

FIG. 5C

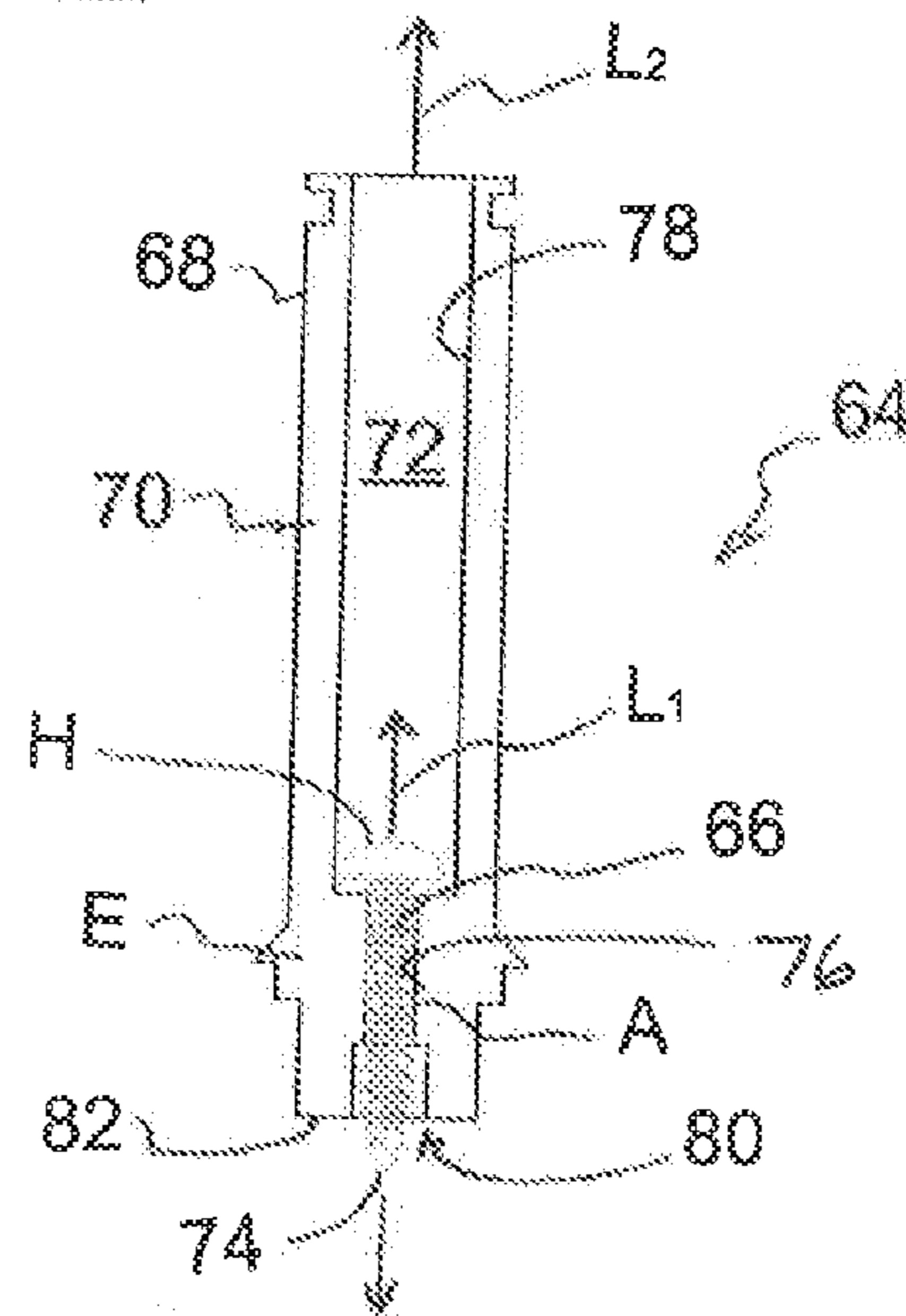

FIG. 5B

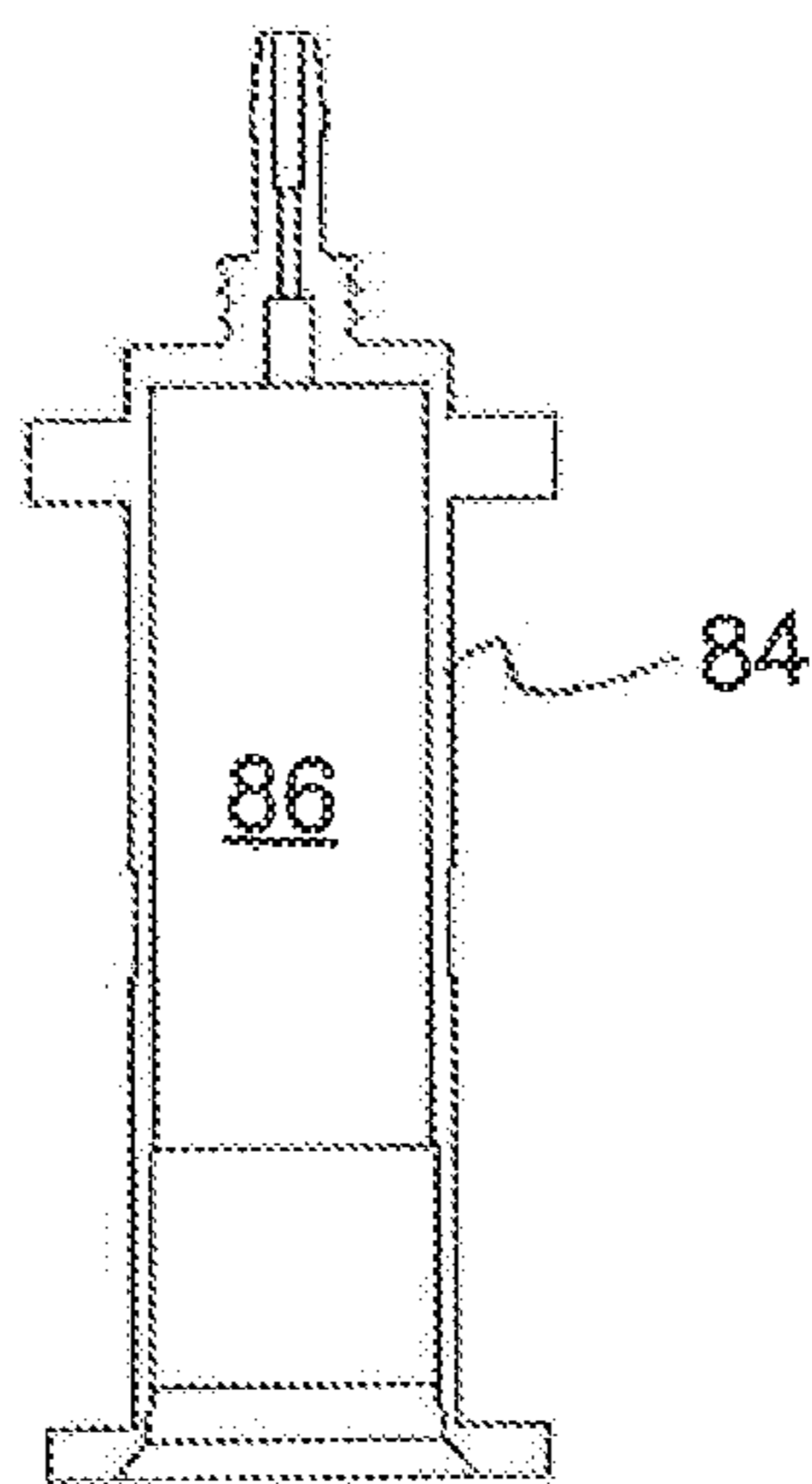
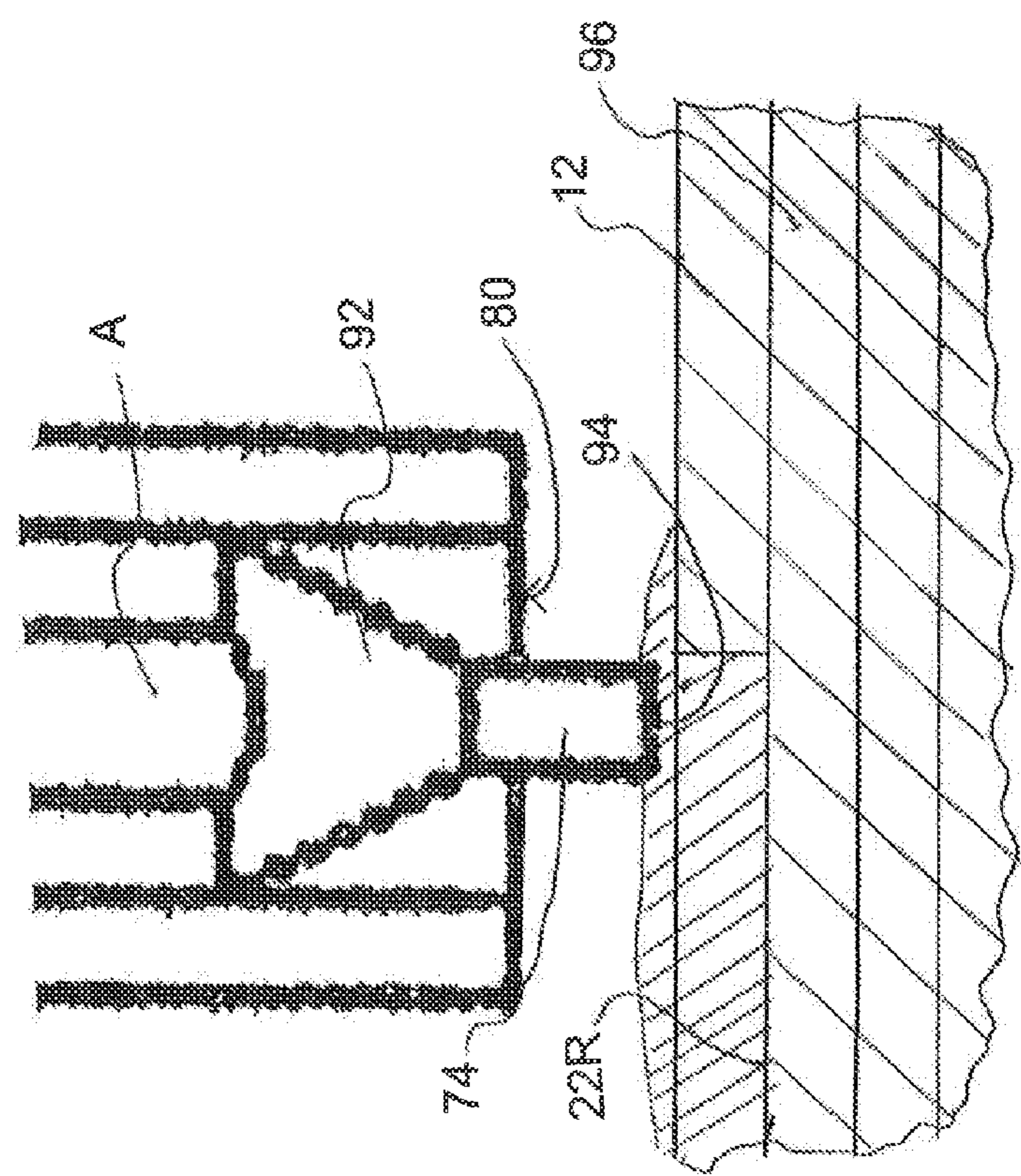
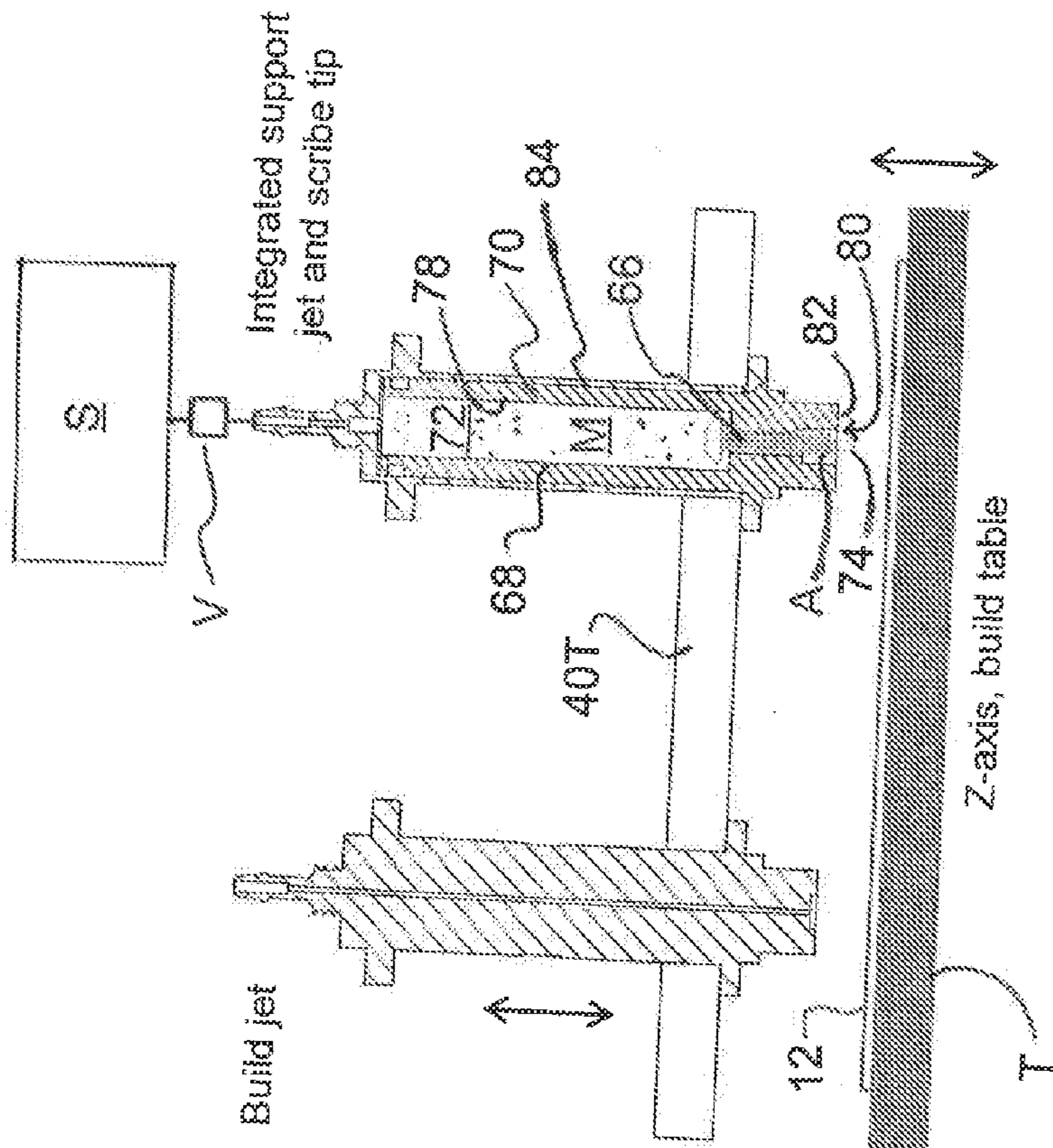

FIG. 5A



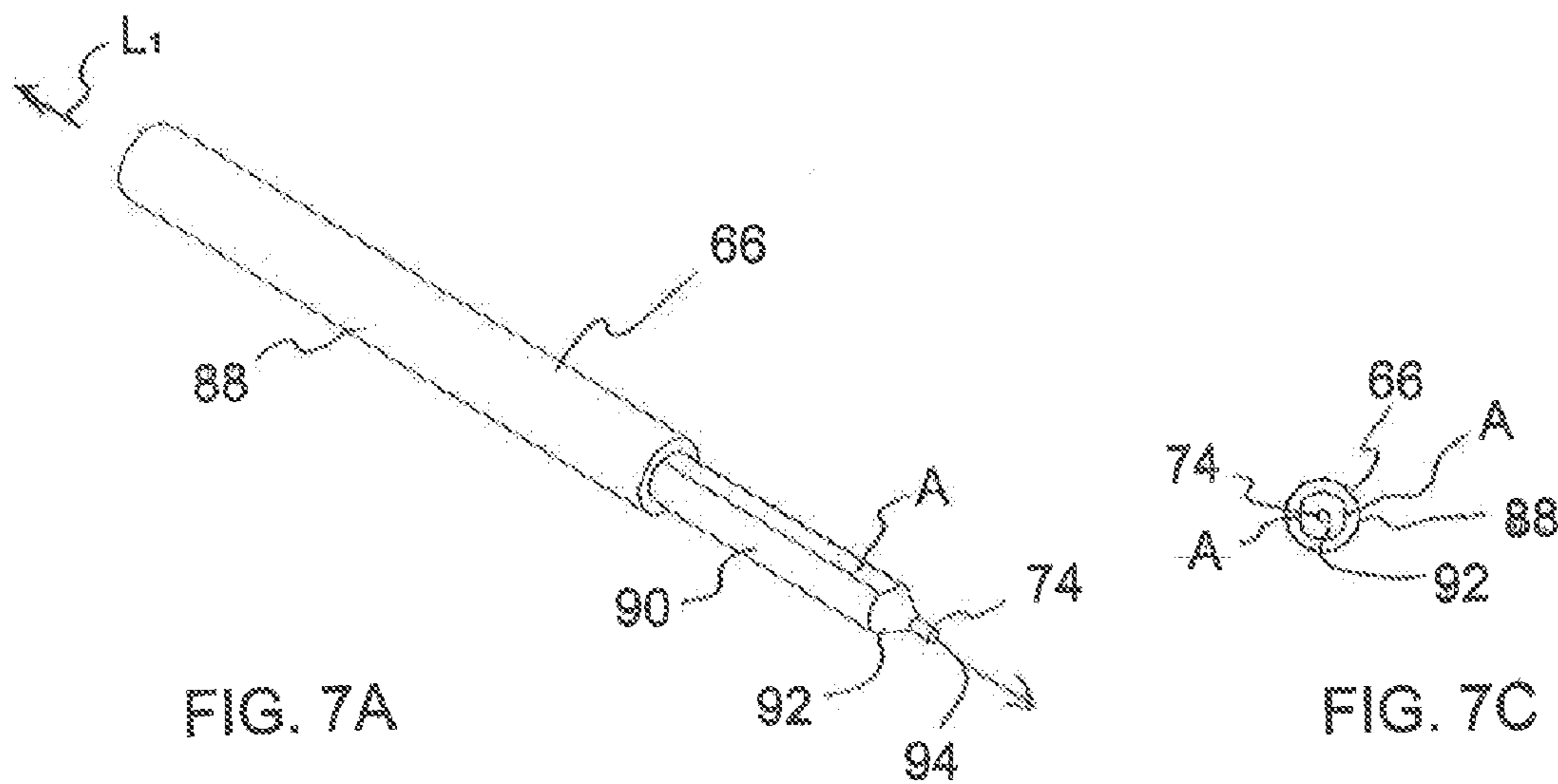

FIG. 7A

FIG. 7C

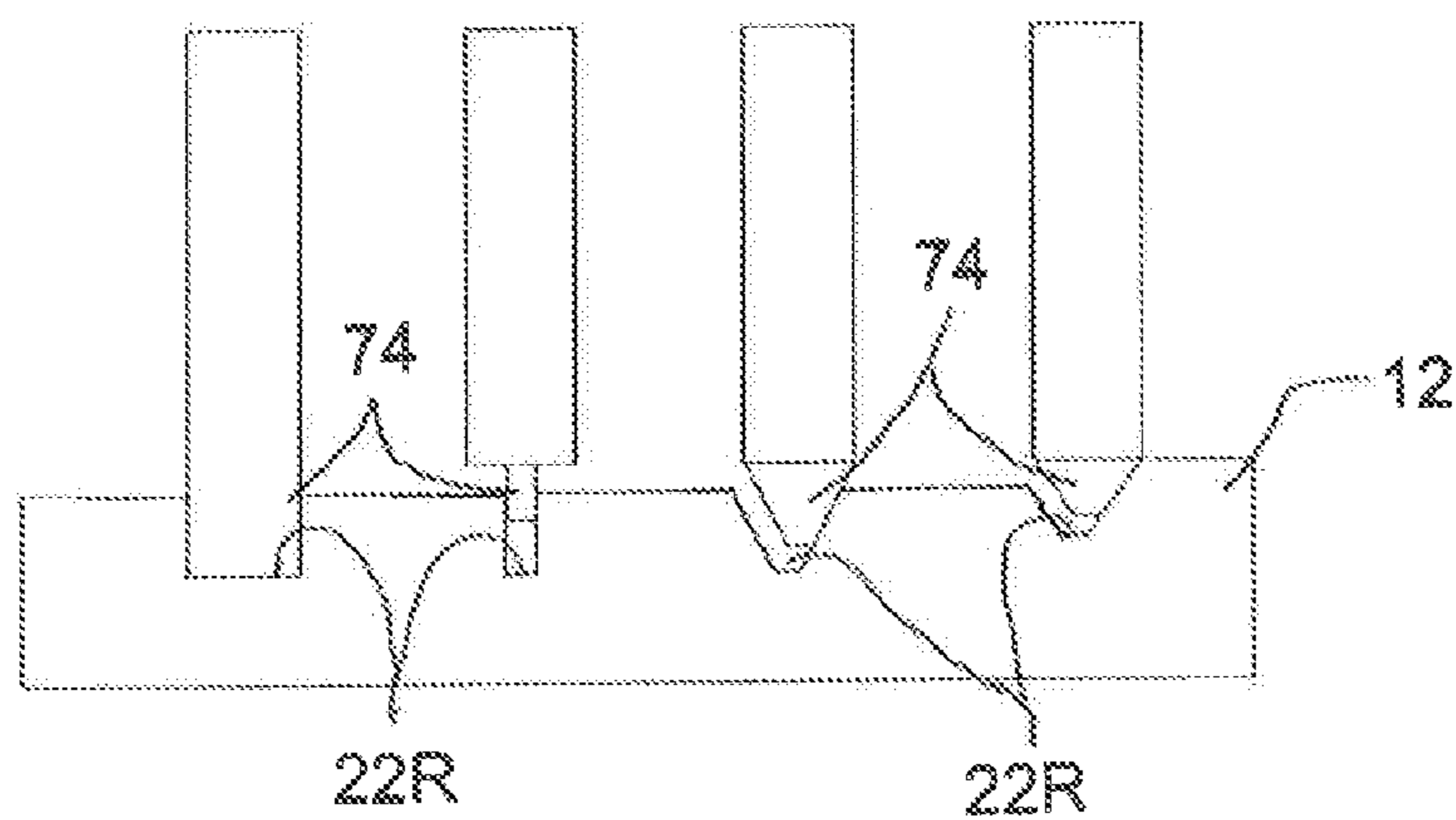
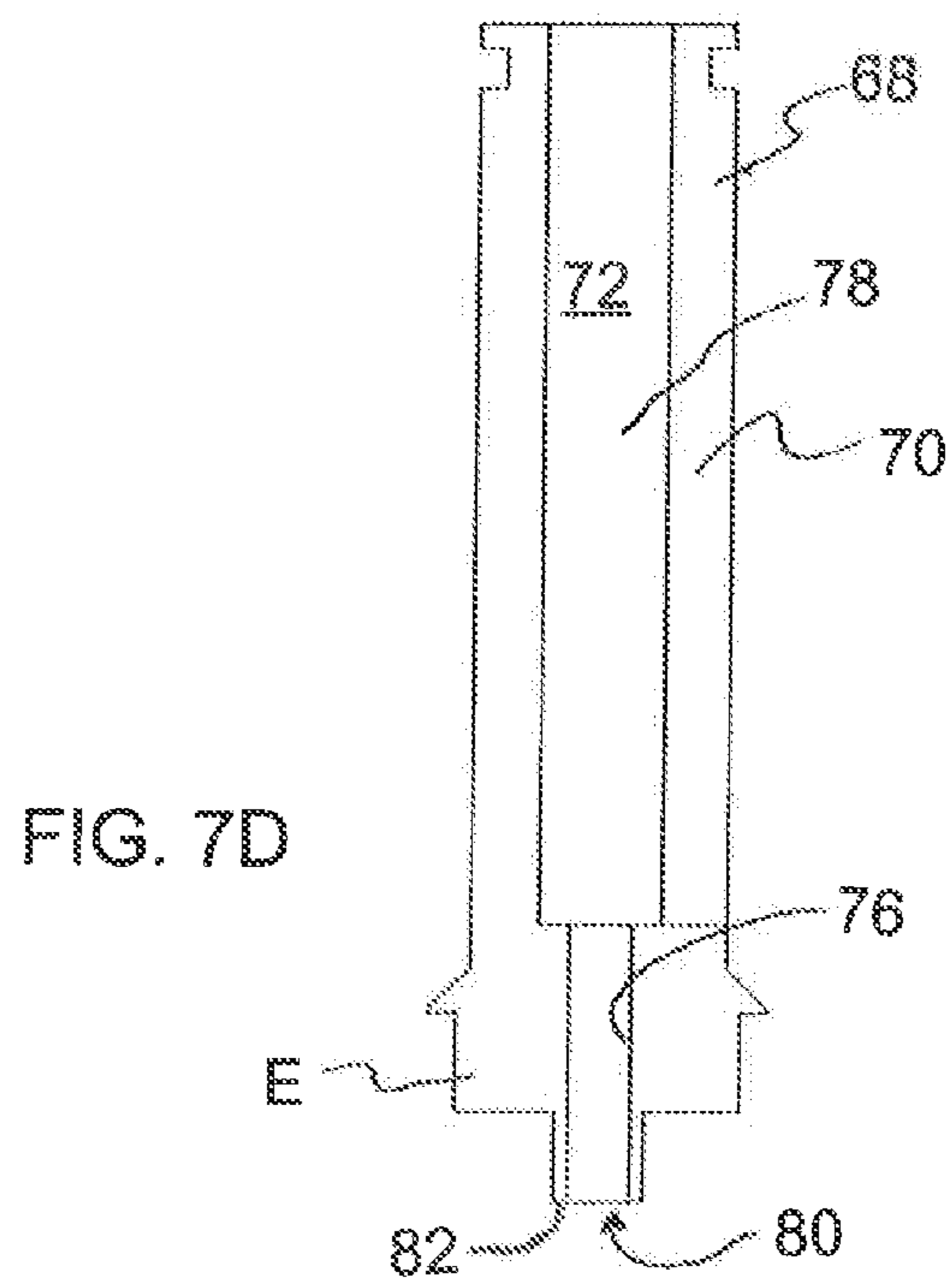
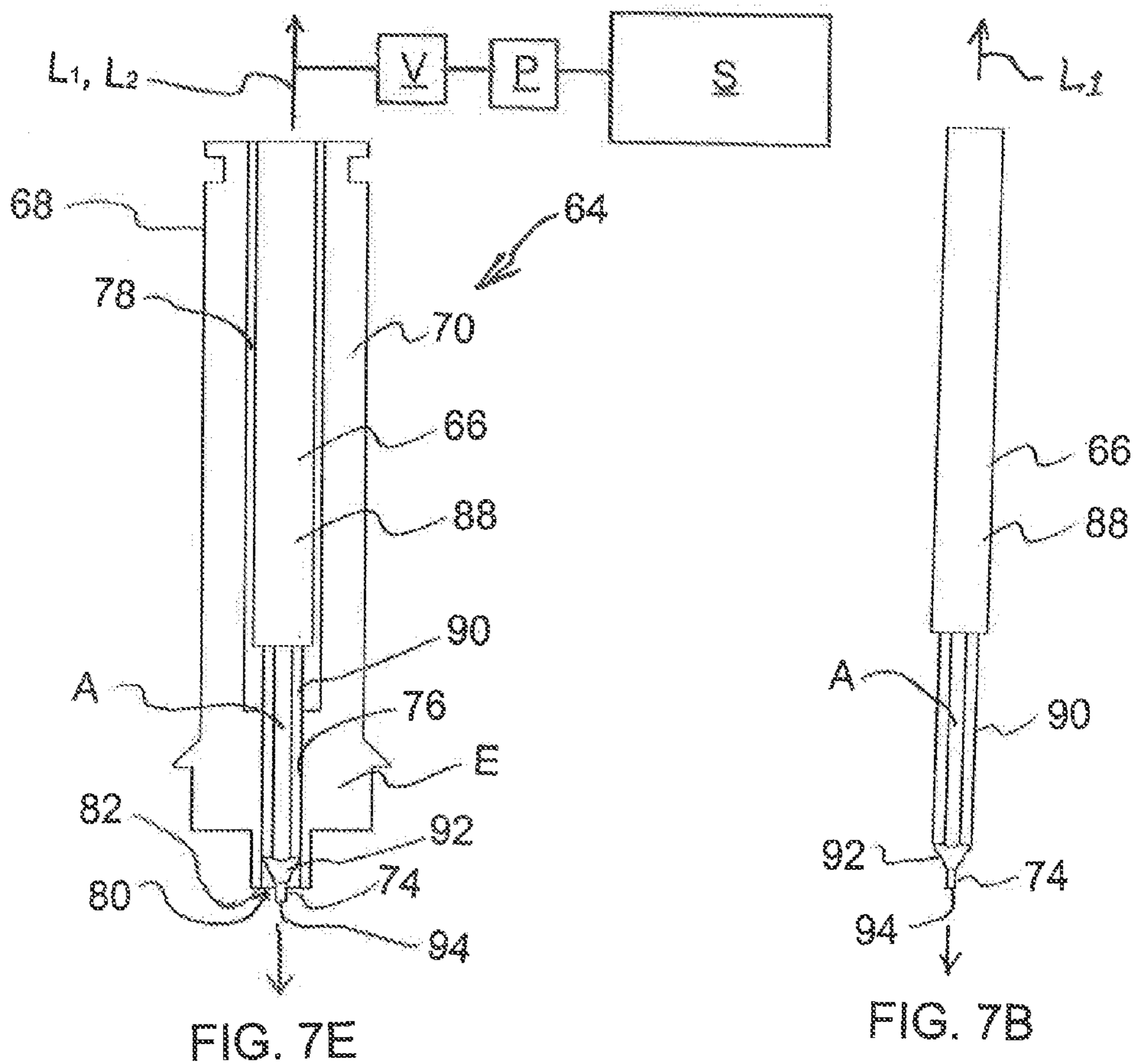

FIG. 8



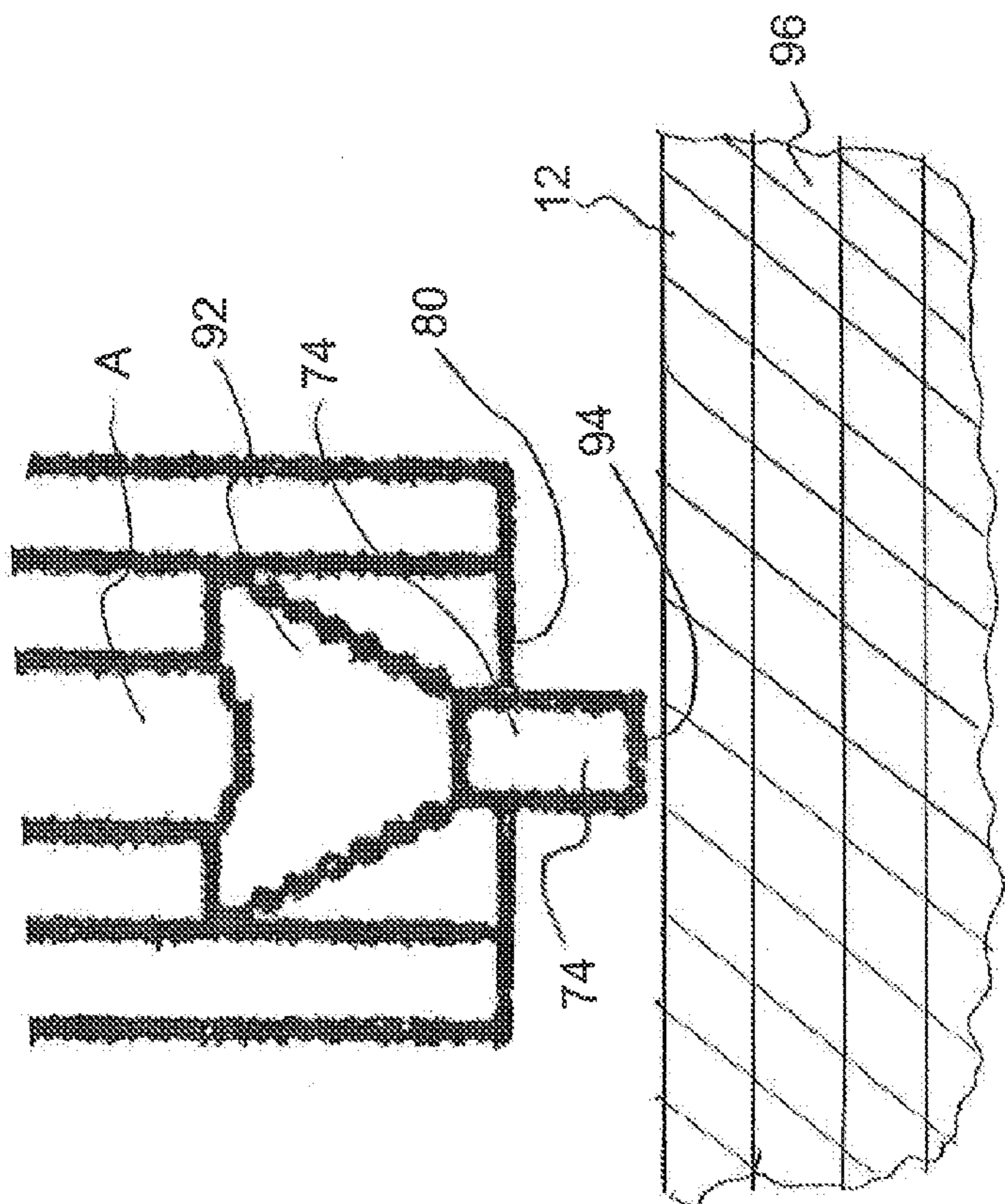

FIG. 9A

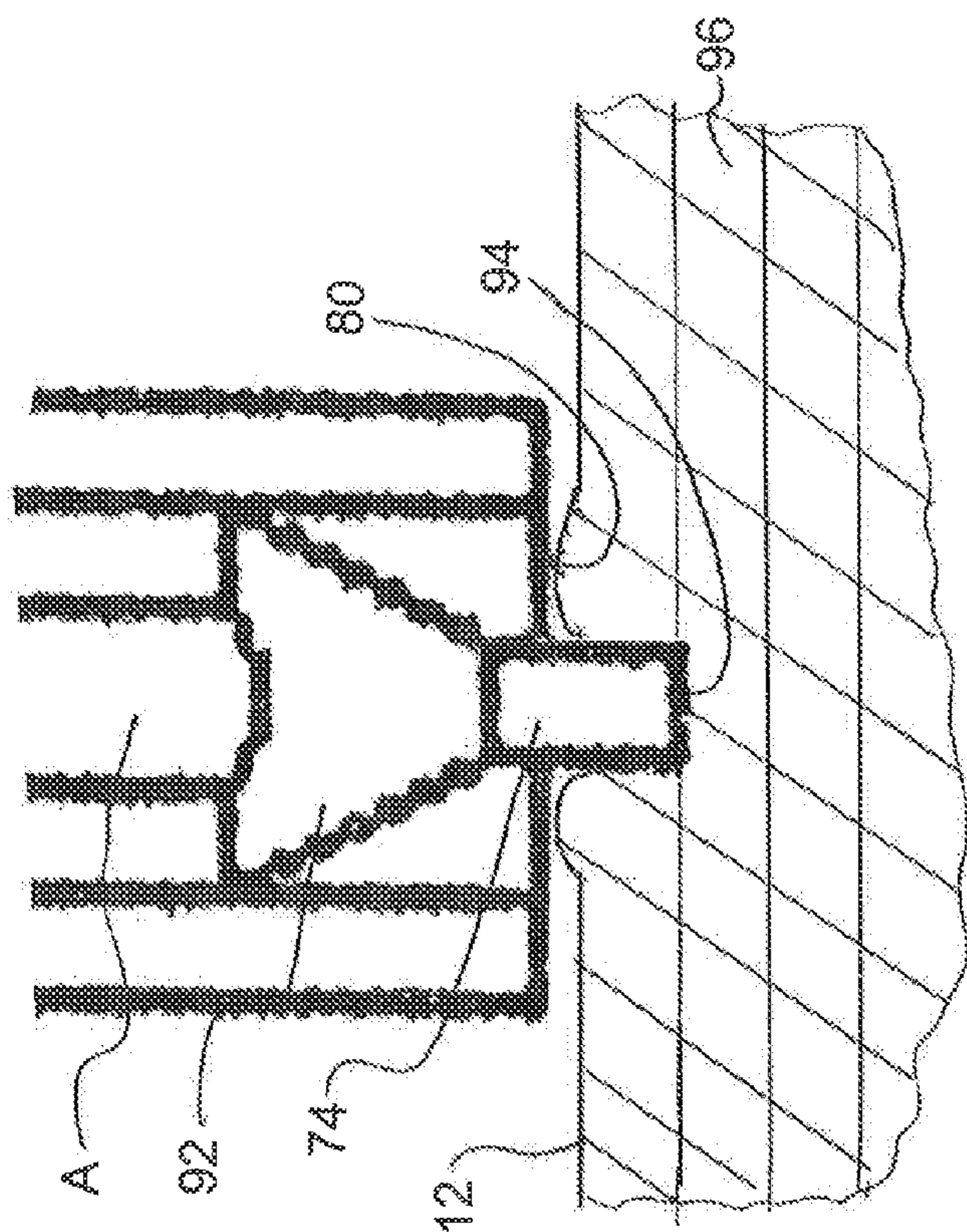

FIG. 9B



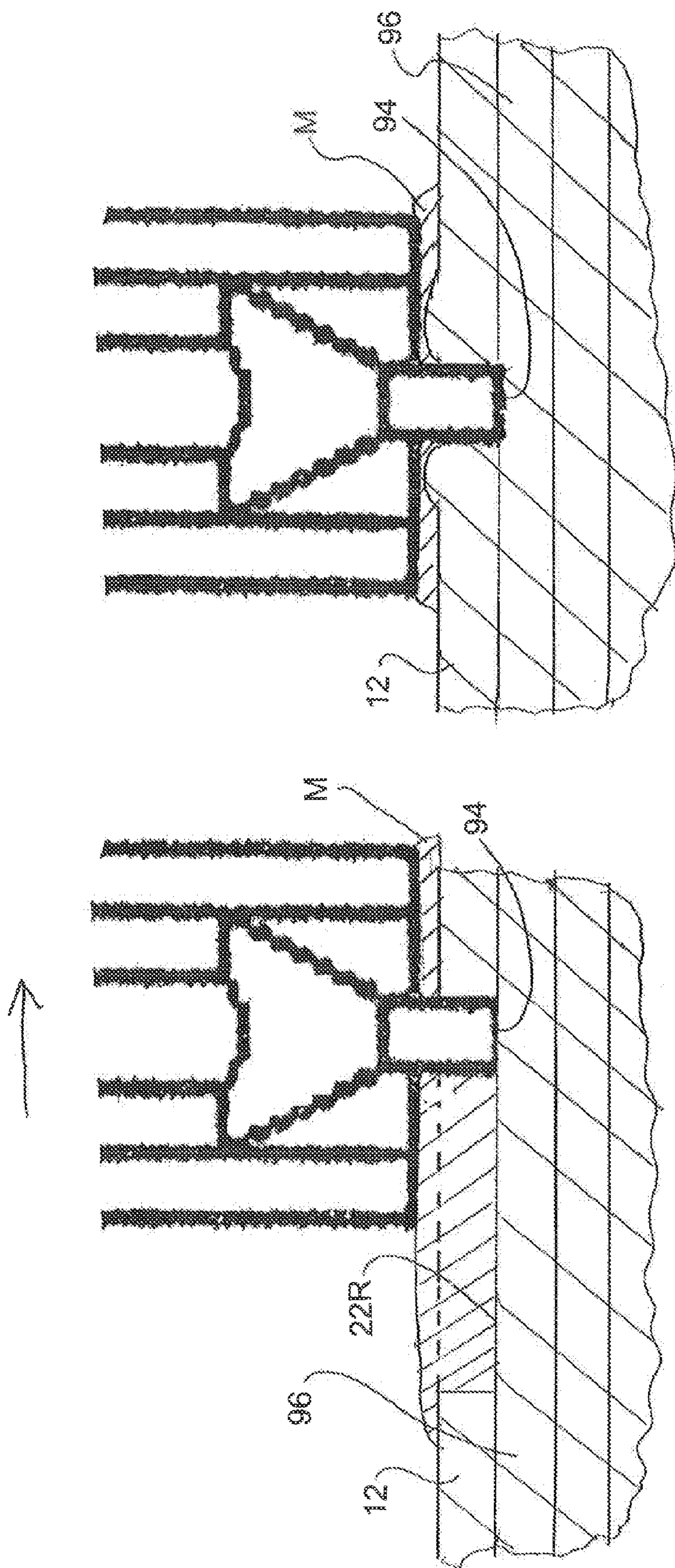

FIG. 9C

FIG. 9D

**METHOD AND APPARATUS FOR  
SIMULTANEOUSLY SCRIBING AND FILLING  
OF SCRIBED CHANNEL, TROUGH, TRENCH  
OR GROOVE**

FIELD OF THE INVENTION

[0001] The present invention relates to a system and a method for constructing three dimensional models and, in particular, to a method and system for fabricating three dimensional models by scribing a desired channel, trough, trench or groove in a layer currently being fabricated and simultaneously filling the scribed channel, trough, trench or groove with a desired filling material.

BACKGROUND OF THE INVENTION

[0002] Various methods and systems for construction of three dimensional models or objects have been developed for a number of applications, including the rapid fabrication of prototypes and the low volume fabrication of models and objects of varying degrees of complexity.

[0003] The need for rapid, low cost, low volume fabrication of models and parts has generally been met by various three dimensional (3D) modeling processes that employ layer by layer building processes. According to typical three dimensional modeling processes of the prior art, a model or a part is built up by the successive deposition of layers generally comprising a “model” material forming the final part to be manufactured and a sacrificial material that provides support for the model material during the building or fabrication process. Following completion of the fabrication or building process, the sacrificial material is subsequently removed thereby leaving the model material which forms the final part to be manufactured.

[0004] Typical examples of three dimensional modeling processes of the prior art include, for example, Householder '508, U.S. Pat. No. 4,247,508, which describes a modeling process that employs two substances, one a fill material and the other a mold material, that are deposited layer by layer to build an article. The two materials in each layer are not in contact with each other while the layer is being formed because Householder '508 uses a grid to separate the two materials as they are being deposited. After the materials in each layer are deposited, the grid is moved to the next layer so that the two materials may fill the space left by the removed grid and thereafter solidify in contact with each other in the same layer.

[0005] Helinski, U.S. Pat. No. 5,136,515, describes a method wherein a three dimensional model is produced layer by layer by jetting droplets of at least two solidifiable materials, one material forming the article and a second material forming a support for the article. The second material is subsequently removed by heating, cutting, melting, chemical reacting, and so on, to leave the desired article.

[0006] Penn, U.S. Pat. No. 5,260,009, describes a system and process for making three dimensional objects by dispensing layer upon layer of modeling material using an inkjet which is turned “on” or “off” according to a two dimensional data map of each layer of the object. The two dimensional data map is stored and relayed by a microprocessor and defines locations on a matrix at which printing is to occur in a manner such as is used in printing images using raster scan printing.

[0007] Sanders, Jr. et al., U.S. Pat. No. 5,506,607, describes a system for building three dimensional models by vector plotting layer-upon-layer applications of solidifiable substances. The layers are formed by expelling minuscule beads of the substances in a liquid or flowable phase onto a platform from one or more jets wherein the jets and platform are relatively movable in the X, Y and Z coordinate system and the beads are deposited along vectors during X-Y relative movement.

[0008] Sanders, Jr. et al., U.S. Pat. No. 5,740,051, describes a method and apparatus for producing a three dimensional model by forming a continuous plurality of parallel layers of modeling material by repeatedly producing a plurality of bead producing drops of the modeling material for deposition at desired locations, controlling the locations and timing of deposition to produce vectors in any and all directions required to produce an outer surface defining a wall of a layer with a desired surface finish, and adjusting the distance of the location of drop production to the location of drop deposition in preparation for the formation of a subsequent layer.

[0009] Penn et al., U.S. Pat. No. 6,175,422, describes a method and process for computer-controlled manufacture of three dimensional objects by dispensing a layer of a first insoluble material, such as a liquid, onto a platform at predetermined locations corresponding to a cross-section of the object, which then hardens. A second material, preferably water soluble, is then sprayed onto this layer to thereby encapsulate the hardened insoluble material. The uppermost surface of this encapsulant is planed, thus removing a portion of the encapsulant to expose the underlying insoluble material for a new pattern deposition. After the resulting planing residue is removed, another layer of liquid, insoluble material is dispensed onto the planed surface. The insoluble material can be of any color and may vary from layer to layer, and from location within a layer to location with a layer. These steps are repeated, until the desired three dimensional object, encapsulated in the soluble material, is completed. At this point, the object is either heated or immersed in solvent, thereby dissolving the soluble material and leaving the three dimensional object intact.

[0010] Other systems and methods of the prior are described, for example, in U.S. Patent Publication No. 2009/0252821 which relates to a method of fabricating a model by deposition of a model material and a sacrificial material in layers wherein the sacrificial material which defines the bounds of the model is deposited drop by drop and the model material is deposited at high speed by spraying, while U.S. Patent Publication No. 2010/0021638 additionally describes the use of a third material to construct the layers and U.S. Pat. No. 6,019,814—relates to the use of a nozzleless, ultrasonic device for the sequential deposition of the materials.

[0011] U.S. Patent Publication No. 2005/087897 relates to a variation of the basic method for constructing a model by deposition of successive layers of a model material comprising the model and shell material enclosing the model material wherein certain layers may be deposited as partial layers to reduce the volume of material to removed when each layer is planed and to permit the construction of more complex geometries in the layers.

[0012] U.S. Pat. No. 5,209,878 relates to the use of either thin partial layers of material or a material capable forming a meniscus in the edge regions between successive layers of different dimensions to reduce or eliminate “stairstep” voids created at the edges of layers having different dimensions.

**[0013]** U.S. Patent Publication No. 2002/0129485 describes a system which is an agglomeration of previously known systems for fabricating three dimensional objects which thereby provides a very flexible but complex system capable of achieving features of a wide variety of methods.

**[0014]** Other prior art systems employ methods somewhat analogous to those used to construct three dimensional objects as successive layers of different materials, but as adapted specifically and essentially to object molding processes. For example, U.S. Patent Publication No. 2004/0089980 describes a method for fabricating three dimensional models by deposition and machining of three or four successive thick layers, thereby concurrently forming a mold for the object and the object itself. The layers include a first additive (non-sacrificial) layer which is machined to define the bottom contour of a next layer, which is a second additive (non-sacrificial) layer. The second additive (non-sacrificial) layer is deposited on the first subtractive (sacrificial) layer and machined to define the upper contour of the second additive (non-sacrificial) layer, which is the top of the finished model, with a second subtractive (sacrificial) layer being deposited and machined, if desired. The subtractive (sacrificial) material is removed when all layers are completed, thereby leaving a model formed of the additive (non-sacrificial) material.

**[0015]** U.S. Pat. No. 7,003,864 describes a method that is generally similar to that described in U.S. Patent Publication No. 2004/0089980 in depositing and machining three layers which concurrently form a mold for an object and the object itself, including depositing and planing a base layer of support material, depositing and removing regions of a second layer to form a mold of the part, adding a construction material to the removed regions of the second layer, and planing or machining the support and construction materials of the second layer.

**[0016]** The methods and systems of the prior art, for fabricating three dimensional models and objects, however, each have a significant number of fundamental problems.

**[0017]** For example, certain systems, such as those described in U.S. Patent Publication No. 2002/0129485, U.S. Patent Publication No. 2004/0089980, and U.S. Pat. No. 7,003,864, fabricate objects or molds by machining the objects or molds from relatively thick layers of material. Such systems, however, require the removal of significant amounts of material by machining processes and tools that are capable of the desired precision and often require a variety of machining tools heads in order to obtain the desired contours in the objects or molds, so that such systems are typically slow and wasteful and requiring complex, expensive machining components or elements.

**[0018]** Other of the systems and methods of the prior art, such as those described in U.S. Pat. No. 4,247,508, U.S. Pat. No. 5,136,515, U.S. Pat. No. 5,260,009, U.S. Pat. No. 5,506,607, U.S. Pat. No. 5,740,051, U.S. Pat. No. 6,175,422, U.S. Patent Publication No. 2009/0252821, U.S. Patent Publication No. 2005087897, U.S. Pat. No. 5,209,878, and U.S. Patent Publication No. 2002/0129485, fabricate objects by the deposition and selective removal of thin layers of two or more materials, thus allowing the fabrication of more complex objects by relatively less complex or expensive systems. Such systems, however, require that at least one material be deposited on the layers, during the building process, by a drop-by-drop deposition process in order to define the surfaces of the object with the desired precision but this results in a relatively slow building processes.

**[0019]** The present invention provides a solution to many of the above as well as other related problems of the prior art.

#### SUMMARY OF THE INVENTION

**[0020]** Wherefore, it is an object of the present invention to overcome the above mentioned shortcomings and drawbacks associated with the prior art.

**[0021]** An object of the present invention is to deposit both the model material and the sacrificial material, at rapid deposition rates, so as to facilitate rapid production of the composite model. Preferably both the model material and the sacrificial material are deposited at roughly the same deposition rates.

**[0022]** A further object of the invention is to facilitate formation of one or more channels, troughs, trenches or grooves, in the currently being fabricated build layer of the composite model, and simultaneously fill each of the one or more of the concurrently formed channels, troughs, trenches or grooves with the sacrificial material and thereby form a continuous border or boundary between adjacent areas of the model material.

**[0023]** Yet another object of the present invention is to remove the model material, during formation of the one or more channels, troughs, trenches or grooves in the currently being fabricated layer of the composite model, at a relatively high rate of speed, to increase the fabrication rate of the composite model.

**[0024]** Still another object of the present invention is to streamline further the manufacturing process by combining the material removal step with the material filling step, into a single combined processing step, thereby further decreasing the time required to complete a layer and further improve the overall manufacturing efficiency of the 3D model to be fabricated.

**[0025]** Another object of the present invention is to utilize a single combined material removal/material filling step so that the dispensed filling material commences cooling immediately after being dispensed and deposited which, in turn, further decreases the required wait time, following depositing of the filling material, and subsequent planing of the layer being fabricated.

**[0026]** Yet another object of the present invention is to minimize the amount of filling material, which is dispensed and deposited within the formed channel(s), trough(s), trench(es) or groove(s) in the currently being fabricated build layer of the composite model so as to minimize the amount of fill material which is utilized, during the filling process and thereby avoid waste of fill material.

**[0027]** A further object of the present invention is to flood or otherwise provide excess filling material, in around and in the vicinity of the scribing head, to ensure that the formed channel(s), trough(s), trench(es) or groove(s) is adequately and completely filled with the filling material during the single combined material removal/material filling step.

**[0028]** A still further object of the present invention is to provide a combined material removal/material filling procedure which permits selective removal of a desired portion of the deposited material as well as selected deposition of the desired filling material so as to provide greater accuracy and improve the manufacturing.

**[0029]** The present invention further relates to a combined scribing/filling device for scribing a desired channel, trough, trench or groove in a layer currently being fabricated and simultaneously filling the scribed channel, trough, trench or

groove with a desired filling material, the combined scribing/filling device comprising: a scribing tool having a scribing tip which facilitates scribing of the desired channel, trough, trench or groove in the layer currently being fabricated; and a dispensing/shaping orifice for filling the scribed channel, trough, trench or groove with the filling material; wherein the scribing tip being located coincident with respect to the dispensing/shaping orifice to facilitate simultaneously scribing and filling of the channel, trough, trench or groove.

[0030] The present invention further relates to a method of fabricating a three dimensional model from a composite model formed by a plurality of layers with the composite model comprising at least one separation material encasing and enclosing a build material, the method comprising the steps of: (1) depositing a build layer of the build material onto a preceding layer; (2) removing a selected area of the build material from the deposited build layer and simultaneously depositing the separation material in any removed selected area of the build material; and (3) reducing the build layer to a desired final thickness for supporting a next subsequent build layer; and (B) repeatedly repeating steps (1) through (3) for each build layer until the composite model is completed.

#### BRIEF DESCRIPTION OF THE DRAWINGS

[0031] The invention will now be described, by way of example, with reference to the accompanying drawings in which:

[0032] FIG. 1 is an isometric view of an exemplary final model manufactured by the process of the present invention;

[0033] FIG. 1A is a diagrammatic flowchart depicting the various steps for fabricating the composite model according to the present invention;

[0034] FIG. 1B is a diagrammatic plan view of a deposited layer of the foundation material upon which the composite model is to be fabricated;

[0035] FIG. 1C is a diagrammatic side elevational view of FIG. 1B of the deposited foundation layer of FIG. 1B;

[0036] FIG. 1D is a diagrammatic side elevational view of FIG. 1B following planing of the deposited foundation layer;

[0037] FIG. 1E is a diagrammatic plan view of the deposited build layer with the maximum extent of subsequently vertically higher build layers of the composite model shown in dashed lines;

[0038] FIG. 1F is a diagrammatic top plan view of a current build layer, following formation of one or more removal area(s), channel(s) or region(s), while FIG. 1G is a diagrammatic cross sectional view of the build layer, along section line 1G-1G of FIG. 1F;

[0039] FIG. 1H is a diagrammatic top plan view of the current build layer, following deposition of the sacrificial material in the removal area(s), channel(s) or region(s), while FIG. 1I is a diagrammatic cross sectional view of the build layer, along section line 1I-1I of FIG. 1H;

[0040] FIG. 1J is a diagrammatic top view of the current build layer, following planing and cleaning of the build layer, while FIG. 1K is a diagrammatic cross sectional view of the build layer, along section line 1K-1K of FIG. 1H;

[0041] FIG. 1L is a diagrammatic side elevational view showing a plurality of build layers for forming the composite model according to the present invention;

[0042] FIG. 2A is an isometric view of an exemplary final model having undercut and void features with certain build layers of interest depicted;

[0043] FIG. 2B is a diagrammatic top view of the bottom most build layer for forming a void;

[0044] FIG. 2C is a diagrammatic top view of the build layer in the layer immediately above the void;

[0045] FIG. 2D is a diagrammatic top view of a current build layer showing a void through the composite model;

[0046] FIG. 2E is a diagrammatic top view of the penultimate build layer of the composite model;

[0047] FIG. 2F is a diagrammatic cross sectional view of the composite model taken along section line 2F-2F of FIG. 2A;

[0048] FIG. 2G is a diagrammatic cross sectional view of the composite model, taken along the section line 2F-2F of FIG. 2A, following removal of the extraneous model material;

[0049] FIG. 2H is a diagrammatic cross sectional view of the composite model, taken along section line 2F-2F of FIG. 2A, following removal of the sacrificial material;

[0050] FIG. 3A is a diagrammatic top plan view of a build layer of the composite model showing a different technique for a void;

[0051] FIG. 3B is a diagrammatic top plan of a build layer of the composite model with intersecting wall segments which form exterior reentrant angles and interior reentrant angles;

[0052] FIG. 3C is an enlarged, diagrammatic top plan view of area A of FIG. 3B showing the manufacturing problem associated with an interior reentrant angle;

[0053] FIG. 3D is an enlarged, diagrammatic top plan view of area A of FIG. 3B showing deposition of the reentrant (sacrificial) material, along the interior region of the interior reentrant angle, prior to deposition of the build layer;

[0054] FIGS. 4A-4C are diagrammatic representations of a system for fabrication of the three dimensional composite model according to the present invention;

[0055] FIG. 5A is a diagrammatic cross sectional view of a deposition head support according to the present invention;

[0056] FIG. 5B is a diagrammatic cross sectional view of a simple combined scribing/filling device, according to the present invention;

[0057] FIG. 5C is a diagrammatic cross sectional view of the combined scribing/filling device supported by deposition head support;

[0058] FIG. 6 is a diagrammatic cross sectional view showing the combined scribing/filling device and the deposition head support, according to the present invention, being supported by a conventional build table;

[0059] FIG. 7A is a diagrammatic perspective view of the scribing tool according to the present invention;

[0060] FIG. 7B is a diagrammatic side elevational view of the scribing tool of FIG. 7A;

[0061] FIG. 7C is a diagrammatic front elevational view of the scribing tool of FIG. 7A;

[0062] FIG. 7D is a diagrammatic cross sectional view of a high viscosity rapid deposition head;

[0063] FIG. 7E is a diagrammatic cross sectional view of the combined scribing/filling device;

[0064] FIG. 8 is a diagrammatic cross sectional view showing a variety of scribing tip profiles for forming a desired channel, trough, trench or groove, in the layer currently being fabricated, with a desired profile;

[0065] FIG. 9A is a diagrammatic cross sectional view showing the scribing tip, of the combined scribing/filling

device, prior to the scribing tip being forced into a top surface of the layer currently being fabricated;

[0066] FIG. 9B is a diagrammatic cross sectional view showing the scribing tip immediately after being forced into a top surface of the layer currently being fabricated;

[0067] FIG. 9C is a diagrammatic cross sectional view showing the dispensing of the high viscosity material, toward the scribing tip, immediately after the scribing tip is forced into a top surface of the layer currently being fabricated but before movement of the scribing tip relative to the layer currently being manufactured;

[0068] FIG. 9D is a diagrammatic cross sectional view showing partial formation of channel, trough, trench or groove in the layer currently being fabricated with the high viscosity material completely filling the channel, trough, trench or groove; and

[0069] FIG. 9E is a diagrammatic cross sectional view showing completion of channel, trough, trench or groove, after the scribing tip is retracted from the layer currently being fabricated and the high viscosity material fills the void left by retraction or withdrawal of the scribing tip.

#### DETAILED DESCRIPTION OF THE INVENTION

##### A. Introduction and Exemplary Fabrication of a Model

[0070] As will be described in detail in the following, the present invention is directed to a method and a system for fabricating three dimensional models by the fabrication of a composite model formed of successive layers of materials, with each successive layer of material typically comprising both a build material, generally comprising the model material, and a support material, generally comprising a sacrificial material. The separation material is typically deposited so as to form a boundary which completely surrounds and/or encases the build material and, following at least one removal process, allows the final model to separate from the support structure.

[0071] As note above, it is to be appreciated that, according to the present invention, each layer of the composite model is typically formed from the build (e.g., model) material, the separation (e.g., sacrificial) material or a combination of both materials while one or more foundation layers and one or more termination layers are typically formed from only one material, e.g., the sacrificial material or possibly the model material. In the intermediate layers which comprise both the build material and the separation material, the current layer of the composite model is initially formed by the deposition of a layer of the build material, for example, the model material, extending over an area greater than the maximum length and width dimensions of any subsequent layer of the composite model and, thereafter, one or more selected areas of the build material, typically in the form of a “channel”, a “trough”, a “trench” or a “groove” extending along vertical surface or surfaces of the model area or areas defining either a top or a bottom surface of a void in the composite model, are removed from the build material in that layer, by a precision machining process, to a depth extending normal from the top of the current layer of the build material to the top of the immediately adjacent preceding layer. Typical dimensions for the channel, the trough, the trench or the groove are a depth of between 0.00025 and 0.005 thousands of an inch or so and a width of between 0.00025 and 0.005 thousands of an inch or so.

[0072] The area or areas from which the build material is removed by the removal process are then subsequently filled with the filling or separation material, for example, a sacrificial material, so as to completely fill and enclose the removed area or areas with the separation material and finally the current layer is then planed to the desired surface thickness. Following planing of the surface, the planed layer is then cleaned or vacuumed to remove dust and debris and thereby complete fabrication of the currently layer so that the partially completed composite model is thus prepared for fabrication of the next subsequent build layer of the model. This process is then repeated numerous times until fabrication of the three dimensional composite model is eventually completed.

[0073] As noted above, this method is then repeated, layer by layer, numerous times with each layer being formed of the build material, the separation material, or both the build and the separation materials, as required depending upon the specific details or features of the composite model in each layer being fabricated. It is to be appreciated that either, or both, the build material and the separation material may be used to construct or fabricate support regions or areas for subsequent layers of the separation and/or the build materials.

[0074] Referring now to FIGS. 1-1L, the process of fabricating, according to one embodiment of the present invention, the exemplary final model 10, shown in FIG. 1, will now be discussed. In the following discussion, the build material will be generally referred to as the model material 14 while the separation material will be generally referred to as the sacrificial material 16. It is to be appreciated, however, depending upon the particular application, the build material may be the sacrificial material 16 while the separation material may be the model material 14.

[0075] In FIG. 1, a final model 10, formed from a composite model 10C (see FIG. 2A) which comprises numerous layers 12 of the model material 14 and/or the sacrificial material 16, is generally shown. Each layer of the composite model 10C is typically includes both the model material 14 and the sacrificial material 16 which are deposited in selected areas of the build layer with one material being deposited before the other.

[0076] As shown in FIGS. 1 and 1B, the exemplary model 10 comprises a plurality of layers 12 with the layer of the present discussion comprising the bottom most layer 12F of the composite model 10C as constructed or fabricated according to the method of the present invention which, as described in detail below, generally includes initial steps 18A and 18B followed by repetitive step 18C, which comprises a sequence of steps 18D-18G, and may conclude with a termination step 18H, although this may not be necessary, and at least one removal step 18I and possibly a second removal step 18J.

[0077] As illustrated in FIG. 1B, the fabrication of the composite model 10C begins with a step 18A in which one or more foundation layers 12F are first deposited on a desired model support surface or table T, such as a vertically movable table, where the one or more foundation layer(s) 12F are typically fabricated solely from the sacrificial material 16, for example, and such layers thereby forming the foundation for a boundary so that, following completion of the composite model 10C as described further hereinafter, the boundary totally surrounds and encapsulates the composite model 10. As will be described, the boundary totally encases the final model 10 and protects the model material 14, from which the final model 10 will eventually be fabricated, from the subsequent processes by which any extraneous model material 14

is eventually removed from the composite model 10C to thereby result in the final model.

[0078] The number of foundation layers 12F, required for any given composite model 10C, can vary from one to numerous layers and may be determined, for example, by the properties of the sacrificial material 16, the thickness of the initial foundation layer or layers 12F, the design of the final model 10 and, in particular, the lower regions of the final model 10, the accuracy of the model support surface or table T, etc. As illustrated in FIG. 1B, the area covered by the foundation layer or foundation layers 12F must, at a minimum, exceed the maximum length and the maximum width dimensions of the final model 10 for each one of the subsequent vertically higher build layers 12M of the composite model 10C by an amount equal to or greater than the minimum width and/or minimum length of the areas of the model material 14 that, as discussed below, are removed from subsequent, higher layers 12 of the composite model 10C during construction or fabrication of those subsequent build layer 12M. The extent (i.e., the maximum width and length dimensions) of the foundation layer or layers 12F thereby ensure that each subsequent build layer 12M, of the composite model 10C, are fully vertically supported by the foundation layer or layers 12F formed on the model support surface or the table T. As generally indicated in FIG. 1C, the thickness of each foundation layer 12F, as initially deposited on the model support surface, must also exceed the intended final thickness of that the foundation layer 12F.

[0079] Following sufficient solidification of each deposited foundation layer 12F, the just deposited foundation layer 12F is typically planed to the intended final thickness of the foundation layer 12F and sufficiently cleaned, e.g., by blowing or vacuuming for example, during step 18B, thereby to provide a smooth, level surface for deposit of the subsequent, next foundation layer for the composite model 10C, as illustrated in FIG. 1D. Steps 18A and 18B are repeatedly repeated and once a sufficient amount of foundation layers 12F are deposited upon the vertically movable table T, e.g., typically once the entire surface area of the top most foundation layer 12F was at least partially planed thereby indicating that the top most foundation layer 12F perfectly is level with respect to the build apparatus, then construction of the actual composite model 10C can commence.

[0080] The composite model construction begins during build step 18C which includes the repetition of steps 18D through 18G. During step 18D, as illustrated in FIG. 1E, a first build layer 12M of the model material 14 is deposited upon the top most foundation layer 12F and this layer of the model material 14 typically forms a boundary or a transition layer between the foundation layers 12F and the composite model 10C. This first build layer 12M of the model material 14 (as generally shown in FIG. 1E) typically does not include any removal area(s), channel(s) or region(s) 22R therein and, once deposited, the first build layer 12M of the model material 14 is then planed and cleaned, as discussed herein, during build layer planing/cleaning step 18G.

[0081] During step 18D, a second build layer 12M of model material 14, as also illustrated in FIG. 1E, is deposited on top of the first build layer 12M of the model material 14. The dimensions of the layer of the deposited model material 14 for the first, the second and for each subsequent build layer 12M of the model material 14 of the composite model 10C, must again extend over an area that is again equal to or greater than the maximum extent, i.e., the maximum width and length

dimensions, of the final model 10 for all subsequent, vertically higher build layers 12M of the composite model 10C by an amount equal to or greater than the minimum width or the minimum length of the areas of the model material 14 that are removed from each subsequent higher build layer(s) of the composite model 10C during construction or fabrication of those subsequent layers. The extent (i.e., the maximum width and length dimensions) of each build layer 12M thereby ensures that all subsequent layers of the composite model 10C are completely supported vertically by the vertically lower build layers 12M. Also, the model material 14 is again deposited at a thickness equal to or preferably somewhat greater than the intended final thickness of the build layer 12M to ensure that each build layer 12M can be subsequently planed to the intended final thickness and subsequently cleaned. FIG. 1E illustrates the maximum extent, in dashed lines, of the current build layer 12M for the final model 10 shown in FIG. 1.

[0082] FIG. 1F is a diagrammatic top view of the current build layer 12M, following completion of removal step 18E, while FIG. 1G is a diagrammatic cross sectional view of the build layer 12M along section line 1G-1G of FIG. 1F. Removal step 18E generally comprises the removal of a minor portion the deposited model material 14, in one or more selected the removal area(s), channel(s) or region(s) 22R that extend along any surface 24 or surfaces 24 of the composite model 10C in or on that the build layer 12M, by a precision routing, drilling, boring or some other machining process. During this material removal process, one or more selected areas of the deposited model material 14, in the current build layer 12M, are removed to a depth extending from the top of the current build layer 12M precisely to the beginning of the immediately adjacent preceding build layer 12M, but generally without removing any material from the immediately adjacent preceding build layer 12M. Accordingly the routing, drilling, boring or other machine tool must have a generally flat or planar leading surface so as not to router, drill, bore or machine into the immediately adjacent preceding build layer 12M. FIGS. 1F-1G generally illustrate completion of the removal step 18E, of the method of the present invention, once the selected areas of the model material 14 are removed. It is to be borne in mind that the removal of a portion of the model material 14, from the removal area(s), channel(s) or region(s) 22R and the radially outwardly facing surface of the removal area(s), channel(s) or region(s) 22R, partially defines the exterior surface of the boundary while the radially inwardly facing of the removal area(s), channel(s) or region(s) 22R partially define the exterior surface of the composite model 10C of the build layer 12M generally being constructed 10.

[0083] The removal area(s), channel(s) or region(s) 22R are typically of the form of one or more “recess(es)”, a “trench(es)” or a “groove(s)” extending along the surface 24 or surfaces 24 of the composite model 10 in the current build layer 12M and are of a desired width or thickness which is equal to the desired width or thickness of the boundary in that region and layer of the composite model 10. It must be noted, however, that the removal area(s), channel(s) or region(s) 22R may comprise a larger region, such as a region defining either a top horizontal surface or the bottom horizontal surface of a void or space in the preceding build layer 12M or in the next higher build layer 12M of the composite model 10.

[0084] FIG. 1H is a diagrammatic top view of the current build layer 12M, following completion of deposition step

**18F**, while FIG. 1I a side sectional side view of the current build layer **12M**, along section line 1I-1I of FIG. 1H. During step **18F**, the sacrificial material **16** is deposited in the removal area(s), channel(s) or region(s) **22R** of that build layer **12M**, with such deposition typically occurs by a rapid deposition process such as spraying. The deposition of the sacrificial material **16** in the removal area(s), channel(s) or region(s) **22R** thereby creates one or more sacrificial material “inlay” areas **22S** which are filled with the sacrificial material **16** and thereby form part of the encapsulating boundary of the sacrificial material **16** which encloses the outwardly facing surfaces **24** of the composite model **10** in that the build layer **12M**. It is to be appreciated that the sacrificial material **16**, when deposited over and filling the removal area(s), channel(s) or region(s) **22R** from where the model material **14** was removed, must be still sufficiently molten so as to flow into and completely fill the entire space of the removal area(s), channel(s) or region(s) **22R**. It is to be noted that the deposition or filling of the sacrificial material **16** extends downward from the current build layer **12M** to the top surface of the immediately preceding adjacent layer **12P** and has a thickness which is at least equal to, or more preferably greater than, the intended final thickness of the current build layer **12M**. It will also be noted that one or more regions of the sacrificial material **16** on the current build layer **12M** may, in turn, be enclosed within a complete or partial boundary or mass of extraneous model material **14E** that, while not comprising a part of the intended final model **10**, was not removed from the current layer **12**.

**[0085]** According to the present invention, the surfaces **24** of the composite model **10C** along which removal areas **22R** are located include each surface **24** of the composite model **10** that is present in the mostly recently deposited current build layer **12M**, any surface **24** of the composite model **10** of a next higher build layer **12M** that would be adjacent the current build layer **12M**, and any surface **24** of the composite model **10** on the preceding layer **12** that is adjacent to the current build layer **12M**.

**[0086]** FIG. 1J is a diagrammatic top view of the current build layer **12M**, following completion step **18G** of the method of the present invention, while FIG. 1K is a diagrammatic cross sectional view of the build layer **12M**, along section line 1K-1K of FIG. 1F. During step **18G**, the current build layer **12M**, including the deposited sacrificial material **16** forming the part of the encapsulating boundary enclosing the surfaces **24** of the composite model **10** on the current layer, as well as the model material **14** are all planed to the desired final thickness of the current build layer **12M** and then suitably cleaned by either a blowing, vacuuming or some other dust and debris removal process, thereby completing formation of that build layer **12M**. The completion of steps **18D** to **18G** thereby results in formation of a top most build layer **12M** which now forms a smooth, level support surface for deposition of the next subsequent build layer of the composite model **10** to be fabricated.

**[0087]** Process step **18C**, which includes process steps **18D-18G**, is then repeatedly repeated, numerous time as necessary or required, until the entire composite model **10C** is finally completed, with each layer **12** generally comprising the model material **14** or the sacrificial material **16**, or a combination of both materials, as necessary, so as to result in completion of the composite model **10** and the encapsulating boundary in each build layer **12M**.

**[0088]** Following construction of the final or top most build layer **12M** that includes at least one part of the composite model **10**, during step **18H**, one or more terminal layer or layers **12T**, which are fabricated solely from the sacrificial material **16**, are then deposited on top of the final model layer **12M**, as diagrammatically illustrated in FIG. 1M. As with the case of the foundation layers **12F**, the terminal layers **12T** generally completely formation of the top surface of the encapsulating boundary which completes formation of the top most horizontal surface that completes encapsulation of the composite model **10C** so as to support the composite model **10C** and thereafter protect the model material **14** of the composite model **10C** during removal of any extraneous model material **14** from the composite model **10C**, as discussed below in further detail. The number of terminal layers **12T**, required for any given composite model **10C**, can vary and again may be determined, for example, by the properties of the sacrificial material **16**, the thickness of the terminal layer or layers **12T**, the design of the composite model **10C** and, in particular, the upper regions of the composite model **10C**, etc.

**[0089]** The terminal boundary layer or layers **12T**, if applied, generally covers all areas of the composite model **10C** that remain exposed upon completion of the last fabricated layer **12M** that includes at least one part of the composite model **10C** and again must be deposited to a sufficient height that at least meets, and more preferably exceeds, the intended final thickness of that layer **12T**. If more than one terminal layer **12T** is required, any sacrificial material **16** for each terminal layer **12T** preceding the final terminal layer **12T** and that exceeds the intended final thickness of the terminal layer **12T** is removed after solidification of the sacrificial material **16**, for example, by a planing process so as to provide a smooth, level surface upon which the next terminal layer **12T** is deposited.

**[0090]** Lastly, and upon completion of the composite model **10C**, the sacrificial material **16** as well as all extraneous model material **14E**, not forming a part of the final model **10**, are selectively removed during one or more removal steps, illustrated by removal step **18I**. During removal step **18I**, the extraneous model material **14E** is first removed and then, during a separate second removal step **18J**, the encapsulating boundary, comprising the sacrificial material, is removed. The process or methods for individually removing the extraneous model material **14** and the sacrificial material **16** may employ solvents for dissolving one of the materials, heating of the composite model **10C** to different temperatures for melting one of the materials, and so on and any combination thereof which are well known in the art. Alternatively, both the extraneous model material **14E** and the sacrificial material **16** may be removed from the composite model **10C** during a single removal process, during removal step **18I**.

**[0091]** Considering certain aspects of the above described basic method of the present invention in further detail, and according to the present invention, the model material **14** may be deposited as a solid or a liquid, but must have characteristics which allow the model material **14** to entirely fill the area of the current layer **12** being fabricated to a uniform thickness, density and/or height that at least meets and more preferably exceeds the intended final thickness of that layer **12** following solidification of the model material **14** into its solid state and, if deposited as a liquid, the model material **14** must sufficiently cure, freeze or solidify into a solid state very rapidly following deposition. The model material **14** may be

deposited by a selective or non-selective processes wherein possibly non-selective processes include roller transfer, a spray or an extrusion process which typically deposits the model material **14** at a much higher deposition rate than selective techniques such a jetting individual drops of the model material **14**. As described, it is necessary that the area covered by the model material **14** include, at a minimum, the entire area that is to be occupied by the model material **14** in the current model material layer **12M** and by all subsequent build layers **12M** of the composite model **10C**. It is also necessary that each build layer **12M** includes sufficient excess area at the perimeter of the current build layer **12M** so as to ensure that a sufficiently wide removal area **22R** can be excavated or removed from the build material **12** around the model surfaces **24** and, thereafter, subsequently accommodate the sacrificial material inlays areas **22S** that form the encapsulating boundary around the composite model **10C**. The model material **14** is deposited over an area that, at a minimum, is equal to, or more preferably exceeds, the extent of all subsequent build layers **12M**, even when this area exceeds the area required by the current build layer **12M**. This extended coverage ensures that there is a surface upon which subsequent layers, that include larger portions of the composite model **10C** than those in the current layer **12**, can be deposited and adequately supported.

[0092] The sacrificial material **16** may likewise may be deposited into removal areas **22R** as a solid or a liquid. If the sacrificial material **16** is deposited as a liquid or a semi-solid, the sacrificial material **16** must sufficiently cure, freeze or solidify into its solid state quite rapidly following deposition, and must have characteristics allowing the sacrificial material **16** to entirely and completely fill all of the interior space within the area(s), channel(s) or region(s) **22R** created in the model material **14** to a generally uniform thickness and density without leaving any gap(s), crack(s), opening(s) and/or void(s) within any portion of the removal area(s), channel(s) or region(s) **22R** that could be permeated during the subsequent removal of the extraneous model material. The sacrificial material **16** may be deposited by a selective or a non-selective process wherein such non-selective processes include a roller transfer, a spray or an extrusion process and typically deposits the model material **14** at a much higher deposition rate than selective techniques such a jetting individual drops of the model material **14**. Other means or mechanisms, such as a pressure plate or roller, may be employed to achieve the desired final filling of the sacrificial material **16** into the areas to be occupied by the sacrificial material **16**. Following deposition of the sacrificial material **16**, the thickness of the sacrificial material **16** must at least meet and more preferably exceed the intended final thickness of that layer **12** in which it is being deposited.

[0093] According to the present invention, the accuracy, precision and characteristics of the process by which the model material **14** is removed from the build layer **12M**, during step **18E** discussed above, determines the accuracy and the precision of the final model **10** because the vertical side wall of either the model material **14**, exposed by the removal process described above, or the exterior vertical side wall of the boundary generally forms an exterior perimeter surface **24** for the final model **10** and may also form an exterior surface **24** of the final model **10** on a preceding layer **12**. In many applications, it is desirable to employ a milling tool, or some other similar but comparable mechanical material removal process or technique, in order to achieve the

desired accuracy and precision equal to current high-end machining processes. It is to be appreciated that other material removal techniques, such a laser cutting or vaporization, for example, may also be utilized as long as the depth can be sufficiently controlled so as not to extend or protrude into the channel, trough fabricated build layer **12M**. Regardless of the type or kind of material removal process utilized, the quality of the outwardly facing model material **14** surfaces, resulting from the material removal process, will determine the overall surface quality and accuracy of the final model **10** to be fabricated.

[0094] The width of the removal area(s), channel(s) or region(s) **22R** created, for example, along a surface **24** of the model **10** by the selective material removal process, that is, the width of the resulting sacrificial material inlay area **22S**, determines the thickness of the encapsulating boundary and the minimum spacing distance between the model features within each layer. The removal area(s), channel(s) or region(s) **22R** must be sufficiently wide to accommodate the subsequent deposition of the sacrificial material **16** at a uniform density and so as to entirely and completely fill each removal area(s), channel(s) or region(s) **22R** without leaving any gap(s), crack(s), opening(s) and/or void(s) therein that could be permeated during the subsequent removal of the extraneous model material **14**. The removal area(s), channel(s) or region(s) **22R** must also be sufficiently narrow to permit the desired spacing distance between adjacent features of the composite model **10C**.

[0095] As will be understood by those of ordinary skill in the relevant art, the width of the removal area(s), channel(s) or region(s) **22R** and of the resulting inlay area **22S** can be established by the size or energy of the selected removal process, the number of removal passes utilized, and so forth. It will also be understood that the selective removal and cleaning process must result in adequate cleaning of each removal area(s), channel(s) or region(s) **22R** so that it is substantially completely free from any dust, particles and/or debris because if any such dust, particles and/or debris remain within the removal area(s), channel(s) or region(s) **22R**, during the subsequent deposition of the sacrificial material **16**, this may possibly result in a defect(s) and/or imperfection(s) occurring in the outer surface **24** of the final model **10** thereby detracting from the overall quality and precision to be obtained by the method of the present invention. Consequently, either a conventional air blowing process or more preferably a conventional vacuum process, or some other adequate dust/debris removal process, is incorporated or employed after each planing process in order to thoroughly clean each one of the removal area(s), channel(s) or region(s) **22R** and thereby ensure that all of the dust, particles and/or debris, created during formation of the removal area(s), channel(s) or region(s) **22R**, are completely removed before depositing the sacrificial material **16** and forming the sacrificial material inlays areas **22S**.

[0096] It will also be understood that during the fabrication process of the present invention, for certain geometries of the final model **10** or the composite model **10C**, extraneous model material is intentionally deposited in regions located outside of the final model **10**, that is, outside of the removal area(s), channel(s) or region(s) **22R** created by the selective removal of the model material **14** during removal step **18E**. As described, these areas of extraneous model material **14E** pro-



vide a solid support structure upon which other features of the composite model 10C, in any subsequent layer(s) 12, can be subsequently deposited.

[0097] As described, the final step in the fabrication of each build layer 12M is the removal of all of the excess model material 14 and the excess sacrificial material 16, contained within that build layer 12M, which exceeds the intended thickness of that build layer 12M and typically includes the removal of all of the sacrificial material 16 that is not located within the removal area(s), channel(s) or region(s) 22R as well as typically a minor portion of the deposited model material 14. As also described, all of the model material 14 and all of the sacrificial material 16, deposited during the fabrication of each layer 12, is deposited to thickness that at least meets, and more preferably exceeds, the minimum intended thickness of that layer 12. This ensures that when the excess model material 14 and the excess sacrificial material 16 are removed from the deposited layer, the exposed surface of the completed build layer 12M surface will be smooth, uniform and free from any voids, discontinuities or irregularities and will comprise the model material 14 with the “inlays” of the sacrificial material 16 along the surface 24 of the composite model 10 in the build layer.

[0098] The excess model material 14 and the excess sacrificial material 16, in each build layer 12M, can be removed by employing any of a number of conventional methods or techniques which including, for example, cutting, boring, grinding, drilling, routing, boring, etc. In addition, a secondary process, such as a vacuuming, a blowing and/or a dust removal process, is typically used to remove any remaining particulate matter, dust and/or debris left as a result of the primary removal process. Alternatively, both the cutting, grinding, drilling, routing, boring, etc., and the vacuuming/cleaning steps can be combined in a single pass process step. Regardless of the material removal mechanism, process or technique for removing the model material 14 during formation of the one or more the removal area(s), channel(s) or region(s) 22R, the removal process must remove all excess material uniformly, thoroughly and completely, without leaving any surface irregularities, dust, particulate matter(s) or residual smudging or contamination, of one material by the other, and the final layer thickness must be level and precise thereby leaving a clean, smooth completed surface upon which the next subsequent build layer 12M can be deposited.

[0099] As described, the terminal layer or layers 12T are generally an integral part of the encapsulating boundary that completes the enveloping of the entire final model 10 and thereby protects the final model 10 during the subsequent process or processes that are utilized or employed in order to remove the extraneous model material 14 and the sacrificial material 16 which is located on the exterior of the encapsulating boundary. It is to be appreciated that, for some applications, the last build layer 12M may complete formation of the boundary thereby avoiding the need to form any terminal boundary layers 12T. The terminal boundary layer 12T, if utilized, typically must, at a minimum, cover all areas of the composite model 10C that remain exposed upon completion of the final build layer 12M that includes part of the composite model 10C, that is, that contains the surface 24 of the final model 10. The terminal layer 12T must be deposited to a thickness that exceeds the intended final thickness of that layer 12. If more than one terminal layer 12T is required or desired, the sacrificial material 16 for each of the successive terminal layers 12T, up to the final terminal layer 12T, and that

exceeds the intended final thickness of each such successive terminal layer 12T is removed down to the intended thickness of each such terminal layer 12T so as to provide a smooth, level surface for the final terminal layer 12T.

[0100] While the above disclosure generally describes using the exterior surface of the centrally, core located model material 14 to define the overall shape of the final model 10, it is to be appreciated that the exterior surface of the encapsulating boundary can alternatively define the overall shape of the final model 10. In this case, then the process by which the final model 10 is obtained from the composite model 10C is thereby simplified since only one separation step is required, namely, process step 18I in which the extraneous model material 14E is removed from the composite model 10C and thereby leaving the encapsulating boundary, comprising the sacrificial material, which defines the final model 10.

[0101] Alternatively, while the above disclosure describes using the model material 14 as the initially applied material of the current build layer the current build layer 12M and one or more removal area(s), channel(s) or region(s) 22R are then cut, ground, drilled, routed, bored, etc., in the initially applied the model material 14 which is subsequently filled with the sacrificial material 16, it is to be appreciated that the order may be reversed. That is, the initially applied material of the current build layer 12M may be the sacrificial material 16 and one or more removal area(s), channel(s) or region(s) 22R are then cut, ground, drilled, routed, bored, etc., in the initially applied the sacrificial material 16 which is subsequently filled with the model material 14. Moreover, as indicated above, the exterior surface of the centrally located sacrificial material 16 defines the overall shape of the final model 10, it is to be appreciated that the exterior surface of the encapsulating model boundary can alternatively define the overall shape of the final model 10. In this case, then the process by which the final model 10 is obtained from the composite model 10C is thus simplified since only one separation step is required, namely, process step 18I in which extraneous sacrificial material 16 is removed from the composite model 10C thereby leaving the encapsulating boundary, comprising the model material 14, which defines the final model 10.

#### B. Further Aspects of the Method for Fabrication of a Model

[0102] Next considering further aspects of the present invention, and in particular the fabrication of a composite model 10C and the final model 10 having, for example, undercut, recesses and void features, the following will describe certain specific examples of material deposition and removal to fabricate unique construction features within the layers of interest of an exemplary composite model 10C and the final model 10.

[0103] Referring now to FIGS. 2A through 2I, further features of the method of the present invention will now be described. With reference first to FIG. 2A, this Figure is an isometric view of an exemplary model 10 having undercut and void features contained within certain build layers 12M of interest. For purposes of the following discussions, the build layers 12M of interest are identified as layers 12U, 12V, 12W, 12X, 12Y and 12Z. It will be understood that the build layers 12 represented in FIGS. 2A through 2I are not drawn to scale and are including for illustration purposes only. For example, it is to be appreciated that each composite model

10C will normally be formed by many hundreds or possibly many thousands of different sequential build layers 12M, and only a few such layers will be discussed below.

[0104] Referring first to FIG. 2B, which is a diagrammatic top plan view of the bottom most build layer 12V of FIG. 2A. As shown in FIG. 2A, the bottom most build layer 12V has a void 28A associated therewith which extends from the bottom of the composite model 10 vertically upward to build layer 12W, which is the next vertical higher build layer 12 that is deposited vertically on top of and above build layer 12V. As illustrated in FIG. 2B, all of the model material 14 in the region of the void 28A of the build layer 12V comprises a removal area, channel or region 22R where the model material 14 is removed by a suitable machining process, performed during step 18E described above. As described, this the removal area, channel or region 22R is then subsequently filled with the sacrificial material 16 in order to create a sacrificial material inlay area 22S which comprises a region of the encapsulating boundary thereby creating a supporting surface upon which the next vertically higher build layer, not labeled in FIG. 2B, is fabricated during the fabrication process of the composite model 10C. It must be noted that those layers 12, in the region of the void 28A extending from the bottom of the void 28A, commencing at build layer 12U and up to build layer 12V, also typically have sacrificial material inlay areas 22S comprising the model material removal area (s), channel(s) or region(s) 22R filled with the sacrificial material 16 which will be subsequently removed so as to thereby create the void 28A in the final model 10. These regions may also, however, be constructed as regions largely filled with the model material 14 surrounded by the sacrificial material inlay areas 22S wherein the model material 14 regions are released or exposed for subsequent removal by removal of the sacrificial materials, again thereby leaving an open void.

[0105] Further in this regard, it must be noted that certain composite models 10C may include captured voids 28, that is, a void 28 that is entirely enclosed by the model material 14. In such instances, the captured voids 28 may be left filled with sacrificial material 16 or must be “freed”, that is, connected in some manner to an external region of the sacrificial material 16 or the extraneous model material 14 to allow the subsequent removal of the sacrificial material 16 from the void 28A so as to thereby result in completion of the desired final model 10.

[0106] Referring briefly to FIG. 2C, and as discussed above with reference to FIG. 2B, the build layer 12W is the next vertical build layer 12 deposited on top of the build layer 12V, of FIG. 2A, which comprises a downward facing vertical surface 24 of the composite model 10C that forms the top most surface which defines the top of the void 28A. In at least the region of the void 28A, therefore, build layer 12W comprises the build layer of the model material 14 deposited on the sacrificial material 16 comprising the corresponding region of build layer 12V.

[0107] Referring now to FIG. 2D, formation of a different void within the final model 10 will now be described. According to this embodiment, the build layer 12X includes a void 28B running or extending through the length of the composite model 10C where at least the model material 14 comprising a removal area, channel or region 22R of the layer 12X in the area of the void 28B at the top of the void 28B is removed, thus forming the top surface of the void 28B. This removal area, channel or region 22R is indicated by the dark area of the

build layer 12X, in FIG. 2D, and comprises a region of build layer 12X within the composite model perimeter defined by the inner surface 24 of the composite model 10C in this region. As in the case of the void 28A and the build layer 12V discussed above, this removal area, channel or region 22R is then subsequently filled with the sacrificial material 16 to create the sacrificial material inlay area 22S and comprises a region of the encapsulating boundary at the bottom of the void 28B, thereby creating a supporting surface upon which the next vertically higher layer is fabricated on during the fabrication process.

[0108] Lastly now referring to FIG. 2E, formation of a further type of void within the final model 10 will now be described. According to this embodiment, the build layer 12Y of the model 10 essentially does not contain any features, and essentially comprises build layers 12Y of the model material 14 having outside extent bounded by the perimeter surface 24 of the build layers 12Y. As such, the model material 14 of the build layer 12Y remains intact with the exception of the removal area 22R trench which excavated along the inside and the outside perimeter surfaces 24 of the composite model 10C, which is subsequently filled with the sacrificial material 16 to form the sacrificial material inlay area 22S comprising portions of the encapsulating boundary 22 which encloses the final model 10.

[0109] Now referring to FIGS. 2F and 2G, and as described above, the result of the above described model fabrication method is a laminated, composite structure 10C that comprises the build layers fabricated from the model material 14 and the sacrificial material 16 that are adhered to one another and are typically sandwiched between one or more foundation layers 12F and possibly one or more terminal layers 12T. As illustrated in FIG. 2G, the laminated structure of the composite model 10C contains the final model 10, generally at its core, and comprises exclusively of the model material 14 embedded inside a protective exterior boundary that generally comprises exclusively the sacrificial material 16. As also illustrated in FIG. 2G, the sacrificial boundary may be at least partially embedded in an outer covering comprising extraneous model material 14E that is located outside of the outermost removal areas 22R from which the model material 14 was removed during the fabrication process of each layer 12.

[0110] According to the present invention, and in those instances where the model 10 is encapsulated in the encapsulating boundary of the sacrificial material 16 which is at least partially enclosed within one or more bodies of the extraneous model material 14E, as in the exemplary composite model 10C shown in FIGS. 2F and 2G, a two step removal process is generally utilized to extract the final model 10 from the composite model 10C. During the model extraction process, the first step 18I generally comprises removal of the extraneous model material 14E that was deposited and located outside of the protective boundary, either to provide support for subsequent layers 12 or simply as excess deposited material. The extraneous model material 14E, that either surrounds and/or encloses the encapsulating boundary of the sacrificial material 16, is removed by using a process that does not affect the sacrificial material 16, such as a chemical solvent that only dissolves the model material 14, that is, the extraneous model material 14E, but does not affect or dissolve the sacrificial material 16. Other possible processes for removing extraneous model material 14E, without affecting sacrificial material 16, may include, for example, mechanical means or mechanisms, such as a machining or a routing

process. The resulting removal of the extraneous model material **14E**, from a composite model **10C**, is generally diagrammatically shown in FIG. **2H**, which is a diagrammatic cross section of the composite model **10C** from which the extraneous model material **14E** was removed.

[0111] The second step **18J** of model extraction process is the removal of the encapsulating boundary of the sacrificial material **16** and this typically employs a process that only affects the sacrificial material **16**, but does not affect the model material **14**. Examples of such processes for the removal of the sacrificial material **16** include a chemical solvent that dissolves the sacrificial material **16** but does not dissolve or otherwise affect the model material **14**, or the use of a sacrificial material **16** which has a lower melting point or temperature than the melting point or temperature of the model material **14**. The result of removing the encapsulating boundary of the sacrificial material **16** from the composite model **10C** is shown in FIG. **2H**, which is cross section of the composite model **10C** following removal of the sacrificial material.

### C. Further Embodiments of the Invention

#### 1. Reinforcement of the Sacrificial Material by the Model Material in Layers

[0112] As described above, and according to the present invention, the build layers **12M**, **12U**, **12V**, **12W**, **12X**, **12Y** of the composite model **10C** typically comprise of the sacrificial material **16**, as in foundation layers **12F** and the terminal layers **12T**, or more rarely only the model material **14**, or more typically primarily the model material **14** with relatively small inlays **22S** comprising the sacrificial material **16** defining the surfaces **24** of the final model **10**. In certain instances, however, the structure and features of the final model **10** are such that one or more layers **12** may include one or more areas comprising large inlays **22S**, such as in the case of the build layer **12V** of the exemplary model **10** discussed above with reference to FIG. **2B**. In other instances, and perhaps more commonly, the model **10** structure and features may be such that the first or the first few build layers **12M** of the composite model **10C**, that is, the lower most build layer or layers **12M** of the model **10**, or the upper most build layer or layers **12M** of the model **10**, adjacent the terminal layer or layers **12T**, may include one more large voids **28** starting at the first build layer **12M** of the model **10**, so that the first layers **12M** of the model **10** include relatively small areas of the model material **14** and would thus include relatively large areas of the sacrificial material **16**. An example of such design is shown, for example, in FIG. **2B** where the void **28A** extends downward to the lowest build layer **12M** of the composite model **10C**.

[0113] The build layers **12** of the composite model **10C**, constructed entirely or primarily or in large areas from the sacrificial material **16**, may, however, result in a relatively large, thin and possibly unsupported layer **12**, particularly following removal of the extraneous model material **14E** from the composite model **10C** structure, resulting in a build layer **12** that is relatively weak, unsupported and subject to damage from handling during removal of the extraneous model material **14E** and the sacrificial material **16**. While damage to the foundation layer **12F** or the terminal layer **12T** is often in itself inconsequential, it is to be appreciated that the damage can extend into the critical areas of the encapsulating boundary adjacent to model features and possibly compromise the integrity of the encapsulating boundary.

[0114] In such instances, and as illustrated in FIG. **3A** for the case of the foundation layer **12F** adjacent the void **28** such as illustrated in FIG. **2B**, the layer **12** in question may be fabricated using both the model material **14** and the sacrificial material **16**, rather than exclusively or primarily from the sacrificial material **16**. In such cases, the deposition of the sacrificial material **16**, that is, the areas occupied by the sacrificial material inlays **22S**, is generally limited to those areas adjacent to the features of the final model in the build layer **12M**. That is, to those areas adjacent to surfaces **24** which will form the final model **10** and possibly to surrounding areas of the extraneous model material **14E**, and the model material **14** remains in the remainder of the build layer **12** areas, e.g., it is not removed from the build layer **12M**. This method typically provides a stronger support layer as well as a more reliable separation between the sacrificial material **16** and the model material **14** of that build layer **12M** and in the adjacent layers **12** and provides better protection to the encapsulating boundary which either forms the composite model **10C** or encloses and protects the composite model **10C**. Depositing one or more smaller regions of the sacrificial material **16** in the layer **12** in question, but only adjacent to the model features in the build layer, while leaving a balance of the build layer **12M** unaffected reduces the risk of unintended damage to the encapsulating boundary by eliminating thin unsupported portions of the encapsulating boundary and facilitates faster completion of the build layer **12M**.

#### 2. Fabrication of Reentrant Angles

[0115] The surfaces **24** of the composite model **10C** may commonly include one or more reentrant angles, also referred to as interior angles, which are often defined as the intersection of two lines or surfaces having faces exterior to at least a local region of the model and that intersect at an angle of  $180^\circ$  or less. An example of such a reentrant angle is illustrated in FIG. **3B** for the build layer **12M** of the composite model **10C** having the form, on at least that build layer, of a wall **32** comprising multiple segments **32W**. As shown, each intersection of two wall segments forms a local region **34L** of the composite model **10C** having an exterior angle **34E** (e.g., reentrant angles **34R**) that is equal to or greater than  $180^\circ$  and an interior reentrant angle **34R** of  $180^\circ$  or less (e.g., reentrant angles **34R**).

[0116] Reentrant angles **34R** in the surfaces **24** of the composite model **10C** are a recurring problem in systems where the features of the composite model **10C**, that is, the surfaces **24** of the model **10**, are defined or formed by the machining processes because the tools by which such surfaces are defined or formed, such as milling devices, are typically not capable of forming such acute interior angles. That is, machining tools such as milling devices, typically comprise a cylindrical rotating, cutting or grinding heads, tips or surfaces having at least a small but defined cutting or grinding radius. As a result of such design, as more specifically illustrated in FIG. **3C**, such machining tools typically leave a curved fillet **36** in the reentrant angle **34R** formed by the intersection of two intersecting surfaces **24** of the composite model **10C**. Such fillets **36** are generally equal in size to the radius of the milling device or other machining tool. While it is possible to use a smaller radius tool and thereby produce a smaller fillet **36**, the use of a smaller machining tool is time consuming and still does not, and cannot, completely eliminate the fillets **36** but merely reduces the radius of curvature of the fillet(s) **36**. A smaller machining tool size also introduces a tradeoff

between the fillet **36** size and the number of machining passes that are required to remove the desired model material **14** along and adjacent to the external model surfaces **24**.

[0117] While it is possible to reduce the net effects of this tradeoff by using more than one machining tool diameter, the use of multiple machining tools, including multiple or changeable tools, adversely affects both the time, cost and reliability of the system for fabricating composite models **10C**. Consequently, while using one or more machining tools may be viable in some implementations and applications, it is generally not acceptable for high precision model fabrication or applications where minimizing fabrication time is important.

[0118] A further embodiment and implementation of the present invention, however, permits the fabrication of reentrant angles **34R** formed by the intersection of two mating surfaces **24** of the composite model **10C** without formation of any fillets **36** by a reentrant angle fabrication process **18D'** which is preformed immediately prior to fabrication of any build layer **12M** that includes at least one reentrant angle **34R** in at least one surface **24** of the composite model **10C**. The reentrant angle fabrication process **18D'** first includes a fillet material deposition step which is executed prior to the model material deposition step **18D**, illustrated herein above in FIG. 1E, for example.

[0119] According to the present invention, and as illustrated in FIG. 3D, the material deposition step of the reentrant angle fabrication process **18D'** includes the initial deposition of a reentrant sacrificial material **16R**, at the precise locations to at least fill the fillet space **36S** with a desired reentrant angle filler **34F**, e.g., a separation material such as a reentrant sacrificial material **16R**. As illustrated in FIG. 3D, the two mating and intersecting sides each of the reentrant angle filler **34F** precisely conform to and define a portion of the exterior intersecting surfaces **24** of the composite model **10C** of the reentrant angle **34R** and, on a third side, at least fills the space which would be occupied by the fillet **36** if the angle had been shaped by a machining process rather than by the reentrant angle fabrication process **18D'**. The reentrant angle filler **34F** is deposited so as to have a sufficient thickness that, as in the case of the subsequent deposition of the model material **14** and then the sacrificial material **16**, to complete formation of the sacrificial material inlay areas **22**. That is, the reentrant angle filler **34F** has a height at least equal to or preferably greater than the intended final thickness of the build layer **12M**.

[0120] According to the present invention, the reentrant sacrificial material **16R** may comprise the same sacrificial material **16** that comprises the sacrificial material inlay areas **22S** and the encapsulating boundary, or may be comprise a different sacrificial material **16R** that is removable by a process that does not affect the sacrificial material **16** and/or the model material **14** and that is not affected by the processes used to remove the sacrificial material **16** or the extraneous model material **14E**.

[0121] It will also be noted that reentrant sacrificial material **16R** must comprise a material, and must be deposited by a process, that allows the deposition of the reentrant sacrificial material **16R** with the precision and within necessary tolerances that satisfy the dimensional requirements required to define and construct the surfaces **24** and the reentrant angle **34R**. In general, these requirements may be met, for example, by the use of a drop-on-demand inkjet printing mechanism or other similar or equivalent mechanism and deposition process

or technique. Following deposition of the reentrant sacrificial material **16R**, then the build layer **12M**, e.g., the model material **14** as also illustrated in FIG. 1E, is then deposited on top of the deposited reentrant sacrificial material **16R** and selected areas are then removed as discussed above, by steps **18D** to **18G**. It is to be appreciated that if the exterior surface of the boundary is to define the exterior surface of the composite model **10C**, then the reentrant angle **34R** of interest will be the exterior angles **34E** (e.g., outwardly facing reentrant angles **34R**) instead of the inwardly facing the reentrant angles **34R**.

[0122] The process of the present invention, for constructing sequential build layers **12** is continued, on a layer-by-layer basis, until completion of the entire composite model **10C**, including the deposition of reentrant sacrificial material **16R**, the deposition and machining of the build (e.g., model) material **12M**, the deposition of the separation (e.g., sacrificial) material and the planing of the deposited materials, as necessary, to complete construction of the composite model **10C**.

[0123] In this regard, it will be noted that when the model material **14** is deposited onto any build layer **12M** having one or more exterior angles or interior angles, i.e., reentrant angles **34R**, that are either greater than or equal to  $180^\circ$  or less than or equal to  $180^\circ$ . The interior or the exterior "fillets" **36**, formed of the reentrant sacrificial material **16R** in each reentrant angle **36R**, will comprise a mold to form the model material **14** being deposited into corresponding surfaces **24** having the shape and dimensions of the reentrant angles **36R**.

[0124] Subsequently, when each build layer **12** is then machined to remove the model material **14** from the removal areas **22R** in preparation for the deposition of the sacrificial material **16** to form the sacrificial material inlay areas **22S**, the machining process possibly may remove a small portion of the interior or the exterior fillets **36** but will generally leave a majority of the fillets **36** unaffected, e.g., the interior fillet **36** as shown in FIG. 3C.

[0125] As described above, the reentrant angle fabrication process further includes a subsequent material removal step executed in association with the extraneous model material **14E** and/or the sacrificial material **16** removal steps **18I** and/or **18J**. In brief, the reentrant sacrificial material **16R** is removed by the corresponding process appropriate for the reentrant sacrificial material **16R** while the extraneous model material **14E** and the sacrificial material **16** are removed by the processes appropriate for removal of those materials. The sequence in which the various materials are removed remains generally as described above except that the reentrant sacrificial material **16R** is removed at a point in the material removal process that is dependent upon the disposition of the materials in the composite model **10C**. In general, the interior reentrant sacrificial material **16R** will be enclosed within the sacrificial material **16**, at least parts of which may be enclosed within extraneous model material **14E**, if any, and as such would be removed after removal of the extraneous model material **14E** and either with the sacrificial material **16** or possibly after removal of the sacrificial material **16**, though another separate removal process is less desirable. Any exterior reentrant sacrificial material **16R** will be generally exposed along with the sacrificial material **16** and as such can be removed along with the sacrificial material **16**, after removal of the extraneous model material **14E**. Alternatively, the exterior reentrant sacrificial material **16R** will be generally exposed along with the sacrificial material **16** and thereby

define a portion of the outer surface of the boundary, which defines the outer surface of the composite model **10C**, in the event that the boundary is to be retained and define the outer surface of the composite model **10C**.

[0126] Lastly, it will be recognized by those of ordinary skill in the relevant art that the reentrant angle fabrication process of the present invention, as described above, may also be employed to form and fabricate model features and details that are too fine or too close to be formed using conventional machining methods.

### 3. Fabrication of a Model Using Non-Horizontal Layers

[0127] The above descriptions of the fabrication of the composite model **10** assume that the foundation layer **12F** and thus all subsequent build layers **12M** of the composite model **10C** are fabricated on and parallel to a base plate or other support surface or table **T**, **40W**, as described below, which is in turn parallel to a reference base plane which will typically be horizontal. For convenience and the purposes of the following descriptions, the build layers **12** of the composite model fabricated in this manner and the corresponding reference base plane will be referred to as “horizontal” build layers **12** and a “horizontal” reference base plane.

[0128] In certain circumstances, however, the fabrication of a composite model **10C** by horizontal build layers **12** formed on a horizontal base plane may be disadvantageous. For example, the design of a given model **10** may require the deposition of large amounts of the build (e.g., model) material **14** or separation (e.g., sacrificial) material **16** by selective processes, which as discussed above are more time consuming than by non-selective processes, or the removal of large amounts of model material **14** or sacrificial material **16**, which is again time consuming, either of which may result in an increase in fabrication time and costs. In other instances, the composite model **10C** may contain one or more surfaces which are at an angle to at least the horizontal base plane and possibly to other surfaces of the composite model **10C** and in certain instances, in particular, the “slanted” surfaces may comprise more area than do the “horizontal” surfaces of the composite model **10C**.

[0129] In such instances, and according to the present invention, the base plane upon which the composite model **10C** is formed, that is, the base plate or support surface of the fabrication system in which the composite model **10C** is created, may be tilted with respect to the horizontal reference plane to be parallel with, for example, the slanted surfaces of the composite model **10C** and the layers **12** formed with a tilted base plane will thereby be effectively “horizontal” with respect to each other and will accordingly be at an angle other than 90 degrees with respect to, for example, the vertical surfaces of the composite model **10C**. It must be noted that any horizontal or vertical surfaces of the composite model **10C** which were originally parallel to or vertical to the original horizontal base plane will now be at an angle with respect to the tilted base plane, so that surfaces running across the slant of the tilted base plane will now appear as lines across successive build layers **12** of the composite model **10C**. In a like manner, vertical surfaces running along the tilted base plane will appear on successive tilted build layers **12** as points, short lines, small surfaces, etc. In any event, what was originally a relatively large surface(s) or line(s) of the composite model **10C**, when the build layers **12M** were formed parallel to a horizontal base plane, will be reduced to relative

short segments of lines or surfaces, thereby potentially significantly reducing the amount of selective material deposition or removal in the build layers **12M** for each build layer.

### D. An Exemplary System for the Fabrication of Models

[0130] An apparatus for performing certain of the basic processes for fabricating composite three dimensional models are illustrated in, for example, U.S. Pat. No. 7,700,016 issued to Wigand et al. on Apr. 20, 2010 for a Method And Apparatus For Fabricating Three Dimensional Models and U.S. Pat. No. 7,993,123 issued to Wigand et al. on Aug. 9, 2011, also titled Method And Apparatus For Fabricating Three Dimensional Models, both of which are incorporated herein by reference. The following will describe an improved version of the apparatus described in U.S. Pat. Nos. 7,700,016 and 7,993,123, wherein the improved apparatus includes the capability of performing, in particular, the processes described herein. The improved apparatus described herein below will also include methods and mechanisms of the present invention for the establishment, monitoring and control of the positions, orientations and positional and orientational tolerances of and between the elements of an apparatus for fabricating three dimensional models from successive layers of model and sacrificial materials, including establishing, monitoring and controlling the thicknesses, rates of deposition and edge orientations and tolerances of the deposited materials.

[0131] Referring now to FIGS. 4A-4C, isometric and diagrammatic views of a three dimensional model fabrication system **38** incorporating the present invention are shown. As shown therein, the fabrication system **38** includes a vertically positional workpiece platform **40W** for supporting a composite model **42** being fabricated and a tool platform **40T** that is supported above workpiece platform **40W** and supports a plurality of fabrication tools **44**, such as material deposition devices **46**, such as material deposition devices **46A**, **46B** . . . **46Z** and one or more milling tools **48**, such as milling tools **48A**, **48B** . . . **48Z**. It must be recognized and understood with regard to the following descriptions of the present invention that the number and locations of material deposition devices **46** and/or milling tools **48** on or in a tool platform **40T** may, in any given embodiment of the present invention, vary significantly from that shown in FIG. 4A-4C while remaining within the spirit and scope of the present invention.

[0132] Workpiece platform **40W** is vertically positional along a vertical Z axis **40Z** with respect to a generally horizontal tool plane **40XY** while tool platform **40T** is supported vertically above workpiece platform **40W** along the tool plane **40XY**. In a presently preferred embodiment, the tool platform **40T** is supported on and is positional along a Y-axis rail **50Y** that extends along a horizontal y-axis **40Y** in tool plane **40XY**. The opposing ends of Y-axis rail **46Y** are, in turn, supported upon and are positional along a pair of corresponding generally horizontal X-axis rails **50X** that are located on opposite sides of workpiece platform **40W** and that extend parallel to a horizontal X-axis **40X** in the tool plane **40XY** that is orthogonal to Y-axis **40Y** in the tool plane **40XY**.

[0133] The tool platform **40T**, with fabrication tools **44**, is thereby positional anywhere within the tool plane **40XY**, which is typically parallel to the composite model **42** and, in particular, the currently top most layer of the composite model **42**, which is, in turn, vertically positional along Z axis **40Z** with respect to tool plane **40XY**. It should be noted,

however, that while the layers of the composite model **42** are parallel to tool plane **40XY** as a consequence of each successive layer being deposited and shaped by the tools **44** mounted on the tool platform **40T** and thereby restrained to tool plane **40XY**, the plane of workpiece platform **40W** is not necessarily parallel with tool plane **40XY**. As will be discussed below, and while the orientation of the plane of workpiece platform **40W** is controllable with respect to the tool plane **40T**, there may be circumstances in which it is advantageous to angularly offset the orientation of the plane of the workpiece platform **40W** with respect to the tool platform **40T**.

[0134] According to one embodiment of the fabrication system **38**, and as illustrated in FIGS. **4A-4C**, the workpiece platform **40W** may be designed and adapted to receive and secure a workpiece support plate **40S**, which comprises, for example, a metal plate engaging into an opening or recess in workpiece platform **40W** and retained therein by workpiece support platform latches **40L** with the upper surface of workpiece support plate **40S** being positioned generally parallel to and offset from the tool plane **40XY**. A replaceable workpiece base **40B**, which comprises, for example, a relatively dense and typically non-porous or closed cell foam or plastic material which has a relative smooth, typically non-absorbent, upper surface, may be removably mounted upon workpiece support plate **40S**, with the composite model **42** being fabricated on the upper surface of the workpiece base **40B**.

[0135] It will be seen, therefore, that workpiece base **40B** and workpiece support plate **40S** perform a number of functions, such as providing a mechanism or means for handling a finished composite model **42** without damage to the composite model **42**, such as removing the composite model **42** from the fabrication system **38** for subsequent processing, e.g., removing the extraneous model material and/or the separation material. In addition, the workpiece base **40B** provides an offset between the tool platform **40T**, the fabrication tools **44** and the planing device **62**, described below, and the workpiece platform **40W**, thereby preventing an inadvertent interaction, wear and/or damage between, for example, the fabrication tools **44** or the planing device **62** and the workpiece platform **40W**. The material of a workpiece base **40B** may also provide a preferred surface for the mounting and removal of the composite model **42**, and may provide a surface that can be readily planed, such as by the planing device **62**, so as to be precisely parallel with the tool plane **40XY**. A workpiece base **40B** also provides a readily and cheaply disposable mechanism for protecting the workpiece platform **40W** and the workpiece support plate **40S** from wear and contamination or from accumulation of, for example, the sacrificial and/or the model material during the fabrication processes.

[0136] As indicated in FIGS. **4A-4C**, the vertical position of the workpiece platform **40T**, with respect to the tool plane **40XY** and thereby with respect to the fabrication tools **44**, is adjustable and controlled by a Z axis actuator **52Z** while the horizontal position of the tool platform **40T** along Y-axis **40Y** and X-axis **40X** of the tool plane **40XY** are respectively controlled by a Y-axis actuator **52Y** and an X-axis actuator **52X**. It will also be appreciated that there are a variety of Z-axis actuator(s) **52Z**, Y-axis actuator(s) **52Y** and X-axis actuator(x) **52X** which are designed and capable of meeting these requirements, such as rotationally driven screw shafts with or without carriage guidance tracks, rack and pinion mechanisms, belts and pulleys, etc., all of which are well known to those of ordinary skill in the art and may be

employed in place of the exemplary designs described herein. As such, the Z-axis actuators **52Z**, the Y-axis actuators **52Y** and the X-axis actuators **52X** need not be described in further detail herein and are accordingly represented, in FIGS. **4A-4C**, in diagrammatic form.

[0137] Referring, therefore, to the requirements and functions of the Z-axis actuators **52Z**, the Y-axis actuators **52Y** and the X-axis actuators **52X**, it will be recognized that the Z-axis actuator **52Z** is required to both support and move the workpiece platform **40W** along the Z-axis **40Z** with a high degree of precision and repeatability and to maintain the orientation of the plane of workpiece platform **40W** with respect to the tool plane **XY** at all positions along the Z-axis **40Z** and under varying loads placed on workpiece platform **40W**, some of which may be off center with respect to the workpiece platform **40W**. Because of these requirements, and for example, the Z-axis actuator **52Z** may comprise a rotationally driven vertically oriented screw shaft coupled to, for example, a bottom edge region of the workpiece platform **40W** with the workpiece platform **40W** being restrained in the horizontal orientation by multi-point roller bearings mounted onto the workpiece platform **40W** and engaging with corresponding vertically oriented bearing tracks located along opposing sides of the workpiece platform **40W**.

[0138] It will also be recognized that the requirements of and thus the designs for the Y-axis actuator **52Y** and the X-axis actuator **52X** may be different from those of the Z-axis actuator **52Z** because, for example, the tool platform **40T** is supported by the horizontally oriented Y-axis rail **50Y** and the Y-axis rail **50Y** is, in turn, supported by the horizontally oriented X-axis rails **50X** while the workpiece platform **40W** is supported during vertical movement and positioning. As such, the Y-axis actuator **52Y** and the X-axis actuator **52X** may comprise, for example, rotationally driven horizontally oriented screw shafts or rack and pinion mechanisms, belts and pulleys, etc., and may include or incorporate any of a variety of position sensors and indicators, a wide variety of which will be well known to those of ordinary skill in the relevant art.

[0139] It must also be recognized that in other embodiments of the fabrication system workpiece platform **40W** may be horizontally and vertically fixed and the tool platform **40T** may be vertically and well as horizontally positional. The modifications to the tool platform **40T** to provide vertical as well as horizontal positioning of tool platform **40T** will, however, be well understood by those of ordinary skill in the relevant art and may comprise, for example, supporting the X-axis rails **50X** on a vertically positional support, possibly similar to that used for the workpiece platform **40W** in the embodiment described herein above.

[0140] Referring again with reference to the tool platform **40T**, it will be noted that the tool platform **40T**, as illustrated in FIG. **4A**, supports at least two material deposition devices **46**, indicated as material deposition devices **46A** and **46B**, which, in a typical embodiment will comprise at least one drop-by-drop material deposition device **46** and typically at least two high deposition rate device **46**, such as spray devices. Such fabrication system **38**, as described herein above, is has the capability of fabricating reentrant surface angles without fillets **36**. It is to be understood, however, that the tool platform **40T** may include more or less deposition devices **46**. It must also be understood that not only may the number of material deposition devices **46** vary, from embodiments of the fabrication systems **38** and the tool platforms

40T, but that the combinations of material deposition devices 46 may vary depending upon the requirements of the composite models 42 to be fabricated.

[0141] Where the fabrication system 38 has the capability of, for example, performing the “trench and fill” method for delineating model surfaces, the tool platform 40T will further include and support at least one milling tool 48, as described herein above, but possibly may include two or more milling tools 48A, 48B . . . 48Z to allow, for example, both fast, rough-out milling and finer precision milling or to otherwise accommodate a variety of different milling tool types and sizes. In addition, the milling tools 48 may be constructed as individual milling tools or as one or more milling tools, each of which may have two or more milling heads. In either case, the milling tool 48 or the milling head of a single milling tool 48 may be selected and engaged with a motor and/or engaged with the current build layer the current build layer 12M of the composite model 42 by, for example, an axial solenoid actuator. As in the case of material deposition devices 46, the number, type, combinations thereof and locations of the milling tools 48 on the tool platform 40T may vary between embodiments of fabrication systems 38 and the tool platforms 40T, and that the types and combinations of milling tools 48 may vary depending upon the requirements of the composite models 42 to be fabricated.

[0142] As described above, the fabrication tools 44, including material deposition devices 46 and the milling tools 48 together with other elements of the tool platform 40T described below, all being mounted on the tool platform 40T, are thereby jointly positional along the X-axis 40X, the Y-axis 40Y and the Z-axis 40Z with respect to the workpiece platform 40W and the layers of the composite model 42 thereupon by means of the single actuator group which comprises the X-axis actuator 52X, the Y-axis actuator 52Y and the Z-axis actuator 52Z. It will also be apparent that, for each position taken by the tool platform 40T along the X-axis 40X, the Y-axis 40Y and the Z-axis 40Z, each of the fabrication tools 44 mounted on the tool platform 40T will have a different “target point”, that is and for example, the point at which the corresponding material from the material deposition device 46 is deposited on the current top most layer of the composite model 42 or at which the tool bit of the corresponding milling tool engages with the current top most layer of the composite model 42. According to the present invention, the offsets along the X-axis 40X, Y-axis 40Y and Z-axis 40Z between a position of the tool platform 40T, or a selected reference point thereupon, and the current “target points” of each of the fabrication tools 44 or other elements mounted thereupon is accommodated and compensated for in the programming of a system controller 54 which controls all operations of the fabrication system 38, including the positioning of the workpiece platform 40W and the tool platform 40T and all operations of the fabrication tools 44 as well as other elements of the fabrication system 38, described herein.

[0143] Lastly with regard to the tool platform 40T, and as shown in FIG. 4A, each material deposition device 46 requires a material feed connection 56 to a corresponding material supply reservoir 58 where the material feed connection 56 is typically heated to insure flow of the material provided therethrough to the material deposition device 46, and a control and power connections 60 between the system controller 54 and the material deposition device 46 to communicate control and power signals between the system controller 54 and the material deposition device 46. The milling

tool 48 will similarly require a control and power connection 60 to the system controller 54 to communicate power and control signals between the system controller 54 and the milling tool 48. Such connections and their functions are, however, well known and customary in the art and not discussed in further detail, including those for elements other than the fabrication tools 44 mounted on the tool platform 40T and which will require material, power or control connections.

[0144] As also shown, and as described herein above and in U.S. Pat. Nos. 7,700,016 and 7,993,123, the fabrication system 38 will further include the planing device 62 for removing a portion of a deposited layer of the sacrificial mold material and the model material to reduce the layer to a selected thickness to thereby establish the plane of the upper surface of the build layer and to expose the upper surfaces of the sacrificial material and the model material in preparation for the deposition of the next build or termination layer.

[0145] According to one embodiment of the fabrication system 38, and as illustrated in FIG. 4A, the planing device 62 is typically mounted a planing carriage 62C which, in turn, is mounted upon and moveable along the x-axis rails 50X. The planing device 62 comprises, for example, a helical rotary cutter having a horizontal axis of rotation orthogonal to the X-axis rails 50X to plane the currently upper most layer of a composite model 42 along a plane parallel to the tool platform plane 40XY. The fabrication system 38 will also typically include a vacuum connection 62V for extracting and disposing of any cut and removed material from the build layer of the composite model, such as the debris produced by the planing device 62, and possibly removing overspray material from material deposition devices 46A, 46B . . . 46C.

#### E. Simultaneous Scribing and Filling

[0146] With reference now to FIGS. 5A-5C, a detailed description concerning the present invention will now be provided. As briefly described above in the summary of the invention, the principal advantage of the present invention is the combination of two of the above described steps with one another in a single step, namely, the combination of the mechanical material removal step/process with the material filling step/process with one another. That is, both of those steps/processes are combined with one another in a single combined device and/or a single combined method so that both steps/processes are performed substantially simultaneously with one another thereby eliminating one of those processing steps and saving valuable production time.

[0147] The present invention is particularly useful with respect to creating large support area or areas, comprising both the build/model material and the separation/sacrificial material, which provide support for fabrication of the composite model but is/are subsequently removed/dissolved away, during a subsequent removal process, thereby leaving the final model. That is, the support structure can be fabricated entirely of the separation/sacrificial mold material, or can be fabricated as a three dimensional grid of both separation/sacrificial mold material with the interior spaces of the grid being filled with the model material (see FIGS. 3A, 3C and 3D, for example). A further description concerning fabrication of such support area or areas is found in U.S. Pat. No. 7,700,016, and the teaching and disclosure of such reference is incorporated by reference in its entirety.

[0148] A detailed description concerning the combined scribing/filling device 64, according to the present invention,

as shown in FIG. 5C, will first be provided and this will then be followed by a detailed description concerning the method of using the combined scribing/filling device 64. The combined scribing/filling device 64 (e.g., a scribing tool 66 incorporated into a high viscosity material deposition head or device, a high flow deposition device or a high rate deposition device) is suitable for controllably dispensing either the build/model and/or the support/sacrificial material 16, 18 at flow rates approximating, or exceeding, those of rapid deposition devices currently known in the prior art and utilized for rapid deposition of conventional lower viscosity materials.

[0149] The combined scribing/filling device 64 generally comprises a high viscosity rapid deposition head 68, see FIGS. 5B and 5C, which includes an elongate deposition body 70, typically manufactured from metal or some other heat conducting material. The deposition body 70 has a generally cylindrical transverse cross-sectional shape but may have a variety of other transverse cross sectional shapes, e.g., such as square, oval, polygonal, etc. In addition, the combined scribing/filling device 64 includes a scribing tool 66, e.g., a conventional screw in FIGS. 5B, 5C and 6, which is received and accommodated within an internal cavity 72 of the deposition body 70. As will be discussed further below, at least the scribing tool 66 (either alone or along with a remainder of the combined scribing/filling device 64) is vertically movable along the Z-axis with respect to the layer currently being fabricated 12. That is, at least the scribing tool 66 may be moved either toward or away from the layer currently being fabricated 12 (as shown by the double arrow on the left in FIG. 6), depending upon the specific implementation of the fabrication system, or, alternatively, the support table T may be movable either toward or away from the at least the scribing tool 66. In addition, the combined scribing/filling device 64 and the tool platform 40T are laterally movable, i.e., along the X-axis and the Y-axis, with respect to the composite model being fabricated in order to perform the desired "scribing" in the layer currently being fabricated 12.

[0150] The scribing tool 66 will first be discussed and this will then be followed by a discussion concerning the high viscosity rapid deposition head 68. As shown in the FIGS. 5B and 5C, the scribing tool 66 generally comprises an elongate element, e.g., a conventional screw, which defines a longitudinal axis  $L_1$  which extends centrally from a head H or trailing end thereof to a scribing tip 74 or a leading end thereof. The scribing tool 66 is located and captively received within the internal cavity 72 of the deposition body 70, see FIGS. 5B, 5C and 6. That is, the screw thread diameter of the scribing tool 66, e.g., the screw in this instance, is slightly larger than the diameter of a supply passageway 76 so that the scribing tool 66 is fixedly retained by and within the supply passageway 76 of the high viscosity rapid deposition head 68 with the head H sufficiently spaced from an entrance of the supply passageway 76 to permit flow into the supply passageway 76. The scribing tip 74 performs the scribing function in the layer currently being fabricated 12, and a further detailed discussion concerning such scribing of the layer currently being fabricated 12 will be provided below. As diagrammatically shown, a space or an area A formed between the adjacent threads of the scribing tool 66, the valleys between the adjacent threads and the inwardly facing surface of the supply passageway 76 combine with one another to form a helical flow path which facilitates the flow of the high viscosity

(filling) material M from the internal cavity 72 of the high viscosity rapid deposition head 68 onto the layer currently being fabricated 12.

[0151] As diagrammatically shown in FIGS. 5B and 5C, the internal cavity 72 of the high viscosity rapid deposition head 68 is generally hollow and forms a flow path for receiving the high viscosity material M, supplied from a source S of the high viscosity material M (only diagrammatically shown in FIG. 5C), and dispensing the same in a controlled manner. A vertically upper section of the internal cavity 72, of the high viscosity rapid deposition head 68, has a relatively larger transverse cross-sectional area and forms a temporary storage space 78, while a vertically lower section of the internal cavity 72 has a relatively smaller transverse cross-sectional area and forms the supply passageway 76. The supply passageway 76 communicates with and terminates as a dispensing/shaping orifice 80. The dispensing/shaping orifice 80 is formed in the vertically lower most end surface 82 of the high viscosity rapid deposition head 68. The dispensing/shaping orifice 80 facilitates dispensing of the high viscosity material M, from the high viscosity rapid deposition head 68, in a desired shape and/or configuration onto the layer currently being fabricated 12, as will be described below in further detail.

[0152] The high viscosity rapid deposition head 68 typically has a longitudinal length of about  $39\text{ mm} \pm 10\text{ mm}$ . The temporary storage space 78, of the high viscosity rapid deposition head 68, typically has a diameter of about  $4.0\text{ mm} \pm 1.0\text{ mm}$  and a longitudinal length of about a diameter of about  $30\text{ mm} \pm 10\text{ mm}$ . The supply passageway 76, of the high viscosity rapid deposition head 68, typically has a diameter of about  $2.0\text{ mm} \pm 0.75\text{ mm}$  and a longitudinal length of about  $10\text{ mm} \pm 5\text{ mm}$ . The dispensing/shaping orifice 80 typically has a diameter of about  $2.0\text{ mm} \pm 0.75\text{ mm}$ . The high viscosity rapid deposition head 68 defines a central longitudinal axis  $L_2$  which extends from a trailing end thereof to the dispensing/shaping orifice 80. The longitudinal axis  $L_1$  of the scribing tool 66 and the longitudinal axis  $L_2$  of the high viscosity rapid deposition head 68 are both coincident with one another so as to facilitate simultaneous operation of both the scribing step/process and the material dispensing step/process.

[0153] As generally shown in FIGS. 5B, 5C and 6, the outer edges of the threads of the scribing tool 66 engage with the inwardly facing surface of the supply passageway 76 such that the scribing tip 74 projects centrally and slightly out through the dispensing/shaping orifice 80 of the high viscosity rapid deposition head 68 while the main body section of the scribing tool 66 is fixedly accommodated within the supply passageway 76. As generally shown in the drawings, although the threaded body of the scribing tool 66 is closely received and accommodated within the supply passageway 76, the flow path defined between the adjacent threads provides an adequate flow space or area A through which the high viscosity material M can flow, in a helical fashion, from the temporary storage space 78 toward the dispensing/shaping orifice 80, for dispensing of the high viscosity material M from the high viscosity rapid deposition head 68 onto the layer currently being fabricated 12.

[0154] The combined scribing/filling device 64 is accommodated and retained by a conventional deposition head holder 84, as generally shown in FIGS. 5A and 5C. The deposition head holder 84 is normally mounted to or supported by the tool platform 40T, in a conventional manner, and has a head receiving cavity 86 located therein. The head



receiving cavity **86** is sized and shaped to receive and securely retain the high viscosity rapid deposition head **68** therein, in a conventional manner, while also facilitating easy replacement or exchange thereof, when necessary or desired. As the deposition head holder **84** and its features are conventional and well known in the art, a further detail description concerning the same is not provided.

[0155] With reference now to FIGS. 7A-7E, a detailed description concerning a second embodiment of the combined scribing/filling device **64**, according to the present invention, will now be provided. The combined scribing/filling device **64**, according to this embodiment, generally comprises a high viscosity rapid deposition head **68**, see FIGS. 7D and 7E, which includes a deposition body **70** that is typically manufactured from metal or some other heat conducting material. The deposition body **70** has a generally cylindrical transverse cross-sectional shape but may have a variety of other transverse cross sectional shapes, e.g., such as square, oval, polygonal, etc. In addition, the combined scribing/filling device **64** includes a separate and replaceable scribing tool **66**, see FIGS. 7A-7C, which is captively received and accommodated within the internal cavity **72** of the deposition body **70**. As will be discussed below in further detail, the high viscosity rapid deposition head **68** is vertically movable along the Z-axis with respect to the layer currently being fabricated **12**. That is, at least the scribing tool **66** (and more preferably the entire combined scribing/filling device **64**) is movable either toward or away from the layer currently being fabricated **12**, depending upon the specific implementation of the fabrication system. Alternatively, the support table T may be movable either toward or away from at least the combined scribing/filling device **64**. In addition, the combined scribing/filling device **64** and the tool platform **40T** are laterally movable, i.e., along the X-axis and the Y-axis, with respect to the composite model being fabricated in order to perform the desired "scribing" of the layer currently being fabricated **12**.

[0156] With reference to FIGS. 7A-7C, it can be seen that the scribing tool **66** generally comprises an elongate member which defines a longitudinal axis  $L_1$  which extends centrally from a trailing end thereof to a leading end thereof, e.g., a tip end. The trailing end of the scribing tool **66** generally comprises a solid, cylindrical main body **88** which is correspondingly shaped and sized to fit and be received within the internal cavity **72** of the deposition body **70**, see FIGS. 7D and 7E. A leading portion of the scribing tool **66** supports a scribing tip **74** which performs the scribing function in the layer currently being fabricated **12**. An intermediate body section **90** and a transition section **92** interconnect and couple the main body **88** to the scribing tip **74**. The main body **88**, the intermediate body section **90** and the transition section **92** provides support for the scribing tip **74** while the tip is performing its scribing function described below.

[0157] As shown in FIGS. 7A-7C and 7E, the intermediate body section **90** has a smaller diameter or dimension, than that of the main body **88**, so that the intermediate body section **90** can be intimately received within the supply passageway **76**. At least one longitudinal section or area A, or more preferably two or more longitudinal slots, channel, sections or areas A of the intermediate body section **90**, i.e., having a smaller diameter or dimension than the supply passageway **76**, are provided to form a flow path for the high viscosity material M, along each slot, channel, section or area A, from

internal cavity **72** of the high viscosity rapid deposition head **68** to the dispensing/shaping orifice **80**.

[0158] The scribing tool **66** typically has a longitudinal length of about  $40\text{ mm}\pm 10\text{ mm}$ . The main body **88** typically has a diameter of about  $3.0\text{ mm}\pm 1.0\text{ mm}$  and a longitudinal length of about  $26.4\text{ mm}\pm 10\text{ mm}$ . The intermediate body section **90** typically has a diameter of about  $2.0\text{ mm}\pm 0.75\text{ mm}$  and a longitudinal length of about  $11.0\text{ mm}\pm 5\text{ mm}$ . The scribing tip **74** typically has a diameter of about  $0.5\text{ mm}\pm 0.25\text{ mm}$  and a longitudinal length of about  $1.0\text{ mm}\pm 0.5\text{ mm}$ . The transition section **92** gradually tapers or transitions, e.g., at an angle of about  $45\text{ degrees}\pm 20\text{ degrees}$ , a leading end of the intermediate body section **90** into a trailing end of the scribing tip **74**.

[0159] As diagrammatically shown, the internal cavity **72** of the high viscosity rapid deposition head **68** is generally hollow and receives the high viscosity (filling) material M, supplied from a source S of the high viscosity material M (diagrammatically shown in FIG. 7E), and assists with dispensing the same in a controlled manner. A vertically upper section of the internal cavity **72**, of the high viscosity rapid deposition head **68**, has a larger transverse cross-sectional area than the main body **88** so as to form a temporary storage space **78** formed therebetween, while a vertically lower section of the internal cavity **72** has a smaller transverse cross-sectional area than at least a portion of the intermediate body section **90** so as to form a flow passage therebetween. The supply passageway **76** communicates with and terminates as a dispensing/shaping orifice **80** which is formed in the vertically lower most end surface **82** of the high viscosity rapid deposition head **68**. The dispensing/shaping orifice **80** facilitates dispensing of the high viscosity material M, from the high viscosity rapid deposition head **68**, onto the layer currently being fabricated **12**.

[0160] The high viscosity rapid deposition head **68** typically has a longitudinal length of about  $39.0\text{ mm}\pm 10\text{ mm}$ . The temporary storage space **78**, of the high viscosity rapid deposition head **68**, typically has a diameter of about  $4.0\text{ mm}\pm 1.0\text{ mm}$  and a longitudinal length of about  $30.0\text{ mm}\pm 10\text{ mm}$ . The supply passageway **76**, of the high viscosity rapid deposition head **68**, typically has a diameter of about  $2.0\text{ mm}\pm 0.75\text{ mm}$  and a longitudinal length of about  $9.2\text{ mm}\pm 5\text{ mm}$ . The dispensing/shaping orifice **80** typically has a diameter of about  $2.0\text{ mm}\pm 0.75\text{ mm}$ . The high viscosity rapid deposition head **68** defines a longitudinal axis  $L_2$  which extends centrally from a trailing end thereof to the dispensing/shaping orifice **80**. The longitudinal axis  $L_1$  of the scribing tool **66** and the longitudinal axis  $L_2$  of the high viscosity rapid deposition head **68** are coincident with one another to facilitate simultaneous operation of both the scribing step/process and the material dispensing step/process.

[0161] As shown in FIG. 7E, the internal cavity **72** receives the main body **88** of the scribing tool **66** such that the scribing tip **74**, of the scribing tool **66**, projects out slightly through the dispensing/shaping orifice **80** of the high viscosity rapid deposition head **68**, e.g.,  $0.020$  of an inch  $\pm 0.010$  of an inch depending upon the desired precision, while the intermediate body section **90** is received and accommodated within the supply passageway **76**. As generally shown in the drawings, the main body **88** is smaller in size and/or dimension than the size and/or dimension of the temporary storage space **78** so as to provide adequate space for accommodating and storing a sufficient quantity of the high viscosity material M to be dispensed. In addition, as generally shown in the drawings,

although the transition section **92** is generally closely received and accommodated within the supply passageway **76**, the at least one longitudinal section or area **A** is smaller in size and/or dimension than a portion of the supply passageway **76** so as to provide space which forms a flow path which permits the high viscosity material **M** to flow from the temporary storage space **78** toward the dispensing/shaping orifice **80** for dispensing of the high viscosity material **M** from the high viscosity rapid deposition head **68** onto the layer currently being fabricated **12**.

[0162] The high viscosity material **M**, during dispensing, is conveyed to and forced into and through the temporary storage space **78**, located between an exterior surface of the scribing tool **66** and an inwardly facing surface of the deposition body **70** of the high viscosity rapid deposition head **68**, by a pump or a pressure source **P** of a piezoelectric element (only diagrammatically shown in FIG. 7E). Alternatively and/or in addition thereto, a flow valve **V** may be located along the supply conduit for controlling the flow of the high viscosity material **M** from the source **S** to the temporary storage space **78**.

[0163] Typically, a heating element **E** is located along at least a section of an exterior surface of the high viscosity rapid deposition head **68**, through which the high viscosity material **M** flows and passes when flowing toward the dispensing/shaping orifice **80** of the high viscosity rapid deposition head **68**. The heating element **E** maintains the high viscosity material **M** at a desired temperature and controls, along with the valve **V**, the flow of the high viscosity material **M** onto the layer currently being fabricated **12**, i.e., assist with commencing and/or discontinuing flow of the high viscosity material **M** out of the dispensing/shaping orifice **80**. As noted above, the deposition body **70** of the high viscosity rapid deposition head **68** is typically manufactured from metal, or some other heat conducting material, which facilitates conducting heat from the heating element **E**, through the deposition body **70** to the high viscosity material **M** contained therein so as to temperature control of the high viscosity material **M** and desired flow of the high viscosity material **M** through the deposition body **70** of the high viscosity rapid deposition head **68**.

[0164] As shown in FIG. 7E, a portion of the scribing tip **74**, a majority of the intermediate body section **90** and the transition section **92** are all accommodated within the supply passageway **76**. As the high viscosity material **M** flows from the temporary storage space **78** along the supply passageway **76**, the high viscosity material **M** flows between the exterior surface of the scribing tool **66**, namely, along the removed slot, channel, area or section **A** of the scribing tool **66**, and the inwardly facing surface of the supply passageway **76** until the high viscosity material **M** eventually reaches the transition section **92**. Upon reaching the transition section **92**, then the velocity of the high viscosity material **M** tends to slow somewhat and the high viscosity material **M** completely fills the entire space of the supply passageway **76**, except for the area occupied by the transition section **92** and the scribing tip **74**.

[0165] During dispensing of the high viscosity material **M**, the end surface **82** of the high viscosity rapid deposition head **68**, which defines the dispensing/shaping orifice **80**, is generally spaced from a top surface of the layer currently being fabricated **12** by a distance of less than six thousandths of an inch (0.006 inch). More preferably, the end surface **82** of the high viscosity rapid deposition head **68** is spaced from the top surface of the layer currently being fabricated **12** by a distance

of about three to four thousandths of an inch (0.003 to 0.004 inch) so as to facilitate the desired contact coating of the high viscosity material **M**.

[0166] During the mechanical removal process of removing a desired portion of the deposited material, the scribing tip **74** is typically at a somewhat elevated temperature (e.g., above room temperature) which facilitates easier carving, plowing, movement, displacement and/or possibly some melting of the material to be removed. For example, during a typical production operation, the scribing tip **74** is at a temperature of approximately 100° C.±13 or so. If the build material has a melting temperature of 115° C., for example, and the scribing tip **74** has a temperature of 100° C., then the scribing tip **74** is sufficiently warm/hot so as to render the material to be removed somewhat soft and pliant, during the carving/displacement process. As the scribing tip **74** is forced or depressed vertically into the top surface of the layer currently being fabricated **12**, e.g., either by movement of the combined scribing/filling device **64** toward the layer currently being fabricated **12** or by vertical movement of the table **T** toward the combined scribing/filling device **64**, the bottom leading surface **94** of the scribing tip **74** is forced a sufficient depth into the layer currently being fabricated **12** (see FIG. 9B). Thereafter, as the scribing tip **74** is moved relative to the layer currently being fabricated **12**, the side surface of the scribing tip **74** carves, plows, pushes and/or otherwise displaces while the bottom leading surface **94** of the scribing tip **74** assists with shearing the recently deposited and partially solidified material so as to form a desired channel, trough, trench or groove **22R** in the layer currently being fabricated **12**, which is simultaneously filled with the high viscosity material **M**, as discussed below with reference to FIGS. 9A-9E. Alternatively, it is also conceivable that the scribing tip **74** may possibly be heated to a temperature equal to or greater than the melting temperature of the material to be removed. In such instance, as the scribing tip **74** is moved relative to the layer currently being fabricated **12**, the scribing tip **74** has a tendency of melting, plowing, moving and/or displacing material and thereby forming a desired channel, trough, trench or groove **22R** in the layer currently being fabricated **12** which is simultaneously filled with the high viscosity material **M**.

[0167] As scribing tip **74** is carving, plowing, pushing, melting and/or otherwise displacing the recently deposited and partially solidified (e.g., build) material so as to form a desired channel, trough, trench or groove **22R** in the layer currently being fabricated **12**, some of the partially solidified (build) material may be sufficiently solidified and thus has a tendency to break, fragment or otherwise become separated or dislodged from the layer currently being fabricated **12**. Although this may occur, such broken, fragmented or otherwise separated and/or dislodged solidified material will normally become partially or fully encased, encapsulated and/or enclosed within the high viscosity (filling) material **M** which is being simultaneously deposited, as described below in further detail. Such broken, fragmented or otherwise dislodged solidified material, which becomes encased, encapsulated and/or enclosed within the high viscosity material **M**, will be normally be easily removed, along with the high viscosity material **M**, during the subsequent separation process in order to obtain the final model **10** to be fabricated.

[0168] It is to be appreciated that the dispensing/shaping orifice **80** may have a variety of alternative shapes or forms, such as an oval, a rectangular, a square, etc., for example, to

assist with shaping and controlling the flow and the distribution high viscosity material M, as such material flows out of the dispensing/shaping orifice 80 and into the desired channel, trough, trench or groove 22R in the layer currently being fabricated 12. The dispensing/shaping orifice 80 has width and length dimensions which are sufficient to completely fill the channel, trough, trench or groove 22R which is formed in the layer currently being fabricated 12 as the scribing tip 74 simultaneously moves relative to the layer currently being fabricated 12. That is, the overall dimensions of the dispensing/shaping orifice 80 are larger than that of the scribing tip 74 to ensure complete simultaneous filling of the channel, trough, trench or groove 22R.

[0169] If desired, the perimeter edge, formed at the interface between the leading end surface 82 of the high viscosity rapid deposition head 68 and the vertical sidewall thereof, may be rounded, curved or beveled to assist with distribution of any high viscosity material M which is extruded and/or dispensed by the dispensing/shaping orifice 80 onto the layer currently being fabricated 12. Such rounded, curved or beveled perimeter edge generally assists with shaping the high viscosity material M into a substantially uniform layer, having a desired thickness for the layer currently being fabricated 12, which is generally free of and does not contain any irregularity(ies), discontinuity(ies) or nonuniformity(ies) therein.

[0170] When both scribing of a desired channel, trough, trench or groove 22R and dispensing of the high viscosity material M is required in the layer currently being fabricated 12, the end surface 82 of the high viscosity rapid deposition head 68 is moved toward and positioned above the top surface of the layer currently being fabricated 12, by a distance that is at least equal to or preferably slightly greater than, e.g., by about 0.0005 inches or so for example, the intended final thickness of the layer of the high viscosity material M to be deposited. For a typical application, the high viscosity rapid deposition head 68 will be positioned such that the end surface 82, accommodating the dispensing/shaping orifice 80, is spaced six thousandths of an inch (0.006 inch) or less from the top surface of the layer currently being fabricated 12 during contact coating, and more preferably the dispensing/shaping orifice 80 is spaced to within about three to four thousandths of an inch (0.003 to 0.004 inch) from the top surface of the layer currently being fabricated 12 during contact coating.

[0171] As will be discussed further below, the combined scribing/filling device 64 may be secured in a fixed position on the tool platform 40T, relative to the position(s) of one or more other material deposition devices, such as one or more drop-by-drop devices or one or more other high deposition rate devices. It will be noted, however, that the required or desired spacing, between the end surface 82 of the high viscosity rapid deposition head 68 and the layer currently being fabricated 12, will typically be less than the required or customary spacing between a drop-by-drop deposition device or for a lower viscosity rapid deposition device. Therefore, it may be preferable or necessary, as indicated above, to mount the combined scribing/filling device 64 on the tool platform 40T so as that the combined scribing/filling device 64 is axially movable, along the Z-axis, with respect to the other material deposition device(s), so as to space the combined scribing/filling device 64 at a desired distance from the layer currently being fabricated 12, immediately prior to the combined scribing/filling device 64 commencing its combine scribing/filling procedure. It is to be appreciated that a servomotor or some other indexable or stepped motor may be

utilized for moving the combined scribing/filling device 64, along the Z-axis, relative to the tool platform 40T.

[0172] While the scribing tip 74 has generally been described and depicted as being cylindrically shaped, it is to be appreciated that the scribing tip 74 can have a variety of different sizes and/or shapes as generally shown in FIG. 8. For example, the scribing tip 74 shown on the far left of that drawing is utilized for formation of a generally rectangular channel, trough, trench or groove 22R. The scribing tip 74, shown second from the left in that drawing, has a smaller diameter and is utilized for formation of generally a smaller sized rectangular channel, trough, trench or groove 22R. The scribing tip 74 shown on the far right of that drawing is utilized for formation of a generally tapered channel, trough, trench or groove 22R. The scribing tip 74, shown second from the right in that drawing, has a steeper taper and is utilized for formation of a channel, trough, trench or groove 22R which has greater degree of taper. It is to be appreciated that the scribing tip 74 may have a variety of different lengths as well as a variety of other shapes and/or sizes, depending upon the particular application at hand. In particular, if a deeper channel, trough, trench or groove 22R is desired, the length of the scribing tip 74 can be significantly increase.

[0173] With reference to FIG. 9A-9E, the method and operation of the combined scribing/filling device 64, for both scribing the desired channel, trough, trench or groove 22R into the layer currently being fabricated 12 as well as simultaneously filling the formed channel, trough, trench or groove 22R with the high viscosity (filling) material M, will now be described. Referring first to FIG. 9A, the leading surface 94 of the scribing tip 74 is diagrammatically shown located closely adjacent to, but slightly spaced from the top surface of the layer currently being fabricated 12. FIG. 9B, in turn, shows the scribing tip 74 immediately after the scribing tip 74 has penetrated and was forced vertically into the layer currently being fabricated 12, due to relative movement of the scribing tip 74 and the layer currently being fabricated 12, so that the leading surface 94 of the scribing tool 66 substantially abuts against and extends parallel to and coincident with the top surface of the previous layer 96. As diagrammatically shown in this Figure, the scribing tip 74 displaces the (e.g., build) material located directly underneath the bottom, leading surface 94 of the scribing tip 74 and such displaced material generally causes previously deposited material to move and be displaced away from the scribing tip 74 and flow toward and/or accumulate on the vertically top most surface of the layer currently being fabricated 12, typically in the vicinity and around the entire perimeter of the scribing tip 74, as generally diagrammatically shown in FIG. 9B.

[0174] As soon as the scribing tip 74 penetrates into the layer currently being fabricated 12—or possibly slightly before the scribing tip 74 is forced into the layer currently being fabricated 12—the flow of the high viscosity material M from the temporary storage space 78 to the dispensing/shaping orifice 80 commences, and this is diagrammatically shown in FIG. 9C. That is, the pump or pressure source P supplies the high viscosity material M from the source S to the temporary storage space 78 which, in turn, induces the flow of the high viscosity material M out through the dispensing/shaping orifice 80 of the combined scribing/filling device 64 and onto the top surface of the layer currently being fabricated 12. Lateral movement of the scribing tip 74 commences, as shown by the arrow in FIG. 9D, as soon as the leading surface 94 of the scribing tool 66 abuts against the top surface of the

previous layer 96 so as to prevent an excessive amount of the high viscosity material M from accumulating on the layer currently being fabricated 12.

[0175] As the scribing tip 74 moves relative to the layer currently being fabricated 12, the scribing tip 74 commences carving, plowing, pushing, melting, displacement and/or formation of a desired channel, trough, trench or groove 22R therein. As shown in FIG. 9D, the flow of the high viscosity material M out through the dispensing/shaping orifice 80 of the high viscosity rapid deposition head 68 is controlled, by the system controller 54 (as generally shown in FIG. 4A), to flow at a sufficient flow rate which completely fills the formed channel, trough, trench or groove 22R. As the dispensed high viscosity material M is at a somewhat elevated temperature and the dispensed high viscosity material M is somewhat molten and flowable, this assist with complete and uniform filling of the formed channel, trough, trench or groove 22R, before the high viscosity material M cools sufficiently. Preferably, the dispensing/shaping orifice 80 dispenses a sufficient amount of the high viscosity material M so as to not only completely fill the formed channel, trough, trench or groove 22R, but also provide a small excess amount of the high viscosity material M to ensure that the filled channel, trough, trench or groove 22R, following planing thereof, will result in a perfectly flat and level surface for the layer currently being fabricated 12, without any irregularity(ies), discontinuity(ies) and/or nonuniformity(ies) formed therein.

[0176] Once the scribing tool 66 has completed formation of the desired channel, trough, trench or groove 22R in the layer currently being fabricated 12, further lateral movement of the scribing tool 66 with respect to the layer currently being fabricated 12 discontinues. In addition, the flow of the high viscosity material M to the dispensing/shaping orifice 80 discontinues and the supply of power to the heating element E also discontinues. The scribing tip 74 is then retracted vertically from the formed and filled channel, trough, trench or groove 22R, due to relative movement between the scribing tip 74 and the layer currently being fabricated 12 as shown in FIG. 9E. Due to surface tensions of the materials as well as the temperature and the relative flowability of the deposited high viscosity material M, the high viscosity material M, which is located adjacent the void created by retracting the scribing tip 74 from the channel, trough, trench or groove 22R, will automatically flow into and completely filled the void. This ensures that the entire channel, trough, trench or groove 22R is consistently and completely filled with the high viscosity (filling) material M.

[0177] It is to be appreciated that the flow of the high viscosity material M can commenced prior to penetration of the scribing tip 74 into the top surface of the layer currently being manufactured 12 and/or the flow of the high viscosity material M, to the dispensing/shaping orifice 80, may be discontinued only after the scribing tip 74 is removed from the formed channel, trough, trench or groove 22R, following formation thereof, without the departing from the spirit and scope of the present invention.

[0178] While the above description generally relates to a tool platform 40T which supports a combined scribing/filling device 64, it is to be appreciated that two or more combined scribing/filling devices 64 may be supported by the same tool platform 40T. In such instance, each one of the combined scribing/filling devices 64 typically supports a uniquely shaped scribing tip 74 so as to facilitate scribing of two or more different shaped channel(s), trough(s), trench(es) or

groove(s) 22R in the layer currently being fabricated 12 by selectively choosing, via the system controller 54, the appropriately combined scribing/filling device 64. In addition, it is to be appreciated that each scribing tool 66 can be readily replaced and/or interchanged with another scribing tool 66 having a desired shape to provide increased versatility for the present invention.

[0179] When operating in the appropriate range of conditions, including spacing of the end surface 82 of the high viscosity rapid deposition head 68 with respect to the layer currently being fabricated 12, the temperature and the viscosity of the high viscosity material M, the flow rate and pressure of the high viscosity material M through the dispensing/shaping orifice 80, and the rate and the travel direction of the combined scribing/filling device 64 relative to the layer currently being fabricated 12, the extruded high viscosity material M will form a layer of high viscosity material M which is located between the end surface 82 of the high viscosity rapid deposition head 68 and the preceding layer.

[0180] A conventional system controller 54 controls operations of the fabrication system including, for example, the positioning of the table T and the tool platform 40T, all operations of the combined scribing/filling device 64, the flow of the high viscosity material M to the combined scribing/filling device 64 (e.g., control operation of the valve(s) V and the pump(s) P), operation of the heating element E, lateral movement of the tool platform 40T relative to the table T to facilitate scribing of the desired channel, trough, trench or groove within the layer currently being fabricated, vertical positioning of the tool platform 40T relative to the table T, etc. As such features and control functions of the system controller 54 are conventional and well known in the art, a further detail description concerning the same is not provide.

[0181] Since certain changes may be made in the above described process and apparatus without departing from the spirit and scope of the invention herein involved, it is intended that all of the subject matter of the above description or shown in the accompanying drawings shall be interpreted merely as examples illustrating the inventive concept herein and shall not be construed as limiting the present invention.

Wherefore, we claim:

1. A combined scribing/filling device for scribing a desired channel, trough, trench or groove in a layer currently being fabricated and simultaneously filling the scribed channel, trough, trench or groove with a desired filling material, the combined scribing/filling device comprising:

a scribing tool having a scribing tip which facilitates scribing of the desired channel, trough, trench or groove in the layer currently being fabricated; and  
a dispensing/shaping orifice for filling the scribed channel, trough, trench or groove with the filling material;  
wherein the scribing tip being located coincident with respect to the dispensing/shaping orifice to facilitate simultaneously scribing and filling of the channel, trough, trench or groove.

2. The combined scribing/filling device according to claim 1, wherein at least the scribing tip is vertically movable along a Z-axis, with respect to the layer currently being fabricated, to facilitate penetration of the scribing tip into the layer currently being fabricated and facilitate withdrawal of the scribing tip from the layer currently being fabricated.

3. The combined scribing/filling device according to claim 2, wherein the support table is movable toward the scribing tip to facilitate penetration of the scribing tip into the layer cur-

rently being fabricated, and the support table is movable away from the scribing tip to facilitate retraction of the scribing tip from the layer currently being fabricated.

4. The combined scribing/filling device according to claim 2, wherein the combined scribing/filling device is supported by a tool platform, and the combined scribing/filling device is movable, along a Z-axis, relative to the tool platform to facilitate penetration of the scribing tip into the layer currently being fabricated, and facilitate withdrawal of the scribing tip from the layer currently being fabricated.

5. The combined scribing/filling device according to claim 1, wherein the dispensing/shaping orifice is formed in a leading end surface of a high viscosity rapid deposition head, the high viscosity rapid deposition head has an internal cavity, and the scribing tool is accommodated within the internal cavity so that the scribing tip protrudes out through the dispensing/shaping orifice.

6. The combined scribing/filling device according to claim 5, wherein the high viscosity rapid deposition head comprises an elongate deposition body which is manufactured from a conductive material, an exterior surface of the high viscosity rapid deposition head supports a heating element which maintains the filling material at a desired flow temperature to assist with both commencing flow and interrupting flow of the filling material out of the dispensing/shaping orifice.

7. The combined scribing/filling device according to claim 5, wherein the internal cavity comprises a temporary storage space and a supply passageway, and the supply passageway communicates with the dispensing/shaping orifice formed in the leading end surface of the high viscosity rapid deposition head.

8. The combined scribing/filling device according to claim 7, wherein the scribing tool comprises a main body which is shaped and sized to be received within the temporary storage space, the scribing tip is supported adjacent a leading end of the scribing tool, while an intermediate body section and a transition section interconnect the main body with the scribing tip, and the intermediate body section and the transition section are accommodated within the supply passageway.

9. The combined scribing/filling device according to claim 8, wherein at least one section or area is provided, between the intermediate body section and the supply passageway, to define a flow path which facilitates flow of the filling material from the temporary storage space to the dispensing/shaping orifice for dispensing by the combined scribing/filling device.

10. The combined scribing/filling device according to claim 9, wherein as the filling material flows from the temporary storage space along the supply passageway, the filling material flows between an exterior surface of the scribing tool and an inwardly facing surface of the supply passageway until the filling material reaches the transition section where the filling material fills the supply passageway, except for area occupied by the transition section and the scribing tip.

11. The combined scribing/filling device according to claim 1, wherein the scribing tool comprises an elongate element which defines a longitudinal axis which extends centrally from a trailing end thereof to scribing tip, and the high viscosity rapid deposition head defines a longitudinal axis which extends centrally from a trailing end thereof to the dispensing/shaping orifice, and the longitudinal axis of the scribing tool and the longitudinal axis of the high viscosity rapid deposition head are coincident with one another.

12. The combined scribing/filling device according to claim 1, wherein one of a pump and a pressure source facili-

tates the supply of the filling material to a temporary storage space of the high viscosity rapid deposition head, and a flow valve is located along a supply conduit for controlling the flow of the filling material from a source to the temporary storage space.

13. The combined scribing/filling device according to claim 1, wherein, during scribing and dispensing of the filling material, the leading end surface of the high viscosity rapid deposition head, which defines the dispensing/shaping orifice, is spaced about six thousandths of an inch (0.006 inch) or less from a top surface of the layer currently being fabricated.

14. The combined scribing/filling device according to claim 1, wherein the dispensing/shaping orifice has width and length dimensions which are sufficient to completely fill the channel, trough, trench or groove which is formed in the layer currently being fabricated as the scribing tip is moved relative to the layer currently being fabricated so as to ensure complete filling of the channel, trough, trench or groove.

15. The combined scribing/filling device according to claim 1, wherein a perimeter edge, at the interface between the leading end surface of the high viscosity rapid deposition head and a vertical sidewall thereof, is one of rounded, curved or beveled to assist with distribution of the filling material which is dispensed by the dispensing/shaping orifice onto the layer currently being fabricated to assist with dispensing of a substantially uniform layer.

16. The combined scribing/filling device according to claim 1, wherein the combined scribing/filling device is supported by a tool platform in a spaced relationship with respect to at least one other material deposition device, and the tool platform is movable relative to a build table in order to facilitate fabrication of a desired the composite model, and the combined scribing/filling device is axially movable, along a Z-axis, with respect to the at least one other material deposition device, to facilitate positioning of the combined scribing/filling device at a desired distance from the layer currently being fabricated.

17. A method of fabricating a three dimensional model from a composite model formed by a plurality of layers with the composite model comprising at least one separation material encasing and enclosing a build material, the method comprising the steps of:

- (1) depositing a build layer of the build material onto a preceding layer;
  - (2) removing a selected area of the build material from the deposited build layer and simultaneously depositing the separation material in any removed selected area of the build material; and
  - (3) reducing the build layer to a desired final thickness for supporting a next subsequent build layer; and
- (B) repeatedly repeating steps (1) through (3) for each build layer until the composite model is completed.

18. The method of fabricating the three dimensional model according to claim 17, further comprising at least one initial step of:

- (A) depositing at least one layer of a foundation material for forming a foundation layer to support a bottom most first build layer of the composite model, and
- (B) reducing the foundation layer to a desired final thickness for supporting the bottom most first build layer of the composite model.

19. The method of fabricating the three dimensional model according to claim 17, following completion of the composite

model, further comprising removing extraneous build material from the composite model thereby leaving an exterior surface of the final model.

**20.** The method of fabricating the three dimensional model according to claim **17**, following completion of the composite model, further comprising removing both extraneous build material from the composite model and the separation material thereby leaving an exterior surface of the final model.

\* \* \* \* \*